

Ginseng Seed Shaker



Bill of Materials

Material	Quantity
1-1/2 x 1-1/2 x 45" Angle	2
1-1/2 x 1-1/2 x 60" Angle	2
1-1/2 x 1-1/2 x 30" Angle	1
2 x 2 x 30" Angle	1
1 x 1 x 30" Square	2
1 x 1 x 20" Angle	2
1 x 1 x 9" Angle	2
1/8 x 4 x 4 Plate	4
3/8 x 5 x 5 Plate	2
1/8 x 5 x 10 Plate	1
7 x 14.5' 14 Gauge Sheet Metal	1
35" x 1 Dia. Steel Shaft	1
6" x 1-1/2 Dia. Steel Shaft	1
2-1/4 x 1-1/4 x 1/8 Pipe	8
1 x 30 x 1/8 Flat	4
15" x 1-1/2 Pipe	2
15" x 1 Pipe	2
12 x 12 24 Gauge Sheet Metal	1
2 x 4 Springs	4
30" x 60" Screen	1
1/2 Horse Motor	1
30" Belt	1
8" Dia. Pulley	1
1-1/2" Dia. Pulley	1
1" Inside Dia. Bearing	2
3/8 x 2" Bolts	12

A ginseng seed shaker shifts sand from the ginseng seeds. This shaker sifts the mixed sand from seeds by vibrating down a 5 ft. screen in a box. Vibration is caused by a solid shaft welded on the side of the main shaft. This off-set feature causes an uneven motion. Four springs in the corners creates a jumping motion. The shaft is powered by a 1/2 horse electric motor which funnels the seeds into a container.

1.) Cut the metal into the proper lengths (specifications on Bill of Material). The base table is fabricated first. The back legs are 30" high and made out of 1"x 3/16" square tubing. The front legs are made from 16" of 1-1/2" pipe and 14" of 1" pipe. Slipping the smaller pipe into the larger pipe makes the legs adjustable. Drill 4 holes evenly into both pipes to make numerous angles possible.

2.) The main box or table is made out of 1-1/2"x 1-1/2"x 3/16" angle iron. Cut the back piece of the box to a width of 30". The sides of the box are 60" long. On the front of the box, attach a 1"x 3/16" flat piece of steel. With the box this size the sand will be sifted from the seeds. Make braces from the angle iron. Cut the two side braces 45" in length. Cut the back brace from 2" angle iron to support the motor.

3.) To make the frame of the box, cut angle iron at 45° angles and fit together. Square the pieces and arc weld together with a basic weave bead.

4.) Cut out and weld a 4"x 4" plate on top of each leg, making sure each plate is centered on the leg. Weld a 2" back brace in

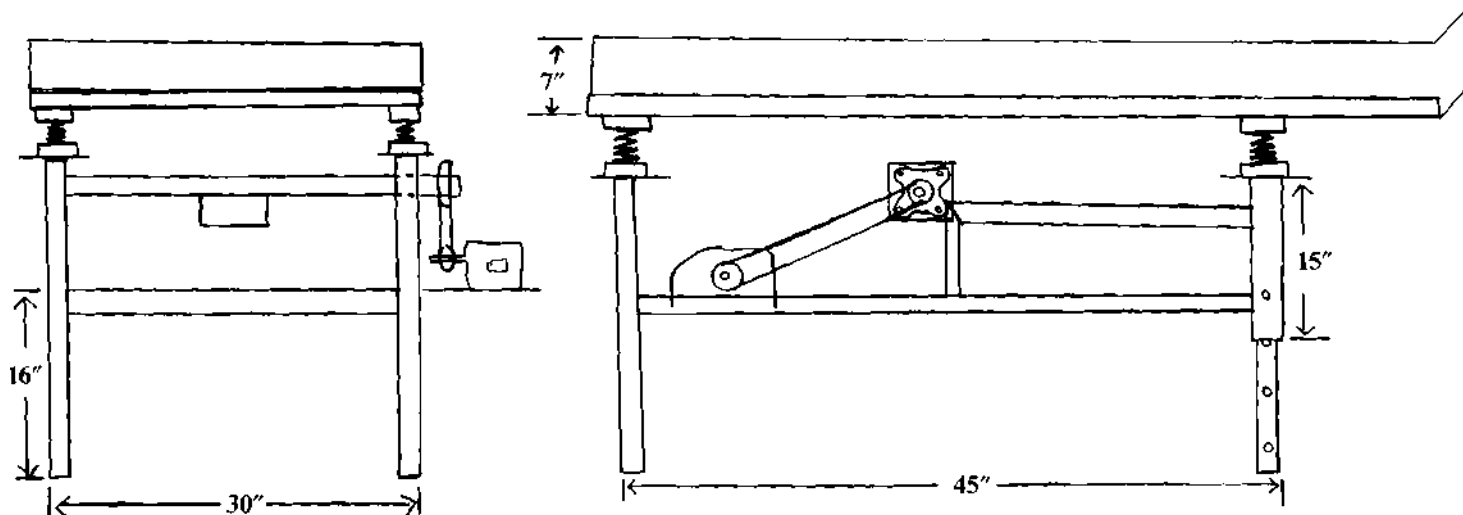

between the back legs with the top edge of the angle iron 16" from the bottom of the leg. Weld side braces on the back leg assemblies, 16" from the bottom of the legs. Weld them on 1-1/2" pipe to allow the legs to be adjustable. Make sure the legs are straight and equal in length so the table sits level.

5.) Frames for the bearings and the shaft are made using 1-1/2" angle iron, cut into two 9" pieces and two 20" pieces. Cut one end of each piece at 45° and weld together. On the other end cut out grooves for a better fit and to give stronger welds. On one end, cut out a round groove to fit the front leg, which is made of round pipe. On the bottom of the 9" piece, a square groove is cut to fit the angle iron.

6.) The shaft consists of one 35" piece of 1" solid steel. A 6" piece of solid 2" steel welded on the side of the 1" shaft at the center will create the vibration.

Shaft assembly: After completing the bearing frames two 5"x 5"x 3/8" pieces of flat steel are needed (one for each side). These pieces are welded on the corners where the 45° angles were cut. These are plates which the bearings will be bolted to. Line up the bearing holes with the plate. Mark each hole and drill it out with a 3/8" drill bit. Bolt down the bearing. Mark the main bearing hole on the plate making it a little bigger than the original 1" bearing hole. Cut this hole out with a oxy-acetylene torch. File any rough edges. Weld one plate on each bearing frame, carefully keep the plate straight so the bearing and the shaft do not become twisted.

7.) After completing the bearing and shaft assembly the main table is fabricated. Under the table on top of the legs a 2"x 4" spring is placed. The springs sit in a 2-1/4" pipe, 1-1/4" in

length. Use eight of these pieces, (two for each corner, one mounted on the plate on the leg, one welded to the bottom of the table).

To the table weld three 29-1/2" cross pieces, cut from 1"x 3/16" flat steel similar to the front piece. These cross pieces support the screen in the table when the sand and the seed are poured in. The screen is 30"x 60" and is laid inside the table. On the sides against the angle iron 14 gauge sheet metal stands 7" high. Bend this sheet metal to fit inside the table with 12" hanging over the front. Bend with a slight angle so it will funnel the seeds into a container. Weld the sheet metal to the angle iron sides. Inside the sheet metal place one inch strips of wood around the table. Drill 3/8" holes in the wood strips, bolt down to keep the screen tight.

8.) Mount a 1/8"x 5"x 10" piece of flat steel onto the back right leg with two 5/16" bolts. Cut slotted holes in the plate to mount the motor. With slots in the plate, the motor can be adjusted to tighten the belts. Place a 1/2 horse electric motor on the plate and mount pulleys on the shaft of the seed shaker and motor shaft. Place a 1-1/2" pulley on the motor and a 8" pulley on the shaker. Place a 30" belt on the motor and tighten down the bracket bolts. (These dimensions may vary according to the size and shape of the motor.)

9.) By now the shaker should be in working order. For safety, place a shield around the motor and the shafts, Use 24 gauge sheet metal and spot weld. This shield will also help keep sand from building up around the motor.

To give the seed shaker a neat appearance it can be painted.