EEL 6503
Spread Spectrum & CDMA
Project: IS-95, System Analysis and
Simulation using SIMULINK ®

Instructor: Dr. Wong
Student: Jose Arteaga

FALL 2000

TABLE OF CONTENTS

	Page
1 ABSTRACT.....	3
2 INTRODUCTION.....	2
3 MOBILE RADIO CHANNEL - BASICS.....	4
4 FUNDAMENTALS OF THE IS-95 SYSTEM.....	6
5 CDMA BLOCKSET FOR SIMULINK AND SIMULATIONS.....	13
6 CONCLUSIONS AND RECOMMENDATIONS.....	17
7 REFERENCES.....	18

1. ABSTRACT

Mobility is a great issue these times as anyone can see, cell phones, pagers, Wireless LANs (Local Area Networks) among others are a clear example of this.

Spread Spectrum techniques are already implemented in some of the services available now.

Two clear examples of these are the wireless local area networks standard IEEE802.11b and the Mobile Telephony Market (better known as PSC: Personal Communications Services).

The Standard that regulates this service is the IS-95 (Intermediate Standard- 95) but the actual scope it's to increase the actual QOS (Quality of Service) in order to provide more options to the users. There are some committees that are working on this subject (CDMA2000, Third Generation of Cellular or 3G among others)

The scope of this project is to understand the actual standard for Personal Communications Services (PCS) better known as IS-95. Try to explain some of the individual components of this standard as a system level description and finally use an available tool for simulation, like the CDMA reference blockset for Simulink® in order to simplify the analysis of this kind of system.

2. INTRODUCTION

The biggest problem in wireless communications is the multipath channel (or wireless channel) couldn't be this in outdoor or indoor environments. The communications designer has to deal with a really hostile environment in wireless communications, been the two major problems: (a) the multipath characteristic of the channel, which introduces fading in the signal that is been transmitted that derives a posteriori in ISI (intersymbol interference) and, (b) the Doppler frequency shift due to the movement of the mobile user.

So, at a system level, the Network designer has to deal with a lot of issues in order to find the best available solution.

One of the most useful tools at the present time is simulation, which gives the engineer the chance to, not only figure out how that his or her design will response to a determined channel, but also to change the conditions of the environment without making even one measurement of the field.

So the approach of this project has two goals, first understand and explain how does the standard IS-95 works and second learn and use a simulation tool in order to check the response of this system under different conditions.

2.1 DESCRIPTION OF A GENERAL CELLULAR SYSTEM

The cellular network consists of a large number of mobile users communicating with a base station. Neighboring cells transmit at the same frequency, adding interference to the present cell. All transmissions are either *uplink* (from a mobile host to a base station) or *downlink* (from a base station to a mobile host).

Figure 2.1 shows a typical cellular system.

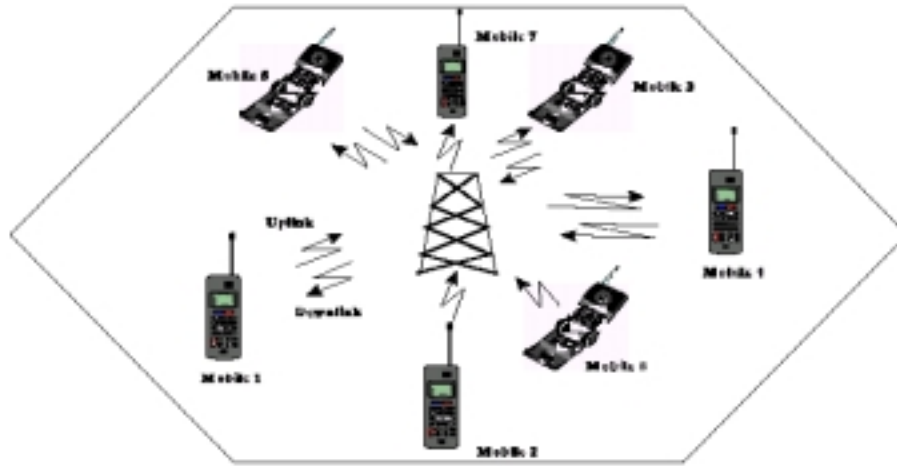

Figure 2.1

3. MOBILE RADIO CHANNEL - BASICS

The small scale variations of a mobile radio can be directly related to the impulse response of the mobile radio channel.

Due to the multipath characteristics of the radio channel in an urban area it can be shown [1] that the channel may be modeled as a linear filter with a time varying impulse response.

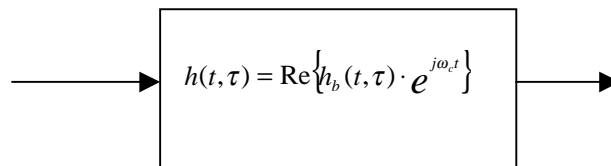

Figure 3.1

As we can see in Figure 1, the channel representation is a Time varying linear system, where we can use the base band representation (h_b) [2] instead of the band pass one, for simplicity. The input to this system is the transmitted signal and the output is the signal distorted by the channel.

This impulse response can be measured using different techniques: Direct RF pulse system, spread spectrum sliding correlator channel sounding and frequency domain channel sounding [1].

3.1 FADING EFFECTS DUE TO MULTIPATH TIME DELAY SPREAD

Time dispersion due to multi path causes the transmitted signal to undergo either flat or frequency selective fading.

Flat Fading: If the mobile radio channel has a constant gain and linear phase response over a bandwidth that is greater than the bandwidth of the transmitted signal the received signal will undergo flat fading. In flat fading the multipath structure of the channel is such that the spectral characteristic of the transmitted signal is preserved at the receiver. However the strength of the received signal changes with time, due to fluctuations in the gain of the channel caused by multipath. It can be shown [1] that if the channel gain changes over time a change of amplitude occurs on the received signal. Over time the received signal $r(t)$ varies in gain but the spectrum of the transmission is preserved.

Frequency Selective Fading: If the mobile radio channel has a constant gain and linear phase response over a bandwidth that is smaller than the bandwidth of the transmitted signal, then the channel creates frequency selective fading on the received signal. Under such conditions the channel impulse response has a multipath delay spread.

When this occurs, the received signal includes multiple versions of the transmitted waveform which are attenuated and delayed in time, thus the received signal is distorted. Frequency selective fading is due to time dispersion of the transmitted symbols within the channel. Thus the channel induces *intersymbol interference* (ISI). In the frequency domain point of view, certain frequency components in the received signal spectrum have greater gain than others.

There are a lot of techniques used in order to compensate the above mentioned intersymbol interference (ISI) created by multipath within time dispersive channels. As we just mention, if the modulation bandwidth exceeds the coherence bandwidth of the radio channel, ISI occurs and modulation pulses are spread on time. An *equalizer* within the receiver (not used in IS-95) could be a possible solution in order to mitigate the effects introduced by the channel due to the amplitude and delay characteristics. There are some other techniques like the *rake receiver* (part of the IS-95) to perform the same task [1][3]. Figure 3.2 shows the simulation of a typical Rayleigh fading channel in a multipath environment implemented in Matlab®.

Note the “nulls” which are the points where the amplitude decreases like 70 dB.

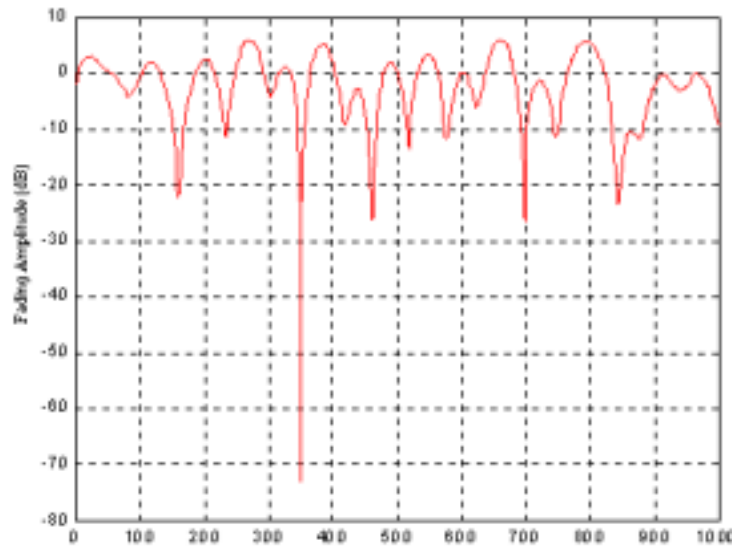

Figure 3.2

Since the hostile characteristics of the Wireless channel, from the Network point of view, are pretty obvious at this moment, the need for simulation while designing a system is obvious too.

As we mentioned before, the simulation tool selected for this project is the Matlab® based graphical programming tool SIMULINK®. Two very powerful tools that can be used in this environment are the Communications and CDMA toolboxes.

Based on the name of these toolboxes, it's obvious that they may match our needs for simulation.

4. FUNDAMENTALS OF THE CDMA DIGITAL CELLULAR STANDARD (IS-95)

As it was mentioned, a number of different CDMA air interfaces are being deployed and proposed for mobile and portable wireless systems, WLL (wireless local loop), satellite systems and Wireless LANs. But is known [2] that by far the most widely deployed CDMA technology is the IS-95 based cellular and PCS CDMA technology which is used in North and South America, Asia and elsewhere. This technology which includes the IS-95A standard for 800 MHz cellular systems and the JTD-008 standard for 1900 MHz PCS systems [2] will be collectively named as IS-95. If the reader is familiar with the OSI 7 layers model for networks, this description will be primarily concerned with the Layer 1 or physical layer of CDMA systems.

The detailed description of these systems can be found in the two standards available: TIA IS-95 and ANSI J-STD-008, which provide in-depth information.

The PCS frequency allocation are shown in Table 4.1

Band	Channel Numbers	Mobile user TX Freq. [MHz]	Base Station TX Freq. [MHz]
A	0-299	1850-1865	1930-1945
D	300-399	1865-1870	1945-1950
B	400-699	1870-1885	1950-1965
E	700-799	1885-1890	1965-1970
F	800-899	1890-1895	1970-1975
C	900-1199	1895-1910	1975-1990

Table 4.1

PCS do not use the same the same spectrum as the AMPS cellular service [1]. It uses a total of 120 MHz in the 1850-1990 MHz band, allowing up to six providers of the service (in addition to the cellular providers).

Each CDMA carrier requires a bandwidth of 1.25 MHz or 25 channels, each one of 50 KHz. Since operation near the edges of the PCS band is prohibited, there are a number of "preferred" channels [2] for coordination between the different providers.

4.1 HOW IS-95 CDMA PCS SYTEM WORK

Two-way cellular communications relies on many channels to ensure call connection and delivery. Control Channels include paging channels that are use to notify mobile user of

incoming calls and Access Channels that let the user initiate outgoing calls. Traffic Channels are used to support user voice calls and messages.

In a CDMA network, all base stations use the same frequency channel or carrier. Spreading codes are used to separate the signals. Each base station is synchronized to a CDMA system time, which is obtained from a precise time reference supplied by GPS satellites [2]. Every base station transmits a pilot signal on the downlink using the same pseudo-noise (PN) sequence, but each pilot is delayed on time with respect to the others allowing the user to differentiate the signals. The pilot PN sequence is 32768 chips long [2] at a chip rate R_c of 1.2288 [Mchip/sec], so that each pilot PN sequence repeats every 26.67 msec. Each base station pilot is transmitted in a way that its PN sequence starts with an offset that is an integer multiple of 64 chips or 52.08 μ secs, from other sequences.

Since there are 32768 chips in the pilot PN sequence, and PN offsets are integer multiples of 64 chips, there are 512 pilot offsets.

The IS-95 CDMA subscriber phone searches for pilot signals that are strong enough to detect. Each user unit can combine at least 3 independent forward traffic signals using a Rake receiver [1] to improve reception.

A unique feature of the CDMA systems is that adjacent base stations can transmit the same signals to a mobile user enhancing downlink link quality. This is called soft hand off [2]. This hand off can increase a lot link performance, but on the other hand, because of the traffic channel, it can reduce forward link capacity [2].

Each subscriber divides the pilot signals it receives into sets. The active set is comprised of the pilot channels made available to the user by the Mobile Switching Center (MSC). This active set can contain up to six pilot PN offsets (6 sectors transmitting on the same carrier frequency). The pilot signal with enough strength to be demodulated that are NOT on the active set, make up the "candidate" set. The neighbor set is a list of "nearby" pilots that are likely candidates for handoff and are transmitted periodically by the base stations. The "remaining" set is comprised of any pilot channels not included in any of the previous sets.

This situation is geographically depicted in figure 4.1. The IS-95 user monitors a subset of the 512 potential pilot channels reporting the signal quality and Chip-Energy-to-Interference Ratio (E_c/I_0) to the base station and MSC.

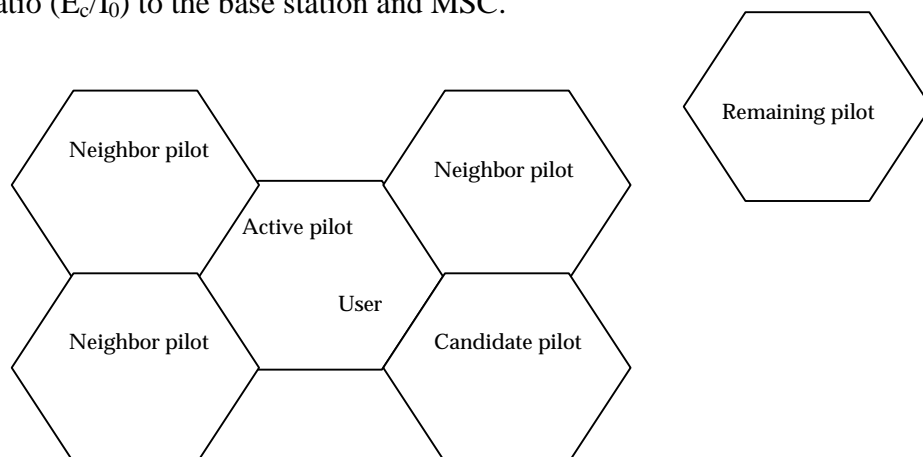

Figure 4.1

The mobile station continually searches for pilot signals on the current frequency assignment. When it detects a pilot with enough power (greater than a threshold T_ADD) that is not active, the mobile sends a Pilot Strength Measurement Message (PSMM) to the base station. The Base Transceiver Stations (BTSs) associated with the previous active set may then assign a new forward traffic channel to the subscriber unit to add the new found pilot to its active set.

Mobile user's unit also can request the MSC to drop certain pilots from the active set. If a pilot in the active set drops below the threshold (T_DROPP) and the handoff drop timer expires (T_TDROPP), the subscriber unit sends a PSMM. The base station then determines if a handoff is required and return a handoff message if the case. If the handoff is needed the mobile station then moves the pilot from the active set to the neighbor set.

Scanning across the entire code domain in a continuous way would introduce intolerable delays, so the user unit must scan pilots selectively. It searches around pilot offsets in the active, candidate and remaining lists. A search window, typically from 4 to 130 chips is specified for each pilot offset. Pilots in the active set are checked most often, candidate and neighbors pilots are checked less often and remaining pilots are checked infrequently. Active pilots have small search windows (around 40 chips) while candidates and neighbors have large search windows (around 120 chips).

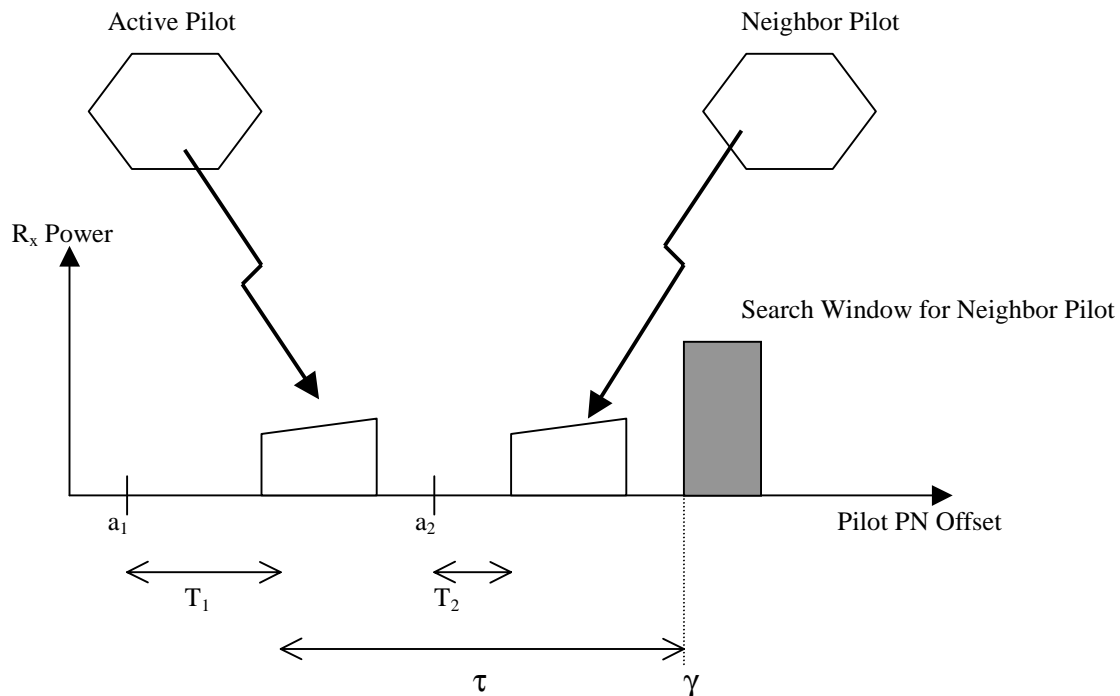

Figure 4.2

In figure 4.2 a_1 is the known pilot offset of the active pilot and T_1 is the propagation delay. The pilot offset of the neighboring pilot a_2 offers a smaller propagation delay, T_2 to

the same subscriber. The time delay τ , which determines the relative pilot offset between two pilots represents the pilot PN offset between the two downlink transmissions ($a_2 - a_1$). The mobile will set a search window (figure 4.2) and look the neighboring pilot around the time $\gamma = a_1 + T_1 + \tau$. If the propagation delay are too different between base stations, the pilot signal may fall outside the of the search window designed for the original pilot. If this happens, the mobile will not be able to find the neighboring base station and the call may be dropped.

The mobile's search window size must be large enough to contain the apparent "wandering" of each neighbor pilot due to propagation delay and at the same time this window must be set as small as possible so that the mobile can search through all the neighbors in a fast way. It's pretty obvious that the selection of the size of this window is critical to maximizing the performance of a CDMA system [2].

Each of the downlink signals generated by a single base station sector is orthogonal, so they don't interfere with each other.

In IS-95 there is a maximum of 64 downlink channels including the pilot channel and a sync channel, paging channels and traffic channels. But with realistic considerations (Multiple access interference MAI among others) it can be show that the number of users per carrier (sector) are from 12 to 18 [2].

4.2 FORWARD CDMA CHANNEL

The forward CDMA channel consists of a pilot channel, a sync channel up to seven paging channels and up to sixty-three forward traffic channels. In the previous section we explained the pilot channel features, the sync channel transmits at 1200 bps. The paging channel is used to send control information and paging messaging from the base station to the mobiles and it operates at 9600, 4800, 2400 or 1200 bps.

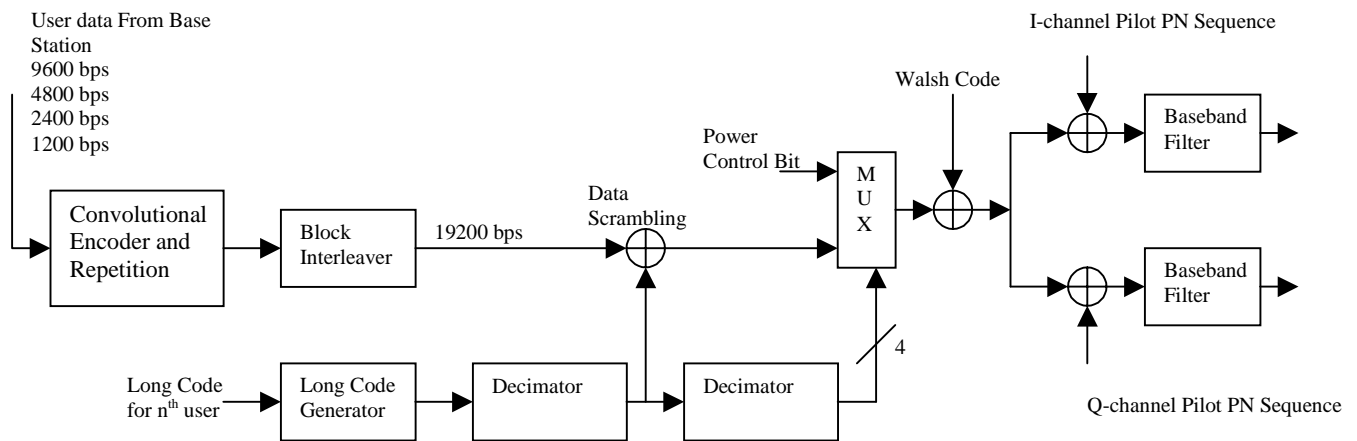

Figure 4.3

Figure 4.3 shows the forward traffic modulation process. Data on the forward traffic channel is grouped into 20 msec frames [1]. User data is convolutionally coded and then formatted and interleaved to adjust to the actual user data rate, which may vary. Then the

signal is spread with a Walsh code and a long PN sequence at a rate of 1.2288 Mcps. More details about these data rate parameters can be found in [1].

4.2.1 Convolutional Encoder and Repetition Circuit.

The speech is encoded using a half rate convolutional encoder with length 9. This encoder uses the gaps and pauses in speech and reduces its output from 9600 bps to 1200 bps during silent periods. In order to keep constant baseband symbol rate of 19.2 Kbps whenever the user rate is less than 9600 bps, each symbol from the convolution encoder is repeated before interleaving [1].

4.2.2 Block Interleaver.

After convolution coding and repetition symbols are sent to a 20msecs block interleaver, which is a 24 by 16 array. Details about the interleaver can be found in [1].

4.2.3 Long PN Sequence

In the forward channel, Direct sequence (DS) is used for data scrambling. The long PN sequence is uniquely assigned to each user and is has a period of $2^{42}-1$ chips. The long code is specified by the following characteristic polynomial [1].

$$p(x) = x^{42} + x^{35} + x^{33} + x^{31} + x^{27} + x^{26} + x^{25} + x^{22} + x^{21} + x^{19} + x^{18} + x^{17} + x^{16} + x^{10} + x^7 + x^6 + x^5 + x^3 + x^2 + x + 1$$

Each PN chip is generated by the modulo-2 inner product of the 42 bit mask and the 42 bit state vector of the sequence generator.

More details about this sub-system can be found in [1] & [2].

4.2.4 Data Scrambler

Data scrambler is performed after the block interleaver. The 1.2288 MHz PN sequence is applied to a decimator, which keeps only the first chip out of every 64 consecutive PN chips. The symbol rate from the decimator is 19200 bps. The data scrambling is performed by modulo-2 addition of the interleaver output with the decimator output as shown in figure 4.3.

4.2.5 Power Control Subchannel

In order to minimize the bit error rate (BER) for each individual mobile user, IS-95 system force each user to provide the same power level at the base station receiver. The base station reverse traffic channel estimates and respond to the signal level for a particular mobile station. Since both the signal and the interference are time varying, power control updates are sent by the base station every 1.25 msecs. The commands that control the power are sent on the control sub-channel and it tells the mobile unit to increase or decrease it's power in 1dB steps.

The power control bit corresponds to 2 modulation symbols on the forward traffic channel. More details in [1] & [2].

4.2.6 Orthogonal Covering

This stage is performed following the data scrambling on the forward link. Each forward channel on the CDMA system is spread with a Walsh function at a chip rate of 1.2288 Mcps. Walsh functions comprise of 64 binary sequences which are orthogonal to each other. Any user that is spread using a Walsh function n is assigned a channel number n ($n= 0,1,\dots,63$).

This Walsh sequence repeats every 52.083 usecs, which is the same duration of one coded data symbol, thus each data symbol is spread by 64 Walsh chips.

The 64 by 64 Walsh function matrix is generated by the following recursive algorithm[1]

$$H_1=0; \quad H_2=\begin{bmatrix} 0 & 0 \\ 0 & 1 \end{bmatrix}; \quad H_4=\begin{bmatrix} 0 & 0 & 0 & 0 \\ 0 & 1 & 0 & 1 \\ 0 & 0 & 1 & 1 \\ 0 & 1 & 1 & 0 \end{bmatrix}; \dots \dots \dots ; H_{2N}=\begin{bmatrix} H_N & H_N \\ H_N & \bar{H}_N \end{bmatrix}$$

with N a power of two.

Each row in the 64 by 64 Walsh matrix corresponds to a channel number. This is, for the channel number n , the transmitted symbols are spread by the 64 Walsh chips in the n -th row of the Walsh matrix. Channel 0 is always assigned to the pilot channel, so this is represented by the Walsh code 0, which is the all zeros code, than the pilot channel is nothing more than a blank Walsh code consisting only of the quadrature PN spreading code. The sync channel is assigned channel number 32 and if paging channels are present, they are assigned to the lowest code channel number. All remaining channels are available for forward traffic channels.

4.2.7 Quadrature Modulation

After the orthogonal covering, data symbols are spread in quadrature (Figure 4.3). A short binary spreading sequence, with a period of $2^{15}-1$ chips, is used for easy acquisition and synchronization at each mobile receiver and is used for modulation. This short sequence is called the pilot PN sequence and is based on the following characteristic polynomials:

$$p_I = x^{15} + x^{13} + x^9 + x^8 + x^7 + x^5 + 1, \text{ for the in-phase modulation and}$$

$$p_Q = x^{15} + x^{12} + x^{11} + x^{10} + x^6 + x^5 + x^4 + x^3 + 1, \text{ for the quadrature modulation.}$$

The chip rates for the pilot PN sequences are 1.2288 Mcps. The binary I and Q outputs of the quadrature spreading are mapped into phase according the following table 4.2 [1]

I	Q	Phase
0	0	$\pi/4$
1	0	$3\pi/4$
1	1	$-3\pi/4$
0	1	$-\pi/4$

4.3 REVERSE CDMA CHANNEL

The reverse traffic channel for a single user is shown in figure 4.4. User data on the reverse channel are grouped into 20 msec frames. The data transmitted on this reverse channel is convolutionally encoded, block interleaved, modulated by a 64-ary orthogonal modulation and spread prior to transmission. All the parameters involved in this process can be found in [1].

The speech data rate in the reverse channel may be sent at 9600, 4800, 2400 or 1200 bps.

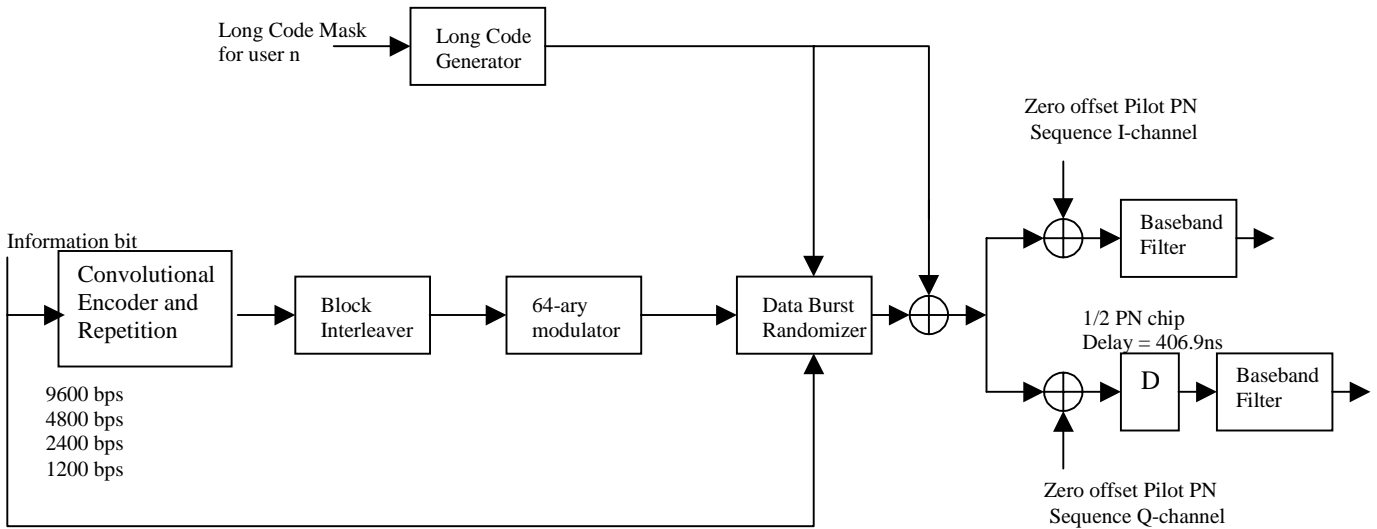

Figure 4.4

Reverse CDMA channels are made up of access channels (AC) and reverse traffic channels (RTC). Both use the same frequency and they are identified by a distinct user long code. The AC channel is used to begin to talk with the base station and to answer to paging channels messages. This channel is a random access channel with each channel user uniquely identified by their long codes. The reverse CDMA channel may contain a maximum of 32 Acs per supported paging channel.

4.3.1 Convolutional Encoder and Symbol Repetition.

The convolutional encoder used in the reverse channel is rate 1/3 and length 9. Coded bits after the convolutional encoder are repeated before interleaving when the data rate is less than 9600 bps. This is identical to the method used in the forward channel.

4.3.2 Block Interleaver.

This task is performed following convolutional encoding and repetition. The block interleaver spans 20msecs, and is an array with 32 row and 18 columns. Code symbols are written to the matrix by the columns and are read by the rows [1].

4.3.3 Orthogonal Modulation

As figure 4.4 shows, a 64-ary modulation is used for the reverse CDMA channel. One of 64 possible Walsh functions is transmitted for each group of 6 coded bits. Within a Walsh function 64 Walsh chips are transmitted at a rate of 307.2 Kcps.

It's very important to note that Walsh functions are used for different purposes on the forward and reverse channel. On the forward channel they are used for spreading to denote a particular user channel, while on the reverse channel they are used for data modulation [1] [2].

4.3.4 Variable Data Rate Transmission

Variable data rate is sent on the reverse CDMA channel. A data randomizer is used to transmit some bits while turning the transmitter off other times. When the rate is 9600 bps, all interleaver outputs are transmitted. When is 4800 bps, half of the interleaver outputs are transmitted and the mobile transceiver transmits only 50% of the time.

Data in each 20msecs are divided into 16 power control groups, each with period 1.25msecs. Some power control groups are gated-on while others are gated-off. During the gate-off process, the mobile user reduces its power by at least 20 dB with respect to the power of the most recent gated-on period or to the transmitter noise floor, whichever is greater. This is the way that the interference between users operating on the same reverse CDMA channel is reduced.

More details in [1] and [2]

4.3.5 Direct Sequence Spreading

The reverse traffic channel is spread by the long code PN sequence which operates at a rate of 1.2288 Mcps. The generation of the long code is the same as in the forward channel case [1]. Each Walsh chip is spread by 4 long code PN chips.

4.3.6 Quadrature Modulation.

Previously to transmission, reverse traffic channel is spread by I and Q channel pilot PN sequences which are the identical to those used in the Forward traffic channel. These sequences are used for synchronization purpose. The reverse link modulation is OQPSK. As its shown in figure 4.4, the data spread by the *Q* pilot PN sequence is delayed half a chip with respect to the data spread by the *I* pilot PN sequence. This is used for improved spectral shaping and synchronization [1] - [3].

5. CDMA BLOCKSET FOR SIMULINK® & SIMULATION MODELS

From the Systems Engineer perspective, a tool that let him (or her) perform simulations of a real system without writing tons of code, derives in time savings, which in these times is really an issue.

It's from this point of view the focus in this specific tool called Simulink® and more specifically in the Communications and CDMA Toolboxes.

5.1 CDMA Toolbox Main Library Structure Overview

The main library of the CDMA Reference Blockset, shown below, is organized into these sublibraries:

- IS-95A Base Station Transmitter Library
- IS-95A Mobile Station Receiver Library
- IS-95A Mobile Station Transmitter Library
- IS-95A Base Station Receiver Library
- IS-95A Common Library

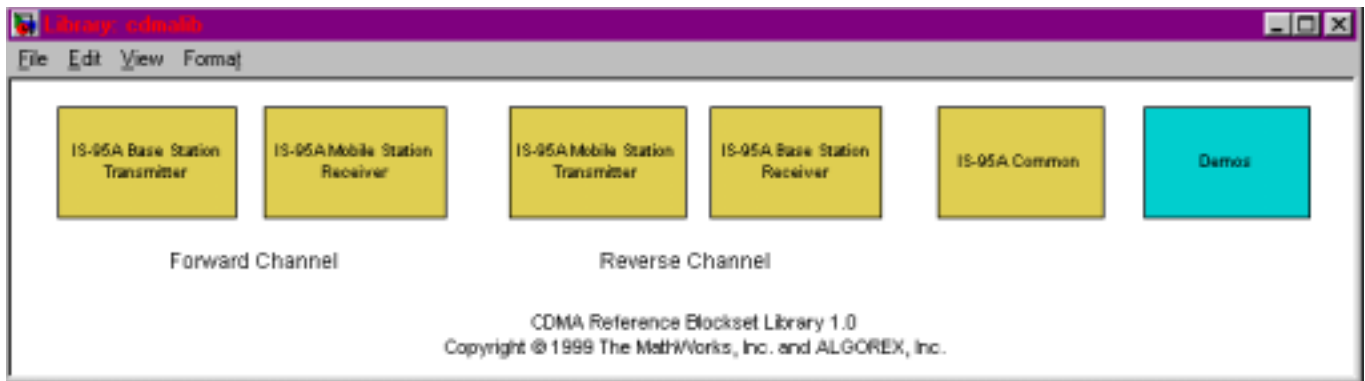

Figure 5.1

The figure 5.1 shows the CDMA toolbox main library.

All the blocks that are shown in the previous figure have sub-systems inside. That's why each of these blocks is called libraries. The names of each of these libraries are self-explanatory in the sense that each one contains all the sub-systems described in the previous sections.

As an example one of these libraries contents will be disclosed in order to understand how can we'll be able to build complex real CDMA systems using these blocks as the base of our model.

The following description was taken from the CDMA Toolbox user's guide from The Math Works™.

IS-95A Base Station Transmitter Library. The Base Station Transmitter Library provides the blocks required to perform the CDMA system base station or forward link transmitter functions.

Function	Block(s)
Channel coding for the transmit data at the base Station	IS-95A Fwd Ch Convolutional Encoder IS-95AFwd Ch Repeater/Derepeater IS-95A Fwd Ch Interleaver/Deinterleaver
Pseudorandom scrambling of the transmitted data based on the user-specific long code	IS-95A Fwd Ch Scrambler
Spreading of the data sources corresponding to the different channels	IS-95A Fwd Ch Base Station Transmitter Interface

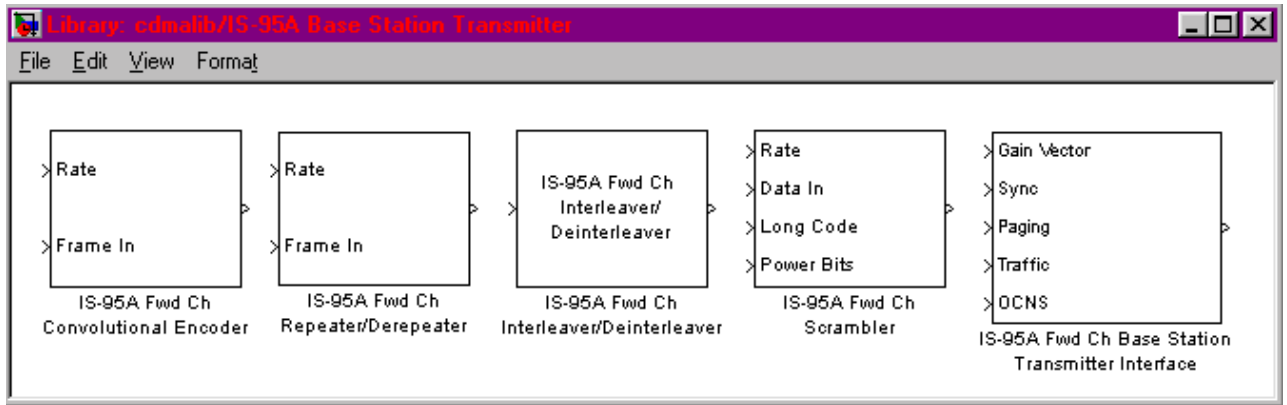

Figure 5.2

Figure 5.2 shows the Base Station Transmitter Library where we can notice that all these blocks are components of the forward CDMA channel as it was shown in a previous section of this project.

A detailed description of each of this individual sub-systems and the remaining libraries can be found in the CDMA Toolbox user's guide from The Math Works™.

With these introduction to this specific toolbox is easy to figure that the complexity of implement a simulation using this tool compared with a standard programming language like C or even Matlab® is much lower and less time consuming.

5.2 MODELS & SIMULATION RESULTS

Using some of the examples and demos as a guide in the CDMA toolbox we built the following systems:

5.2.1 IS-95A Reverse Traffic Channel Transmitter - Model

This system simulates the mobile station transmitter, that is, the IS95 reverse link. The system is comprised by :

- CRC generator
- Convolutional Encoder
- Symbol Repeater
- Interleaver
- Modulator and Spreader
- Transmission Filter

The importance of this simulation is, for example, when a designer needs to determine the max or min levels of the signals involved, so if it's possible to analyze the waveforms it would be easy to determine or predict these levels.

We can run this simulation model with different symbol rates, since we know that this is a variable parameter in an IS-95 system and we generate the information (the bits to transmit) with the Random Binary Generator.

The raw data corresponds to the speech frame generated at the vocoder.

We add redundancy with the CRC generator in order to provide error control on the system. The result of the CRC addition is convolutionally encoded for error protection by the Convolutional Encoder library block. This data is interleaved by the Interleaver / Deinterleaver block for protection against bursts. The IS95 Short Code Generator generates the short PN code, which is used for quadrature spreading as we can see in figure 5.3.

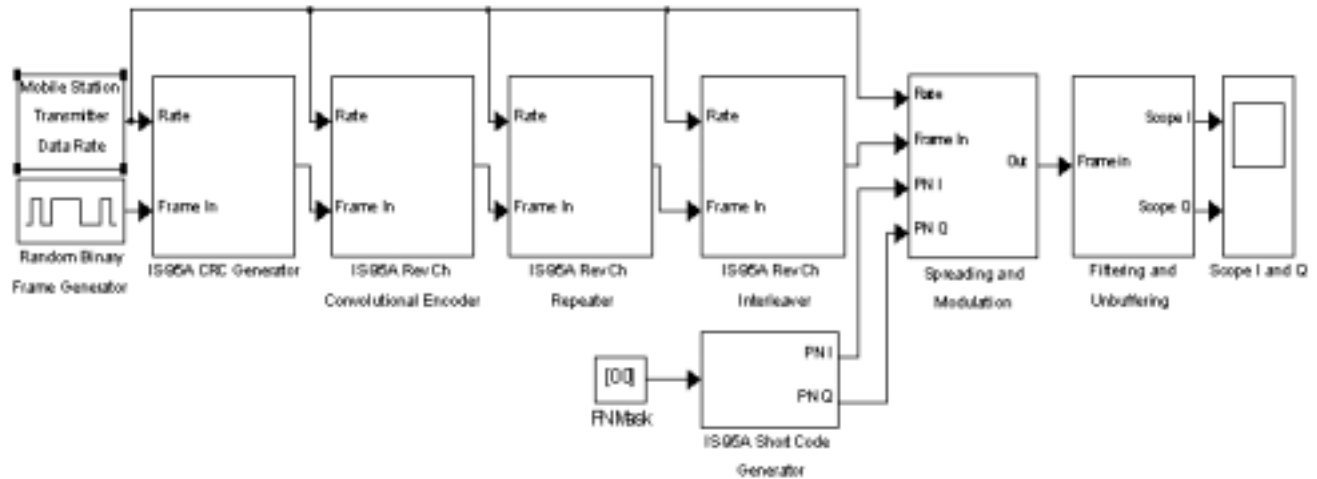

Figure 5.3

The Spreading and Modulation block performs the Walsh modulation and spreading with the long code. This block performs the short PN spreading also. The Filtering and Unbuffering subsystem implements the pulse shaping to generate the I and Q waveforms that can be displayed in the Scope (a virtual instrument).

5.2.2 IS-95A Reverse Traffic Channel Transmitter - Simulation Results.

As we mentioned in the previous section the simulation results are the In-phase and the Quadrature modulated signals. We run the simulation for different values of the data rate¹ which, when we run a value different than the full rate (9600 bps) in order to see the previously mentioned gate off.

So in the other cases where the bit rate is less than the full rate (4800, 2400 and 1200 bps) the display show that the waveform is gated off for part of the duration as the theory predicts.

The following figures shows the simulations results for the four different data rates.

¹ Remember a previous section where we mentioned the different values for the data rate: 9600, 4800, 2400 and 1200 bits per seconds.

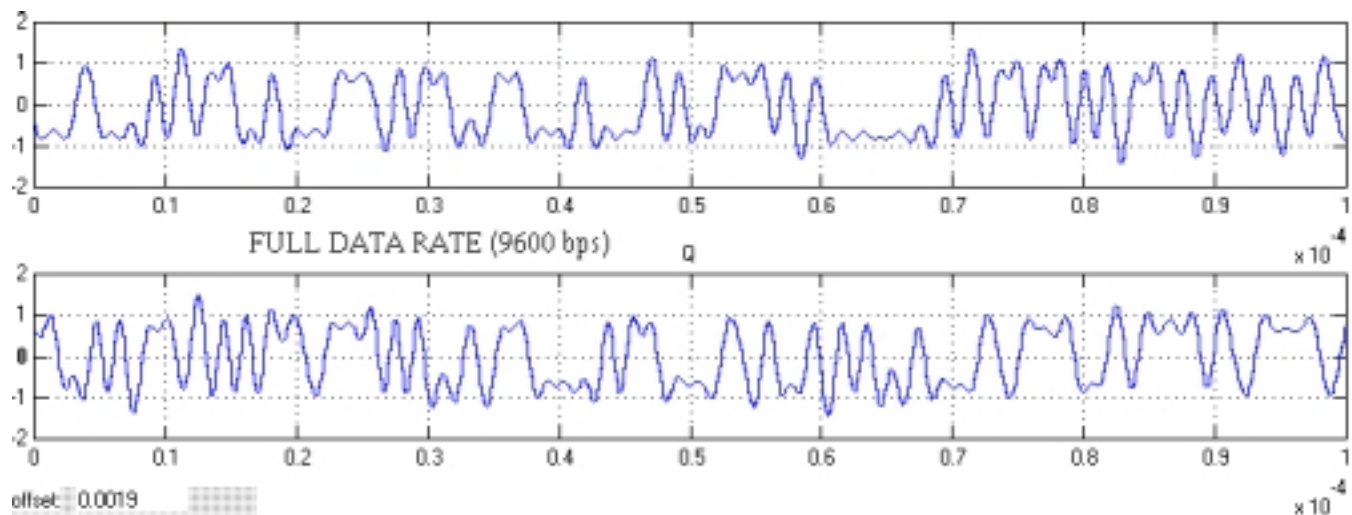

Figure 5.4 I and Q signals at a full data rate

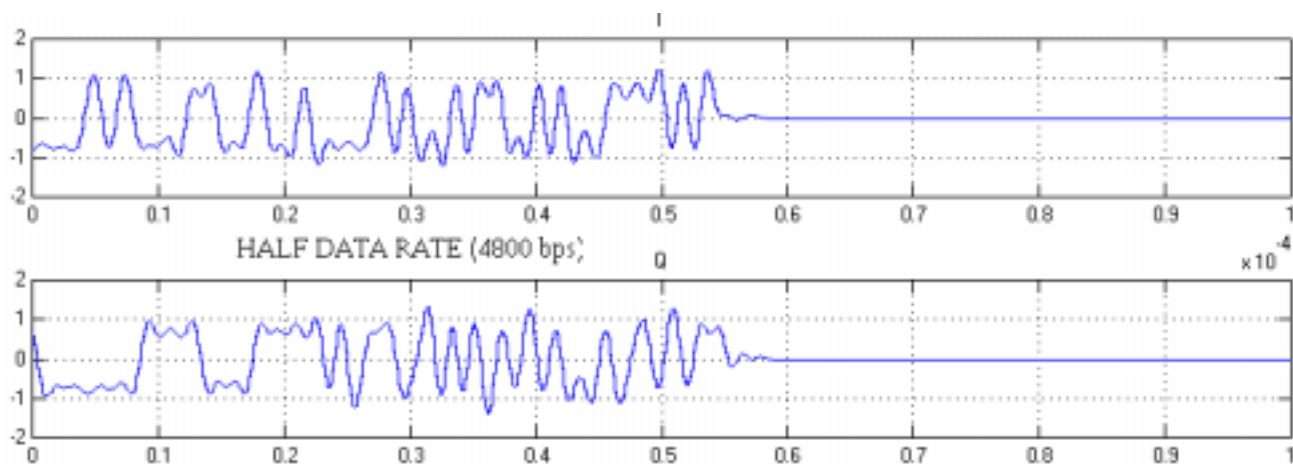

Figure 5.4 I and Q signals at a half data rate

When the simulation is running in real time, it's possible to see the duration of this gate-off phenomenon.

The reader interested in run more complex simulations can visit The Math Works internet web site in order to learn more about this tools.

6. CONCLUSIONS AND RECOMENDATIONS.

The scope of the project was to understand and explain as a system level, the standard IS-95 for Personal Communications Services (PCS), learn, understand and explain the benefits and nice features of the simulation tool Simulink® using the Communications and CDMA toolboxes.

This project could be very useful, as I mentioned before, for the Communications System Designer or Supervisor in order to, not only understand the basics of the CDMA system but also to learn more about powerful tools available in the market.

From the systems engineering perspective both, the analysis and simulation of the CDMA IS-95 system were successful.

I may run the simulation of more complex systems (with the multipath channel included, for example) but it could use a lot of time I don't have now and the concepts remain the same from the previous example.

7. REFERENCES

[1] *Rappaport, T.S., Wireless Communications-Principles and Practice, Prentice Hall, 1996.*

[2] *Rappaport T.S., Liberti Joseph, Smart Antennas for Wireless Communications, Prentice Hall, 1999.*

[3] *Viterby Andrew, CDMA – Principles of Spread Spectrum Communications, Addison Wesley, 1995*

[4] *Gibson Jerry, The Mobile Communications Handbook 2nd edition, CRC 1999.*

Material to read:

[5] *Bernard Sklar, Rayleigh Fading Channels in Mobile Digital Communications Systems - Part I: Characterization, IEEE Communications Magazine, Vol-35 #7, July 1997.*

[6] *Bernard Sklar, Rayleigh Fading Channels in Mobile Digital Communications Systems - Part II: Mitigation, IEEE Communications Magazine, Vol-35 #7, July 1997*

[7] The MATH WORKS, MATLAB ®, SIMULINK® , Communications Toolbox and CDMA Reference Blockset User's` Guides