

# MCR8M, MCR8N

Preferred Device

## Silicon Controlled Rectifiers

### Reverse Blocking Thyristors

Designed primarily for half-wave ac control applications, such as motor controls, heating controls, and power supplies; or wherever half-wave, silicon gate-controlled devices are needed.

- Blocking Voltage of 600 thru 800 Volts
- On-State Current Rating of 8 Amperes RMS at 80°C
- High Surge Current Capability — 80 Amperes
- Rugged, Economical TO220AB Package
- Glass Passivated Junctions for Reliability and Uniformity
- Minimum and Maximum Values of IGT, VGT and IH Specified for Ease of Design
- High Immunity to dv/dt — 100 V/μsec Minimum at 125°C
- Device Marking: Logo, Device Type, e.g., MCR8N, Date Code

#### MAXIMUM RATINGS (T<sub>J</sub> = 25°C unless otherwise noted)

Rating	Symbol	Value	Unit
Peak Repetitive Off-State Voltage <sup>(1)</sup> (T <sub>J</sub> = -40 to 125°C, Sine Wave, 50 to 60 Hz, Gate Open)	V <sub>DRM</sub> , V <sub>RRM</sub>	600 800	Volts
On-State RMS Current (180° Conduction Angles; T <sub>C</sub> = 80°C)	I <sub>T(RMS)</sub>	8.0	Amps
Peak Non-Repetitive Surge Current (One Full Cycle, 60 Hz, T <sub>C</sub> = 125°C)	I <sub>TSM</sub>	80	Amps
Circuit Fusing Consideration (t = 8.33 ms)	I <sup>2</sup> t	26.5	A <sup>2</sup> sec
Forward Peak Gate Power (Pulse Width ≤ 1.0 μs, T <sub>C</sub> = 80°C)	P <sub>GM</sub>	5.0	Watts
Forward Average Gate Power (t = 8.3 ms, T <sub>C</sub> = 80°C)	P <sub>G(AV)</sub>	0.5	Watt
Forward Peak Gate Current (Pulse Width ≤ 1.0 μs, T <sub>C</sub> = 80°C)	I <sub>GM</sub>	2.0	Amps
Operating Junction Temperature Range	T <sub>J</sub>	-40 to 125	°C
Storage Temperature Range	T <sub>stg</sub>	-40 to 150	°C

(1) V<sub>DRM</sub> and V<sub>RRM</sub> for all types can be applied on a continuous basis. Ratings apply for zero or negative gate voltage; positive gate voltage shall not be applied concurrent with negative potential on the anode. Blocking voltages shall not be tested with a constant current source such that the voltage ratings of the devices are exceeded.



**ON Semiconductor**

<http://onsemi.com>

**SCRs**  
**8 AMPERES RMS**  
**600 thru 800 VOLTS**

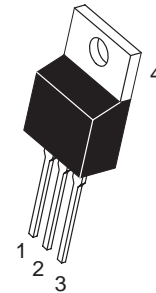

**TO-220AB**  
**CASE 221A**  
**STYLE 3**

#### PIN ASSIGNMENT

Pin	Assignment
1	Cathode
2	Anode
3	Gate
4	Anode

#### ORDERING INFORMATION

Device	Package	Shipping
MCR8M	TO220AB	50 Units/Rail
MCR8N	TO220AB	50 Units/Rail

**Preferred** devices are recommended choices for future use and best overall value.

# MCR8M, MCR8N

## THERMAL CHARACTERISTICS

Characteristic	Symbol	Value	Unit
Thermal Resistance — Junction to Case — Junction to Ambient	$R_{\theta JC}$ $R_{\theta JA}$	2.2 62.5	$^{\circ}\text{C}/\text{W}$
Maximum Lead Temperature for Soldering Purposes 1/8" from Case for 10 Seconds	$T_L$	260	$^{\circ}\text{C}$

## ELECTRICAL CHARACTERISTICS ( $T_J = 25^{\circ}\text{C}$ unless otherwise noted)

Characteristic	Symbol	Min	Typ	Max	Unit
----------------	--------	-----	-----	-----	------

## OFF CHARACTERISTICS

Peak Repetitive Forward or Reverse Blocking Current ( $V_D = \text{Rated } V_{DRM} \text{ and } V_{RRM}$ ; Gate Open)	$I_{DRM}$ , $I_{RRM}$	— —	— —	0.01 2.0	mA

## ON CHARACTERISTICS

Peak Forward On-State Voltage* ( $I_{TM} = 16 \text{ A}$ )	$V_{TM}$	—	—	1.8	Volts
Gate Trigger Current (Continuous dc) ( $V_D = 12 \text{ V}$ ; $R_L = 100 \Omega$ )	$I_{GT}$	2.0	7.0	15	mA
Holding Current ( $V_D = 12 \text{ V}$ , Gate Open, Initiating Current = 200 mA)	$I_H$	4.0	17	30	mA
Latch Current ( $V_D = 12 \text{ V}$ , $I_G = 15 \text{ mA}$ )	$I_L$	6.0	20	40	mA
Gate Trigger Voltage (Continuous dc) ( $V_D = 12 \text{ V}$ ; $100 \Omega$ )	$V_{GT}$	0.5	0.65	1.0	Volts
Gate Non-Trigger Voltage ( $V_D = 12 \text{ V}$ ; $R_L = 100 \Omega$ )	$V_{GD}$	0.2	—	—	Volts

## DYNAMIC CHARACTERISTICS

Critical Rate of Rise of Off-State Voltage ( $V_D = \text{Rated } V_{DRM}$ , Exponential Waveform, Gate Open, $T_J = 125^{\circ}\text{C}$ )	dv/dt	100	250	—	V/ $\mu\text{s}$
Critical Rate of Rise of On-State Current IPK = 50 A, Pw = 40 $\mu\text{sec}$ , diG/dt = 1 A/ $\mu\text{sec}$ , Igt = 50 mA	di/dt	—	—	50	A/ $\mu\text{s}$

\*Indicates Pulse Test: Pulse Width  $\leq 2.0 \text{ ms}$ , Duty Cycle  $\leq 2\%$ .

# MCR8M, MCR8N

## Voltage Current Characteristic of SCR

Symbol	Parameter
$V_{DRM}$	Peak Repetitive Off State Forward Voltage
$I_{DRM}$	Peak Forward Blocking Current
$V_{RRM}$	Peak Repetitive Off State Reverse Voltage
$I_{RRM}$	Peak Reverse Blocking Current
$V_{TM}$	Peak On State Voltage
$I_H$	Holding Current

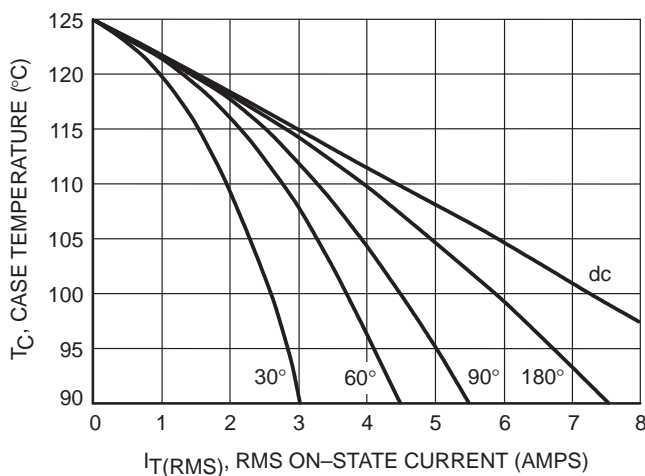
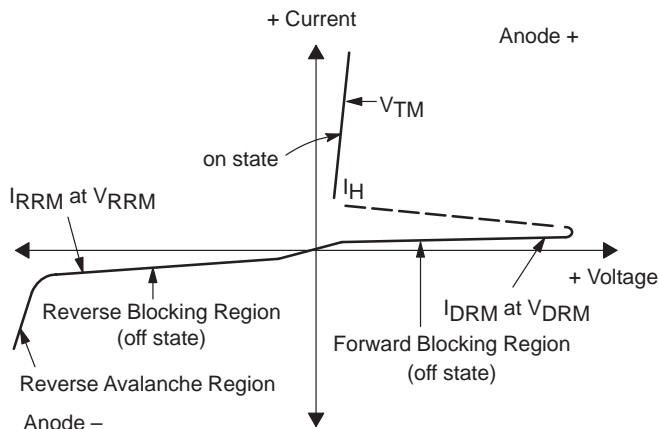

Figure 1. Typical RMS Current Derating

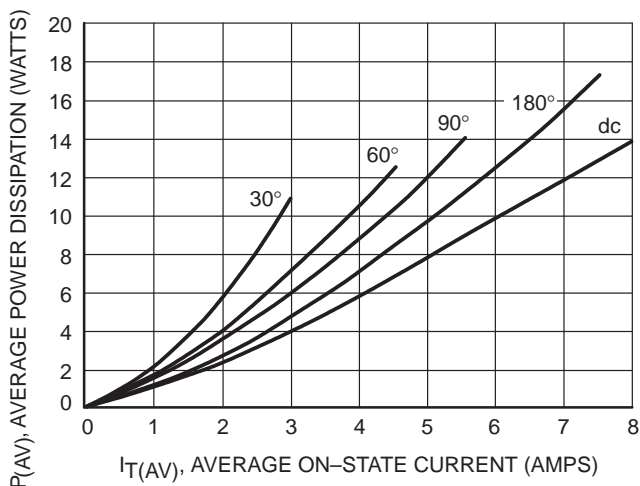

Figure 2. On-State Power Dissipation

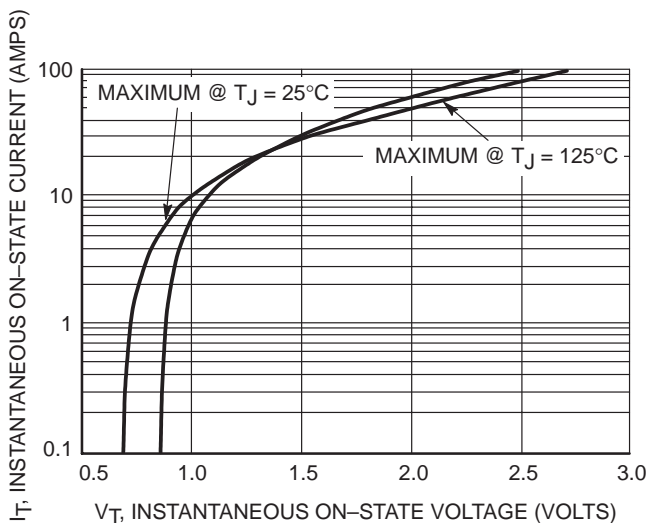

Figure 3. Typical On-State Characteristics

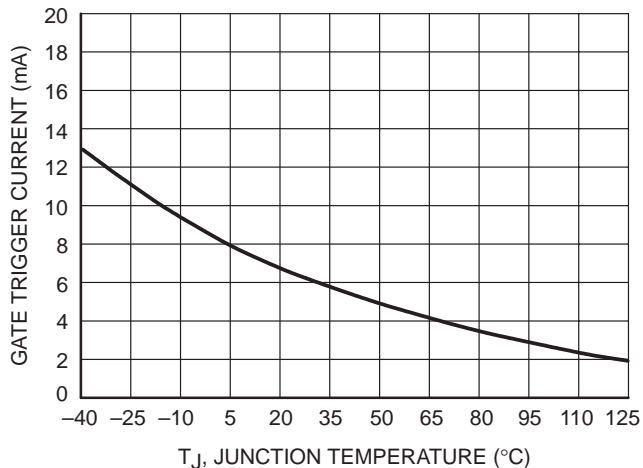

Figure 4. Typical Gate Trigger Current versus Junction Temperature

# MCR8M, MCR8N

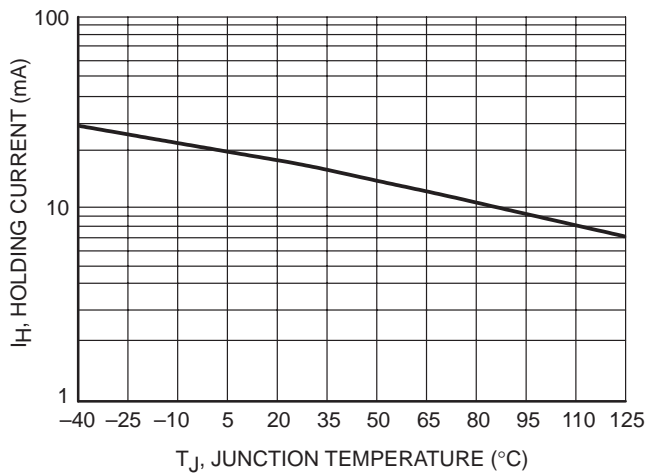

Figure 5. Typical Holding Current versus Junction Temperature

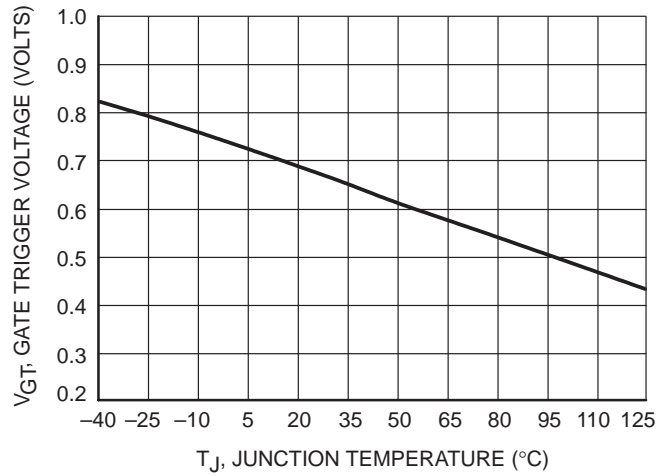

Figure 6. Typical Gate Trigger Voltage versus Junction Temperature

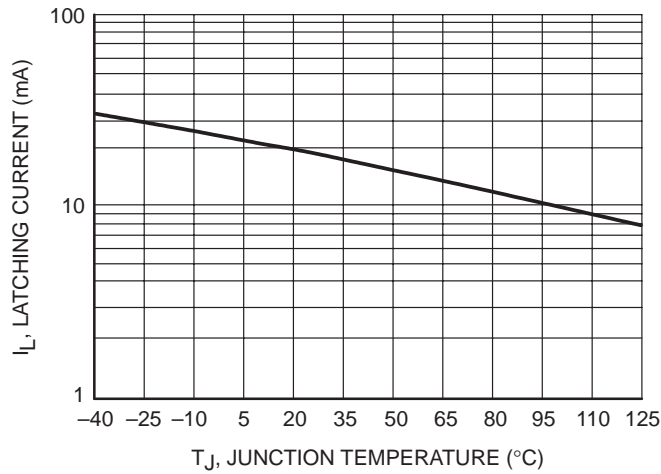
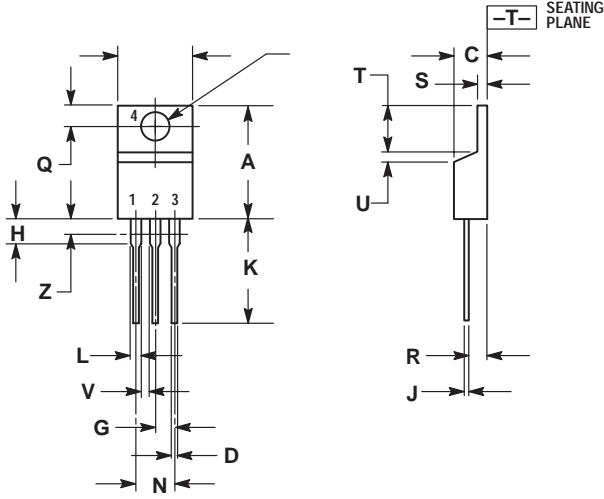

Figure 7. Typical Latching Current versus Junction Temperature

# MCR8M, MCR8N

## PACKAGE DIMENSIONS

TO-220AB  
CASE 221A-09  
ISSUE Z



- NOTES:
1. DIMENSIONING AND TOLERANCING PER ANSI Y14.5M, 1982.
  2. CONTROLLING DIMENSION: INCH.
  3. DIMENSION Z DEFINES A ZONE WHERE ALL BODY AND LEAD IRREGULARITIES ARE ALLOWED.

DIM	INCHES		MILLIMETERS	
	MIN	MAX	MIN	MAX
A	0.570	0.620	14.48	15.75
B	0.380	0.405	9.66	10.28
C	0.160	0.190	4.07	4.82
D	0.025	0.035	0.64	0.88
F	0.142	0.147	3.61	3.73
G	0.095	0.105	2.42	2.66
H	0.110	0.155	2.80	3.93
J	0.018	0.025	0.46	0.64
K	0.500	0.562	12.70	14.27
L	0.045	0.060	1.15	1.52
N	0.190	0.210	4.83	5.33
Q	0.100	0.120	2.54	3.04
R	0.080	0.110	2.04	2.79
S	0.045	0.055	1.15	1.39
T	0.235	0.255	5.97	6.47
U	0.000	0.050	0.00	1.27
V	0.045	---	1.15	---
Z	---	0.080	---	2.04

- STYLE 3:  
PIN 1. CATHODE  
2. ANODE  
3. GATE  
4. ANODE

**Notes**

## Notes

# MCR8M, MCR8N

**ON Semiconductor** and  are trademarks of Semiconductor Components Industries, LLC (SCILLC). SCILLC reserves the right to make changes without further notice to any products herein. SCILLC makes no warranty, representation or guarantee regarding the suitability of its products for any particular purpose, nor does SCILLC assume any liability arising out of the application or use of any product or circuit, and specifically disclaims any and all liability, including without limitation special, consequential or incidental damages. "Typical" parameters which may be provided in SCILLC data sheets and/or specifications can and do vary in different applications and actual performance may vary over time. All operating parameters, including "Typicals" must be validated for each customer application by customer's technical experts. SCILLC does not convey any license under its patent rights nor the rights of others. SCILLC products are not designed, intended, or authorized for use as components in systems intended for surgical implant into the body, or other applications intended to support or sustain life, or for any other application in which the failure of the SCILLC product could create a situation where personal injury or death may occur. Should Buyer purchase or use SCILLC products for any such unintended or unauthorized application, Buyer shall indemnify and hold SCILLC and its officers, employees, subsidiaries, affiliates, and distributors harmless against all claims, costs, damages, and expenses, and reasonable attorney fees arising out of, directly or indirectly, any claim of personal injury or death associated with such unintended or unauthorized use, even if such claim alleges that SCILLC was negligent regarding the design or manufacture of the part. SCILLC is an Equal Opportunity/Affirmative Action Employer.

## PUBLICATION ORDERING INFORMATION

### **NORTH AMERICA Literature Fulfillment:**

Literature Distribution Center for ON Semiconductor  
P.O. Box 5163, Denver, Colorado 80217 USA  
**Phone:** 303-675-2175 or 800-344-3860 Toll Free USA/Canada  
**Fax:** 303-675-2176 or 800-344-3867 Toll Free USA/Canada  
**Email:** ONlit@hibbertco.com  
Fax Response Line: 303-675-2167 or 800-344-3810 Toll Free USA/Canada

**N. American Technical Support:** 800-282-9855 Toll Free USA/Canada

**EUROPE:** LDC for ON Semiconductor – European Support

**German Phone:** (+1) 303-308-7140 (M-F 1:00pm to 5:00pm Munich Time)  
**Email:** ONlit-german@hibbertco.com  
**French Phone:** (+1) 303-308-7141 (M-F 1:00pm to 5:00pm Toulouse Time)  
**Email:** ONlit-french@hibbertco.com  
**English Phone:** (+1) 303-308-7142 (M-F 12:00pm to 5:00pm UK Time)  
**Email:** ONlit@hibbertco.com

**EUROPEAN TOLL-FREE ACCESS\*: 00-800-4422-3781**

\*Available from Germany, France, Italy, England, Ireland

### **CENTRAL/SOUTH AMERICA:**

**Spanish Phone:** 303-308-7143 (Mon-Fri 8:00am to 5:00pm MST)  
**Email:** ONlit-spanish@hibbertco.com

**ASIA/PACIFIC:** LDC for ON Semiconductor – Asia Support

**Phone:** 303-675-2121 (Tue-Fri 9:00am to 1:00pm, Hong Kong Time)  
Toll Free from Hong Kong & Singapore:  
**001-800-4422-3781**  
**Email:** ONlit-asia@hibbertco.com

**JAPAN:** ON Semiconductor, Japan Customer Focus Center  
4-32-1 Nishi-Gotanda, Shinagawa-ku, Tokyo, Japan 141-8549

**Phone:** 81-3-5740-2745  
**Email:** r14525@onsemi.com

**ON Semiconductor Website:** <http://onsemi.com>

For additional information, please contact your local Sales Representative.

This datasheet has been download from:

[www.datasheetcatalog.com](http://www.datasheetcatalog.com)

Datasheets for electronics components.