

**DUAL-J-K MASTER-SLAVE FLIP-FLOP**

- SET-RESET CAPABILITY
- STATIC FLIP-FLOP OPERATION - RETAINS STATE INDEFINITELY WITH CLOCK LEVEL EITHER "HIGH" OR "LOW"
- MEDIUM SPEED OPERATION - 16MHz (typ. clock toggle rate at 10V)
- STANDARDIZED SYMMETRICAL OUTPUT CHARACTERISTICS
- QUIESCENT CURRENT SPECIFIED TO 20V FOR HCC DEVICE
- INPUT CURRENT OF 100nA AT 18V AND 25°C FOR HCC DEVICE
- 100% TESTED FOR QUIESCENT CURRENT
- MEETS ALL REQUIREMENTS OF JEDEC TENTATIVE STANDARD N<sup>o</sup>. 13A, "STANDARD SPECIFICATIONS FOR DESCRIPTION OF "B" SERIES CMOS DEVICES".

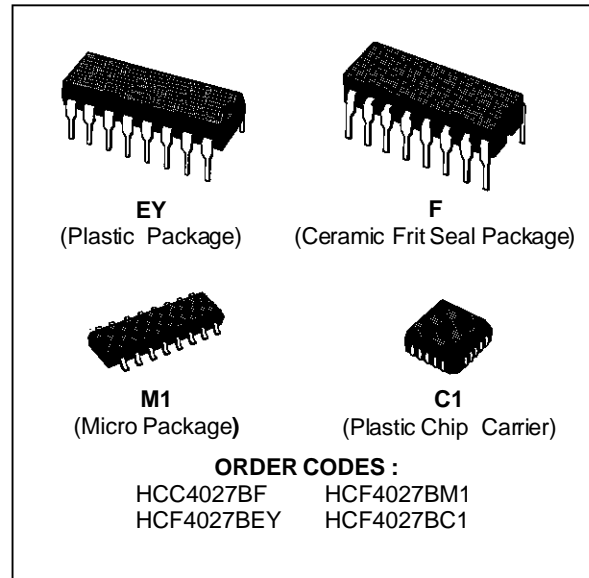

**DESCRIPTION**

The **HCC4027B** (extended temperature range) and **HCF4027B** (intermediate temperature range) are monolithic integrated circuit, available in 16-lead dual in-line plastic or ceramic package and plastic micro package.

The **HCC/HCF4027B** is a single monolithic chip integrated circuit containing two identical complementary-symmetry J-K master-slave flip-flops. Each flip-flop has provisions for individual J, K, Set, Reset, and Clock input signals, Buffered Q and  $\bar{Q}$  signals are provided as outputs. This input-output arrangement provides for compatible operation with the **HCC/HCF4013B** dual D-type flip-flop.

The **HCC/HCF4027B** is useful in performing control, register, and toggle functions. Logic levels present at the J and K inputs along with internal self-steering control the state of each flip-flop ; changes in the flip-flop state are synchronous with the positive-going transition of the clock pulse. Set and reset functions are independent of the clock and are initiated when a high level signal is present at either the Set or Reset input.

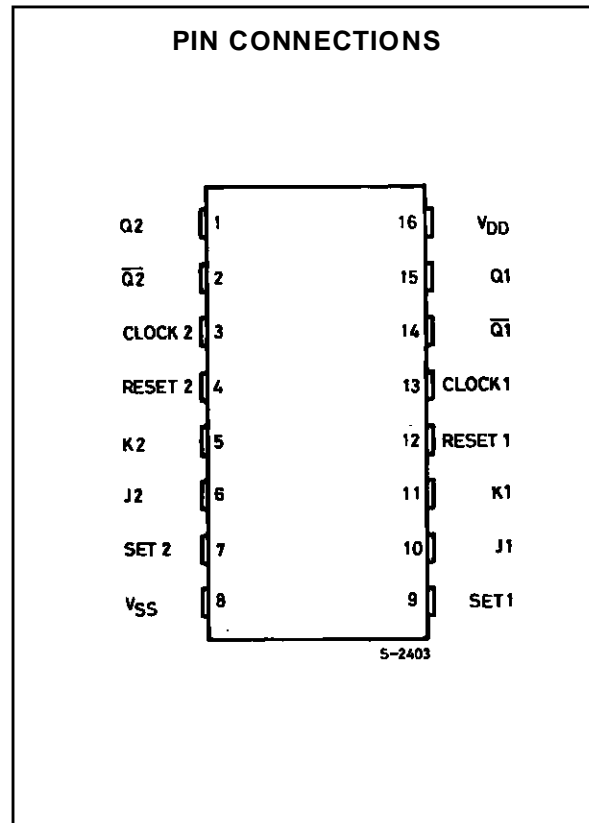

# HCC/HCF4027B

## FUNCTIONAL DIAGRAM

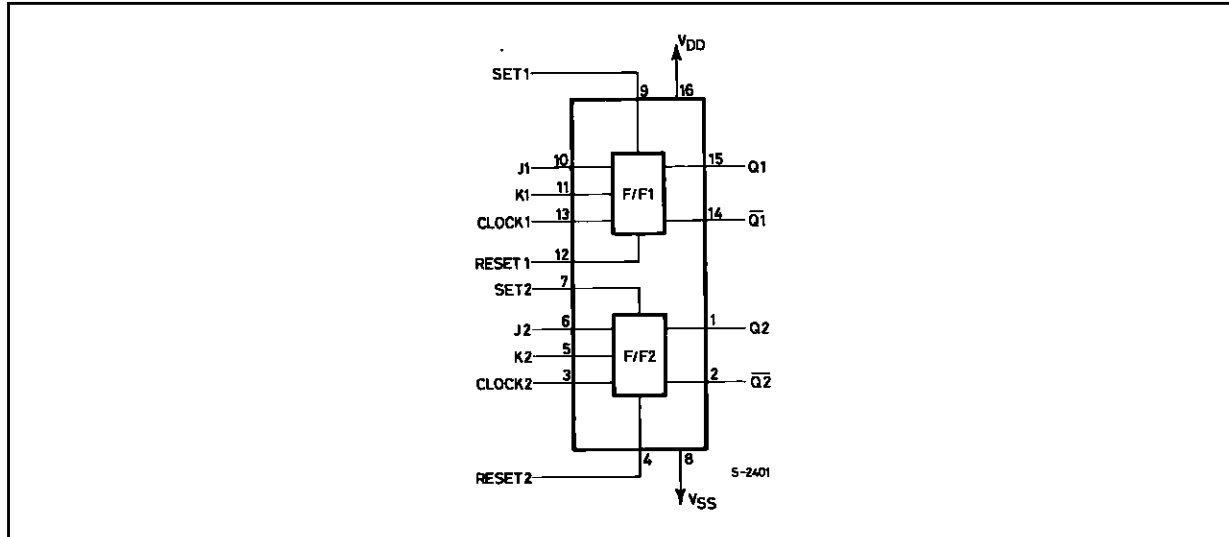

## ABSOLUTE MAXIMUM RATINGS

Symbol	Parameter	Value	Unit
$V_{DD}^*$	Supply Voltage : <b>HCC</b> Types <b>HCF</b> Types	- 0.5 to + 20 - 0.5 to + 18	V
$V_i$	Input Voltage	- 0.5 to $V_{DD} + 0.5$	V
$I_i$	DC Input Current (any one input)	$\pm 10$	mA
$P_{tot}$	Total Power Dissipation (per package) Dissipation per Output Transistor for $T_{op} =$ Full Package-temperature Range	200 100	mW
$T_{op}$	Operating Temperature : <b>HCC</b> Types <b>HCF</b> Types	- 55 to + 125 - 40 to + 85	$^{\circ}C$
$T_{stg}$	Storage Temperature	- 65 to + 150	$^{\circ}C$

Stresses above those listed under "Absolute Maximum Ratings" may cause permanent damage to the device. This is a stress rating only and functional operation of the device at these or any other conditions above those indicated in the operational sections of this specification is not implied. Exposure to absolute maximum rating conditions for external periods may affect device reliability.

\* All voltage values are referred to  $V_{SS}$  pin voltage .

## RECOMMENDED OPERATING CONDITIONS

Symbol	Parameter	Value	Unit
$V_{DD}$	Supply Voltage : <b>HCC</b> Types <b>HCF</b> Types	3 to 18 3 to 15	V
$V_i$	Input Voltage	0 to $V_{DD}$	V
$T_{op}$	Operating Temperature : <b>HCC</b> Types <b>HCF</b> Types	- 55 to + 125 - 40 to + 85	$^{\circ}C$

**LOGIC DIAGRAM AND TRUTH TABLE**

ONE OF TWO IDENTICAL J-K FLIP-FLOPS

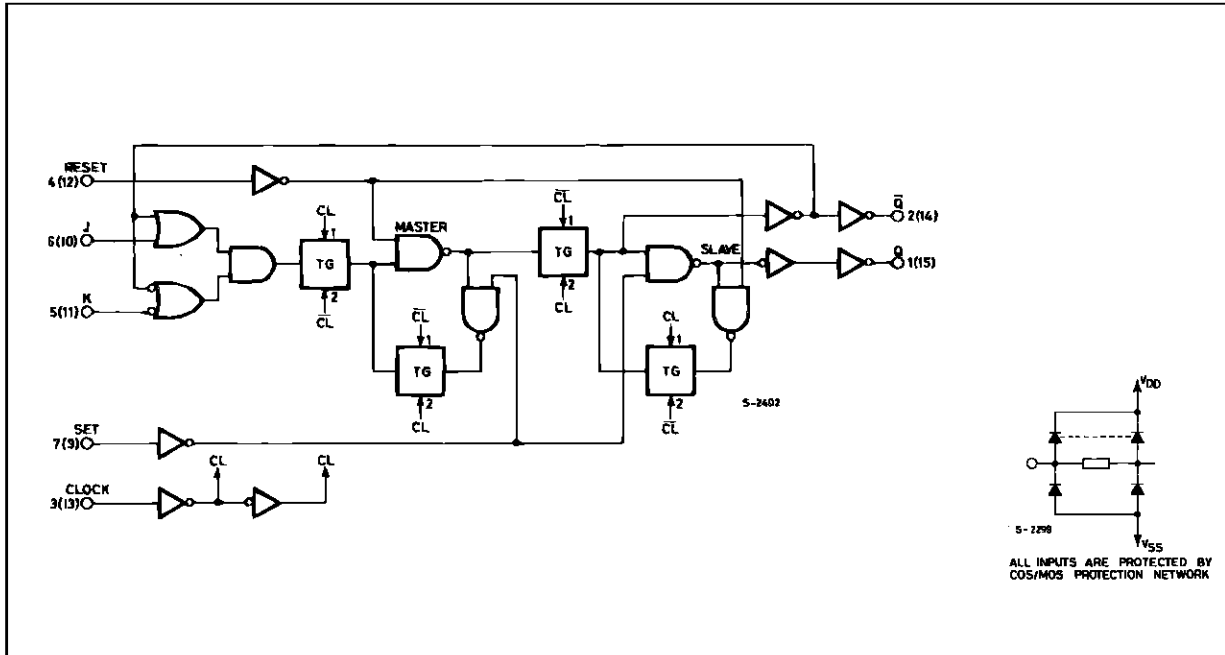

**TRUTH TABLE**

Present State				Output	CL <sup>Δ</sup>	Next State		
Inputs			Q			Outputs		
J	K	S				Q	$\bar{Q}$	
I	X	O	O	O	┌	I	O	
X	O	O	O	I	┌	I	O	
O	X	O	O	O	┌	O	I	
X	I	O	O	I	┌	O	I	
X	X	O	O	X	┌			← No Change
X	X	I	O	X	X	I	O	
X	X	O	I	X	X	O	I	
X	X	I	I	X	X	I	I	

LOGIC I = HIGH LEVEL  
 LOGIC O = LOW LEVEL  
 Δ - LEVEL CHANGE  
 X - DONT CARE

# HCC/HCF4027B

## STATIC ELECTRICAL CHARACTERISTICS (over recommended operating conditions)

Symbol	Parameter		Test Conditions				Value						Unit	
			V <sub>I</sub> (V)	V <sub>O</sub> (V)	I <sub>O</sub>   ( $\mu$ A)	V <sub>DD</sub> (V)	T <sub>Low</sub> *		25°C			T <sub>High</sub> *		
							Min.	Max.	Min.	Typ.	Max.	Min.		Max.
I <sub>L</sub>	Quiescent Current	HCC Types	0/ 5			5		1		0.02	1		30	$\mu$ A
			0/10			10		2		0.02	2		60	
			0/15			15		4		0.02	4		120	
			0/20			20		20		0.04	20		600	
		HCF Types	0/ 5			5		4		0.02	4		30	
			0/10			10		8		0.02	8		60	
V <sub>OH</sub>	Output High Voltage		0/ 5		< 1	5	4.95		4.95			4.95	V	
			0/10		< 1	10	9.95		9.95			9.95		
			0/15		< 1	15	14.95		14.95			14.95		
V <sub>OL</sub>	Output Low Voltage		5/0		< 1	5		0.05			0.05		V	
			10/0		< 1	10		0.05			0.05			
			15/0		< 1	15		0.05			0.05			
V <sub>IH</sub>	Input High Voltage			0.5/4.5	< 1	5	3.5		3.5			3.5	V	
				1/9	< 1	10	7		7			7		
				1.5/13.5	< 1	15	11		11			11		
V <sub>IL</sub>	Input Low Voltage			4.5/0.5	< 1	5		1.5			1.5		V	
				9/1	< 1	10		3			3			
				13.5/1.5	< 1	15		4			4			
I <sub>OH</sub>	Output Drive Current	HCC Types	0/ 5	2.5		5	- 2		- 1.6	- 3.2		- 1.15	mA	
			0/ 5	4.6		5	- 0.64		- 0.51	- 1		- 0.36		
			0/10	9.5		10	- 1.6		- 1.3	- 2.6		- 0.9		
			0/15	13.5		15	- 4.2		- 3.4	- 6.8		- 2.4		
		HCF Types	0/ 5	2.5		5	- 1.53		- 1.36	- 3.2		- 1.1		
			0/ 5	4.6		5	- 0.52		- 0.44	- 1		- 0.36		
			0/10	9.5		10	- 1.3		- 1.1	- 2.6		- 0.9		
			0/15	13.5		15	- 3.6		- 3.0	- 6.8		- 2.4		
I <sub>OL</sub>	Output Sink Current	HCC Types	0/ 5	0.4		5	0.64		0.51	1		0.36	mA	
			0/10	0.5		10	1.6		1.3	2.6		0.9		
			0/15	1.5		15	4.2		3.4	6.8		2.4		
		HCF Types	0/ 5	0.4		5	0.52		0.44	1		0.36		
			0/10	0.5		10	1.3		1.1	2.6		0.9		
			0/15	1.5		15	3.6		3.0	6.8		2.4		
I <sub>IH</sub> , I <sub>IL</sub>	Input Leakage Current	HCC Types	0/18	Any Input		18		$\pm$ 0.1		$\pm$ 10 <sup>-5</sup>	$\pm$ 0.1		$\pm$ 1	$\mu$ A
		HCF Types	0/15	Any Input		15		$\pm$ 0.3		$\pm$ 10 <sup>-5</sup>	$\pm$ 0.3		$\pm$ 1	
C <sub>I</sub>	Input Capacitance		Any Input						5	7.5			pF	

\* T<sub>Low</sub> = - 55°C for HCC device ; - 40°C for HCF device.

\* T<sub>High</sub> = + 125°C for HCC device ; + 85°C for HCF device.

The Noise Margin for both "1" and "0" level is : 1V min. with V<sub>DD</sub> = 5V, 2V min. with V<sub>DD</sub> = 10V, 2.5 V min. with V<sub>DD</sub> = 15V.

**DYNAMIC ELECTRICAL CHARACTERISTICS** ( $T_{amb} = 25^{\circ}\text{C}$ ,  $C_L = 50\text{pF}$ ,  $R_L = 200\text{k}\Omega$ , typical temperature coefficient for all  $V_{DD} = 0.3\%/^{\circ}\text{C}$  values, all input rise and fall time = 20ns)

Symbol	Parameter		Test Conditions	Value			Unit	
				$V_{DD}$ (V)	Min.	Typ.		Max.
$t_{PLH}$ , $t_{PHL}$	Propagation Delay Time	Clock to Q or $\bar{Q}$ Outputs		5		150	300	ns
				10		65	130	
				15		45	90	
$t_{PLH}$	Propagation Delay Time	Set to Q or Reset to $\bar{Q}$		5		150	300	ns
				10		65	130	
				15		45	90	
$t_{PHL}$	Propagation Delay Time	Set to $\bar{Q}$ or Reset to Q		5		200	400	ns
				10		85	170	
				15		60	120	
$t_{THL}$ , $t_{TLH}$	Transition Time			5		100	200	ns
				10		50	100	
				15		40	80	
$t_W$	Pulse Width	Clock		5	140	70		ns
				10	60	30		
				15	40	20		
$t_W$	Pulse Width	Set or Reset		5	180	90		ns
				10	80	40		
				15	50	25		
$t_r$ , $t_f$	Clock Input Rise or Fall Time			5			15	$\mu\text{s}$
				10			4	
				15			1	
$t_{setup}$	Setup Time	Data		5	200	100		ns
				10	75	35		
				15	50	25		
$f_{max}$	Maximum Clock Input Frequency *	Toggle Mode		5	3.5	7		MHz
				10	8	16		
				15	12	24		

\* Input  $t_r$ ,  $t_f = 5\text{ns}$ .

Typical Output Low (sink) Current Characteristics.

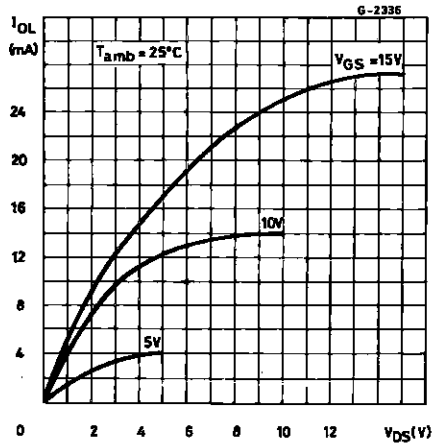

Minimum Output Low (sink) Current Characteristics.

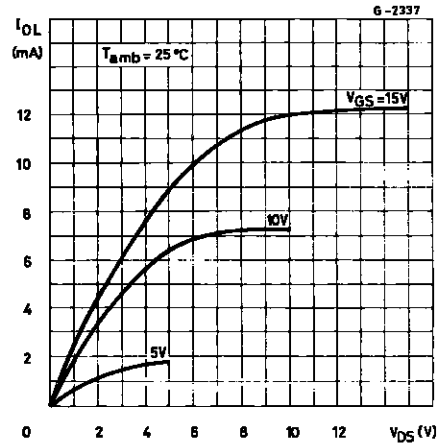

Typical Output High (source) Current Characteristics.

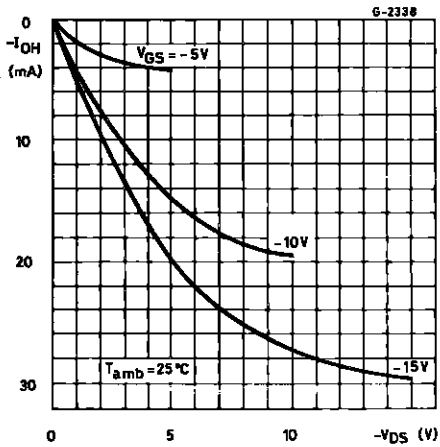

Minimum Output High (source) Current Characteristics.

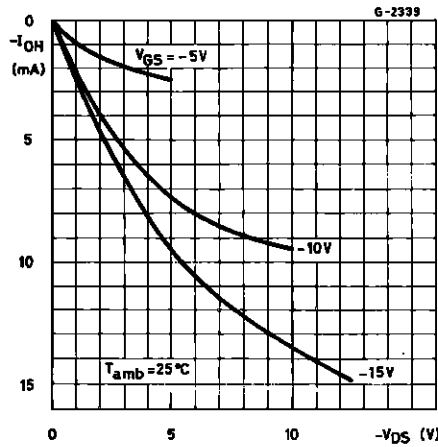

Typical Propagation Delay Time vs. Load Capacitance (CLOCK or SET to Q, CLOCK or RESET to  $\bar{Q}$ ).

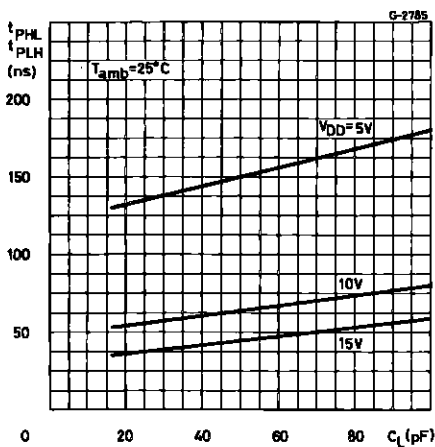

Typical Propagation Delay Time vs. Load Capacitance (SET to Q or RESET to Q).

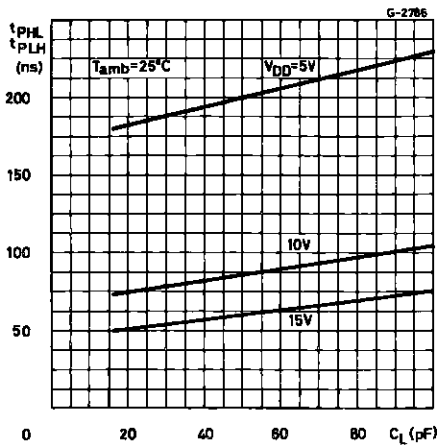

Typical Maximum Clock Frequency vs. Supply Voltage (Toggle Mode).

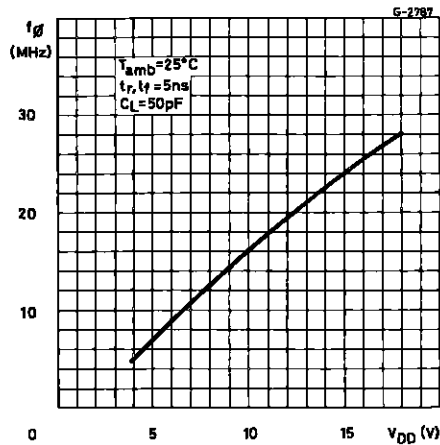

Typical Dynamic Power Dissipation/ Per Device vs. Frequency.

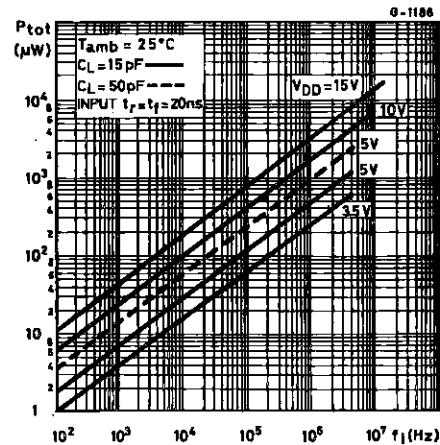

TEST CIRCUITS

Quiescent Device Current.

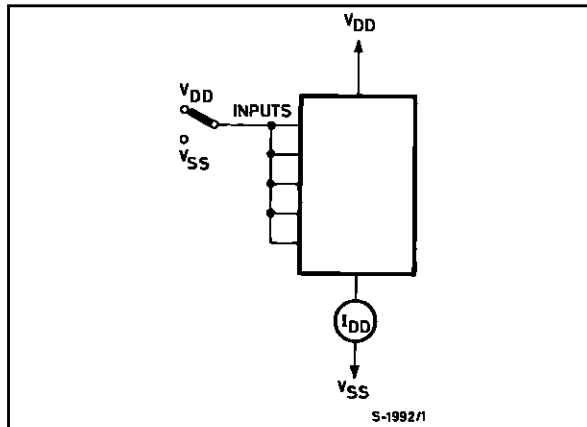

Input Voltage.

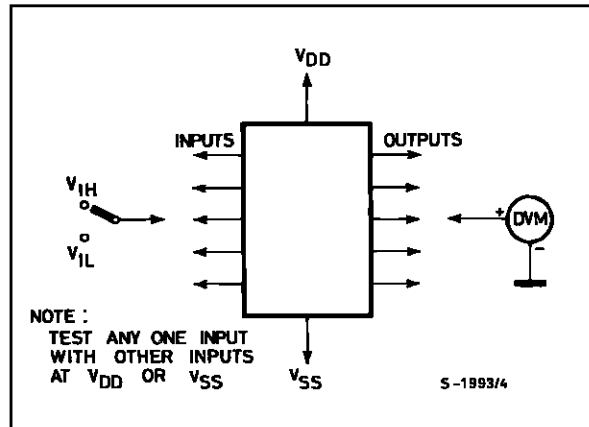

Input Leakage Current.

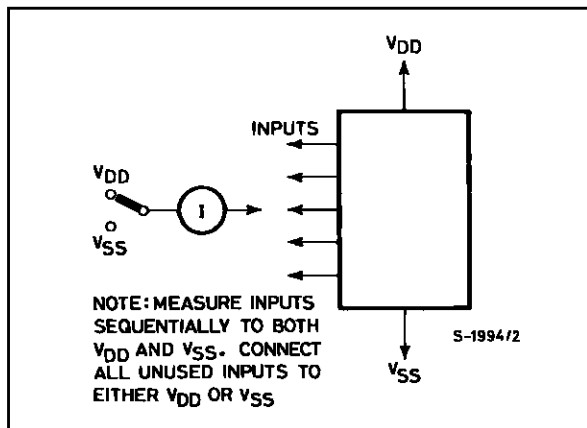

**Plastic DIP16 (0.25) MECHANICAL DATA**

DIM.	mm			inch		
	MIN.	TYP.	MAX.	MIN.	TYP.	MAX.
a1	0.51			0.020		
B	0.77		1.65	0.030		0.065
b		0.5			0.020	
b1		0.25			0.010	
D			20			0.787
E		8.5			0.335	
e		2.54			0.100	
e3		17.78			0.700	
F			7.1			0.280
I			5.1			0.201
L		3.3			0.130	
Z			1.27			0.050

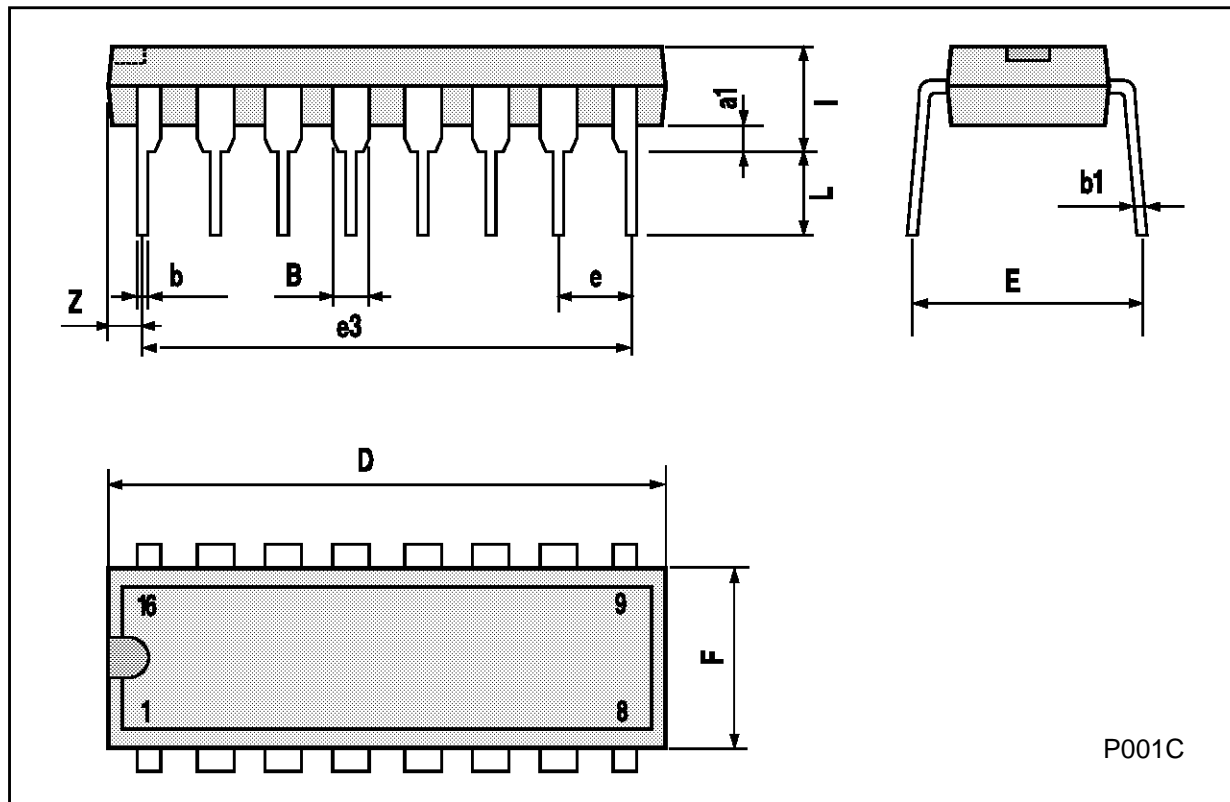

P001C

**Ceramic DIP16/1 MECHANICAL DATA**

DIM.	mm			inch		
	MIN.	TYP.	MAX.	MIN.	TYP.	MAX.
A			20			0.787
B			7			0.276
D		3.3			0.130	
E	0.38			0.015		
e3		17.78			0.700	
F	2.29		2.79	0.090		0.110
G	0.4		0.55	0.016		0.022
H	1.17		1.52	0.046		0.060
L	0.22		0.31	0.009		0.012
M	0.51		1.27	0.020		0.050
N			10.3			0.406
P	7.8		8.05	0.307		0.317
Q			5.08			0.200



**SO16 (Narrow) MECHANICAL DATA**

DIM.	mm			inch		
	MIN.	TYP.	MAX.	MIN.	TYP.	MAX.
A			1.75			0.068
a1	0.1		0.2	0.004		0.007
a2			1.65			0.064
b	0.35		0.46	0.013		0.018
b1	0.19		0.25	0.007		0.010
C		0.5			0.019	
c1	45° (typ.)					
D	9.8		10	0.385		0.393
E	5.8		6.2	0.228		0.244
e		1.27			0.050	
e3		8.89			0.350	
F	3.8		4.0	0.149		0.157
G	4.6		5.3	0.181		0.208
L	0.5		1.27	0.019		0.050
M			0.62			0.024
S	8° (max.)					

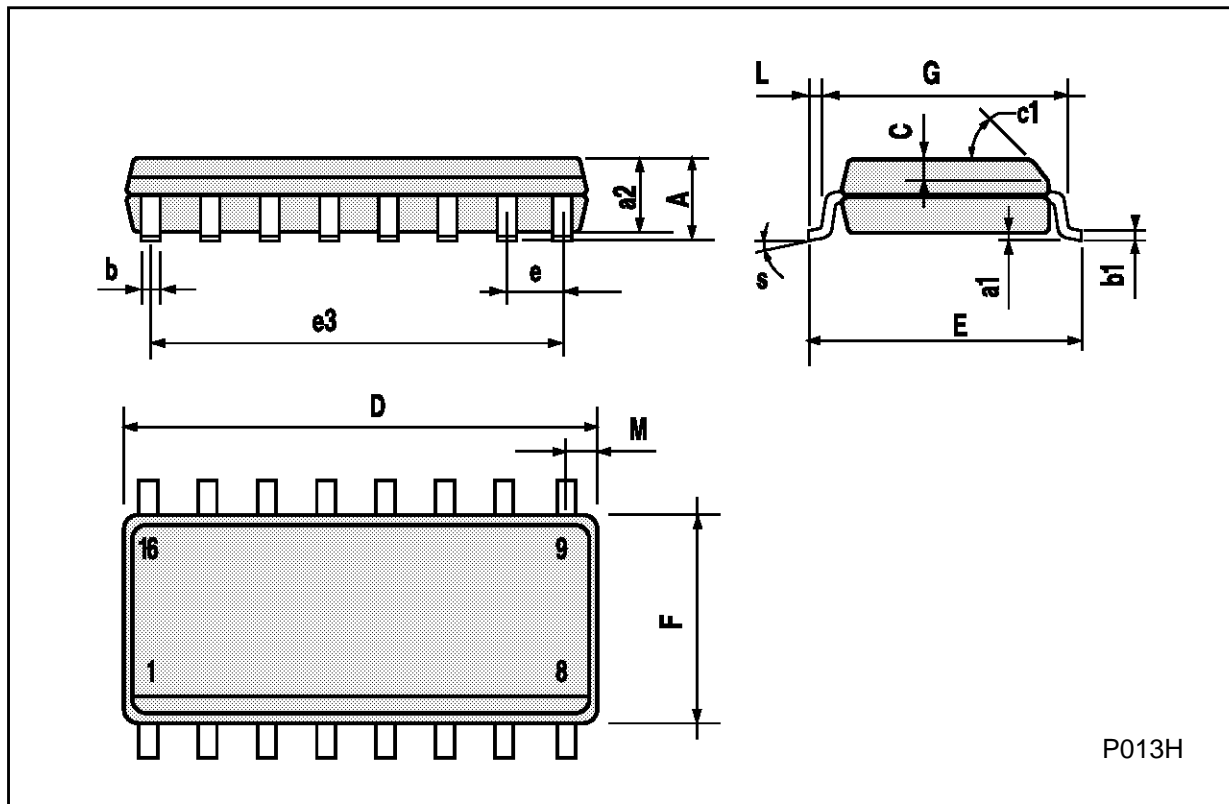

P013H

**PLCC20 MECHANICAL DATA**

DIM.	mm			inch		
	MIN.	TYP.	MAX.	MIN.	TYP.	MAX.
A	9.78		10.03	0.385		0.395
B	8.89		9.04	0.350		0.356
D	4.2		4.57	0.165		0.180
d1		2.54			0.100	
d2		0.56			0.022	
E	7.37		8.38	0.290		0.330
e		1.27			0.050	
e3		5.08			0.200	
F		0.38			0.015	
G			0.101			0.004
M		1.27			0.050	
M1		1.14			0.045	

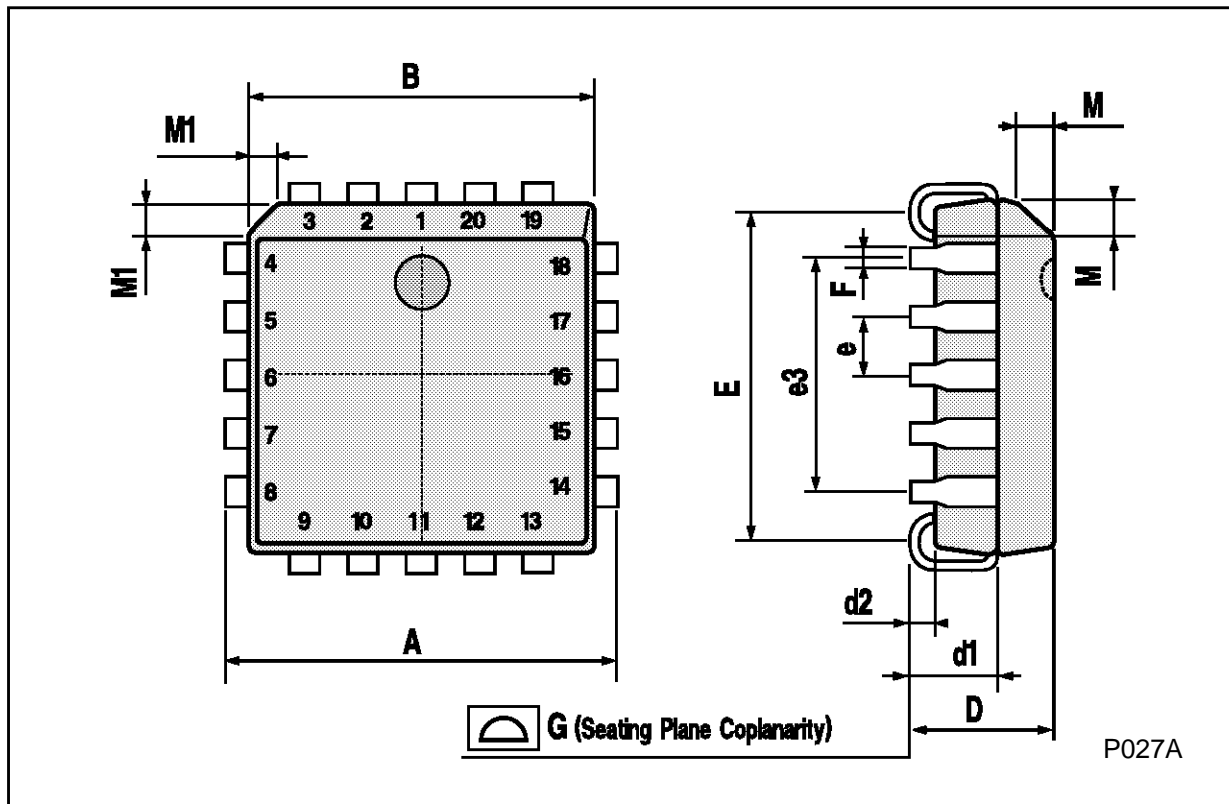

Information furnished is believed to be accurate and reliable. However, SGS-THOMSON Microelectronics assumes no responsibility for the consequences of use of such information nor for any infringement of patents or other rights of third parties which may result from its use. No license is granted by implication or otherwise under any patent or patent rights of SGS-THOMSON Microelectronics. Specifications mentioned in this publication are subject to change without notice. This publication supersedes and replaces all information previously supplied. SGS-THOMSON Microelectronics products are not authorized for use as critical components in life support devices or systems without express written approval of SGS-THOMSON Microelectronics.

© 1994 SGS-THOMSON Microelectronics - All Rights Reserved

SGS-THOMSON Microelectronics GROUP OF COMPANIES

Australia - Brazil - France - Germany - Hong Kong - Italy - Japan - Korea - Malaysia - Malta - Morocco - The Netherlands -  
Singapore - Spain - Sweden - Switzerland - Taiwan - Thailand - United Kingdom - U.S.A

This datasheet has been download from:

[www.datasheetcatalog.com](http://www.datasheetcatalog.com)

Datasheets for electronics components.