

DM74LS22

Dual 4-Input NAND Gate with Open-Collector Output

General Description

The 'LS22 contains two independent NAND gates, each with four data inputs.

Connection Diagram

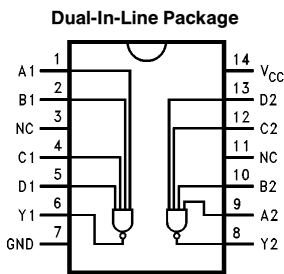

TL/F/10168-1

Order Number DM74LS22M or DM74LS22N
See NS Package Number M14A or N14A

Truth Table

$$Y = \overline{ABCD}$$

Inputs				Outputs
A	B	C	D	Y
X	X	X	L	H
X	X	L	X	H
X	L	X	X	H
L	X	X	X	H
H	H	H	H	L

H = High Logic Level
L = Low Logic Level
X = Either Low or High Logic Level

Absolute Maximum Ratings (Note)

Supply Voltage	7V
Input Voltage	7V
Operating Free Air Temperature Range	0°C to +70°C
DM74LS	
Storage Temperature Range	-65°C to +150°C

Note: The "Absolute Maximum Ratings" are those values beyond which the safety of the device cannot be guaranteed. The device should not be operated at these limits. The parametric values defined in the "Electrical Characteristics" table are not guaranteed at the absolute maximum ratings. The "Recommended Operating Conditions" table will define the conditions for actual device operation.

Recommended Operating Conditions

Symbol	Parameter	DM74LS22			Units
		Min	Nom	Max	
V _{CC}	Supply Voltage	4.75	5	5.25	V
V _{IH}	High Level Input Voltage	2			V
V _{IL}	Low Level Input Voltage			0.8	V
V _{OH}	High Level Output Voltage			5.5	mA
I _{OL}	Low Level Output Current			8	mA
T _A	Free Air Operating Temperature	0		70	°C

Electrical Characteristics over recommended operating free air temperature range unless otherwise noted

Symbol	Parameter	Conditions	Min	Typ (Note 1)	Max	Units
V _I	Input Clamp Voltage	V _{CC} = Min, I _I = -18 mA			-1.5	V
I _{CEX}	High Level Output Current	V _{CC} = Min, V _O = 5.5V, V _{IL} = Max			100	μA
V _{OL}	Low Level Output Voltage	V _{CC} = Min, I _{OL} = Max, V _{IH} = Min	DM74		0.5	V
		I _{OL} = 4 mA, V _{CC} = Min	DM74		0.4	
I _I	Input Current @ Max Input Voltage	V _{CC} = Max, V _I = 5.5V			0.1	mA
I _{IH}	High Level Input Current	V _{CC} = Max, V _I = 2.7V			20	μA
I _{IL}	Low Level Input Current	V _{CC} = Max, V _I = 0.4V			-0.4	mA
I _{CCH}	Supply Current Outputs High	V _{CC} = Max, V _{IN} = GND			0.8	mA
I _{CCL}	Supply Current Outputs Low	V _{CC} = Max, V _{IN} = Open			2.2	mA

Note 1: All typicals are at V_{CC} = 5V, T_A = 25°C.

Switching Characteristics

at $V_{CC} = +5.0V$, $T_A = +25^\circ C$

Symbol	Parameter	$R_L = 2\text{ k}\Omega$, $C_L = 15\text{ pF}$		Units
		Min	Max	
t_{PLH}	Propagation Delay Time Low to High Level Output		22	ns
t_{PHL}	Propagation Delay Time High to Low Level Output		24	ns

Physical Dimensions inches (millimeters)

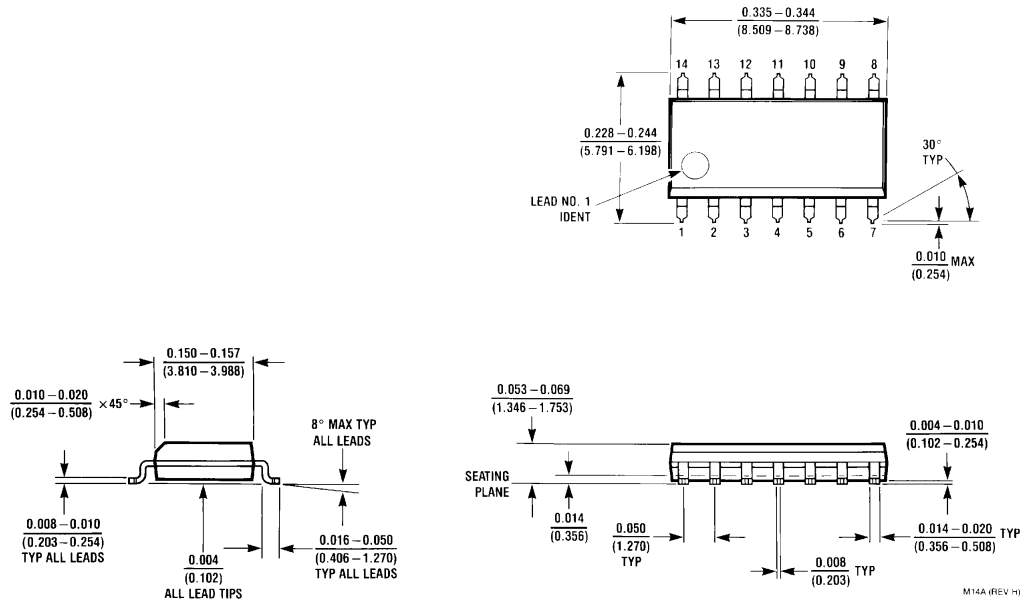

14-Lead Small Outline Molded Package (M)
Order Number DM74LS22M
NS Package Number M14A

Physical Dimensions inches (millimeters) (Continued)

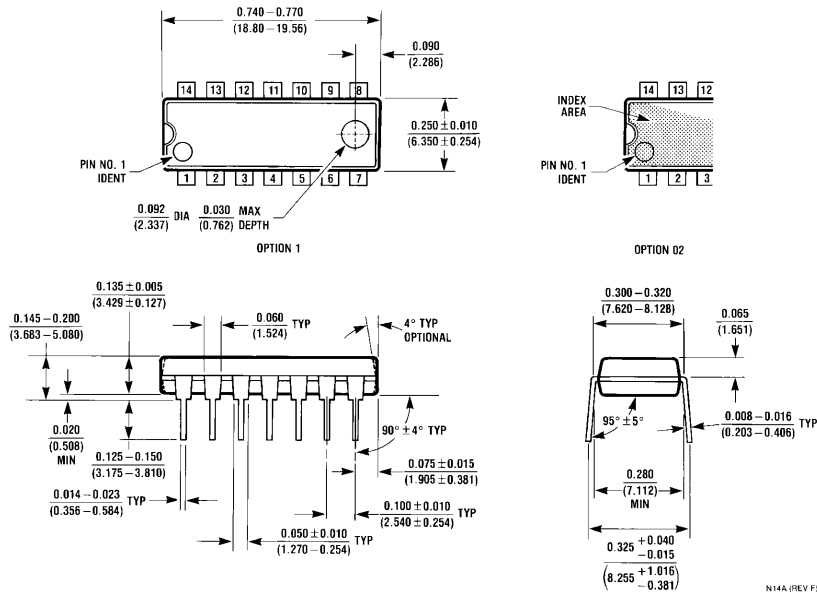

14-Lead Molded Dual-In-Line Package (N)
Order Number DM74LS22N
NS Package Number N14A

N14A (REV F)

LIFE SUPPORT POLICY

NATIONAL'S PRODUCTS ARE NOT AUTHORIZED FOR USE AS CRITICAL COMPONENTS IN LIFE SUPPORT DEVICES OR SYSTEMS WITHOUT THE EXPRESS WRITTEN APPROVAL OF THE PRESIDENT OF NATIONAL SEMICONDUCTOR CORPORATION. As used herein:

1. Life support devices or systems are devices or systems which, (a) are intended for surgical implant into the body, or (b) support or sustain life, and whose failure to perform, when properly used in accordance with instructions for use provided in the labeling, can be reasonably expected to result in a significant injury to the user.
2. A critical component is any component of a life support device or system whose failure to perform can be reasonably expected to cause the failure of the life support device or system, or to affect its safety or effectiveness.



National Semiconductor Corporation
 1111 West Bardin Road
 Arlington, TX 76017
 Tel: 1(800) 272-9959
 Fax: 1(800) 737-7018

National Semiconductor Europe
 Fax: (+49) 0-180-530 85 86
 Email: cnjwge@tevm2.nsc.com
 Deutsch Tel: (+49) 0-180-530 85 85
 English Tel: (+49) 0-180-532 78 32
 Français Tel: (+49) 0-180-532 93 58
 Italiano Tel: (+49) 0-180-534 16 80

National Semiconductor Hong Kong Ltd.
 19th Floor, Straight Block,
 Ocean Centre, 5 Canton Rd.
 Tsimshatsui, Kowloon
 Hong Kong
 Tel: (852) 2737-1600
 Fax: (852) 2736-9960

National Semiconductor Japan Ltd.
 Tel: 81-043-299-2309
 Fax: 81-043-299-2408

National does not assume any responsibility for use of any circuitry described, no circuit patent licenses are implied and National reserves the right at any time without notice to change said circuitry and specifications.

This datasheet has been download from:

www.datasheetcatalog.com

Datasheets for electronics components.