

Surface Miner 4200 SM

Technical specification

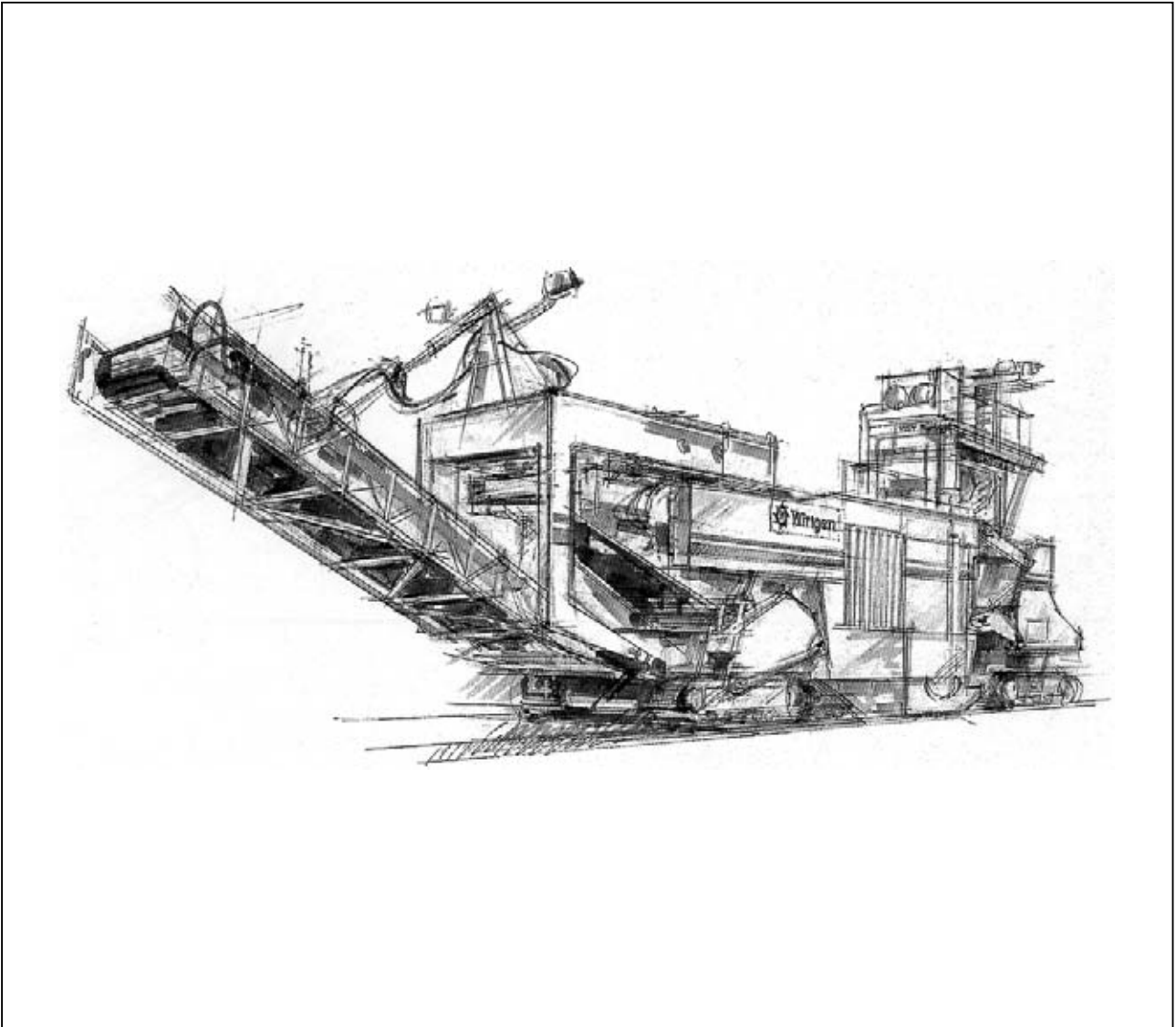

Surface Miner 4200 SM

For cutting coal and soft to medium-hard (<70 MPa) rock

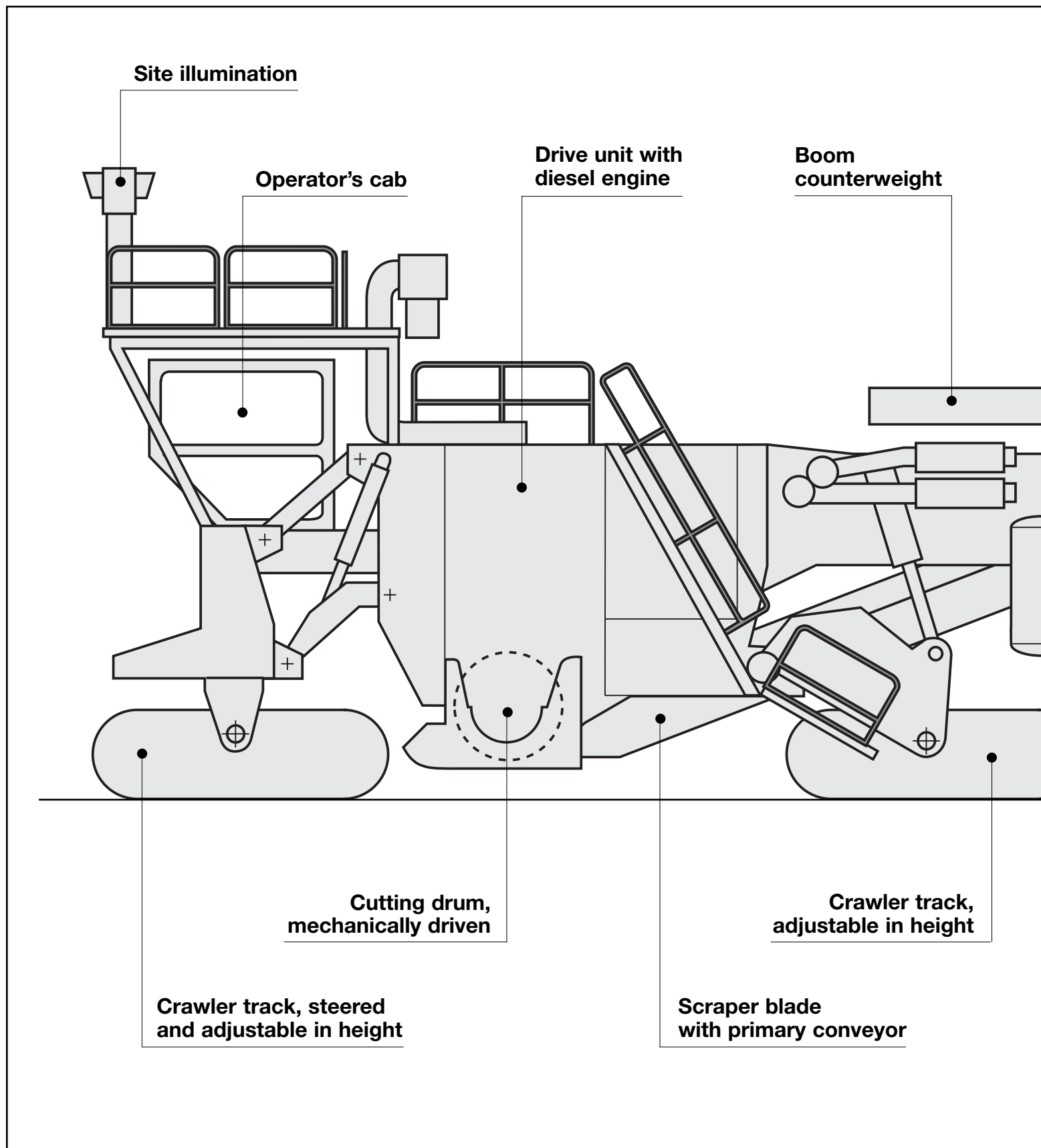

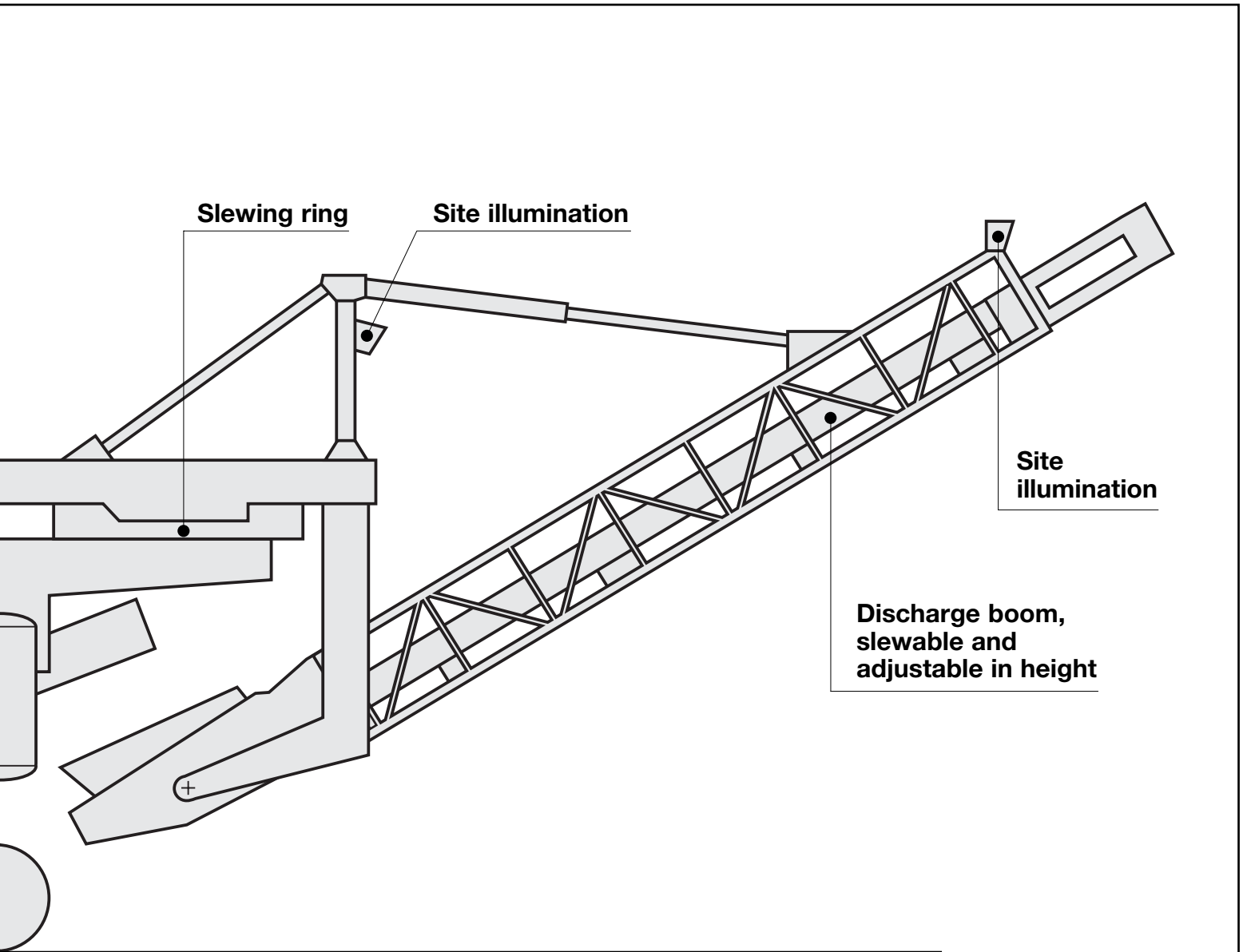

Technical specification

Surface Miner 4200 SM		
Cutting drum		
Cutting width max.	mm	4.200
Cutting depth* ¹	mm	0 – 800
Cutting drum diameter with tools	mm	1.860
Number of cutting tools on drum		Depending on machine application
Engine		
Make		Cummins
Type		KTA 50
Cooling		Water
Number of cylinders		16
Output	kW/HP/PS	1.194/1.600/1.623
Fuel consumption, 1/1 load	l/h	284
Fuel consumption, 2/3 load	l/h	189
Speed / Gradeability		
Operating speed	m/min	0 – 20
Travel speed	km/h	0 – 2,5
Gradeability	%	20
Max. transverse gradient	%	8
Weights *²		
Front axle load, full tanks	daN (kg)	73.600
Rear axle load, full tanks	daN (kg)	117.800
Own weight	daN (kg)	172.400
Operating weight, full tanks	daN (kg)	191.400
Crawler tracks		
Front crawlers (L x W x H)	mm	3.880 x 500 x 1.200
Rear crawlers (L x W x H)	mm	3.880 x 700 x 1.200
Tank capacities		
Fuel tank	l	2.900
Hydraulic fluid tank	l	800
Water tank	l	15.000
Electrical system		
Control	V	24
Lighting	V	220
Spotlights		10 à 400 W
Conveyor system		
Width of primary belt	mm	1.800
Length of primary belt	mm	7.000
Width of discharge belt	mm	1.800
Length of discharge belt	mm	15.000
Theoretical discharge belt capacity	m ³ /h	2.400

*¹ = The maximum cutting depth may deviate from the value indicated, due to tolerances and wear.

*² = All weights refer to basic machine without any additional equipment.

Dimensions in mm

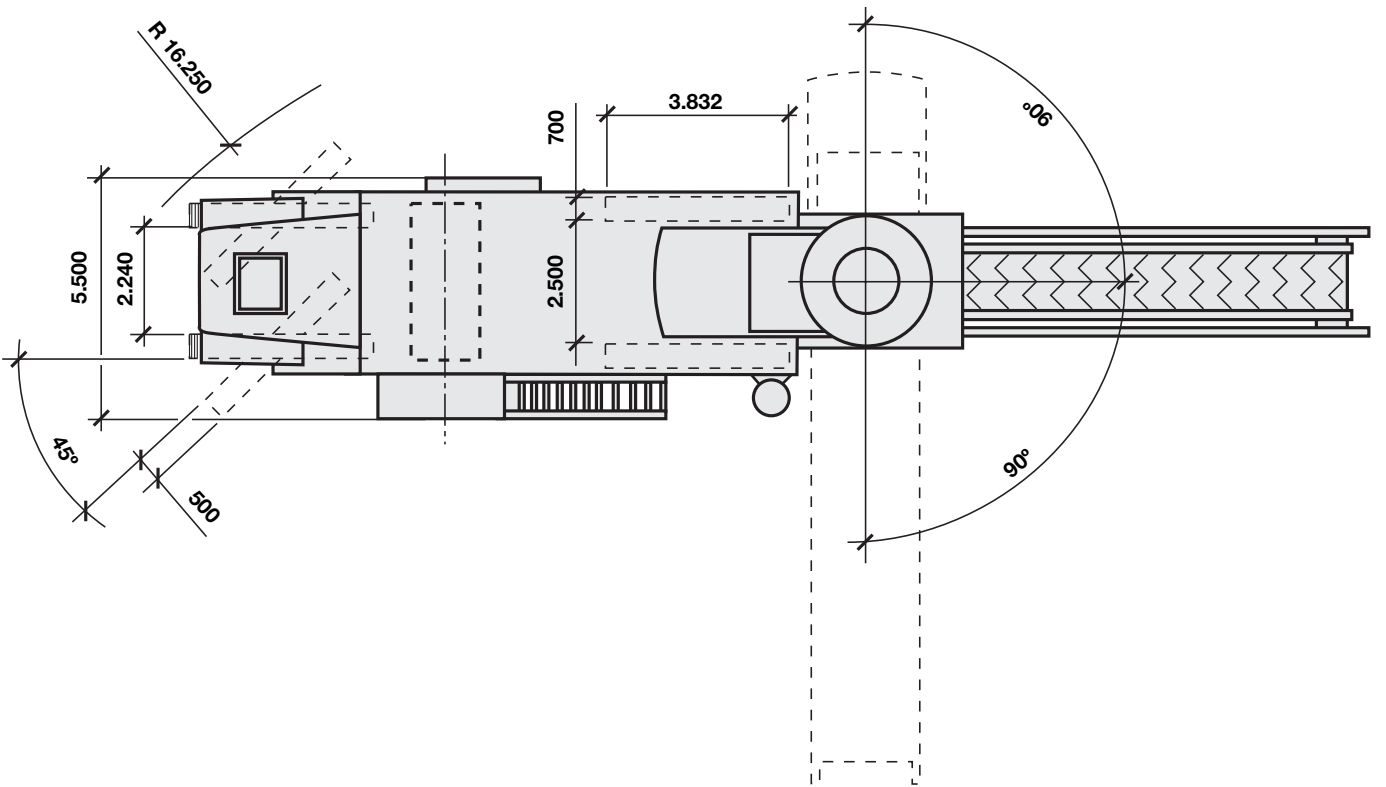
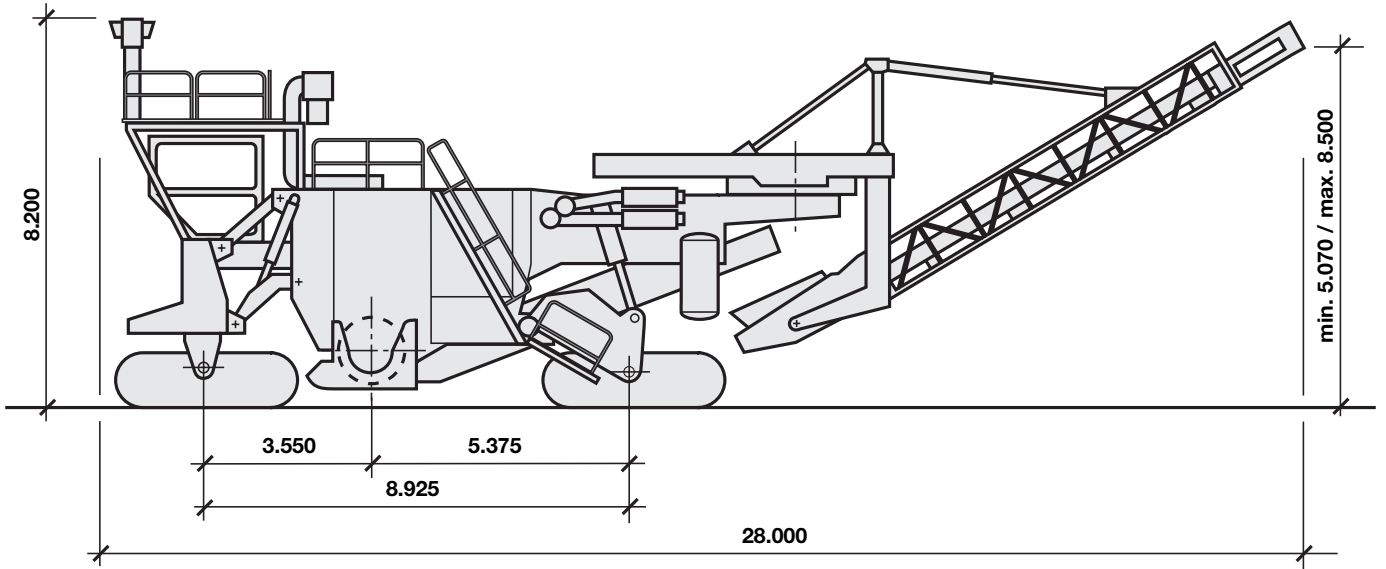

Technical description

Basic design

Surface Miner for cutting coal and soft to medium-hard (<70 MPa) rock with mechanically driven cutting drum and two-part loading conveyor.

Frame

Rigid, welded honeycomb design with integrated tanks for diesel, hydraulic fluid and water.

Crawler unit suspension

The four crawler tracks are free-floating and connected to supporting arms which are linked to the frame via a moving parallelogram made up to two strut constructions in each case. The tracks are fitted with double grouser track shoes.

Cutting depth control

The height is adjusted via hydraulic cylinders. The rear crawler suspensions are controlled via an automatic cutting depth control unit.

Travel drive

Each crawler unit is driven by a planetary gearing with hydraulic motor. Each of the front and rear travel drive motors is fed by a hydraulic variable displacement pump. The advance speed can be infinitely adjusted from zero to maximum in both travel gear and operating gear.

Brake system

Operating brake via a closed-loop hydrostatic system. Parking brake for each crawler unit with spring-loaded multiple disc brakes.

Steering

The machine is steered via two hydraulic cylinders on each of the front crawler tracks.

Cutting drum

The cutting drum rotates in an up-cutting direction. The cutting tools are mounted in toolholders welded onto the body of the drum. The tools used depend on the machine's momentary use and on the properties of the material being cut.

Cutting drum drive

The cutting drum is driven via a mechanical clutch on the flywheel side of

the diesel engine, as well as transmission belts and a planetary gearing installed in the cutting drum. The cutting speed can be adjusted in line with the momentary application by replacing the pulleys for the transmission belts.

Scraper blade

The drum chamber is sealed by a hydraulically actuated scraper blade behind the cutting drum, thus ensuring a clean cutting surface.

Water spraying system

The water spraying system largely prevents the generation of dust while cutting material and reduces the degree of wear on the cutting tools. The spray nozzles can easily be removed for cleaning. Spray nozzles are additionally installed for the loading conveyors.

Soundproofing

The engine, cooling unit and hydraulic system are soundproofed to reduce the noise level and protect both the operator and the environment.

Operator's cab

Enclosed cab, soundproofed and mounted on vibration-damping elements. Rotating driver's seat with armrests into which all the most important controls have been integrated. The cab is equipped with air-conditioning and heating.

Conveyor system

The conveyor system comprises a wide primary belt which picks up the cut and comminuted material at the cutting drum, as well as loading conveyor to discharge the material onto trucks. The loading conveyor can be adjusted in height and slewed to both sides. The conveyor speed can be varied.

Lighting system

Complete lighting system with generator and halogen spotlights for nighttime operations.

Safety equipment

Comprehensive safety equipment with five Emergency OFF switches.

Pneumatic system

Compressor and accumulators for starting the diesel engine, as well as auxiliary functions.

Tool kit

Complete tool kit for maintenance and repairs.

Central lubrication

The Surface Miner is equipped with a central lubrication system which supplies all the most important bearing points with grease.

Optional equipment	4200 SM
Cold starting facility	●
Additional diesel tank (800 litres)	●
Cab heating independently of the diesel engine	●
Cutting depth control with laser sensor	●
Cutting depth control with sensor wire	●
Cutting depth control with multiplex unit	●
Cutting depth control with non-contacting triple sensor for surfaces which have not been finely graded	●
Radio	●
Water filling pump (hydraulically driven)	●
Extended tool kit	●
Service package	●

Surface Miner 4200 SM

Disassembly for transport

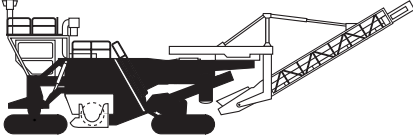
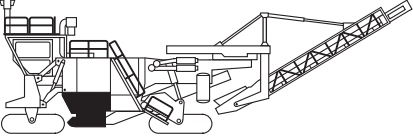
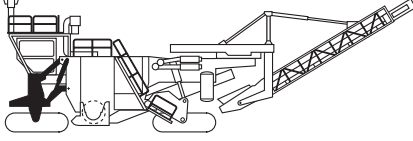
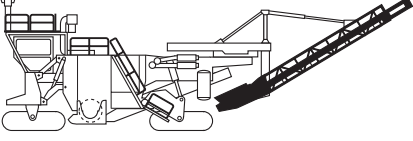
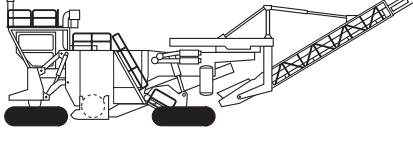
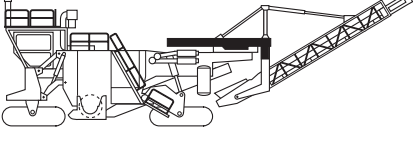
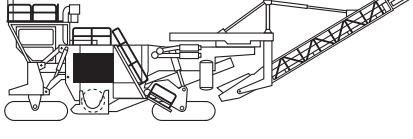
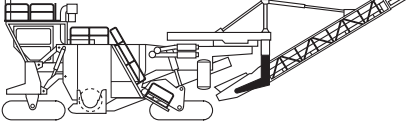
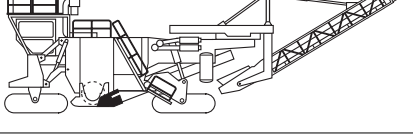
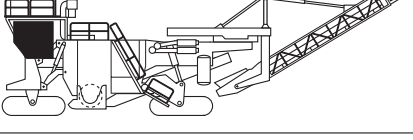
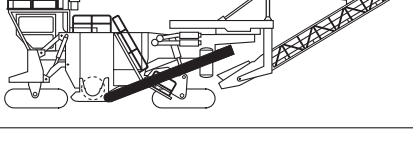
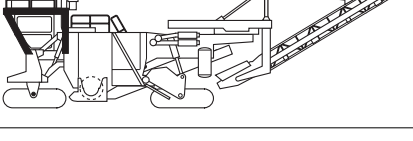
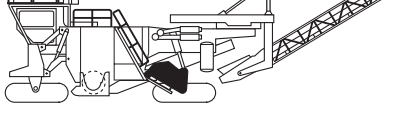
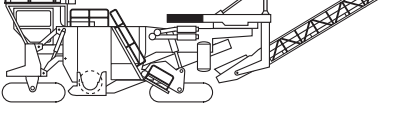
<p>1 Frame</p> 	<p>Dimensions L x W x H 15,70 x 5,50 x 4,00 m</p> <p>Unit weight 101.500 kg</p> <p>Overall weight One part = 101.500 kg</p>	<p>2 Drum unit</p> 	<p>Dimensions L x W x H 2,90 x 5,50 x 2,25 m</p> <p>Unit weight 30.000 kg</p> <p>Overall weight One part = 30.000 kg</p>
<p>1.1 Front crawler brackets</p> 	<p>Dimensions L x W x H 2,40 x 1,20 x 3,10 m</p> <p>Unit weight 6.200 kg</p> <p>Overall weight Two parts = 12.400 kg</p>	<p>3 Discharge boom</p> 	<p>Dimensions L x W x H 16,80 x 2,50 x 1,95 m</p> <p>Unit weight 9.500 kg</p> <p>Overall weight One part = 9.500 kg</p>
<p>1.2 Crawler tracks</p> 	<p>Dimensions L x W x H 3,80 x 0,90 x 1,20 m</p> <p>Unit weight 6.500 kg</p> <p>Overall weight Four parts = 26.000 kg</p>	<p>4 Belt suspension, top</p> 	<p>Dimensions L x W x H 5,00 x 3,00 x 2,00 m</p> <p>Unit weight 6.700 kg</p> <p>Overall weight One part = 6.700 kg</p>
<p>1.3 Drive station</p> 	<p>Dimensions L x W x H 2,60 x 4,90 x 2,25 m</p> <p>Unit weight 13.000 kg</p> <p>Gesamtgewicht One part = 13.000 kg</p>	<p>5 Belt suspension, bottom</p> 	<p>Dimensions L x W x H 3,20 x 1,60 x 0,33 m</p> <p>Unit weight 550 kg</p> <p>Overall weight Two parts = 1.100 kg</p>
<p>1.4 Scraper blade</p> 	<p>Dimensions L x W x H 4,30 x 2,20 x 1,00 m</p> <p>Unit weight 2.000 kg</p> <p>Overall weight One part = 2.000 kg</p>	<p>6 Operator's cab</p> 	<p>Dimensions L x W x H 2,72 x 2,30 x 3,05 m</p> <p>Unit weight 2.000 kg</p> <p>Overall weight One part = 2.000 kg</p>
<p>1.5 Primary conveyor</p> 	<p>Dimensions L x W x H 9,00 x 2,50 x 1,30 m</p> <p>Unit weight 5.500 kg</p> <p>Overall weight One part = 5.500 kg</p>	<p>7 Protective canopy for cab</p> 	<p>Dimensions L x W x H 3,90 x 2,80 x 0,80 m</p> <p>Unit weight 1.800 kg</p> <p>Overall weight One part = 1.800 kg</p>
<p>1.6 Rear crawler brackets</p> 	<p>Dimensions L x W x H 2,75 x 1,50 x 0,85 m</p> <p>Unit weight 4.000 kg</p> <p>Overall weight Two parts = 8.000 kg</p>	<p>8 Counterweight</p> 	<p>Dimensions L x W x H 3,50 x 3,00 x 0,80 m</p> <p>Unit weight 15.900 kg</p> <p>Overall weight One part = 15.900 kg</p>

Plus miscellaneous wooden crates containing: railings, buffers, air filters, steps, lamps, etc. Total weight approx. 5,000 kg



Wirtgen GmbH · Hohner Strasse 2
53578 Windhagen · Germany

Phone: +49 (0) 26 45 / 131-0

Fax: +49 (0) 26 45 / 131-242

Internet: www.wirtgen.de
