

LAMAC

Light Aircraft Manufacturers Association of Canada

DESIGN STANDARDS  
FOR ADVANCED  
ULTRA-LIGHT  
AEROPLANES

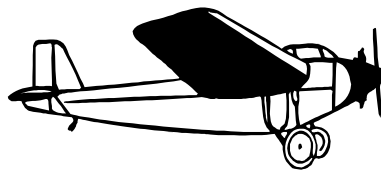

880 St-Fereol,  
Les Cedres, Qc. J7T 2X8  
Canada.  
Tel: (450) 452-4772





# PREAMBLE

## REVISED EDITION

**Effective: May 30, 2001**

### **General**

The contents of this publication are based on the Light Plane Airworthiness Standards (LPAS), as revised by the Light Aircraft Manufacturers Association of Canada (LAMAC) and presented to Transport Canada as "Guideline for Ultralight Aircraft Airworthiness", Issue 2, February 1988.

These standards have been accepted by Transport Canada for the design of Advanced Ultra-light Aeroplanes.

### **Format**

To make this publication user-friendly, the content has been reorganized to parallel the presentation of subject material of Chapter 523 of the Airworthiness Manual (and Part 23 of the Federal Aviation Regulations of the United States of America).

The section titles and numbering agree with complementary sections of Chapter 523 (Part 23); some figures and tables have been reproduced from Chapter 523 (e.g., TP10141, sect. 303 = Chapter 523, section 523.303 = FAR Part 23, 23.303)

INTENTIONALLY LEFT BLANK

## Table of Contents

### RECORDS OF AMENDMENTS ii

### PREAMBLE iv

*General iv*

*Format iv*

### ABBREVIATIONS AND DEFINITIONS ix

#### Chapter A - General 1

1. Applicability 1
2. Advanced Ultra-Light Aeroplane Category 1
3. Minimum Useful Load 1
4. Maximum Empty Mass (Weight) 1

#### Chapter B - Flight 2

5. Proof of Compliance 2
6. Load Distribution Limits 2
7. Propeller Speed and Pitch Limits 2
8. Performance, General 2
9. Stalling Speeds 2
10. Take-off 2
11. Climb: All engines Operating 3
12. Landing 3
13. Balked Landing 3
14. Controllability and Manoeuvrability 3
15. Longitudinal Control 4
16. Directional and Lateral Control 4
17. Static Longitudinal Stability 4
18. Static Directional and Lateral Stability 4
19. Dynamic Stability 4
20. Wings Level Stall 4
21. Turning Flight and Accelerated Stalls 4
22. Directional Stability and Control 5

#### Chapter C - Structure 6

23. Loads 6
24. Factor of Safety 6
25. Strength and Deformation 6
26. Proof of Structure 6
27. Flight Loads 7
28. Flight Envelope 7
29. Design Airspeeds (in mph) 8
30. Limit Load Factors 8
31. Symmetrical Wing Loads 9
32. Unsymmetrical Wing Loads 10
33. Rear Fuselage Loads 10
34. Forward Fuselage Loads 11
35. Control Surface Loads 11
36. Ground Gust Conditions 11
37. Control System and Supporting Structure 12
38. Ground Load Conditions 12
39. Side Load Conditions 14
40. Braked Roll Conditions 14
41. Supplementary Conditions for Tail Wheel 15

42. Supplementary Conditions for Nose Wheel 15
43. Water Load Conditions 16
44. Emergency Landing Conditions 16
45. Tie-down Points 16

#### **Chapter D - Design and Construction 17**

46. General 17
47. Materials and Workmanship 17
48. Fabrication Methods 17
49. Self-Locking Nuts 17
50. Protection of Structure 17
51. Accessibility 17
52. Flutter 17
53. Proof of Strength - Wings 17
54. Control System - Operation Test 18
55. Pilot Compartment 18

#### **Chapter E - Powerplant 19**

56. Installation 19
57. Engines 19
58. Fuel Tank Tests 19
59. Fuel Tank Vents 19
60. Fuel Strainer or Filter 19
61. Induction System Icing Protection 19

#### **Chapter F - Equipment 21**

62. Flight and Navigation Instruments 21
63. Powerplant Instruments 21
64. Miscellaneous Equipment 21
65. Safety Belts and Harnesses 21

#### **Chapter G - Operating Limitations and Information 23**

66. General 23
67. Weight and Centre of Gravity 23
68. Powerplant Limitations 23
69. Instructions for Continued Airworthiness 23
70. Control Markings 23
71. Miscellaneous Markings and Placards 23
72. Aeroplane Manual 23
73. Operating Limitations 23
74. Operating Procedures 23

#### **APPENDIX A 26**

75. CONTROL SURFACE LOADINGS (Refer to sections 33 and 35) 26

#### **APPENDIX B 28**

76. BASIC LANDING CONDITIONS 28

#### **APPENDIX B 29**

- BASIC LANDING CONDITIONS 29

INTENTIONALLY LEFT BLANK

## ABBREVIATIONS AND DEFINITIONS

The abbreviations and definitions presented here are for use with this publication. A complete list is presented in Chapter 501 of the Airworthiness Manual.

$$AR = \text{aspect ratio} = \frac{b}{MAC} = \frac{b^2}{S}$$

b = wing span m (ft.)

c = chord m (ft.)

CAS = calibrated air speed

$C_L$  = lift coefficient

$C_D$  = drag coefficient

CG = centre of gravity

$C_m$  = moment coefficient ( $C_m$  is with respect to C/4 point, positive = nose up)

$C_n$  = normal coefficient

daN = decaNewton

deg. = degrees =  $2 \times 3.1416/360 = .0174$  radian =  $1 = 1/57.3$  per radian

g = acceleration due to gravity =  $9.81 \text{ m/s}^2$  ( $32.2 \text{ ft/s}^2$ )

IAS = indicated air speed

MAC = Mean Aerodynamic Chord

$M(W)$  = gross (maximum design) mass (weight) kgs (lbs)

$m(w)$  = average design surface load  $\text{kgs/m}^2$  (PSF)

n = load factor

$$q = \rho \times \frac{V^2}{2} = \frac{V^2}{1.632} \quad (q = \text{KPa and } V = \text{m/s})$$

$$\left( = \frac{V^2}{391} \quad (q = \text{lb/in}^2 \text{ and } V = \text{mph}) \right)$$

S = wing area in square meters (square ft.)

$V_A$  = design manoeuvring speed

$V_C$  = design cruising speed

$V_D$  = design diving speed

$V_F$  = design flap speed

$V_H$  = maximum speed in level flight with maximum continuous power

$V_{NE}$  = never-exceed speed

$V_S$  = stalling speed or minimum steady flight speed at which the aeroplane is controllable

$V_{S0}$  = stalling speed or minimum steady flight speed in the landing configuration

$V_{SP}$  = maximum spoiler/speed brake extended speed

$V_{S1}$  = stalling speed or minimum steady flight speed obtained in a specific configuration

$V_X$  = speed for best angle of climb

$V_Y$  = speed for best rate of climb

## Chapter A - General

### 1. Applicability

- (a) This publication contains standards for the design of Advanced Ultra-Light Aeroplanes.
- (b) Each person who manufactures an aeroplane or aeroplane kit for subsequent registration in the advanced ultra-light category shall demonstrate compliance with the applicable requirements of this publication.

### 2. Advanced Ultra-Light Aeroplane Category

An Advanced Ultra-Light Aeroplane is an aeroplane which:

- (a) Is propeller driven;
- (b) Is designed to carry a maximum of two persons, including the pilot;
- (c) Has a maximum take-off mass,  $M_{TOMax}$ , (weight,  $W_{TOMax}$ ) of:
  - (i) 350 Kg (770 lb) for a single place aeroplane, or
  - (ii) 560.0 Kg ( 1232 lb) for a two place aeroplane;
- (d) A maximum stalling speed in the landing configuration,  $V_{SO}$ , at manufacturer's recommended maximum take-off mass (weight) not exceeding 72 km/h (45 mph) (IAS); and
- (e) Is limited to non-aerobatic operations. Non-aerobatic operations include:
  - (1) manoeuvres incident to normal flying
  - (2) stalls and spins (if approved for type);
  - (3) lazy eights, chandelles; and
  - (4) steep turns, in which the angle of bank is not more than 60°

### 3. Minimum Useful Load

Advanced ultra-light aeroplanes shall have a Minimum Useful Load,  $M_U$  ( $W_U$ ) computed as follows:

- (a) For a single place aeroplane:
  - $M_U = 80 + 0.3P$ , in kg; where P is the rated engine(s) power in kw;
  - $(W_U = 175 + 0.5P)$ , in lb; where P is the rated engine(s) power in BHP).
- (b) For a two place aeroplane:
  - $M_U = 160 + 0.3P$ , in kg; where P is the rated engine(s) power in kw;
  - $(W_U = 350 + 0.5P)$ , in lb; where P is the rated engine(s) power in BHP).

### 4. Maximum Empty Mass (Weight)

The Maximum Empty Mass,  $M_{Emax}$ , (Weight,  $W_{Emax}$ ) includes all operational equipment that is actually installed in the aeroplane. It includes the mass (weight) of the airframe, powerplant, required equipment, optional and specific equipment, fixed ballast, full engine coolant, hydraulic fluid, and the residual fuel and oil.

Hence, the maximum empty mass (weight) = maximum take-off mass (weight) - minimum useful load.

## Chapter B - Flight

### 5. Proof of Compliance

Each of the following requirements shall be met at the most critical mass (weight) and CG configuration. Unless otherwise specified, the speed range from stall to  $V_{NE}$  shall be considered.

### 6. Load Distribution Limits

(a) Using comprehensive references, the following shall be determined:

- (1) the maximum empty mass (weight) and maximum take-off mass (weight) as defined in section 5. and 7., and a minimum flying weight; and
- (2) the empty CG, most forward and most rearward CG.

Note: Standard occupant mass (weight) = 80 kg (175 lbs);  
Fuel density = .72 kg/l (6 lb/US gal.)

(b) Fixed and/or removable ballast may be used if properly installed and placarded.

### 7. Propeller Speed and Pitch Limits

Propeller speed (RPM) and pitch shall not be allowed to exceed safe operating limits established by the manufacturer under normal conditions (i.e. maximum take-off RPM during take-off and 110% of maximum continuous RPM at closed throttle and  $V_{NE}$ ).

### 8. Performance, General

All performance requirements apply in standard ICAO atmosphere and still air conditions. Speeds shall be given in indicated (IAS) and calibrated (CAS) airspeeds.

### 9. Stalling Speeds

(a) Wing level stalling speeds shall be determined by flight test at a rate of speed decrease of 1.6 km/h/sec (1 mph/sec) or less, throttle closed, with maximum weight, and most unfavourable CG:

- (1)  $V_{S0}$ : shall not exceed 72 km/h (45mph)
- (2)  $V_{S1}$ : flaps retracted, shall not exceed 96.5 km/h (60 mph).

(b) Level wing attitude and yaw control shall be possible down to  $V_{S0}$  or the speed at which the pitch control reaches the control stop.

### 10. Take-off

With take-off at the maximum weight, full throttle, sea level, the following shall be measured:

- (a) Ground roll distance; and,
- (b) Distance to clear a 15.2 m (50 ft.) obstacle at  $1.3 V_{S1}$ .

Note: The aeroplane configuration, including flap position, shall be specified.

## 11. Climb: All engines Operating

With climb out at full throttle:

- (a) Best rate of climb ( $V_y$ ) shall exceed 93 m (300 ft) per minute; and,
- (b) Best angle of climb ( $V_x$ ) shall exceed 1/12.

## 12. Landing

For landing with throttle closed and flaps extended, the following shall be determined:

- (a) Landing distance from 15.2 m (50 ft.)  $1.3 V_{SO}$ ; and
- (b) Ground roll distance with reasonable braking if so equipped.

## 13. Balked Landing

For a balked landing at  $1.3 V_{SO}$  and flaps extended, the full throttle angle of climb shall exceed 1/30.

## 14. Controllability and Manoeuvrability

- (a) The aeroplane shall be safely controllable and manoeuvrable during take-off, climb, level flight (cruise), dive, approach and landing (power off and on, flaps retracted and extended) through the use of primary controls and normal displacements for the aircraft type.
- (b) Smooth transition between all flight conditions shall be possible without excessive pilot skills nor exceeding pilot force as shown in Figure 1.

Values in decaNewtons (pounds) of force as applied to the control wheel or rudder pedals	Pitch daN (lb)	Roll daN (lb)	Yaw daN (lb)
(1) For temporary application:			
Stick .....	26.7 (60)	13.3 (30)	.....
Wheel (applied to rim)....	26.7 (60)	13.3 (30)	.....
Rudder pedal .....	.....	.....	59.2(130)
(2) For prolonged application:			
	4.4 (10)	2.2 (5)	8.9 (20)

Figure 1

- (c) It shall be possible to trim the aeroplane at least for level cruise at an average weight and CG.

## 15. Longitudinal Control

Longitudinal control shall allow:

- (a) Speed increase from  $1.1 V_{S1}$  to  $1.5 V_{S1}$  and from  $1.1 V_{S0}$  to  $V_F$  in less than 3 seconds. This applies for both power-off and full power conditions.
- (b) Full control to be maintained when retracting and extending the flaps in the normal speed range; and
- (c) Stick forces per 'g' to steadily increase.

## 16. Directional and Lateral Control

- (a) Reversing the roll from 30 degrees one wing low over to 30 degrees the other wing low shall be possible within 4 seconds at  $1.3 V_{S0}$  (flaps extended and throttle idle) and at  $1.2 V_{S1}$  (flaps retracted, throttle idle and full).
- (b) Rapid entry and recovery into/from yaw and roll shall not result in uncontrollable flight characteristics.
- (c) Where aircraft is so equipped, aileron and rudder forces shall not reverse with increased deflection.

## 17. Static Longitudinal Stability

Longitudinal stability shall be positive from  $1.2 V_{S1}$  to  $V_{NE}$  at the most critical power setting and CG combination.

## 18. Static Directional and Lateral Stability

- (a) Directional and lateral stability and take-off and climb performance tests shall be performed to ensure the aeroplane complies with the requirements of this publication.
- (b) Directional and lateral stability is considered acceptable when the spiral stability of the aeroplane is neutral within the range specified in section 17.

## 19. Dynamic Stability

Any short period oscillation shall be rapidly dampened with the controls free and the controls fixed.

## 20. Wings Level Stall

It shall be possible to prevent more than 15 degrees of roll or yaw by normal use of the controls.

## 21. Turning Flight and Accelerated Stalls

Stalls shall also be performed with power. After establishing a 30 degree co-ordinated turn, the turn shall be tightened until the stall. After the turning stall, level flight shall be regained without exceeding 60 degrees of roll. These stalls shall be performed with power on, flaps retracted and flaps extended. No excessive loss of altitude, nor spin tendency, nor speed build up shall be associated with the recovery.

**22. Directional Stability and Control**

- (a) Steering: Normal control inputs will achieve the desired steering results. In the case of aircraft equipped with rudders, pushing the right rudder pedal shall cause a turn to the right.
- (b) Ground handling shall not require special skills. No uncontrollable ground-looping tendency shall arise from 90 degrees of cross wind up to the maximum wind velocity selected by the applicant.

## Chapter C - Structure

### 23. Loads

- (a) All requirements are specified in terms of limit loads.
- (b) Ultimate loads are limit loads multiplied by the factor of safety of section 24
- (c) Loads shall be redistributed if the deformations affect them significantly.

### 24. Factor of Safety

- (a) The factor of safety is 1.5, except that it shall be increased to:
  - (1)  $2.0 \times 1.5 = 3.$  on castings;
  - (2)  $1.2 \times 1.5 = 1.8$  on fittings;
  - (3)  $4.45 \times 1.5 = 6.67$  on control surface hinges;
  - (4)  $2.2 \times 1.5 = 3.3$  on push-pull control systems; and
  - (5)  $1.33 \times 1.5 = 2.$  on cable control systems.
- (b) The structure shall be designed as far as practicable, to avoid points of stress concentration where variable stresses above the fatigue limit are likely to occur in normal service.

### 25. Strength and Deformation

- (a) Limit loads shall not create permanent deformations nor large enough deformations which may interfere with safe operation.
- (b) The structure shall be able to support ultimate loads with a positive margin of safety (analysis), or without failure for at least three seconds (static tests).

### 26. Proof of Structure

Each critical load requirement shall be investigated either by conservative analysis or tests or a combination of both.

**27. Flight Loads**

- (a) Appendix A of Chapter 523 of the Airworthiness Manual shall be used to determine the flight loads, except as noted in paragraphs 27(b) and (c).
- (b) Other design criteria may be used to determine the flight loads if their interpretation gives a level of safety equal to or exceeding Chapter 523 of the Airworthiness Manual.
- (c) For conventional designs, the simplified criteria of sections 28. to 34. may be used if they do not result in smaller load factors than the gust load factors of paragraph 27.(a), or in unrealistic values and the design falls within the limitations of Figure 2.

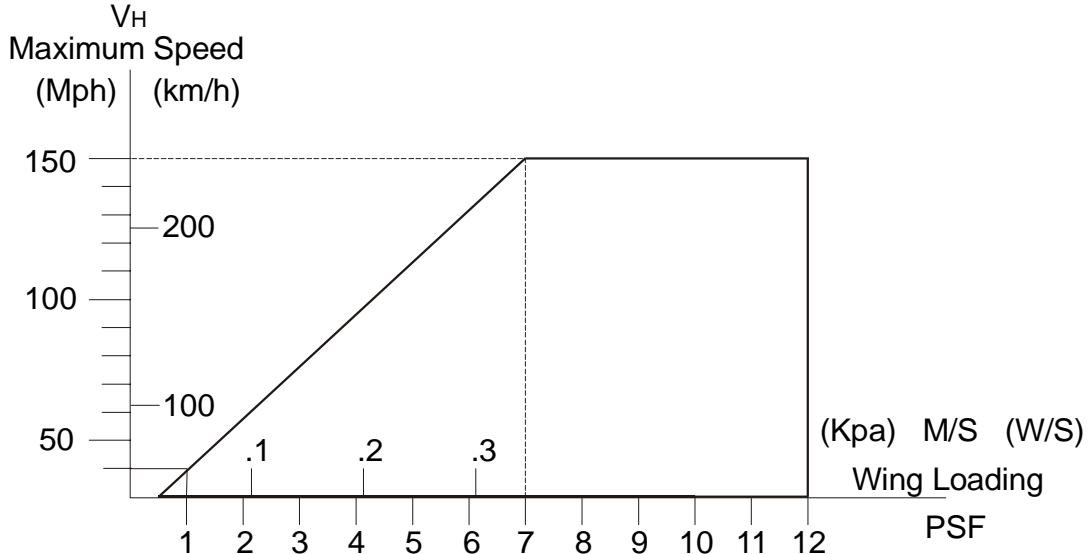

Figure 2

**28. Flight Envelope**

For conventional designs referred to in paragraph 27.(c), compliance shall be shown at the combinations of airspeed and load factor on the boundaries of the flight envelopes at Figure 3 as specified in section 31. The flight envelope represents the envelope of the flight loading conditions specified by the criteria of sections 29. and 30.

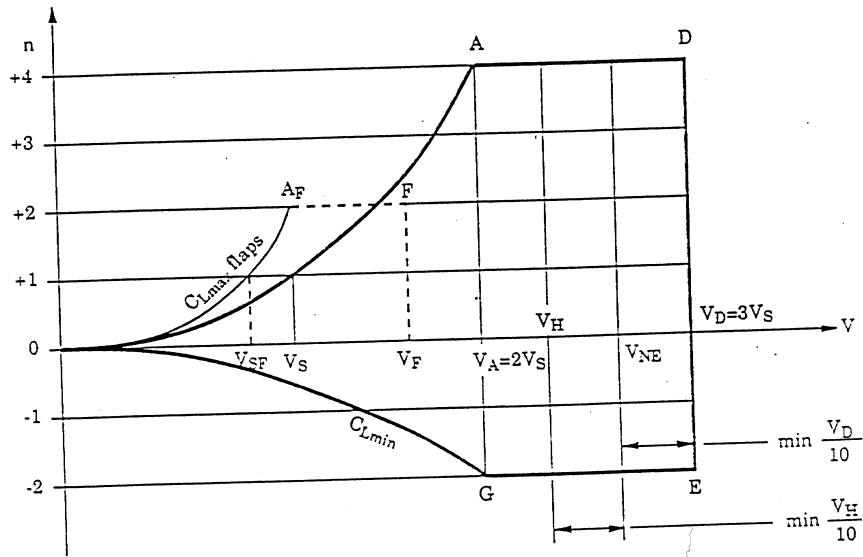

Figure 3 - Flight Envelope

## 29. Design Airspeeds (in mph)

- (1) Design Stall Speed:

$$V_S = 19.77 x \sqrt{\frac{W}{S x C_{Lmax}}}$$

(The following values may be used:  $C_{Lmax} = 1.35$  and  $C_{Lmin} = -0.68$ )

- (2) Design Manoeuvring Speed:

$$V_A = 19.77 x \sqrt{\frac{n x W}{S x C_{Lmax}}} = 2 x V_S$$

- (3) Design Dive Speed,  $V_D$  is the greater of the following:

$$V_D = 1.5 x V_A = 3 x V_S, \text{ or}$$

$$V_D = 1.22 V_H$$

- (4) Never Exceed Speed:

$V_{NE}$  shall be less than  $.9 x V_D$ , and more than  $1.1 V_H$

- (5) Flap Extended Speed

$$V_F = 19.77 x \sqrt{\frac{W}{S x C_{Lmax flap}}}$$

$V_F$  shall be more than  $\sqrt{2} x V_S = 1.42 x V_S$

## 30. Limit Load Factors

The limit load factors shall be:

- (a) Positive:  $n = 4$  (flaps retracted) and  $n = 2$  (flaps extended); and  
 (b) Negative:  $n = -2$  (flaps retracted) and  $n = 0$  (flaps extended).

### 31. Symmetrical Wing Loads

As a minimum, the following three conditions need investigation:

- |             |                      |            |
|-------------|----------------------|------------|
| (a) Point A | normal load up       | = 4 x W    |
|             | tangential forward   | = W        |
| (b) Point G | normal down          | = -2 x W   |
|             | tangential forward   | = -2 x W/5 |
| (c) Point F | with flaps extended: |            |
|             | normal up            | = 2 x W    |
|             | tangential forward   | = W        |

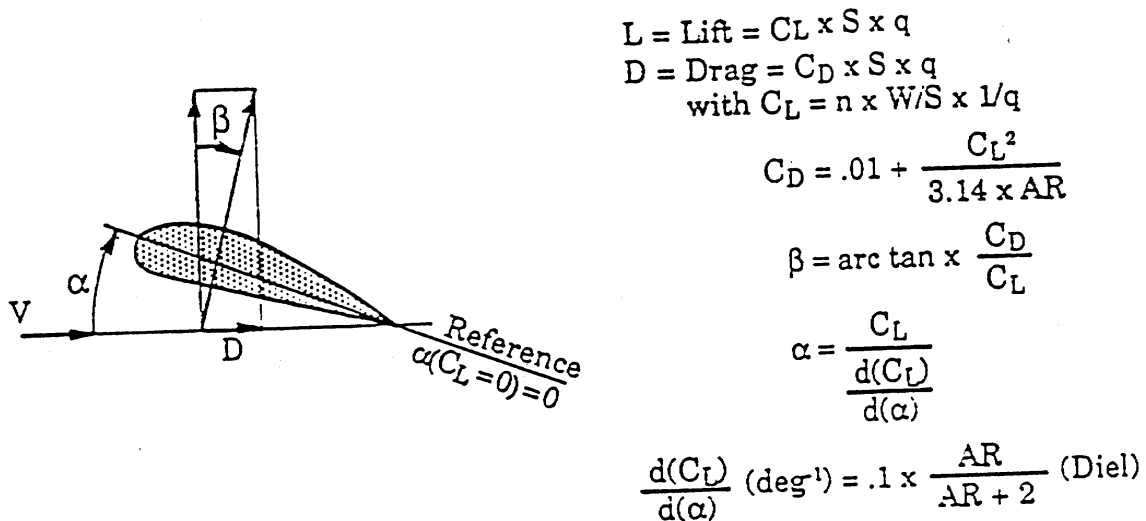

Figure 4

- Note:
- (1) Both components (normal and tangential) must be considered simultaneously.
  - (2) The aerodynamic loads shall be considered to be located at the aerodynamic centre.
  - (3) The wing normal and tangential loads given by the assumptions of Figure 4 are balanced by the inertia loads (corresponding load factors).
  - (4) If wing flaps are installed, the resulting loads shall also be investigated at point F of figure 3. This a symmetrical load condition.

### 32. Unsymmetrical Wing Loads

- (a) Shear, Wing carry-through: Assume 100% of Point A on one wing, and apply 75% of Point A on the other wing.
- (b) Torsion, Wing: Assume 75% of Point A or D on each wing and add the torsional loads due to the aileron deflection.

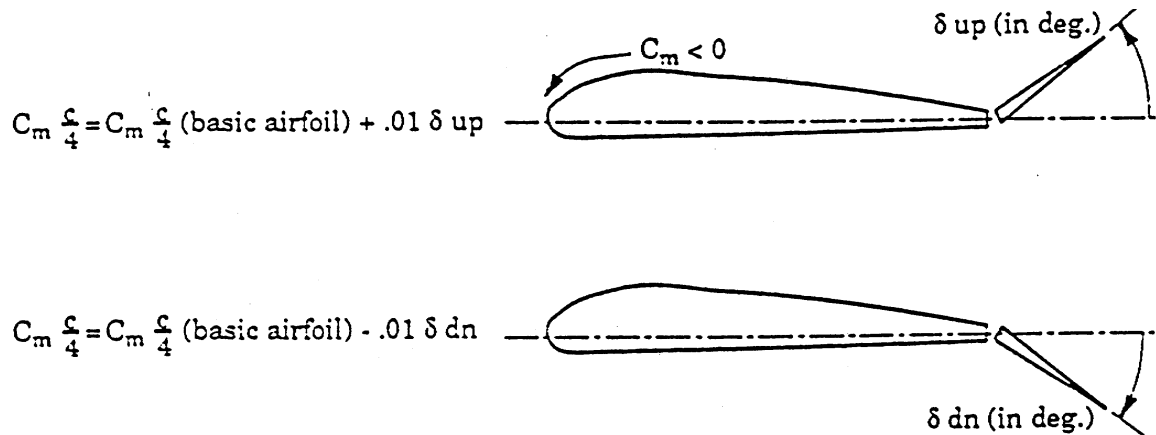

Figure 5

- Note: (1) Some wing structures may need checking for torsion at  $V_D$ . In this case, 1/3 of the aileron deflection shall be used.
- (2) If the landing gear is attached to the wing, the wing structure shall be justified for the ground loads as well.

### 33. Rear Fuselage Loads

The rear fuselage shall be substantiated for:

- (a) The symmetrical horizontal tail load of Appendix A, paragraph A.1;
- (b) The unsymmetrical horizontal tail loads of Appendix, A paragraph A.2;
- (c) The vertical tail loads of Appendix A, paragraph A.3; and
- (d) The tailwheel loads of Appendix B and sections 39. through 42.

### 34. Forward Fuselage Loads

The forward fuselage shall be substantiated for each of the following conditions:

- (a) Inertia forces of  $n = 4$  and  $n = -2$   
(see also "Ground Loads" if  $n_j$  of section 38 is larger than 3.33) and:
- (b) Engine torque in  $N \times m$  (1bs x inches) equal to :

$$K \times 19070 \times \frac{kW_{take-off}}{tr / \min_{take-off}} \left( K \times 125850 \times \frac{BHP_{take-off}}{tr / \min_{take-off}} \right)$$

Where:

- (1) For 4-stroke engines:  $K = 8, 4, 3, 2$ , with 1, 2, 3 and 4 cylinder engines respectively; or
- (2) For 2-stroke engines:
- (i)  $K = 2$  for engines with three or more cylinders; or
- (ii)  $K = 3$  or  $6$ , for engines with two or one cylinder respectively.
- (c) An independent side load on the engine  
( $n$  lateral = + or - 1.5); and
- (d) Nose wheel loads, if applicable.

### 35. Control Surface Loads

- (a) Control surface load conventions shall be:
- (1) + = up
- (2) - = down
- (b) The control surface loads specified in Appendix A shall be used.

### 36. Ground Gust Conditions

- (a) All control surfaces and the wing shall be designed for a reverse airflow,  $V_R$ , as follows:

$$V_R = 0.645 \times \sqrt{\frac{Mg}{S}} + 4.47 \text{ m/s} \left( = 10 \times \left( 1 + \sqrt{\frac{W}{S}} \right) \text{ mph} \right)$$

- (b)  $C_L$  (surface) = -0.8 and a triangular chordwise pressure distribution with the peak at the trailing edge shall be used.

### 37. Control System and Supporting Structure

- (a) When rudder control surfaces are installed, the control system and supporting structures shall be designed for at least 125% hinge moments resulting from the surface load from section 35. but need not exceed the loads from the following pilot forces:
- (1) at the grip of the stick:
    - (i) 445 N (100 lbs) in pitch
    - (ii) 178 N (40 lbs) in roll limit loads: and
  - (2) at the rudder pedals:
    - 578 N (130 lbs) in yaw.
- (b) When dual controls are installed, the relevant system shall be designed for the pilots operating in opposition.
- (c) Control surface mass balance weights shall be designed for:
- (1) 24 'g' ultimate normal to the surface; and
  - (2) 12 'g' ultimate fore and aft and parallel to the hinge line.
- (d) Right and left flaps shall be synchronized for symmetrical operation.
- (e) All primary controls shall have stops within the system to withstand the greater of pilot force, 125% surface loads, or ground gust loads.
- (f) The secondary controls shall be designed for the maximum forces a pilot is likely to apply in normal operation.

### 38. Ground Load Conditions

- (a) The basic landing conditions of Appendix C of Chapter 523 of the Airworthiness Manual are reproduced in Appendix B of this publication.
- (b) For advanced ultra-light aeroplanes the basic landing conditions of Appendix B of this publication are simplified as follows:
- L = ratio of the assumed wing lift to the aeroplane weight = 2/3;  
 K = 0.25;  
 n =  $n_j + .67$ , load factor; and,  
 $n_j$  = load factor on wheels, as defined in para (c) of this section.

- (c) The load factor on the wheels,  $n_j$ , may be computed as follows:

$$n_j = \frac{h + d / 3}{ef x d}$$

where:

h = drop height cm (in) =

$$1.32 x \sqrt{\frac{Mg}{s}} \text{ (cm)} \left( = 3.6 x \sqrt{\frac{P}{S}} \text{ (inches)} \right)$$

d = total shock absorber travel cm (inches) =

$= d(\text{tire}) + d(\text{shock});$

$e_f$  = shock efficiency;

$e_f \times d = .5 \times d$  for tire and rubber or spring shocks; or  
 $= .5 \times d (\text{tire}) + .65 \times d (\text{shock})$  for hydraulic shock absorbers.

If  $n_j$  is larger than 3.33, all concentrated masses (engine, fuel tanks, occupant seats, ballast, etc...) must be substantiated for a limit landing load factor of  $n_j + .67 = n$  which is greater than 4.

Note: The ultimate landing loads are the limit loads specified in this publication multiplied by the usual safety factor of 1.5.

### 39. Side Load Conditions

Side load conditions on main wheels (level attitude) are given by the following:

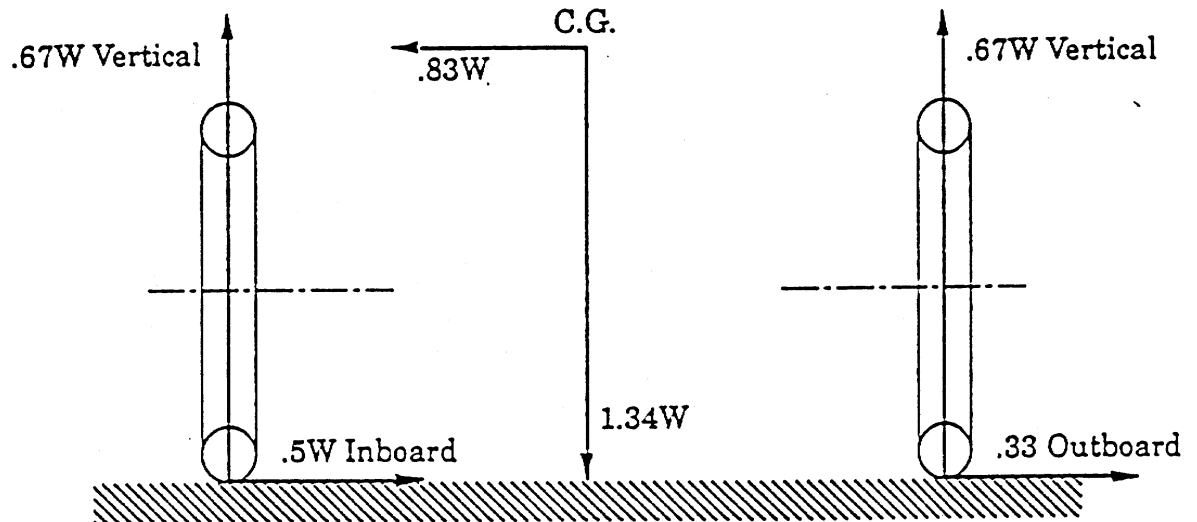

Figure 6

### 40. Braked Roll Conditions

Braked roll conditions on main wheels (level attitude) are given by the following:

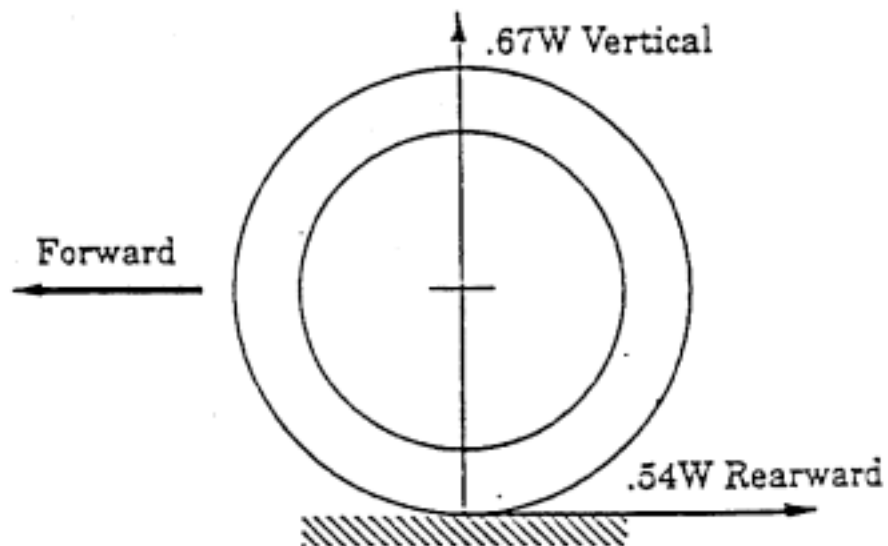

Figure 7

## 41. Supplementary Conditions for Tail Wheel

Tail wheel conditions (tail down attitude) are given by the following:

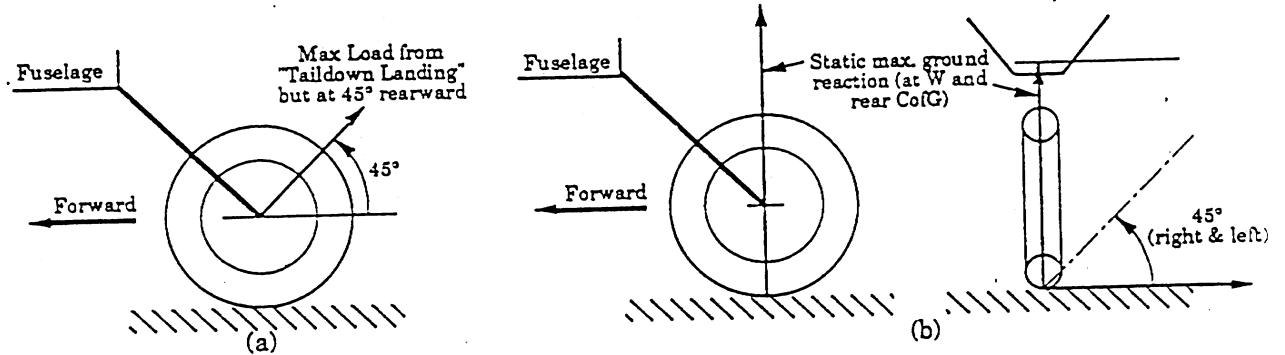

Figure 8

## 42. Supplementary Conditions for Nose Wheel

Supplementary conditions for nose wheel (static attitude) are given by the following (static load is maximum for weight and CG combination):

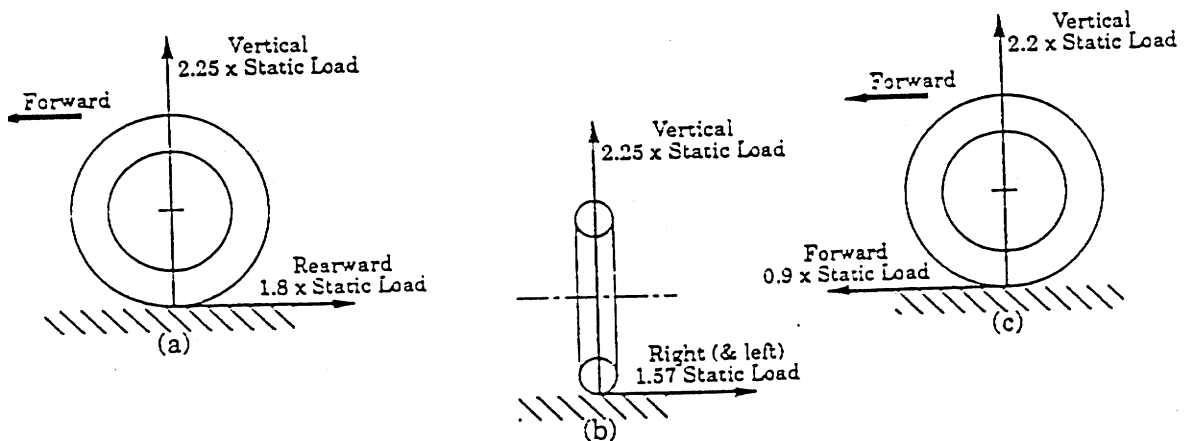

Figure 9

Note: Shock absorbers and tires in static position.

**43. Water Load Conditions**

- (a) The structure of seaplanes and amphibians must be designed for water loads developed during take-off and landing with the aeroplane in any attitude likely to occur in normal operations at appropriate forward and sinking velocities under the most severe sea conditions likely to be encountered.
- (b) Unless the applicant makes a rational analysis of the water loads, or uses the standards in ANC-3, or sufficient service experience is available, sections 525.523 through 525.537 of Chapter 525 of the Airworthiness Manual apply.

**44. Emergency Landing Conditions**

The structure must be designed to protect each occupant during emergency landing conditions when occupants (through seat belts and/or harnesses) as well as any concentrated weight (such as engine, baggage, fuel, ballast etc.) at the rear of the occupants, experience the static inertia loads corresponding to the following ultimate load factors (these are three independent conditions):

- (1) 3 'g' up;
- (2) 9 'g' forward; and
- (3) 1.5 'g' sideways.

**45. Tie-down Points**

Tie-down points shall be designed for the maximum wind at which the aeroplane may be tied down in the open. If reasonable, VR as defined in section 36. may be used.

## Chapter D - Design and Construction

### 46. General

The integrity of any novel or unusual design feature having an important bearing on safety, shall be established by test.

### 47. Materials and Workmanship

Materials shall be suitable and durable for the intended use and design values (strength) must be chosen so that the probability of any structure being understrength because of material variations is extremely remote.

### 48. Fabrication Methods

- (a) Workmanship of manufactured parts, assemblies, and aircraft shall be of high standards.
- (b) Methods of fabrication shall produce consistently sound structures.
- (c) Process specification shall be followed where required.

### 49. Self-Locking Nuts

No self-locking nut shall be used on any bolt subject to rotation in operation unless a non-friction locking device is used in addition to the self-locking device.

### 50. Protection of Structure

Protection of the structure against weathering, corrosion, and abrasion, as well as suitable ventilation and drainage shall be provided.

### 51. Accessibility

Accessibility for principal structural and control system inspection, adjustment, maintenance, and repair shall be provided.

### 52. Flutter

No part of the aeroplane shall show heavy buffeting, excessive vibration, flutter (with proper attempts to induce it), nor control reversal nor divergence, in the complete speed range up to  $1.1 V_{NE}$ . (*Note: refer to FAA Advisory Circular 23.629-1A - Means of Compliance with section 23.629, Flutter*).

### 53. Proof of Strength - Wings

The strength of wings shall be investigated by conservative analysis, or tests, or a combination of both. Structural analysis alone may be used only if the structure conforms to those for which experience has shown this method to be reliable.

**54. Control System - Operation Test**

It must be shown by functional test that the control system is free from jamming, excessive friction, and excessive deflection when the pilot forces specified in section 37 are applied from the cockpit.

**55. Pilot Compartment**

Pilot comfort, good visibility (instruments, placards and outside), accessibility, exit (fire), and ability to reach all controls for smooth and positive operation as well as pilot protection as far as practical in emergency landing shall be provided.

## Chapter E - Powerplant

### 56. Installation

The powerplant installation shall be easily accessible for inspection and maintenance. The powerplant attachment to the airframe is part of the structure and shall withstand the applicable load factors.

### 57. Engines

Unless reliable and extensive operational experience is available, the powerplant (engine, reduction drive, propeller, exhaust, and other accessories) shall comply with the requirements of Chapter 522 of the Airworthiness Manual, NASAD engine standard, or equivalent specifications.

### 58. Fuel Tank Tests

The fuel tank shall be pressure tested to 24.13 kPa (3.5 PSI, 8 ft. water column) and installed to withstand prescribed load factors.

### 59. Fuel Tank Vents

A fuel tank vent which does not \_iphon in flight shall be provided.

### 60. Fuel Strainer or Filter

A fuel filter accessible for drainage and/or cleaning and replacement shall be included in the system.

### 61. Induction System Icing Protection

Preheated air shall be available, if required by the engine, to prevent carburetor icing.

INTENTIONALLY LEFT BLANK

## Chapter F - Equipment

### 62. Flight and Navigation Instruments

(a) The following instruments are required:

- (1) Airspeed indicator (*Note: see paragraph 73.(a)*);
- (2) Reserved

(b) The following flight and navigation instruments are recommended:

- (1) Altimeter; and
- (2) Magnetic compass.

### 63. Powerplant Instruments

(a) The following powerplant instruments are required:

- (1) Fuel quantity indicator;
- (2) Tachometer (RPM);
- (3) Engine 'kill' switch; and
- (4) Engine instruments as required by engine manufacturer.

### 64. Miscellaneous Equipment

Master switch and electrical protective devices shall be provided when an electrical system is installed. The battery shall be installed to withstand the load factors and to prevent corrosion.

### 65. Safety Belts and Harnesses

Occupant seat belts, harnesses and their attachments, baggage compartment and restraints shall be designed for the appropriate load factors.

INTENTIONALLY LEFT BLANK

## Chapter G - Operating Limitations and Information

### 66. General

The operating limitations and other information necessary for safe operation shall be established and made available to the pilot, as prescribed in sections 67. through 74

### 67. Weight and Centre of Gravity

Weight and Centre of Gravity limitations shall be provided, including reference and levelling data.

### 68. Powerplant Limitations

Powerplant limitations shall be provided.

### 69. Instructions for Continued Airworthiness

Maintenance information for inspections shall be provided.

### 70. Control Markings

Each control (except primary controls) shall be suitably placarded.

### 71. Miscellaneous Markings and Placards

Baggage, ballast location, etc., shall be suitably indicated.

### 72. Aeroplane Manual

Each aeroplane or kit shall be accompanied by an owners manual and/or information to be placarded on the aeroplane giving the data specified in this publication.

### 73. Operating Limitations

(a) The following IAS information shall be provided:

- (1) Stall speed at gross weight ( $V_{S1}$ );
- (2) Flap extended speed range ( $V_{SO}$  to  $V_F$ );
- (3) Manoeuvring speed ( $V_A$ ); and
- (4) Never exceed speed ( $V_{NE}$ ).

(b) Load factors, prohibited manoeuvres and operating limitations shall be provided.

### 74. Operating Procedures

The following operating procedures and handling information shall be provided:

- (a) Loading procedures (occupants, baggage, fuel, ballast, weight, and CG as required) and their limitations;
- (b) Preflight check;

- (c) Engine starting
- (d) Taxiing
- (e) Take-off
- (f) Climb at  $V_x$  and  $V_y$
- (g) Cruise
- (h) Approach
- (i) Landing
- (j) Cross-wind and wind limitations
- (k) Balked landing procedures
- (l) Information on stalls, spins and any other useful pilot information
- (m) Performances at various weights, CGs, altitudes, air temperatures
- (n) Take-off and landing distances, rate of climb, cruise speeds, RPMs and fuel consumption;
- (o) Tie-down instructions.

INTENTIONALLY LEFT BLANK

## APPENDIX A

### 75. CONTROL SURFACE LOADINGS (Refer to sections 33 and 35)

The following applies to aircraft equipped with conventional horizontal and vertical tail surfaces.

- A.1 Symmetrical horizontal and vertical tail air loads: ( $C_n = .7$  at  $V_A$ )

$$+_{-} \bar{w} = 4.8 + 2.1 \frac{W}{S} \text{ 8 but larger than 12 PSF}$$

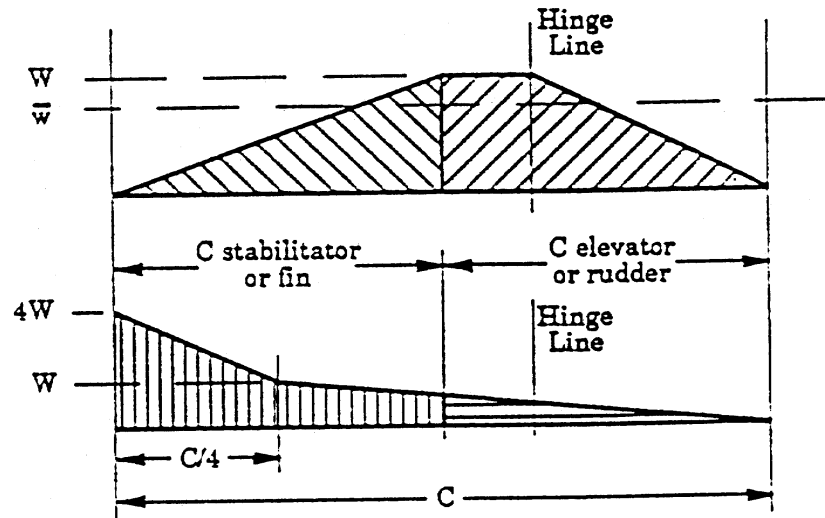

- A.2 Unsymmetric horizontal tail air loads: 100%  $w$  on one side, 65%  $w$  on the other side.

- A.3 Aileron air loads: ( $C_n = .6$  at  $V_A$ )

$$+_{-} \bar{w} = 1.8 \frac{W}{S} \text{ 9 but larger than 12 PSF}$$

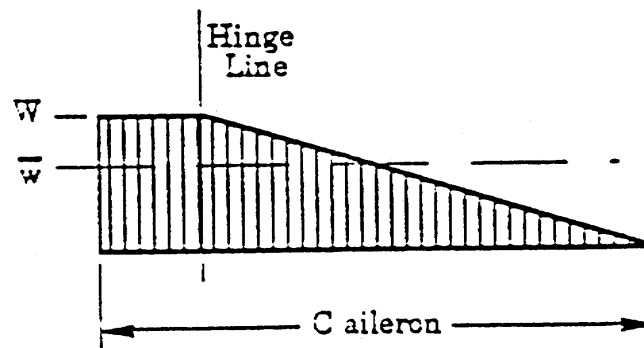

## A.4 Flap air loads:

$$(a) \quad \bar{w}_{up} = 2.5 \frac{W}{S} \frac{Cn_{flaps}}{1.6} \text{ 10 but larger than 12 PSF}$$

(For conventional flaps  $Cn_{flaps} = 1.6$  may be used)

$$(b) \quad \bar{w}_{down} = \frac{\bar{w}_{up}}{4} \text{ 11}$$

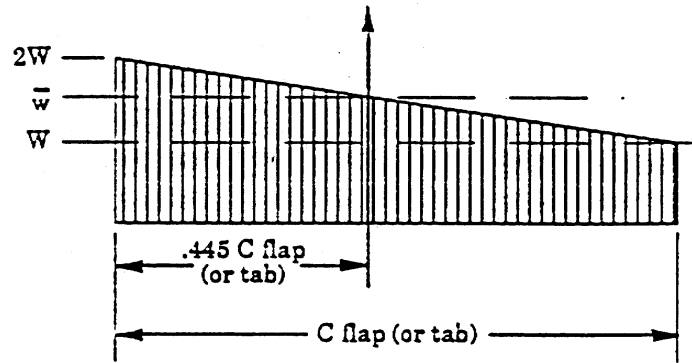
A.5 Trim tab air loads: ( $Cn_t = .6$  at  $V_D$ , or  $1.35$  at  $V_A$ )

$$+_{-} \bar{w} = 4 \frac{W}{S} \text{ 12, but larger than 12PSF}$$

Same distribution as in the flap case.

*Note: See Chapter 523, Appendix A for design speeds greater than the speeds specified in this publication.*

A.6 Speed brake and spoiler air loads: ( $Cn_s = 1.35$  at  $V_A$ )  
(to be used and placarded up to  $V_{SP}$ )

$$\bar{w} = 4 \frac{W}{S} \left( \frac{V_{SP}}{V_A} \right)^2 \text{ 13, but larger than 12 PSF}$$

Rectangular distribution.

## APPENDIX B

### 76. BASIC LANDING CONDITIONS

(Refer to section 38)

Condition	Tail wheel Type		Nose wheel type		
	Level Landing	Tail-down Landing	Level Landing with inclined reactions	Level Landing with nose wheel just clear of ground	Tail-down Landing
Reference Section	523.479 (a) (1)	523.481 (a) (1)	523.479 (a) (2) (ii)	523.479 (a) (2) (ii)	523.481 (a) (2) & (b)
Vertical component at c.g.	nW	nW	nW	nW	nW
Fore and aft component at c.g.	KnW	0	0	KnW	0
Lateral component in either direction at c.g.	0	0	0	0	0
Shock absorber extension (hydraulic shock absorber)	Note 2	Note 2	Note 2	Note 2	Note 2
Shock absorber deflection (rubber or spring shock absorber) percent	100%	100%	100%	100%	100%
Tire deflection	Static	Static	Static	Static	Static
Main wheel loads	$V_r$	$(n-L)W$	$(n-L)Wa'/d'$	$(n-L)W$	$(n-L)W$
(both wheels)	$D_r$	KnW	KnWa'/d'	KnW	0
Tail (nose) wheels	$V_t$	0	$(n-L)Wa'/d'$	0	0
loads	$D_t$	0	KnWa'/d'	0	0
Notes	1, 3, & 4	4	1	1, 3, & 4	3 & 4

(reproduced from Chapter 523 of the Airworthiness Manual for user convenience)

- Note 1. K may be determined as follows:  $K=0.25$  for  $W=3,000$  pounds or less;  $K=0.33$  for  $W=6,000$  pounds or greater, with linear variation of K between these weights.
- Note 2. For the purpose of design, the maximum load factor is assumed to occur throughout the shock absorber stroke from 25 percent deflection to 100 percent deflection unless otherwise shown and the load factor must be used with whatever shock absorber extension is most critical for each element of the landing gear.
- Note 3. Unbalanced moments must be balanced by a rational conservative method.
- Note 4. L is defined in 523.725(b).
- Note 5. n is the limit inertia load factor, at the c.g. of the aeroplane, selected under 523.473(d), (f), and (g).

# APPENDIX B

## BASIC LANDING CONDITIONS

### BASIC LANDING CONDITIONS

TAIL WHEEL TYPE

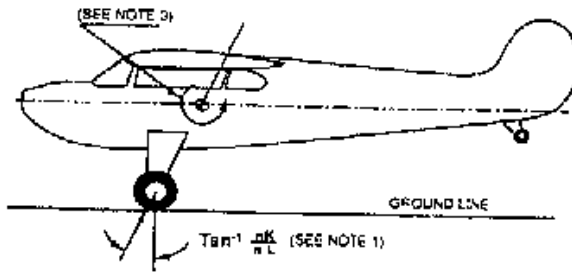

LEVEL LANDING

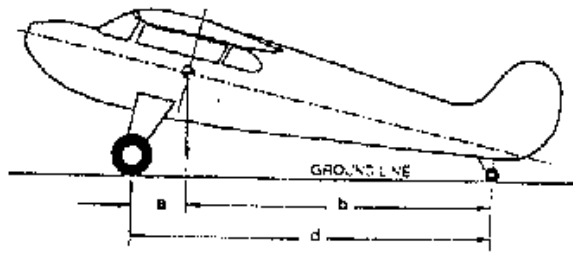

TAIL DOWN LANDING

NOSE WHEEL TYPE

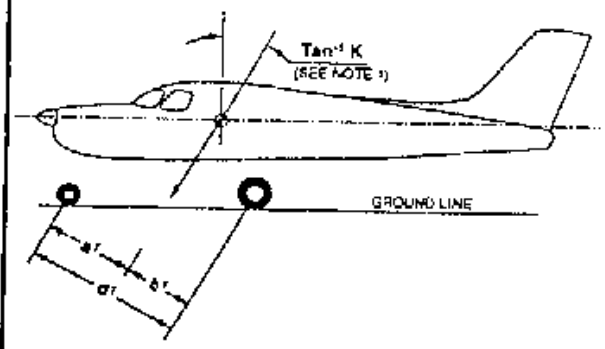

LEVEL LANDING WITH INCLINED REACTIONS

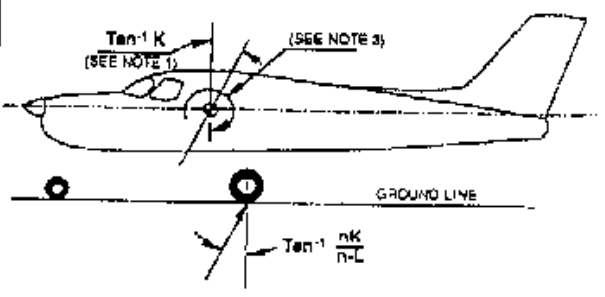

LEVEL LANDING WITH NOSE WHEEL JUST CLEAR OF GROUND

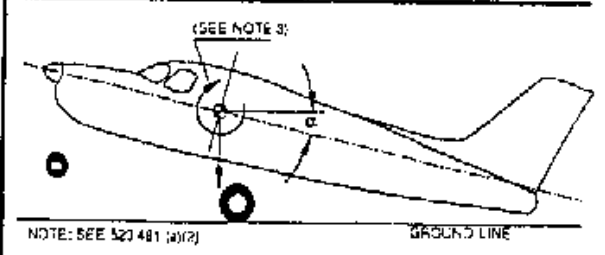

TAIL DOWN LANDING

NOTE: SEE 520 481 (a)(2)