

# BALANCING DAMPER

*Halton UTK for balancing*

Halton UTK dampers are used to balance airflow rates in ductwork. Dampers meet international standards for rectangular and round ducts. In the open position, the blades face the direction of airflow and do not cause a significant pressure loss. The maximum operation temperature of a standard damper is +100 °C (with special models +200 °C).

The UTK is used for the adjustment and balancing of airflow rates in applications where damper leakage does not have significant importance. The damper includes silicon seals in the blades. In the closed position, UTK damper leakage class is 1 according the prEN1751 standard.



## Features

- Outer frame and blades of galvanized or stainless steel. Blades of double sheet construction, silicon sealings. The slide bearings are self-lubricating polyamide and molybdenum sulphide alloys. Stainless steel or bronze bearings available as options. The shaft to the motor is a rectangular bar 15 mm x 15 mm.
- Leakage class of a closed damper according to prEN 1751 class 1
- For balancing of air intake and exhaust
- Automatic electrical, pneumatic or manual operation system available
- UTK dampers can be supplied with connection pieces for round ducts
- Maximum operation pressure 2000 Pa and maximum velocity 15 m/s

## General UTK drawing

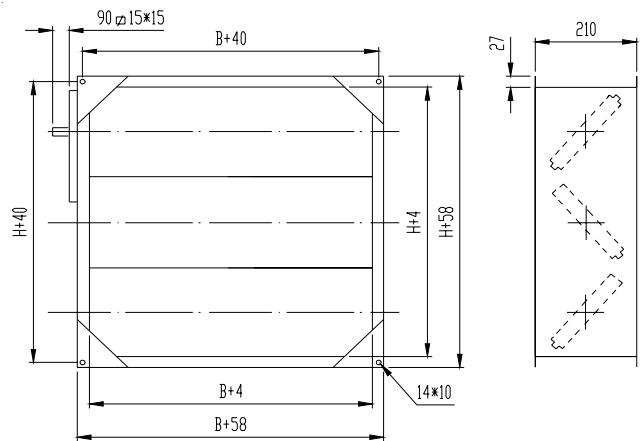

## UTK dimensions and material thickness

UTK balancing dampers meet international standards for both rectangular (width B 100-2400 mm and height H 100-2400 mm) and circular ducts (Ø100-1250 mm). Special non-standard dimensions available on request. Casing thickness 1 mm.

## General UTK drawing, circular connections

