

# Channel Assignment for Wireless Networks Modelled as $d$ -dimensional Square Grids

Aniket Dubhashi<sup>1</sup>, Shashanka MVS<sup>1</sup>, Amrita Pati<sup>1</sup>, Shashank R.<sup>1</sup>, and Anil M. Shende<sup>2</sup>

<sup>1</sup> Birla Institute of Technology & Science, Pilani 333031, India  
{f1999011,f1999154,f1999013,f1999025}@bits-pilani.ac.in

<sup>2</sup> Roanoke College, Salem, VA 24153, USA  
shende@roanoke.edu

**Abstract.** In this paper, we study the problem of channel assignment for wireless networks modelled as  $d$ -dimensional grids. In particular, for  $d$ -dimensional square grids, we present optimal assignments that achieve a channel separation of 2 for adjacent stations where the reuse distance is 3 or 4. We also introduce the notion of a colouring schema for  $d$ -dimensional square grids, and present an algorithm that assigns colours to the vertices of the grid satisfying the schema constraints.

## 1 Introduction

The enormous growth of wireless networks has made the efficient use of the scarce radio spectrum important. A “Frequency Assignment Problem” (FAP) models the task of assigning frequencies (channels) from a radio spectrum to a set of transmitters and receivers, satisfying certain constraints [8]. The main difficulty in an efficient use of the radio spectrum is the *interference* caused by unconstrained simultaneous transmissions. Interferences can be eliminated (or at least reduced) by means of suitable *channel assignment* techniques, which partition the given radio spectrum into a set of disjoint channels that can be used simultaneously by the stations while maintaining acceptable radio signals. Since radio signals get attenuated over distance, two stations in a network can use the same channel without interferences provided the stations are spaced sufficiently apart. Stations that use the same channel are called *co-channel stations*. The minimum distance at which a channel can be reused with no interferences is called the *co-channel reuse distance* (or simply *reuse distance*) and is denoted by  $\sigma$ .

In a *dense* network – a network where there are a large number of transmitters and receivers in a small area – interference is more likely. Thus, reuse distance needs to be high in such networks. Moreover, channels assigned to nearby stations must be separated in value by at least a gap which is inversely proportional to the distance between the two stations. A minimum *channel separation*  $\delta_i$  is required between channels assigned to stations at distance  $i$ , with  $i < \sigma$ , such that  $\delta_i$  decreases when  $i$  increases [7]. The purpose of channel assignment algorithms is

to assign channels to transmitters in such a way that (1) the co-channel reuse distance and the channel separation constraints are satisfied, and (2) the *span* of the assignment, defined to be the difference between the highest and the lowest channels assigned, is as small as possible [2].

In this paper, we investigate the channel assignment problem, described informally above, for networks that can be modelled as grids in  $d$  dimensions,  $d \geq 3$ . In Section 3 we define the infinite  $d$ -dimensional square and cellular grids, and show that a solution for the channel assignment problem for the  $d$ -dimensional square (cellular) grid places an upper bound on solutions for the problem for a suitable  $d'$ -dimensional cellular (square) grid. These results partly motivate our study of the channel assignment problem in higher dimensional grids. Another motivation is that when the networks of several service providers overlap geographically, they must use different channels for their clients. The overall network can then be modelled in a suitably higher dimension.

The main focus of the paper is a study of the problem for networks arranged as  $d$ -dimensional square grids. We consider the restricted problem requiring a channel separation of 1 for all but adjacent stations, and a larger (than 1) separation for adjacent stations. In Section 4, we present optimal assignments for  $d$ -dimensional square grids for  $\sigma = 3, 4$  with a channel separation constraint of 2 for adjacent stations. Finally, in Section 4.5, we introduce the notion of a colouring schema for  $d$ -dimensional square grids and present an algorithm that assigns colours to the vertices of the grid satisfying the schema constraints.

## 2 Preliminaries

Formally, the *channel assignment problem with separation* (CAPS) can be modelled as an appropriate colouring problem on an undirected graph  $G = (V, E)$  representing the network topology, whose vertices in  $V$  correspond to stations, and edges in  $E$  correspond to pairs of stations that can hear each other's transmission [2]. For a graph  $G$ , we will denote the distance between any two vertices in the graph, i.e., the number of edges in a shortest path between the two vertices, by  $d_G(\cdot, \cdot)$ . (When the context is clear, we will denote the distance as simply  $d(\cdot, \cdot)$ .) CAPS is then defined as:

### **CAPS** ( $G, \sigma, \delta$ )

Given an undirected graph  $G$ , an integer  $\sigma > 1$ , and a vector of positive integers  $\delta = (\delta_1, \delta_2, \dots, \delta_{\sigma-1})$ , find an integer  $g > 0$  so that there is a function  $f : V \rightarrow \{0, \dots, g\}$ , such that for all  $u, v \in G$ , for each  $i$ ,  $1 \leq i \leq \sigma - 1$ , if  $d(u, v) = i$ , then  $|f(u) - f(v)| \geq \delta_i$ .

This assignment is referred to as a  $g$ - $L(\delta_1, \delta_2, \dots, \delta_{\sigma-1})$  colouring of the graph  $G$  [6], and **CAPS** ( $G, \sigma, \delta$ ) is sometimes referred to as the  $L(\delta)$  colouring problem for  $G$ . Note that a  $g$ - $L(\delta_1, \delta_2, \dots, \delta_{\sigma-1})$  uses only the  $(g + 1)$  colours in the set  $\{0, \dots, g\}$ , but does *not* necessarily use all the  $(g + 1)$  colours. A  $g$ - $L(\delta_1, \delta_2, \dots, \delta_{\sigma-1})$  colouring of  $G$  is *optimal* iff  $g$  is the smallest number witnessing a solution for **CAPS** ( $G, \sigma, \delta$ ).

Finding the optimal colouring for general graphs has been shown to be *NP*-complete. The problem remains *NP*-complete even if the input graphs are restricted to planar graphs, bipartite graphs, chordal graphs, and split graphs [4]. Most of the work on this problem has dealt with specific graphs such as grids and rings, for small reuse distance ( $\sigma$ ) values, and for small channel separation ( $\delta_i$ ) values, e.g., optimal  $L(1, 1)$  colourings for rings and bidimensional grids [1], optimal  $L(2, 1)$  and  $L(2, 1, 1)$  colourings for hexagonal, bidimensional, and cellular grids [2], etc. Recently, Bertossi et al [3] exhibited optimal  $L(\delta_1, 1, \dots, 1)$  colourings, for  $\delta_1 \leq \lfloor \sigma/2 \rfloor$ , for bidimensional grids and rings. (See [3] for a succinct literature survey of this problem.) Below, we refer to  $L(\cdot, 1, \dots, 1)$  colourings by  $L(\cdot, \mathbf{1}_k)$  colourings.

As pointed out in [2], a lower bound for the  $L(1, \mathbf{1}_k)$  colouring problem is also a lower bound for the  $L(\delta, \mathbf{1}_k)$ ,  $\delta > 1$ . Given an instance of **CAPS**, consider the augmented graph obtained from  $G$  by adding edges between all those pairs of vertices that are at a distance of at most  $\sigma - 1$ . Clearly, then, the size (number of vertices) of any clique in this augmented graph places a lower bound on an  $L(1, \mathbf{1}_{\sigma-1})$  colouring for  $G$ ; the best such lower bound is given by the size of a maximum clique in the augmented graph.

In each graph,  $G$ , for each  $\sigma$ , we identify a canonical sub-graph,  $T(G, \sigma)$ , of the graph so that the vertices of  $T(G, \sigma)$  induce a clique in the augmented graph of the graph. We will refer to  $T(G, \sigma)$  as a *tile*. When the context is clear, we will refer to the size of  $T(G, \sigma)$  simply as  $c(\sigma)$ .

Most (but not all) of the assignment schemes described in this paper follow the pattern: for a given graph  $G$ , and for a given  $\sigma$ , (1) identify  $T(G, \sigma)$ , (2) find the number of vertices in  $T(G, \sigma)$ , and hence a lower bound for the given assignment problem, (3) describe a colouring scheme to colour all the vertices of  $T(G, \sigma)$ , (4) demonstrate a tiling of the entire graph made up of  $T(G, \sigma)$  to show that the colouring scheme described colours the entire graph, and (5) show that the colouring scheme satisfies the given reuse distance and channel separation constraints.

### 3 Channel Assignments in Higher Dimensional Grids

In this section we relate  $L(\delta_1, \delta_2, \dots, \delta_{\sigma-1})$  colourings for  $d$ -dimensional cellular and square grids.

For any  $d$ -dimensional lattice,  $\mathcal{L}$ , the minimal distance in the lattice is denoted by  $\mu(\mathcal{L})$ . The infinite graph, denoted  $\mathcal{G}(\mathcal{L})$ , corresponding to the lattice  $\mathcal{L}$  consists of the set of lattice points as vertices; each pair of lattice points that are at a distance  $\mu(\mathcal{L})$  constitute the edges of  $\mathcal{G}(\mathcal{L})$ . Henceforth, we will not make a distinction between the lattice points in  $\mathcal{L}$  and the corresponding vertices in  $\mathcal{G}(\mathcal{L})$ . For any lattice  $\mathcal{L}$ , for any two points  $u$  and  $v$  in  $\mathcal{L}$ ,  $d_{\mathcal{G}(\mathcal{L})}(\cdot, \cdot)$  will denote the distance between vertices  $u$  and  $v$  in  $\mathcal{G}(\mathcal{L})$ .

The lattice  $\mathbf{Z}^d$  is the set of ordered  $d$ -tuples of integers, and  $\mathbf{A}_d$  is the hyperplane that is a subset of  $\mathbf{Z}^{d+1}$ , and is characterised as the set of points in  $\mathbf{Z}^{d+1}$  such that the coordinates of each point add up to zero.  $\mu(\mathbf{Z}^d) = 1$ , and the minimal length vectors in  $\mathbf{Z}^d$  are the unit vectors in each dimension. For each

$d > 0$ , for each  $i, j, 0 \leq i, j \leq d, i \neq j$ , define  $\lambda_{ij}^d = (x_0, \dots, x_d)$  where  $x_i = 1$ ,  $x_j = -1$ , and for each  $k, 0 \leq k \leq d, k \neq i, j, x_k = 0$ . Then,  $\mu(\mathbf{A}_d) = \sqrt{2}$ , and the set of minimal length vectors in  $\mathbf{A}_d$  is  $\{\lambda_{ij}^d \mid i, j, 0 \leq i, j \leq d, i \neq j\}$ . (See [5, 9] for more on these lattices.)

The infinite  $d$ -dimensional square grid is, then,  $\mathcal{G}(\mathbf{Z}^d)$ , and the infinite  $d$ -dimensional cellular grid is  $\mathcal{G}(\mathbf{A}_d)$ .

**Theorem 1** *For all  $d \geq 2$ , if there is a  $g$ - $L(\delta_1, \delta_2, \dots, \delta_{\sigma-1})$  colouring for  $\mathbf{Z}^d$ , then there is a  $g$ - $L(\gamma_1, \gamma_2, \dots, \gamma_{\lceil \frac{\sigma}{2} \rceil - 1})$  colouring for  $\mathbf{A}_{d-1}$  where, for each  $i, 1 \leq i \leq \lceil \frac{\sigma}{2} \rceil - 1$ ,  $\gamma_i = \delta_{2i}$ .*

*Proof.* Consider a point  $x = (x_0, \dots, x_{d-1})$  that is in the intersection of  $\mathbf{Z}^d$  and  $\mathbf{A}_{d-1}$ . Then,  $d_{\mathbf{Z}^d}(x, 0) = 2 \cdot d_{\mathbf{A}_{d-1}}(x, 0)$ , thus giving us the theorem.  $\square$

**Theorem 2** *For all  $n \geq 2$ , if there is a  $g$ - $L(\delta_1, \delta_2, \dots, \delta_{\sigma-1})$  colouring for  $\mathbf{A}_d$ , then there is a  $g$ - $L(\delta_1, \delta_2, \dots, \delta_{\sigma-1})$  colouring for  $\mathbf{Z}^{\lfloor \frac{d+1}{2} \rfloor}$ .*

*Proof.* Consider the subset of minimal length vectors in  $\mathbf{A}_d$  given by  $\{\lambda_{i(d-i)}^d \mid 0 \leq i < \lfloor \frac{d+1}{2} \rfloor\}$ . Clearly, this subset consists of  $\lfloor \frac{d+1}{2} \rfloor$  mutually orthogonal vectors, and hence is a basis for  $\mathbf{Z}^{\lfloor \frac{d+1}{2} \rfloor}$ . Thus, the infinite graph for  $\mathcal{G}(\mathbf{Z}^{\lfloor \frac{d+1}{2} \rfloor})$  is a subgraph of  $\mathcal{G}(\mathbf{A}_d)$ , and hence the result.  $\square$

## 4 Colourings for $\mathcal{G}(\mathbf{Z}^d)$

As mentioned in Section (1), we first identify the canonical sub-graph  $T(\mathcal{G}(\mathbf{Z}^d), \sigma)$ , and then find lower bounds on the colourings of  $\mathcal{G}(\mathbf{Z}^d)$ . We then present optimal colouring schemes for  $\mathcal{G}(\mathbf{Z}^d)$ , for  $\sigma = 3, 4$ , with a separation constraint of 2 for adjacent vertices. We introduce the notion of a colouring schema for  $\mathcal{G}(\mathbf{Z}^d)$ , and also prove that the colouring schemes presented have running times of  $O(d)$ .

### 4.1 Lower bound

The lower bound on the colouring of  $\mathcal{G}(\mathbf{Z}^d)$  is the number of vertices in  $T(\mathcal{G}(\mathbf{Z}^d), \sigma)$ , denoted by  $c(\sigma)$ . Henceforth, we will refer to this number by  $n(\sigma, d)$ . Note that  $n(\sigma, 1) = \sigma$ . It can be proved that

$$n(\sigma, d) = n(\sigma, d-1) + 2 \sum_{i=1}^{\lfloor \frac{\sigma}{2} \rfloor} n(\sigma - 2i, d-1).$$

### 4.2 Colouring Strategy

Before we present the actual colouring schemes, we present an intuitive discussion of the strategy that we will use to colour  $\mathcal{G}(\mathbf{Z}^d)$ .

We will use the notation  $(x_0, \dots, x_i, \dots, x_{d-1})$  to denote the vertex in  $\mathcal{G}(\mathbf{Z}^d)$ . The strategy used to colour  $\mathcal{G}(\mathbf{Z}^d)$  is to identify a *base-segment* on a *baseline*. The

baseline is the set of vertices  $(x_0, 0, \dots, 0)$ . The base-segment is the set of vertices  $(x_0, 0, \dots, 0)$  with  $0 \leq x_0 \leq B(\sigma, d)$ , where  $B(\sigma, d)$  is the number of colours used to colour  $\mathcal{G}(\mathbf{Z}^d)$ , with a reuse distance of  $\sigma$ . Note that  $B(\sigma, d) \geq n(\sigma, d)$ , as  $n(\sigma, d)$  is the lower bound on the colouring. This base-segment is *translated* to fill up  $\mathcal{G}(\mathbf{Z}^d)$ . A translation of the base-segment into the  $i^{\text{th}}$  dimension is an increase in  $x_0$ , and an increment of 1 in the  $i^{\text{th}}$  dimension. A translation, in other words is to repeat the colouring at some distance. The increase in  $x_0$  is given by the translation function  $t_i$ , where  $1 \leq i \leq d-1$ .

We thus have a function  $f$  that colours vertices on the baseline, and a function  $C$  that colours vertices of  $\mathcal{G}(\mathbf{Z}^d)$ . To prove that our colouring schema work, we will make use of a process called *dimensional collapse*, which is the inverse of the translation process described above. It is the strategy of reducing the colours assigned to arbitrary vertices in  $\mathcal{G}(\mathbf{Z}^d)$  to colours assigned to vertices on the baseline. We describe the process here.

Consider two vertices  $P = (x_0, x_1, \dots, x_{d-1})$  and  $Q = (x'_0, x'_1, \dots, x'_{d-1})$  in  $\mathcal{G}(\mathbf{Z}^d)$ , where  $x'_i - x_i = k_i$ ,  $0 \leq i \leq d-1$ . Let  $t_i$  be the translation function employed by a colouring scheme  $C$  for  $\mathcal{G}(\mathbf{Z}^d)$ . The colours assigned to  $P$  and  $Q$  will be:

$$C(P) = C(x_0, x_1, \dots, x_{d-1}) = C(x_0 - \sum_{i=1}^{d-1} x_i \cdot t_i, 0, \dots, 0), \text{ and}$$

$$C(Q) = C(x'_0 - \sum_{i=1}^{d-1} x'_i \cdot t_i, 0, \dots, 0).$$

This means the colours assigned to  $P$  and  $Q$  are the same as the colours assigned to vertices  $u = (x_0 - \sum_{i=1}^{d-1} x_i \cdot t_i, 0, \dots, 0)$  and  $v = (x'_0 - \sum_{i=1}^{d-1} x'_i \cdot t_i, 0, \dots, 0)$  on the baseline. We call  $u$  and  $v$  the *collapse points* corresponding to  $P$  and  $Q$ . Their *collapse positions* are  $CP(P)$  and  $CP(Q)$  respectively. We define the *collapse distance* as the distance between  $u$  and  $v$ . We denote it by  $CD(P, Q)$ .

$$CD(P, Q) = d(u, v) = |k_0 - \sum_{i=1}^{d-1} k_i \cdot t_i|$$

### 4.3 Optimal colouring for $\sigma = 3$

Consider the *star graph*  $S_\Delta$  which consists of a *center* vertex  $c$  with degree  $\Delta$ , and  $\Delta$  ray vertices of degree 1. We will use the following from [2].

**Lemma 1.** [2] *Let the center  $c$  of  $S_\Delta$  be already coloured. Then, the largest colour required for a  $g$ - $L(2, 1)$ -colouring of  $S_\Delta$  by the colouring function  $f$  is at least:*

$$g = \begin{cases} \Delta + 1, & f(c) = 0 \text{ or } f(c) = \Delta + 1, \\ \Delta + 2, & 0 < f(c) < \Delta + 1. \end{cases}$$

□

Every induced subgraph in  $\mathcal{G}(\mathbf{Z}^d)$ , with the distance between the vertices  $d(u, v) \leq \sigma - 1$  is a *star* graph with a center vertex of degree  $2d$  and  $2d$  ray vertices, each of degree 1, and hence we have:

**Lemma 2.** *If there is a  $g$ - $L(2, 1)$  colouring of  $\mathcal{G}(\mathbf{Z}^d)$ , then  $g \geq 2d + 2$ .  $\square$*

Lemma (2) shows that  $n(\sigma, d) \geq 2d + 3$ . We provide a colouring scheme that uses  $B(\sigma, d) = 2d + 3$  colours. The base-segment is coloured using the function:

$$f(x_0) = \begin{cases} 2d - 2x_0 + 1, & x_0 \bmod (2d + 3) \leq d, \\ 4d - 2x_0 + 4, & d + 1 \leq x_0 \bmod (2d + 3) \leq 2d + 2. \end{cases} \quad (1)$$

We define in Equation (2) the colouring scheme  $C_3$ , and later prove that it optimally colours  $\mathcal{G}(\mathbf{Z}^d)$ :

$$\begin{aligned} C_3(x_0, x_1, \dots, x_i, 0, \dots, 0) &= C_3(x_0 - (i + 1)x_i, x_1, \dots, x_{i-1}, 0, \dots, 0), \quad 1 \leq i < d, \\ C_3(x_0, 0, \dots, 0) &= f(x_0). \end{aligned} \quad (2)$$

We make the following observations about the colours assigned to the baseline:

**Lemma 3.** *For colouring the baseline,*

1. *The set of  $2d + 3$  colours used by the function  $f$  defined in Equation (1) is  $\{0, 1, \dots, 2d + 2\}$ .*
2. *Vertices are assigned consecutive colours iff they are  $((d + 1) \bmod (2d + 3))$  or  $((d + 2) \bmod (2d + 3))$  apart.*
3. *For distinct vertices  $u$  and  $v$  on the baseline,  $d(u, v) \neq 2d + 3 \implies f(u) \neq f(v)$ .  $\square$*

**Theorem 3**  $C_3$  is an optimal  $L(2, 1)$  colouring of  $\mathcal{G}(\mathbf{Z}^d)$ .

*Proof.* From Lemma (3.1), the colouring scheme  $C_3$  uses exactly  $2d + 3$  colours, with the largest colour being  $2d + 2$ . From Lemma (2), this scheme is optimal if it *works*. To prove that  $C_3$  works, we have to prove that it satisfies the co-channel reuse and the channel separation constraints.

**Adherence to the co-channel reuse constraint:** Suppose two distinct vertices  $P = (x_0, x_1, \dots, x_{d-1})$  and  $Q = (y_0, y_1, \dots, y_{d-1})$  in  $\mathcal{G}(\mathbf{Z}^d)$  are assigned the same colour. Then, the co-channel reuse constraint is satisfied if we prove that  $d(P, Q) \geq 3$ . Let us assume the contrary, i.e.  $d(P, Q) \leq 2$ .

**Case 1:**  $P$  and  $Q$  differ in  $x_0$ .

When  $P$  and  $Q$  differ in  $x_0$ , we write  $P$  and  $Q$  as follows:

$$P = (x_0, x_1, \dots, x_a, \dots, x_{d-1}), \text{ and } Q = (x'_0, x_1, \dots, x'_a, \dots, x_{d-1}),$$

where  $1 \leq a \leq d - 1$ ,  $x'_0 - x_0 = k_0$ , and  $x'_a - x_a = k_a$ ,  $1 \leq |k_0| + |k_a| \leq 2$ ,  $|k_0| > 0$ .

Performing the *dimensional collapse* on  $P$  and  $Q$ , we get:

$$\begin{aligned} CP(P) &= (x_0 - dx_{d-1} - \dots - (a+1)x_a - \dots - 2x_1, 0, \dots, 0), \\ CP(Q) &= (x'_0 - dx_{d-1} - \dots - (a+1)x'_a - \dots - 2x_1, 0, \dots, 0) \\ CD(P, Q) &= |k_0 - (a+1)k_a| \end{aligned}$$

Since the maximum value of  $a$  is  $d-1$ , we have:  $0 < |k_0 - (a+1)k_a| \leq d+1$ . This means that there are two vertices  $u$  and  $v$  on the baseline such that  $C_3(u) = C_3(P)$  and  $C_3(v) = C_3(Q)$ , and  $0 < d(u, v) \leq d+1$ . From Lemma (3.3),  $C_3(u) \neq C_3(v)$ . Therefore,  $C_3(P) \neq C_3(Q)$ , giving us a contradiction.

**Case 2:**  $P$  and  $Q$  do not differ in  $x_0$ .

In this case, we write  $P$  and  $Q$  as follows:

$$P = (x_0, x_1, \dots, x_a, \dots, x_b, \dots, x_{d-1}), \text{ and} \quad (3)$$

$$Q = (x_0, x_1, \dots, x'_a, \dots, x'_b, \dots, x_{d-1}), \text{ where} \quad (4)$$

$$1 \leq a \leq d-1 \text{ and } 1 \leq b \leq d-1, \quad (4)$$

$$x'_a - x_a = k_a \text{ and } x'_b - x_b = k_b, 1 \leq |k_a| + |k_b| \leq 2. \quad (5)$$

Performing the dimensional collapse on  $P$  and  $Q$ , we get:

$$CD(P, Q) = |-(a+1)k_a - (b+1)k_b|. \quad (6)$$

From Equations (4) and (5), and from the fact that  $a \neq b$ , we have:  $0 < CD(P, Q) \leq 2d$ . Therefore we have  $0 < d(u, v) \leq 2d$ . From Lemma (3.3),  $C_3(u) \neq C_3(v)$ . Therefore,  $C_3(P) \neq C_3(Q)$ , giving us a contradiction.

The above two cases thus prove that  $d(P, Q) \geq 3$ , thereby satisfying the channel reuse constraint.

**Adherence to the channel separation constraint:** To prove the channel separation constraint, we use Lemma (3.2). If  $P$  and  $Q$  differ in  $x_0$ , the argument in Case 1 above applies; otherwise the argument in Case 2 above applies. In either case,  $P$  and  $Q$  cannot have consecutive colours.  $\square$

#### 4.4 Optimal colouring for $\sigma = 4$

The lower bound for  $L(2, 1, 1)$  colouring is  $n(4, d) = 4d$ . Hence,  $B(4, d) \geq 4d$ . We use the following Lemma, proved in [2], about the span of an  $L(\delta_1, 1, \dots, 1)$  colouring. For the graph  $G(V, E)$ , [2] also defines  $\lambda(G)$  as the largest colour used in an optimal colouring scheme.

**Lemma 4.** [2] Consider the  $L(\delta_1, 1, \dots, 1)$ -colouring problem, with  $\delta_1 \geq 2$ , on a graph  $G = (V, E)$  such that  $d(u, v) < \sigma$  for every pair of vertices  $u$  and  $v$  in  $V$ . Then  $\lambda(G) = |V| - 1$  if and only if  $\overline{G}$  has a Hamiltonian path.  $\square$

In [2], Lemma (4) is used to prove the existence of a hole in  $L(2, 1, 1)$  colouring of  $\mathcal{G}(\mathbf{Z}^2)$ . Lemma (5) extends the proof to  $\mathcal{G}(\mathbf{Z}^d)$ .

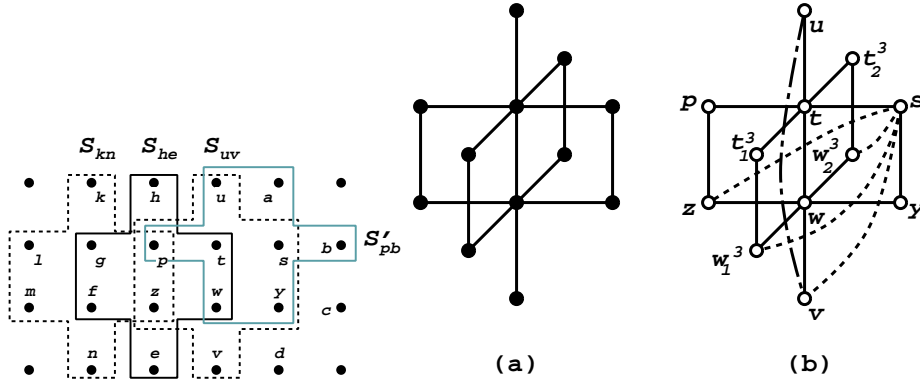

**Fig. 1.** A plane in  $\mathcal{G}(\mathbf{Z}^d)$ , (a) Induced subgraph  $M$  in  $\mathcal{G}(\mathbf{Z}^3)$ , and (b) Dummy edges in  $M$

**Lemma 5.** *If there is a  $g$ - $L(2, 1, 1)$  colouring of  $\mathcal{G}(\mathbf{Z}^d)$ , then  $g \geq 4d$ .*

*Proof.* Consider the plane  $\{(x_0, x_1, k_2, k_3, \dots, k_{d-1})\}$  in  $\mathcal{G}(\mathbf{Z}^d)$  where the first two coordinates can vary and  $k_i$ 's are fixed constants. Such a plane is shown in Figure 1. For any vertex  $x$  in this plane,  $x_1^i$  and  $x_0^i$  denote vertices above the plane of the paper and  $x_2^i$  and  $x_3^i$  denote vertices below the plane of the paper. The subscripts 1 and 0 denote distances of 1 and 2 above the plane of the paper respectively. Similarly, the subscripts 2 and 3 denote distances of 1 and 2 below the plane of the paper respectively. The superscript  $i$  denotes the dimension of the vertex, where  $(3 \leq i \leq d)$ . Consider the set of vertices which make up the induced subgraph  $T(\mathcal{G}(\mathbf{Z}^d), \sigma)$  denoted by  $M$  for notational convenience (illustrated in Figure 1a for three dimensions) in  $\mathcal{G}(\mathbf{Z}^d)$  with distance between any two vertices less than the reuse distance 4:

$$S_{uv} = \{u, t, w, v, p, z, s, y, t_1^i, t_2^i, w_1^i, w_2^i\}, \text{ and}$$

$$S'_{pb} = \{p, t, s, b, u, a, w, y, t_1^i, t_2^i, s_1^i, s_2^i\}$$

The points  $\{a, b, s_1^i, s_2^i\}$  are adjacent to  $s$ . Consider the set of vertices in  $S'_{pb}$ . Once  $S_{uv}$  has been assigned to all different colours, the vertices  $\{a, b, s_1^i, s_2^i\}$  of  $S'_{pb}$  must be assigned the colours assigned to the vertices  $\{z, v, w_1^i, w_2^i\}$  if only  $4d$  colours  $\{0, 1, \dots, 4d - 1\}$  are to be used. Due to the channel separation constraint, colours assigned to  $\{a, b, s_1^i, s_2^i\}$  must be at least two apart from the colour assigned to vertex  $s$ . This is equivalent to adding dummy edges connecting  $s$  to  $\{z, v, w_1^i, w_2^i\}$  in  $M$  induced by  $S_{uv}$ . Figure 1b shows these dummy edges in  $M$  in  $\mathcal{G}(\mathbf{Z}^3)$ . Repeating this argument for vertices  $y, z$  and  $p$  we get the dummy edges connecting  $y$  to  $\{p, u, t_1^i, t_2^i\}$ ,  $z$  to  $\{u, s, t_1^i, t_2^i\}$  and  $p$  to  $\{y, v, w_1^i, w_2^i\}$  in  $S_{uv}$ . These edges are not shown in the Figure 1b to avoid cluttering.

Four vertices,  $p, t, w$  and  $z$ , are common between the sets  $S_{uv}$  and  $S_{he}$ , and their colours are fixed. The remaining vertices  $\{h, g, f, e, p_1^i, p_2^i, z_1^i, z_2^i\}$  of  $S_{he}$

should be assigned the colours assigned to  $\{u, s, y, v, t_1^i, t_2^i, w_1^i, w_2^i\}$  in  $S_{uv}$ . We are interested in the vertices  $u$  and  $v$  in  $S_{uv}$ . We want to prove that a colouring of  $\mathcal{G}(\mathbf{Z}^d)$  satisfying all constraints implies a dummy edge  $uv$  in  $S_{uv}$ . For this, we will fix the colour of  $v$  (denoted by  $C(v)$ ) in  $S_{he}$  and consider all vertices where colour of  $u$  (denoted by  $C(u)$ ) can reoccur and prove that we can always find a set  $S_{u'v'}$  in which colours of  $u$  and  $v$  are assigned to adjacent vertices. Note that due to the co-channel reuse constraint,  $C(v)$  can reoccur at  $h, g, p_1^i$  or  $p_2^i$  in  $S_{he}$  and for each of these positions of  $v$ ,  $C(u)$  can reoccur at  $f, e, z_1^i$  or  $z_2^i$  in  $S_{he}$ . Note that for any recurrence of  $C(v)$ , if  $C(u)$  reoccurs at  $e$  then  $C(u)$  and  $C(v)$  are assigned to adjacent vertices  $e$  and  $v$  respectively. This implies a dummy edge between  $u$  and  $v$  in  $S_{uv}$ . Consider the following cases for each recurrence of  $C(v)$  when  $C(u)$  does not reoccur at  $e$ .

**Case 1:**  $C(v)$  reoccurs at  $h$  in  $S_{he}$ .

Here,  $C(u)$  and  $C(v)$  are assigned to adjacent vertices  $u$  and  $h$  respectively. This implies a dummy edge between  $u$  and  $v$  in  $S_{uv}$ .

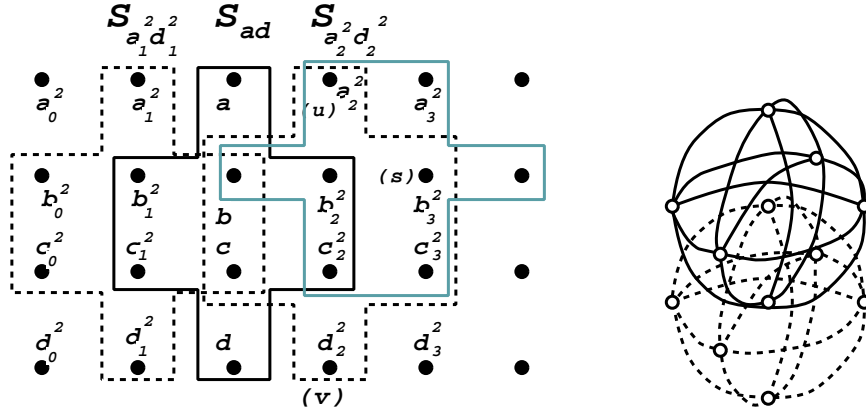

**Fig. 2.** New nomenclature for vertices in Figure 1, and  $\overline{M}$  in  $\mathcal{G}(\mathbf{Z}^3)$ .

**Case 2:**  $C(v)$  reoccurs at  $g, p_1^i$  or  $p_2^i$  in  $S_{he}$ .

To treat this case conveniently, we introduce a new nomenclature for the vertices in the plane. Figure 2 shows the new nomenclature where the vertices  $a, d, a_2^2$  and  $d_2^2$  correspond to vertices  $h, e, u$  and  $v$  respectively. As before, the superscripts denote the dimensions, with  $i = 2$  for vertices in the plane. This case can be broken down into the following two cases.

**Case 2a:**  $C(v)$  reoccurs at  $b_1^i$  and  $C(u)$  reoccurs at  $c_1^i$ .

Without loss of generality, consider the case when  $i = 2$ . Here,  $C(u)$  and  $C(v)$  are assigned to adjacent vertices  $b_1^2$  and  $c_1^2$  respectively. This implies a dummy edge between  $u$  and  $v$  in  $S_{uv}$ .

**Case 2b:**  $C(v)$  reoccurs at  $b_1^i$  and  $C(u)$  reoccurs at  $c_1^j$ , where  $i \neq j$  and  $2 \leq i, j \leq d$ .

Without loss of generality, let  $C(v)$  reoccur at  $b_1^2$ . Consider the set  $S_{a_1^2 d_1^2}$ . In this set, let  $b_1^2 = x$  for convenience. Due to co-channel reuse constraint,  $C(u)$  at  $c_1^i$  can reoccur in  $S_{a_1^2 d_1^2}$  at one of  $b_0^2, a_1^2, x_1^i$  or  $x_2^i$  all of which are adjacent to  $b_1^2$  coloured with  $C(v)$ .

The above two cases show that no matter where  $C(u)$  and  $C(v)$  reoccur in  $S_{he}$  we can always find a set  $S_{u'v'}$  in which  $C(u)$  and  $C(v)$  are assigned to adjacent vertices. Hence we have a dummy edge connecting  $u$  and  $v$  in  $S_{uv}$  as shown in Figure 1b.

Finally, let us build  $\overline{M}$ , the complement of  $M$ . Figure 2 shows  $\overline{M}$  in  $\mathcal{G}(\mathbf{Z}^3)$  and Figure 1a shows  $M$  in  $\mathcal{G}(\mathbf{Z}^3)$ . Since  $\overline{M}$  consists of two connected components,  $\overline{M}$  cannot contain a Hamiltonian path. Hence by Lemma (4), there is no  $g$ - $L(2, 1, 1)$  colouring for  $\mathcal{G}(\mathbf{Z}^d)$  with  $g = 4d - 1$ .  $\square$

We shall use the previous strategy of colouring the base-segment and translating it to fill up  $\mathcal{G}(\mathbf{Z}^d)$ . Here, for the  $i^{\text{th}}$  dimension,  $t_i = 4i - 1$  and The base-segment is the set of vertices  $(x_0, 0, \dots, 0)$  with  $0 \leq x_0 \leq 4d - 1$ . The base-segment is coloured using the function:

$$f(x_0) = \begin{cases} x_0 \text{ div } 4 & x_0 \text{ mod } 4 = 0, \\ d + (x_0 \text{ div } 4) & x_0 \text{ mod } 4 = 2, \\ 2d + 1 + (x_0 \text{ div } 4) & x_0 \text{ mod } 4 = 3, \\ 3d + 1 + (x_0 \text{ div } 4) & x_0 \text{ mod } 4 = 1. \end{cases} \quad (7)$$

We now define the colouring scheme  $C_4$ , and later prove that it optimally colours  $\mathcal{G}(\mathbf{Z}^d)$ :

$$\begin{aligned} C_4(x_0, \dots, x_i, 0, \dots, 0) &= C_4(x_0 - (4i - 1)x_i, \dots, x_{i-1}, 0, \dots, 0), 1 \leq i < d \\ C_4(x_0, 0, \dots, 0) &= f(x_0 \text{ mod } 4d). \end{aligned} \quad (8)$$

We make the following observations about the colouring of the baseline:

**Lemma 6.** *For colouring the baseline,*

1. *The set of  $4d$  colours used by the function  $f$  defined in Equation (7) is  $\{0, 1, \dots, 2d - 1, 2d + 1, \dots, 4d\}$ .*
2. *The difference in colours assigned to consecutive vertices (vertices differing in  $x_0$  by 1) is at least two.*
3. *For distinct vertices  $u$  and  $v$  in the same base-segment,  $f(u) \neq f(v)$ .*  $\square$

**Lemma 7.** *On the baseline, the following is true about vertices that are assigned consecutive colours:*

1. *If they are assigned the colours  $2d + 3$  and  $2d + 4$ , then they are 2 apart.*
2. *If they are not assigned the colours  $2d + 3$  and  $2d + 4$ , then they are  $4k$  apart, where  $k \neq 0, k \in \mathbb{I}$ .*  $\square$

Theorem 4 asserts the optimality of the colouring scheme  $C_4$ ; the proof for Theorem 4 is similar to the proof of Theorem 3 above.

**Theorem 4**  $C_4$  is an optimal  $L(2, 1, 1)$  colouring of  $\mathcal{G}(\mathbf{Z}^d)$ .  $\square$

#### 4.5 Colouring Schema for $\mathbf{Z}^d$

A *colouring schema* for  $\mathbf{Z}^d$  is a generalized scheme for  $L(\delta_1, \mathbf{1}_{\sigma-2})$  colourings of  $\mathcal{G}(\mathbf{Z}^d)$  for all  $d$  and odd values of  $\sigma$ . We show the existence of such schema and present a provably-correct algorithm that uses such a colouring schema for  $\mathbf{Z}^d$ , for colouring  $\mathcal{G}(\mathbf{Z}^d)$ .

**Definition 1** For  $d \geq 1$ , suppose  $\sigma > 1, N \geq n(\sigma, d)$  are odd integers, and  $T = \langle t_1, t_2, \dots, t_{d-1} \rangle$  is a non-decreasing sequence of  $(d-1)$  positive, odd integers. Then  $(\sigma, T, N)$  is a colouring schema for  $\mathbf{Z}^d$ , denoted  $\mathcal{S}_d$ , iff

1. for each  $i, 1 \leq i < d, \sigma \leq t_i \leq N$ , and
2. for all  $X = (x_0, \dots, x_{d-1}) \in \mathbf{Z}^d, X \neq \mathbf{0}$ ,

$$\sum_{i=0}^{d-1} |x_i| < \sigma \implies \left( x_0 + \sum_{i=1}^{d-1} x_i \cdot t_i \right) \bmod N \neq 0.$$

Exhaustive verification proves the following proposition that asserts the existence of a colouring schema for  $\mathbf{Z}^3$ .

**Proposition 1** The triple given by  $\sigma = 5, T = \langle 5, 19 \rangle$ , and  $N = 27$  is a colouring schema for  $\mathbf{Z}^3$ .  $\square$

We define in Equation (9) the coloring scheme  $C_d$ , based on a colouring schema for  $\mathbf{Z}^d, \mathcal{S}_d = (\sigma, T = \langle t_1, \dots, t_{d-1} \rangle, N)$ . For each  $d$ , define a function  $g_d(x, N)$  as:

$$g_d(x, N) = \begin{cases} \frac{x}{2}, & \text{if } x \text{ is even;} \\ \frac{x+N}{2}, & \text{otherwise.} \end{cases}$$

$$C_d(x_0, 0, \dots, 0) = g_d((x_0 \bmod N), N).$$

$$C_d(x_0, x_1, \dots, x_i, 0, \dots, 0) = C_d(x_0 - x_i \cdot t_i, x_1, \dots, x_{i-1}, 0, \dots, 0). \quad (9)$$

Using properties of the colouring scheme  $C_d$ , it is easily verified that:

**Theorem 5** For  $d \geq 1$ , given  $\mathcal{S}_d = (\sigma, T = \langle t_1, \dots, t_{d-1} \rangle, N)$ , a colouring schema,  $C_d$  is an  $L(\delta_1, \mathbf{1}_{\sigma-2})$  colouring of  $\mathbf{Z}^d$  where  $\delta_1 = \frac{N-t_{d-1}}{2}$ . The span of this colouring is  $N$ .  $\square$

The following is an immediate consequence of Proposition 1 and Theorem 5.

**Corollary 1** The colouring schema for  $\mathbf{Z}^d$  given in Proposition 1 above witnesses an  $L(4, 1, 1, 1)$  colouring of  $\mathcal{G}(\mathbf{Z}^3)$ . The span of the colouring is  $N = 27$ .  $\square$

We end this section with the following observation about the efficiency of the above assignment algorithms.

**Lemma 8.** The running times of the above algorithms for colouring  $\mathcal{G}(\mathbf{Z}^d)$  are  $O(d)$ .

*Proof.* Consider the general colouring scheme  $C$  that uses the translation function  $t_i$  to colour a vertex  $P = (x_0, x_1, \dots, x_{d-1})$ . The colour assigned to  $P$  is given by:  $C(P) = C(x_0 - \sum_{i=1}^{d-1} x_i \cdot t_i, 0, \dots, 0)$ . Clearly, the assignment time is  $O(d)$ .  $\square$

## 5 Conclusions and Open Problems

We investigated relationships between channel assignments in higher dimensional square and cellular grids, colorings in higher dimensional square grids and presented optimal  $L(2, 1)$  and  $L(2, 1, 1)$  colourings for square grids in all dimensions  $d \geq 1$ . We also introduce the notion of a colouring schema for the  $d$ -dimensional square grid, and an algorithm that, given the colouring schema, assigns colours to the grid satisfying the schema constraints. Several interesting open questions arise from the work presented here. We list a few of them here: (1) Find optimal, or near-optimal, colourings for higher dimensional cellular grids. (2) Find optimal, or near-optimal, colourings for  $d$ -dimensional square grids for reuse distances larger than 4. (3) Find colouring schema  $\mathbf{Z}^d$  for various values of reuse distance and dimension.

## References

1. R. Battiti, A. A. Bertossi, and M. A. Bonuccelli. Assigning codes in wireless networks: bounds and scaling properties. *Wireless Networks*, 5:195–209, 1999.
2. Alan A. Bertossi, Cristina M. Pinotti, and Richard B. Tan. Efficient use of radio spectrum in wireless networks with channel separation between close stations. In *Proceedings of the DIAL M Workshop*, pages 18–27, 2000.
3. Alan A. Bertossi, Cristina M. Pinotti, and Richard B. Tan. Channel assignment with separation for special classes of wireless networks: grids and rings. In *Proceedings of IPDPS*, 2002.
4. Hans L. Boedlander, Ton Kloks, Richard B. Tan, and Jan van Leeuwen.  $\lambda$ -coloring of graphs. In *Proceedings of STACS*, pages 395–406, 2000.
5. J. Conway and N. Sloane. *Sphere Packings, Lattices and Groups*. Springer Verlag, second edition, 1993.
6. J. R. Griggs and R. K. Yeh. Labeling graphs with a condition at distance 2. *SIAM J. Disc. Math.*, pages 586–595, 1992.
7. W.K. Hale. Frequency assignment: Theory and application. *Proceedings of the IEEE*, 68:1497–1514, 1980.
8. Robert A. Murphey, Panos M. Pardalos, and Mauricio G.C. Resende. Frequency assignment problems. In *Handbook of Combinatorial Optimization*. Kluwer Academic Press, 1999.
9. Dayanand S. Rajan and Anil M. Shende. A characterization of root lattices. *Discrete Mathematics*, 161:309–314, 1996.