

# Development of Surface Tension Apparatus as Teaching Materials: Study lessons about Soap and Detergent at a Senior High School in Cambodia

SET seng (Okayama Univ.)  
Mie MIYOSHI (Ozukita JHS)  
Masakazu KITA (Okayama Univ.)

[Keywords] Detergent, water surface tension, capacity development of student

## 1. Introduction

In Cambodia, students have not enough chance to do the practical works such as experiments at classroom or at lab. The main reasons are of the short of appropriate teaching materials and well-trained teachers. We have developed one of the suitable teaching materials on soap and detergent, which can be conducted to Cambodian schools. Furthermore, we have conducted some lesson on this at Anuwat High School in Cambodia. We report the effectiveness of the teaching materials and study lessons.

## 2. Objectives of study lessons

The following objectives are attempted students to achieve.

- 1) Descriptions of differences and similarities between soap and detergent by observing some of their properties.
- 2) Explanation of surface tension of water phenomena and its definition.
- 3) Explanation of effect of detergent on surface tension of water as surface-active agent.
- 4) Experiment of determination of detergent amount in water sample by absorbance method.

In this presentation, we mainly report on 3).

## 3. The out line of the program

Study lessons were carried out with grade 11 students at Anuwat high school (an attached high school) located in Phnom Penh city of Cambodia as following schedule.

Date	Time/Period	Topics/Activities
21 February 2005	15:00-15:55	-Pre-test -Are soap and detergent same?
	16:05-16:55	-Let's make soap and detergent molecules; and -Let's play with water strider.
22 February 2005	15:00-15:55	-Determination of effect of SDS on surface tension of water by observing weight of water drop; and -Determination of SDS amount in sample solution by using absorbance method.
	16:05-16:55	-Discussion and analysis the results of experiment. -Post-test and questionnaire

\*SDS: Sodium Dodecyl Sulfate,  $\text{CH}_3(\text{CH}_2)_{11}\text{OSO}_3\text{Na}$

## 4. Activity

Before introducing the activity about the effect of SDS on surface tension of water, some of relevant activities are also introduced to brainstorm students such as the demonstration of "water strider" for water surface tension.

The effect of SDS on surface tension of water is simply determined by weighting water drop. 10 drops of a water sample is dropped by syringe into a dried Erlenmeyer flask which already known the weight. Then, the flask is weighed again. Therefore, weight of a drop of water can be calculated. The same procedure is carried out for other samples which contained different concentrations of SDS. Moreover, to provide students the experience in measurement of SDS concentration in sample solution, SDS concentration in each sample is not told to students. Therefore, students have to do further experiment to measure those concentrations of SDS by using absorbance method. After that, the calibration showing the relationship between weights of a drop water sample and SDS concentrations are plotting.

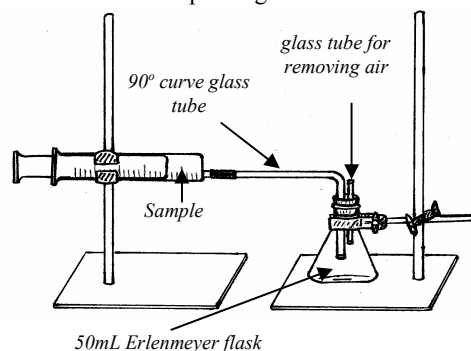

The experiment resulted by students is illustrated followed.

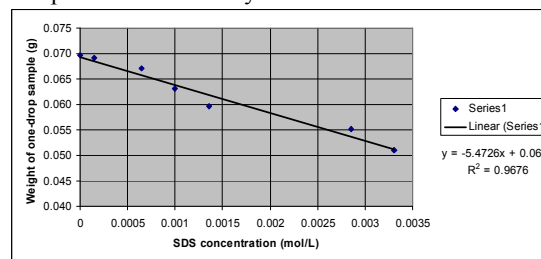

## 5. Discussion

As we know, SDS is a surface-active agent that can reduce surface tension of water. The result, water drops decrease in weight significantly while the SDS concentrations increase as seen above calibration. That means this method can be applied for detergent analysis in sample water and same as for one of environmental analysis.

Conclusively, according to experiment results and feedbacks collected from students, study lessons are highly evaluated in terms of capacity development of students, especially the objectives of study lessons seem to be achieved. At the same time, the effectiveness of teaching materials which used throughout study lessons also seems to be able to evaluate positively and appropriately to use at high schools in order to develop students' capacity in science, not only in Cambodian but also other developing countries.