



*ELECTRONIC AND AVIONICS SYSTEMS*

***INSTALLATION MANUAL***

***BENDIX/KING®***

***KMA 24***

*AUDIO PANEL/MARKER  
BEACON RECEIVER*

*MANUAL NUMBER 006-00180-0001  
REVISION 1 JANUARY, 1982*

### **WARNING**

Information subject to the export control laws. This document, which includes any attachments and exhibits hereto, contains information subject to International Traffic in Arms Regulation (ITAR) or Export Administration Regulation (EAR) of 1979, which may not be exported, released or disclosed to foreign nationals inside or outside the U.S. without first obtaining an export license. Violators of ITAR or EAR may be subject to a penalty of 10 years imprisonment and a fine of \$1,000,000 under 22 U.S.C. 2778 or Section 2410 of the Export Administration Act of 1979. Include this notice with any reproduced portion of this document.

### **COPYRIGHT NOTICE**

©1996 AlliedSignal, Inc.

Reproduction of this publication or any portion thereof by any means without the express written permission of AlliedSignal Commercial Avionics Systems is prohibited. For further information contact the Manager, Technical Publications, AlliedSignal Commercial Avionics Systems, 400 North Rogers Road, Olathe, Kansas, 66062. Telephone: (913) 782-0400.

## TABLE OF CONTENTS

### SECTION I GENERAL INFORMATION

Paragraph		Page
1.1	Introduction	1-1
1.2	Equipment Description	1-1
1.3	Technical Characteristics	1-3
1.4	Units and Accessories Supplied	1-4
1.5	Accessories Required but Not Supplied	1-5
1.6	License Requirements	1-5

### SECTION II INSTALLATION

2.1	General Information	2-1
2.2	Unpacking and Inspecting Equipment	2-1
2.3	Installation Procedures	2-1
2.3.1	Avionic Cooling Requirements For Panel Mounted Equipment	2-1
2.3.2	Mounting Rack Installation	2-1
2.3.3	Antenna Installation	2-2
2.3.4	Cable Harness and Connector Assembly	2-2
2.3.4.1	Molex Connector Assembly	2-2
2.3.5	KMA 24 Installation	2-3
2.4	Post Installation Check	2-3

### SECTION III OPERATION

3.1	KMA 24 Operation	3-1
3.1.1	Marker Beacon Receiver	3-1
3.1.2	Isolation Amplifiers	3-1

### LIST OF ILLUSTRATIONS

Figure		Page
1-1	KMA 24 Panel Combinations	1-2
2-1	Molex Terminal and Tools (3 sheets)	2-4
2-2	Outline and Mounting Drawing	2-7
2-3	Installation Assembly	2-9
2-4	KA 23 Antenna Outline and Mounting Drawing	2-11
2-5	KMA 24 Pin Functions	2-13
2-6	KMA 24 Interconnect 00 and 01	2-15
2-6	KMA 24 Interconnect 02 and 03	2-17
2-7	KMA 20 Replacement Pin Functions (2 sheets)	2-19



KING  
KMA 24  
AUDIO PANEL/MARKER BEACON RECEIVER

## SECTION I GENERAL INFORMATION

### 1.1 INTRODUCTION

This manual contains information on the mechanical and electrical characteristics of the King Radio Corporation KMA 24 Audio Panel with Marker Beacon Receiver.

### 1.2 EQUIPMENT DESCRIPTION

The KMA 24 is a compact, fully TS0'd solid state unit containing a pushbutton audio selector panel, speaker and headphone isolation amplifiers, and a marker beacon receiver. The unit has a low 1.3 inch profile for minimum panel area requirements. The KMA 24 is styled to harmonize with the other King Radio Silver Crown units but can also be efficiently integrated into any 500 ohm output audio system.

KMA 24 models are available with or without the AUTO selection feature. Customers with installations using comm transceivers without a frequency transfer (KX 170 series) will prefer the AUTO feature. Those with comm transceivers with a frequency transfer (KY 196) will likely prefer the added flexibility of an extra audio input.

Figure 1-1 shows each of the audio panel combinations available. The choice is between a third MIC function that can be either HF or TEL, and between AUTO and a second ADF.

As many as three transceivers and six receivers including the internal marker beacon receiver can be controlled by the KMA 24. The unit also has two unswitched inputs for use as altimeter warning and telephone ringer. The KMA 24 has outputs for ramp hailer and passenger address, or intercom as desired. An 8 ohm tap is provided on the secondary of the audio output transformer to provide maximum power transfer in installations using 8 ohm speakers.

Separate isolation amplifiers are provided for headphones and speaker to provide isolation even when the same source is selected for both headphones and speaker. Aircraft power for the headphones and speaker isolation amplifiers is derived from separate sources to provide a high degree of audio integrity. Power to the speaker amplifier can be switched off from the front panel but the headphone amplifier is always on. The speaker output is muted when the MIC key is pressed to transmit. In the INT (Internal or Intercom as applicable) and EXT MIC selector modes, all the audio inputs are muted to the speaker while the microphone is keyed. A PA mute output is provided to mute passenger background music systems in the INT MIC selector position.

Three isolated 16 ohm resistors are provided for transceiver speaker output loads.

The KMA 24 Marker Beacon Receiver presentation uses three colored lenses (white, blue, and amber) with the letter designations A-0-M engraved on the lens for visual station passage indication. In addition, the appropriate marker audio tone can be selected. HI-LO sensitivity and lamp test may be selected on pushbuttons adjacent to the marker beacon lights. Provision is made for driving remote marker beacon lights such as those in the King KI 285 Autopilot Annunciator Panel or KA 40 Remote Marker Beacon light display. KMA 24 Marker Beacon lights are automatically dimmed to compensate for ambient cockpit lighting conditions.

The KMA 24 will operate from either 14VDC or 28VDC aircraft power systems with no wiring changes required. The panel lighting (other than the marker beacon lights) is powered by the aircraft light dimmer buss. Both 14VDC or 28VDC light dimmer systems are accommodated by installation wiring options.

KING  
KMA 24  
AUDIO PANEL/MARKER BEACON RECEIVER

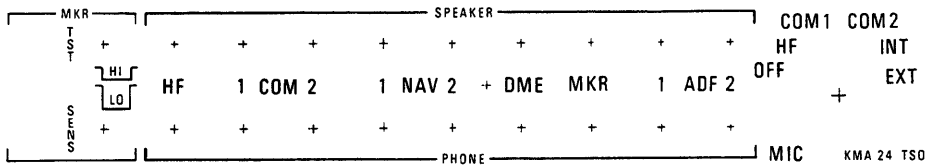

066-1055-00

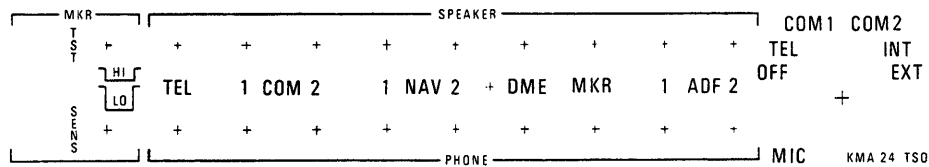

066-1055-01



066-1055-02



066-1055-03

FIGURE 1-1 KMA 24 PANEL COMBINATIONS

KING  
KMA 24  
AUDIO PANEL/MARKER BEACON RECEIVER

### 1.3 TECHNICAL CHARACTERISTICS

GENERAL

SPECIFICATION	CHARACTERISTIC
<b>TSO COMPLIANCE:</b>	
<b>MARKER BEACON RECEIVER:</b>	TSO C35d, Class A Env. Cat. /A1D1/A/PKS/XXXXXXZBAAA
<b>AUDIO AMPLIFIER:</b>	TSO C50b Env. Cat. /A1D1/A/PKS/XXXXXXZBAAA
<b>APPLICABLE DOCUMENTS:</b>	RTCA D0-143, D0-78A, D0-160
<b>WEIGHT:</b>	1.7 LBS (0.77 kgm)
<b>PHYSICAL DIMENSIONS:</b>	Length behind panel: 6.81 in. (17.30 cm) Height: 1.3 in (3.30 cm) Width: 6.25 in. (15.88 cm)
<b>DESIGN:</b>	All solid state
<b>CONTROL:</b>	Panel mounted. All operating controls are on the front panel of the unit.
<b>DUTY CYCLE:</b>	Continuous
<b>POWER REQUIREMENTS:</b>	14V <span style="float: right;">28V</span>
KMA 24 idle with MIC switch off:	less than 8mA <span style="float: right;">less than 16mA</span>
KMA 24 idle current:	110mA <span style="float: right;">170mA</span>
KMA 24 max operating current: (with 3 internal and 3 external marker lamps illuminated)	1.9 AMPS <span style="float: right;">1.9 AMPS</span>
Instrument lights:	360mA <span style="float: right;">180mA</span>
<b>TEMPERATURE RANGE:</b>	-20°C to +55°C with short time operation at +70°C.
<b>POWER OFF FUNCTION:</b>	Removes power from speaker amplifier and marker beacon receiver but not from headphone amplifier
<b>MARKER BEACON RECEIVER</b>	
SPECIFICATION	CHARACTERISTIC
<b>FREQUENCY:</b>	Crystal-controlled at 75MHz
<b>SENSITIVITY:</b>	LO 1000uV hard HI 200uV hard
<b>SELECTIVITY:</b>	6dB at +10KHz min 40dB at +200KHz max
<b>INPUT IMPEDANCE:</b>	50 ohm
<b>OUTPUT:</b>	Capable of 4 milliwatts into isolation amplifier input of 500 ohms
<b>EXT LAMP OUTPUT:</b>	125mA max each bulb

KING  
KMA 24  
AUDIO PANEL/MARKER BEACON RECEIVER

ISOLATION AMPLIFIERS

SPECIFICATION	CHARACTERISTIC
INPUTS:	Models without the AUTO function accommodate three transceivers and five external receivers. Models with the AUTO function accommodate three transceivers and four external receivers. In addition, all models have an internal marker receiver and two unswitched inputs.
INPUT SELECTOR SWITCHES:	Each switched audio input has two switches associated with it - one for speaker and one for headphones. Each switch has two positions; on and off.
INPUT IMPEDANCE:	500 ohms
INPUT ISOLATION:	40dB between inputs
INPUT MUTING:	At least 55dB when the mic is keyed.
SPEAKER OUTPUT: With 13.75V supply:	Into 4 ohm load: 7 watts Into 8 ohm load: 4 watts
With 27.5V supply:	Into 4 ohm load: 12 watts Into 8 ohm load: 6.5 watts
HEADPHONE OUTPUT:	50 milliwatts into 500 ohm load
DISTORTION:	Less than 5% at rated output
FREQUENCY RESPONSE:	Within 6dB from 350Hz to 6000Hz

## 1.4 UNITS AND ACCESSORIES SUPPLIED

A. King KMA 24 (KPN 066-1055-0X)

See Figure 1-1 to identify the last digit in the part number.

B. KMA 24 Installation Kit (KPN 050-1780-00/02)

This installation kit is provided with each unit and consists of the following:

<u>SYMBOL</u>	<u>PART NUMBER</u>	<u>DESCRIPTION</u>	<u>QUANTITY</u>
P241	008-0041-00	Lug Solder Dual	1
	030-1094-58	Conn 44 Pin	1
	030-1107-46	Pins	1
	047-4940-02	Mounting Rack	1
	089-2013-37	Nut Hex 6-32	2
	089-2191-22	Nut Hex 6-32	2
	089-2353-01	Clip Nut 6-32	6
	089-5903-07	Screw PHP 4-40 7/16	2
	089-5907-08	Screw PHP 6-32 1/2	2
	089-6012-08	Screw FHP 6-32 1/2	6
	091-0072-03	P-Clip Adj	1



KING

KMA 24  
AUDIO PANEL/MARKER BEACON RECEIVER

**1.5 ACCESSORIES REQUIRED, BUT NOT SUPPLIED**

- A. A standard type (50 ohm) Marker Beacon Antenna such as the King KA 23 (KPN 071-0121-00) and cable (RG-58A/U)
- B. Speakers as required (4 or 8 ohm desirable)
- C. Headphones (500 ohm impedance desirable)
- D. Microphones
- E. Interconnect Wiring

**1.6 LICENSE REQUIREMENTS**

None



## SECTION II INSTALLATION

### 2.1 GENERAL INFORMATION

This section contains interconnect diagrams and mounting dimensions as well as suggestions and other information pertaining to installation. The KMA 24 installation will vary somewhat depending on equipment configuration, type, location, and other factors. Cable harnesses will be fabricated by the installing agency to suit the various needs.

### 2.2 UNPACKING AND INSPECTING EQUIPMENT

Exercise extreme care when unpacking the equipment. Make a visual inspection of the unit for evidence of damage incurred during shipment. If a claim for damage is to be made, save the shipping container to substantiate the claim. The claim should be promptly filed with the transportation company. It would be advisable to retain the container and packaging material after all equipment has been removed in the event that equipment storage or reshipment should become necessary at a later date.

### 2.3 INSTALLATION PROCEDURES

#### NOTE

See Figure 2-5 before wiring cable harness.

#### NOTE

If all the speakers in an installation are 8 ohm, then F202 should be changed to the 8 ohm position. If any of the speakers are 4 ohm then F202 should be left in the 4 ohm position.

The KMA 24 may be rigidly mounted in any location with adequate area for the front panel and depth behind the panel for the unit, connector, and wiring harness. However, since the KMA 24 is shorter than a transceiver, it is normally mounted at the top of a stack of radios. The sloping top at the rear of the KMA 24 promotes this "top of the stack" installation.

#### 2.3.1 AVIONICS COOLING REQUIREMENTS FOR PANEL MOUNTED EQUIPMENT

The greatest single contributor to increased reliability of all modern day avionics is to limit the maximum operating temperature of the individual units. While modern day individual circuit designs consume much less electrical energy, the watts per cubic inch dissipated within avionics units remains much the same due to high density packaging techniques utilized. Consequently, the importance of providing avionics stack cooling is still with us.

While each individual unit may not required forced air cooling, the combined heat load of several units operating in a typical avionics stack will significantly degrade the reliability of the avionics if provisions for stack cooling are not incorporated in the initial installation. Recommendations on stack cooling are contained in King Radio Installation Bulletin #55. Failure to provide stack cooling will certainly lead to increased avionics maintenance costs and may void the King Warranty.

#### 2.3.2 MOUNTING RACK INSTALLATION

- A. Make the panel cutout as shown in Figure 2-2.
- B. Mark, punch, and drill the holes for the mounting rack. See Figure 2-2 for the hole locations.
- C. Secure the mounting rack to the instrument panel. The rear of the rack should be attached to the airframe by means of support brackets.

KING  
KMA 24  
AUDIO PANEL/MARKER BEACON RECEIVER

### 2.3.3 ANTENNA INSTALLATION

The antenna should be mounted on a flat surface on the underside of the aircraft fuselage near the centerline of the aircraft. The antenna centerline should be parallel to the aircraft centerline. Avoid locations close to high power antennas.

Mount the KA 23 with two #10-32 x 5/16 machine screws. See Figure 2-4 for KA 23 mounting dimensions.

### 2.3.4 CABLE HARNESS AND CONNECTOR ASSEMBLY

The KMA 24 uses a special connector that mates directly with the printed circuit board inside the unit. A plastic cable tie is provided in the installation kit to provide strain relief and can be installed on either side of the mounting rack to route the cable harness either direction.

### NOTE

Some of the KMA 24 pin functions vary depending on the flavor of the unit. See Figure 2-5. Be sure to use the correct interconnect drawing for the unit being installed (Figures 2-6 and 2-6A).

How and where grounds are tied together is very important in an audio panel installation. It is desirable for all audio grounds to come together at one common point and this common point should be inside the audio amplifier. Ideally twin shielded lead wire should be used for all 500 ohm audio lines from radios that have separate audio grounds and single lead shielded wire should be used for all other 500 ohm audio lines. In all cases the shield on these lines should be grounded on the load end only (the KMA 24 end). The interconnect drawings indicate the use of shielded wire. Unshielded wire can be used for these audio lines, however noise immunity and isolation between audio inputs will suffer accordingly.

Speaker and headphone ground return lines are also desirable but when used should be kept separate from all other grounds and connected to pin 22 on the KMA 24 rear connector. Pin 2 of the KMA 24 should be connected directly to the airframe with a short heavy wire (at least #18AWG). All other grounds should be connected to pin 1 of the KMA 24. A solder lug is provided on the rear of the KMA 24 installation rack to be used as a collection point for all grounds that are to be connected to pin 1. If shielded wire is used for the audio inputs, the shields should all be tied together and kept separate from the audio grounds until they are brought together at the solder lug.

The two power input lines should be supplied through separate circuit breakers or fuses in the aircraft. Pin 7 supplies power to the headphone amplifier while pin 20 supplies power to the speaker amplifier and marker receiver. Separate circuits will therefore prevent the total loss of audio if one circuit should open.

### NOTE

Many transceivers have a 4 ohm output for driving a cabin speaker. These outputs must be terminated with the speaker loads provided in the KMA 24.

#### 2.3.4.1 Molex Connector Assembly (Figure 2-1)

- a. Solderless Contact Terminal Assembly using Molex Crimper

Refer to instructions in Figure 2-1.

- b. Solderless Contact Terminal Assembly using Pliers

- (1) Strip each wire 5/32" for contact terminal (KPN 030-1107-XX). (The last two digits of the contact terminal part number indicate the number of terminals furnished).
- (2) Tin the exposed conductor.

KING  
KMA 24  
AUDIO PANEL/MARKER BEACON RECEIVER

- (3) Using needle nose pliers, fold over each conductor tab in turn, onto the exposed conductor. When both tabs have been folded, firmly press the tabs against the conductor.
  - (4) Repeat step 3 for insulator tabs.
  - (5) Apply a small amount of solder (using minimum heat) to the conductor/tab connection to assure a good electromechanical joint.
- c. Contact Insertion into Molex Connector Housing
- (1) After the contact terminals have been installed on the wiring harness, the contact terminals can be inserted into the proper location in the connector housing (KPN 030-1094-53). The terminal cannot be inserted upside down. Be sure to push the terminal all the way in, until a click can be felt or heard.
  - (2) The self-locking feature can be tested by gently pulling on the wire.
- d. Extraction of Contact from Molex Connector
- (1) Slip the flat narrow blade of a Molex contact ejector tool, HT-1884 (KPN 005-2012-11), under the contact on the mating side of the connector. By turning the connector upside down one can see the blade slide into the stop.
  - (2) When the ejector is slid into place, the locking key of the contact is raised, allowing the contact to be removed by pulling moderately on the lead.
  - (3) Neither the contact or position is damaged by removing a contact; however, the contact should be checked visually before reinstalling in connector, to be certain that retaining tab "A" extends as shown (see Figure 2-1) for retention in connector.

### 2.3.5 KMA 24 INSTALLATION

#### NOTE

- A. Slide the unit into the mounting rack until the locking screw contacts the rear of the mounting rack.
- B. Insert a 3/32" Allen wrench through the hole in the front panel and turn clockwise until the unit is secure in the mounting rack. Do not overtighten.
- C. For removal, turn the locking screw counter-clockwise until the unit disengages from the mounting rack.

### 2.4 POST INSTALLATION CHECK

#### CAUTION

BEFORE FLIGHT TEST CHECK ALL AIRCRAFT CONTROL MOVEMENTS TO ENSURE THAT WIRING HARNESES DO NOT INTERFERE WITH THEIR OPERATION.

An operation performance flight test is recommended after the installation is complete to ensure satisfactory performance of the equipment in its normal environment.

Four volume adjustments can be made through the top cover of the KMA 24:

- A. Marker audio output volume
- B. Cabin speaker volume
- C. Headphone volume
- D. Internal and external speaker and intercom volume

KING  
KMA 24  
AUDIO PANEL/MARKER BEACON RECEIVER

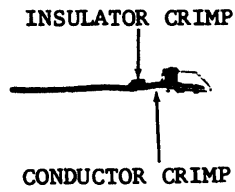

SOLDERLESS CONTACT TERMINAL  
KPN 030-1107-30

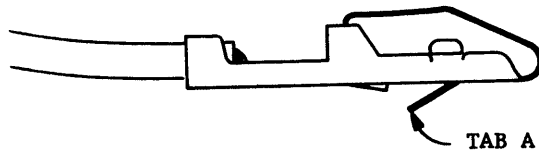

HAND EJECTOR  
KPN 047-5099-01  
MOLEX PN HT-1884

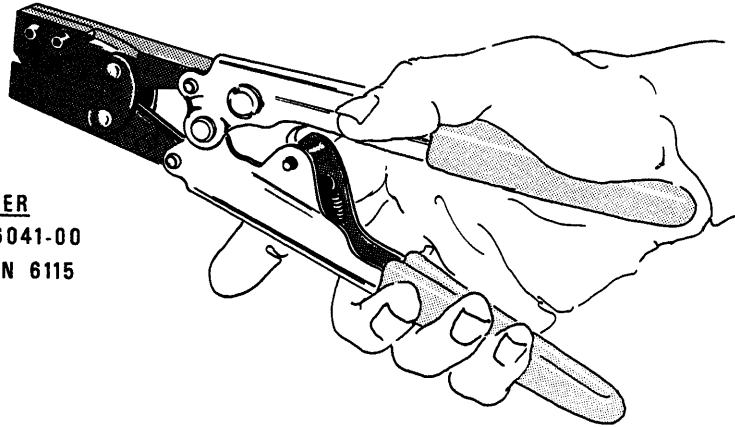

FIGURE 2-1 MOLEX TERMINAL AND TOOLS  
(Dwg. No. 696-6333-00, R-1)  
(Sheet 1 of 3)

KING  
KMA 24  
AUDIO PANEL/MARKER BEACON RECEIVER

Holding the hand crimpers as shown, release the crimper's ratchet pawl and open by squeezing tightly on the handles, and then releasing pressure.

**HAND CRIMPER**  
KPN 071-6041-00  
MOLEX P/N 6115



Close crimpers until ratchet begins to engage. Then insert the terminal into the jaws from the back side. (See Figures at bottom of page) For 24 to 30AWG wire, it will be necessary to start the crimp in jaw A and then complete it in jaw B.

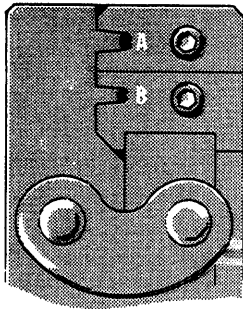

JAW	TERMINAL	WIRE SIZE	INSULATION RANGE
A	030-1107-30	18 to 24 AWG	.110 to .055
B	030-1107-30	24 to 30AWG	.055 to .030

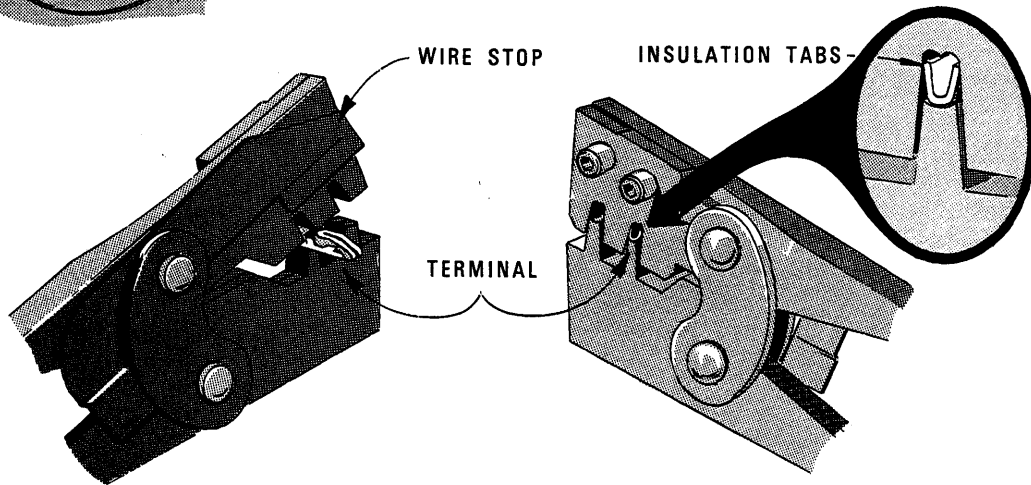

Terminal is in correct position when insulation tabs are flush with outside face of crimp jaws.

FIGURE 2-1 MOLEX TERMINAL AND TOOLS  
(Sheet 2 of 3)

KING

KMA 24  
AUDIO PANEL/MARKER BEACON RECEIVER

Once the terminal is in the correct position, close the jaws gently until the terminal is held loosely in place. Push wire stop down so that it rests snugly behind the contact portion of the terminal.

Strip the wire insulation back 1/8 inch and insert the wire through the insulation tabs into the conductor tabs until the insulation hits the conductor jaw face or until the conductor touches the wire stop.

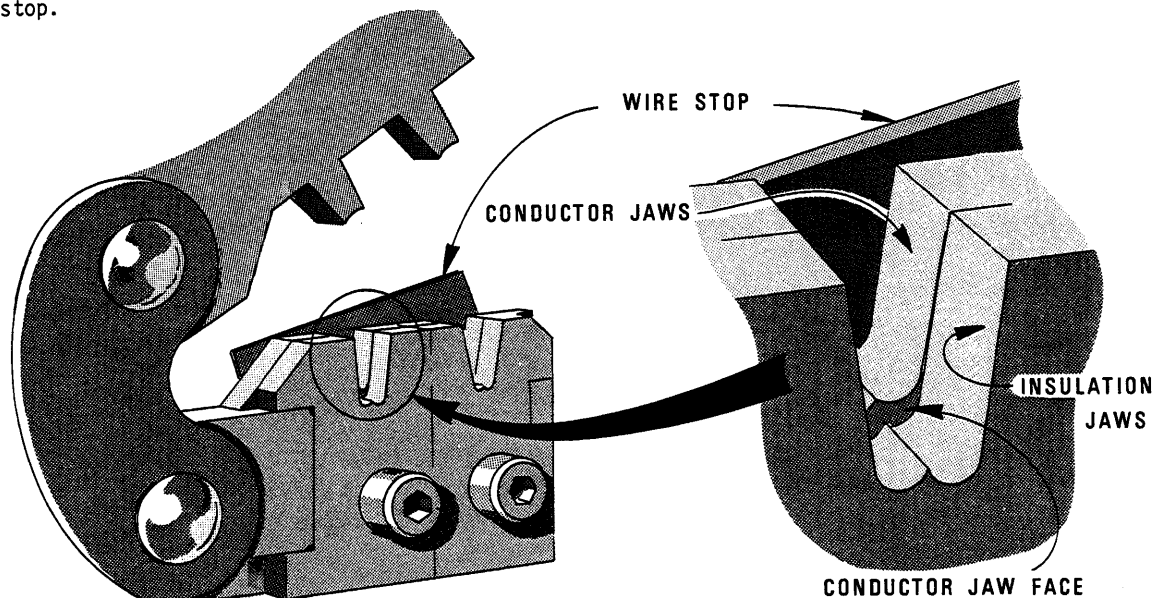

Squeeze the handles until the crimp jaws close and the ratchet releases.

Straighten the terminal if necessary, then release the plier grips and remove the crimped terminal.

CRIMPING PRESSURE ADJUSTMENT

If too much or too little pressure is needed to release the crimper's ratchet pawl at the end of the crimp stroke, the ratchet can be easily adjusted. A spanner wrench provided with the tool can be used to loosen the lock nut, and rotate the keyed stud clockwise for increased pressure and counter-clockwise for decreased pressure. Once the desired pressure has been set, the lock nut must be tightened again. Newer models may have a screwdriver adjustment.

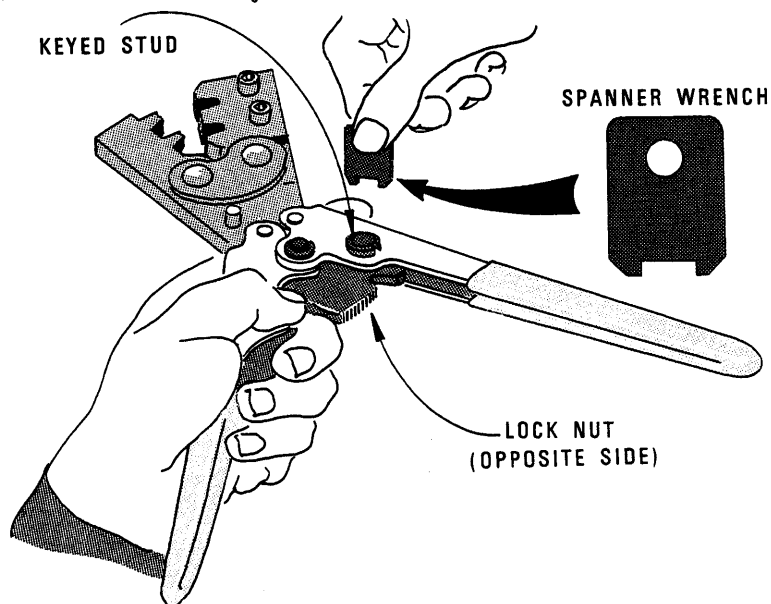
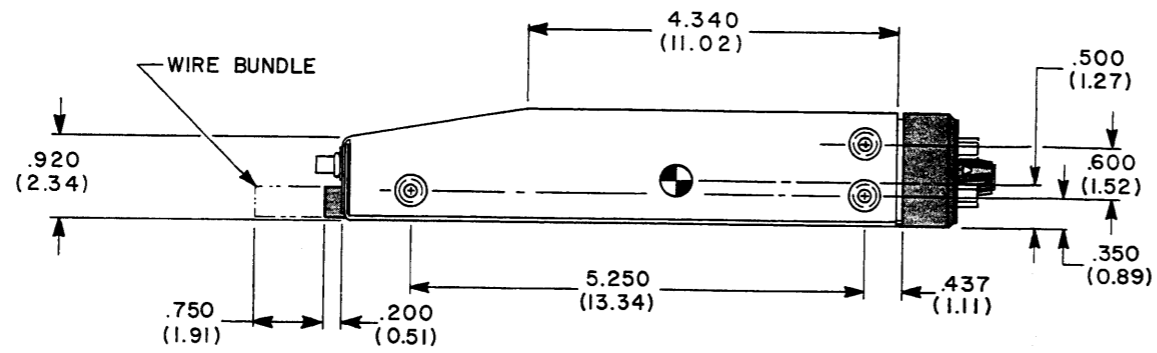

FIGURE 2-1 MOLEX TERMINAL AND TOOLS  
(Sheet 3 of 3)



KING  
KMA 24  
AUDIO PANEL/MARKER BEACON RECEIVER



SAME FOR  
KMA 24  
OR  
KMA 24H

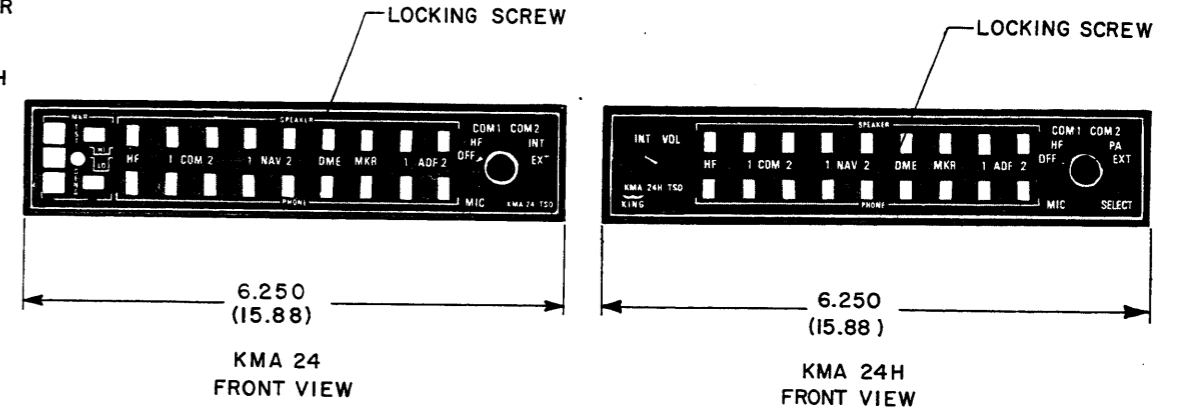

NOTES:

1. DIMENSIONS IN ( ) ARE IN CENTIMETERS.
2. WEIGHT: 1.7 LBS. (0.771 Kg.)
3. TOLERANCES FOR PANEL CUTOUTS: +.010 (+.025)  
-.000 (-.000)
4. KMA 24: 2.630 (6.68) CG, KMA 24H: 2.780 (7.06) CG.
5. KMA 24: 3.300 (8.38) CG, KMA 24H: 3.560 (9.04) CG.
6. WHEN INSTALLING TWO OR MORE PANEL MOUNTED UNITS IN A STACK, THE MOUNTING TRAYS SHALL BE SPACED .050 INCHES (.127 CM.) APART. NEWER STYLE MOUNTING TRAYS HAVE HAD .025 INCH (.063 CM.) DIMPLES BUILT IN, TOP AND BOTTOM, BOTH SIDES, SO THAT TWO NEW STYLE TRAYS WILL AUTOMATICALLY BE SPACED PROPERLY.
7. TO DETERMINE STACK HEIGHT, USE THE HEIGHT DIMENSION FOR A FRONT AIRCRAFT PANEL MOUNT.

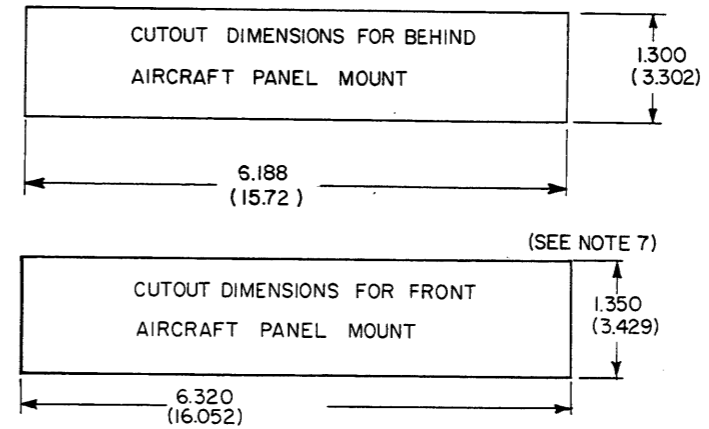
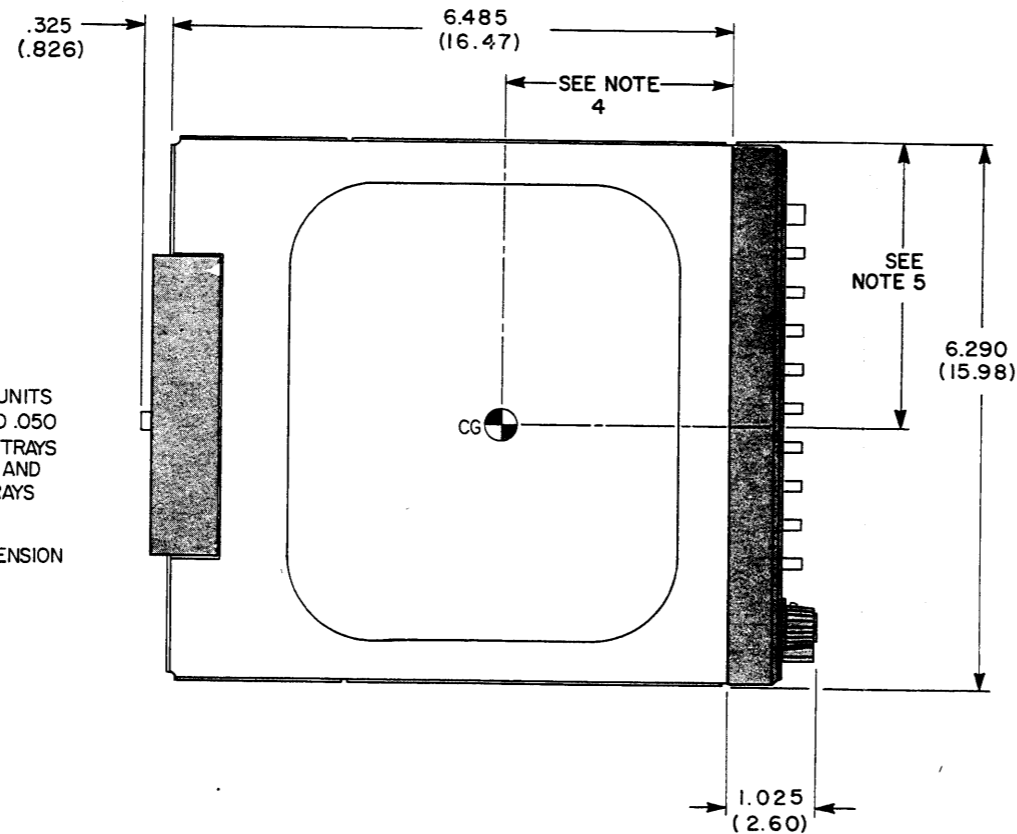

FIGURE 2-2 OUTLINE AND MOUNTING DRAWING  
(Dwg. No. 155-5321-00, R-4)

KING  
KMA 24  
AUDIO PANEL/MARKER BEACON RECEIVER

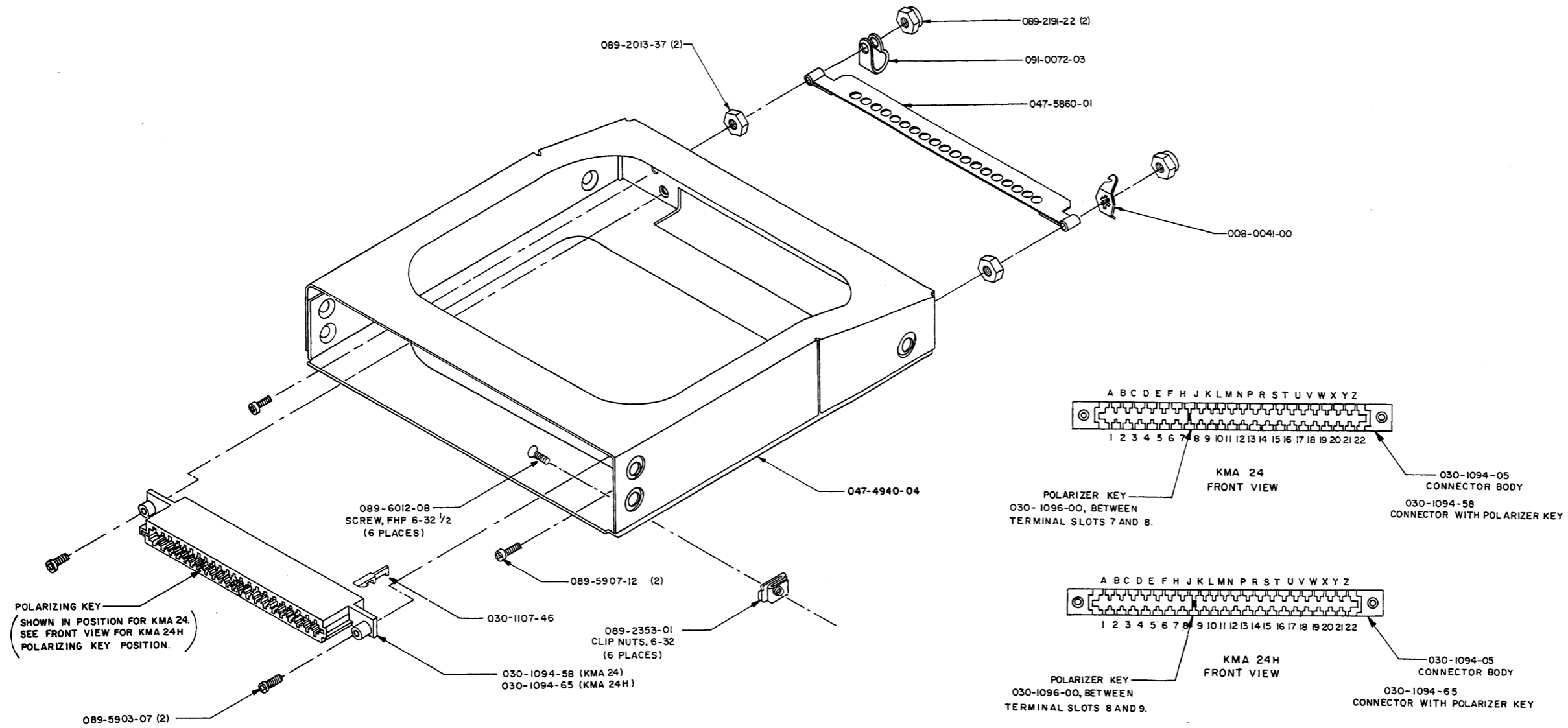

FIGURE 2-3 INSTALLATION ASSEMBLY  
(Dwg. No. 155-5322-00, R-4)

KING  
KMA 24  
AUDIO PANEL/MARKER BEACON RECEIVER

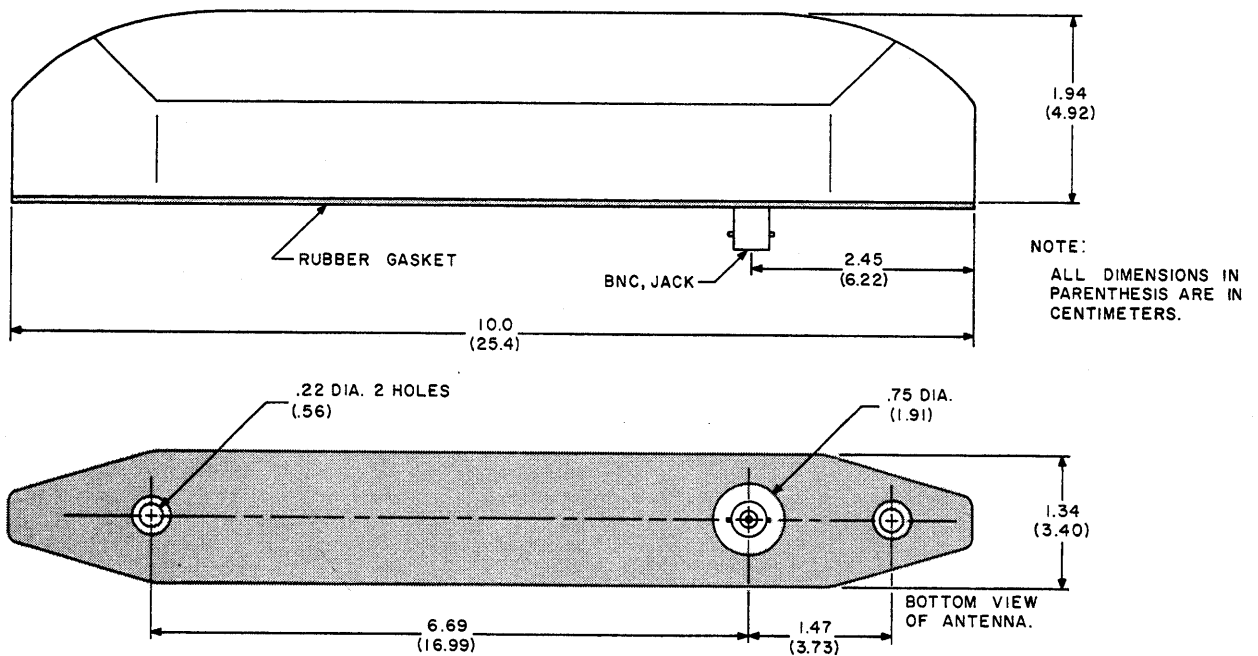

FIGURE 2-4 KA 23 ANTENNA OUTLINE AND MOUNTING DRAWING  
(Dwg. No. 696-0012-00, R-0)



KING  
KMA 24  
AUDIO PANEL/MARKER BEACON RECEIVER

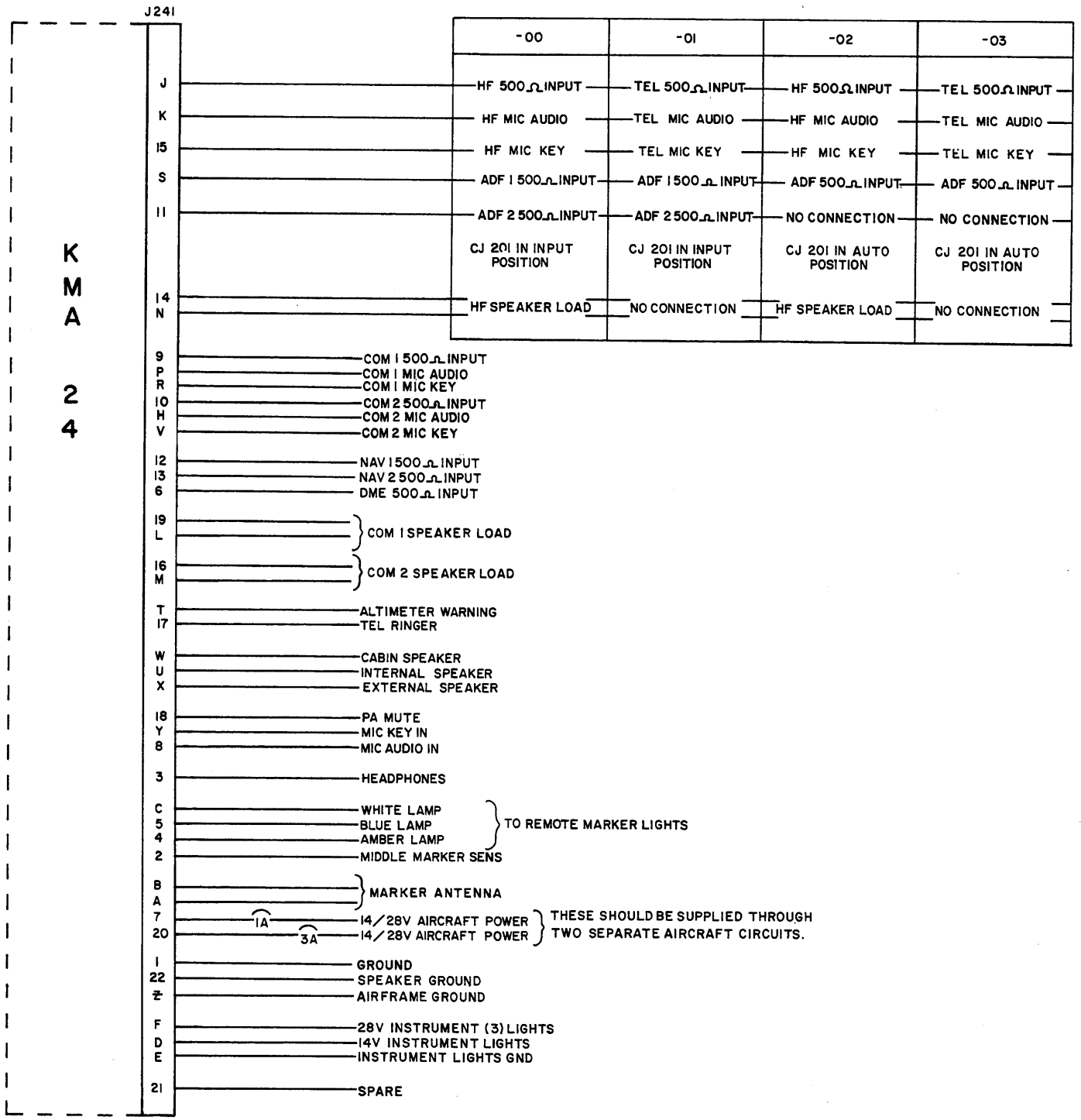
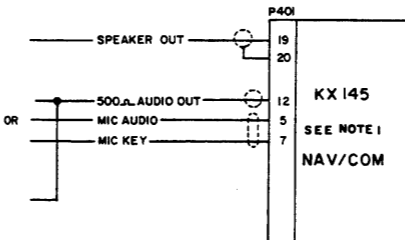
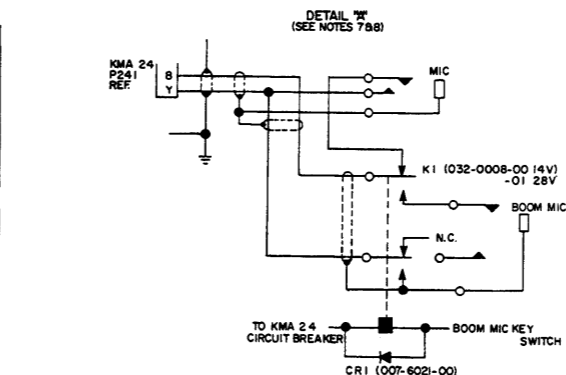
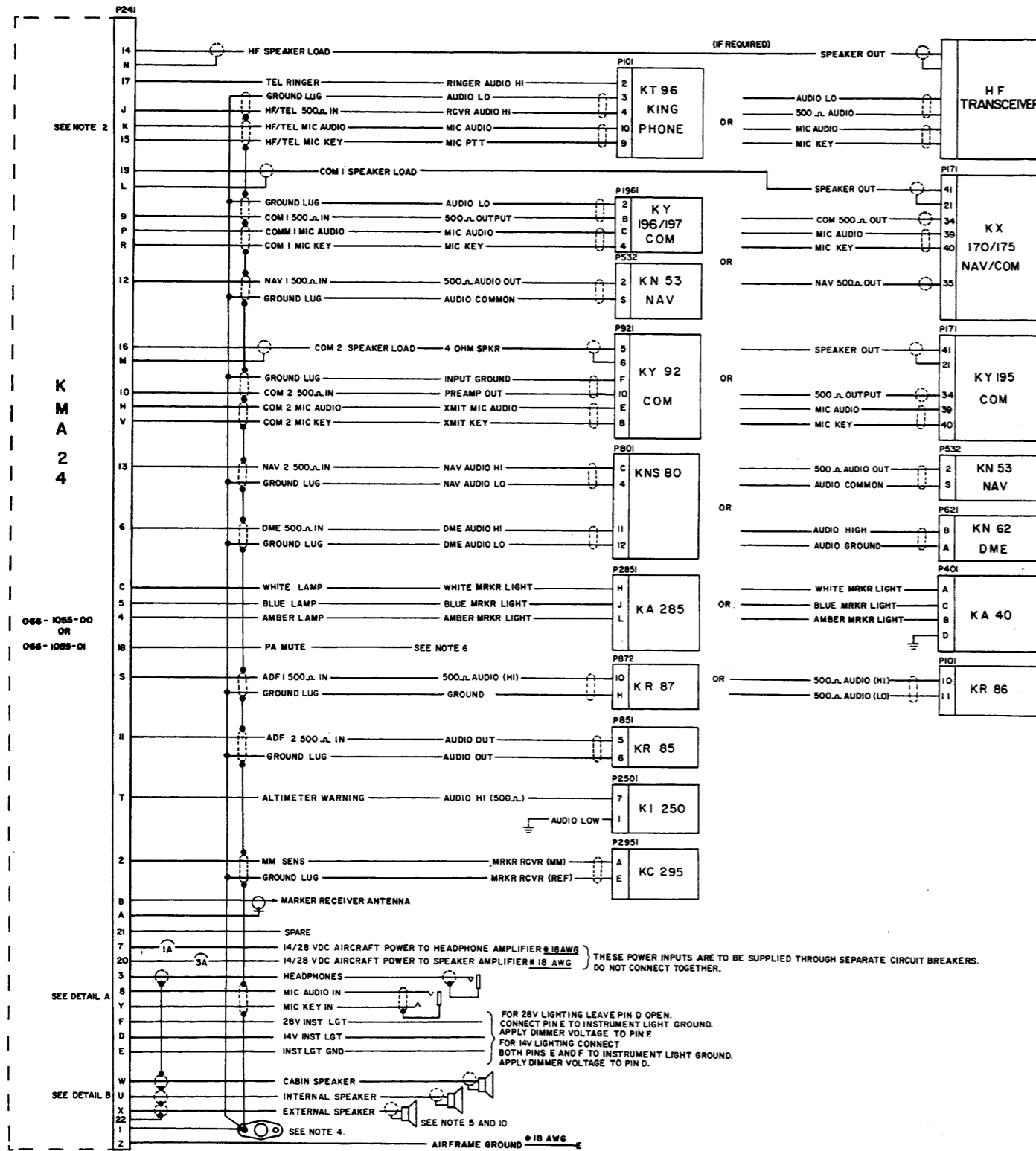

FIGURE 2-5 KMA 24 PIN FUNCTIONS  
(Dwg. No. 696-0150-00, R-0)



**KING  
KMA 24  
AUDIO PANEL/MARKER BEACON RECEIVER**



- NOTES**
1. THE KX 145 500 OHM OUTPUT IS PIN 12 BUT IF TRANSMIT SIDETONE IS DESIRED, PINS 12 & 13 OF THE KX 145 MUST BE SHORTED TOGETHER AND PIN 18 (500Ω HEADPHONE) USED AS THE 500Ω AUDIO INPUT TO THE KMA 24.
  2. PINS J, K, AND 15 ARE USED FOR HF RECEIVER CONNECTIONS ON THE -00 FLAVOR AND FOR RADIO TELEPHONE CONNECTIONS ON THE -01 FLAVOR.
  3. ALL SHIELDS SHOULD BE GROUNDED ON ONE END ONLY. THE END THAT IS GROUNDED SHOULD ALWAYS BE THE LOAD END AS SHOWN.
  4. SPEAKER AND HEADPHONE GROUND RETURNS MUST BE KEPT SEPARATE FROM OTHER GROUNDS. THEY SHOULD BE CONNECTED TO PIN 22. PIN 22 MUST BE CONNECTED TO AIRFRAME GROUND WITH A SHORT, HEAVY (#18 AWG) WIRE. ALL OTHER GROUNDS SHOULD BE CONNECTED TO PIN 1 AND THE SOLDER LUG.
  5. IF AN INTERNAL SPEAKER IS NOT USED THEN ONE OF THE 3 SPEAKER LOADS SHOULD BE CONNECTED BETWEEN PINS U AND 22. IF AN EXTERNAL SPEAKER IS NOT USED THEN THE SPEAKER LOAD SHOULD BE CONNECTED BETWEEN PINS X AND 22. IF NEITHER AN INTERNAL NOR EXTERNAL SPEAKER IS USED THEN SHORT PIN X TO PIN U AND CONNECT THIS PAIR TO ONE END OF A SPEAKER LOAD AND CONNECT THE OTHER END OF THIS LOAD TO PIN 22. WHEN ALL 3 SPEAKER LOADS ARE ALREADY IN USE, AN EXTERNAL 16 OHM 3 1/4 WATT RESISTOR (KPN 132-0107-33) SHOULD BE USED TO LOAD THE INT OR EXT SPEAKER OUTPUTS AS REQUIRED.
  6. PA MUTE (PIN 18) IS AN OUT PUT FROM THE KMA 24 THAT IS PULLED LOW WHEN THE MICROPHONE IS KEYED WITH THE MIC SELECT SWITCH IN THE INT POSITION. THIS LINE CAN BE USED TO MUTE PASSENGER ADDRESS AUDIO. WHEN NOT USED, PIN 18 SHOULD BE LEFT OPEN.
  7. OPTIONAL INTERCONNECT FOR BOOM MIC OR DUAL HEADSET INSTALLATION.
  8. IF STANDARD 3-WIRE MICROPHONE PLUG IS USED, THE FRAME OF THE MIC JACK(S) SHOULD BE ISOLATED FROM GROUND BY INSULATED WASHERS TO PREVENT INTRODUCING NOISE INTO THE MIC AUDIO.
  9. FOR INTERCOM OPERATION THE MIC SELECTOR SWITCH IS PLACED IN THE "INT" POSITION AND MIC AUDIO WILL BE HEARD OVER THE HEADPHONE OUTPUT IF JUST INTERCOM OPERATION IS DESIRED. PIN U, THE INTERNAL SPEAKER OUTPUT, MUST BE TERMINATED INTO A 16ohm 3 1/4 WATT RESISTOR, KPN 132-0107-33. IF INTERCOM AND INTERNAL SPEAKER OPERATIONS ARE BOTH DESIRED, A SWITCH FOR SELECTING BETWEEN THE 2 OPERATIONS IS REQUIRED (SEE DETAIL B). THREE 16ohm 3 1/4 WATT RESISTORS ARE AVAILABLE BETWEEN PINS M AND N, IS AND L, 16 AND M, TO BE USED FOR THIS PURPOSE IF THEY ARE NOT ALREADY USED.
  10. IF ALL SPEAKERS IN INSTALLATION ARE 8 OHM F202 SHOULD BE IN 8 OHM POSITION. IF ANY SPEAKERS IN THE INSTALLATION IS 4 OHM THEN F202 SHOULD BE LEFT IN 4 OHM POSITION. (REFER TO FIG 6-2 ON PAGE 6-17 OF THE MAINTENANCE MANUAL FOR POSITIONING OF F202.)

FIGURE 2-6 KMA 24 INTERCONNECT 00 AND 01  
(Dwg. No. 155-1358-00, R-3)  
(Sheet 1 of 2)

KING  
KMA 24  
AUDIO PANEL/MARKER BEACON RECEIVER

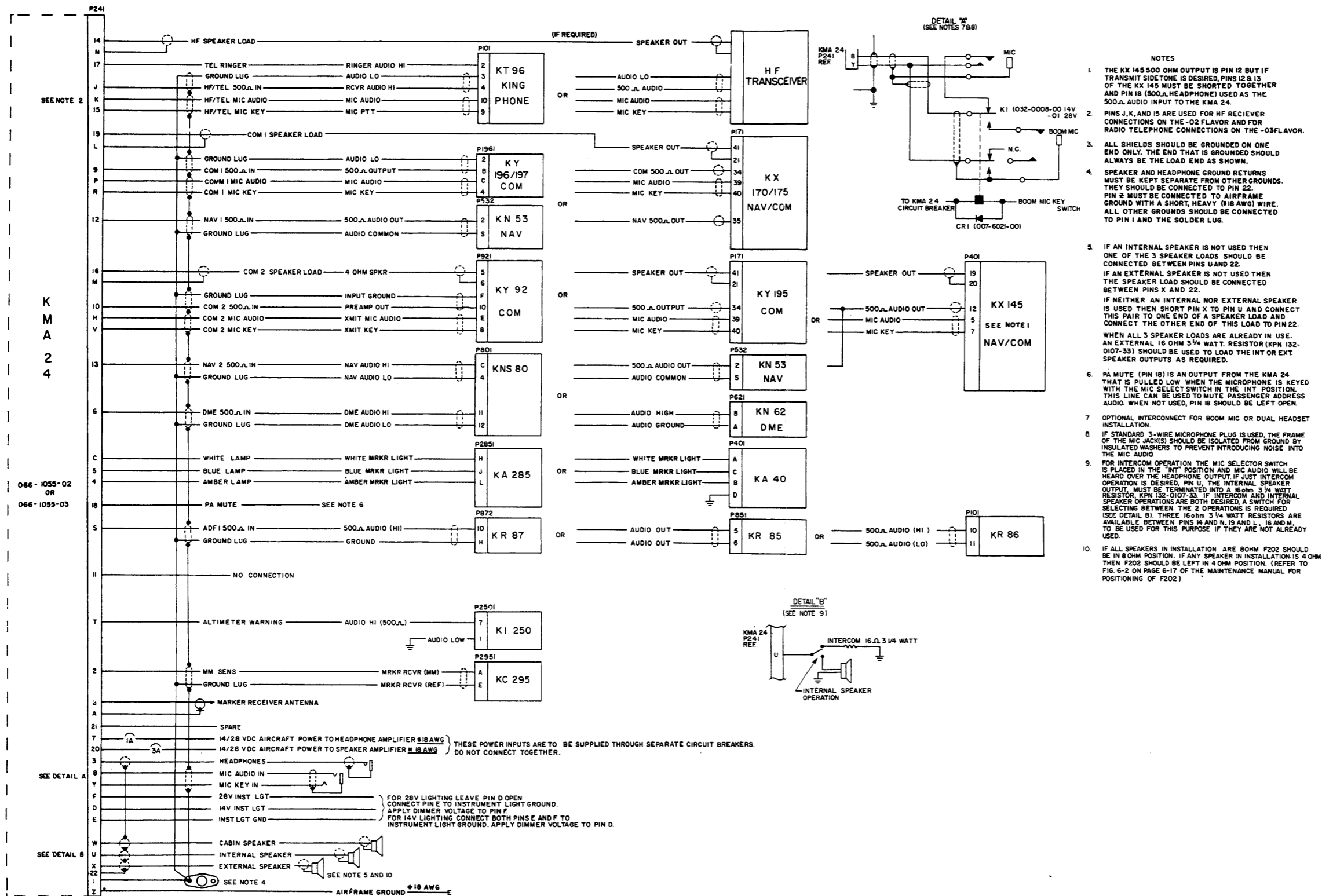

FIGURE 2-6 KMA 24 INTERCONNECT 02 AND 03  
(Dwg. No. 155-1358-00, R-3)  
(Sheet 2 of 2)



KING  
KMA 24  
AUDIO PANEL/MARKER BEACON RECEIVER

KMA 20

1	AIRFRAME GROUND
2	28V LIGHT DIMMER
3	14V LIGHT DIMMER
4	14/28V AIRCRAFT POWER
5	UNSWITCHED 500 OHM INPUT
6	COM 1 SPKR LOAD
7	COM 2 SPKR LOAD
8	AUX SPKR LOAD
9	EXTERNAL SPEAKER
10	CABIN SPEAKER
11	MIC AUDIO IN
12	HF/TEL MIC AUDIO
13	HF/TEL 500 OHM INPUT
14	COM 1 500 OHM INPUT
15	COM 2 500 OHM INPUT
16	NAV 1 500 OHM INPUT
17	MARKER ANTENNA (CENTER)
18	MARKER ANTENNA (SHIELD)
19	WHITE LAMP
20	BLUE LAMP
21	AMBER LAMP
22	P.A. SPEAKER
23	MIC KEY IN
24	HF/TEL MIC KEY
25	COM 1 MIC KEY
26	COM 2 MIC KEY
27	COM 1 MIC AUDIO
28	COM 2 MIC AUDIO
29	NAV 2 500 OHM INPUT
30	ADF/ADF 1 500 OHM INPUT
31	DME/ADF 2 500 OHM INPUT
32	HEADPHONES

KMA 24

Z	SEE NOTE 1
F	SEE NOTE 2
D	SEE NOTE 2
20	SEE NOTE 3
	SEE NOTE 4
19	SEE NOTE 5
16	SEE NOTE 5
14	SEE NOTE 5
X	SEE NOTE 6
W	
8	
K	SEE NOTE 7
J	SEE NOTE 7
9	
10	
12	
B	
A	
C	
5	
4	SEE NOTE 8
U	SEE NOTE 6
Y	
15	SEE NOTE 7
R	
V	
P	
H	
13	
S	
	SEE NOTE 9
3	

KMA 24

SPEAKER GROUND	22	
GROUND	1	
LIGHT DIMMER GROUND	E	
14/28V AIRCRAFT POWER TO HEADPHONE AMP	7	
TEL RINGER	17	
ALTIMETER WARNING	T	
COM 1 SPEAKER LOAD RETURN	L	SEE NOTE 5
COM 2 SPEAKER LOAD RETURN	M	SEE NOTE 5
AUX SPEAKER LOAD RETURN	N	SEE NOTE 5
DME 500 OHM INPUT	6	
ADF 2 500 OHM INPUT	11	SEE NOTE 9
MIDDLE MARKER SENSE	2	
P.A. MUTE	18	
SPARE	21	

FIGURE 2-7 KMA 20 REPLACEMENT PIN FUNCTIONS  
(Sheet 1 of 2)

KING  
KMA 24  
AUDIO PANEL/MARKER BEACON RECEIVER

NOTES

1. The KMA 24 has 3 separate ground pins. Pin Z is the airframe or power ground. Pin 22 should be used to ground all speaker and headphone ground returns and pin 1 should be used for all other grounds.
2. LIGHT DIMMER GROUND is a separate ground on the KMA 24 (Pin E).
3. HEADPHONE AMPLIFIER POWER is supplied by a separate pin on the KMA 24 (Pin 7).
4. The KMA 24 has 2 unswitched audio inputs: Pin 17 which is meant to be used for TELEPHONE RINGER and pin T which is meant to be used for ALTIMETER WARNING. The pin T input is not muted when the microphone is keyed.
5. Each speaker load is isolated from the KMA 24 ground. See the load return pin numbers above.
6. If either the INT (passenger address) or EXT (ramp hail) speakers is not used on the KMA 24, their outputs should be loaded with a 16 ohms, 3-1/4 watt load resistor.
7. KMA 24 pins K, J, and 15 are used for HF on the -00 and -02 versions and for TEL on the -01 and -03 versions.
8. A MIDDLE MARKER SENSE (Pin 2) is provided on the KMA 24 for connection to flight control systems. This line goes high when the middle marker is detected but not when lamp test is activated.
9. The DME 500 OHM INPUT is always pin 6 on the KMA 24. An ADF 2 input is provided on versions -00 and -01 as pin 11. However, pin 11 must be left open on versions -02 and -03 since this input is used for the AUTO function on these versions.

FIGURE 2-7 KMA 20 REPLACEMENT PIN FUNCTIONS  
(Sheet 2 of 2)

## SECTION III OPERATION

### 3.1 KMA 24 OPERATION

#### 3.1.1 MARKER BEACON RECEIVER

Marker beacon receivers are used to provide accurate fixes by informing the pilot of his passage over beacon stations located on airways and ILS approach courses. Three types of beacons are used; the inner marker, the outer marker and the middle marker. The marker beacons used to mark airways are the same as inner markers as far as the receiver is concerned.

The outer marker is normally positioned on the front localizer course near the point where the glideslope approach path intersects the minimum inbound altitude. Distance from the airport will vary from 3.5 to 6 miles. The outer marker signal is modulated at 400Hz and is keyed at the rate of two dashes per second. When passing over the outer marker, the blue light (labeled "O") will flash on/off at the rate of two per second and if the marker audio is selected by the pilot he will hear a series of low tone dashes.

The middle marker will normally be positioned about 3500 feet from the ILS runway threshold and indicates the point on the ILS glidepath that is 200 feet above the runway threshold. The middle marker signal is modulated with 1300Hz and this modulation is keyed with alternate dots and dashes. These dots and dashes will be heard in a medium pitched tone during passage over the middle marker and the amber light (labeled "M") will flash synchronously with the tones.

When the inner marker is used it will be located close to the ILS runway threshold and it will indicate an altitude of 100 feet above the threshold when following the ILS glidepath. The inner marker modulation is 3000Hz and is keyed six times per second. Passage over this marker will produce high pitch (3000Hz) dots and synchronous flashes from the white light (labeled "A").

Airway, or enroute, marker beacons are also modulated with 3000Hz. Passage over these beacons will cause a 3000Hz tone to be heard and the white light to flash.

The three marker lights can be tested by depressing the top horizontal pushbutton labeled "TST". This test can be performed at any time on the KMA 24 without disturbing a coupled autopilot.

The sensitivity of the marker beacon receiver can be selected with the bottom horizontal pushbutton labeled "SENS". With HI sensitivity selected (SENS pushbutton depressed) the receiver will detect a weaker signal than it will with LO selected. It is suggested that the HI sensitivity be selected until the outer marker aural indication is received. This should be about one mile before the outer marker. Then LO sensitivity may be selected to reduce the duration of the indication thereby obtaining a more accurate indication of station passage. The audio tones will be heard before and after the visual indication is given since a stronger signal is required for lamp illumination than for aural tone.

#### 3.1.2 ISOLATION AMPLIFIERS

The top row of vertical pushbuttons on the KMA 24 are used to select the desired audio to be heard on the cabin speaker. The bottom row of vertical pushbuttons likewise select the audio to be heard on the headphones. The selections are completely independent of each other allowing the same audio input to be selected for both speaker and headphones if desired.

The "AUTO" pushbuttons (not on some versions) when selected will cause the audio from the transceiver selected with the mic switch to be heard. Two AUTO pushbuttons are provided. One for the speaker and one for the headphones.

The microphone selector switch performs several functions. It routes microphone audio and keying to the appropriate transceiver or to the speaker amplifier in the KMA 24. It switches the speaker amplifier output to the appropriate speaker. On units with "AUTO" this function is performed by the microphone selector switch. Also, it turns the speaker amplifier power on and off.

When the mic selector switch is in the "OFF" position, power is not supplied to the speaker amplifier or to the marker receiver. However, the headphone amplifier will still be active.

KING

KMA 24  
AUDIO PANEL/MARKER BEACON RECEIVER

The "INT" position of the mic selector switch will provide either an internal speaker other than the cabin speaker (passenger address) or intercom. If an internal speaker is used it should be remotely located to prevent feedback between this speaker and the microphone. A "PA mute" is provided which can be used to mute the normal passenger address audio while the microphone is keyed in the "INT" position.