

# Pumps & Motors

<b>Series Overview</b> .....	156 - 157
<b>Pump and Motor Displacement Chart</b> .....	158 - 159
<b>General Product and Safety Information</b> .....	160
<b>Torque Requirements &amp; Overhang Data</b> .....	161

## Geroter Motors & Pumps

- Series MGG Motors ..... 163 - 167
- Series PGG Pumps ..... 169 - 173

## Vane Pumps

- Series TB ..... 175, 178 - 179
- Series TC ..... 176, 178 - 179
- Series DCB ..... 177 - 179

## Gear Pumps & Motors

- Series P16 ..... 181 - 184
- Series TP16 (two-place) ..... 185 - 188
- Series TP16 (three-place) ..... 189 - 192
- Series PVP16 ..... 193 - 197
- Series CP16 ..... 199 - 202
- Series DP16 Dump Pumps ..... 203 - 206
- Series 20 ..... 207 - 209
- Series R20 ..... 211 - 214
- Series M20 ..... 215 - 217
- Series TP20 (two-place) ..... 219 - 221
- Series TP20 (three-place) ..... 223 - 226
- Series NST20 ..... 227 - 230
- Series NSD20 ..... 231 - 234
- Series NDS20 ..... 235 - 238
- Series SPM20 ..... 239 - 241

<b>Gresen Repair Parts</b> .....	493 - 505
----------------------------------	-----------

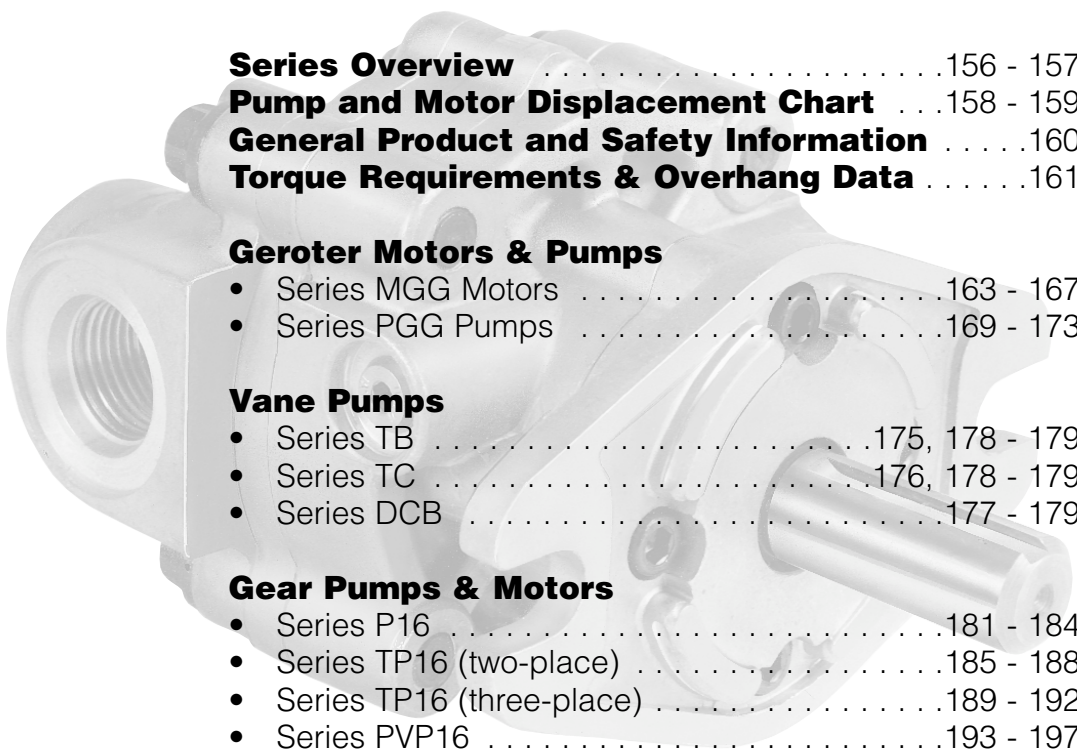

# Geroter Series

**FEATURES:**

- Geroter design (High Speed/Low Torque)
- Aluminum construction for optimum power to weight ratio
- Bi-directional
- High pressure mechanical seals available for series application to 1000 PSI back pressure
- Journal bearings for long life
- Buna-N Seals are standard for petroleum and glycol based fluids "Viton" seals are optional.

**Series Description****Page**

**MGG** - Motor ..... **163 - 167**



**PGG** - Pump ..... **169 - 173**

# Vane Pump Series

**FEATURES:**

- Fully balanced vane pumps
- No load starting
- High efficiency
- Four position inlet
- Optional size port openings
- Light weight aluminum housing
- Optional rotation
- Anti-friction main bearing

**Series Description****Page**

**TB** ..... **175, 178 - 179**



**TC** ..... **175, 178 - 179**









**DCB** ..... **177 - 179**

## Series P16

### FEATURES:











- Available in various configurations
- Cast iron pumping sections for durability
- Aluminum flanges and covers for optimum power to weight ratio.
- Journal bearings for long life and good over-hung load capability
- Buna-N Seals are standards for petroleum and glycol based fluids "Viton" seals are optional.
- Pressure balanced plates for greater efficiency.

	<u>Series Description</u>	<u>Page</u>
	<b>P16</b> - Standard Pump .....	<b>181 - 184</b>
	<b>TP16-2</b> - Tandem, 2 Place .....	<b>185 - 188</b>
	<b>TP16-3</b> - Tandem, 3 Place .....	<b>189 - 192</b>
	<b>PVP16</b> - Priority Valve Gear .....	<b>193 - 197</b>
	<b>CP16</b> - Clutch Option .....	<b>199 - 202</b>
	<b>DP16</b> - Dump Pump Option .....	<b>203 - 206</b>

## Series 20

### FEATURES:

- Available in various configurations
- Construction:  
Aluminum - For excellent power to weight ratio or Cast iron - for extra durability.
- Journal bearings for long life and good over-hung load capability
- Buna-N Seals are standards for petroleum and glycol based fluids "Viton" seals are optional.
- Pressure balanced plates for greater efficiency.

	<u>Series Description</u>	<u>Page</u>
	<b>20</b> - Standard Pump .....	<b>207 - 209</b>
	<b>R20</b> - Reversible Pump.....	<b>211 - 214</b>
	<b>M20</b> - Motor .....	<b>215 - 217</b>
	<b>TP20-2</b> - Tandem, 2 Place .....	<b>219 - 221</b>
	<b>TP20-3</b> - Tandem, 3 Place .....	<b>223 - 226</b>
	<b>NST20</b> - Flow Sensitive.....	<b>227 - 230</b>
	<b>NSD20</b> - Flow Sensitive.....	<b>231 - 234</b>
	<b>NDS20</b> - Pressure Summation .....	<b>235 - 238</b>
	<b>SPM20</b> - Two-Speed .....	<b>239 - 241</b>

## Pump and Motor Displacement Chart

UNIT SIZE	DISPLACEMENT			DISPLACEMENT IN GPM AT SPEEDS INDICATED								
	U.S. GPR	CIR	LPR	1200	1800	1900	2000	2100	2200	2300	2400	2500
P1-10	.000886	.2047	.00335	1.06	1.59	1.68	1.77	1.86	1.95	2.04	2.13	2.21
P1-15	.001330	.3072	.00503	1.60	2.39	2.53	2.66	2.79	2.93	3.06	3.19	3.32
P1-20	.001773	.4096	.00671	2.13	3.19	3.37	3.55	3.72	3.90	4.08	4.25	4.43
P1-25	.002216	.5119	.00838	2.70	3.99	4.21	4.43	4.65	4.87	5.10	5.32	5.54
(2)P1-30	.002955	.6826	.01119	3.55	5.32	5.61	5.91	6.21	6.50	6.80	7.09	7.39
				<b>1000</b>	<b>1200</b>	<b>1800</b>	<b>2000</b>	<b>2200</b>	<b>2400</b>	<b>2600</b>	<b>2800</b>	<b>3000</b>
P12-17	.0014	.333	.0055	1.40	1.68	2.52	2.80	3.08	3.36	3.64	3.92	4.20
P12-22	.0019	.433	.0073	1.90	2.28	3.42	3.80	4.18	4.56	4.94	5.32	5.70
P12-28	.0024	.554	.0091	2.40	2.88	4.32	4.80	5.28	5.76	6.24	6.72	7.20
P12-34	.0030	.683	.0112	3.00	3.60	5.40	6.00	6.60	7.20	7.80	8.40	9.00
P12-40	.0034	.794	.0130	3.40	4.08	6.12	6.80	7.48	8.16	8.84	9.52	10.20
P12-45	.0039	.905	.0148	3.90	4.68	7.02	7.80	8.58	9.36	10.14	10.92	11.70
P14-42	.0035	.808	.0132	3.50	4.20	6.30	7.00	7.70	8.40	9.10	9.80	10.50
P14-59	.0049	1.132	.0185	4.90	5.88	8.82	9.80	10.78	11.76	12.74	13.72	14.70
P14-74	.0062	1.432	.0235	6.20	7.44	11.16	12.40	13.64	14.88	16.12	17.36	18.60
P14-91	.0076	1.756	.0288	7.60	9.12	13.68	15.20	16.72	18.24	19.76	21.28	22.80
P14-108	.0090	2.079	.0341	9.00	10.80	16.20	18.00	19.80	21.60	23.40	25.20	27.00
				<b>1200</b>	<b>1800</b>	<b>1900</b>	<b>2000</b>	<b>2100</b>	<b>2200</b>	<b>2300</b>	<b>2400</b>	<b>2500</b>
P2-45	.00397	.918	.01503	4.76	7.15	7.55	7.95	8.34	8.74	9.14	9.54	9.94
P2-65	.00561	1.296	.02123	6.73	10.10	10.67	11.22	11.79	12.35	12.91	13.47	14.02
P2-85	.00728	1.681	.02755	8.73	13.10	13.82	14.57	15.29	16.00	16.75	17.48	18.20
P2-95	.00817	1.887	.03092	9.80	14.70	15.50	16.34	17.13	17.95	18.75	19.60	20.40
(2)P2-105	.00872	2.014	.03301	10.46	15.70	16.57	17.44	18.31	19.18	20.06	20.93	21.80
P2-115	.0100	2.31	.03785	12.00	18.00	19.00	20.00	21.00	22.00	23.00	24.00	25.00
P2-150	.01328	3.090	.05026	15.70	23.60	24.90	26.20	27.60	28.80	30.20	31.50	32.80
P2-200	.0169	3.904	.06396	20.30	30.40	32.10	33.80	35.50	37.20	38.90	40.50	42.20
				<b>1000</b>	<b>1200</b>	<b>1800</b>	<b>2000</b>	<b>2200</b>	<b>2400</b>	<b>2600</b>	<b>2800</b>	<b>3000</b>
P16-45	.0038	.878	.0144	3.80	4.56	6.84	7.60	8.36	9.12	9.88	10.64	11.40
P16-65	.0055	1.270	.0208	5.55	6.66	9.90	11.00	12.10	13.20	14.30	15.40	16.50
P16-85	.0072	1.663	.0273	7.20	8.64	12.96	14.40	15.84	17.28	18.72	20.16	21.60
P16-100	.0085	1.964	.0321	8.50	10.20	15.30	17.00	18.70	20.40	22.10	23.80	25.50
P16-115	.0097	2.241	.0367	9.70	11.64	17.46	19.40	21.34	23.28	25.22	27.16	29.10
P16-150	.0127	2.934	.0481	12.70	15.24	22.86	25.40	27.94	30.48	33.02	35.56	(3)
P16-180	.0152	3.511	.0575	15.20	18.24	27.36	30.40	33.44	36.48	(4)	(4)	(4)
P16-200	.0169	3.902	.0639	16.69	20.28	30.42	33.80	37.18	40.56	(4)	(4)	(4)
P16-250	.0211	4.874	.0798	21.10	25.32	37.98	42.20	46.42	50.64	(4)	(4)	(4)
				<b>1200</b>	<b>1800</b>	<b>1900</b>	<b>2000</b>	<b>2100</b>	<b>2200</b>	<b>2300</b>	<b>2400</b>	<b>2500</b>
P6-060	.0052	1.201	.01968	6.24	9.36	9.88	10.40	10.92	11.44	11.96	12.48	13.00
P6-080	.0070	1.617	.02650	8.40	12.60	13.30	14.00	14.70	15.40	16.10	16.80	17.50
P6-100	.0087	2.010	.03293	10.49	15.65	16.53	17.40	18.27	19.14	20.01	20.88	21.75
P6-120	.0105	2.426	.03974	12.60	18.90	19.95	21.00	22.05	23.10	24.15	25.20	26.25
P6-150	.0131	3.026	.04958	15.72	23.58	24.89	26.20	27.51	28.82	30.13	31.44	32.75
				<b>1000</b>	<b>1200</b>	<b>1400</b>	<b>1600</b>	<b>1800</b>	<b>2000</b>	<b>2200</b>	<b>2400</b>	<b>2500</b>
PM23-13	.0109	2.518	.0413	10.90	13.08	15.26	17.44	19.62	21.80	23.98	26.16	27.25
PM23-16	.0137	3.165	.0519	13.70	16.44	19.18	21.92	24.66	27.40	30.14	32.88	34.25
PM23-19	.0164	3.788	.0621	16.40	19.68	22.96	26.24	29.52	32.80	36.08	39.36	41.00
PM23-22	.0192	4.435	.0727	19.20	23.04	26.88	30.72	34.56	38.40	42.24	46.08	48.00
PM23-25	.0219	5.059	.0829	21.90	26.28	30.66	35.04	39.42	43.80	48.18	52.56	54.75
PM23-28	.0247	5.706	.0935	24.70	29.64	34.58	39.52	44.46	49.40	54.34	59.28	61.75
PM23-31	.0274	6.329	.1037	27.40	32.88	38.36	43.84	49.32	54.80	60.28	65.76	68.50

## Pump and Motor Displacement Chart

UNIT SIZE	DISPLACEMENT			DISPLACEMENT IN GPM AT SPEEDS INDICATED								
	U.S. GPR	CIR	LPR	600	800	900	1000	1200	1400	1600	1800	2000
DPH 25	.0210	5.070	.082	12.60	16.80	18.90	21.00	25.20	29.40	33.60	37.80	42.00
DPH 36	.0300	6.930	.113	18.00	24.00	27.00	30.00	36.00	42.00	48.00	54.00	60.00
				<b>1200</b>	<b>1800</b>	<b>1900</b>	<b>2000</b>	<b>2100</b>	<b>2200</b>	<b>2300</b>	<b>2400</b>	<b>2500</b>
20060	.0052	1.201	.01968	6.24	9.36	9.88	10.40	10.92	11.44	11.96	12.48	13.00
20080	.0070	1.617	.02650	8.40	12.60	13.30	14.00	14.70	15.40	16.10	16.80	17.50
20100	.0087	2.02	.03293	10.44	15.66	16.53	17.40	18.27	19.14	20.01	20.88	21.75
(2)20120	.0105	2.426	.03974	12.60	18.90	19.95	21.00	22.05	23.10	24.15	25.20	26.25
(2)20130	.0113	2.610	.04277	13.56	20.34	21.47	22.60	23.73	24.86	25.99	27.12	28.25
(2)20140	.0122	2.818	.04618	14.64	21.96	23.18	24.40	25.62	26.84	28.06	29.28	30.50
20150	.0131	3.02	.04958	15.72	23.58	24.89	26.20	27.51	28.82	30.13	31.44	32.75
(2)20180	.0157	3.627	.05942	18.84	28.26	29.83	31.40	32.97	34.54	36.11	37.68	39.25
20200	.0175	4.04	.06624	21.00	31.50	33.25	35.00	36.75	38.50	40.25	42.00	43.75
20250	.0219	5.06	.08289	26.28	39.42	41.61	43.80	45.99	48.18	50.37	52.56	54.75
(2)20280	.0245	5.660	.09273	29.40	44.10	46.55	49.00	51.45	53.90	56.35	58.80	61.25
20300	.0262	6.05	.09917	31.44	47.16	49.78	52.40	55.02	57.64	60.26	62.88	65.50
20350	.0306	7.07	.11582	36.72	55.08	58.14	61.20	64.26	67.32	70.38	73.44	76.50
20400	.0350	8.08	.13248	42.00	63.00	66.50	70.00	73.50	77.00	80.50	84.00	87.50
20450	.0394	9.10	.14913	47.28	70.92	74.86	78.80	82.74	86.68	90.62	94.56	98.50
(2)20500	.0414	9.563	.15670	49.68	74.52	78.66	82.80	86.94	91.08	95.22	98.36	103.50
(2)25300	.0262	6.05	.09917	31.44	47.16	49.78	52.40	55.02	57.64	60.26	62.88	65.50
25350	.0306	7.07	.11582	36.72	55.08	58.14	61.20	64.26	67.32	70.38	73.44	76.50
25400	.0350	8.085	.13248	42.00	63.00	66.50	70.00	73.50	77.00	80.50	84.00	87.50
25450	.0394	9.100	.14913	47.28	70.92	74.86	78.80	82.74	86.68	90.62	94.56	98.50
25500	.0435	10.05	.16460	52.20	78.30	82.65	87.00	91.35	95.70	100.05	104.40	108.75
25550	.0479	11.06	.1813	57.48	86.22	91.10	95.80	100.59	105.38	110.17	114.96	119.75
25660	.0581	13.42	.2199	69.72	104.58	110.39	116.20	122.01	127.82	133.63	139.44	145.25
25770	.0671	15.50	.2540	80.52	120.78	127.49	143.20	140.91	147.62	154.33	161.04	167.75
(2)25850	.0740	17.09	.2801	88.80	133.20	140.60	148.00	155.40	162.80	170.20	177.60	185.00
25950	.0832	19.22	.3149	99.84	149.76	158.08	166.40	174.72	(1)	(1)	(1)	(1)
HP7-250	.0219	5.06	.08289	26.28	39.42	41.61	43.80	45.99	48.18	50.37	52.65	54.75
HP7-300	.0262	6.05	.09917	31.44	47.16	49.78	52.40	55.02	57.64	60.26	62.88	65.50
HP7-350	.0306	7.07	.11582	36.72	55.08	58.14	61.20	64.26	67.32	70.38	73.44	76.50
HP7-400	.0339	7.83	.1283	40.68	61.02	64.41	67.80	71.19	74.58	77.97	81.36	84.75
HP7-450	.0379	8.75	.1435	45.48	68.22	72.01	75.80	79.59	83.38	87.17	90.96	94.75
HP7-500	.0422	9.75	.1597	50.64	75.96	80.18	84.40	88.62	92.84	97.06	101.28	105.50
HP7-550	.0465	10.74	.1760	55.80	83.70	88.35	93.00	97.65	102.30	106.95	111.60	116.25
HP8-400	.0339	7.83	.1283	40.68	61.02	64.41	67.80	71.19	74.58	77.97	81.36	84.75
HP8-450	.0379	8.75	.1435	45.48	68.22	72.01	75.80	79.59	83.38	87.17	90.96	94.75
HP8-500	.0422	9.75	.1597	50.64	75.96	80.18	84.40	88.62	92.84	97.06	101.28	105.60
HP8-550	.0465	10.74	.1760	55.80	83.70	88.35	93.00	97.65	102.30	106.95	111.60	116.25
HP8-600	.0510	11.78	.1930	61.20	91.80	96.90	102.00	107.10	112.20	112.30	122.40	127.60
HP8-660	.0565	13.05	.2139	67.80	101.70	107.35	113.00	118.65	124.30	129.95	135.60	141.25
HP8-770	.0650	15.02	.2460	78.00	117.00	123.50	130.00	136.50	143.00	149.50	156.00	162.50
HP8-850	.0709	16.38	.2648	85.08	127.62	134.71	141.80	148.89	155.98	163.02	170.16	177.25

(1) Models limited to 2100 RPM.

(2) Non-catalog sizes — special order only.

(3) Models limited to 2800 RPM

(4) Models limited to 2500 RPM

**GENERAL PRODUCT  
AND SAFETY INFORMATION****INTENDED USE OF THESE PRODUCTS**

**WARNING:** The Pumps and motors in this catalog are designed for, and intended for use, only on mobile equipment hydraulic systems. Use of these pumps and motors or other applications will void the warranty, as such use may also result in damage to the pump and motor, or to other equipment in the system.

In some cases, use for unapproved applications could result in serious bodily injury from an equipment failure. In order to avoid property damage or bodily injury, do not use these pumps and motors for other applications.

**CONSIDERATIONS FOR MAXIMUM PRODUCT LIFE AND PERFORMANCE**

Things to be considered include, but are not limited to:

- fluid type and cleanliness.
- system flow and pressure requirements (including pressure spikes)
- adequate port and plumbing sizes.
- reservoir size and location.
- operating temperature.
- integrated system valving.
- duty cycle.
- operating speeds.

**HYDRAULIC OIL REQUIREMENTS**

To obtain maximum life of gresen pumps and motors, the hydraulic fluid must meet or exceed the specifications shown on page 142.



**CAUTION:** Failure to use fluids that meet these specifications can shorten the life of the pump and/or motor, and result in failure. A failure due to the use of improper fluids, may in some instances result in damage to other items in the hydraulic circuit. Such failures will not be covered by warranty.

Clean oil is important and we recommend at least a minimal 10 micron return filter, properly sized for the system and maintained on a regular service schedule to a minimum ISO cleanliness level of 17/14.

Gresen pumps and motors work well on most fire resistant fluids, but because some of these fluids require special seals, these applications should be approved in advance by Gresen Pump Engineering.



**WARNING:** Improperly installed or maintained pumps and motors, and their connections, could result in external leakage, which may cause property damage or serious bodily injury. In order to avoid such damage or injury, you should carefully follow all installation and maintenance instructions which accompany the product.



**WARNING:** When using those items that may require tapping into the vehicle air brake system (e.g., pneumatic controls for "air cylinders" on Dry Valve Pumps or "air shifters" on Dump Pumps) a "Pressure Protection Valve" (our part number 16393) or the equivalent) should be used. In the event of a failure in the air cylinder, air shifter, or their control lines, a Pressure Protection Valve will prevent the loss of air from the vehicle brake circuit. Loss of air from the vehicle brake circuit could cause loss of control of the vehicle, which could result in serious injury or death.

**BUILDERS AND REBUILDERS**

**CAUTION:** For those who are authorized to build and rebuild Gresen gear pumps and motors, the tolerances on new parts require that a pump or motor be assembled and "run-in" according to a specific procedure. This should be done on a test stand with proper filtration rather than on the application, as the run-in procedure will generate metallic particles, which if not caught, may cause damage throughout the system.

**If there are any questions or clarifications required, please contact:**

**Hercules Hydraulics Component Division**

**Phone Toll Free in the U.S. at 1-800-333-5617**

## Assembly Torque Values

### NOTES:

All torque values are based on a lubricated condition. If capscrews and/or nuts are dirty, they must be washed, blown dry, and re-oiled prior to installation. All studs must be washed and blown dry—**DO NOT** re-oil.

The following torque values are to be used in the assembly of pumps and motors:

SERIES	SIZE	TORQUE (FT.-LBS.)
P1	5/16"	20-25
P12	M10	20-25
P14, FP14, TFP14	3/8"	30-35
SSFP14	1/2"	80-90
P2	3/8"	30-35
P16, HP16	1/2"	70-75
FPR16	1/2"	80-90
FP16	5/8"	160-175
TFP16	5/8"	160-175
SSFP16	5/8"	160-175
DP16	1/2"	70-75
DP16 (valve)	3/8"	30-35
FP17	5/16"	18-20
20, M20, FP20	1/2"	80-90
P6, FM6, TM6	1/2"	80-90
25, M25, FP25	5/8"	160-175
FP257, FPW257	5/8"	160-175
HP7, HM7, FP7	3/4"	240-250
SL7	5/8"	160-175
HP8, HM8, FP8, SL8	3/4"	240-250
PM23	5/8"	180-190
DPH	5/8"	180-190
HILLSDALE	3/8"	40-45
HILLSDALE	7/16"	50-55
T101/102	5/8"	195-200
MGG/PGG (body)	5/16"	21-24
MGG/PGG (flange)	#10	46-54 (in.-lb.)

### NOTES:

For "Mixed" Series, ie: TP25450-20200-P14-45A, use torque values corresponding to each section: 25 Series for the 25450 (160-175), 20 Series for the 20200 (80-90), and P14 Series for the P14-45 (30-35). Verify stud/capscrew sizes.

Torque value should be divided into two or three equal values, and applied in stages. e.g. P16 should be first torqued to 35 ft. lbs. then torqued to the final value of 70-75 ft. lbs.

While torquing the pump please follow pattern as shown below:

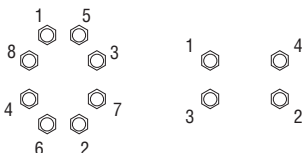

## Overhung Load Data

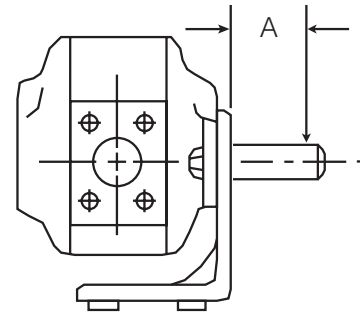

PUMP SIZE	Dim. "A"	Allowable Load "L"	Allowable Operating Pressure
P12-17	1.00"	100 Lbs..	2000 PSI
-22	"	"	"
-28	"	"	"
-34	"	"	"
-40	"	"	"
-45	"	"	"
P14-42	1.00"	200 Lbs..	2000 PSI
-59	"	"	"
-74	"	"	"
-91	"	"	"
-108	"	"	"
P16-45	1.00"	390 Lbs..	2200 PSI
-65	"	"	2200 PSI
-85	"	"	2100 PSI
-100	"	"	2100 PSI
-115	"	"	2000 PSI
-150	"	"	1800 PSI
-180	"	"	1700 PSI
-200	"	"	1600 PSI
20150	1.50"	1050 Lbs..	2000 PSI
20200	"	"	"
20250	"	"	"
20300	"	"	"
20350	"	"	"
20400	"	"	"
20450	"	"	"
25500	1.50"	1050 Lbs..	1800 PSI
25550	"	"	1600 PSI
25600	"	"	1350 PSI
25770	"	"	1150 PSI
25950	"	"	900 PSI
HP7	1.50"	1300 Lbs..	3000 PSI
HP8	1.50"	1300 Lbs..	2800 PSI

Allowable Load "L" must not be exceeded.

When Belt Drive is used, "L" must include both belt pre-tension and torque load.

**ntertech Cylinders, Pumps & Motors / Custom Hoists / LHA  
Accessories / Cylinders / Prince Cylinders & Pumps / Chief  
Cylinders / Perfection Pumps / White Motors / Gresen®  
Cylinders, Pumps, Motors & Valves / Commercial Intertech  
Cylinders, Pumps & Motors / Custom Hoists / LHA Accessories  
Cylinders / Prince Cylinders & Pumps / Chief Cylinders /  
Perfection Pumps / White Motors / Gresen® Cylinders, Pumps  
Motors & Valves / Commercial Intertech Cylinders, Pumps &  
Motors / Custom Hoists / LHA Accessories / Cylinders / Prince  
Cylinders & Pumps / Chief Cylinders / Perfection Pumps / White  
Motors / Gresen® Cylinders, Pumps, Motors & Valves /  
Commercial Intertech Cylinders, Pumps & Motors / Custom  
Hoists / LHA Accessories / Cylinders / Prince Cylinders &  
Pumps / Chief Cylinders / Perfection Pumps / White Motors /  
Gresen® Cylinders, Pumps, Motors & Valves / Commercial  
ntertech Cylinders, Pumps & Motors / Custom Hoists / LHA  
Accessories / Cylinders / Prince Cylinders & Pumps / Chief  
Cylinders / Perfection Pumps / White Motors / Gresen®  
Cylinders, Pumps, Motors & Valves / Commercial Intertech  
Cylinders, Pumps & Motors / Custom Hoists / LHA Accessories  
Cylinders / Prince Cylinders & Pumps / Chief Cylinders /  
Perfection Pumps / White Motors / Gresen® Cylinders, Pumps,  
Motors & Valves / Commercial Intertech Cylinders, Pumps &  
Motors / Custom Hoists / LHA Accessories / Cylinders / Prince  
Cylinders & Pumps / Chief Cylinders / Perfection Pumps / White  
Motors / Gresen® Cylinders, Pumps, Motors & Valves /  
Commercial Intertech Cylinders, Pumps & Motors / Custom  
Hoists / LHA Accessories / Cylinders / Prince Cylinders &  
Pumps / Chief Cylinders / Perfection Pumps / White Motors /  
Gresen® Cylinders, Pumps, Motors & Valves / Commercial  
ntertech Cylinders, Pumps & Motors / Custom Hoists / LHA  
Accessories / Cylinders / Prince Cylinders & Pumps / Chief  
Cylinders / Perfection Pumps / White Motors / Gresen®  
Cylinders, Pumps, Motors & Valves / Commercial Intertech  
Cylinders, Pumps & Motors / Custom Hoists / LHA Accessories  
Cylinders / Prince Cylinders & Pumps / Chief Cylinders /  
Perfection Pumps / White Motors / Gresen® Cylinders, Pumps**



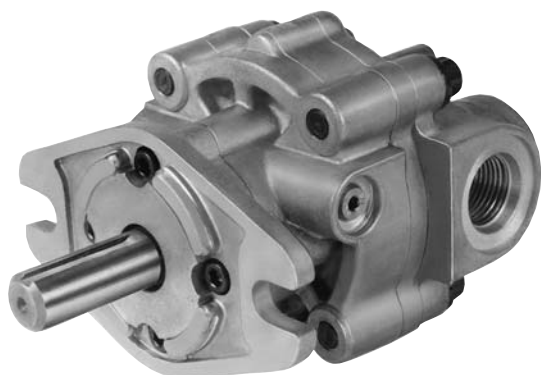

Series MGG2

Description . . . . . Hydraulic Motors  
 Flow Range . . . . . To 15 GPM  
 Displacements . . . . . To .700 C.I.R.  
 Maximum Pressure to . . . . . 2000 PSI  
 Maximum Speed to . . . . . 5000 RPM  
 Rotation . . . . . Bi-Directional  
 Bearings . . . . . Roller  
 Construction . . . . . All Aluminum

## Performance Data

MODEL NO.	DISPLACEMENT/REVOLUTION (Theoretical)					MAXIMUM PRESSURE		MAXIMUM SPEED
	US Gallons	Cubic Inches	Liters	Cubic Centimeters	Imperial Gallons	PSI	BAR	RPM
MGG20010	.0010	.218	.0039	3.572	.001	2000	138	5000
MGG20016	.0016	.372	.0062	6.096	.001	2000	138	5000
MGG20020	.0020	.450	.0078	7.374	.002	2000	138	5000
MGG20025	.0025	.580	.0097	9.505	.002	2000	138	5000
MGG20030	.0030	.700	.0116	11.471	.003	1500	104	5000

## How To Order

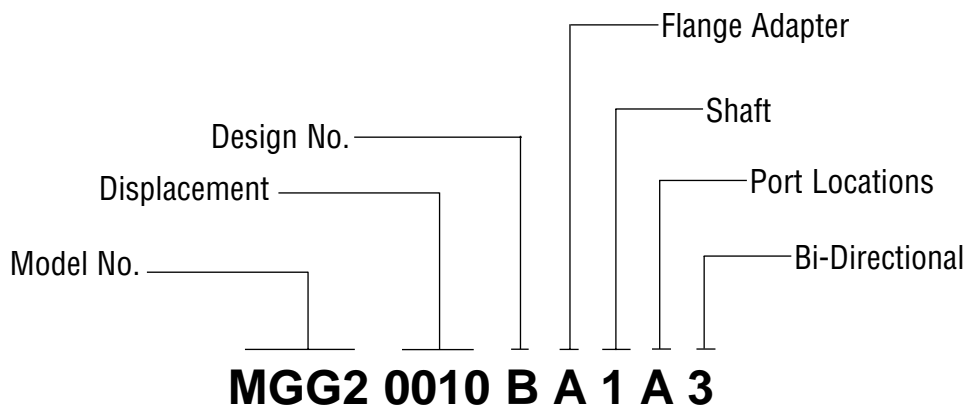

## Shafts Available

<p><b>1</b> 9/16 Dia. Keyed Shaft</p> <p>Involute Spline Data Flat Root Side Fit-Class 2 Fit 16/32 Pitch</p>	<p><b>2</b> 9/16 Dia. Tooth Spline Shaft</p> <p>Involute Spline Data Flat Root Side Fit-Class 2 Fit 16/32 Pitch</p>	<p><b>6</b> 5/8 Dia. 9 Tooth Spline Shaft Available in Models MGG20020, 25 &amp; 30 Only</p> <p>Involute Spline Data (SAE-4986) Flat Root Side Fit-Class 1 Fit 16/32 Pitch</p>
<p><b>7</b> 7/16 Dia. Keyed Shaft</p>	<p><b>9</b> 1/2 Dia. Keyed Shaft (Threaded)</p>	

## Mounting Flanges Available

<p><b>A</b> SAE 'AA' 2-Bolt Adapter</p>	<p><b>B</b> 4-Bolt Adapter</p>	<p><b>C</b> SAE 'A' 2-Bolt Adapter</p>
---	--------------------------------	--

## Cover Plates Available

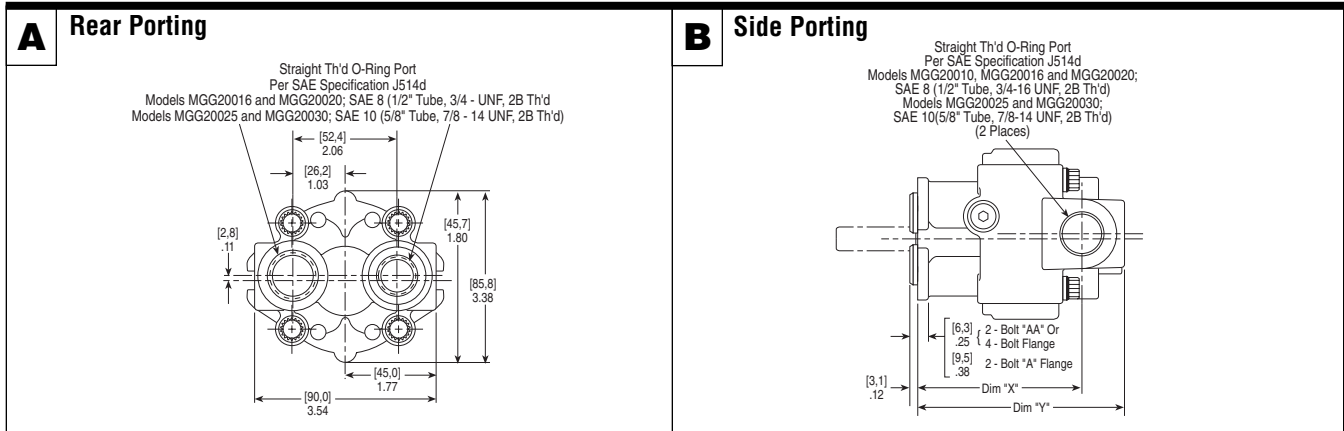

## Dimensional Data

### Mounting Dimensions With Non-Pressure Compensated Adjustable Flow By-Pass

MODEL NO.	DIMENSIONS		
	'X'	'Y'	'Z'
MGG20010	2.86	3.62	4.16
MGG20016	3.02	3.78	4.32
MGG20020	3.10	3.87	4.41
MGG20025	3.25	4.00	4.54
MGG20030	3.38	4.14	4.68

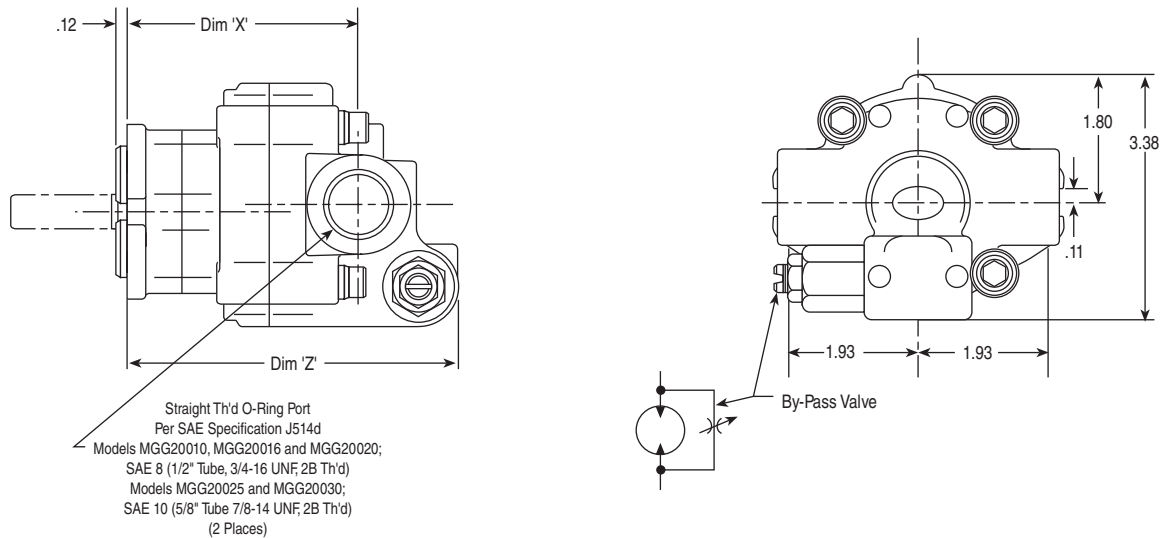

**Torque & Speed Selection Charts**

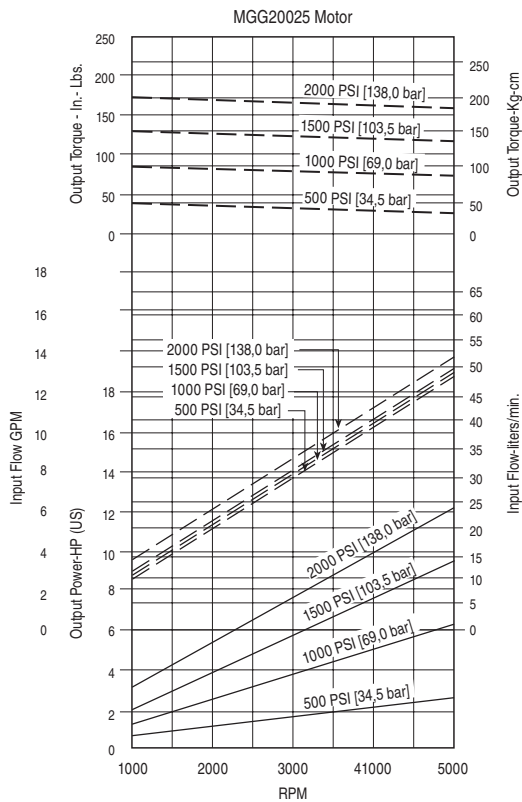
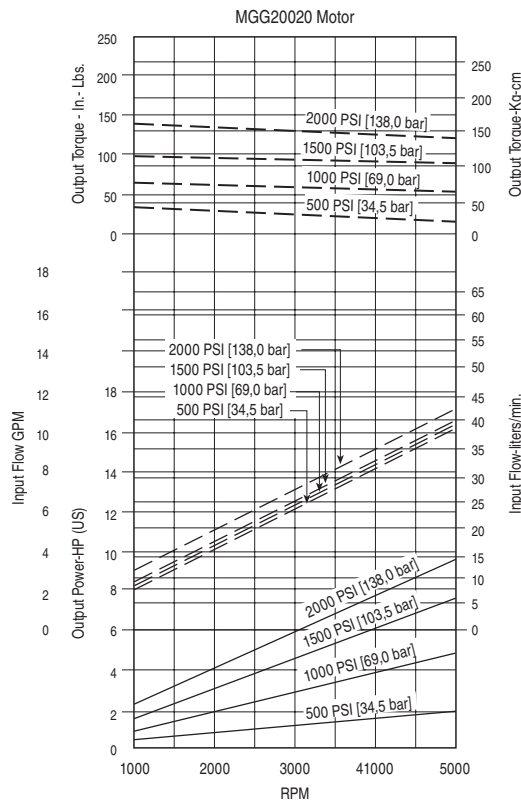
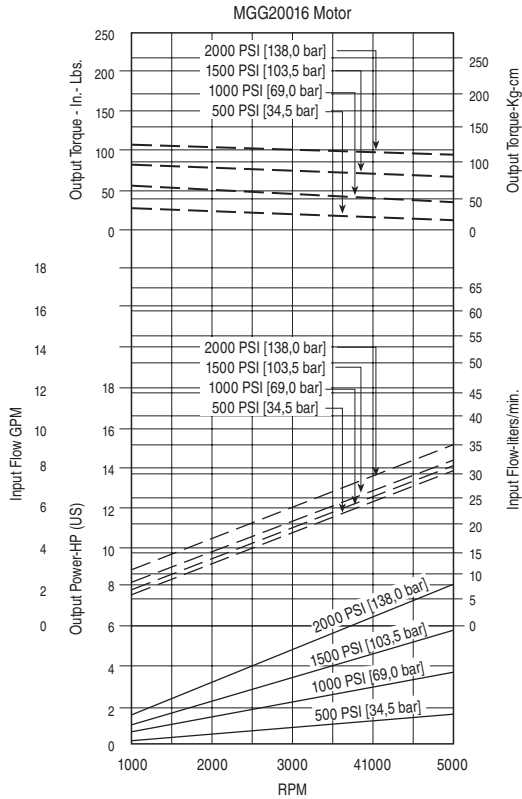
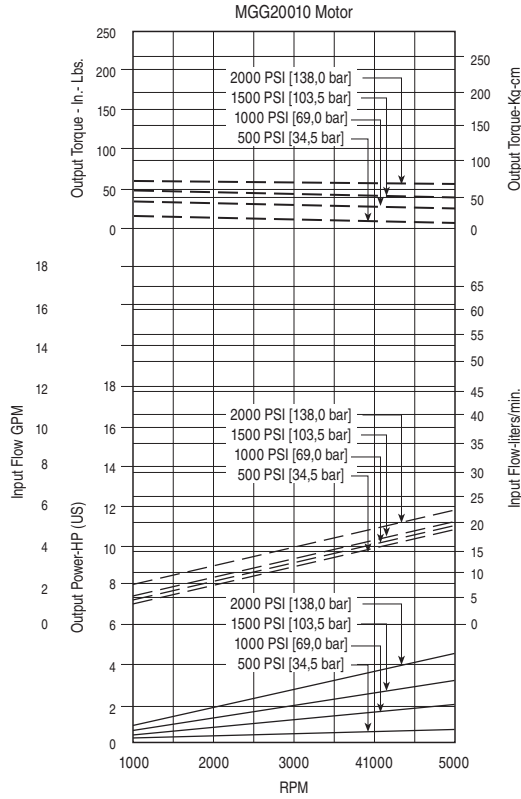

## Torque & Speed Selection Charts

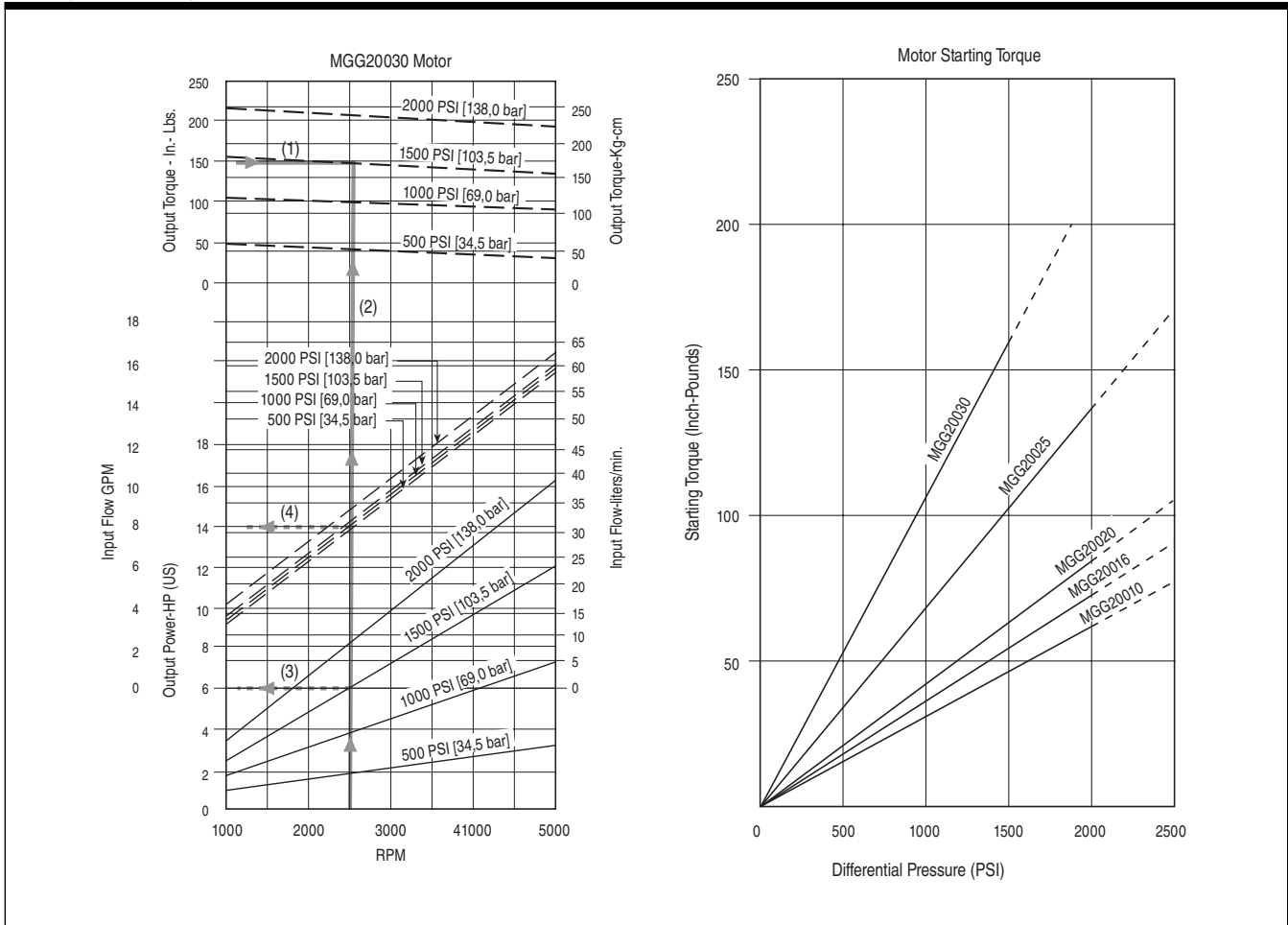

### Motor Selection

MGG2 Hydraulic Motors are available in five basic models—each with its own input/output characteristics.

To properly select a motor, two things must first be determined—the output torque (inch-pound) that the motor is to produce, and the speed requirement (RPM).

Example: It is required that a motor will deliver an output torque of 150 inch-pounds at a speed of 2500 RPM.

To select the motor:

1. Draw a horizontal line (1) at 150 inch-pounds output torque. The MGG20025 and MGG20030 will both develop the required torque.
2. Draw a vertical line (2) up from 2500 RPM. The point of intersection of the 2 lines indicates the working pressure required at the motor to develop 150 inch-pounds at 2500 RPM.
3. The output horsepower is determined by drawing a horizontal line (3) from the intersection of 2500 RPM and the working pressure required at the bottom of the charts.
4. The input flow to the motor is determined by drawing a horizontal line (4) from the intersection of 2500 RPM and working pressure required in the middle of the chart.

In this example, either the MGG20025 or the MGG20030 can be used:

The MGG20025 will develop 150 inch-pounds of output torque at 2500 RPM with a pump output (motor input) of 7 GPM at 1800 PSI. The output horsepower is 6.

The MGG20030 will develop 150 inch-pounds of output torque at 2500 RPM with a pump output (motor input) of 8 GPM at 1500 PSI. The output horsepower is 6.





Series PGG2

Description . . . . . Hydraulic Pumps  
 Flow Range . . . . . To 10 GPM  
 Displacements . . . . . To .700 C.I.R.  
 Maximum Pressure to . . . . . 2000 PSI  
 Maximum Speed to . . . . . 3500 RPM  
 Rotation . . . . . Bi-Directional  
 Bearings . . . . . Roller  
 Construction . . . . . All Aluminum

## Performance Data

MODEL NO.	DISPLACEMENT/REVOLUTION (Theoretical)					MAXIMUM PRESSURE		MAXIMUM SPEED
	<i>US Gallons</i>	<i>Cubic Inches</i>	<i>Liters</i>	<i>Cubic Centimeters</i>	<i>Imperial Gallons</i>	<i>PSI</i>	<i>BAR</i>	<i>RPM</i>
	PGG20010	.0010	.218	.0039	3.572	.001	2000	138
PGG20016	.0016	.372	.0062	6.096	.001	2000	138	3500
PGG20020	.0020	.450	.0078	7.374	.002	2000	138	3500
PGG20025	.0025	.580	.0097	9.505	.002	2000	138	3500
PGG20030	.0030	.700	.0116	11.471	.003	1500	104	3000

## How To Order

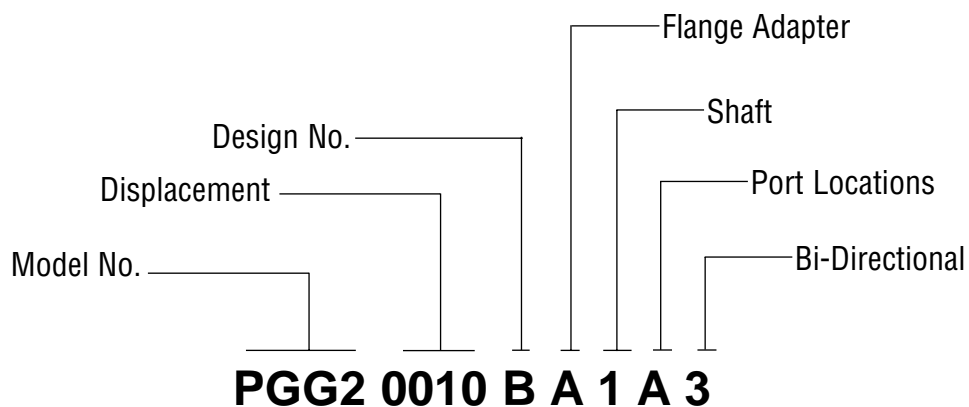

## Shafts Available

<p><b>1</b> 9/16 Dia. Keyed Shaft</p>	<p><b>2</b> 9/16 Dia. Tooth Spline Shaft</p> <p><i>Involute Spline Data Flat Root Side Fit—Class 2 Fit 16/32 Pitch</i></p>	<p><b>6</b> 5/8 Dia. 9 Tooth Spline Shaft</p> <p><i>Involute Spline Data (SAE-4986) Flat Root Side Fit—Class 2 Fit 16/32 Pitch</i></p>
<p><b>7</b> 7/16 Dia. Keyed Shaft</p>	<p><b>9</b> 1/2 Dia. Keyed Shaft (Threaded)</p>	

## Mounting Flanges Available

<p><b>A</b> SAE 'AA' 2-Bolt Adapter</p>	<p><b>B</b> 4-Bolt Adapter</p>	<p><b>C</b> SAE 'A' 2-Bolt Adapter</p>
---	--------------------------------	--

For Gresen® Repair Parts See Pages 493 - 505



## Cover Plates Available

**A Rear Porting**

Straight Th'd O-Ring Port  
Per SAE Specification J514d  
Models MGG20016 and MGG20020; SAE 8 (1/2" Tube, 3/4 - UNF, 2B Th'd)  
Models MGG20025 and MGG20030; SAE 10 (5/8" Tube, 7/8 - 14 UNF, 2B Th'd)

**B Side Porting**

Straight Th'd O-Ring Port  
Per SAE Specification J514d  
Models MGG20010, MGG20016 and MGG20020;  
SAE 8 (1/2" Tube, 3/4-16 UNF, 2B Th'd)  
Models MGG20025 and MGG20030;  
SAE 10(5/8" Tube, 7/8-14 UNF, 2B Th'd)  
(2 Places)

[6,3] .25 { 2 - Bolt "AA" Or  
4 - Bolt Flange  
[9,5] .38 { 2 - Bolt "A" Flange

[3,1] .12

Dim "X"

Dim "Y"

## Dimensional Data

### Mounting Dimensions With Non-Pressure Compensated Adjustable Flow By-Pass

MODEL NO.	DIMENSIONS		
	'X'	'Y'	'Z'
PGG20010	2.86	3.62	4.16
PGG20016	3.02	3.78	4.32
PGG20020	3.10	3.87	4.41
PGG20025	3.25	4.00	4.54
PGG20030	3.38	4.14	4.68

Straight Th'd O-Ring Port  
Per SAE Specification J514d  
Models PGG20010, PGG20016 and PGG20020;  
SAE 8 (1/2" Tube, 3/4-16 UNF, 2B Th'd)  
Models PGG20025 and PGG20030;  
SAE 10 (5/8" Tube 7/8-14 UNF, 2B Th'd)  
(2 Places)

By-Pass Valve

Flow, Pressure, Horsepower & RPM Selection Chart

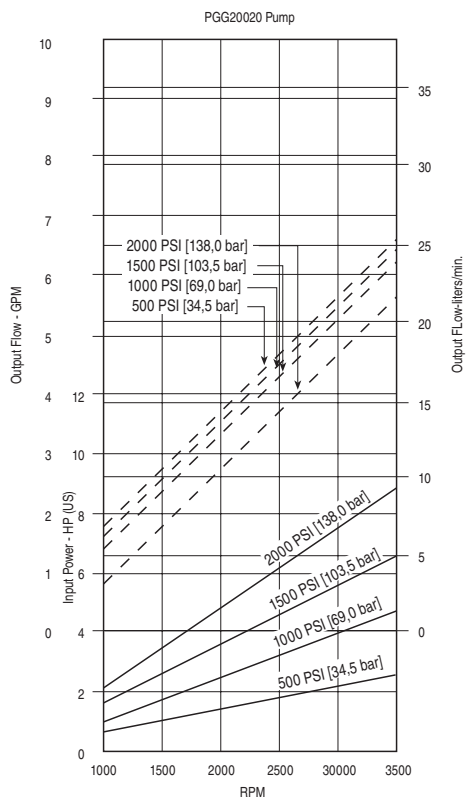
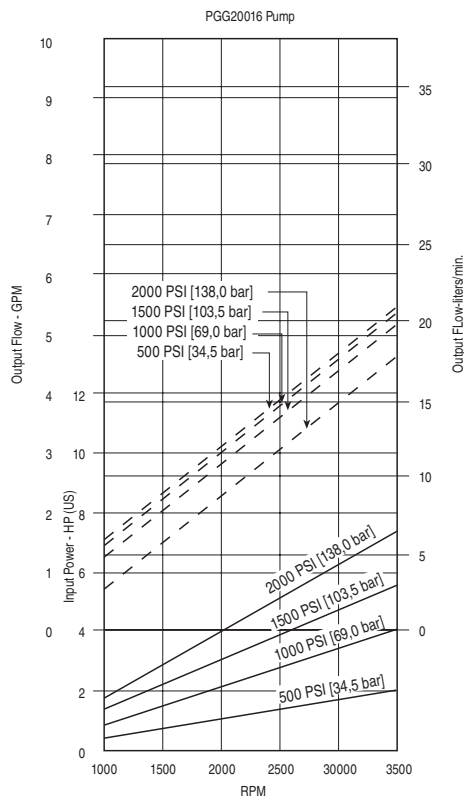
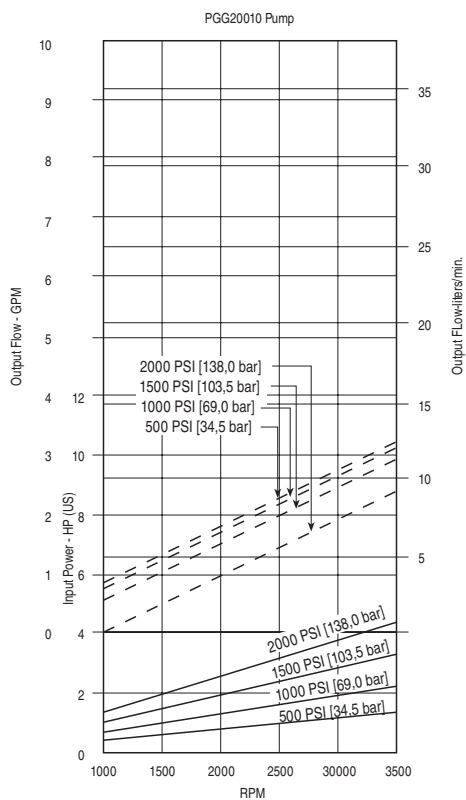

## Flow, Pressure, Horsepower & RPM Selection Chart

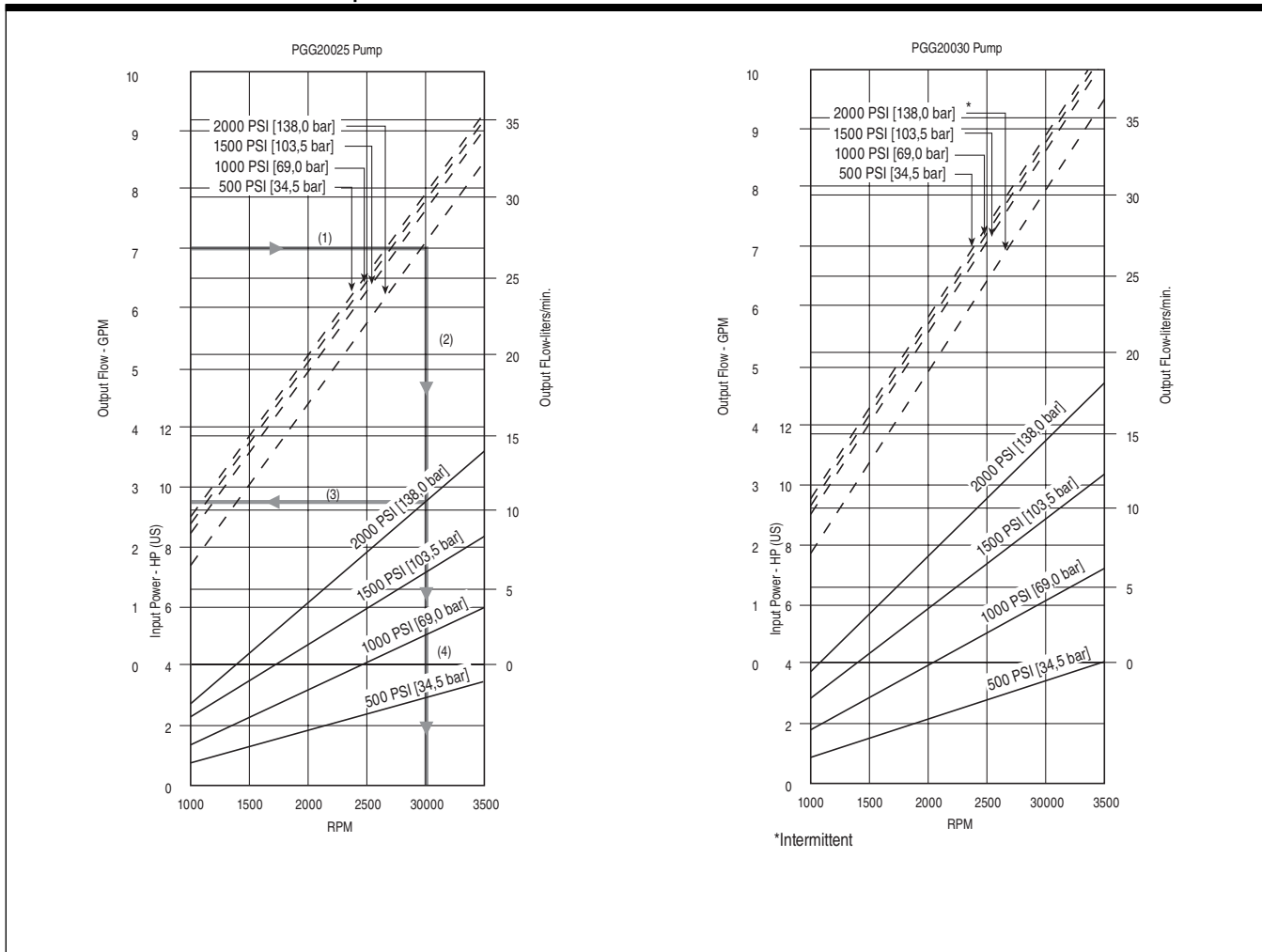

### Pump Selection

Hydraulic pumps are available in five basic models—each with its own input/output characteristics.

To properly select a pump, four things must first be determined:

1. The desired output flow rate
2. The maximum continuous pressure in the hydraulic system
3. The input horsepower required to drive the pump
4. The RPM at which the pump is to operate

Example: It is required that a pump deliver 7 GPM at 2000 PSI, maximum continuous pressure.

1. From the PGG2 Hydraulic Pump Performance Characteristics Charts, it is shown that only the model PGG20025 delivers 7 GPM at a continuous pressure of 2000 PSI. NOTE: PGG20030 is limited to 1500 PSI continuous.
2. Draw line (1) from 7 GPM output flow to where it intersects the line representing 2000 PSI.
3. At the point of intersection, extend line (2) vertically down where it intersects 2000 PSI.
4. By drawing line (3) horizontally across from point of intersection, it is shown that input power requirement is approximately 9.75 HP.
5. By continuing line (4) vertically down, it is shown that input RPM must be 3000.

ntertech Cylinders, Pumps & Motors / Custom Hoists / LHA  
Accessories / Cylinders / Prince Cylinders & Pumps / Chief  
Cylinders / Perfection Pumps / White Motors / Gresen<sup>®</sup>  
Cylinders, Pumps, Motors & Valves / Commercial Intertech  
Cylinders, Pumps & Motors / Custom Hoists / LHA Accessories  
Cylinders / Prince Cylinders & Pumps / Chief Cylinders /  
Perfection Pumps / White Motors / Gresen<sup>®</sup> Cylinders, Pumps,  
Motors & Valves / Commercial Intertech Cylinders, Pumps &  
Motors / Custom Hoists / LHA Accessories / Cylinders / Prince  
Cylinders & Pumps / Chief Cylinders / Perfection Pumps / White  
Motors / Gresen<sup>®</sup> Cylinders, Pumps, Motors & Valves /  
Commercial Intertech Cylinders, Pumps & Motors / Custom  
Hoists / LHA Accessories / Cylinders / Prince Cylinders &  
Pumps / Chief Cylinders / Perfection Pumps / White Motors /  
Gresen<sup>®</sup> Cylinders, Pumps, Motors & Valves / Commercial  
Intertech Cylinders, Pumps & Motors / Custom Hoists / LHA  
Accessories / Cylinders / Prince Cylinders & Pumps / Chief  
Cylinders / Perfection Pumps / White Motors / Gresen<sup>®</sup>  
Cylinders, Pumps, Motors & Valves / Commercial Intertech  
Cylinders, Pumps & Motors / Custom Hoists / LHA Accessories  
Cylinders / Prince Cylinders & Pumps / Chief Cylinders /  
Perfection Pumps / White Motors / Gresen<sup>®</sup> Cylinders, Pumps,  
Motors & Valves / Commercial Intertech Cylinders, Pumps &  
Motors / Custom Hoists / LHA Accessories / Cylinders / Prince  
Cylinders & Pumps / Chief Cylinders / Perfection Pumps / White  
Motors / Gresen<sup>®</sup> Cylinders, Pumps, Motors & Valves /  
Commercial Intertech Cylinders, Pumps & Motors / Custom  
Hoists / LHA Accessories / Cylinders / Prince Cylinders &  
Pumps / Chief Cylinders / Perfection Pumps / White Motors /  
Gresen<sup>®</sup> Cylinders, Pumps, Motors & Valves / Commercial  
Intertech Cylinders, Pumps & Motors / Custom Hoists / LHA  
Accessories / Cylinders / Prince Cylinders & Pumps / Chief  
Cylinders / Perfection Pumps / White Motors / Gresen<sup>®</sup>  
Cylinders, Pumps, Motors & Valves / Commercial Intertech  
Cylinders, Pumps & Motors / Custom Hoists / LHA Accessories  
Cylinders / Prince Cylinders & Pumps / Chief Cylinders /  
Perfection Pumps / White Motors / Gresen<sup>®</sup> Cylinders, Pumps

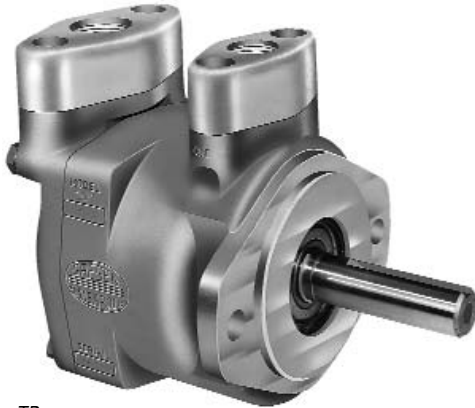

Series TB

Description . . . . . Hydraulic Pumps  
 Flow Range . . . . . 3 To 12 GPM  
 Displacements . . . . . To 2.31 C.I.R.  
 Maximum Pressure to . . . . . 1500 PSI  
 Maximum Speed to . . . . . 2000 RPM  
 Rotation . . . . . Optional  
 Construction . . . . . All Aluminum  
 Shipping Weight . . . . . 11 lbs.

## Performance Data

MODEL NO.	RPM	DELIVERY GPM @				HORSE POWER INPUT @			
		100 PSI	500 PSI	1000 PSI	1500 PSI	100 PSI	500 PSI	1000 PSI	1500 PSI
TB-3	700	2.20	1.90	1.82	1.40	0.24	1.04	1.97	2.97
	900	2.84	2.57	2.40	2.02	0.33	1.34	2.58	3.78
	1200	3.79	3.49	3.30	2.94	0.49	1.83	3.43	4.97
	1500	4.75	4.44	4.14	3.83	0.69	2.33	4.28	6.14
	1800	5.68	5.36	5.00	4.74	0.91	2.85	5.14	7.34
TB-6	500	2.80	2.45	2.25	1.80	0.19	1.14	2.18	3.25
	900	5.15	4.80	4.50	4.05	0.40	2.08	3.94	5.81
	1200	6.95	6.59	6.25	5.80	0.61	2.84	5.27	7.69
	1500	8.7	8.3	7.9	7.45	0.83	3.57	6.64	9.61
	1800	10.48	10.08	9.61	9.15	1.14	4.37	8.02	11.56
TB-9	500	4.08	3.90	3.44	2.92	0.24	1.44	2.89	4.38
	900	7.50	7.23	6.82	6.22	0.54	2.68	5.22	7.86
	1200	10.10	9.80	9.40	8.74	0.82	3.67	6.96	10.47
	1500	12.62	12.25	11.85	11.21	1.16	4.71	8.85	13.08
	1800	15.15	14.75	14.35	13.7	1.63	5.82	10.76	15.84
TB-12	500	5.35	5.05	4.73	4.25	0.30	1.74	3.59	5.42
	900	9.73	9.45	9.05	8.58	0.68	3.21	6.52	9.73
	1200	12.95	12.68	12.25	11.75	1.08	4.41	8.75	12.99
	1500	16.15	15.90	15.50	14.93	1.55	5.76	11.08	16.27
	1800	19.40	19.18	18.70	18.18	2.17	7.19	13.56	19.70

## How To Order

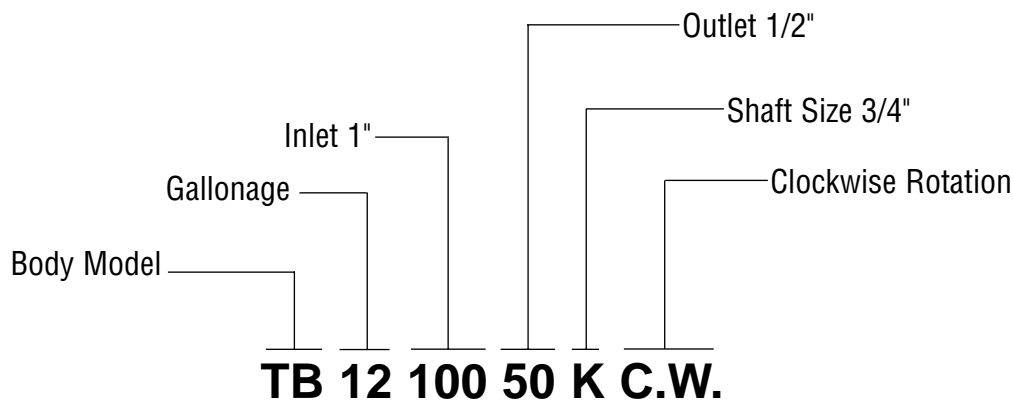

Description . . . . . Hydraulic Pumps  
 Flow Range . . . . . 12 To 24 GPM  
 Displacements . . . . . To 4.62 C.I.R.  
 Maximum Pressure to . . . . . 1500 PSI  
 Maximum Speed to . . . . . 2000 RPM  
 Rotation . . . . . Optional  
 Construction . . . . . All Aluminum  
 Shipping Weight . . . . . 16 1/2 lbs.

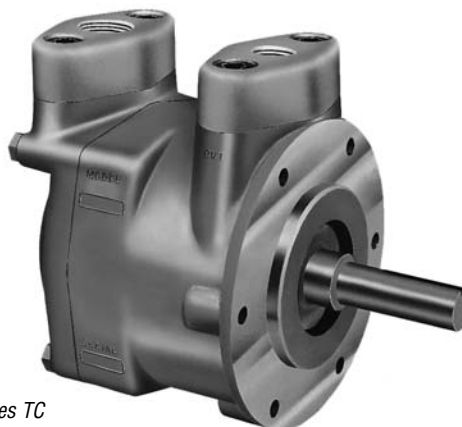

Series TC

**Performance Data**

MODEL NO.	RPM	DELIVERY GPM @				HORSE POWER INPUT @			
		100 PSI	500 PSI	1000 PSI	1500 PSI	100 PSI	500 PSI	1000 PSI	1500 PSI
TC-12	500	5.0	4.1	3.7	2.7	0.33	1.70	3.53	5.30
	900	9.1	8.2	7.7	6.7	0.83	3.31	6.44	9.56
	1200	12.21	11.4	10.7	9.8	1.29	4.59	8.74	12.77
	1500	15.4	14.5	13.7	12.8	1.78	5.95	11.04	16.01
	1800	18.5	17.5	16.6	15.8	2.48	7.42	13.50	19.41
TC-16	500	6.9	6.4	5.9	5.0	0.42	2.32	4.73	7.12
	900	12.7	12.2	11.6	10.7	1.06	4.45	8.75	13.02
	1200	17.0	16.4	15.9	15.0	1.71	6.22	11.87	17.53
	1500	21.3	20.7	20.2	19.3	2.57	8.18	15.22	22.17
	1800	25.7	25.1	24.5	23.6	3.54	10.33	18.78	27.12
TC-20	500	8.2	7.7	7.1	6.2	0.61	2.50	5.25	7.89
	900	14.8	14.4	13.6	12.8	1.40	4.92	9.71	14.49
	1200	19.9	19.4	18.6	17.8	2.15	6.98	13.32	19.60
	1500	26.5	24.3	23.6	22.6	3.14	9.28	17.22	24.98
	1800	30.0	29.2	28.4	27.5	4.28	11.82	21.32	30.69
TC-24	500	9.7	9.1	8.3	7.4	0.76	2.80	5.92	9.06
	900	17.5	16.9	16.1	15.0	1.69	5.52	11.10	16.68
	1200	23.4	22.7	21.9	20.8	2.64	7.86	15.26	22.61
	1500	29.2	28.5	27.8	26.5	3.78	10.59	19.74	28.95
	1800	35.0	34.2	33.4	32.2	4.99	13.62	24.55	35.48

**How To Order**

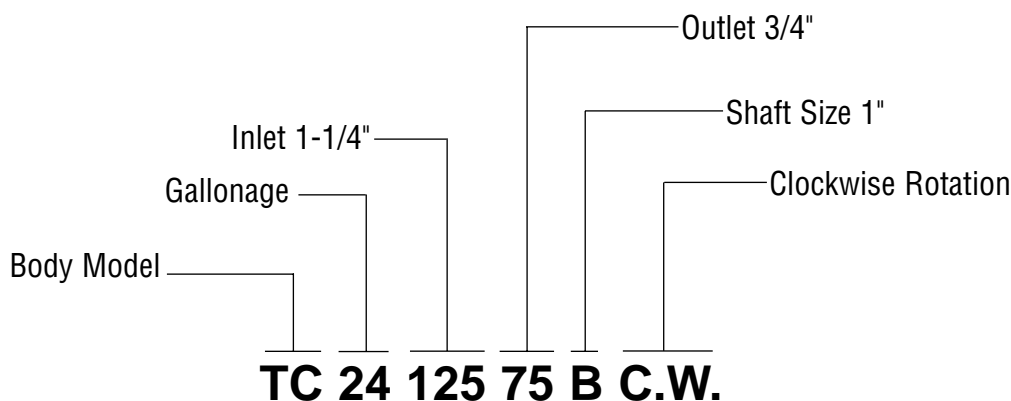

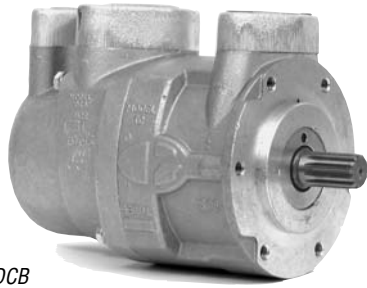

Series DCB

Description . . . . . Hydraulic Pumps  
 Flow Range . . . . . 3 To 12 & 12 To 24 GPM  
 Displacements . . . . . To 2.31 & To 4.62 C.I.R.  
 Maximum Pressure to . . . . . 1500 PSI  
 Maximum Speed to . . . . . 1800 RPM  
 Rotation . . . . . Optional  
 Construction . . . . . All Aluminum  
 Shipping Weight . . . . . 27 lbs.

## Performance Data

MODEL NO.	RPM	DELIVERY GPM @				HORSE POWER INPUT @			
		100 PSI	500 PSI	1000 PSI	1500 PSI	100 PSI	500 PSI	1000 PSI	1500 PSI
B-3	700	2.20	1.90	1.82	1.40	0.24	1.04	1.97	2.97
	900	2.84	2.57	2.40	2.02	0.33	1.34	2.58	3.78
	1200	3.79	3.49	3.30	2.94	0.49	1.83	3.43	4.97
	1500	4.75	4.44	4.14	3.83	0.69	2.33	4.28	6.14
	1800	5.68	5.36	5.00	4.74	0.91	2.85	5.14	7.34
B-6	500	2.80	2.45	2.25	1.80	0.19	1.14	2.18	3.25
	900	5.15	4.80	4.50	4.05	0.40	2.08	3.94	5.81
	1200	6.95	6.59	6.25	5.80	0.61	2.84	5.27	7.69
	1500	8.7	8.3	7.9	7.45	0.83	3.57	6.64	9.61
	1800	10.48	10.08	9.61	9.15	1.14	4.37	8.02	11.56
B-9	500	4.08	3.90	3.44	2.92	0.24	1.44	2.89	4.38
	900	7.50	7.23	6.82	6.22	0.54	2.68	5.22	7.86
	1200	10.10	9.80	9.40	8.74	0.82	3.67	6.96	10.47
	1500	12.62	12.25	11.85	11.21	1.16	4.71	8.85	13.08
	1800	15.15	14.75	14.35	13.7	1.63	5.82	10.76	15.84
B-12	500	5.35	5.05	4.73	4.25	0.30	1.74	3.59	5.42
	900	9.73	9.45	9.05	8.58	0.68	3.21	6.52	9.73
	1200	12.95	12.68	12.25	11.75	1.08	4.41	8.75	12.99
	1500	16.15	15.90	15.50	14.93	1.55	5.76	11.08	16.27
	1800	19.40	19.18	18.70	18.18	2.17	7.19	13.56	19.70
TC-12	500	5.0	4.1	3.7	2.7	0.33	1.70	3.53	5.30
	900	9.1	8.2	7.7	6.7	0.83	3.31	6.44	9.56
	1200	12.21	11.4	10.7	9.8	1.29	4.59	8.74	12.77
	1500	15.4	14.5	13.7	12.8	1.78	5.95	11.04	16.01
	1800	18.5	17.5	16.6	15.8	2.48	7.42	13.50	19.41
TC-16	500	6.9	6.4	5.9	5.0	0.42	2.32	4.73	7.12
	900	12.7	12.2	11.6	10.7	1.06	4.45	8.75	13.02
	1200	17.0	16.4	15.9	15.0	1.71	6.22	11.87	17.53
	1500	21.3	20.7	21.2	19.3	2.57	8.18	15.22	22.17
	1800	25.7	25.1	24.5	23.6	3.54	10.33	18.78	27.12
TC-20	500	8.2	7.7	7.1	6.2	0.61	2.50	5.25	7.89
	900	14.8	14.4	13.6	12.8	1.40	4.92	9.71	14.49
	1200	19.9	19.4	18.6	17.8	2.15	6.98	13.32	19.60
	1500	26.5	24.3	23.6	22.6	3.14	9.28	17.22	24.98
	1800	30.0	29.2	28.4	27.5	4.28	11.82	21.32	30.69
TC-24	500	9.7	9.1	8.3	7.4	0.76	2.80	5.92	9.06
	900	17.5	16.9	16.1	15.0	1.69	5.52	11.10	16.68
	1200	23.4	22.7	21.9	20.8	2.64	7.86	15.26	22.61
	1500	29.2	28.5	27.8	26.5	3.78	10.59	19.74	28.95
	1800	35.0	34.2	33.4	32.2	4.99	13.62	24.55	35.48

## How To Order

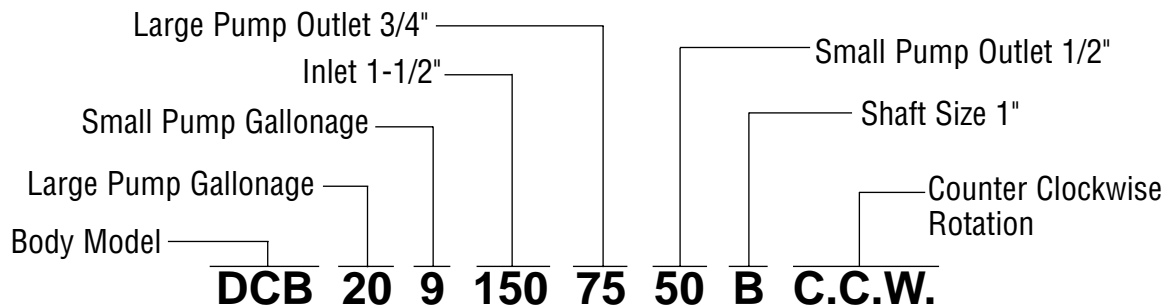

**VANE PUMPS**

(Includes High Speed Cam Rings).



TB Vane Pump

Order Code	Bill of Material #	Model	Approximate GPM @ 1200 PRM	Inlet NPT	Outlet NPT	Type* Shaft	Rotation
TB-3-75-50-K-CW	7243-036	TB	3	3/4"	1/2"	K	CW
TB-3-75-50-K-CCW	7243-037	TB	3	3/4"	1/2"	K	CCW
TB-6-75-50-K-CW	7243-025	TB	6	3/4"	1/2"	K	CW
TB-6-75-50-K-CCW	7243-026	TB	6	3/4"	1/2"	K	CCW
TB-9-100-75-K-CW	7243-012	TB	9	1"	3/4"	K	CW
TB-9-100-75-K-CCW	7243-013	TB	9	1"	3/4"	K	CCW
TB-12-100-75-K-CW	7243-001	TB	12	1"	3/4"	K	CW
TB-12-100-75-K-CCW	7243-002	TB	12	1"	3/4"	K	CCW



TC Vane Pump

TC-12-125-75-B-CW	7245-037	TC	12	1-1/4"	3/4"	B	CW
TC-12-125-75-B-CCW	7245-038	TC	12	1-1/4"	3/4"	B	CCW
TC-16-125-100-B-CW	7245-022	TC	16	1-1/4"	1"	B	CW
TC-16-125-100-B-CCW	7245-023	TC	16	1-1/4"	1"	B	CCW
TC-20-125-100-B-CW	7245-011	TC	20	1-1/4"	1"	B	CW
TC-20-125-100-B-CCW	7245-012	TC	20	1-1/4"	1"	B	CCW
TC-20-125-100-D-CCW	7245-019	TC	20	1-1/4"	1"	D	CCW
TC-24-125-100-B-CW	7245-001	TC	24	1-1/4"	1"	B	CW
TC-24-125-100-B-CCW	7245-002	TC	24	1-1/4"	1"	B	CCW



DCB Vane Pump

DCB-16-6-150-100-50-CCW	7247-018	DCB	16	6	1-1/2"	1"	1/2"	B	CCW
DCB-24-6-150-100-50-B-CCW	7247-038	DCB	24	6	1-1/2"	1"	1/2"	B	CCW
DCB-24-12-150-100-75-D-CCW	7247-071	DCB	24	12	1-1/2"	1"	3/4"	D	CCW
DCB-24-12-150-100-75-B-CW	7247-001	DCB	24	12	1-1/2"	1"	3/4"	B	CW
DCB-24-12-150-100-75-B-CCW	7247-002	DCB	24	12	1-1/2"	1"	3/4"	B	CCW

\*Shaft Description "B" - 1" Diameter with keyway.  
 "D" - 7/8" Diameter, SAE 13 spline.  
 "K" - 3/4" Diameter with keyway.



## Option Kits

Order Code	Bill of Material #	Description
K-TB-FM	8650-212	TB Foot Mount
K-TC-FM	8650-213	TC or DCB Foot Mount
K-TB-I-75	8650-214	3/4" NPT Intake Flange
K-TB-I-100	8650-215	1" NPT Intake Flange
K-TB-O-50	8650-216	1/2" NPT Outlet Flange
K-TB-O-75	8650-217	3/4" NPT Outlet Flange
K-TC-I-125	8650-221	1-1/4" NPT Intake Flange
K-TC-O-75	8650-218	3/4" NPT Outlet Flange
K-TC-O-100	8650-219	1" NPT Outlet Flange
K-DCB-I-150	8650-220	1-1/2" NPT Inlet Flange
K-DCB-OC-100	8650-222	1" NPT Outlet Flange (C End)
K-DCB-OB-75	8650-223	3/4" NPT Outlet Flange (B End)

NOTE: Foot Mount Kits contain all necessary bolts for mounting.  
 Flange Kits do not include bolts.  
 Flange Kits include Seals.

## Rotor (Cam) Ring

High Speed Cam Rings are furnished.

### TB or B End of DCB

Order Code	Bill of Material #	Approx. GPM @ 1200 RPM and 1500 PSI
K-TB-3	8650-224	3
K-TB-6	8650-225	6
K-TB -9	8650-226	9
K-TB-12	8650-227	12

### TC or C End of DCB

Order Code	Bill of Material #	Approx. GPM @ 1200 RPM and 1500 PSI
K-TC-12	8650-230	12
K-TC-16	8650-231	16
K-TC-20	8650-232	20
K-TC-24	8650-178	24





Series P16

Description . . . . . Gear Pumps  
 Flow Range . . . . . TO 38 GPM  
 Displacements . . . . . TO 3.904 C.I.R.  
 Maximum Pressure to . . . . . 3000 PSI  
 Maximum Speed to . . . . . 3600 RPM  
 Rotation . . . . . A or C  
 Bearings . . . . . Journal  
 Construction . . . . . Cast Iron Gear Plate with Aluminum Flange and Cover Plate

## Performance Data

PUMP SIZES	DISPLACEMENT/REVOLUTION (Theoretical)					MAXIMUM PRESSURE		MAXIMUM SPEED
	US Gallons	Cubic Inches	Liters	Cubic Centimeters	Imperial Gallons	PSI	BAR	RPM
P16 - 45	.0038	.878	.0144	14.388	.0031	3000	207	3600
P16 - 65	.0055	1.270	.0208	20.812	.0045	3000	207	3600
P16 - 85	.0072	1.663	.0273	27.252	.0059	3000	207	3400
P16 - 100	.0085	1.964	.0321	32.184	.0070	3000	207	3300
P16 - 115	.0097	2.241	.0367	36.723	.0080	3000	207	3100
P16 - 150	.0127	2.934	.0481	48.080	.0105	3000	207	2800
P16 - 180	.0152	3.511	.0575	57.535	.0126	2200	152	2500
P16 - 200	.0169	3.902	.0639	63.942	.0140	2000	138	2200

All data based on SAE 10W oil at 150°F.  
 Available with Viton Seals for use with phosphate ester base fluids.

## How To Order

'A' denotes counterclockwise rotation  
 'C' denotes clockwise rotation  
 When viewed from drive shaft end

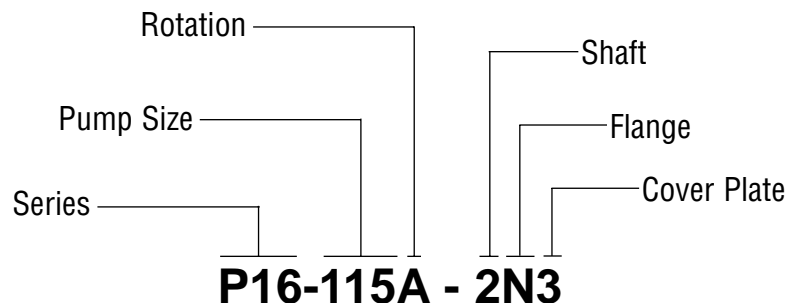

Note: Add prefix 'V' to pump model number (VP16-) when ordering pumps with Viton Seals for use with phosphate ester base fluids.

## Shafts Available

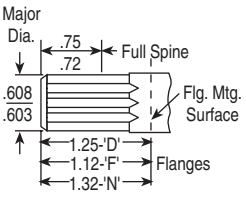
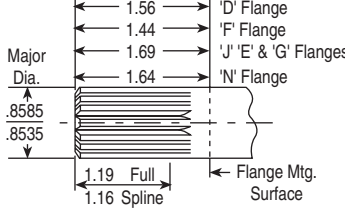
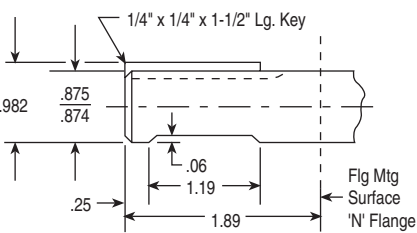
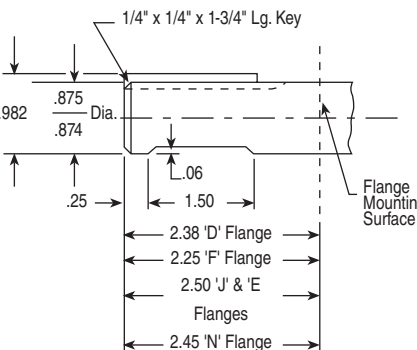
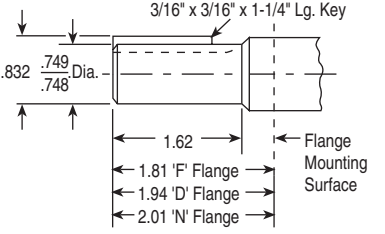
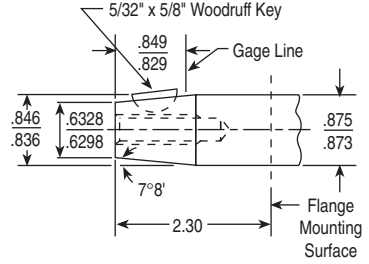
<p><b>1</b> <b>5/8" Dia. 9 Tooth Spline Flat Root Side Fit</b> Torque Limit 52 Lbs. Ft.</p>  <p>Spline Data Diametral Pitch ..... 16/32 Pressure Angle ..... 30° No. Of Teeth ..... 9 Minor Dia. .... .472-.483</p>	<p><b>2</b> <b>7/8" Dia. 13 Tooth Spline Flat Root Side Fit</b> Torque Limit 184 Lbs. Ft.</p>  <p>Spline Data Diametral Pitch ..... 16/32 Pressure Angle ..... 30° No. Of Teeth ..... 13 Minor Dia. .... .722-.733</p>	<p><b>3</b> <b>7/8" Straight Shaft for Piggy-Back</b> Torque Limit 184 Lbs. Ft.</p> 
<p><b>5</b> <b>7/8" Straight Shaft</b> Torque Limit 184 Lbs. Ft.</p> 	<p><b>6</b> <b>3/4" Straight Shaft</b> Torque Limit 105 Lbs. Ft.</p> 	<p><b>9</b> <b>7/8" Tapered Shaft</b> Torque Limit 184 Lbs. Ft.</p> 

## Flanges Available

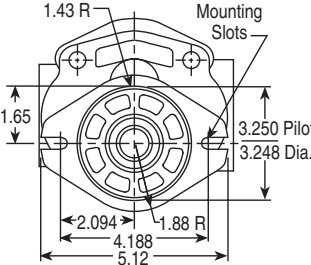
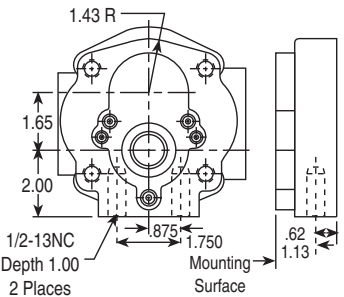
<p><b>D</b> <b>SAE 'A' 2-Bolt</b></p> 	<p><b>F</b> <b>Pad Mount</b></p> 
---	---

## Flanges Available

<p><b>N</b> SAE 'B' 2-Bolt</p>	<p><b>S</b> P.T.O. Direct Mount Available with No. 2 Shaft Only</p>
<p><b>T</b> P.T.O. Direct Mount T19C Trans Available with No. 2 Shaft Only</p>	

## Cover Plates Available

<p><b>1</b> Rear Ported Straight Thread</p>	<p><b>2</b> Rear Ported NPT</p> <p><b>7</b> Rear Ported BSPT</p>	<p><b>3</b> Side Ported SAE 4-Bolt</p> <p>Discharge Side Suction Side</p> <p>SAE 4-Bolt NPT Connectors Are Available. See Accessory Section</p>
<p><b>4</b> Side Ported NPT</p> <p><b>8</b> Side Ported BSPT</p>	<p><b>5</b> Side Ported Straight Thread SAE 12 Discharge</p> <p><b>9</b> Side Ported Straight Thread SAE 16 Discharge</p>	<p><b>6</b> Rear Ported Straight Thread</p>

\*Suction Port Adaptor Fitting to Reduce SAE 20 to SAE 16 (1-5/16-12UN-2B) Order Kit 15369

## Dimensional Data

### Mounting Dimensions

PUMP SIZES	FLANGE TYPE												SHIPPING WEIGHTS (Approx.)	
	D				E				F					
	A		B		A		B		A		B			
	IN	MM	IN	MM	IN	MM	IN	MM	IN	MM	IN	MM		
P16 - 45	3.54	89.9	4.55	115.6	4.66	118.4	5.67	144.1	3.66	92.9	4.67	118.6	12	5.5
P16 - 65	3.75	95.3	4.77	121.2	4.88	123.6	5.89	149.6	3.88	98.6	4.89	124.2	13	5.9
P16 - 85	3.97	100.9	4.98	126.5	5.09	129.3	6.10	154.9	4.09	103.6	5.10	129.5	14	6.4
P16 - 100	4.13	104.9	5.14	130.6	5.25	133.3	6.26	159.0	4.25	107.9	5.26	133.6	15	6.8
P16 - 115	4.29	108.9	5.30	134.6	5.41	137.4	6.42	163.1	4.41	112.0	5.42	137.7	16	7.3
P16 - 150	4.66	118.4	5.67	144.1	5.78	146.8	6.79	172.5	4.78	121.4	5.79	147.1	17	7.7
P16 - 180	4.98	126.5	5.99	152.2	6.10	154.9	7.11	180.6	5.10	129.5	6.11	155.2	19	8.6
P16 - 200	5.19	131.8	6.20	157.5	6.31	160.3	7.32	185.9	5.31	134.9	6.32	160.5	20	9.1

### Mounting Dimensions

PUMP SIZES	FLANGE TYPE												SHIPPING WEIGHTS (Approx.)	
	G & J				N				S & T					
	A		B		A		B		A		B			
	IN	MM	IN	MM	IN	MM	IN	MM	IN	MM	IN	MM		
P16 - 45	4.66	118.4	5.67	144.1	3.47	88.1	4.48	113.8	5.22	132.6	6.23	158.2	12	5.5
P16 - 65	4.88	123.6	5.89	149.6	3.69	93.7	4.70	119.4	5.44	138.2	6.45	163.8	13	5.9
P16 - 85	5.09	129.3	6.10	154.9	3.90	99.1	4.91	124.7	5.65	143.5	6.66	169.2	14	6.4
P16 - 100	5.25	133.3	6.26	159.0	4.06	103.1	5.07	128.8	5.81	147.6	6.82	173.2	15	6.8
P16 - 115	5.41	137.4	6.42	163.1	4.22	107.2	5.23	132.8	5.97	151.6	6.98	177.3	16	7.3
P16 - 150	5.78	146.8	6.79	172.5	4.59	116.6	5.60	142.2	6.34	161.0	7.35	186.7	17	7.7
P16 - 180	6.10	154.9	7.11	180.6	4.91	124.7	5.92	150.4	6.66	169.2	7.67	194.8	19	8.6
P16 - 200	6.31	160.3	7.32	185.9	5.12	130.1	6.13	155.7	6.87	174.5	7.88	200.1	20	9.1

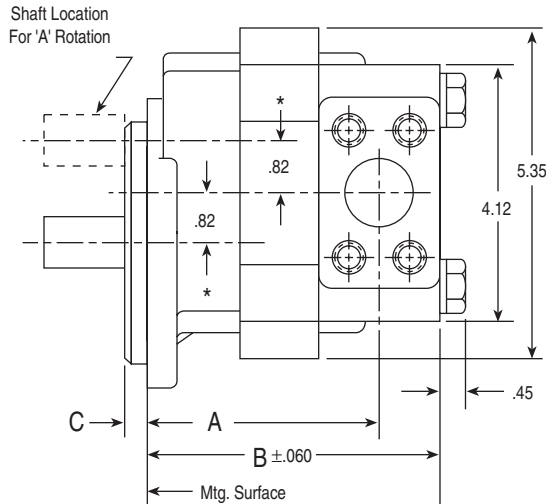

### C Dimensions

FLANGE TYPE	IN	MM
D	.250	6.35
E	.187	4.74
F	—	—
G	.250	6.35
J	.250	6.35
N	.375	9.52
S	.200	5.08
T	.200	5.08

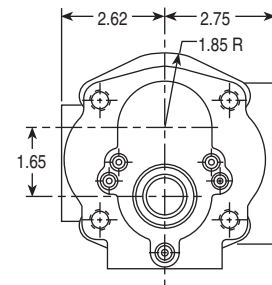

\*These dimensions locate  $\phi$  of bolt pattern only.

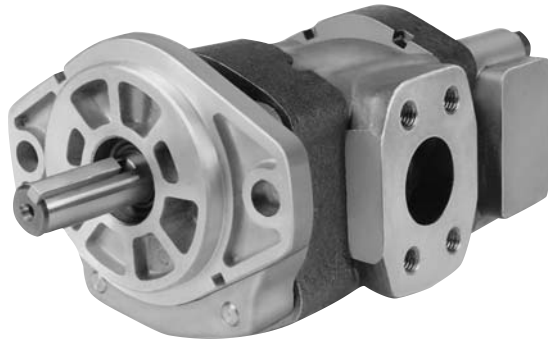

Series TP16

Description . . . . . Gear Pumps (Two-place)  
 Flow Range . . . . . To 32 GPM Per Section  
 Displacements . . . . . To 3.904 C.I.R.  
 Maximum Pressure to . . . . . 3000 PSI  
 Maximum Speed to . . . . . 3100 RPM  
 Rotation . . . . . A or C  
 Bearings . . . . . Journal  
 Construction . . . . . Cast Iron Gear Plates with Aluminum Flange, Connector and Cover Plates

## Performance Data

PUMP SIZES	DISPLACEMENT/REVOLUTION (Theoretical)					MAXIMUM PRESSURE		MAXIMUM SPEED (RPM)	
	US Gallons	Cubic Inches	Liters	Cubic Centimeters	Imperial Gallons	PSI	BAR	Single	Tandem
	TP16 - 45	.0038	.878	.0144	14.388	.0031	3000	207	3600
TP16 - 65	.0055	1.270	.0208	20.812	.0045	3000	207	3600	3000
TP16 - 85	.0072	1.663	.0273	27.252	.0059	3000	207	3400	2900
TP16 - 100	.0085	1.964	.0321	32.184	.0070	3000	207	3300	2800
TP16 - 115	.0097	2.241	.0367	36.723	.0080	3000	207	3100	2600
TP16 - 150	.0127	2.934	.0481	48.080	.0105	3000	207	2800	2400
TP16 - 180	.0152	3.511	.0575	57.535	.0126	2200	152	2500	2100
TP16 - 200	.0169	3.904	.0639	63.942	.0140	2000	138	2200	1900

Note: For best inlet conditions, place largest displacement section in the rear position and use both inlet ports.  
 All data based on SAE 10W oil at 150°F.  
 Available with Viton Seals for use with phosphate ester base fluids.

## How To Order

'A' denotes counterclockwise rotation  
 'C' denotes clockwise rotation  
 When viewed from drive shaft end

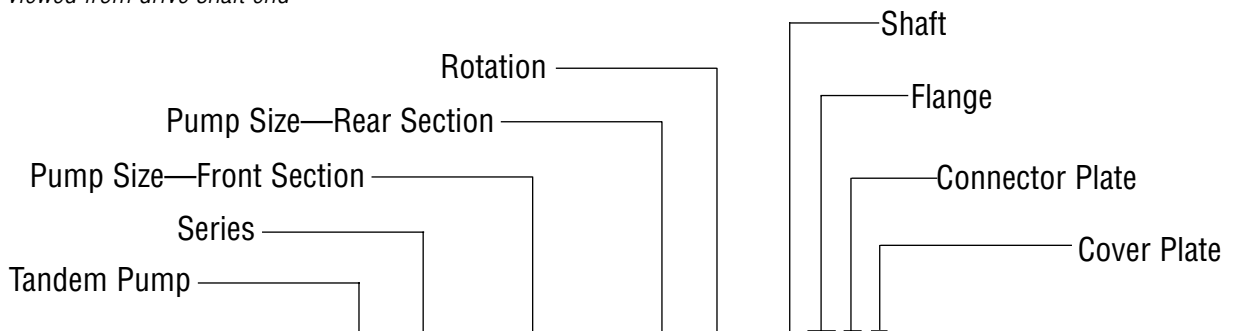

**TP16 - 150 - 100A - 5N33**

Note: Add prefix 'V' to pump model number (VTP16-) when ordering pumps with Viton Seals for use with phosphate ester base fluids.

## Shafts Available

<p><b>2</b> <b>7/8" Dia. 13 Tooth Spline Flat Root Side Fit.</b> Torque Limit 184 Lbs. Ft.</p> <p><b>Spline Data</b></p> <table style="width: 100%; border-collapse: collapse;"> <tr><td>Diametral Pitch</td><td>16/32</td></tr> <tr><td>Pressure Angle</td><td>30°</td></tr> <tr><td>No. Of Teeth</td><td>13</td></tr> <tr><td>Minor Dia.</td><td>.722-.733</td></tr> </table>	Diametral Pitch	16/32	Pressure Angle	30°	No. Of Teeth	13	Minor Dia.	.722-.733	<p><b>5</b> <b>7/8" Straight Shaft</b> Torque Limit 184 Lbs. Ft.</p>
Diametral Pitch	16/32								
Pressure Angle	30°								
No. Of Teeth	13								
Minor Dia.	.722-.733								

## Mounting Flanges Available

<p><b>D</b> <b>SAE 'A' 2-Bolt</b></p>	<p><b>F</b> <b>Pad Mount</b></p>
<p><b>N</b> <b>SAE 'B' 2-Bolt</b></p>	<p><b>S</b> <b>P.T.O. Direct Mount</b> Available with No. 2 Shaft Only</p>



## Discharge Ports for Connector Plate and Cover Plate

<p><b>3</b> SAE 4-Bolt</p> <p>3/4" SAE 4-Bolt Conn. SAE 4-Bolt NPT Connectors Are Available. See Accessory Section</p>	<p><b>4</b> NPT-Pipe Thread</p> <p><b>8</b> BSPT-Pipe Thread</p> <p>3/4-14 PT</p>	<p><b>5</b> SAE 12 Straight Thread</p> <p>1-1/16-12UN-2B</p>	<p><b>9</b> SAE 16 Straight Thread</p> <p>1-5/16-12UN-2B</p>
--	---	--	--

## Dimensional Data

### PD Factors

The maximum size and number of sections of a tandem pump for a given application is limited to the torque capability of the input drive shaft and the spline coupling between the sections. To determine this capability, a "PD Factor" is used:

Maximum allowable PD for the 7/8" drive shaft is 53.  
Maximum allowable PD for a coupling is also 53.

When: P = PSI (The relief valve setting of each individual section).  
D = Displacement (In U.S. gallons per revolution of each individual section).

Example: Assume a two-place pump TP16-150 — 150 with front and rear sections on pressure at the same time at 2000 PSI:

- A. Drive Shaft:  
 $PD = (2000) (.0127) + (2000) (.0127) = 50.8$  vs. 53. Capability is OK
- B. Coupling between front and center sections:  
 $PD = (2000) (.0127) = 25.4$  vs. 53. Capability is OK.

### Flange Dimensions

FLANGE TYPE	E		F	
	IN	MM	IN	MM
D	.250	6.35	1.62	41.15
E	.187	4.75	2.75	69.85
F	—	—	1.75	44.45
J	.250	6.35	2.75	69.85
N	.375	9.52	1.55	38.10
S	.200	5.08	3.31	84.07

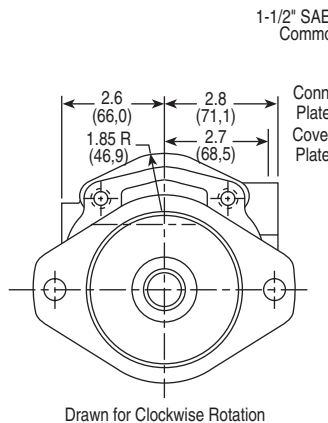
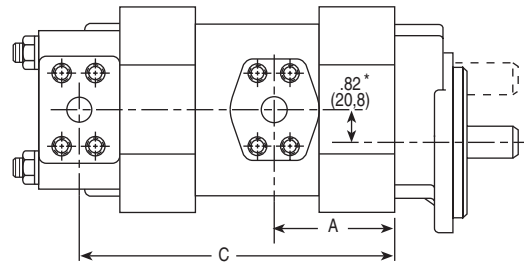

\*These dimensions locate  $\varnothing$  of bolt pattern only.

## Dimensional Data

*Mounting Dimensions*

PUMP SIZES	A		B		C		D		SHIPPING WEIGHTS (Approx.)	
	IN	MM	IN	MM	IN	MM	IN	MM	lbs.	kgs.
	TP16-45-45	1.89	48.01	2.42	61.47	5.90	149.9	6.91	175.5	26
TP16-65-45	2.11	53.59	2.64	67.06	6.11	155.2	7.12	180.9	28	12.7
TP16-65-65	2.11	53.59	2.64	67.06	6.33	160.8	7.34	186.4	30	13.6
TP16-85-45	2.32	58.93	2.85	72.39	6.33	160.8	7.34	186.4	31	14.1
TP16-85-65	2.32	58.93	2.85	72.39	6.54	166.1	7.55	191.8	33	15.0
TP16-85-85	2.32	58.93	2.85	72.39	6.76	171.7	7.77	197.4	35	15.9
TP16-100-45	2.48	62.99	3.01	76.45	6.49	164.9	7.50	190.5	34	15.4
TP16-100-65	2.48	62.99	3.01	76.45	6.70	170.2	7.71	195.8	36	16.3
TP16-100-85	2.48	62.99	3.01	76.45	6.92	175.8	7.93	201.4	38	17.2
TP16-100-100	2.48	62.99	3.01	76.45	7.08	179.8	8.09	205.5	39	17.7
TP16-115-45	2.64	67.06	3.17	80.52	6.65	168.9	7.66	194.6	39	17.7
TP16-115-65	2.64	67.06	3.17	80.52	6.86	174.2	7.87	199.9	41	18.6
TP16-115-85	2.64	67.06	3.17	80.52	7.08	179.8	8.09	205.5	43	19.5
TP16-115-100	2.64	67.06	3.17	80.52	7.24	183.9	8.25	209.6	44	20.0
TP16-115-115	2.64	67.06	3.17	80.52	7.40	188.0	8.41	213.6	46	20.9
TP16-150-45	3.01	76.45	3.54	89.92	7.02	178.3	8.03	204.0	44	20.0
TP16-150-65	3.01	76.45	3.54	89.92	7.23	183.6	8.24	209.3	47	21.3
TP16-150-85	3.01	76.45	3.54	89.92	7.45	189.2	8.46	214.9	49	22.2
TP16-150-100	3.01	76.45	3.54	89.92	7.61	193.3	8.62	219.0	50	22.7
TP16-150-115	3.01	76.45	3.54	89.92	7.77	197.4	8.78	223.0	52	23.6
TP16-150-150	3.01	76.45	3.54	89.92	8.14	206.8	9.15	232.4	54	24.5
TP16-180-45	3.33	84.58	3.86	98.04	7.34	186.4	8.35	212.1	52	23.6
TP16-180-65	3.33	84.58	3.86	98.04	7.55	191.8	8.56	217.4	54	24.5
TP16-180-85	3.33	84.58	3.86	98.04	7.77	197.4	8.78	223.0	56	25.4
TP16-180-100	3.33	84.58	3.86	98.04	7.93	201.4	8.94	227.1	57	25.9
TP16-180-115	3.33	84.58	3.86	98.04	8.09	205.5	9.10	231.1	59	26.8
TP16-180-150	3.33	84.58	3.86	98.04	8.46	214.9	9.47	240.5	61	27.7
TP16-180-180	3.33	84.58	3.86	98.04	8.78	223.0	9.79	248.7	63	28.6
TP16-200-45	3.55	90.17	4.08	103.6	7.55	191.8	8.57	217.7	60	27.2
TP16-200-65	3.55	90.17	4.08	103.6	7.76	197.1	8.77	222.8	62	28.1
TP16-200-85	3.55	90.17	4.08	103.6	7.98	202.7	8.99	228.4	64	29.0
TP16-200-100	3.55	90.17	4.08	103.6	8.14	206.8	9.15	232.4	65	29.5
TP16-200-115	3.55	90.17	4.08	103.6	8.30	210.8	9.31	236.5	67	30.4
TP16-200-150	3.55	90.17	4.08	103.6	8.67	220.2	9.68	245.9	69	31.3
TP16-200-180	3.55	90.17	4.08	103.6	8.99	228.4	10.00	254.0	71	32.2
TP16-200-200	3.55	90.17	4.08	103.6	9.20	233.7	10.21	259.3	73	33.1

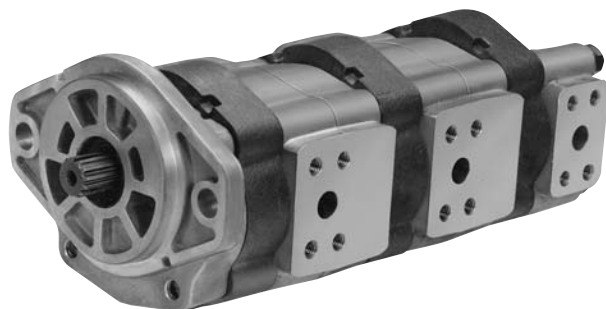

Series TP16

Description . . . . . Gear Pumps (Three-place)  
 Flow Range . . . . . To 32 GPM Per Section  
 Displacements . . . . . To 3.904 C.I.R.  
 Maximum Pressure to . . . . . 3000 PSI  
 Maximum Speed to . . . . . 3100 RPM  
 Rotation . . . . . A or C  
 Bearings . . . . . Journal  
 Construction . . . . . Cast Iron Gear Plates with Aluminum Flange, Connector and Cover Plates

## Performance Data

PUMP SIZES	DISPLACEMENT/REVOLUTION (Theoretical)					MAXIMUM PRESSURE		MAXIMUM SPEED
	US Gallons	Cubic Inches	Liters	Cubic Centimeters	Imperial Gallons	PSI	BAR	RPM
	P16 - 45	.0038	.878	.0144	14.388	.0031	3000	207
P16 - 65	.0055	1.270	.0208	20.812	.0045	3000	207	3000
P16 - 85	.0072	1.663	.0273	27.252	.0059	3000	207	2900
P16 - 100	.0085	1.964	.0321	32.184	.0070	3000	207	2800
P16 - 115	.0097	2.241	.0367	36.723	.0080	3000	207	2600
P16 - 150	.0127	2.934	.0481	48.080	.0105	3000	207	2400
P16 - 180	.0152	3.511	.0575	57.535	.0126	2200	152	2100
P16 - 200	.0169	3.904	.0639	63.942	.0140	2000	138	1900

Note: Three-place pumps assembled from maximum displacement size sections should be checked for operating inlet conditions. Inlet vacuum should not exceed 5" Hg. @ normal speed and temperature. If "PD Factor" is not exceeded, place the largest displacement section in the rear position and use all inlet ports.  
 All data based on SAE 10W oil at 150°F.  
 Available with Viton Seals for use with phosphate ester base fluids.

## How To Order

'A' denotes counterclockwise rotation  
 'C' denotes clockwise rotation

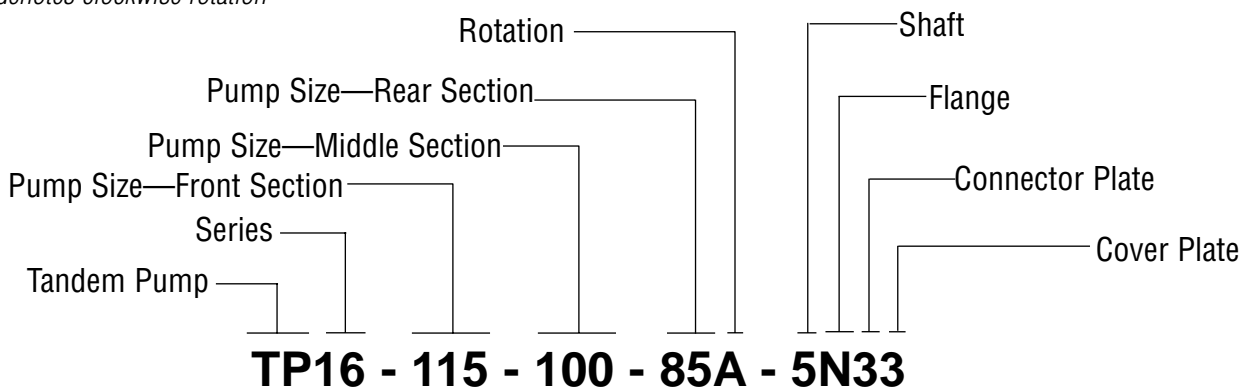

Note: The average shipping weight will range between 40 and 80 pounds (18.1-36.3 kgs.).  
 Note: Add prefix 'V' to pump model number (VTP16-) when ordering pumps with Viton Seals for use with phosphate ester base fluids.

## Shafts Available

<p><b>2</b> 7/8" Dia. 13 Tooth Spline Flat Root Side Fit Torque Limit 184 Lbs./Ft.</p> <p><b>Spline Data</b>          Diametral Pitch . . . . . 16/32          Pressure Angle . . . . . 30°          No. Of Teeth . . . . . 13          Minor Dia. . . . . .722-.733</p>	<p><b>5</b> 7/8" Straight Shaft Torque Limit 184 Lbs./Ft.</p>
--	---

## Mounting Flanges Available

<p><b>D</b> SAE 'A' 2-Bolt</p>	<p><b>F</b> Pad Mount</p>
<p><b>N</b> SAE 'B' 2-Bolt</p>	<p><b>S</b> P.T.O. Direct Mount Available with No. 2 Shaft Only SAE 'B' 4-Bolt</p>

## Discharge Ports for Connector Plate and Cover Plate

<p><b>3</b> SAE 4-Bolt</p> <p>3/4" SAE 4-Bolt Conn. SAE 4-Bolt NPT Connectors Are Available. See Accessory Section</p>	<p><b>4</b> NPT-Pipe Thread</p> <p><b>8</b> BSPT-Pipe Thread</p> <p>3/4-14 PT</p>	<p><b>5</b> SAE 12 Straight Thread</p> <p>1-1/16-12UN-2B</p>	<p><b>9</b> SAE 16 Straight Thread</p> <p>1-5/16-12UN-2B</p>
--	---	--	--

\*These dimensions locate  $\phi$  of bolt pattern only.

## Dimensional Data

To Determine Overall Pump Length  
Add together the dimensions that apply to the pump you are considering

- A = \_\_\_\_\_ Shaft Extension
- B = \_\_\_\_\_ Flange Length
- C = \_\_\_\_\_ Front Gear Plate Length
- D =  $\frac{3.12 \text{ in.}}{79.25 \text{ mm}}$  Connector Plate Length
- E = \_\_\_\_\_ Center Gear Plate Length
- F =  $\frac{3.12 \text{ in.}}{79.25 \text{ mm}}$  Connector Plate Length
- G = \_\_\_\_\_ Rear Gear Plate Length
- H =  $\frac{2.06 \text{ in.}}{52.32 \text{ mm}}$  Cover Plate Length
- J =  $\frac{.75 \text{ in.}}{19.05 \text{ mm}}$  Stud Extension
- \_\_\_\_\_ Total = Overall Length

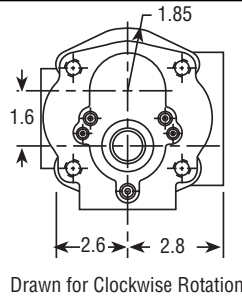

### Flange Dimensions

FLANGE TYPE	'B'	'K'
D	1.62	.250
E	2.75	.187
F	1.75	-
J	2.75	.250
N	1.55	.375
S	3.31	.200

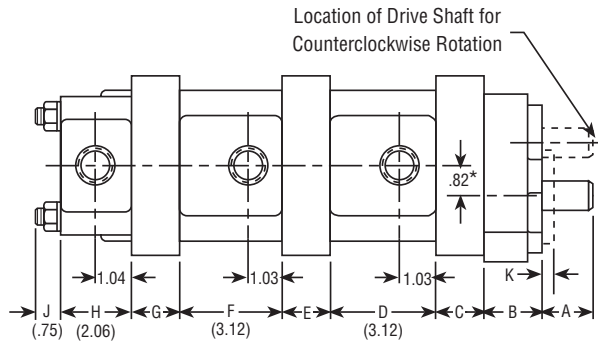

### Gear Plate Length

PUMP SIZE	IN	MM
-45	.86	21.84
-65	1.07	27.18
-85	1.29	32.77
-100	1.45	36.83
-115	1.61	40.89
-150	1.98	50.29
-180	2.30	58.42
-200	2.51	63.75

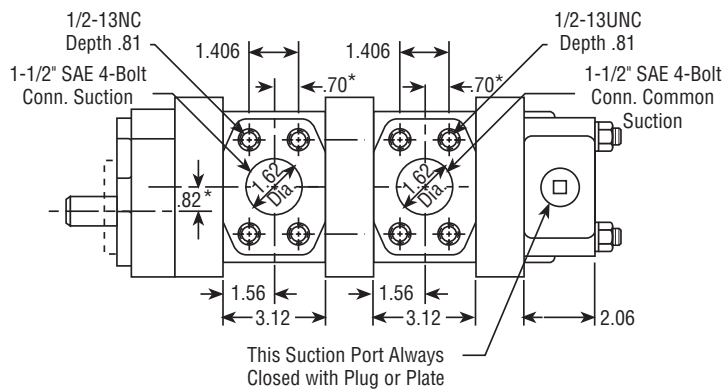

\*These dimensions locate  $\phi$  of bolt pattern only.

## Dimensional Data

### PD Factors

The maximum size and number of sections of a tandem pump for a given application is limited to the torque capability of the input drive shaft and the spline coupling between the sections. To determine this capability, a "PD Factor" is used:

*Maximum allowable PD for the 7/8" drive shaft is 53.*

*Maximum allowable PD for a coupling is also 53.*

*When:* P = PSI (The relief valve setting of each individual section).  
D = Displacement (In U.S. gallons per revolution of each individual section).

*Example:* Assume a three-place pump TP16-150-150-100 with front and center sections on pressure at the same time at 2000 PSI, and with the rear section on pressure at 1500 PSI but not at the same time as the front and center sections:

- A. Drive Shaft:  
(1)  $PD = (2000) (.0127) + (2000) (.0127) = 50.8$  vs. 53. Capability is OK  
(2)  $PD = (1500) (.0085) = 12.7$  vs. 53. Capability is OK.
- B. Coupling between front and center sections:  
 $PD = (2000) (.0127) = 25.4$  vs. 53. Capability is OK.
- C. Coupling between center and rear sections:  
 $PD = (1500) (.0085) = 12.7$  vs. 53. Capability is OK.

*Note:* For purpose of illustration, assume all three pump sections to be on pressure at the same time.

- A. Drive Shaft:  
 $PD = (2000) (.0127) + (2000) (.0127) + (1500) (.0085) = 63.5$  vs. 53.  
Capability is not OK

Because the PD Factor for the shaft is 53, operating all three sections at the same time (to relief valve pressure) would exceed the torque capability of the drive shaft.

- B. Coupling between front and center sections:  
 $PD = (2000) (.0127) + (1500) (.0085) = 35.1$  vs. 53. Capability is OK

Remember also that the PD factor for the coupling is 53. If the center and rear sections are on pressure at the same time, the coupling between the front and center sections must transmit the torque for the center and rear sections.

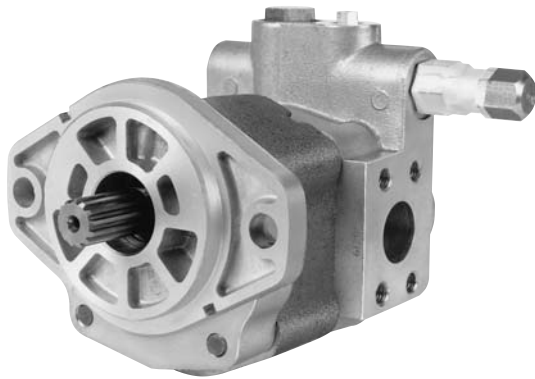

Series PVP16

Description . . . . . Priority Valve Gear Pumps  
 Pump Flow Range . . . . . To 38 GPM  
 Priority Flow Range . . . . . 2 to 10 GPM Standard  
 Displacements . . . . . To 3.904 C.I.R.  
 Maximum Pressure to . . . . . 3000 PSI  
 Maximum Speed to . . . . . 3600 RPM  
 Rotation . . . . . A or C  
 Bearings . . . . . Journal  
 Construction . . . . . Cast Iron Gear Plate with  
 Aluminum Flange and Cover (Valve) Plate

## Performance Data

PUMP SIZES	DISPLACEMENT/REVOLUTION (Theoretical)					MAXIMUM PRESSURE		MAXIMUM SPEED
	US Gallons	Cubic Inches	Liters	Cubic Centimeters	Imperial Gallons	PSI	BAR	RPM
	PVP16 - 45	.0038	.878	.0144	14.388	.0031	3000	207
PVP16 - 65	.0055	1.270	.0208	20.812	.0045	3000	207	3600
PVP16 - 85	.0072	1.663	.0273	27.252	.0060	3000	207	3400
PVP16 - 100	.0085	1.964	.0321	32.184	.0070	3000	207	3300
PVP16 - 115	.0097	2.241	.0367	36.723	.0080	3000	207	3100
PVP16 - 150	.0127	2.934	.0481	48.080	.0105	3000	207	2800
PVP16 - 180	.0152	3.511	.0575	57.535	.0125	2200	152	2500
PVP16 - 200	.0169	3.904	.0639	63.942	.0140	2000	138	2500

All data based on SAE 10W oil at 150°F.  
 Available with Viton Seals for use with phosphate ester base fluids.

## How To Order

'A' denotes counterclockwise rotation  
 'C' denotes clockwise rotation  
 When viewed from drive shaft end

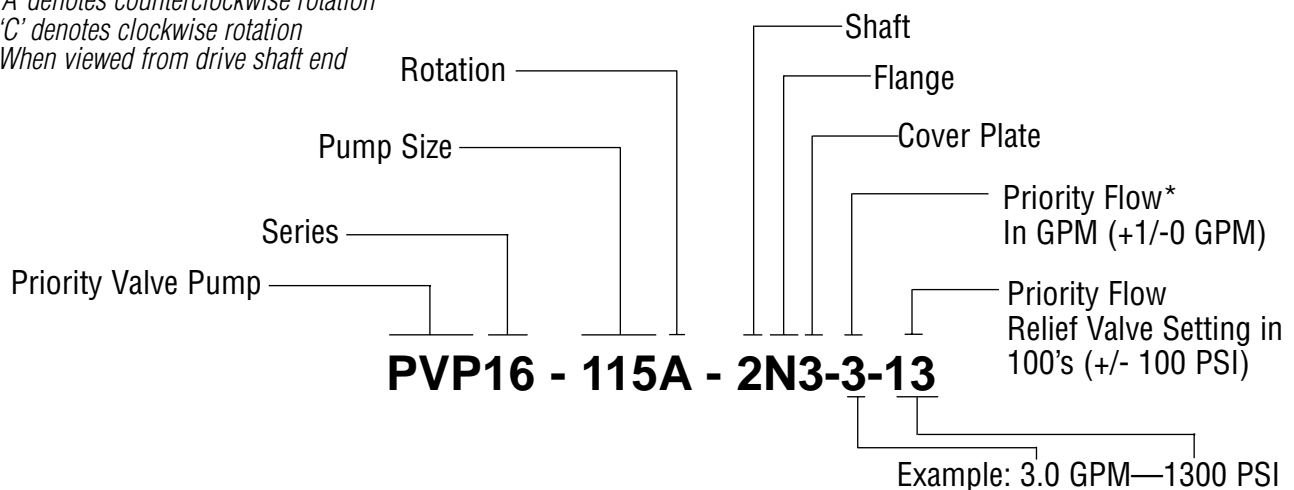

\*Consult factory for priority flows over 10 GPM.

Note: Add prefix 'V' to pump model number (VPVP16-) when ordering pumps with Viton Seals for use with phosphate ester base fluids.

## Shafts Available

<p><b>2</b> <b>7/8" Dia. 13 Tooth Spline Flat Root Side Fit</b> Torque limit 184 Lbs. Ft.</p> <p><b>Spline Data</b>          Diametral Pitch ..... 16/32          Pressure Angle ..... 30°          No. Of Teeth ..... 13          Minor Dia. .... .722-.733</p>	<p><b>5</b> <b>7/8" Straight Shaft</b> Torque limit 184 Lbs. Ft.</p>	<p><b>6</b> <b>3/4" Straight Shaft</b> Torque limit 105 Lbs. Ft. Available on -45 through -115 sizes only</p>
--	--	---

## Mounting Flanges Available

<p><b>D</b> <b>SAE 'A' 2-Bolt</b></p>	<p><b>F</b> <b>Pad Mount</b></p>
<p><b>N</b> <b>SAE 'B' 2-Bolt</b></p>	<p><b>S</b> <b>P.T.O. Direct Mount</b> Available with No.2 Shaft Only</p>



## Cover Plates Available

### 3 Side Ported SAE 4-Bolt

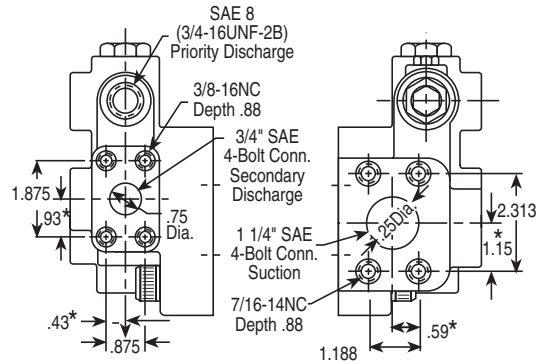

SAE 4-Bolt NPT Connectors Are Available. See Accessory Section

### 5 Side Ported Straight Thread

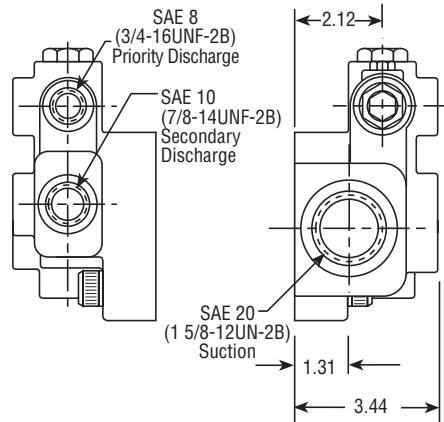

### 6 Rear Ported Straight Thread

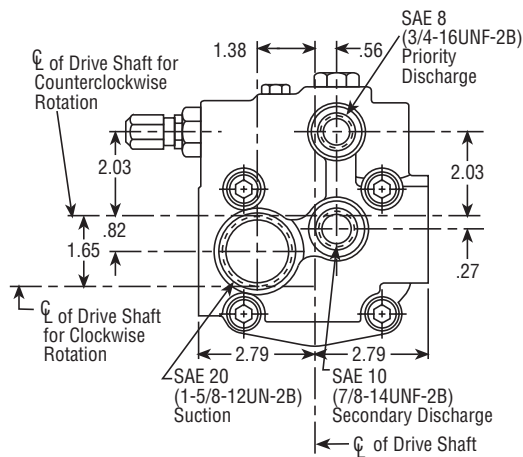

\*These dimensions locate  $\phi$  of bolt pattern only.

**Dimensional Data**

*Mounting Dimensions*

PUMP SIZES	FLANGE TYPE									SHIPPING WEIGHTS (Approx.)	
	D			E & J			F			lbs.	kgs.
	A	B	C	A	B	C	A	B	C		
PVP16 - 45	3.79	4.60	5.92	4.92	5.73	7.05	3.92	4.73	6.05	13	5.9
PVP16 - 65	4.00	4.81	6.13	5.13	5.94	7.26	4.13	4.94	6.26	14	6.4
PVP16 - 85	4.22	5.03	6.35	5.35	6.16	7.48	4.35	5.16	6.48	15	6.8
PVP16 - 100	4.38	5.19	6.51	5.51	6.32	7.64	4.51	5.32	6.64	16	7.3
PVP16 - 115	4.54	5.35	6.67	5.67	6.48	7.80	4.67	5.48	6.80	17	7.7
PVP16 - 150	4.91	5.72	7.04	6.04	6.85	8.17	5.04	5.85	7.17	18	8.2
PVP16 - 180	5.23	6.04	7.36	6.36	7.17	8.49	5.36	6.17	7.49	20	9.1
PVP16 - 200	5.44	6.25	7.57	6.57	7.38	8.70	5.57	6.38	7.70	21	9.5

*Mounting Dimensions*

PUMP SIZES	FLANGE TYPE						SHIPPING WEIGHTS (Approx.)	
	N			S			lbs.	kgs.
	A	B	C	A	B	C		
PVP16 - 45	3.67	4.48	5.80	5.48	6.29	7.61	13	5.9
PVP16 - 65	3.88	4.69	6.01	5.69	6.50	7.82	14	6.4
PVP16 - 85	4.10	4.91	6.23	5.91	6.72	8.04	15	6.8
PVP16 - 100	4.26	5.07	6.39	6.07	6.88	8.20	16	7.3
PVP16 - 115	4.42	5.23	6.55	6.23	7.04	8.36	17	7.7
PVP16 - 150	4.79	5.60	6.92	6.60	7.41	8.73	18	8.2
PVP16 - 180	5.11	5.92	7.24	6.92	7.73	9.05	20	9.1
PVP16 - 200	5.32	6.13	7.45	7.13	7.94	9.26	21	9.5

*D Dimensions*

FLANGE TYPE	D	
	IN	MM
D	.250	6.35
E	.187	4.75
F		
J	.250	6.35
N	.375	9.52
S	.250	6.35

*Priority Flow*

CAT. NO	CAT. NO	CAT. NO	CAT. NO	CAT. NO	CAT. NO	CAT. NO	CAT. NO
2	3	4	5	6	7	8	9
2 to 3 GPM	3 to 4 GPM	4 to 5 GPM	5 to 6 GPM	6 to 7 GPM	7 to 8 GPM	8 to 9 GPM	9 to 10 GPM

## Dimensional Data

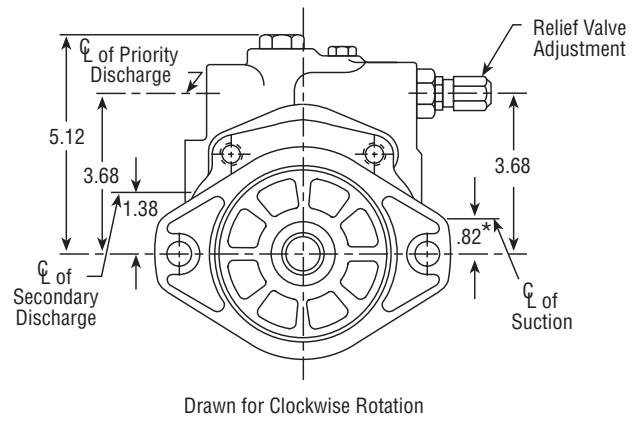
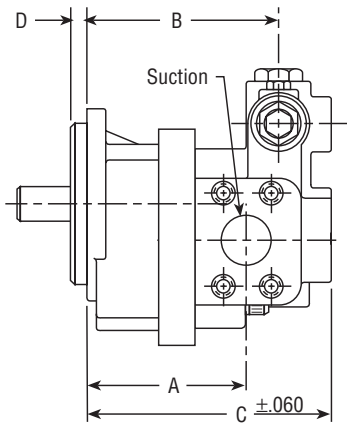
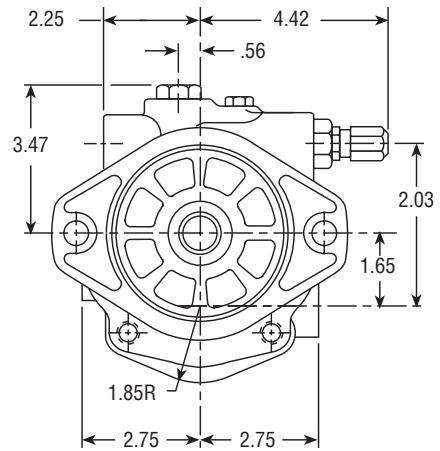
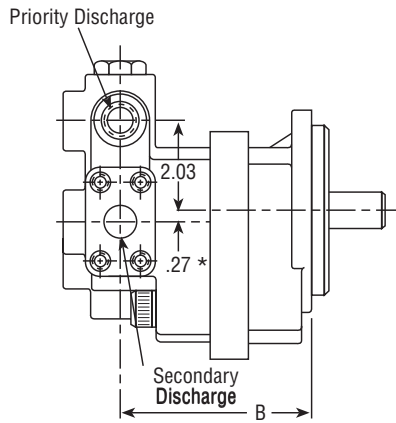

\* These dimensions locate ℄ of bolt pattern only.





Series CP16

Description . . . . . Clutch Pumps  
 Flow Range . . . . . To 38 GPM  
 Displacements . . . . . To 3.904 C.I.R.  
 Maximum Pressure to . . . . . 3000 PSI  
 Maximum Speed to . . . . . 3600 RPM  
 Rotation . . . . . A or C  
 Bearings . . . . . Journal  
 Construction . . . . . Cast Iron Gear Plates with Aluminum Flange and Cover Plate

## Performance Data

PUMP SIZES	DISPLACEMENT/REVOLUTION (Theoretical)					MAXIMUM PRESSURE						MAXIMUM SPEED RPM		
	US Gallons	Cubic Inches	Liters	Cubic Centimeters	Imperial Gallons	'V' BELT DRIVE								
						Clutch #1		Clutch #2		Clutch #3		FLAT RIBBED Drive		
						PSI	BAR	PSI	BAR	PSI	BAR	PSI	BAR	
P16 - 45	.0038	.878	.0144	14.39	.0031	3000	207	3000	207	3000	207	3000	207	3600
P16 - 65	.0055	1.270	.0208	20.83	.0045	3000	207	3000	207	3000	207	3000	207	3600
P16 - 85	.0072	1.663	.0273	27.27	.0060	2800	193	3000	207	3000	207	3000	207	3400
P16 - 100	.0085	1.964	.0321	32.21	.0070	2400	165	3000	207	3000	207	3000	207	3300
P16 - 115	.0097	2.241	.0367	36.75	.0080	2000	138	2900	200	3000	207	2900	200	3100
P16 - 150	.0127	2.934	.0481	48.11	.0105	1500	103	2600	179	3000	207	2600	179	2800
P16 - 180	.0152	3.511	.0575	57.57	.0125	1200	83	2100	145	2200	152	2100	145	2500
P16 - 200	.0169	3.904	.0639	64.02	.0140	1100	76	1900	131	2000	138	1900	131	2200

All data based on SAE 10W oil at 150°F.  
 Available with Viton Seals for use with phosphate ester base fluids.

## Torque Ratings

Clutch Option	Rating
Clutch # 1	75 ft/lbs.
Clutch # 2	125 ft/lbs.
Clutch # 3	200 ft/lbs.

## How To Order

'A' denotes counterclockwise rotation  
 'C' denotes clockwise rotation  
 When viewed from drive shaft end

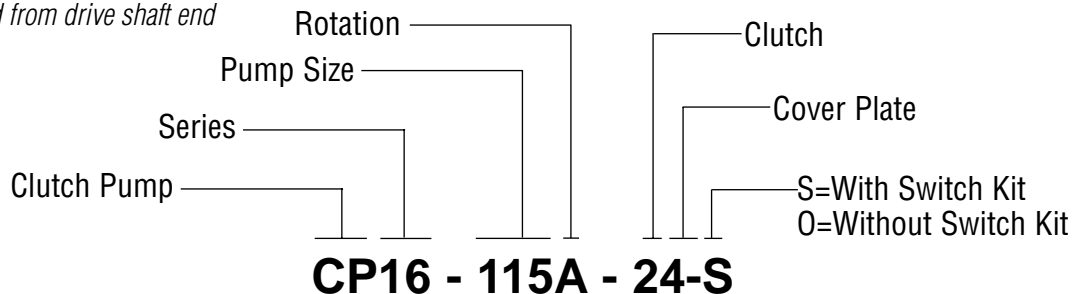

Note: Add prefix 'V' to pump model number (VCP16-) when ordering pumps with Viton Seals for use with phosphate ester base fluids.

Cover Plates Available

<p><b>2</b></p>	<p><b>Rear Ported NPTF</b></p>	<p><b>7</b></p>	<p><b>Rear Ported BSPT</b></p>	
		<p><b>3</b></p>		<p><b>Side Ported SAE 4-Bolt</b></p>
		<p>SAE 4-Bolt NPT Connectors Are Available. See Accessory Section</p>		
<p><b>4</b></p>	<p><b>Rear Ported NPTF</b></p>	<p><b>8</b></p>	<p><b>Side Ported BSPT</b></p>	
		<p><b>5</b></p>		<p><b>Side Ported Straight Thread</b></p>
		<p><b>6</b></p>		<p><b>Rear Ported Straight Thread</b></p>
<p>* These dimensions locate <math>\bar{C}</math> of bolt pattern only</p>				

Dimensional Data

## Dimensional Data

### Mounting Dimensions

PUMP SIZES	WITH CLUTCH #1										WITH CLUTCH #2					
	A		B		C		D		E		C		D		E	
	IN	MM	IN	MM	IN	MM	IN	MM	IN	MM	IN	MM	IN	MM	IN	MM
P16-45	2.53	64.3	3.54	89.9	2.41	61.2	3.96	100.6	6.12	155.5	2.38	60.5	4.07	103.4	6.71	170.4
P16-65	2.74	69.6	3.75	95.3	2.41	61.2	3.96	100.6	6.12	155.5	2.38	60.5	4.07	103.4	6.71	170.4
P16-85	2.96	75.2	3.97	100.8	2.41	61.2	3.96	100.6	6.12	155.5	2.38	60.5	4.07	103.4	6.71	170.4
P16-100	3.12	79.3	4.13	104.9	2.41	61.2	3.96	100.6	6.12	155.5	2.38	60.5	4.07	103.4	6.71	170.4
P16-115	3.28	83.3	4.29	109.0	2.41	61.2	3.96	100.6	6.12	155.5	2.38	60.5	4.07	103.4	6.71	170.4
P16-150	3.65	92.7	4.66	118.4	2.41	61.2	3.96	100.6	6.12	155.5	2.38	60.5	4.07	103.4	6.71	170.4
P16-180	3.97	100.8	4.98	126.5	2.41	61.2	3.96	100.6	6.12	155.5	2.38	60.5	4.07	103.4	6.71	170.4
P16-200	4.18	106.2	5.19	131.8	2.41	61.2	3.96	100.6	6.12	155.5	2.38	60.5	4.07	103.4	6.71	170.4

### Mounting Dimensions

PUMP SIZES	With Clutch #A									Shipping Weights (Approximate)								
	A		B		C		D		E		Clutch #1		Clutch #2		Clutch #3		Clutch #4	
	IN	MM	IN	MM	IN	MM	IN	MM	IN	MM	Lbs.	Kgs.	Lbs.	Kgs.	Lbs.	Kgs.	Lbs.	Kgs.
P16-45	2.53	64.3	3.54	89.9	3.05	77.5	4.07	103.4	5.75	146.0	18.5	8.4	22.5	10.2	28.6	13.0	22.5	10.2
P16-65	2.74	69.6	3.75	95.3	3.05	77.5	4.07	103.4	5.75	146.0	19.5	8.8	23.5	10.7	29.6	13.4	23.5	10.7
P16-85	2.96	75.2	3.97	100.8	3.05	77.5	4.07	103.4	5.75	146.0	20.5	9.3	24.5	11.1	30.6	13.9	24.5	11.1
P16-100	3.12	79.3	4.13	104.9	3.05	77.5	4.07	103.4	5.75	146.0	21.5	9.8	25.5	11.6	31.6	14.3	25.5	11.6
P16-115	3.28	83.3	4.29	109.0	3.05	77.5	4.07	103.4	5.75	146.0	22.5	10.2	26.5	12.0	32.6	14.8	26.5	12.0
P16-150	3.65	92.7	4.66	118.4	3.05	77.5	4.07	103.4	5.75	146.0	23.5	10.7	27.5	12.5	33.6	15.2	27.5	12.5
P16-180	3.97	100.8	4.98	126.5	3.05	77.5	4.07	103.4	5.75	146.0	25.5	11.6	29.5	13.4	35.6	16.1	29.5	13.4
P16-200	4.18	106.2	5.19	131.8	3.05	77.5	4.07	103.4	5.75	146.0	26.5	12.0	30.5	13.8	36.6	16.6	30.5	13.8

### Clutch No.3 Direct Drive

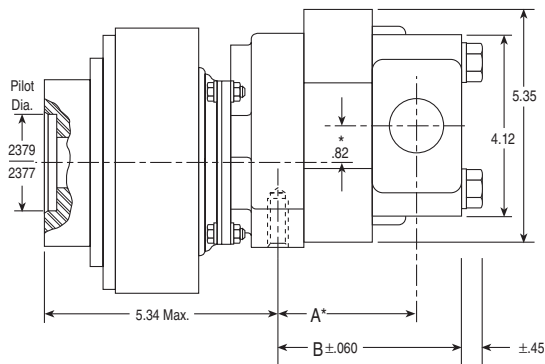
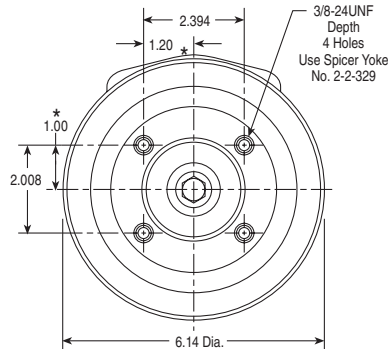

\*These dimensions locate  $\text{C}$  of bolt pattern only.

## Operating Notes

1. Detailed installation and operating instructions are included in each clutch-pump package. Consult those instructions before installation and/or operation.

**2. Clutch Data:**

- Clutch No. 1 – 12 V.D.C.; 4.26 amps;  
2.82 ohms @ 20°C; 75 Lb. Ft.
- Clutch No. 2 – 12 V.D.C.; 4.36 amps;  
2.75 ohms @ 20°C; 125 Lb. Ft.
- Clutch No. 1 – 12 V.D.C.; 4.58 amps;  
2.62 ohms @ 20°C; 200 Lb. Ft.

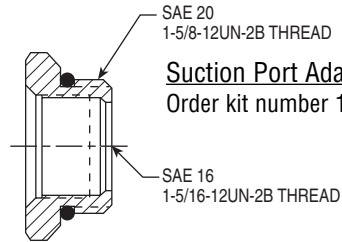

Suction Port Adapter For No.5 Body.  
Order kit number 15369

- 3. Burnishing:** If full rated torque (or system pressure) is required at start-up, burnishing or cycling of the clutch will be necessary. Burnishing of the clutch can be accomplished by running the engine between 2500 and 3000 RPM and cycling the clutch on and off against the system relief valve. The relief valve should be set at 75% of the maximum pressure rating as shown in the chart on the front page of this brochure. The clutch should be cycled 50 times at a rate of 10 to 15 cycles per minute.
- 4. Voltage:** The torque capability of the clutch varies with the actual voltage measured at the clutch. Do not operate at less than 11.5 volts.
- 5. For maximum clutch life:** #1 & #2 should be mounted to run in 'C' rotation. #3 should be mounted to run in 'A' rotation, (looking at the front of the clutch).

**Electric Clutch Switch: Order Kit No. 33520**



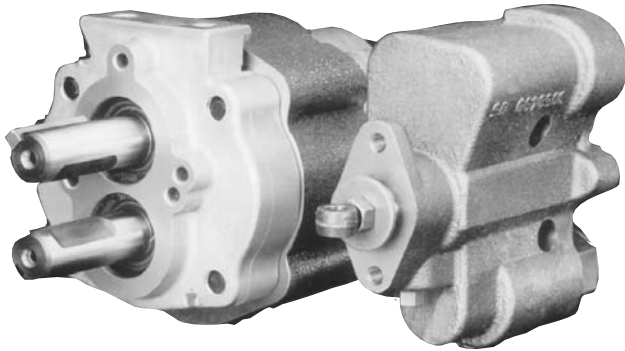

Series DP16

Description . . . . . Dump Pumps  
 Flow Range . . . . . To 38 GPM  
 Displacements . . . . . To 3.511 C.I.R.  
 Maximum Pressure to . . . . . 3000 PSI  
 Maximum Speed to . . . . . 2500 RPM  
 Rotation . . . . . A or C  
 Bearings . . . . . Journal  
 Construction . . . . . Aluminum Flange and Cover  
   Cast Iron Gear and Valve Housing

## Performance Data

PUMP SIZES	DISPLACEMENT/REVOLUTION (Theoretical)					MAXIMUM PRESSURE		MAXIMUM SPEED
	<i>US Gallons</i>	<i>Cubic Inches</i>	<i>Liters</i>	<i>Cubic Centimeters</i>	<i>Imperial Gallons</i>	<i>PSI</i>	<i>BAR</i>	<i>RPM</i>
DP16-45	.0038	.878	.0144	14.388	.003	3000	207	2500
DP16-65	.0055	1.270	.0208	20.812	.005	3000	207	2500
DP16-85	.0072	1.663	.0273	27.252	.006	3000	207	2500
DP16-100	.0085	1.964	.0321	32.184	.007	3000	207	2500
DP16-115	.0097	2.241	.0367	36.723	.008	3000	207	2500
DP16-150	.0127	2.934	.0481	48.080	.011	3000	207	2500
DP16-180	.0152	3.511	.0575	57.535	.013	3000	207	2500

All data based on SAE 10W oil at 150°F.

## How To Order

'A' denotes counterclockwise rotation  
 'C' denotes clockwise rotation  
 When viewed from drive shaft end

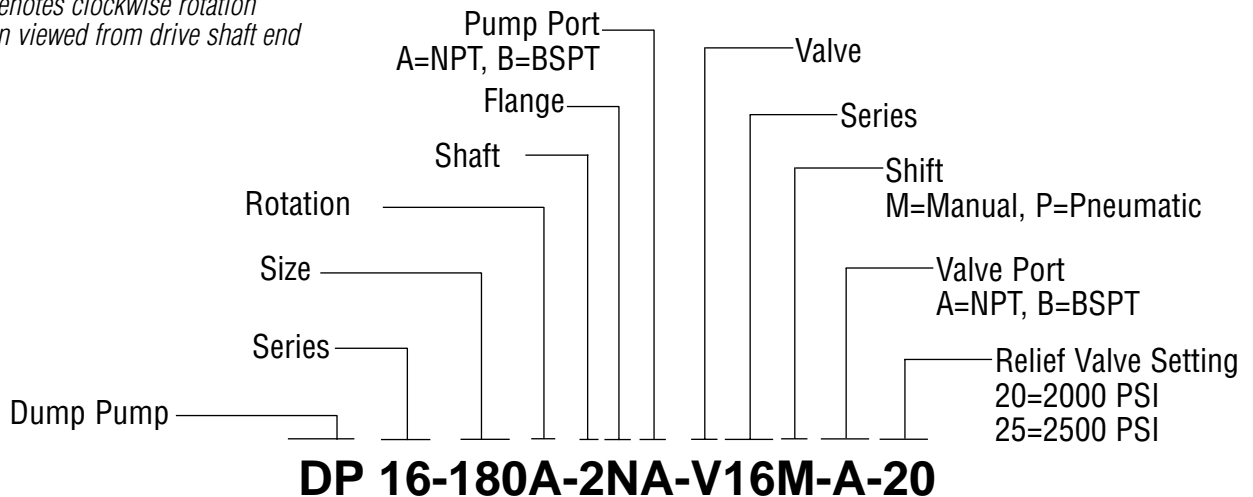

## Shafts Available

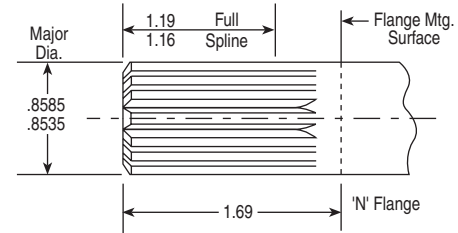
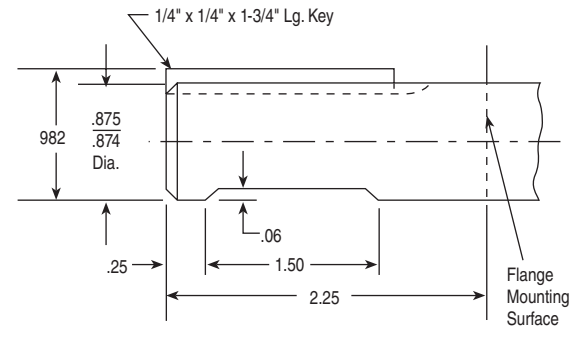
<p><b>2</b> <b>7/8" Dia. 13 Tooth Spline Flat Root Side Fit</b>                  Torque Limit 184 Lbs. Ft.                  Available with 'N' &amp; 'S' Flanges Only</p>  <p><b>Spline Data</b>                  Diametral Pitch ..... 16/32                  Pressure Angle ..... 30°                  No. Of Teeth ..... 13                  Minor Dia. .... .722-.733</p>	<p><b>5</b> <b>7/8" Straight Shaft</b>                  Torque Limit 184 Lbs. Ft.                  Available with 'F' Flanges Only</p> 
--	---

## Flanges Available with Manual Valve Operation

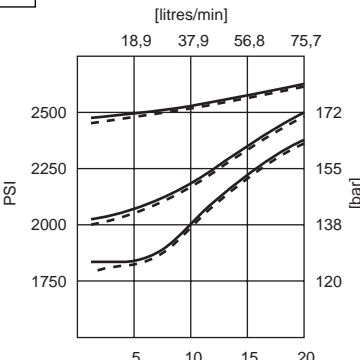
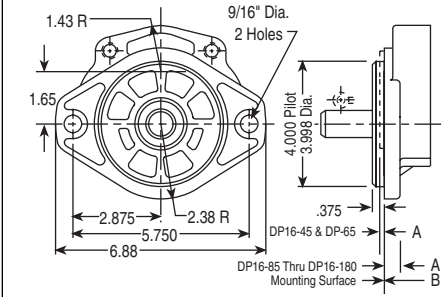
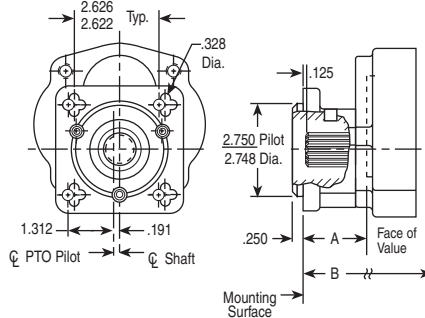
<p><b>F</b> <b>Pad Mount</b></p> 	<p><b>N</b> <b>SAE 'B' 2-Bolt</b></p> 	<p><b>S</b> <b>P.T.O. Direct Mount</b></p> 
---	--	---

## Flanges Available with Air Valve Operation

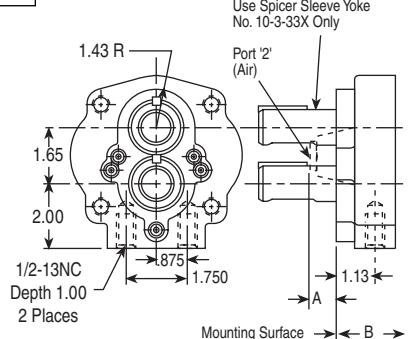
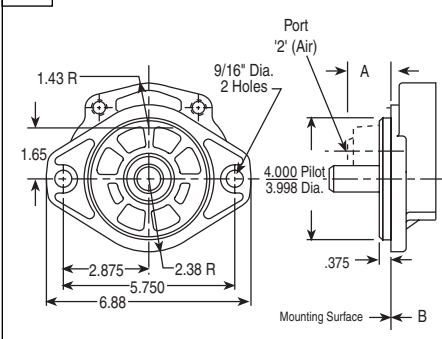
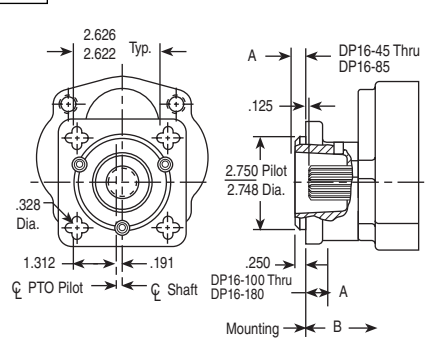
<p><b>F</b> <b>Pad Mount</b></p> <p>Use Spicer Sleeve Yoke No. 10-3-33X Only</p> 	<p><b>N</b> <b>SAE 'B' 2-Bolt</b></p> 	<p><b>S</b> <b>P.T.O. Direct Mount</b></p> 
--	--	--

## Dimensional Data for Pump with Manual Valve

### Mounting Dimensions

MOTOR SIZES	FLANGE TYPE												SHIPPING WEIGHTS (Approx.)	
	F				N				S					
	A		B		A		B		A		B		lbs.	kgs.
	IN	MM	IN	MM	IN	MM	IN	MM	IN	MM	IN	MM		
DP16-45	.07	1.78	4.67	118.7	.32	8.13	4.42	112.3	1.50	38.10	6.23	158.3	20.5	9.2
DP16-65	.14	3.56	4.88	124.0	.11	2.79	4.63	117.6	1.71	43.43	6.44	163.6	20.5	9.2
DP16-85	.36	9.15	5.10	129.5	.11	2.79	4.85	123.2	1.93	49.02	6.66	169.2	20.5	9.2
DP16-100	.52	13.21	5.26	133.7	.27	6.86	5.01	127.3	2.09	53.09	6.82	173.3	21.5	9.7
DP16-115	.68	17.28	5.42	137.7	.43	10.92	5.17	131.3	2.25	57.15	6.98	177.3	21.5	9.7
DP16-150	1.05	26.68	5.79	147.1	.80	20.32	5.54	140.7	2.62	66.55	7.35	186.7	21.5	9.7
DP16-180	1.37	34.81	6.11	155.3	1.12	28.45	5.86	148.8	2.94	74.68	7.69	195.3	22.5	10.1

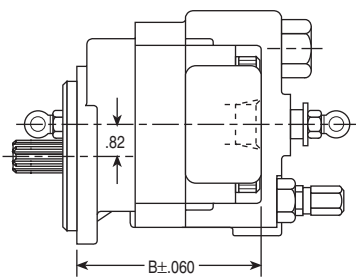
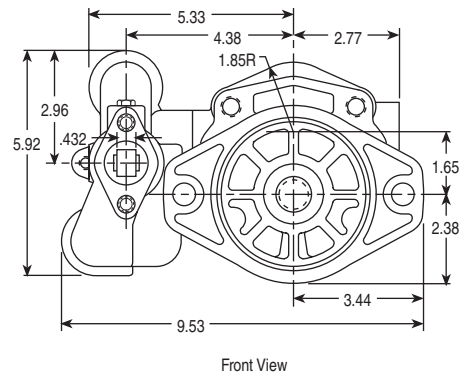
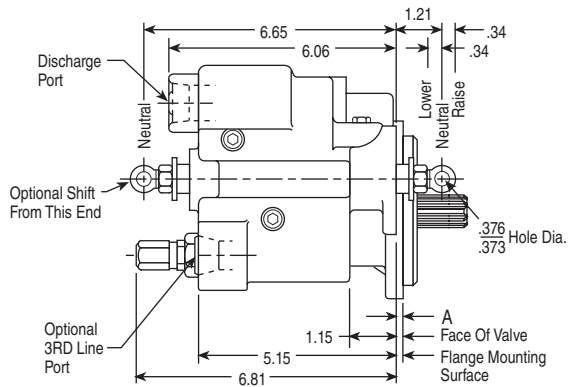

All Views Drawn With 'N' Flange And For Clockwise Rotation

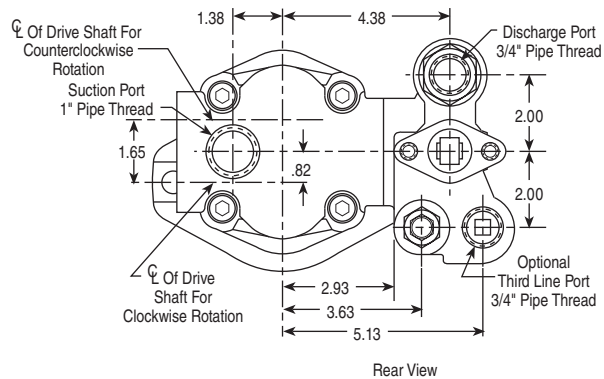

\* These dimensions locate  $\text{C}$  of bolt pattern only

## Dimensional Data for Pump with Air Valve

## Mounting Dimensions

MOTOR SIZES	FLANGE TYPE												SHIPPING WEIGHTS (Approx.)	
	F				N				S					
	A		B		A		B		A		B			
	IN	MM	IN	MM	IN	MM	IN	MM	IN	MM	IN	MM		
DP16-45	2.01	51.07	4.67	118.7	2.26	57.53	4.42	112.3	.44	11.18	6.23	158.3	20.5	9.2
DP16-65	1.80	45.74	4.88	124.0	2.05	52.09	4.63	117.7	.23	5.84	6.44	163.6	20.5	9.2
DP16-85	1.58	40.15	5.10	129.6	1.83	46.50	4.85	123.2	.01	.25	6.66	169.2	20.5	9.2
DP16-100	1.42	36.08	5.26	133.7	1.67	42.43	5.01	127.3	.15	3.81	6.82	173.3	21.5	9.7
DP16-115	1.26	32.02	5.42	137.7	1.51	38.37	5.17	131.4	.31	7.88	6.98	177.6	21.5	9.7
DP16-150	.89	22.61	5.79	147.1	1.14	28.97	5.54	140.8	.68	17.28	7.35	186.8	21.5	9.7
DP16-180	.57	14.48	6.11	155.3	.82	20.84	5.86	148.9	1.00	25.41	7.69	195.4	22.5	10.1

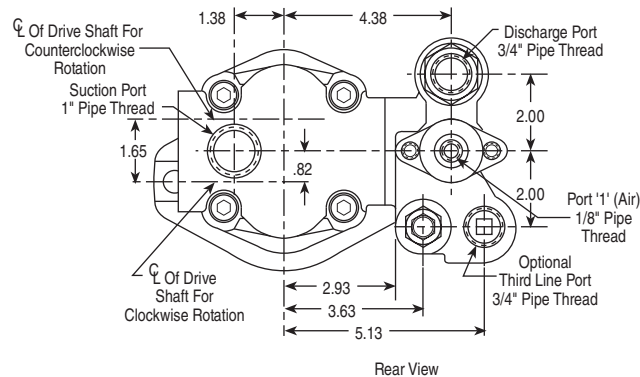
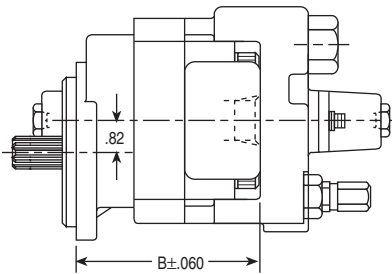
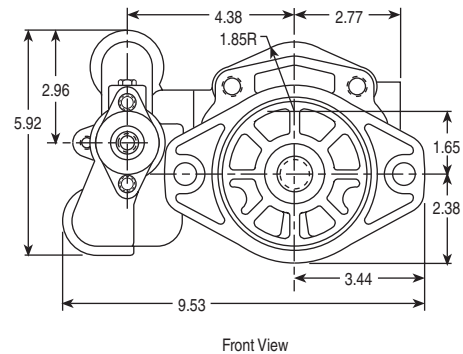
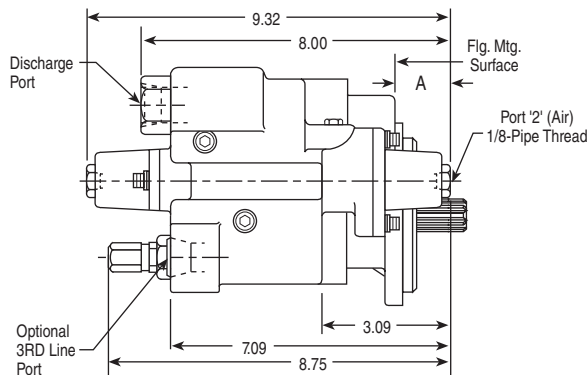

All Views Drawn With 'N' Flange And  
For Clockwise Rotation

\* These dimensions locate  $\text{C}$  of bolt pattern only

## NOTES:

## 1—Two-Line Operation:

As shipped, pumps are assembled for two-line operation, i.e., one suction line from the tank, one pressure line to the cylinder. The two-line system is recommended for intermittent operation only.

## 2—Three-Line Operation:

Uses one suction line from the tank, one return line to the tank, and one pressure line to the cylinder. Use of a filter in the return line requires a check valve between the pump and filter to prevent filter backwash. The three-line system is recommended for continuous operation applications.

3—A minimum of 60 PSI air pressure is required to shift the spool full travel to either raise or lower operating position. Pressure at port "1" (air) moves the spool to raise position. Pressure at port "2" (air) moves the spool to lower position. When vented to atmosphere, ports "1" and "2" allow spring return of the spool to neutral from either raise or lower position.

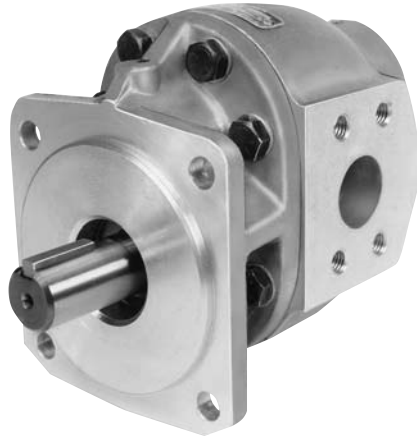

Series 20

Description . . . . . Gear Pump  
 Flow Range . . . . . To 98 GPM  
 Displacements . . . . . To 9.10 C.I.R.  
 Maximum Pressure to . . . . . 2500 PSI  
 Maximum Speed to . . . . . 2500 RPM  
 Rotation . . . . . A or C  
 Bearing . . . . . Journal  
 Construction. . . . . Aluminum or Cast Iron\*

## Performance Data

PUMP SIZES	DISPLACEMENT/REVOLUTION (Theoretical)					MAXIMUM PRESSURE		MAXIMUM SPEED
	US Gallons	Cubic Inches	Liters	Cubic Centimeters	Imperial Gallons	PSI	BAR	RPM
	20100	.0087	2.01	.0330	32.938	.0072	2500	172
20150	.0131	3.02	.0496	49.498	.0108	2500	172	2500
20200	.0175	4.04	.0662	66.204	.0146	2500	172	2500
20250	.0219	5.06	.0829	82.919	.0182	2500	172	2500
20300	.0262	6.05	.0992	99.142	.0218	2500 <sup>(1)</sup>	172	2500
20350	.0306	7.07	.1158	115.857	.0255	2500 <sup>(2)</sup>	172	2500
20400	.0350	8.08	.1325	132.408	.0292	2500	172	2500
20450	.0394	9.10	.1491	149.123	.0328	2500	172	2500

Notes: (1) 2100 PSI maximum due to torque limitations of No. 4 shaft. (2) 1800 PSI maximum due to torque limitations of No. 4 shaft  
 All data based on SAE 10W oil at 150°F. Available with Viton Seals for use with phosphate ester base fluids.  
 \*Some models and sizes are available for pressure up to 3500 PSI. Cast-iron not available on all models. Consult factory for availability.

## How To Order

'A' denotes counterclockwise rotation  
 'C' denotes clockwise rotation  
 When viewed from drive shaft end

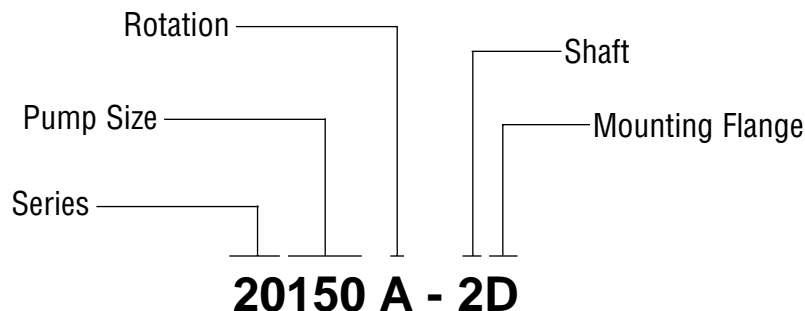

Note: Add prefix 'V' to pump model number (V20-) when ordering pumps with Viton Seals.  
 Add 'FP' to pump model number (FP20- or VFP20-) when ordering pumps with cast iron construction.

## Shafts Available

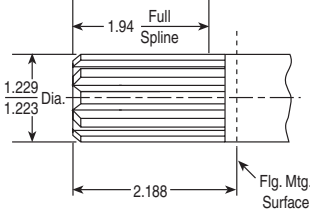
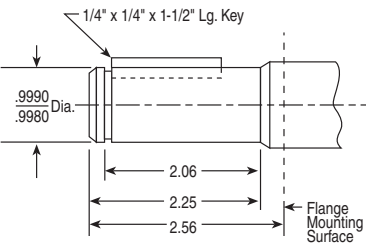
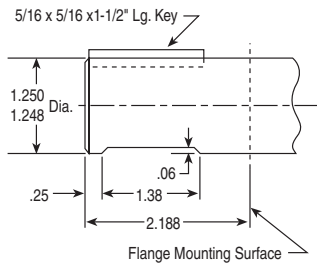
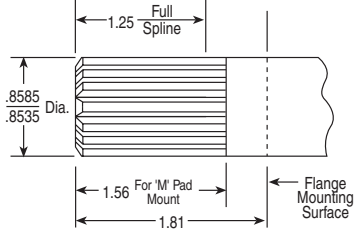
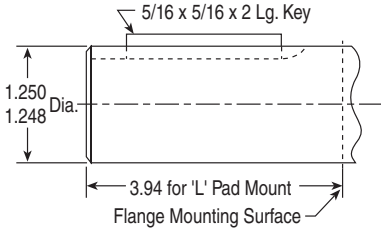
<p><b>1 SAE 'C' 1-1/4" 14 Tooth Spline</b> Torque limit 655 Lbs. Ft. Available on all sizes</p>  <p>Spline Data Diametral Pitch ..... 12/24 Pressure Angle ..... 30° No. Of Teeth ..... 14 Minor Dia. .... 1.062-1.050</p>	<p><b>2 1" Dia. Straight Shaft</b> Torque limit 341 Lbs. Ft. Available on 20100 thru 20350 only</p> 	<p><b>3 SAE 'C' 1-1/4" 14 Straight Shaft</b> Torque limit 655 Lbs. Ft. Available on all sizes.</p> 
<p><b>4 7/8" Dia. 13 Tooth Spline Flat Root Side Fit</b> Torque limit 184 Lbs. Ft. Available on 20100 thru 20350 only</p>  <p>Spline Data Diametral Pitch ..... 16/32 Pressure Angle ..... 30° No. Of Teeth ..... 13 Minor Dia. .... .733-.732</p>	<p><b>5 1-1/4" Straight Shaft</b> Torque limit 655 Lbs. Ft. Available on all sizes</p> 	

## Mounting Flanges Available

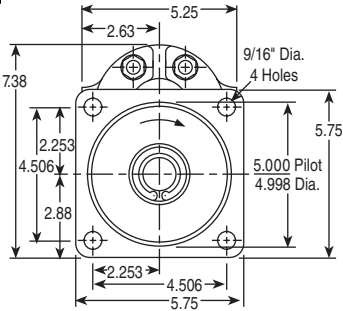
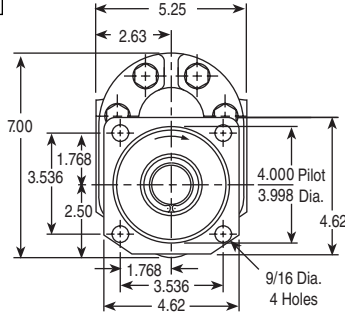
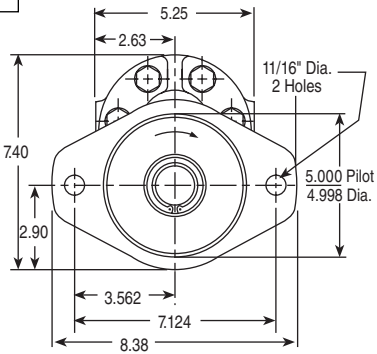
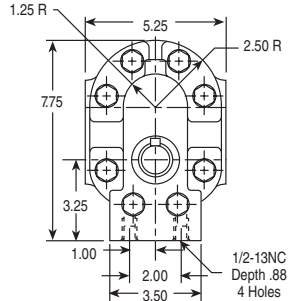
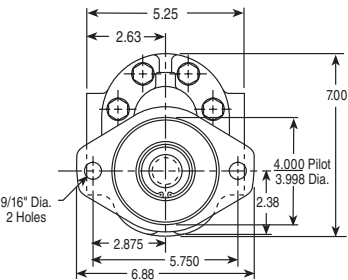
<p><b>D SAE 'C' 4-Bolt</b></p> 	<p><b>E SAE 'B' 4-Bolt</b></p> 	<p><b>F SAE 'C' 2-Bolt</b></p> 
<p><b>M 'M' Pad Mount</b></p> 	<p><b>N SAE 'B' 2-Bolt</b></p> 	

## Dimensional Data

### Mounting Dimensions

PUMP SIZE	For B & C 4-Bolt Flg. & C 2-Bolt Flg.		SAE 4-Bolt Connector Ports				Shipping Weights	
	A	B	Inlet		Outlet		lbs.	kgs.
			Conn. Sz.	Hole Dia.	Conn. Sz.	Hole Dia.		
20150	4.12	6.61	1-1/4"	1.19	1"	.937	19	8.62
20200	4.12	6.61	"	"	"	"	20	9.07
20250	4.12	6.61	1-1/2"	1.50	1-1/4"	1.19	21	9.53
20300	4.12	6.90	"	"	"	"	22	9.98
20350	4.35	7.18	"	"	"	"	23	10.4
20400	4.35	7.47	2"	2.00	"	1.37	24	10.9
20450	4.66	7.75	"	"	"	"	25	11.3

### SAE 4-Bolt Connector Ports

Size	C	D	E	F	G
1"	.51	1.031	1.03	2.062	3/8-16NC
1-1/4"	.59	1.188	1.15	2.313	7/16-14NC
1-1/2"	.70	1.406	1.37	2.750	1/2-13NC
2"	.84	1.688	1.53	3.062	1/2-13NC

SAE 4-Bolt NPT Connectors are available. See Accessory Section

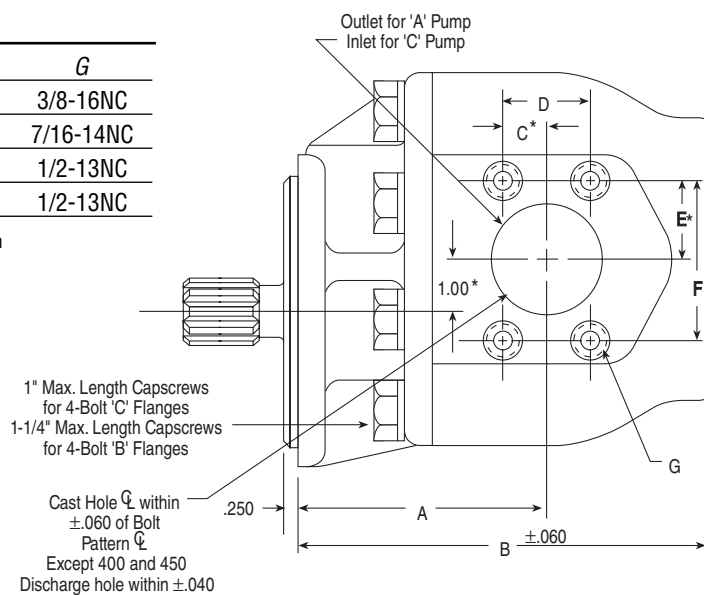

\* These dimensions locate  $\varnothing$  of bolt pattern only.

Commercial Intertech  
Cylinders, Pumps & Motors / Valves / Commercial  
Intertech Cylinders, Pumps & Motors / Custom Hoists / LHA  
Accessories / Cylinders / Prince Cylinders & Pumps / Chief  
Cylinders / Perfection Pumps / White Motors / Gresen®  
Cylinders, Pumps, Motors & Valves / Commercial Intertech  
Cylinders, Pumps & Motors / Custom Hoists / LHA Accessories  
Cylinders / Prince Cylinders & Pumps / Chief Cylinders  
Perfection Pumps / White Motors / Gresen® Cylinders, Pumps,  
Motors & Valves / Commercial Intertech Cylinders, Pumps &  
Motors / Custom Hoists / LHA Accessories / Cylinders / Prince  
Cylinders & Pumps / Chief Cylinders / Perfection Pumps / White  
Motors / Gresen® Cylinders, Pumps, Motors & Valves /  
Commercial Intertech Cylinders, Pumps & Motors / Custom  
Hoists / LHA Accessories / Cylinders / Prince Cylinders &  
Pumps / Chief Cylinders / Perfection Pumps / White Motors /  
Gresen® Cylinders, Pumps, Motors & Valves / Commercial  
Intertech Cylinders, Pumps & Motors / Custom Hoists / LHA  
Accessories / Cylinders / Prince Cylinders & Pumps / Chief  
Cylinders / Perfection Pumps / White Motors / Gresen®  
Cylinders, Pumps, Motors & Valves / Commercial Intertech  
Cylinders, Pumps & Motors / Custom Hoists / LHA Accessories  
Cylinders / Prince Cylinders & Pumps / Chief Cylinders /  
Perfection Pumps / White Motors / Gresen® Cylinders, Pumps,  
Motors & Valves / Commercial Intertech Cylinders, Pumps &  
Motors / Custom Hoists / LHA Accessories / Cylinders / Prince  
Cylinders & Pumps / Chief Cylinders / Perfection Pumps / White  
Motors / Gresen® Cylinders, Pumps, Motors & Valves /  
Commercial Intertech Cylinders, Pumps & Motors / Custom  
Hoists / LHA Accessories / Cylinders / Prince Cylinders &  
Pumps / Chief Cylinders / Perfection Pumps / White Motors /  
Gresen® Cylinders, Pumps, Motors & Valves / Commercial  
Intertech Cylinders, Pumps & Motors / Custom Hoists / LHA  
Accessories / Cylinders / Prince Cylinders & Pumps / Chief  
Cylinders / Perfection Pumps / White Motors / Gresen®  
Cylinders, Pumps, Motors & Valves / Commercial Intertech  
Cylinders, Pumps & Motors / Custom Hoists / LHA Accessories  
Cylinders / Prince Cylinders & Pumps / Chief Cylinders /





Series R20

Description . . . . . Gear Pump  
 Flow Range . . . . . To 98 GPM  
 Displacements . . . . . To 9.10 C.I.R.  
 Maximum Pressure to . . . . . 2500 PSI  
 Maximum Speed to . . . . . 2500 RPM  
 Rotation . . . . . Reversible  
 Bearing . . . . . Journal  
 Construction . . . . . Aluminum or Cast Iron\*

## Performance Data

PUMP SIZES	DISPLACEMENT/REVOLUTION (Theoretical)					MAXIMUM PRESSURE		MAXIMUM SPEED
	US Gallons	Cubic Inches	Liters	Cubic Centimeters	Imperial Gallons	PSI	BAR	RPM
	20100	.0087	2.01	.0330	32.938	.0072	2500	172
20150	.0131	3.02	.0496	49.498	.0108	2500	172	2500
20200	.0175	4.04	.0662	66.204	.0146	2500	172	2500
20250	.0219	5.06	.0829	82.919	.0182	2500	172	2500
20300	.0262	6.05	.0992	99.142	.0218	2500 <sup>(1)</sup>	172	2500
20350	.0306	7.07	.1158	115.857	.0255	2500 <sup>(2)</sup>	172	2500
20400	.0350	8.08	.1325	132.408	.0292	2500	172	2500
20450	.0394	9.10	.1491	149.123	.0328	2500	172	2500

Notes: (1) 2100 PSI maximum due to torque limitations of No. 4 shaft. (2) 1800 PSI maximum due to torque limitations of No. 4 shaft  
 All data based on SAE 10W oil at 150°F. Available with Viton Seals for use with phosphate ester base fluids.  
 \*Some models and sizes are available for pressure up to 3500 PSI. Cast-iron not available on all models. Consult factory for availability.

## How To Order

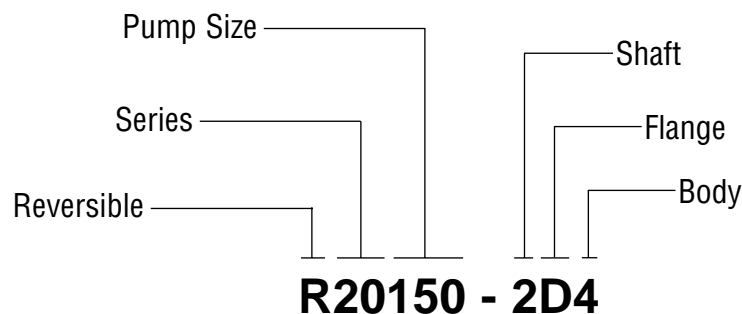

Note: Add prefix 'V' to pump model number (VR20-) when ordering with Viton Seals for use with phosphate ester based fluids.

## Shafts Available

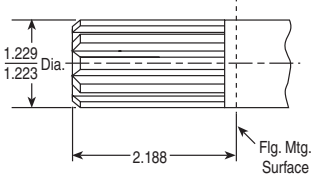
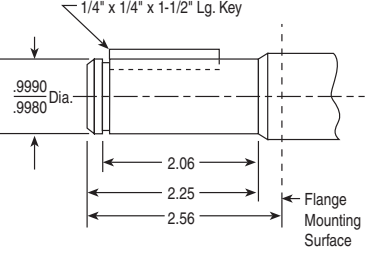
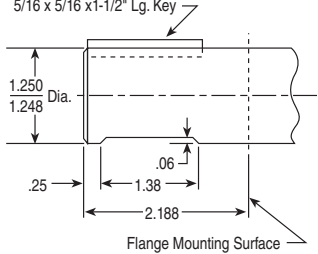
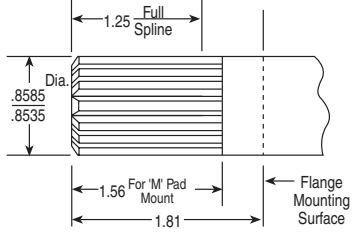
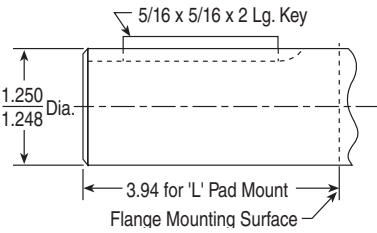
<p><b>1</b> <b>SAE 'C' 1-1/4" 14 Tooth Spline</b> Torque limit 655 Lbs. Ft. Available on all sizes</p>  <p>Spline Data Diametral Pitch ..... 12/24 Pressure Angle ..... 30° No. Of Teeth ..... 14 Minor Dia. .... 1.062-1.050</p>	<p><b>2</b> <b>1" Dia. Straight Shaft</b> Torque limit 314 Lbs. Ft. Available on 20100 thru 20250 only</p> 	<p><b>3</b> <b>SAE 'C' 1-1/4" Straight Shaft</b> Torque limit 655 Lbs. Ft. Available on all sizes</p> 
<p><b>4</b> <b>7/8" Dia. 13 Tooth Spline Flat Root Side Fit</b> Torque limit 184 Lbs. Ft. Available on 20100 thru 20350 only</p>  <p>Spline Data Diametral Pitch ..... 16/32 Pressure Angle ..... 30° No. Of Teeth ..... 13 Minor Dia. .... .733-.722</p>	<p><b>5</b> <b>1-1/4" Straight Shaft</b> Torque limit 655 Lbs. Ft. Available on all sizes</p> 	

## Flanges Available

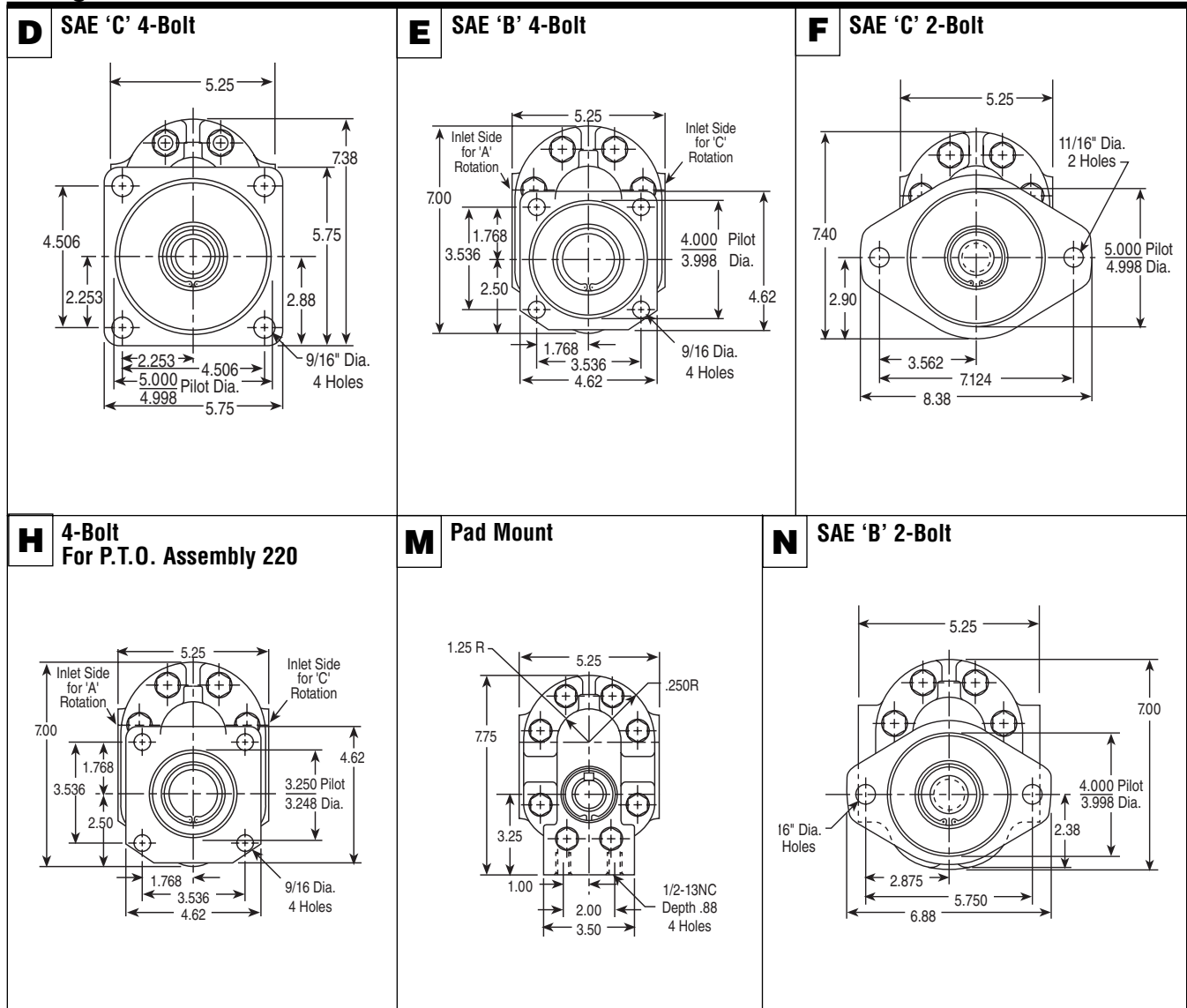

## Dimensional Data

## Mounting Dimensions

PUMP SIZE	For B & C 4-Bolt Flg. & C 2-Bolt Flg.		No. 3SAE 4-Bolt Port Both Sides		No. 4 NPT Port Both Sides	Shipping Weights	
	A	B	Conn. Sz.	Hole Dia.		lbs.	kgs.
R20150	4.12	6.61	1"	1.00	1"	19	8.62
R20200	4.12	6.61	1"	"	1-1/4"	20	9.07
R20250	4.12	6.61	1-1/4"	1.25	1-1/2"	21	9.53
R20300	4.12	6.90	1-1/4"	"	1-1/2"	22	9.98
R20350	4.35	7.18	1-1/2"	1.50	1-1/2"	23	10.4
R20400	4.35	7.47	1-1/2"	"	—	24	10.9
R20450	4.66	7.75	1-1/2"	"	—	25	11.3

## SAE 4-Bolt Connector Ports

Size	C	D	E	F	G
1"	.51	1.031	1.03	2.062	3/8-16NC
1-1/4"	.59	1.188	1.15	2.313	7/16-14NC
1-1/2"	.70	1.406	1.37	2.750	1/2-13NC

SAE 4-Bolt NPT Connectors are available. See Accessory Section

3

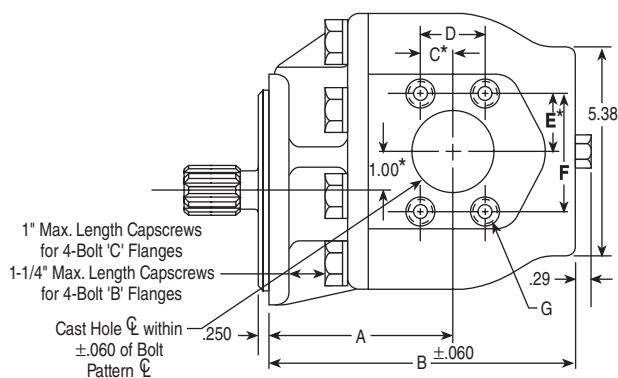

\* These dimensions locate  $\varnothing$  of bolt pattern only

4

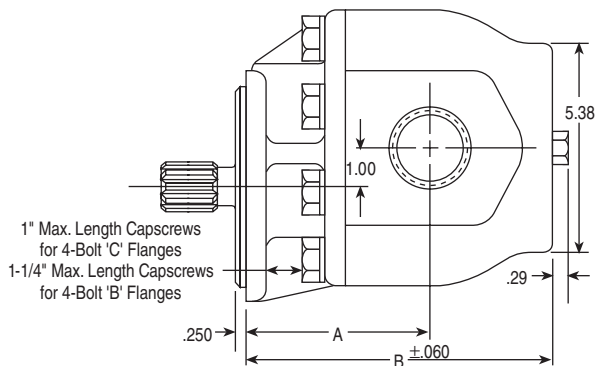



Series M20

Description . . . . . Gear Motors  
 Flow Range . . . . . To 98 GPM  
 Displacements . . . . . To 9.10 C.I.R.  
 Maximum Pressure to . . . . . 2500 PSI  
 Maximum Speed to . . . . . 2500 RPM  
 Rotation . . . . . Bi-Directional  
 Bearings . . . . . Journal  
 Construction . . . . . Aluminum

## Performance Data

MOTOR SIZES	DISPLACEMENT/REVOLUTION (Theoretical)					Lb.-In. Torque at 2500 PSI <sup>(2)</sup>		H.P. at Max. RPM Max. PSI <sup>(2)</sup>	Max. Limits		
	US Gallons	Cubic Inches	Liters	Cubic Centimeters	Imperial Gallons	Start	Run		Pressure		Speed RPM
									PSI	BAR	
20150	.0131	3.02	.0496	49.849	.011	680	1000	38	2500	172	2500
20200	.0175	4.04	.0662	66.204	.015	960	1470	50	2500	172	2500
20250	.0219	5.06	.0829	82.919	.018	1240	1800	64	2500	172	2500
20300	.0262	6.05	.0992	99.142	.022	1520	2200	74	2500	172	2500
20350	.0306	7.07	.1158	115.857	.025	1800	2500	90	2500	172	2500
20400	.0350	8.08	.1325	132.408	.029	2050	2800	105	2500	172	2500
20450	.0394	9.10	.1461	149.123	.033	2350	3350	124	2500	172	2500

\*Average values from performance curves.  
 Available with Viton Seals for use with phosphate ester base fluids. All data based on SAE 10W oil at 135°F.

## How To Order

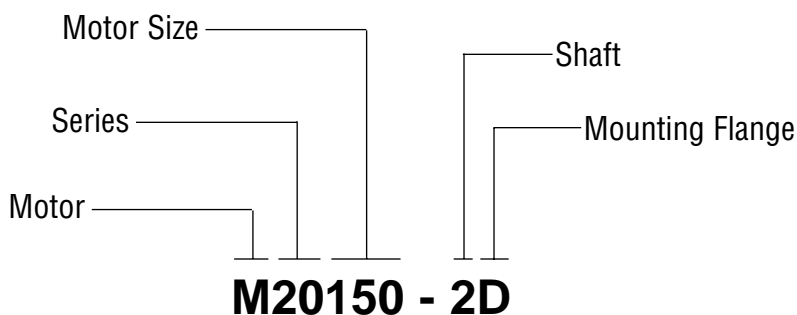

Note: Add 'V' to pump model number (MV20-) when ordering pumps with Viton Seals for use with phosphate ester base fluids.

## Shafts Available

<p><b>1 SAE 'C' 1-1/4" 14 Tooth Spline</b> Torque Limit 655 Lbs. Ft. Available on all sizes</p> <p><b>Spline Data</b> Diametral Pitch ..... 12/24 Pressure Angle ..... 30° No. Of Teeth ..... 13 Minor Dia. .... 1.062-1.055</p>	<p><b>2 1" Dia. Straight Shaft</b> Torque Limit 341 Lbs. Ft. Available on 20150 thru 20250 only 1/4" x 1/4" x 1-1/2" Lg. Key</p>	<p><b>3 SAE 'C' 1-1/4" Straight Shaft</b> Torque Limit 655 Lbs. Ft. Available on all sizes 5/16 x 5/16 x 1-1/2" Lg. Key</p>
<p><b>4 7/8" Dia. 13-Tooth Spline Flat Root Side Fit</b> Torque Limit 184 Lbs. Ft. Available on 20150 thru 20350 only</p> <p><b>Spline Data</b> Diametral Pitch ..... 16/32 Pressure Angle ..... 30° No. Of Teeth ..... 14 Minor Dia. .... .733-.732</p>	<p><b>5 1-1/4" Straight Shaft</b> Torque Limit 655 Lbs. Ft. Available on all sizes</p>	

## Mounting Flanges Available

<p><b>D SAE 'C' 4-Bolt</b></p>	<p><b>E SAE 'B' 4-Bolt</b></p>	<p><b>F SAE 'C' 2-Bolt</b></p>
<p><b>M 'M' Pad Mount</b></p>	<p><b>N SAE 'B' 2-Bolt</b></p>	

## Dimensional Data

### Mounting Dimensions

MOTOR SIZE	For 'C' 2-Bolt & 'B' & 'C' 4-Bolt Flg.		SAE 4-Bolt Conn. Port				Shipping Weights (Approx.)	
			Inlet		Outlet			
	A	B	Conn. Sz.	Hole Dia.	Conn. Sz.	Hole Dia.	lbs.	kgs.
M20150	4.12	6.61	1"	1.00	1"	1.00	19	8.62
M20200	4.12	6.61	1"	1.00	1"	1.00	20	9.07
M20250	4.12	6.61	1-1/4"	1.25	1-1/4"	1.25	21	9.53
M20300	4.12	6.90	1-1/4"	1.25	1-1/4"	1.25	22	9.98
M20350	4.35	7.18	1-1/2"	1.50	1-1/2"	1.50	23	10.4
M20400	4.35	7.47	1-1/2"	1.50	1-1/2"	1.50	24	10.9
M20450	4.66	7.75	1-1/2"	1.50	1-1/2"	1.50	25	11.3

### SAE 4-Bolt Connector Ports

Size	C	D	E	F	G
1"	.51	1.031	1.03	2.062	3/8-16NC
1-1/4"	.59	1.188	1.15	2.313	7/16-14NC
1-1/2"	.70	1.406	1.37	2.750	1/2-13NC

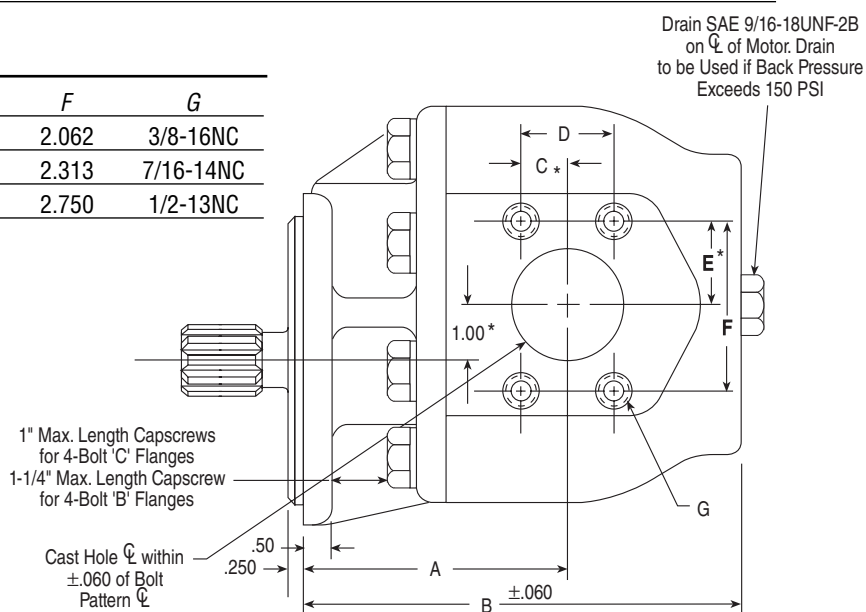

\* These dimensions locate  $\phi$  of bolt pattern only

ntertech Cylinders, Pumps & Motors / Custom Hoists / LHA  
Accessories / Cylinders / Prince Cylinders & Pumps / Chief  
Cylinders / Perfection Pumps / White Motors / Gresen®  
Cylinders, Pumps, Motors & Valves / Commercial Intertech  
Cylinders, Pumps & Motors / Custom Hoists / LHA Accessories  
Cylinders / Prince Cylinders & Pumps / Chief Cylinders  
Perfection Pumps / White Motors / Gresen® Cylinders, Pumps,  
Motors & Valves / Commercial Intertech Cylinders, Pumps &  
Motors / Custom Hoists / LHA Accessories / Cylinders / Prince  
Cylinders & Pumps / Chief Cylinders / Perfection Pumps / White  
Motors / Gresen® Cylinders, Pumps, Motors & Valves /  
Commercial Intertech Cylinders, Pumps & Motors / Custom  
Hoists / LHA Accessories / Cylinders / Prince Cylinders &  
Pumps / Chief Cylinders / Perfection Pumps / White Motors /  
Gresen® Cylinders, Pumps, Motors & Valves / Commercial  
Intertech Cylinders, Pumps & Motors / Custom Hoists / LHA  
Accessories / Cylinders / Prince Cylinders & Pumps / Chief  
Cylinders / Perfection Pumps / White Motors / Gresen®  
Cylinders, Pumps, Motors & Valves / Commercial Intertech  
Cylinders, Pumps & Motors / Custom Hoists / LHA Accessories  
Cylinders / Prince Cylinders & Pumps / Chief Cylinders /  
Perfection Pumps / White Motors / Gresen® Cylinders, Pumps,  
Motors & Valves / Commercial Intertech Cylinders, Pumps &  
Motors / Custom Hoists / LHA Accessories / Cylinders / Prince  
Cylinders & Pumps / Chief Cylinders / Perfection Pumps / White  
Motors / Gresen® Cylinders, Pumps, Motors & Valves /  
Commercial Intertech Cylinders, Pumps & Motors / Custom  
Hoists / LHA Accessories / Cylinders / Prince Cylinders &  
Pumps / Chief Cylinders / Perfection Pumps / White Motors /  
Gresen® Cylinders, Pumps, Motors & Valves / Commercial  
Intertech Cylinders, Pumps & Motors / Custom Hoists / LHA  
Accessories / Cylinders / Prince Cylinders & Pumps / Chief  
Cylinders / Perfection Pumps / White Motors / Gresen®  
Cylinders, Pumps, Motors & Valves / Commercial Intertech  
Cylinders, Pumps & Motors / Custom Hoists / LHA Accessories  
Cylinders / Prince Cylinders & Pumps / Chief Cylinders /





Series TP20

Description . . . . . Gear Pumps (Two-place)  
 Flow Range . . . . . To 98 GPM Per Section  
 Displacements . . . . . To 9.10 C.I.R. Per Section  
 Maximum Pressure to . . . . . 2500 PSI  
 Maximum Speed to . . . . . 2500 RPM  
 Rotation . . . . . A or C  
 Bearing . . . . . Journal  
 Construction . . . . . Aluminum or Cast Iron\*

## Performance Data

PUMP SIZES	DISPLACEMENT/REVOLUTION (Theoretical)					MAXIMUM PRESSURE		MAXIMUM SPEED
	US Gallons	Cubic Inches	Liters	Cubic Centimeters	Imperial Gallons	PSI	BAR	RPM
	20080	.0070	1.62	.0265	26.498	.0058	2500	172
20100	.0087	2.01	.0330	32.938	.0072	2500	172	2500
20150	.0131	3.02	.0496	49.498	.0108	2500	172	2500
20200	.0175	4.04	.0662	66.204	.0146	2500	172	2500
20250	.0219	5.06	.0829	82.919	.0182	2500	172	2500
20300	.0262	6.05	.0992	99.142	.0218	2500	172	2500
20350	.0306	7.07	.1158	115.857	.0255	2500	172	2500
20400	.0350	8.08	.1325	132.408	.0292	2500	172	2500
20450	.0394	9.10	.1491	149.123	.0328	2500	172	2500

All data based on SAE 10W oil at 150°F. Available with Viton Seals for use with phosphate ester base fluids.  
 \*Some models and sizes are available for pressure up to 3500 PSI. Cast-iron not available on all models. Consult factory for availability.

## How To Order

'A' denotes counterclockwise rotation  
 'C' denotes clockwise rotation  
 When viewed from drive shaft end

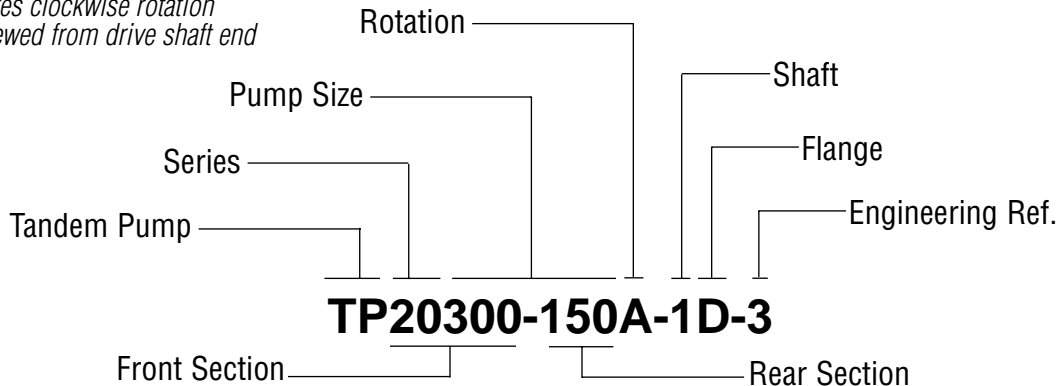

Note: Add prefix 'V' to pump model number (VTP20) when ordering pumps with Viton Seals for use with phosphate ester base fluids.  
 Add 'F' to pump model number (TFP20 or VTFP20) when ordering pumps with cast iron construction.

## Shafts Available

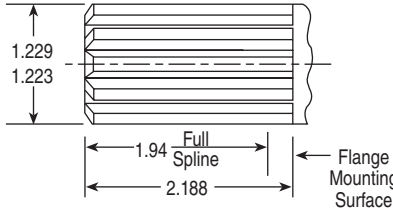
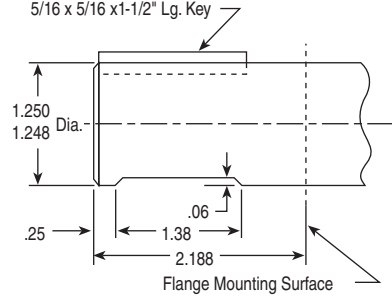
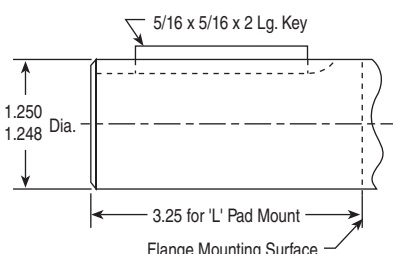
<p><b>1</b> SAE 'C' 1-1/4" 14 Tooth Torque limit 655 Lbs. Ft.</p>  <p style="text-align: right;">Flange Mounting Surface</p> <p><b>Spline Data</b>          Diametral Pitch ..... 12/24          Pressure Angle ..... 30°          No. Of Teeth ..... 14          Minor Dia. .... 1.062-1.052</p>	<p><b>3</b> SAE 'C' 1-1/4" Straight Torque limit 655 Lbs. Ft.</p>  <p style="text-align: right;">Flange Mounting Surface</p>	<p><b>5</b> 1-1/4" Straight Shaft Torque limit 655 Lbs. Ft.</p>  <p style="text-align: right;">Flange Mounting Surface</p>
--	--	---

## Mounting Flanges Available

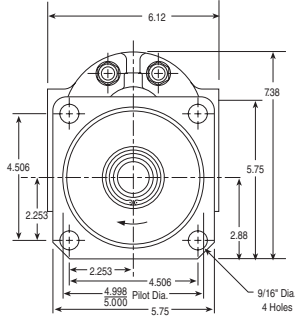
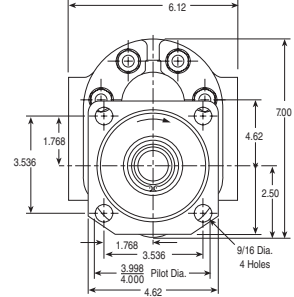
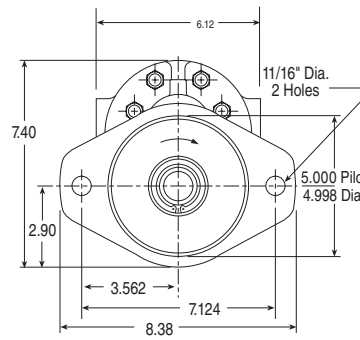
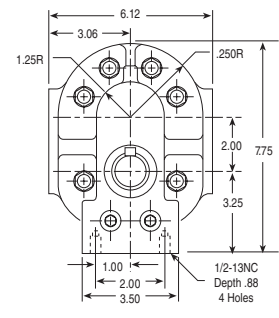
<p><b>D</b> SAE 'C' 4-Bolt</p> 	<p><b>E</b> SAE 'B' 4-Bolt</p> 
<p><b>F</b> SAE 'C' 2-Bolt</p> 	<p><b>M</b> 'M' Pad Mount</p> 

## Dimensional Data

### Mounting Dimensions

Pump Sizes	Port Sizes						Mounting Dimensions			
	Common Suction		Discharge Front		Discharge Rear					
	Hole Dia.	Conn. Size	Hole Dia.	Conn. Size	Hole Dia.	Conn. Size	A	B	C	J
TP20150-080	1.50	1 1/2	.75	3/4	.75	3/4	3.60	7.83	9.44	3.75
TP20150-100	1.50	1 1/2	.75	3/4	.75	3/4	3.60	7.93	9.56	3.75
TP20150-150	1.50	1 1/2	.75	3/4	.75	3/4	3.60	7.93	9.85	3.75
TP20200-080	1.50	1 1/2	1.00	1	.75	3/4	3.75	8.76	10.38	3.86
TP20200-100	1.50	1 1/2	1.00	1	.75	3/4	3.75	8.86	10.50	3.86
TP20200-150	2.00	2	1.00	1	.75	3/4	3.75	8.86	10.79	3.86
TP20200-200	2.00	2	1.00	1	1.00	1	3.75	9.50	12.12	3.86
TP20250-080	2.00	2	1.19	1 1/4	.75	3/4	4.00	9.05	10.67	4.00
TP20250-100	2.00	2	1.19	1 1/4	.75	3/4	4.00	9.15	10.79	4.00
TP20250-150	2.00	2	1.19	1 1/4	.75	3/4	4.00	9.15	11.07	4.00
TP20250-200	2.00	2	1.19	1 1/4	1.00	1	4.00	9.79	12.41	4.00
TP20250-250	2.00	2	1.19	1 1/4	1.25	1 1/4	4.00	10.04	12.80	4.00
TP20300-080	2.00	2	1.19	1 1/4	.75	3/4	4.14	9.32	10.95	4.14
TP20300-100	2.00	2	1.19	1 1/4	.75	3/4	4.14	9.42	11.07	4.14
TP20300-150	2.00	2	1.19	1 1/4	.75	3/4	4.14	9.42	11.34	4.14
TP20300-200	2.00	2	1.19	1 1/4	1.00	1	4.14	10.07	12.69	4.14
TP20300-250	2.00	2	1.19	1 1/4	1.25	1 1/4	4.14	10.32	13.09	4.14
TP20300-300	2.50	2 1/2	1.19	1 1/4	1.19	1 1/4	4.14	10.32	13.37	4.14
TP20350-080	2.50	2 1/2	1.19	1 1/4	.75	3/4	4.35	9.62	11.24	4.34
TP20350-100	2.50	2 1/2	1.19	1 1/4	.75	3/4	4.35	9.72	11.36	4.34
TP20350-150	2.50	2 1/2	1.19	1 1/4	.75	3/4	4.35	9.72	11.64	4.34
TP20350-200	2.50	2 1/2	1.19	1 1/4	1.00	1	4.35	10.35	12.98	4.34
TP20350-250	2.50	2 1/2	1.19	1 1/4	1.25	1 1/4	4.35	10.60	13.37	4.34
TP20350-300	2.50	2 1/2	1.19	1 1/4	1.19	1 1/4	4.35	10.60	13.66	4.34
TP20400-080	2.43	2 1/2	1.37	1 1/2	.75	3/4	4.35	9.90	11.52	4.34
TP20400-100	2.43	2 1/2	1.37	1 1/2	.75	3/4	4.35	10.00	11.64	4.34
TP20400-150	2.43	2 1/2	1.37	1 1/2	.75	3/4	4.35	10.00	11.92	4.34
TP20400-200	2.43	2 1/2	1.37	1 1/2	1.00	1	4.35	10.64	13.26	4.34
TP20400-250	2.43	2 1/2	1.37	1 1/2	1.25	1 1/4	4.35	10.89	13.66	4.34
TP20400-300	2.43	2 1/2	1.37	1 1/2	1.19	1 1/4	4.35	10.89	13.94	4.34
TP20450-080	2.43	2 1/2	1.37	1 1/2	.75	3/4	4.66	10.18	11.80	4.34
TP20450-100	2.43	2 1/2	1.37	1 1/2	.75	3/4	4.66	10.28	11.92	4.34
TP20450-150	2.43	2 1/2	1.37	1 1/2	.75	3/4	4.66	10.28	12.20	4.34
TP20450-200	2.43	2 1/2	1.37	1 1/2	1.00	1	4.66	10.92	13.54	4.34
TP20450-250	2.43	2 1/2	1.37	1 1/2	1.25	1 1/4	4.66	11.17	13.94	4.34
TP20450-300	2.43	2 1/2	1.37	1 1/2	1.19	1 1/4	4.66	11.17	14.22	4.34

### SAE 4-Bolt Connector Ports

Size	D	E	F	G	H
3/4"	.43	.875	.93	1.875	3/8-16NC
1"	.51	1.031	1.03	2.062	3/8-16NC
1-1/4"	.59	1.188	1.15	2.313	7/16-14NC
1-1/2"	.70	1.406	1.37	2.750	1/2-13NC
2"	.84	1.688	1.53	3.062	1/2-13NC
2-1/2"	1.00	2.000	1.75	3.500	1/2-13NC

SAE 4-Bolt NPT Connectors are available. See Accessory Section

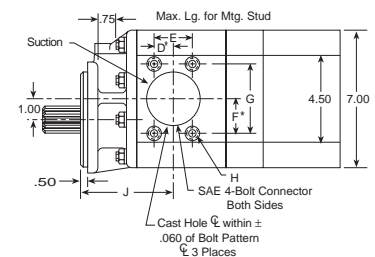
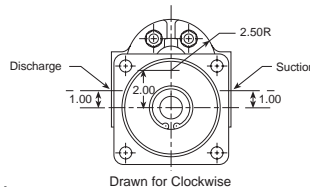
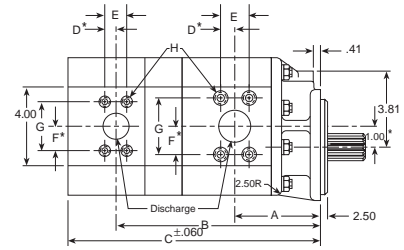
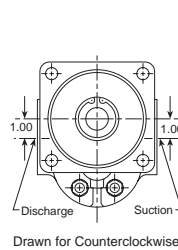

\* These dimensions locate  $\phi$  of bolt pattern only

ntertech Cylinders, Pumps & Motors / Custom Hoists / LHA  
Accessories / Cylinders / Prince Cylinders & Pumps / Chief  
Cylinders / Perfection Pumps / White Motors / Gresen®  
Cylinders, Pumps, Motors & Valves / Commercial Intertech  
Cylinders, Pumps & Motors / Custom Hoists / LHA Accessories  
Cylinders / Prince Cylinders & Pumps / Chief Cylinders  
Perfection Pumps / White Motors / Gresen® Cylinders, Pumps,  
Motors & Valves / Commercial Intertech Cylinders, Pumps &  
Motors / Custom Hoists / LHA Accessories / Cylinders / Prince  
Cylinders & Pumps / Chief Cylinders / Perfection Pumps / White  
Motors / Gresen® Cylinders, Pumps, Motors & Valves /  
Commercial Intertech Cylinders, Pumps & Motors / Custom  
Hoists / LHA Accessories / Cylinders / Prince Cylinders &  
Pumps / Chief Cylinders / Perfection Pumps / White Motors /  
Gresen® Cylinders, Pumps, Motors & Valves / Commercial  
Intertech Cylinders, Pumps & Motors / Custom Hoists / LHA  
Accessories / Cylinders / Prince Cylinders & Pumps / Chief  
Cylinders / Perfection Pumps / White Motors / Gresen®  
Cylinders, Pumps, Motors & Valves / Commercial Intertech  
Cylinders, Pumps & Motors / Custom Hoists / LHA Accessories  
Cylinders / Prince Cylinders & Pumps / Chief Cylinders /  
Perfection Pumps / White Motors / Gresen® Cylinders, Pumps,  
Motors & Valves / Commercial Intertech Cylinders, Pumps &  
Motors / Custom Hoists / LHA Accessories / Cylinders / Prince  
Cylinders & Pumps / Chief Cylinders / Perfection Pumps / White  
Motors / Gresen® Cylinders, Pumps, Motors & Valves /  
Commercial Intertech Cylinders, Pumps & Motors / Custom  
Hoists / LHA Accessories / Cylinders / Prince Cylinders &  
Pumps / Chief Cylinders / Perfection Pumps / White Motors /  
Gresen® Cylinders, Pumps, Motors & Valves / Commercial  
Intertech Cylinders, Pumps & Motors / Custom Hoists / LHA  
Accessories / Cylinders / Prince Cylinders & Pumps / Chief  
Cylinders / Perfection Pumps / White Motors / Gresen®  
Cylinders, Pumps, Motors & Valves / Commercial Intertech  
Cylinders, Pumps & Motors / Custom Hoists / LHA Accessories  
Cylinders / Prince Cylinders & Pumps / Chief Cylinders /

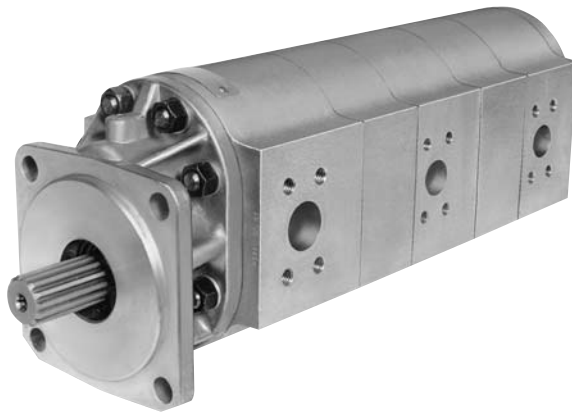

Series TP20

Description . . . . . Gear Pump (Three-place)  
 Flow Range . . . . . To 98 GPM Per Section  
 Displacements . . . . . To 9.10 C.I.R. Per Section  
 Maximum Pressure to . . . . . 2500 PSI  
 Maximum Speed to . . . . . 2500 RPM  
 Rotation . . . . . A or C  
 Bearing . . . . . Journal  
 Construction . . . . . Aluminum or Cast Iron\*

## Performance Data

PUMP SIZES	DISPLACEMENT/REVOLUTION (Theoretical)					MAXIMUM PRESSURE		MAXIMUM SPEED
	US Gallons	Cubic Inches	Liters	Cubic Centimeters	Imperial Gallons	PSI	BAR	RPM
	20100	.0087	2.01	.0330	32.938	.0072	2500	172
20150	.0131	3.02	.0496	49.498	.0108	2500	172	2500
20200	.0175	4.04	.0662	66.204	.0146	2500	172	2500
20250	.0219	5.06	.0829	82.919	.0182	2500	172	2500
20300	.0262	6.05	.0992	99.142	.0218	2500	172	2500
20350	.0306	7.07	.1158	115.857	.0255	2500	172	2500
20400	.0350	8.08	.1325	132.408	.0292	2500	172	2500
20450	.0394	9.10	.1491	149.123	.0328	2500	172	2500

All data based on SAE 10W oil at 150°F.  
 Available with Viton Seals for use with phosphate ester base fluids.  
 \*Some models and sizes are available for pressure up to 3500 PSI. Cast-iron not available on all models. Consult factory for availability.

## How To Order

'A' denotes counterclockwise rotation  
 'C' denotes clockwise rotation  
 When viewed from drive shaft end

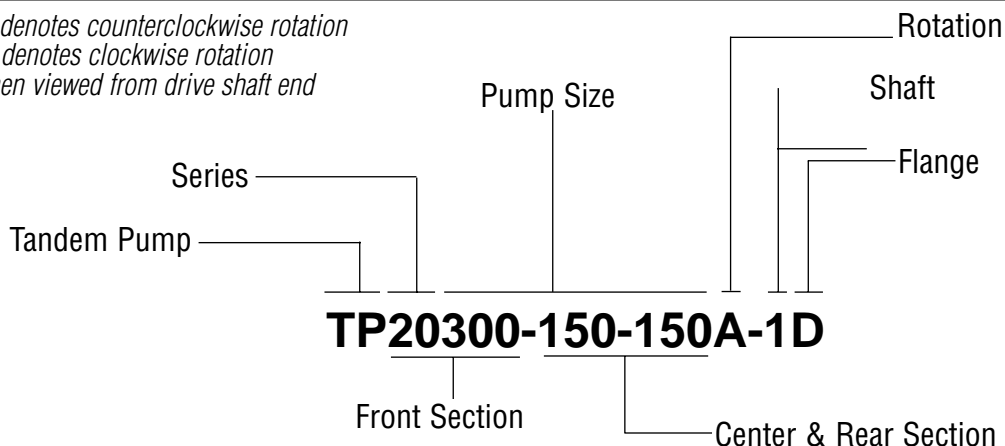

Note: Add prefix 'V' to pump model number (VTP20-) when ordering pumps with Viton Seals for use with phosphate ester base fluids.  
 Add prefix 'F' to pump model number (TFP20-) or (VTFP20-) when ordering pumps with cast iron construction.

## Shafts Available

<p><b>1</b> SAE 'C' 1-1/4" 14 Tooth Torque limit 655 Lbs. Ft.</p> <p>Spline Data          Diametral Pitch ..... 12/24          Pressure Angle ..... 30°          No. Of Teeth ..... 14          Minor Dia. .... 1.062-1.050</p>	<p><b>3</b> SAE 'C' 1-1/4" Straight Torque limit 655 Lbs. Ft.</p>	<p><b>5</b> 1-1/4" Straight Shaft Torque limit 655 Lbs. Ft.</p>
---	---	---

## Mounting Flanges Available

<p><b>D</b> SAE 'C' 4-Bolt</p>	<p><b>E</b> SAE 'B' 4-Bolt</p>
<p><b>F</b> SAE 'C' 2-Bolt</p>	<p><b>M</b> 'M' Pad Mount</p>

## Dimensional Data

### Front Section Suction & Discharge Ports

Front Section	Hole Dia.	Suction	Hole Dia.	Disc.	E	F
20150	1.25	1-1/4"	.75	3/4"	3.60	4.87
20200	1.25	1-1/4"	1.00	1"	3.75	5.81
20250	1.50	1-1/2"	1.19	1-1/4"	4.00	6.09
20300	1.50	1-1/2"	1.19	1-1/4"	4.14	6.37
20350	1.50	1-1/2"	1.19	1-1/4"	4.35	6.66
20400	2.00	2"	1.37	1-1/2"	4.35	6.94
20450	2.00	2"	1.37	1-1/2"	4.66	7.23

### Center and Rear Section Suction Ports

Section	Center	Rear	Hole Dia.	Common Suction	A	B	C	D
100-100			1.25	1-1/4"	3.05	7.13	8.77	3.05
150-100			1.50	1-1/2"	3.05	7.37	9.01	3.20
150-150			1.50	1-1/2"	3.05	7.37	9.29	3.20
200-100			1.50	1-1/2"	3.69	8.80	10.44	3.80
200-150			2.00	2"	3.69	8.80	10.72	3.80
200-200			2.00	2"	3.69	9.44	12.06	3.80
250-100			2.00	2"	3.94	9.08	10.72	3.94
250-150			2.00	2"	3.94	9.08	11.00	3.94
250-200			2.00	2"	3.94	9.72	12.34	3.94
250-250			2.00	2"	3.94	9.97	12.74	3.94
300-100			2.00	2"	4.08	9.37	11.00	4.08
300-150			2.00	2"	4.08	9.37	11.29	4.08
300-200			2.00	2"	4.08	10.01	12.63	4.08
300-250			2.00	2"	4.08	10.26	13.03	4.08
300-300			2.50	2-1/2"	4.08	10.26	13.31	4.08

### SAE 4-Bolt Connector Ports

Size	C	D	E	F	G
3/4"	.43	.875	.93	1.875	3/8-16NC
1"	.51	1.031	1.03	2.062	3/8-16NC
1-1/4"	.59	1.188	1.15	2.313	7/16-14NC
1-1/2"	.70	1.406	1.37	2.750	1/2-13NC
2"	.84	1.688	1.53	3.062	1/2-13NC
2-1/2"	1.00	2.000	1.75	3.500	1/2-13NC

### Center & Rear Discharge Ports

Section Size	Discharge Port for Center & Rear Section	Hole Diameter
100	3/4"	.75
150	3/4"	.75
200	1"	1.00
250	1-1/4"	1.19
300	1-1/4"	1.19

SAE 4-Bolt NPT Connectors are available. See Accessory Section

## Dimensional Data

### PD Factors

Drive Shaft	Factors
1-1/4"	187
3-1/4"	187
5-1/4"	187
Coupling	110

The maximum size and number of sections of a tandem pump for a given application is limited to the torque capability of the input drive shaft and the spline coupling between the sections. To determine this capability, a "PD Factor" is used:

P = PSI (The relief valve setting of each individual section).

D = Displacement (In U.S. gallons per revolution of each individual section).

*Example:* Assume a triple pump TP20450-450-450 A-3D with front and center sections on pressure at the same time at 2000 PSI, and with the rear section on pressure at 1500 PSI but not at the same time as the front and center sections:

**A. Drive Shaft:**

(1)  $PD = (2000) (.0394) + (2000) (.0394) = 157.6$  vs. 187. Capability is OK

(2)  $PD = (1500) (.0394) = 59.1$  vs. 187. Capability is OK.

**B. Coupling between front and center sections:**

(1)  $PD = (2000) (.0394) = 78.8$  vs. 110. Capability is OK.

**C. Coupling between center and rear sections:**

(1)  $PD = (1500) (.0394) = 59.1$  vs. 110. Capability is OK.

*Note:* For purpose of illustration, assume all three pump sections to be on pressure at the same time.

**A. Drive Shaft:**

$PD = (2000) (.0394) + (2000) (.0394) = (1500) (.0394) = 216.7$ . Capability is not OK

The "PD Factor" for a No. 3 shaft is 187. Therefore, to operate all three sections at once (to relief valve pressure) would exceed the torque capability of the drive shaft.

**B. Coupling between front and center sections:**

(1)  $PD = (2000) (.0394) + (1500) (.0394) = 137.9$ . Capability is not OK.

The "PD Factor" for the coupling is 110. If the center and rear sections are on pressure at the same time, the coupling between the front and center sections must transmit the torque for the center and rear sections.

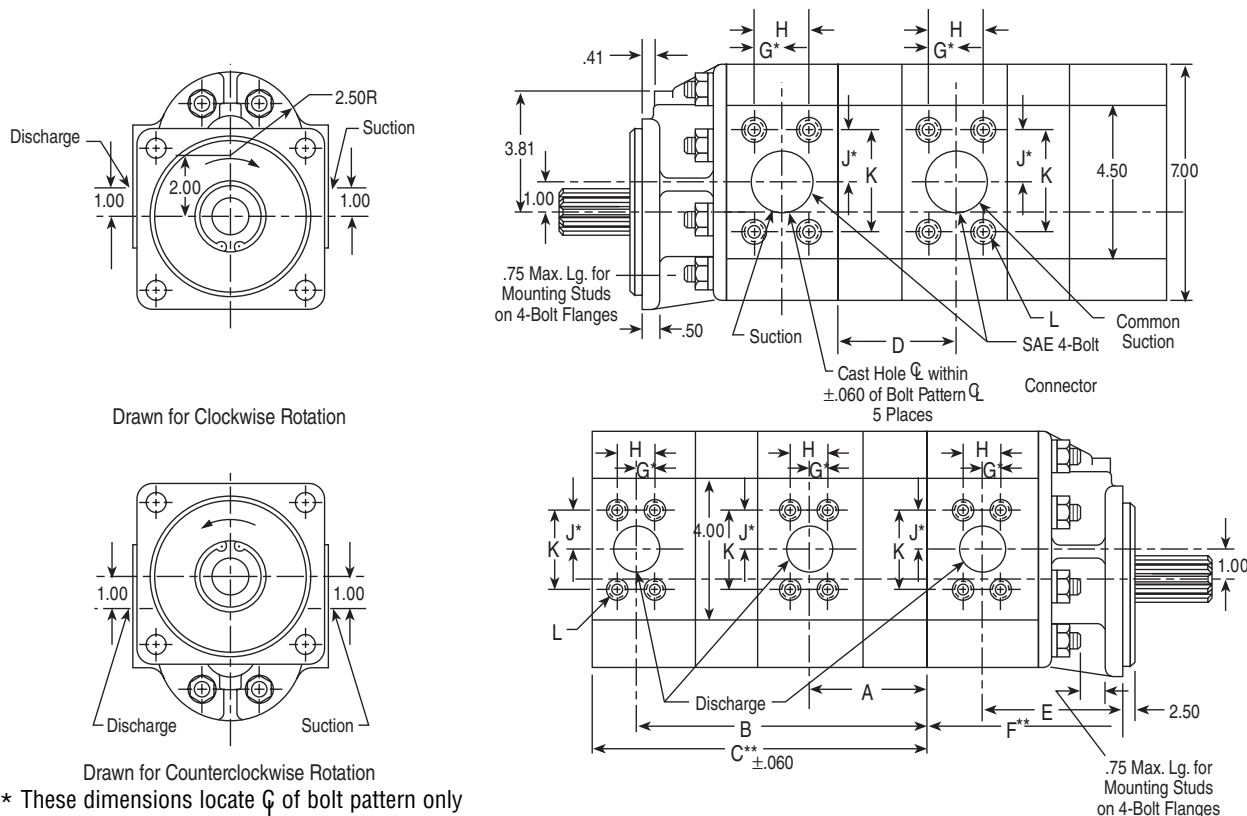

\* These dimensions locate  $\phi$  of bolt pattern only



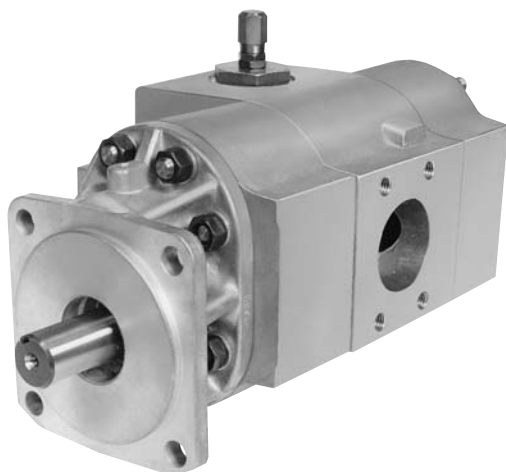

Series NST20

Description . Flow Sensitive Unloading Gear Pumps  
 Combined Flow Range . . . . . To 197 GPM  
 Displacements . . . . . To 9.10 Each Section  
 Maximum Pressure to . . . . . 2500 PSI  
 Maximum Speed to . . . . . 2500 RPM  
 Rotation . . . . . A or C  
 Bearings . . . . . Journal  
 Construction . . . . . Aluminum

### ***Tandem Pump with Flow Sensitive Unloading Valve***

At low pump speeds the flow from both pump sections is to the circuit. As speed increases one pump section begins to bypass internally to the suction of the active pump section. After approximately a 400 RPM spread, one pump is completely bypassing and only the flow of one pump is to the circuit. The bypass set point is field adjustable within approximately  $\pm 200$  RPM.

## Performance Data

PUMP SIZES	DISPLACEMENT/REVOLUTION (Theoretical)					MAXIMUM PRESSURE		MAXIMUM SPEED
	US Gallons	Cubic Inches	Liters	Cubic Centimeters	Imperial Gallons	PSI	BAR	RPM
20150	.0131	3.02	.0496	49.849	.0108	2500	172	2500
20200	.0175	4.04	.0662	66.204	.0146	2500	172	2500
20250	.0219	5.06	.0829	82.909	.0182	2500	172	2500
20300	.0262	6.05	.0992	99.142	.0218	2500	172	2500
20350	.0306	7.07	.1158	115.857	.0255	2500	172	2500
20400	.0350	8.08	.1325	132.408	.0292	2500	172	2500
20450	.0394	9.10	.1491	149.123	.0328	2500	172	2500

All data based on SAE 10W oil at 150°F.  
 Available with Viton Seals for use with phosphate ester based fluid.

## How To Order

'A' denotes counterclockwise rotation  
 'C' denotes clockwise rotation  
 When viewed from drive shaft end

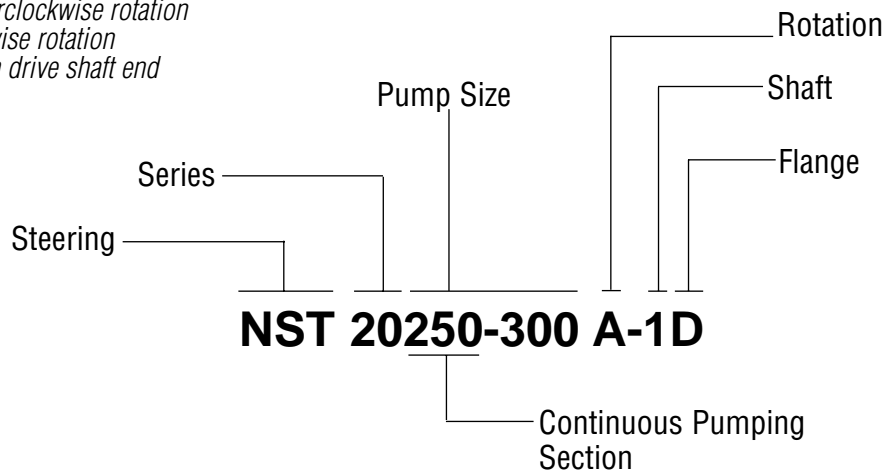

Note: Add prefix 'V' to pump model number (VNST20-) when ordering pumps with Viton Seals for use with phosphate ester base fluids.

## Shafts Available

<p><b>1</b> SAE 'C' 1-1/4" 14 Tooth Torque limited to 655 Lbs. Ft.</p> <p>Spline Data          Diametral Pitch ..... 12/24          Pressure Angle ..... 30°          No. Of Teeth ..... 14          Minor Dia. .... 1.062-1.050</p>	<p><b>3</b> SAE 'C' 1-1/4" Straight Torque limited to 655 Lbs. Ft.</p>	<p><b>5</b> 1-1/4" Straight Shaft Torque limited to 655 Lbs. Ft.</p>
--	--	--

## Flanges Available

<p><b>D</b> SAE 'C' 4-Bolt</p>	<p><b>E</b> SAE 'B' 4-Bolt</p>
<p><b>F</b> SAE 'C' 2-Bolt</p>	<p><b>F</b> Pad Mount</p>

## Dimensional Data

### Mounting Dimensions

FRONT SECTION SIZE	REAR SECTION SIZE	DISCHARGE Front Section		FRONT SECTION DIMENSIONS			SHIPPING WEIGHTS (Approx.)	
		Conn. Size	Hole Dia.	A	B	C	lbs.	kgs.
20150	—150	1"	.93	3.60	7.07	12.68	56	20.9
	—200	1"	.93	3.60	7.07	13.54	57	21.3
	—250	1"	.93	3.60	7.07	13.93	58	21.7
	—300	1"	.93	3.60	7.07	14.22	60	22.4
	—350	1"	.93	3.60	7.07	13.83	62	23.1
	—400	1"	.93	3.60	7.07	14.11	64	23.9
	—450	1"	.93	3.60	7.07	14.40	66	24.6
20200	—150	1-1/2"	1.19	3.75	7.97	13.58	58	21.7
	—200	1-1/2"	1.19	3.75	7.97	14.44	59	22.0
	—250	1-1/2"	1.19	3.75	7.97	14.83	60	22.4
	—300	1-1/2"	1.19	3.75	7.97	15.11	62	23.1
	—350	1-1/2"	1.19	3.75	7.97	14.72	64	23.9
	—400	1-1/2"	1.19	3.75	7.97	15.00	66	24.6
	—450	1-1/2"	1.19	3.75	7.97	15.29	68	25.4
20250	—150	1-1/2"	1.19	4.00	8.25	13.86	59	21.7
	—200	1-1/2"	1.19	4.00	8.25	14.71	60	22.4
	—250	1-1/2"	1.19	4.00	8.25	15.11	62	23.1
	—300	1-1/2"	1.19	4.00	8.25	15.39	64	23.9
	—350	1-1/2"	1.19	4.00	8.25	15.00	66	24.6
	—400	1-1/2"	1.19	4.00	8.25	15.28	68	25.4
	—450	1-1/2"	1.19	4.00	8.25	15.57	70	26.1
20300	—150	1-1/2"	1.19	4.14	8.54	14.15	60	22.4
	—200	1-1/2"	1.19	4.14	8.54	15.00	64	23.9
	—250	1-1/2"	1.19	4.14	8.54	15.40	66	24.6
	—300	1-1/2"	1.19	4.14	8.54	15.68	68	25.4
	—350	1-1/2"	1.19	4.14	8.54	15.29	70	26.1
	—400	1-1/2"	1.19	4.14	8.54	15.57	72	26.9
	—450	1-1/2"	1.19	4.14	8.54	15.86	74	27.6
20350	—150	1-1/2"	1.19	4.35	8.82	14.43	62	23.1
	—200	1-1/2"	1.19	4.35	8.82	15.28	64	23.9
	—250	1-1/2"	1.19	4.35	8.82	15.68	66	24.6
	—300	1-1/2"	1.19	4.35	8.82	15.96	70	26.1
	—350	1-1/2"	1.19	4.35	8.82	15.57	72	26.9
	—400	1-1/2"	1.19	4.35	8.82	15.85	74	27.6
	—450	1-1/2"	1.19	4.35	8.82	16.14	76	28.4
20400	—150	1-1/2"	1.37	4.35	9.10	14.71	64	23.9
	—200	1-1/2"	1.37	4.35	9.10	15.56	66	24.6
	—250	1-1/2"	1.37	4.35	9.10	15.96	68	25.4
	—300	1-1/2"	1.37	4.35	9.10	16.24	70	26.1
	—350	1-1/2"	1.37	4.35	9.10	15.85	72	26.9
	—400	1-1/2"	1.37	4.35	9.10	16.13	76	28.4
	—450	1-1/2"	1.37	4.35	9.10	16.42	78	29.1
20450	—150	1-1/2"	1.37	4.66	9.39	15.00	66	24.6
	—200	1-1/2"	1.37	4.66	9.39	15.85	68	25.4
	—250	1-1/2"	1.37	4.66	9.39	16.25	70	26.1
	—300	1-1/2"	1.37	4.66	9.39	16.53	74	27.6
	—350	1-1/2"	1.37	4.66	9.39	16.14	76	28.4
	—400	1-1/2"	1.37	4.66	9.39	16.42	78	29.1
	—450	1-1/2"	1.37	4.66	9.39	16.71	80	29.9

## Dimensional Data

### SAE 4-Bolt Connector Ports

Size	F	G	H	J	K
1"	.51	1.031	1.03	2.062	3/8-16NC
1-1/2"	.70	1.406	1.37	2.750	1/2-13NC

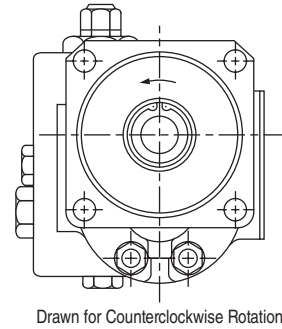
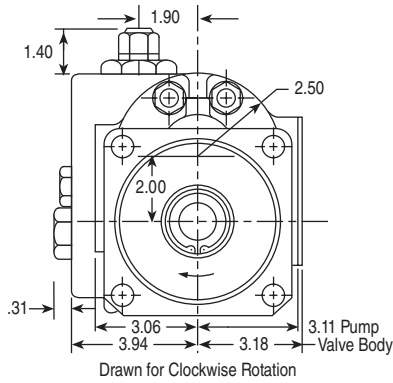

NOTE: Any Pump Combination with 350, 400 & 450 On Rear Will Use Cover Plate As Shown By Dotted Line.

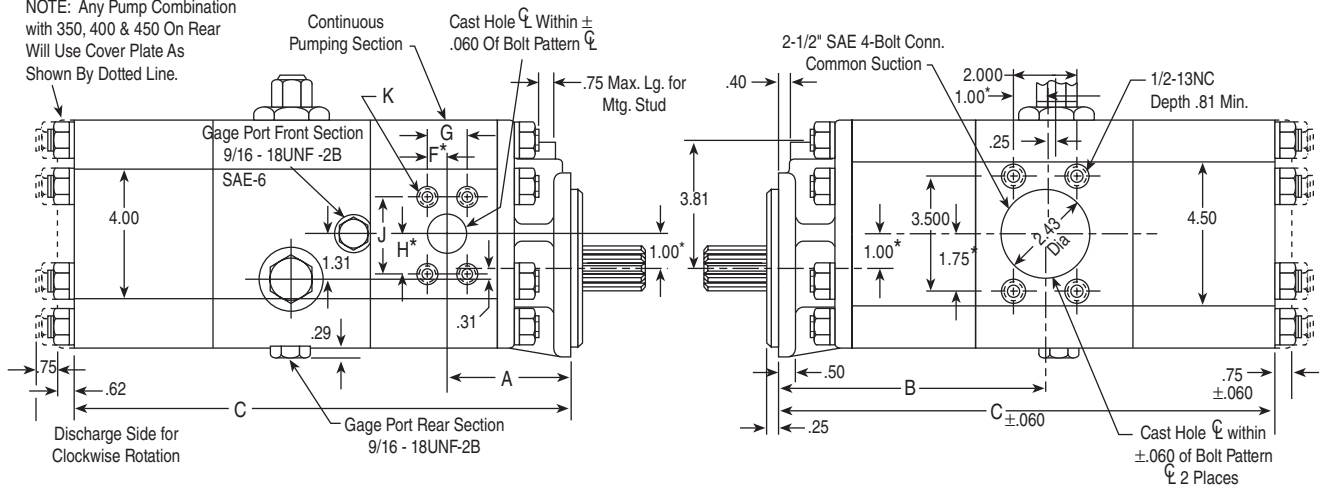

\* These dimensions locate CL of bolt pattern only

SAE 4-Bolt NPT Connectors are available. See Accessory Section

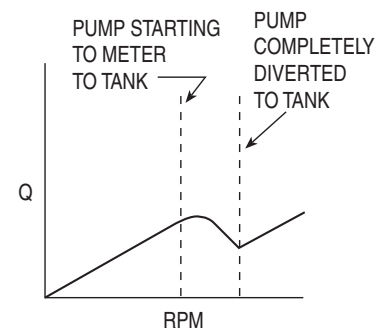
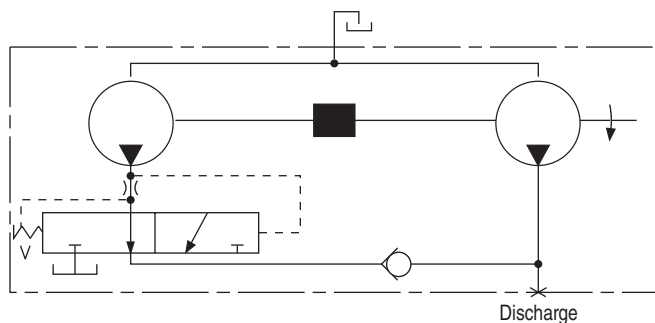

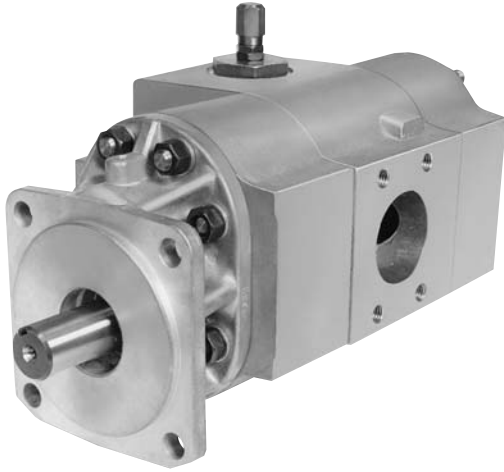

Series NSD20

Description . Flow Sensitive Unloading Gear Pumps  
 Combined Flow Range . . . . . To 197 GPM  
 Displacements . . . . . To 9.10 Each Section  
 Maximum Pressure to . . . . . 2500 PSI  
 Maximum Speed to . . . . . 2500 RPM  
 Rotation . . . . . A or C  
 Bearings . . . . . Journal  
 Construction . . . . . Aluminum

### ***Tandem Pump with Flow Sensitive Unloading Valve and Power Beyond Port For the Unloaded Pump***

This system consists of a tandem pump and unloading valve with the unloaded valve being sensitive to pump speed. The system has primary and secondary discharge ports such that both pumps are diverted to the primary port at low pump speeds. At an intermediate pump speed, one of the tandem pumps is metered from the primary port and a portion is diverted to the secondary port. At a predetermined higher speed, the pump is completely diverted to the secondary port.

## Performance Data

PUMP SIZES	DISPLACEMENT/REVOLUTION (Theoretical)					MAXIMUM PRESSURE		MAXIMUM SPEED
	US Gallons	Cubic Inches	Liters	Cubic Centimeters	Imperial Gallons	PSI	BAR	RPM
	20150	.0131	3.02	.0496	49.849	.0108	2500	172
20200	.0175	4.04	.0662	66.204	.0146	2500	172	2500
20250	.0219	5.06	.0829	82.919	.0182	2500	172	2500
20300	.0262	6.05	.0992	99.142	.0218	2500	172	2500
20350	.0306	7.07	.1158	115.857	.0255	2500	172	2500
20400	.0350	8.08	.1325	132.408	.0292	2500	172	2500
20450	.0394	9.10	.1491	149.123	.0328	2500	172	2500

All data based on SAE 10W oil at 150°F.  
 Available with Viton Seals for use with phosphate ester based fluid.

## How To Order

'A' denotes counterclockwise rotation  
 'C' denotes clockwise rotation  
 When viewed from drive shaft end

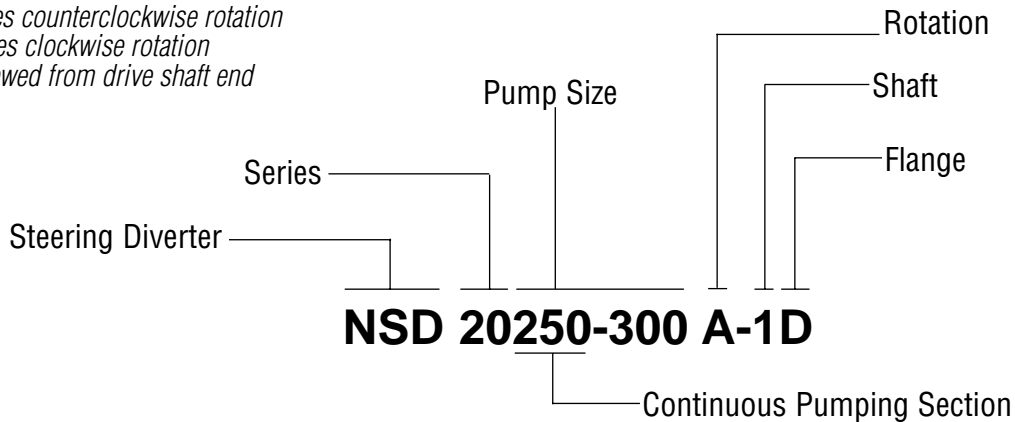

Note: Add prefix 'V' to pump model number (VNSD20-) when ordering pumps with Viton Seals for use with phosphate ester base fluids.

## Shafts Available

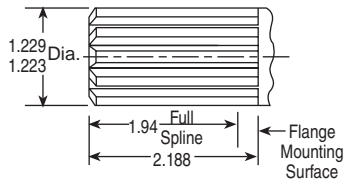
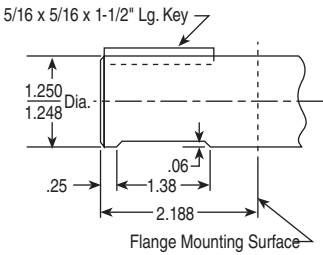
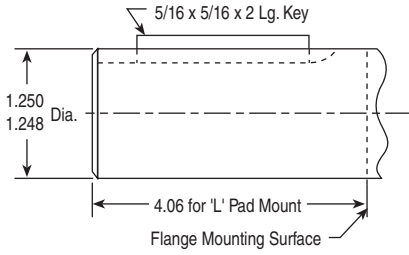
<p><b>1</b> SAE 'C' 1-1/4" 14 Tooth Torque limited to 655 Lbs. Ft.</p>  <p>Spline Data          Diametral Pitch ..... 12/24          Pressure Angle ..... 30°          No. Of Teeth ..... 14          Minor Dia. .... 1.062-1.050</p>	<p><b>3</b> SAE 'C' 1-1/4" Straight Torque limited to 655 Lbs. Ft.</p> 	<p><b>5</b> 1-1/4" Straight Shaft Torque limited to 655 Lbs. Ft.</p> 
--	--	--

## Flanges Available

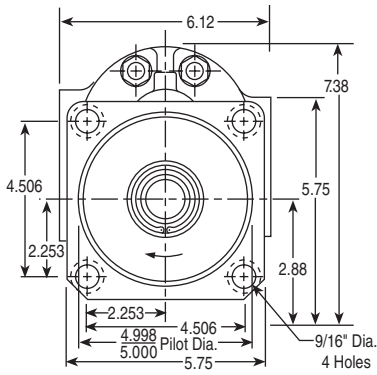
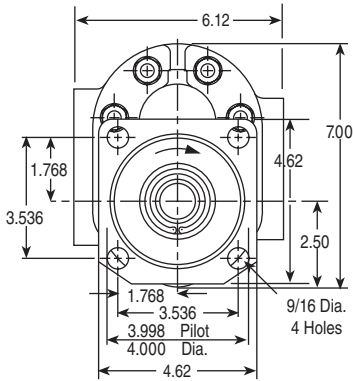
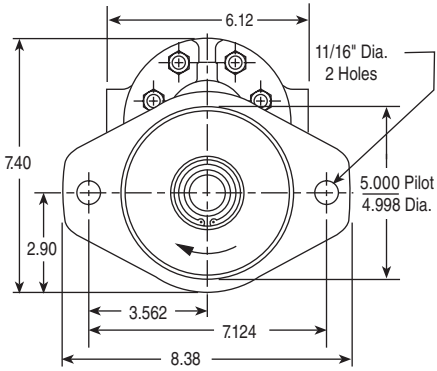
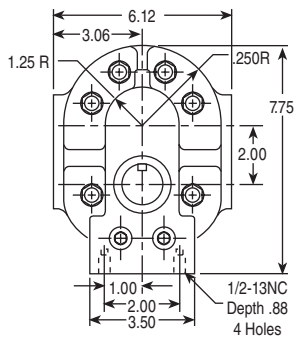
<p><b>D</b> SAE 'C' 4-Bolt</p> 	<p><b>E</b> SAE 'B' 4-Bolt</p> 
<p><b>F</b> SAE 'C' 2-Bolt</p> 	<p><b>F</b> Pad Mount</p> 

## Dimensional Data

### Mounting Dimensions

FRONT SECTION SIZE	REAR SECTION SIZE	DISCHARGE Front Section		A	B	C	D	SHIPPING WEIGHTS (Approx.)	
		Conn. Size	Hole Dia.					lbs.	kgs.
20150	—150	1"	.93	3.60	7.07	12.68	7.28	56	20.9
	—200	1"	.93	3.60	7.07	13.54	7.28	57	21.3
	—250	1"	.93	3.60	7.07	13.93	7.28	58	21.7
	—300	1"	.93	3.60	7.07	14.22	7.28	60	22.4
	—350	1"	.93	3.60	7.07	13.83	7.28	62	23.1
	—400	1"	.93	3.60	7.07	14.11	7.28	64	23.9
	—450	1"	.93	3.60	7.07	14.40	7.28	66	24.6
20200	—150	1-1/2"	1.19	3.75	7.97	13.58	8.18	58	21.7
	—200	1-1/2"	1.19	3.75	7.97	14.44	8.18	59	22.0
	—250	1-1/2"	1.19	3.75	7.97	14.83	8.18	60	22.4
	—300	1-1/2"	1.19	3.75	7.97	15.11	8.18	62	23.1
	—350	1-1/2"	1.19	3.75	7.97	14.72	8.18	64	23.9
	—400	1-1/2"	1.19	3.75	7.97	15.00	8.18	66	24.6
	—450	1-1/2"	1.19	3.75	7.97	15.29	8.18	68	25.4
20250	—150	1-1/2"	1.19	4.00	8.25	13.86	8.46	59	21.7
	—200	1-1/2"	1.19	4.00	8.25	14.71	8.46	60	22.4
	—250	1-1/2"	1.19	4.00	8.25	15.11	8.46	62	23.1
	—300	1-1/2"	1.19	4.00	8.25	15.39	8.46	64	23.9
	—350	1-1/2"	1.19	4.00	8.25	15.00	8.46	66	24.6
	—400	1-1/2"	1.19	4.00	8.25	15.28	8.46	68	25.4
	—450	1-1/2"	1.19	4.00	8.25	15.57	8.46	70	26.1
20300	—150	1-1/2"	1.19	4.14	8.54	14.15	8.75	60	22.4
	—200	1-1/2"	1.19	4.14	8.54	15.00	8.75	64	23.9
	—250	1-1/2"	1.19	4.14	8.54	15.40	8.75	66	24.6
	—300	1-1/2"	1.19	4.14	8.54	15.68	8.75	68	25.4
	—350	1-1/2"	1.19	4.14	8.54	15.29	8.75	70	26.1
	—400	1-1/2"	1.19	4.14	8.54	15.57	8.75	72	26.9
	—450	1-1/2"	1.19	4.14	8.54	15.86	8.75	74	27.6
20350	—150	1-1/2"	1.19	4.35	8.82	14.43	9.03	62	23.1
	—200	1-1/2"	1.19	4.35	8.82	15.28	9.03	64	23.9
	—250	1-1/2"	1.19	4.35	8.82	15.68	9.03	66	24.6
	—300	1-1/2"	1.19	4.35	8.82	15.96	9.03	70	26.1
	—350	1-1/2"	1.19	4.35	8.82	15.57	9.03	72	26.9
	—400	1-1/2"	1.19	4.35	8.82	15.85	9.03	74	27.6
	—450	1-1/2"	1.19	4.35	8.82	16.14	9.03	76	28.4
20400	—150	1-1/2"	1.37	4.35	9.10	14.71	9.31	64	23.9
	—200	1-1/2"	1.37	4.35	9.10	15.56	9.31	66	24.6
	—250	1-1/2"	1.37	4.35	9.10	15.96	9.31	68	25.4
	—300	1-1/2"	1.37	4.35	9.10	16.24	9.31	70	26.1
	—350	1-1/2"	1.37	4.35	9.10	15.85	9.31	72	26.9
	—400	1-1/2"	1.37	4.35	9.10	16.13	9.31	76	28.4
	—450	1-1/2"	1.37	4.35	9.10	16.42	9.31	78	29.1
20450	—150	1-1/2"	1.37	4.66	9.39	15.00	9.61	66	24.6
	—200	1-1/2"	1.37	4.66	9.39	15.85	9.61	68	25.4
	—250	1-1/2"	1.37	4.66	9.39	16.25	9.61	70	26.1
	—300	1-1/2"	1.37	4.66	9.39	16.53	9.61	74	27.6
	—350	1-1/2"	1.37	4.66	9.39	16.14	9.61	76	28.4
	—400	1-1/2"	1.37	4.66	9.39	16.42	9.61	78	29.1
	—450	1-1/2"	1.37	4.66	9.39	16.71	9.61	80	29.9

## Dimensional Data

### SAE 4-Bolt Connector Ports

Size	F	G	H	J	K
1"	.51	1.031	1.03	2.062	3/8-16NC
1-1/2"	.70	1.406	1.37	2.750	1/2-13NC

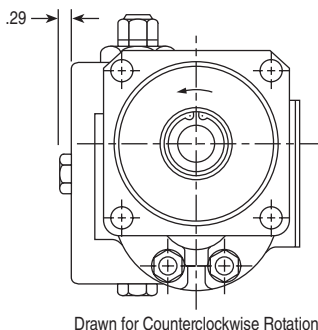
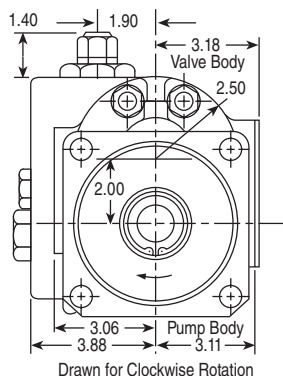

NOTE: Any Pump Combination with 350, 400 & 450 On Rear Will Use Cover Plate As Shown By Dotted Line.

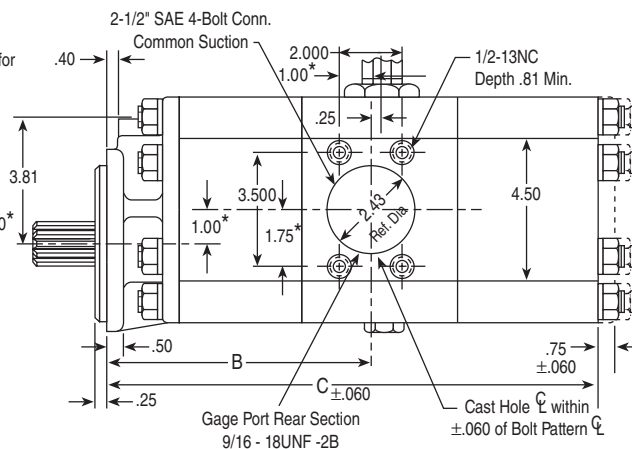
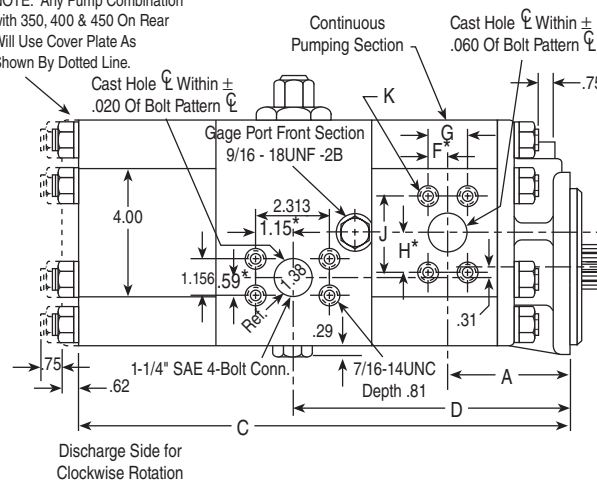

\* These dimensions locate  $\varnothing$  of bolt pattern only

SAE 4-Bolt NPT Connectors are available. See Accessory Section

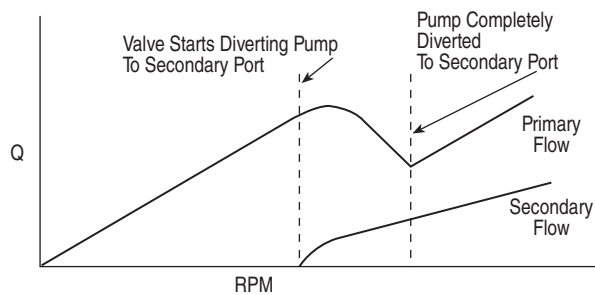
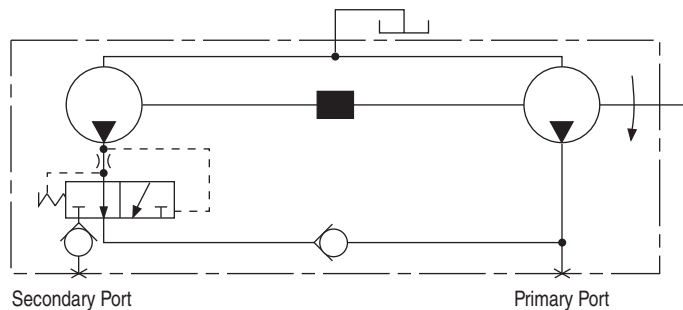



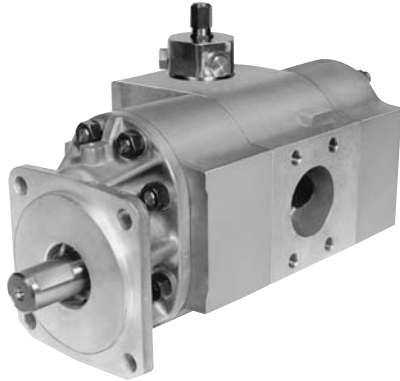

Series NDS20

Description . . . . . Pressure Summation Unloading Gear Pumps  
 Combined Flow Range . . . . . To 197 GPM  
 Displacements . . . . . To 9.10 Each Section  
 Maximum Pressure to . . . . . 2500 PSI  
 Maximum Speed to . . . . . 2500 RPM  
 Rotation . . . . . A or C  
 Bearings . . . . . Journal  
 Construction . . . . . Aluminum

## Tandem Pump with Pressure Summation Unloading Valve

The NDS pump system is essentially the same as the NSH system, except the unloading pressure signal is the summation of the internal pressure, plus an external pressure from another pumping system. The NDS system is useful in limiting the horsepower withdrawn from the prime mover in a multiple pump circuit system. Refer to Figure 1, Page 106, for a typical circuit. Assume System B is operating at minimum pressure, then the NDS circuit (System A) can operate at a high pressure-high flow before unloading one of the tandem pumps.

Conversely, if System B is operating at high pressure, then the NDS circuit (System A) would unload the pump at a lower pressure to avoid overloading the engine. This relationship is shown in Figure 2, which illustrates the unloading characteristics for the NDS system when used in conjunction with another hydraulic Pump B.

## Performance Data

PUMP SIZES	DISPLACEMENT/REVOLUTION (Theoretical)					MAXIMUM PRESSURE		MAXIMUM SPEED
	US Gallons	Cubic Inches	Liters	Cubic Centimeters	Imperial Gallons	PSI	BAR	RPM
	20150	.0131	3.02	.0496	49.849	.0108	2500	172
20200	.0175	4.04	.0662	66.204	.0146	2500	172	2500
20250	.0219	5.06	.0829	82.919	.0182	2500	172	2500
20300	.0262	6.05	.0992	99.142	.0218	2500	172	2500
20350	.0306	7.07	.1158	115.857	.0255	2500	172	2500
20400	.0350	8.08	.1325	132.408	.0292	2500	172	2500
20450	.0394	9.10	.1491	149.123	.0328	2500	172	2500

All data based on SAE 10W oil at 150°F.  
 Available with Viton Seals for use with phosphate ester based fluid.

## How To Order

'A' denotes counterclockwise rotation  
 'C' denotes clockwise rotation  
 When viewed from drive shaft end

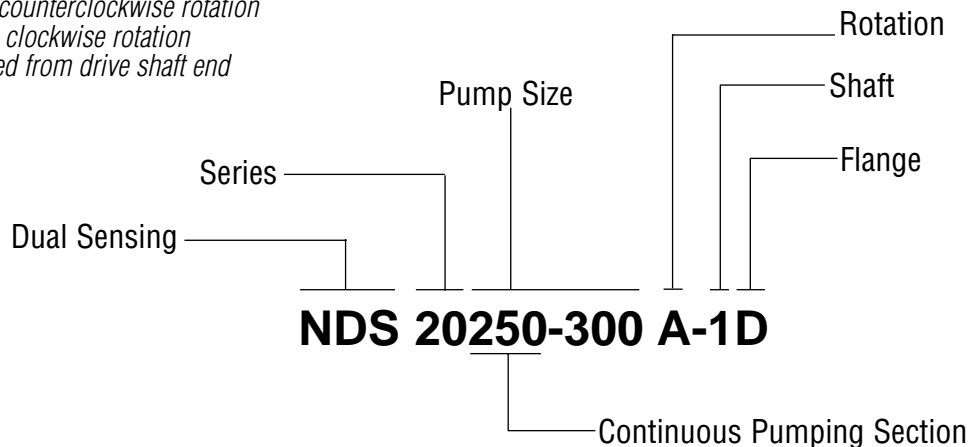

Note: Add prefix 'V' to pump model number (VNDS20-) when ordering pumps with Viton Seals for use with phosphate ester base fluids.

## Shafts Available

<p><b>1</b> SAE 'C' 1-1/4" 14 Tooth Torque limited to 655 Lbs. Ft.</p> <p>Spline Data          Diametral Pitch ..... 12/24          Pressure Angle ..... 30°          No. Of Teeth ..... 14          Minor Dia. .... 1.062-1.050</p>	<p><b>3</b> SAE 'C' 1-1/4" Straight Torque limited to 655 Lbs. Ft.</p>	<p><b>5</b> 1-1/4" Straight Shaft Torque limited to 655 Lbs. Ft.</p>
--	--	--

## Mounting Flanges Available

<p><b>D</b> SAE 'C' 4-Bolt</p>	<p><b>E</b> SAE 'B' 4-Bolt</p>
<p><b>F</b> SAE 'C' 2-Bolt</p>	<p><b>M</b> Pad Mount</p>

## Dimensional Data

### Mounting Dimensions

FRONT SECTION SIZE	REAR SECTION SIZE	DISCHARGE Front Section		A	B	C	SHIPPING WEIGHTS (Approx.)	
		Conn. Size	Hole Dia.				lbs.	kgs.
20150	—150	1"	.93	3.60	7.07	12.68	56	20.9
	—200	1"	.93	3.60	7.07	13.54	57	21.3
	—250	1"	.93	3.60	7.07	13.93	58	21.7
	—300	1"	.93	3.60	7.07	14.22	60	22.4
	—350	1"	.93	3.60	7.07	13.83	62	23.1
	—400	1"	.93	3.60	7.07	14.11	64	23.9
	—450	1"	.93	3.60	7.07	14.40	66	24.6
20200	—150	1-1/2"	1.19	3.75	7.97	13.58	58	21.7
	—200	1-1/2"	1.19	3.75	7.97	14.44	59	22.0
	—250	1-1/2"	1.19	3.75	7.97	14.83	60	22.4
	—300	1-1/2"	1.19	3.75	7.97	15.11	62	23.1
	—350	1-1/2"	1.19	3.75	7.97	14.72	64	23.9
	—400	1-1/2"	1.19	3.75	7.97	15.00	66	24.6
	—450	1-1/2"	1.19	3.75	7.97	15.29	68	25.4
20250	—150	1-1/2"	1.19	4.00	8.25	13.86	59	21.7
	—200	1-1/2"	1.19	4.00	8.25	14.71	60	22.4
	—250	1-1/2"	1.19	4.00	8.25	15.11	62	23.1
	—300	1-1/2"	1.19	4.00	8.25	15.39	64	23.9
	—350	1-1/2"	1.19	4.00	8.25	15.00	66	24.6
	—400	1-1/2"	1.19	4.00	8.25	15.28	68	25.4
	—450	1-1/2"	1.19	4.00	8.25	15.57	70	26.1
20300	—150	1-1/2"	1.19	4.14	8.54	14.15	60	22.4
	—200	1-1/2"	1.19	4.14	8.54	15.00	64	23.9
	—250	1-1/2"	1.19	4.14	8.54	15.40	66	24.6
	—300	1-1/2"	1.19	4.14	8.54	15.68	68	25.4
	—350	1-1/2"	1.19	4.14	8.54	15.29	70	26.1
	—400	1-1/2"	1.19	4.14	8.54	15.57	72	26.9
	—450	1-1/2"	1.19	4.14	8.54	15.86	74	27.6
20350	—150	1-1/2"	1.19	4.35	8.82	14.43	62	23.1
	—200	1-1/2"	1.19	4.35	8.82	15.28	64	23.9
	—250	1-1/2"	1.19	4.35	8.82	15.68	66	24.6
	—300	1-1/2"	1.19	4.35	8.82	15.96	70	26.1
	—350	1-1/2"	1.19	4.35	8.82	15.57	72	26.9
	—400	1-1/2"	1.19	4.35	8.82	15.85	74	27.6
	—450	1-1/2"	1.19	4.35	8.82	16.14	76	28.4
20400	—150	1-1/2"	1.37	4.35	9.10	14.71	64	23.9
	—200	1-1/2"	1.37	4.35	9.10	15.56	66	24.6
	—250	1-1/2"	1.37	4.35	9.10	15.96	68	25.4
	—300	1-1/2"	1.37	4.35	9.10	16.24	70	26.1
	—350	1-1/2"	1.37	4.35	9.10	15.85	72	26.9
	—400	1-1/2"	1.37	4.35	9.10	16.13	76	28.4
	—450	1-1/2"	1.37	4.35	9.10	16.42	78	29.1
20450	—150	1-1/2"	1.37	4.66	9.39	15.00	66	24.6
	—200	1-1/2"	1.37	4.66	9.39	15.85	68	25.4
	—250	1-1/2"	1.37	4.66	9.39	16.25	70	26.1
	—300	1-1/2"	1.37	4.66	9.39	16.53	74	27.6
	—350	1-1/2"	1.37	4.66	9.39	16.14	76	28.4
	—400	1-1/2"	1.37	4.66	9.39	16.42	78	29.1
	—450	1-1/2"	1.37	4.66	9.39	16.71	80	29.9

## Dimensional Data

### SAE 4-Bolt Connector Ports

Size	F	G	H	J	K
1"	.51	1.031	1.03	2.062	3/8-16NC
1-1/2"	.70	1.406	1.37	2.750	1/2-13NC

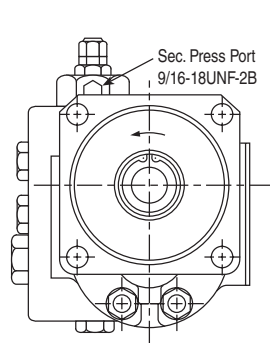

Drawn for Counterclockwise Rotation

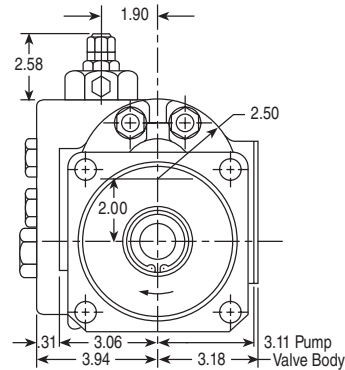

Drawn for Clockwise Rotation

NOTE: Any Pump Combination with 350, 400 & 450 On Rear Will Use Cover Plate As Shown By Dotted Line.

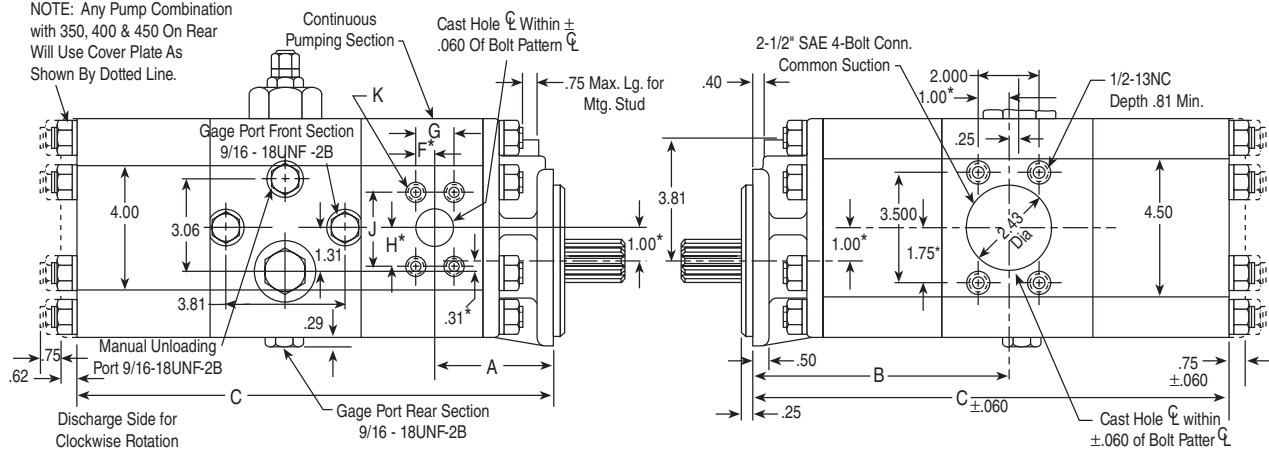

\* These dimensions locate  $\phi$  of bolt pattern only

SAE 4-Bolt NPT Connectors are available. See Accessory Section

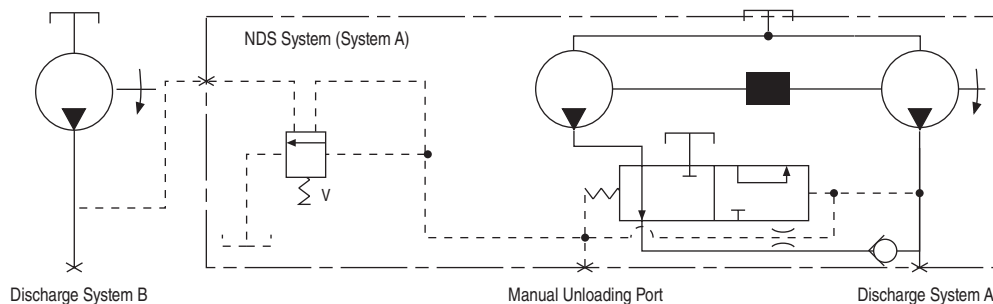

FIGURE 1

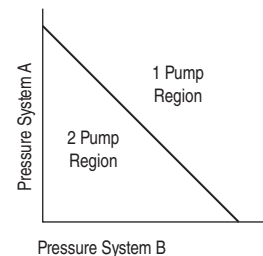
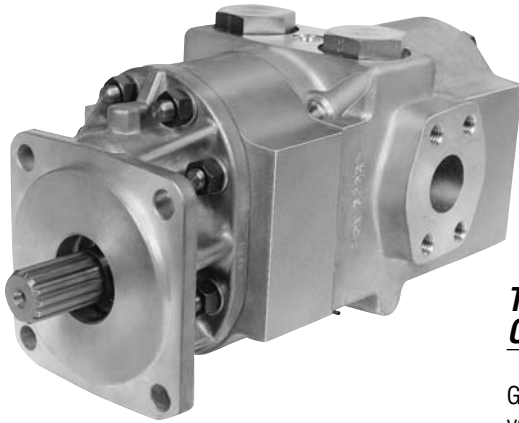

FIGURE 2



Series SPM20

Description . . . . . Two-Speed Gear Motors  
 Flow Range . . . . . To 98 GPM Per Section  
 Displacements . . . . . To 9.10 C.I.R. Per Section  
 Maximum Pressure to . . . . . 2500 PSI  
 Maximum Speed to . . . . . 2500 RPM  
 Rotation . . . . . Bi-Directional  
 Bearings . . . . . Journal  
 Construction . . . . . Aluminum

### ***Tandem Motor With Valving To Provide Two-Speed Operation On Constant Input Flow***

Gresen two-speed motors consist of two hydraulic motor units and pilot operated valving. From this unique unit either high speed or high torque can be obtained, thereby improving the efficiency of wench drives, track drives, and hydrostatic transmissions. Main features of these units are: *No external pilot pressure source is necessary. Shift to different speed is extremely smooth. Motor will not hesitate during shift. Displacement of the two motors need not be equal. One inlet and one outlet, fully reversible.*

The two motor sections are connected through valving to the common inlet/outlet ports. For low speed, high torque output, the pilot port is vented to tank. For higher speed, lower torque, the pilot port is blocked, causing the internal valves to shift to the closed position, routing the total flow through the rear motor section. The front motor section receives lubrication oil through the valve section and requires very little horsepower in this position since it is only recirculating.

## Performance Data

MOTOR SIZES	DISPLACEMENT/REVOLUTION (Theoretical)					Lb.-In. Torque at 2500 PSI <sup>(2)</sup> Run	H.P. at Max. RPM Max. PSI <sup>(2)</sup>	Max. Limits		
	US Gallons	Cubic Inches	Liters	Cubic Centimeters	Imperial Gallons			Pressure		Speed
								PSI	BAR	RPM
20150	.0131	3.02	.0496	49.849	.011	1050	26	2500	172	2500
20200	.0175	4.04	.0662	66.204	.015	1400	34	2500	172	2500
20250	.0219	5.06	.0829	82.919	.018	1750	42	2500	172	2500
20300	.0262	6.05	.0992	99.142	.022	2100	50	2500	172	2500
20350	.0306	7.07	.1158	115.857	.025	2450	58	2500	172	2500
20400	.0350	8.08	.1325	132.408	.029	2800	66	2500	172	2500
20450	.0394	9.10	.1461	149.123	.033	3150	74	2500	172	2500

Available with Viton Seals for use with phosphate ester base fluids. All data based on SAE 10W oil at 135°F.

## How To Order

'A' denotes counterclockwise rotation  
 'C' denotes clockwise rotation  
 When viewed from drive shaft end

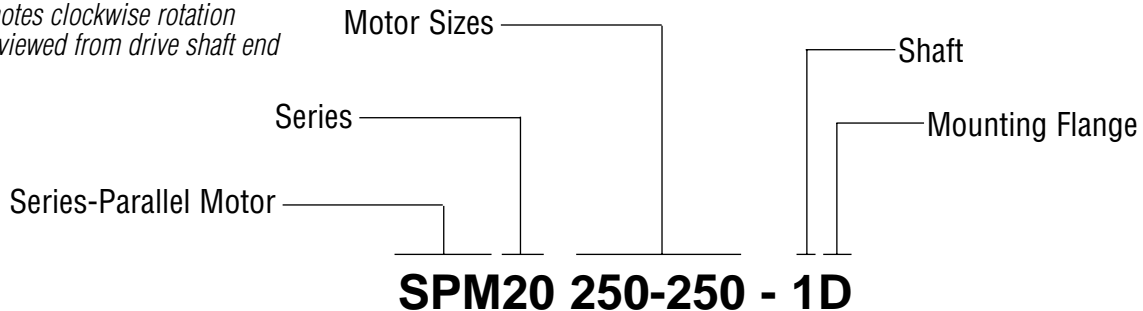

## Shafts Available

**1** SAE 'C' 1-1/4" 14-Tooth Spline  
Torque Limit 655 Lbs. Ft.

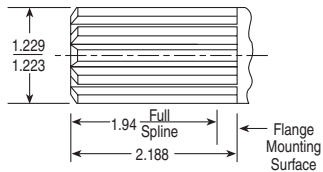

**Spline Data**

Diametral Pitch . . . . . 12/24  
Pressure Angle . . . . . 30°  
No. Of Teeth . . . . . 14  
Minor Dia. . . . . 1.062-1.050

**3** SAE 'C' 1-1/4" Straight Shaft  
Torque Limit 655 Lbs. Ft.

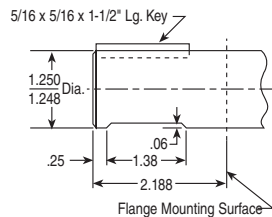

## Mounting Flanges Available

**D** SAE 'C' 4-Bolt

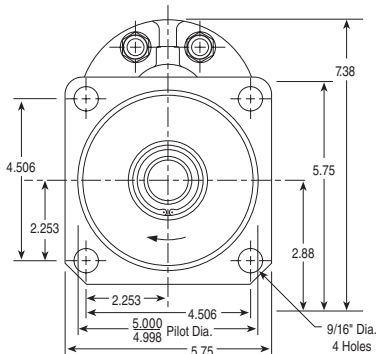

**E** SAE 'B' 4-Bolt

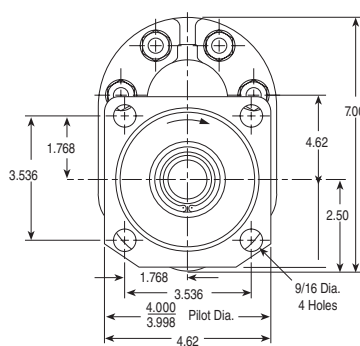

**F** SAE 'C' 2-Bolt

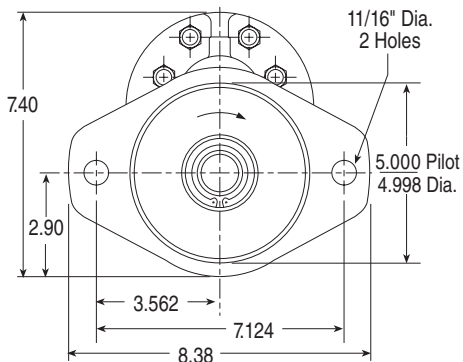

**N** SAE 'B' 2-Bolt

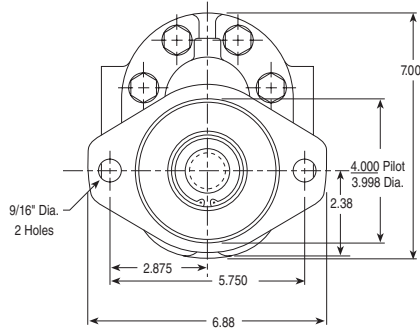

## Dimensional Data

### Mounting Dimensions

MOTOR SIZES	A	B
SPM20150-150	8.03	12.68
SPM20200-200	8.93	14.43
SPM20250-250	9.21	15.11
SPM20300-300	9.49	15.67
SPM20350-350	9.78	15.57
SPM25400-400	10.06	16.13
SPM20450-450	10.35	16.71

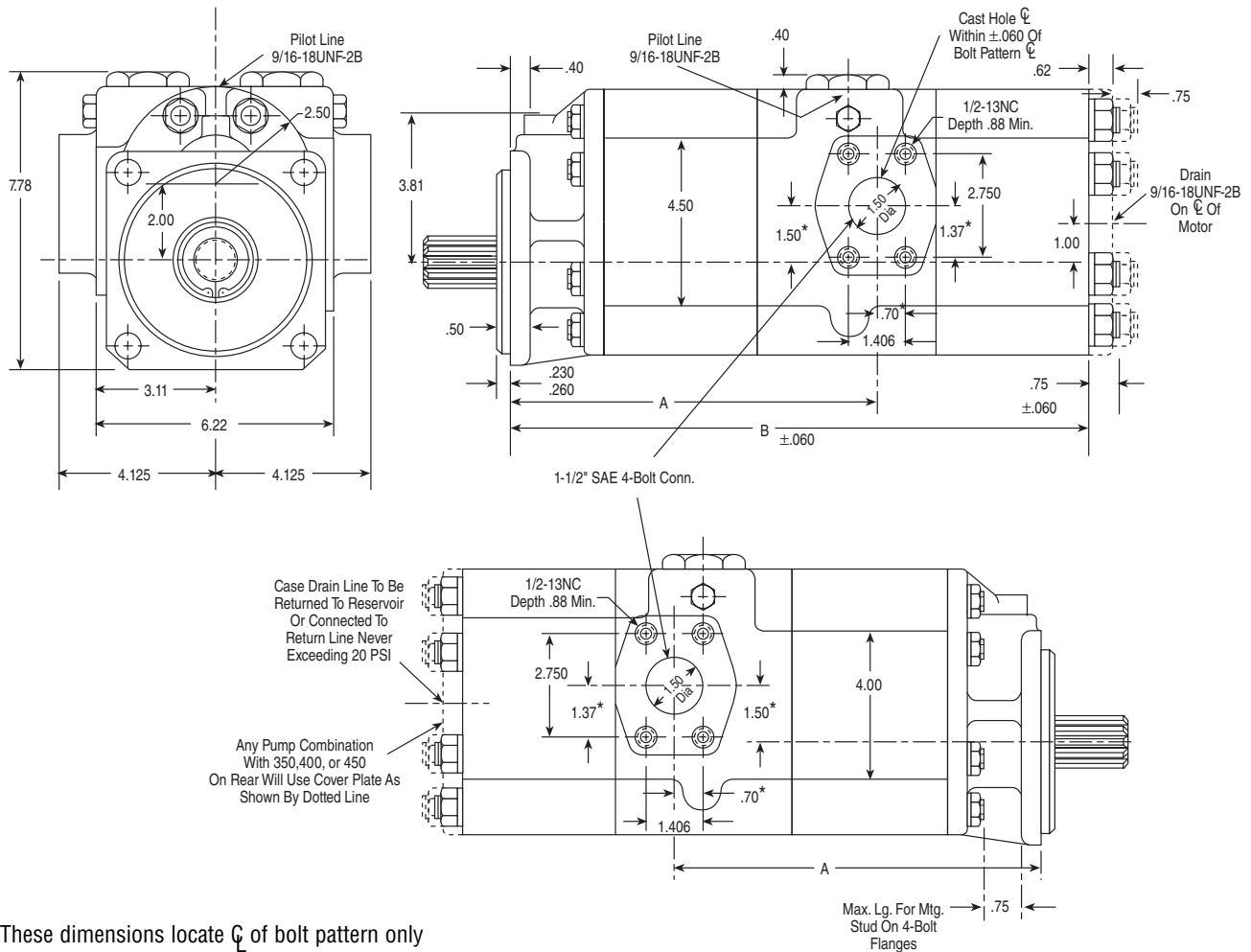

\* These dimensions locate  $\phi$  of bolt pattern only

SAE 4-Bolt NPT Connectors are available. See Accessory Section