



One Sprint. Many Solutions.SM

User's Guide

**PCS Vision Picture Phone
with Built-in Camera
(Hitachi SH-G1000)**

HITACHI

Table of Contents

Welcome to Sprint	1
Introduction to This Online User's Guide	3
SECTION 1: Getting Started	5
1A. Setting Up Service	7
Getting Started With PCS Service	8
Setting Up Your Voicemail	8
Getting Help	9
SECTION 2: Understanding Your Device	11
2A. Your PCS Phone – The Basics	13
Your PCS Phone's Features	14
Using the Batteries	16
Installing the Main Battery	16
Removing the Main Battery	18
Charging the Battery	20
Battery Life	22
Battery Operating Time	22
Extending the Maximum Battery Operating Time	23
Data Backup Time	24
Resetting	25
Initialization	26
Turning Your Device ON and OFF	28
Turning the Device On and Off	28
Turning the Phone On and Off	28
LEDs	29
USB Cradle	30
Using the USB Port	32
Using the Infrared Communications Port	33
Using SD Card / MultiMediaCard	34
Using the Optional Headset	36
Camera	37
Jog Wheel	38
Talk Button	38
End Button	39
Speaker Phone Button	39
Voice Button	40
Volume Button	40
Key Guard Switch	41

Environment Switch	42
Using the Keyboard	43
Adjusting the Screen Brightness	44
Using the Stylus	44
Initial Setup	45
Provisioning	46
Today Screen	47
Navigation Bar and Command Bar	49
Programs	51
Pop-up Menus	53
Notifications	53
Entering Information on Your Device	54
Entering Text Using the Input Panel	54
Writing on the Screen	57
Drawing on the Screen	60
Recording a Message	62
Using My Text	64
Finding and Organizing Information	65

2B. Using Your Phone 67

Viewing the Display Screen	68
Dialer Screen	68
Keypad Operation List	68
Signal Indicator and Icon	70
Status Icon	71
Turning the Phone ON and OFF	72
Displaying Your Phone Number	72
Making and Answering Calls	73
Making Calls	73
Answering Calls	73
Calling Emergency Numbers	74
Making a Call From the Internal Phone Book	74
Making a Call From Speed Dial	75
Making a Call From Call History	75
Making a Call From 4/5 Digit Dial	76
Making a Call From Voice Dial	76
Using Memo	76
Using Speaker Phone	77

2C. Controlling the Phone Function's Settings 79

Changing the Voicemail Number	80
Changing the Ringer and Key Beep Settings	80

Changing the Location Setting	81
Changing the Settings for Individual Modes	82
Data	83
Changing the Others Settings	84
Phone Info	86
TTY	87
2D. Controlling Your Device's Settings	89
Adjusting Settings	90
Adding or Removing Programs	91
Setting Buttons	94
Setting a Password	95
Selecting Sounds & Notifications Settings	96
Selecting Backlight Settings	97
Adjusting Memory Settings	98
Setting the Microphone	99
Adjusting Power Settings	100
Customizing Regional Settings	101
2E. Controlling Your Roaming Experience	103
Understanding Roaming	104
Setting Your Device's Roam Mode	104
Controlling Roaming Charges Using Call Guard	105
2F. Managing Call History	107
Viewing History	108
Call History Options	109
Making a Call From Call History	109
Saving a Phone Number From Call History	109
Erasing Call History	110
2G. Using Microsoft Pocket Outlook	111
Contacts: Tracking Friends and Colleagues	112
Creating a Contact	113
Finding a Contact	113
Using the Summary Screen	114
Making a Call From Contacts	114
Assigning a Picture to a Contact (Picture Display Mode)	115
Calendar: Scheduling Appointments and Meetings	116
Creating an Appointment	117
Using the Summary Screen	118
Creating Meeting Requests	118
Tasks: Keeping a To Do List	119

Creating a Task	120
Using the Summary Screen	121
Notes: Capturing Thoughts and Ideas	122
Creating a Note	123
2H. Using Your Phone's Voice Services	125
Using Voice-Activated Dialing	126
Calling by Name	126
Calling by Phone Number	126
Selecting Voice Dial Settings	127
Recording Voice	127
2I. Using Application Programs	129
Pocket Internet Explorer	130
The Mobile Favorites Folder	130
Favorite Links	130
Mobile Favorites	130
Using AvantGo Channels	132
Using Pocket Internet Explorer	132
Inbox: Sending and Receiving Email Messages	134
Synchronizing Email Messages	134
Connecting Directly to an Email Server	134
Using the Message List	135
Composing Messages	137
Managing Email Messages and Folders	137
MSN Messenger	139
Setting Up	139
Working With Contacts	140
Chatting With Contacts	141
Pocket Word	142
Typing Mode	143
Writing Mode	144
Drawing Mode	145
Recording Mode	145
Pocket Excel	146
Tips for Working in Pocket Excel	147
Windows Media Player for Pocket PC	148
Microsoft Reader	149
Getting Books on Your Device	149
Using the Library	149
Reading a Book	150
Using Reader Features	151

Removing a Book	152
Camera	153
Review/Share	155
Thumbnail View	155
Expand View	156
Share Menu	156
Options Menu	156
View Menu	157
Online Pictures	157
Thumbnail View	157
Expand View	158
Share Menu	159
Options Menu	159
ClearVue	160
Viewing a File	160
World Clock	162
SaiSuke	163
Installing Application Programs from the Companion CD	164
2J. Getting Connected	165
Sending Files Using Infrared Rays	166
Sending and Receiving Data	166
Connecting to the Internet Using PCS Connection	167
Restoring the PCS Vision Connection	168
Disconnecting from the Internet Using PCS Connection	169
Connecting to the PCS e-Mail Server	169
Making PCS e-Mail Setting	169
Connecting to the PCS e-Mail Server	169
Connecting Directly to an Email Server	171
Get Help on Connecting	172
2K. Connecting with a Personal Computer	173
Using Microsoft ActiveSync	174
Installing ActiveSync on a Personal Computer	175
Connecting With a Personal Computer	176
2L. Backing Up Data	179
Backing Up Data Using a Personal Computer	180
Backing Up Data Using a Memory Card	182
SECTION 3: Using PCS Service Features	185
3A. PCS Service Features: The Basics	187
Using Voicemail	188

Setting Up Your Voicemail	188
Voicemail Notification	188
New Voicemail Message Alerts	189
Retrieving Your Voicemail Messages	189
Voicemail Options	190
Using Caller ID	192
Responding to Call Waiting	192
Three-Way Calling	193
Using Call Forwarding	194
3B. PCS Vision	195
PCS Business Connection Personal Edition	196
Web	197
Browsing the Web	197
Picture Mail	197
Taking Pictures	197
Viewing Pictures	197
Uploading Pictures to the Picture Mail Website	198
Sharing Pictures	199
Messaging	201
PCS Vision FAQs	201
3C. PCS Voice Command	203
Getting Started With PCS Voice Command	204
Creating Your Own Address Book	204
Making a Call With PCS Voice Command	205
Accessing Information Using PCS Voice Command	205
SECTION 4: Safety and Warranty Information	207
4A. Safety	209
Getting the Most Out of Your Reception	210
Maintaining Safe Use of and Access to Your Device	211
Caring for the Battery	214
Warning	215
Caution	217
Precautions for Use	219
Instructions for Daily Use	219
Acknowledging Special Precautions and the FCC Notice	220
Consumer Information on Wireless Phones	225
Hardware Specifications	244
Owner's Record	246
User Guide Proprietary Notice	246

4B. Customer Limited Warranty	247
Customer Limited Warranty	248
Index	253

Welcome to Sprint

Sprint built the largest all-PCS nationwide network with advanced multimedia services and clear calls, reaching more than 230 million people for clarity you can see and hear. We built our network to give you what we believe you really want from a wireless phone: clear sound, private conversations and time-saving features.

But with Sprint, you can do something even more far-reaching – simplify your life. Our advanced technology is designed to grow with your communications needs so that one day you'll be able to rely entirely on your PCS Phone to stay connected.

This guide will familiarize you with our technology and with your new PCS Phone through simple, easy-to-follow instructions. If you have already reviewed the Start Here Guide, which was packaged with your new device, then you're ready to explore the advanced features outlined in this guide.

If you have not read your Start Here Guide, go to Section One – Getting Started. This section provides all the information you need to quickly activate your phone, set up your voicemail, and much more. It also contains information on how to contact Sprint should you have questions about service, want to purchase additional products or services, or just to check your account balance.

Thank you for choosing Sprint.

Introduction to This Online User's Guide

This online User's Guide introduces you to PCS Service and all the features of your new device. It's divided into four sections:

- ▶ **Section 1:** Getting Started
- ▶ **Section 2:** Understanding Your Device
- ▶ **Section 3:** Using PCS Service Features
- ▶ **Section 4:** Safety Guidelines and Warranty Information

Throughout the guide, you'll find tips that highlight special shortcuts and timely reminders to help you make the most of your new device and service. The Table of Contents and Index will help you locate specific information quickly.

You'll get the most out of your device if you read each section. However, if you'd like to get right to a specific feature, simply turn to that page. Follow the instructions in that section and you'll be ready to use your device in no time.

Tip: You can print out this guide to keep on hand or view it online.

Section 1

Getting Started

Section 1A

Setting Up Service

In This Section

- ▶ **Getting Started With PCS Service**
 - ▶ **Setting Up Your Voicemail**
 - ▶ **Getting Help**
-

This section walks you through the basics of setting up service for the phone on your device, including unlocking and activating your phone, setting up your voicemail, and how to contact Sprint for assistance with your PCS Service.

Getting Started With PCS Service

Determine if Your Phone is Already Activated

If you received your device in the mail or purchased it at a Sprint Store, the phone probably has been activated. If your phone is not activated, please refer to the Start Here Guide included with your device.



Activating Your Phone

To activate your phone, follow the directions in the Start Here Guide that was included with your device.

Setting Up Your Voicemail

All unanswered calls to your PCS Phone are automatically transferred to voicemail, even if your phone is in use or turned off. Therefore, you will want to set up your voicemail and personal greeting as soon as your PCS Phone is activated.

To set up voicemail:

1. Make sure the phone is on. See “Turning the Phone ON and OFF” on page 72 for details.
2. If the dialer screen is not displayed, activate the dialer screen by pressing  on the device.
3. From the dialer screen, tap and hold  for two seconds.
4. Follow the system prompts to create your pass code, record your greeting, record your name announcement, and choose whether to activate One-Touch Message Access (a feature that lets you press one key to access messages and bypasses the need for you to enter your pass code).

Note: The voicemail setup process may vary in certain Affiliate areas.

Getting Help

Visit Our Website

Stop by www.sprintpcs.com and log on to get up-to-date information on PCS Service, options, and more.

You can also:

- ▶ Review coverage maps
- ▶ Learn how to use voicemail
- ▶ Access your account information
- ▶ Purchase accessories
- ▶ Add additional options to your service plan
- ▶ Check out frequently asked questions
- ▶ And more

PCS Customer Solutions

PCS Customer Solutions is available to assist you 24 hours a day, seven days a week. Visit us at www.sprintpcs.com by signing on and clicking on Help Center.

Receiving Automated Invoicing Information

For your convenience, your phone gives you access to invoicing information on your PCS Account. This information includes balance due, payment received, invoicing cycle, and the amount of minutes and/or data used since your last invoicing cycle. (A nominal fee and/or airtime charges may apply.)

To access this information:

■ Tap   .

Note: This service may not be available in all Affiliate markets.

PCS Directory Assistance

PCS Directory Assistance provides a variety of services, including residential, business and government listings; assistance with local or long-distance calls; movie listings; and hotel, restaurant, shopping, and major local event information. There is a per-call charge and you will be billed for airtime.

■ Tap    .

PCS Operator Services

PCS Operator Services can provide assistance in placing collect calls or calls billed to a local telephone calling card or a third party.

■ Tap  .

For more information or to see the latest in products and services, visit us online at www.sprintpcs.com.

Note: PCS Operator Services may not be available in all Affiliate markets.

Section 2

Understanding Your Device

Section 2A

Your PCS Phone – The Basics

In This Section

- ▶ **Your PCS Phone's Features**
 - ▶ **Using the Batteries**
 - ▶ **Resetting**
 - ▶ **Initialization**
 - ▶ **Turning Your Device ON and OFF**
 - ▶ **LEDs**
 - ▶ **USB Cradle**
 - ▶ **Using the USB Port**
 - ▶ **Using the Infrared Communications Port**
 - ▶ **Using SD Card / MultiMediaCard**
 - ▶ **Using the Optional Headset**
 - ▶ **Camera**
 - ▶ **Jog Wheel**
 - ▶ **Talk Button**
 - ▶ **End Button**
 - ▶ **Speaker Phone Button**
 - ▶ **Voice Button**
 - ▶ **Volume Button**
 - ▶ **Key Guard Switch**
 - ▶ **Environment Switch**
 - ▶ **Using the Keyboard**
 - ▶ **Adjusting the Screen Brightness**
 - ▶ **Using the Stylus**
 - ▶ **Initial Setup**
 - ▶ **Provisioning**
 - ▶ **Today Screen**
 - ▶ **Navigation Bar and Command Bar**
 - ▶ **Programs**
 - ▶ **Pop-up Menus**
 - ▶ **Notifications**
 - ▶ **Entering Information on Your Device**
 - ▶ **Entering Text Using the Input Panel**
 - ▶ **Finding and Organizing Information**
-

This section will guide you through the basics of your device, and you'll be on your way to using it in no time.

Your PCS Phone's Features

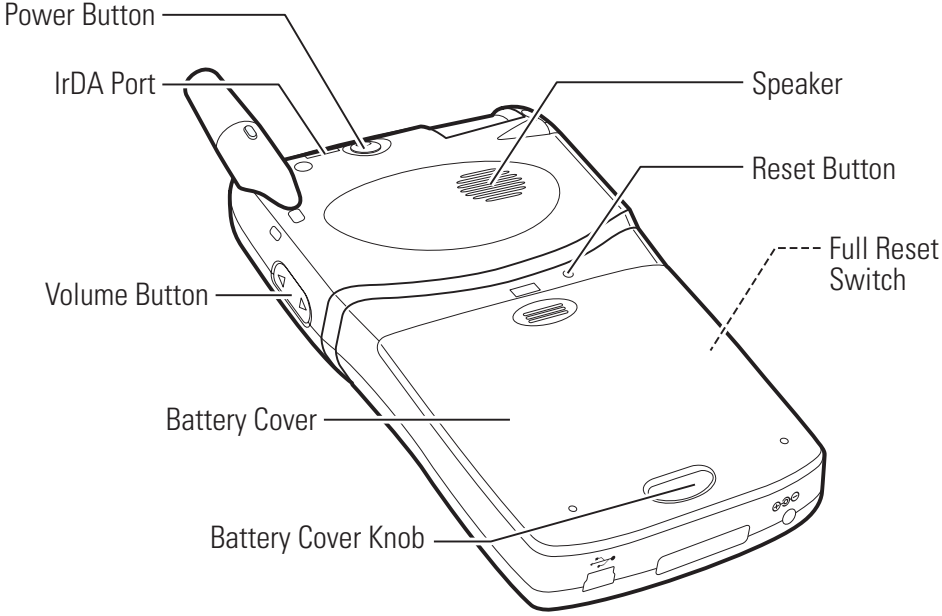
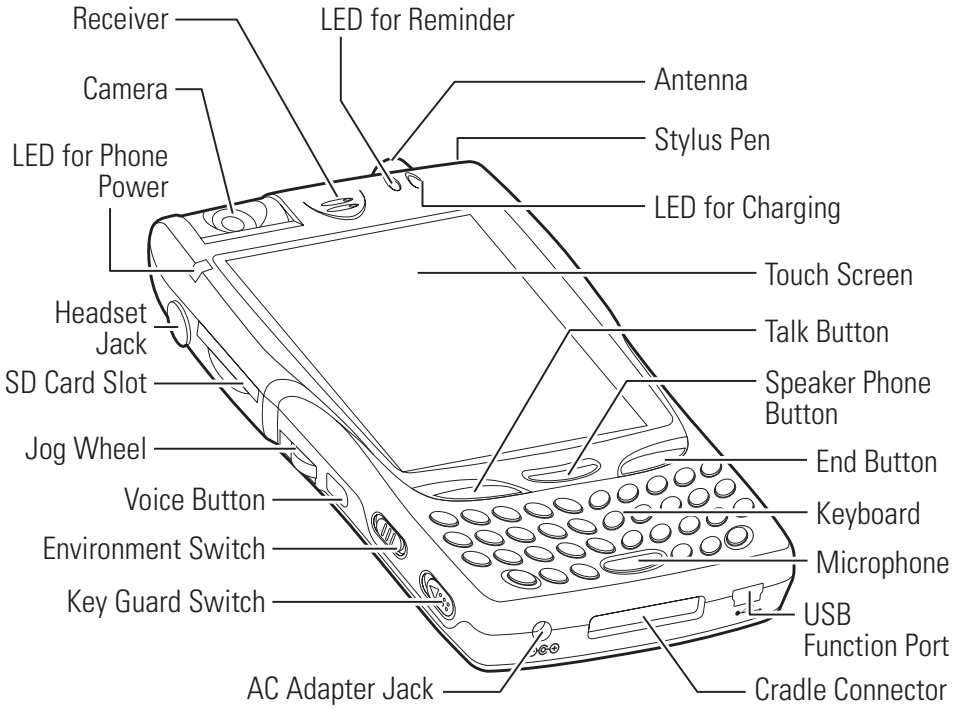

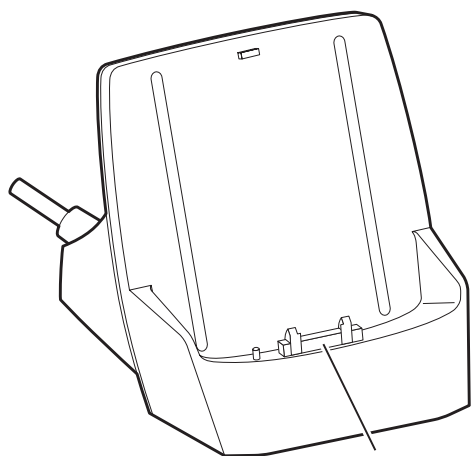

Connector

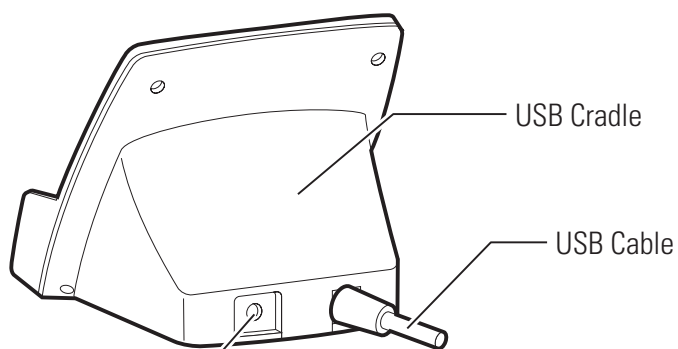

USB Cradle

USB Cable

AC Adapter Jack

Using the Batteries

This device uses two types of batteries; one is the main Lithium Ion (LiIon) battery and the other is the backup battery that holds data when the main battery is replaced. Because the device is shipped with neither of the batteries charged, make sure to charge the batteries before starting to use the device. The backup battery, which has been built into the device, is automatically charged through the main battery or the AC adapter.

The main battery will be referred to in this guide as just the battery.

Installing the Main Battery

Use the following procedure to install the supplied main battery:

1. While holding down the battery cover (A), slide it forward while pressing the release button (B).

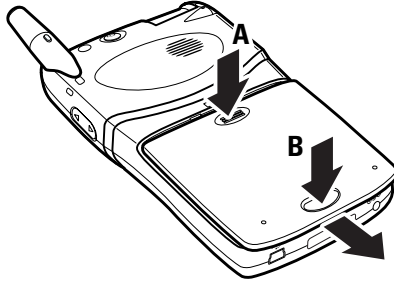

2. Slide the battery cover until the cover comes out of the guides, and then lift and remove the cover.

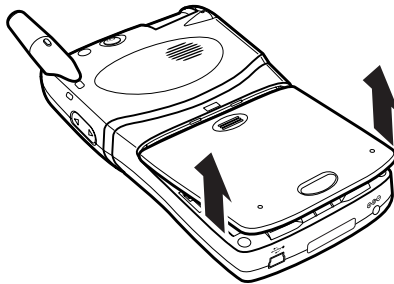

3. Hold the main battery with the label surface facing upward, and then install the battery so that the grooves at both sides mate.

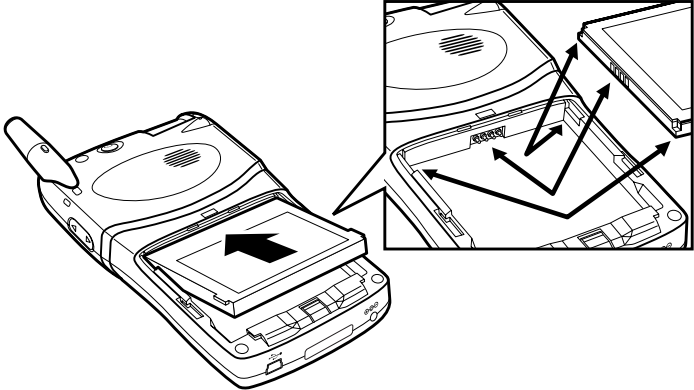

4. Using the stylus, shift the Full Reset switch upward to unlock it. (The switch is locked before the device is shipped.)

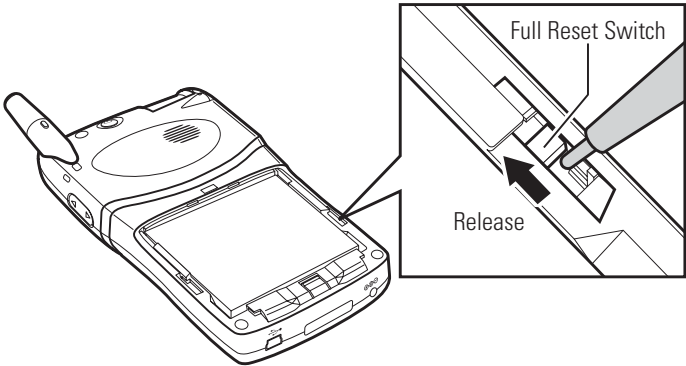

5. Replace the battery cover on the device.

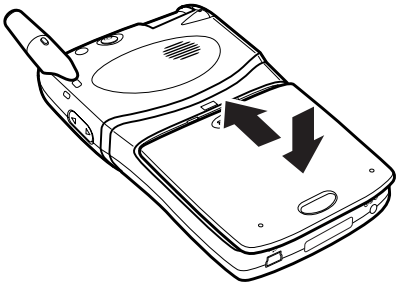

Removing the Main Battery

Use the following procedure to remove the main battery:

1. Confirm that the following backup battery power warning has not been displayed on the Power screen under Settings. If the warning has been displayed, charge the backup battery until the warning disappears.

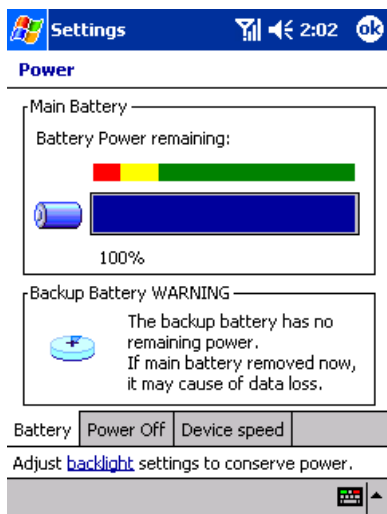

2. Press the Power button to turn the device off.
3. While holding down the battery cover (A), slide it forward while pressing the release button (B).

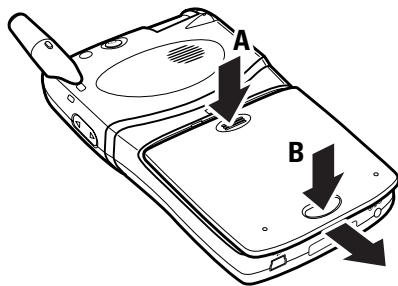

4. Slide the battery cover until the cover comes out of the guides, and then lift and remove the cover.

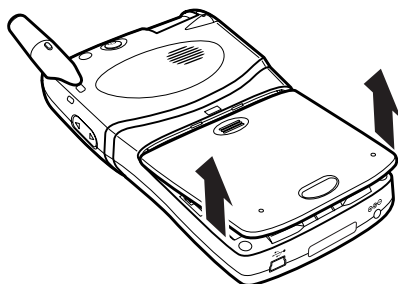

5. Hold both sides of the battery, and then lift and remove the battery.

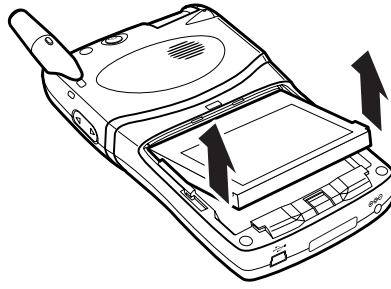

Note: If the battery is removed with the device on, data will be lost.

Note: If the main battery is removed when the backup battery is empty, data on the device will be lost.

Note: If the device is left with the main battery removed for more than five minutes, data on the device can be lost.

Tip: When the battery cover is removed from the device, the phone function is turned off.

To turn the phone function back on, ensure the battery cover is firmly slid into place and please do the following:

- Press and hold the Power button for at least 2 seconds.

- or -

- Tap phone antenna icon located at the top of the screen. A window will popup. Tap **Turn phone on**.

Phone function is now turned on.

Charging the Battery

Use one of the following two methods for charging the battery:

- Connect the supplied AC adapter and cradle as shown below, and then attach the device onto the cradle. For information on using the cradle, see “USB Cradle” on page 30.

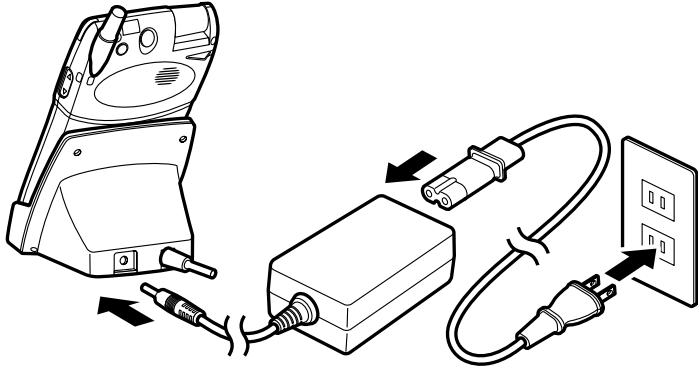

- or -

- Connect the supplied AC adapter to the device as shown below.

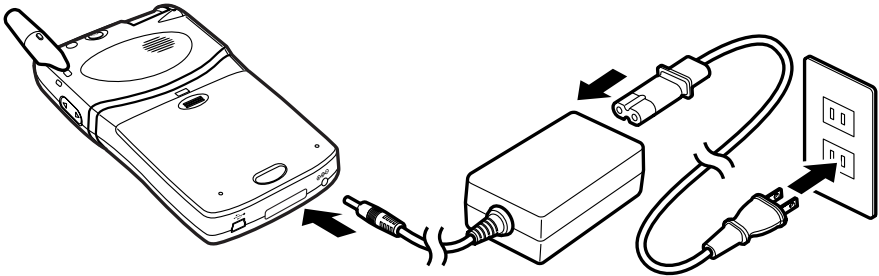

The LED for Charging lights amber while charging is being performed. The LED turns green when charging is completed. For more information about the LED for Charging, see “LEDs” on page 29.

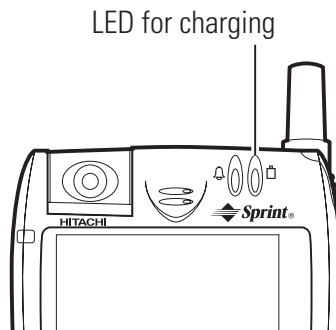

It takes approximately three hours to finish charging a battery that has only enough power for data backup, but not enough for operation.

Note: Charge the battery at an ambient temperature in the range from 0°C to 35°C (32°F to 95°F). Depending on the operating conditions of the device, charging may be interrupted even when the ambient temperature is lower than 35°C (95°F).

Note: If the ambient temperature becomes too high during charging, the Charging LED lights red and charging is interrupted. Charging is automatically restarted when the ambient temperature becomes appropriate.

Note: The battery may not be properly charged at low temperatures (less than 0°C/32°F) in winter. If this is the case, charge the battery in a warm room.

Note: If the device is used as it is just after purchase or after the device is left without being charged for an extended period of time, the remaining battery power may not be correctly indicated. Before using the device, be sure to charge the battery until the LED for Charging turns green.

Note: When the device has been connected with the AC adapter or placed on the cradle, incoming calls do not cause vibration, even with vibration on.

Note: As the battery nears a full charge, the LED for charging may turn green and orange alternately.

Battery Life

The main battery has a limited service life. Repeated charging and discharging of the battery will result in a gradual decrease in the charging capacity of the battery. If a fully recharged battery operates the device for a much shorter period than before, this indicates the end of battery life. When battery life is over, replace the battery with a new one.

The life of the main battery can vary, depending on how the device is used and ambient temperatures.

Tip: Unlike NiCad and Nickel Metal Hydride batteries, charging the main Lilon battery with some amount of power remaining hardly reduces the maximum allowable operating time.

Note: Do not use the device at too high a temperature. The battery life will become shorter than when used at normal temperatures.

Note: For safe disposal options of your Lithium Ion batteries, contact your nearest Sprint-authorized service center.

Note: Be sure to dispose of your battery properly. In some areas, the disposal of batteries in household or business trash may be prohibited.

Battery Operating Time

The main battery allows approximately 2.5 hours of continuous talk time, approximately seven days of continuous standby time, or approximately 12 hours of continuous PDA operation time.

Note: The maximum continuous talk time, standby time, and PDA operation time are affected by backlight settings, service searching, vibrate mode, game use, and browser use.

Note: The maximum battery operating time varies, depending on how the device is stored and on ambient temperatures. Charging or using the battery at low temperatures (less than 0°C/32°F) can cause a significant reduction in the maximum operating time because of the characteristics of a Lithium Ion battery. The standard maximum operating time is restored when placed under room temperature conditions (25°C/77°F).

Extending the Maximum Battery Operating Time

You can use the following methods to extend the maximum operating time of the main battery:

- ▶ Decrease the screen brightness. For the setting method, see “Adjusting the Screen Brightness” on page 44.
- ▶ Set the device so that screen brightness is automatically lowered when the main battery is consumed. For the setting method, see “Selecting Backlight Settings” on page 97.
- ▶ Place the device into the power saving (low speed) mode. For the setting method, see “Adjusting Power Settings” on page 100.
- ▶ Set the device so that the LED does not blink when the alarm is set. For the setting method, see “Selecting Sounds & Notifications Settings” on page 96.
- ▶ Switch off the sound function that produces various sounds, including beeps generated at the time of key entry and tapping. For the setting method, see “Selecting Sounds & Notifications Settings” on page 96.

Tip: When connecting to a personal computer, use the AC adapter to conserve Lilon battery strength.

Data Backup Time

When both the main battery and the backup battery are completely discharged, data stored in the device will be lost. Immediately after the battery icon indicates the low level or a warning message appears, connect the AC adapter to charge the battery.

- ▶ Data will be kept for approximately five days after the main battery is discharged to such an extent that the device cannot be switched on.
- ▶ The main battery and the backup battery discharge slowly even when they are not used. The batteries will be completely discharged when they are not used for an extended period of time.
- ▶ It is strongly recommended that you save the device's data on a personal computer or a memory card. For the method of backing up data, see "Backing Up Data" on page 179.

Note: When the device is left with a USB cable or a card connected, the backup time may be reduced. When not using the device, remove peripheral equipment from the device.

Note: If the device is left with the battery discharged for an extended period of time, the battery life may be shortened. Recharge the battery every three months, even not when using the device for a long period of time.

Resetting

Use the stylus to push the Reset button when the device freezes during operations or when the device prompts you to do so at the time of software installation.

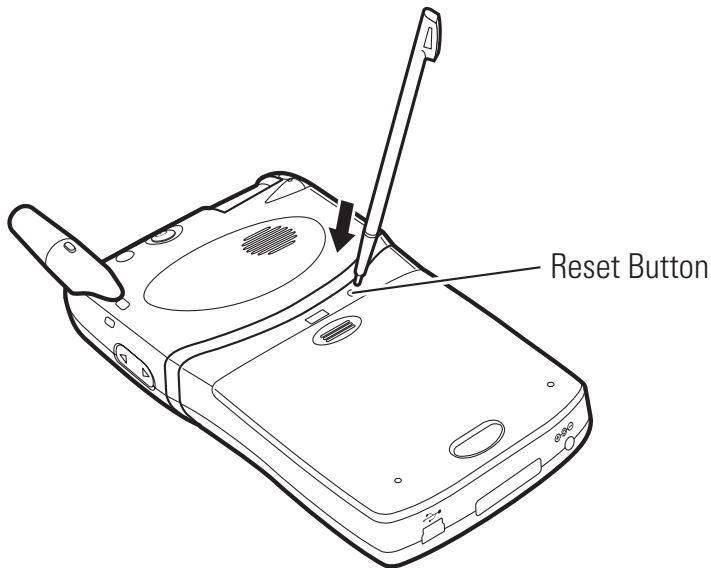

Note: Resetting the device causes data not yet saved to be lost. Data that has been saved will not be lost through this operation.

Tip: If resetting the device does not allow it to restore the normal status, perform initialization. Note, however, that initialization will cause all data saved in the device's memory to be erased. For details, see "Initialization" on page 26.

Note: When the screen freezes do not remove the battery. Press the Reset button. Removing the battery may cause data to be lost.

Initialization

Perform initialization only when pushing the Reset button does not allow the device to be restarted.

Note: Initialization will cause all data saved in the device's memory to be erased. The programs preinstalled before shipment will not be erased.

Before performing initialization, back up important data using a personal computer or a memory card. For details about data backup, see “Backing Up Data” on page 179.

Note: Remove a memory card before starting initialization.

1. Remove the AC adapter and peripheral equipment from the device. Executing initialization with equipment connected may result in initialization failure.
2. Remove the main battery. To remove, see “Removing the Main Battery” on page 18.
3. Using a non-conductive fine tool, shift the Full Reset switch downward (lock position). The power is switched off.

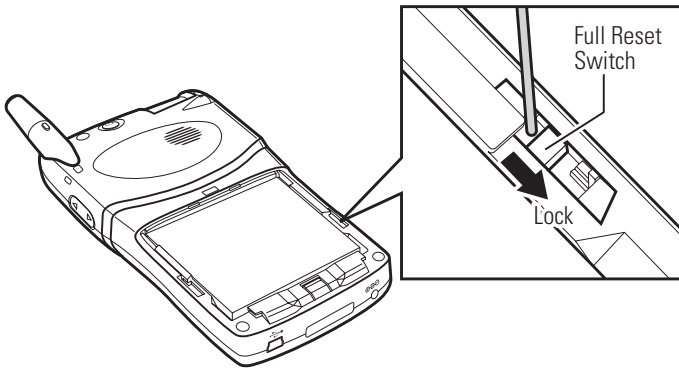

4. Wait for approximately two minutes.
5. Install the main battery. To install, see “Installing the Main Battery” on page 16.

6. Using the stylus, shift the Full Reset switch upward (unlock position).
The memory will be initialized, and the device is restarted.

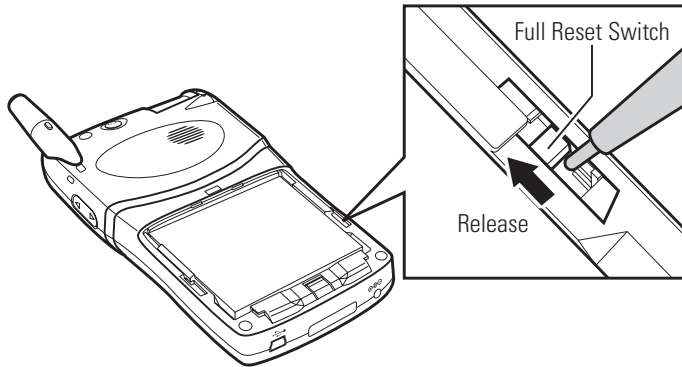

7. Replace the battery cover on the device.
8. Connect the AC adapter to the device.
9. Set up the device. See “Initial Setup” on page 45.

Turning Your Device ON and OFF

Turning the Device On and Off

Each time you press the Power button, the device is switched on and off.

Tip: You cannot operate the Power button when:

- ▶ The main battery has no power left.
 - ▶ The Key Guard switch is on.
 - ▶ The Full Reset switch has been locked.
-

Turning the Phone On and Off

Each time you press and hold the Power button or the End button for two seconds, the phone is switched on and off.

When the phone is on, the LED for Phone Power blinks. For more information about LED for Phone Power, see “LEDs” on page 29.

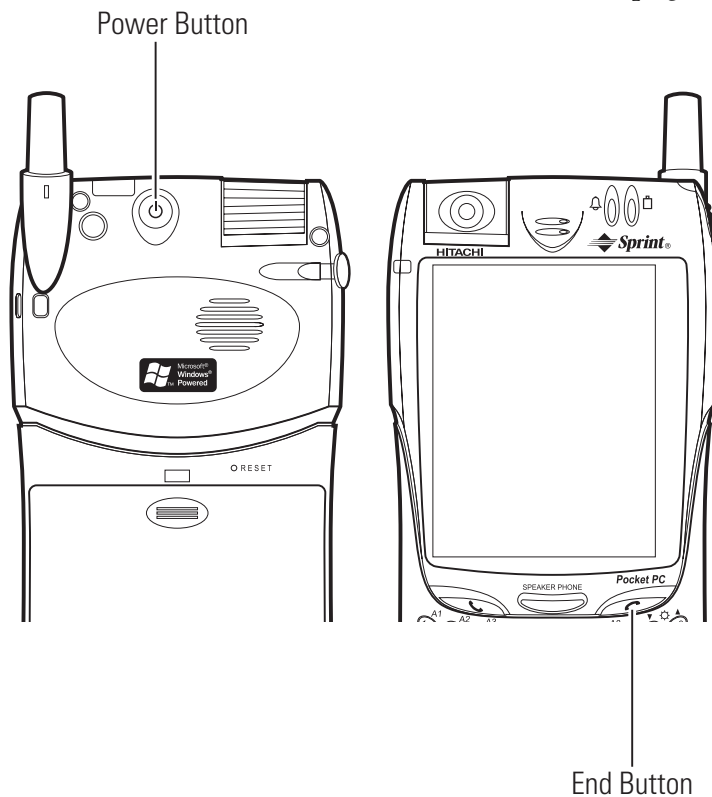

LEDs

This device is equipped with three status LEDs.

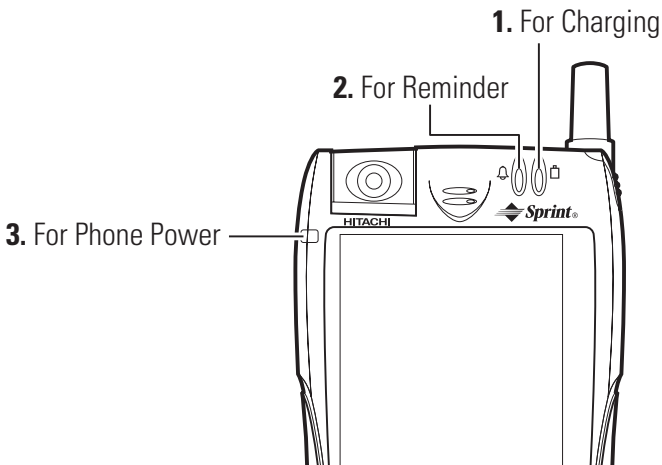

1. LED For Charging

- ▶ Steady amber: Charging in progress
- ▶ Steady green: Charging completed
- ▶ Steady red: Charging stopped (because of high ambient temperature)

2. LED For Reminder

- ▶ Flashes orange: Alarm for the programmed plan and job

3. LED For Phone power

Flashes green at various intervals as below when the phone is on.

- ▶ In Service: Blinks at intervals of five seconds (with a shorter On time period)

Flashes at this interval when service is available; this is not true of active MIP data connections mentioned below. The statuses where this happens include idle, voice call, and inactive data connections.

- ▶ Active Data Service: Blinks at intervals of 0.5 second

Flashes at this interval when an active MIP data connection is established. The flashing status for in-service is restored when data connection becomes inactive.

- ▶ No Service: Blinks at intervals of five seconds (with a longer On time period).

Flashes at this interval when the phone is out of any service range.

- ▶ Deep Sleep: Blinks at intervals of three minutes.

Flashes at this interval when the phone is out of any service range for 15 minutes.

USB Cradle

Your PCS Phone comes with a USB cradle.

Use the supplied USB cradle to charge the battery or to exchange data with a connected personal computer.

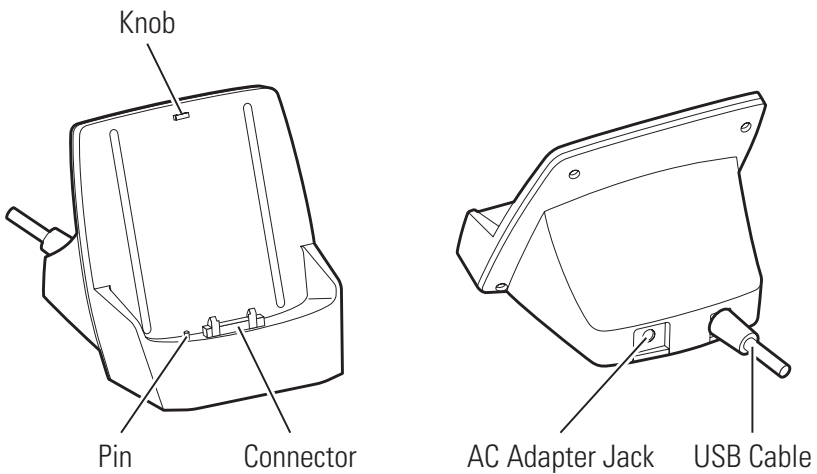

Mounting the Device onto the USB Cradle

1. Insert the bottom of the device onto the mating connector and pin on the USB cradle.

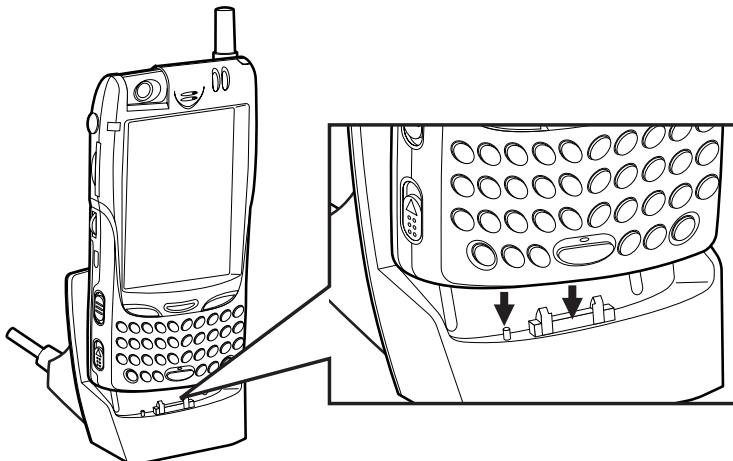

2. Tilt the device in the direction of the arrow so that its tab hole is aligned with the tab on the cradle.

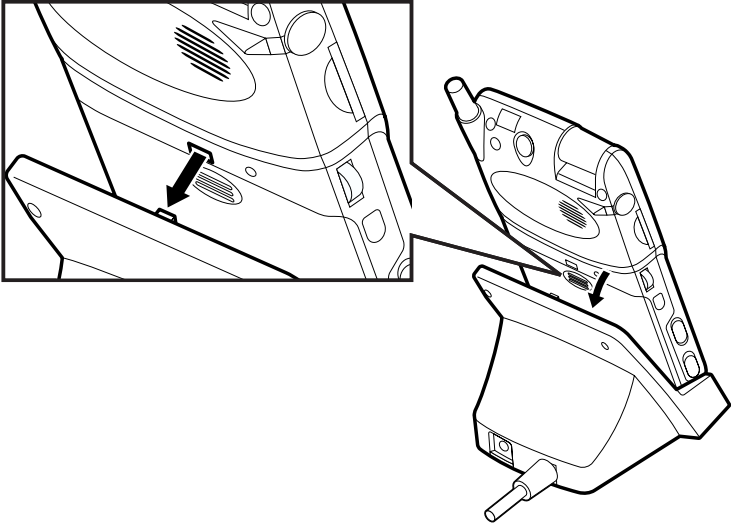

Removing the Device from the USB Cradle

■ Pull the device forward, and then remove it from the USB cradle.

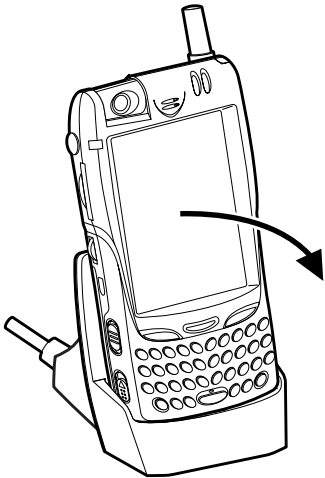

Note: After the device has been mounted onto the USB cradle, the vibrating device (if switched on) does not function when a call is received.

Using the USB Port

Using the USB allows you to easily connect the device to a personal computer in order to exchange data. Use one of the following two connecting methods:

- Connect one appropriate end of a USB cable to the device, and the other appropriate end to the USB port on the personal computer.

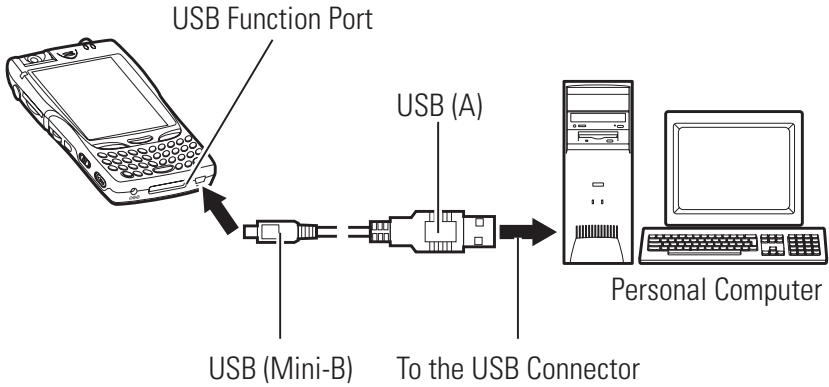

- or -

- Connect the cable of the supplied USB cradle to the USB port on the personal computer, and then mount the device onto the USB cradle. To use the USB cradle, see “USB Cradle” on page 30.

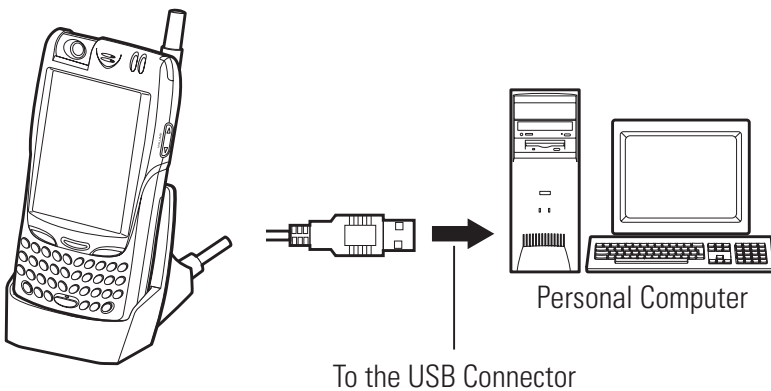

Using the Infrared Communications Port

This device also has an IrDA port for communicating with another compatible device. When using the IrDA port, position the two devices so that the respective IrDA ports face each other. In addition, there should be no obstacles between the two devices.

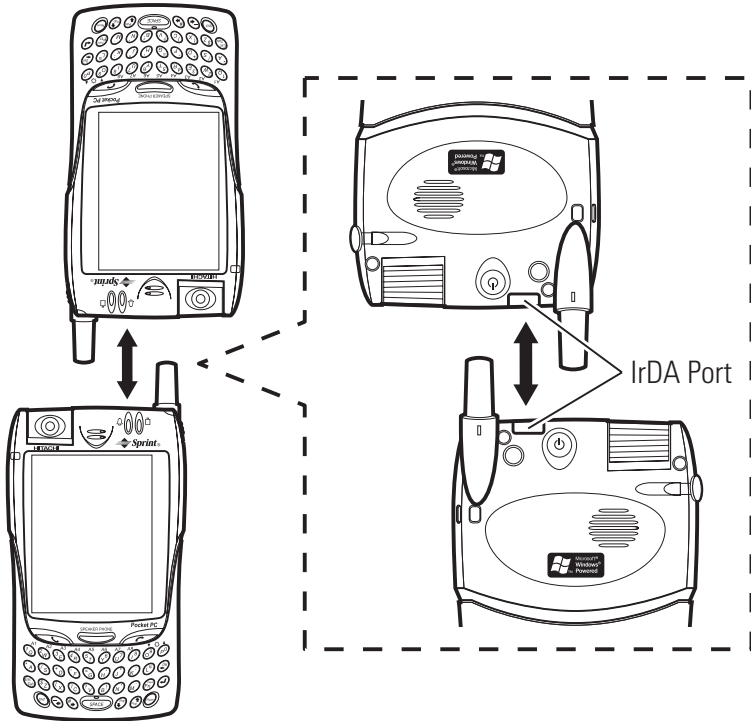

Be careful that the IrDA ports line up within 15 degrees in the horizontal and vertical directions and that the distance between the two devices is less than 70 cm (27.5 inches).

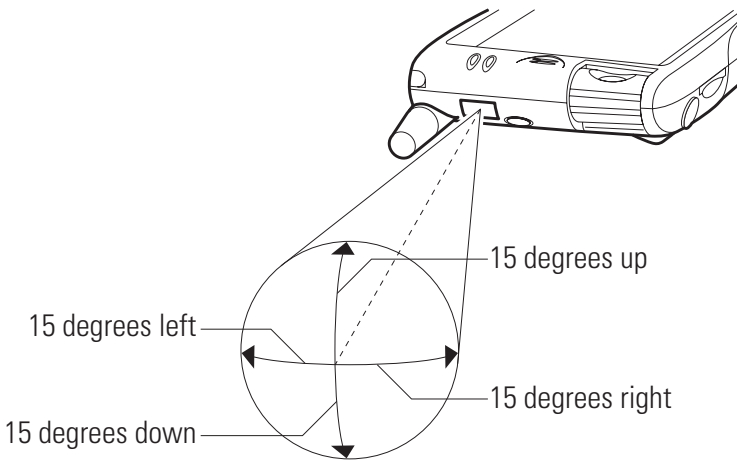

Using SD Card / MultiMediaCard

This device can be used with a commercially available SD card or MultiMediaCard.

1. Remove the card slot protector from the SD card slot.

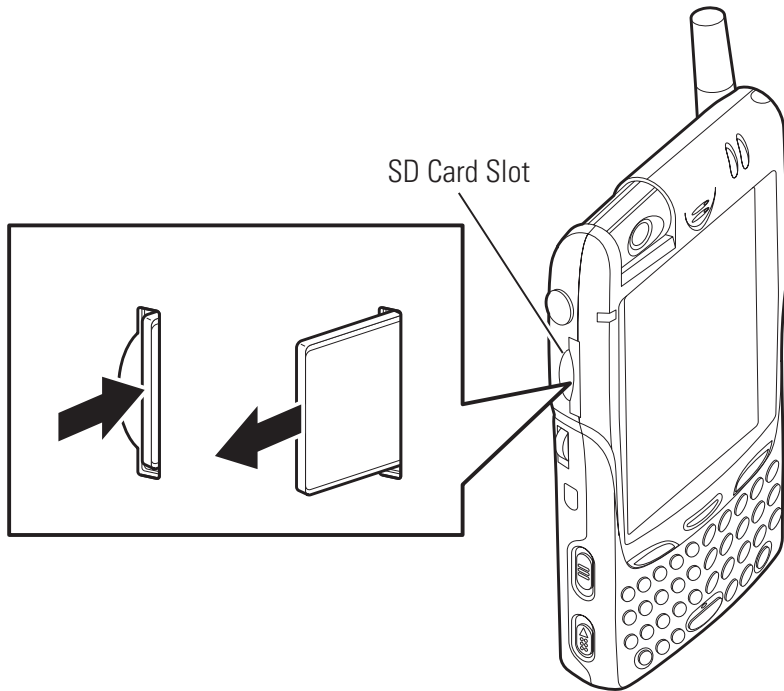

- ▶ Push the card slot protector until it clicks, and then release your finger to cause the protector to be ejected. Slowly pull the ejected protector out of the slot.

2. Hold the card so that its top surface and the touch screen face the same direction, and then insert the card into the SD card slot. Push the card until it clicks.

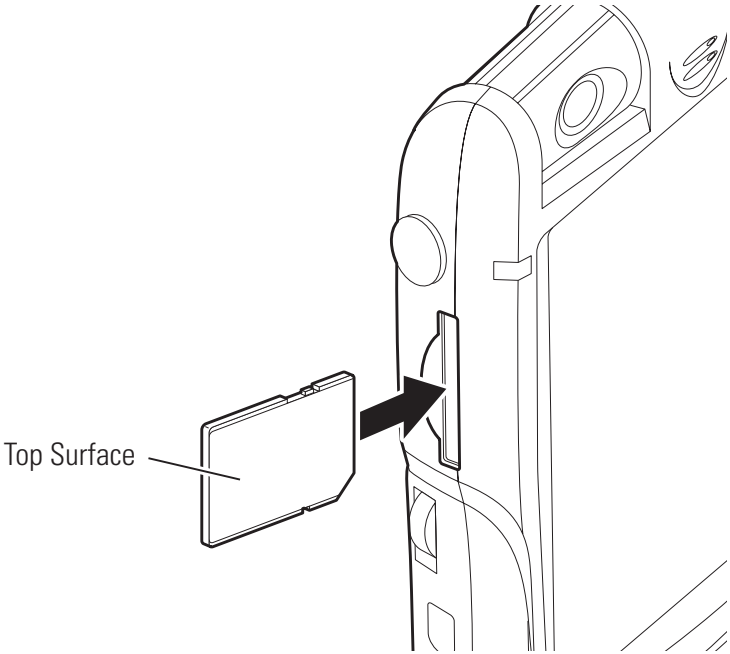

To remove the card, follow the instructions in step 1.

Note: This device does not support the SD card security function.

Note: If you insert a card incorrectly and push it with a strong force, both the card and the card slot can be damaged.

Note: When releasing your finger after pushing the card, the card may jump out of the slot. Do not place your face close to the slot.

Note: Do not try to force the card out of the card slot with your fingernails.

Note: When not using a card, make sure to replace the card slot protector.

Tip: This device supports a Secure MultiMediaCard.

Using the Optional Headset

- To connect an optional headset to this device, insert the plug on the headset into the headset jack on the device.

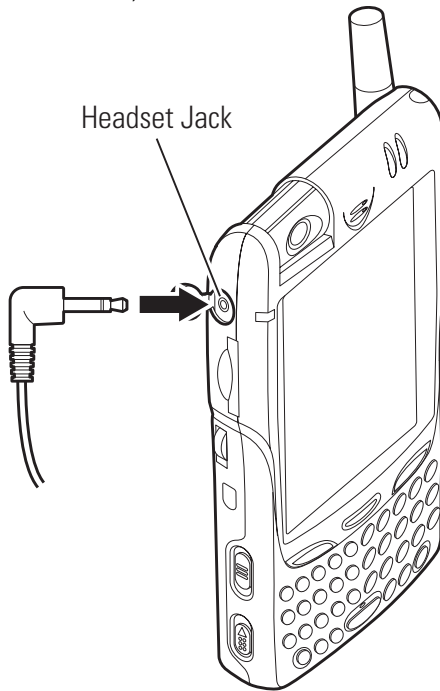

Note: Insert the headset plug into the jack as far as it goes. Incomplete connection of the headset plug can result in abnormal sounds.

Note: When using headphones with a 3.5 mm (1/8 inches) stereo phone plug, use the supplied stereo mini plug adapter. You must not use an adapter other than the supplied one.

Note: When using the headset or headphones, be careful not to increase the volume too much.

Note: Audio volume differs depending on data to be played back. If the volume control has been set to the maximum level, unexpected excessive volume may damage your ears. Before playing back data, set the volume control to the minimum level, and then gradually increase the volume to the appropriate level.

Camera

This device incorporates a VGA camera to capture still images.

You can rotate the camera forward and backward 180 degrees. When the camera is fully rotated forward, captured images are displayed upside down. For details about operations, see “Camera” on page 153.

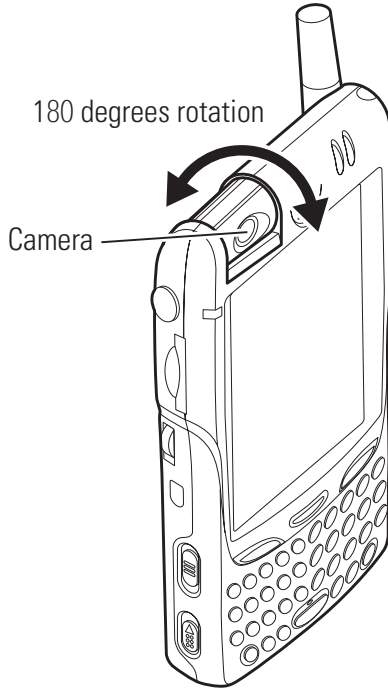

Note: If the lens is dirtied with fingerprints, oil, or grease, clean it with a soft cloth before taking pictures.

Note: Even though the camera is produced with very high precision technologies, some pixels may always appear bright and some pixels may always appear dark. This is not a malfunction.

Note: If pictures are taken after the device has been in a warm location for an extended period of time, image quality may be lowered.

Note: Do not expose the lens to direct sunlight for a long period of time. This may cause the internal color filter to be discolored.

Note: Do not attempt to rotate the lens beyond the allowable range.

Note: Make sure to hold the device firmly so that captured images will not be blurred.

Jog Wheel

Use the jog wheel to select and execute an application or a pull-down menu item.

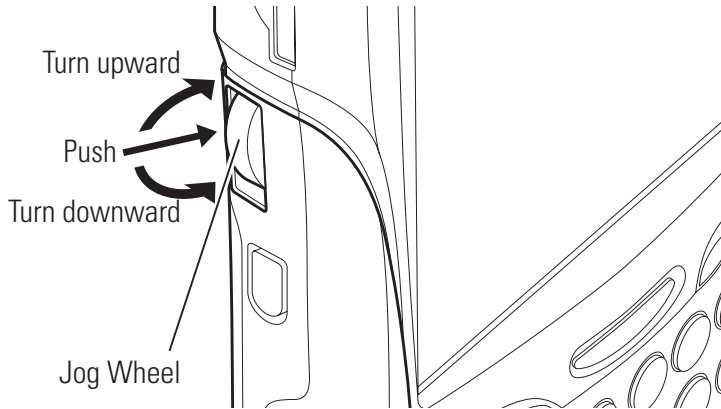

- ▶ **Upward turn:** Moves the cursor upward
- ▶ **Downward turn:** Moves the cursor downward
- ▶ **Push:** Executes the item selected using the cursor

Talk Button

Use the Talk button to make a phone call or answer an incoming call. You can also use it to activate the phone application.

For details about operations, see “Keypad Operation List” on page 68.

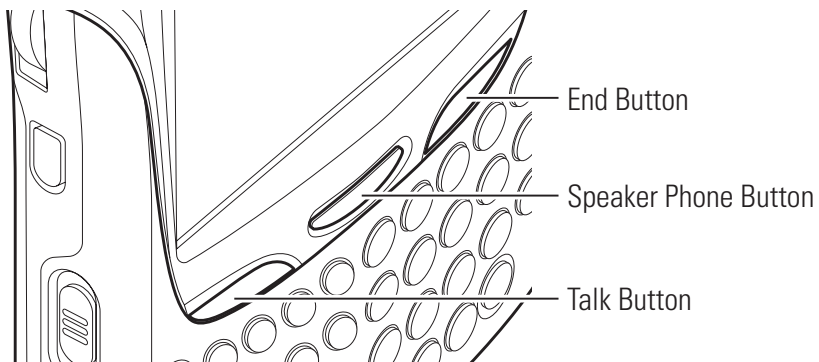

End Button

Use the End button to switch off the ringer volume or to finish a conversation.

For details about operations, see “Keypad Operation List” on page 68.

Speaker Phone Button

Use the Speaker Phone button to enable the speaker phone or to activate the voice dial function (for details, see “Using Voice-Activated Dialing” on page 126).

The Speaker Phone button provides different functions, depending on the current status.

The following functions are available when the phone function is on:

Status	Press to
The dialer is being executed without a phone number entered	Activate the voice dial function and switch the speaker phone on
The dialer is being executed with a phone number entered	Call the entered telephone number and switch the speaker phone on
A function other than the dialer is being executed	Activate the voice dial function and switch the speaker phone on
A call is being received	Answer the incoming call and switch the speaker phone on
During conversation	Switch to speaker phone

Note: When the conversation is ended, the speaker phone will automatically be switched off.

Voice Button

Use the Voice button to activate the voice dial and voice memo functions. For details about the voice dial function, see “Making a Call From Voice Dial” on page 76. For details about the voice memo function, see “Recording a Message” on page 62.

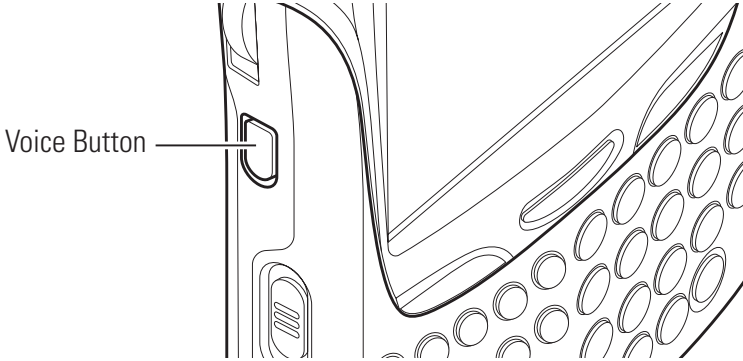

The Voice button provides the different functions, depending on the current status.

Status	Press to	Press and hold to
Waiting for a call (with the device switched on)	Activate Voice Dial	Activate Voice Memo
During conversation	—	Activate Voice Memo

Volume Button

Use the Volume button to adjust the device’s sound volume.

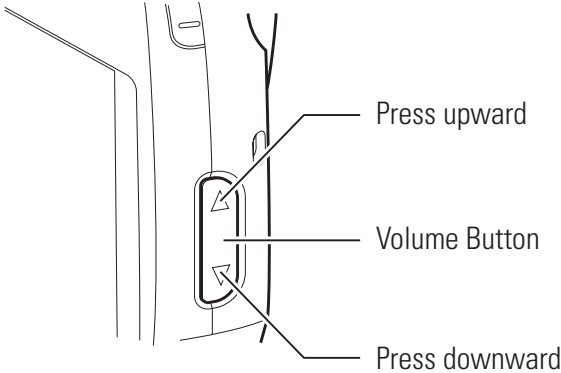

- ▶ **Upward press:** Increases the volume
- ▶ **Downward press:** Decreases the volume

Note: When the Environment switch is set for “Silent,” the volume will be switched off regardless of the operation of the Volume button. For details about the Environment switch, see “Environment Switch” on page 42.

Key Guard Switch

Use the Key Guard switch to prevent unintentional operations. This button is also convenient when using functions (such as music playback) that do not need the screen.

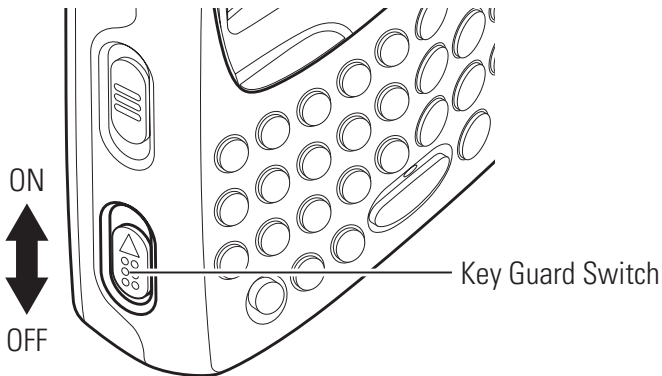

Turning on the Key Guard switch (up position) places the device into the following status:

- ▶ Screen: Off
- ▶ The Power button, touch panel, keyboard, jog wheel, and Voice button will be disabled.

Note: Even when the Key Guard switch is on, the LEDs, Talk button, End button, Speaker Phone button, Environment switch, Volume button, Reset button, and Full Reset switch are still available.

Environment Switch

Use the Environment switch to change the volume and type of ringer tones.

You can set the mode simply by putting the switch in the top, middle, or bottom positions, providing a quick and easy way to select modes suited to various places and situations.

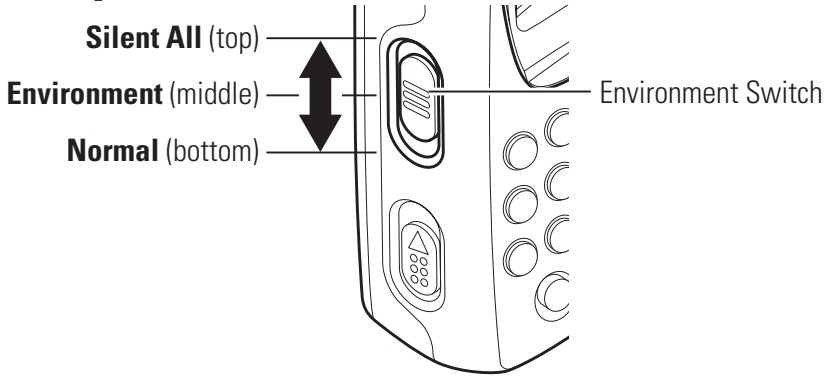

- ▶ The mode names for the three switch positions are **Silent All** (top), **Environment** (middle), and **Normal** (bottom).
- ▶ Slide the switch up or down to switch modes. Silent All or names of the Environment modes appear on the Today Screen (See “Today Screen” on page 47).
- ▶ You can select **Meeting**, **Outdoor**, **Office**, and **Private** within the Environment mode. See “Changing the Environment Mode and Volume and Ring Type/Tone Settings for Individual Modes” on page 82.
- ▶ When in the Environment mode, the ringer tone volume and type selected under “Environment” (page 82) will be used.
- ▶ If the volume or ring type setting is changed when in the Environment mode, the new setting is valid until another mode is selected.
- ▶ When in the Silent All mode, “Off” is always selected for the volume. This is true no matter if the volume is changed through “Sound & Notification” under “Settings” (page 96), or if the ringer type/tone is changed though “Phone” under “Settings” (page 80).

Using the Keyboard

The keyboard allows you to enter text. This section describes the basic operations for entering text using the keyboard.

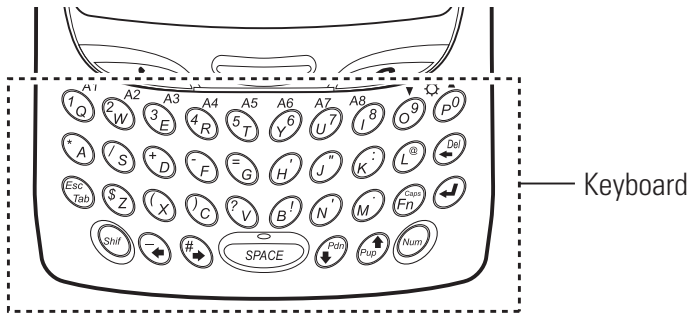

- ▶ To enter characters (small letters) or codes printed on the keys in black, simply press the corresponding keys.
- ▶ To enter characters (capital letters) or codes printed on the keys in black, press and hold the Shift key, and then press the corresponding keys.
- ▶ To switch Caps Lock on and off, press and hold the Shift key, and then press the Fn (Caps) key.
- ▶ To switch Num Lock on and off, press and hold the Shift key, and then press the Num key.

Note: With Caps Lock on, pressing a key with an alphabetic character causes the corresponding capital letter to be entered. With Caps Lock on, pressing a key with an alphabetic character while pressing the Shift key causes the corresponding small letter to be entered.



- ▶ To enter numeric characters and codes printed on the keys in purple, press and hold the Num key, and then press the corresponding keys.
- ▶ To enter A1 to A8 or printed in bluish green, press and hold the Fn key, and then press the corresponding keys. When A1 to A8 are entered, the applications registered under these keys are started. For the registration method, see “Setting Buttons” on page 94. For , see “Adjusting the Screen Brightness” on page 44.

- ▶ The Shift, Fn, and Num keys also function as sticky keys. When one of these keys is pressed, this function causes the key to remain active until another key is pressed. This function is useful when pressing two keys at the same time is difficult.

Note: You can also enter text using the Input panel. For the method of using the Input panel, see “Entering Text Using the Input Panel” on page 54.

Adjusting the Screen Brightness

You can adjust the screen brightness, depending on the ambient brightness and other ambient conditions.

- To adjust the screen brightness, press and hold the Fn key, and then press  (brighter) or  (dimmer).

Note: You can select the screen brightness from five levels. You can also set the screen brightness to automatically decrease when no entry is made through the screen or keyboard for a certain period of time. For more information, see “Selecting Backlight Settings” on page 97.

Using the Stylus

Use the stylus to select menu items or enter data on the touch screen.

The methods for using the stylus are as follows:

- ▶ **Tap:** Touch the screen once with the stylus to select items such as menus, icons, and buttons on the screen.
- ▶ **Tap and hold:** Keep touching the screen with the stylus. When an icon or item is tapped and held, a red circular mark appears, followed by a pop-up menu.
- ▶ **Drag:** Hold the stylus on the screen and move it to shift icons or other items on the screen, to enter text by handwriting, or to draw pictures.

Note: Use only the supplied stylus to operate the touch screen. When using the stylus, gently touch the screen with it.

Initial Setup

When the device is switched on for the first time after purchase or after the device is initialized, the following screen appears. Perform initial setup procedures according to the on-screen instructions.

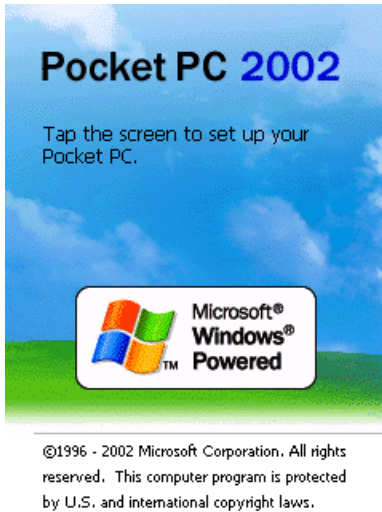

1. Tap anywhere on the screen.
2. The Align screen appears for touch screen alignment.
 - ▶ Tap the center of the cross marker. Each time you tap the center of the marker, the marker moves. When the center of the marker is tapped five times, the alignment is completed and the Stylus screen appears.
3. Read the descriptions of the methods for using the stylus, then tap **Next**. The screen for practicing pop-up menu operations appears.
4. Following the instructions, open a pop-up menu and perform cut-and-paste operations. After finishing the paste operation, tap **Next**. The Location screen appears.
5. Specify a location on the Location screen.
 - ▶ Tapping  (shown to the right of the Time zone box) causes a list to be displayed. As necessary, change the time zone where the device is to be used and then tap **Next**. The Complete screen appears.
6. Tap the Complete screen. The Today screen appears and the device is ready for use.

7. If the phone of the device has not been activated, switch the phone on to start the Activation Wizard.



8. Following the Activation Wizard, enter your activation code (also known as OTKSL), phone number (also known as MDN), and the MSID assigned to you by your PCS Customer Solutions Specialist.

Provisioning

In order to perform data communications, you need to perform the following operations first:

1. Tap , then **Settings**. On the **Personal** tab, tap **Phone**, then the **Data** tab on the bottom.
2. Tap **Update Data Profile**, then **Yes**.

Today Screen

You can display the Today screen by tapping  and then **Today**. On the Today screen, you can see at a glance important information for the day.

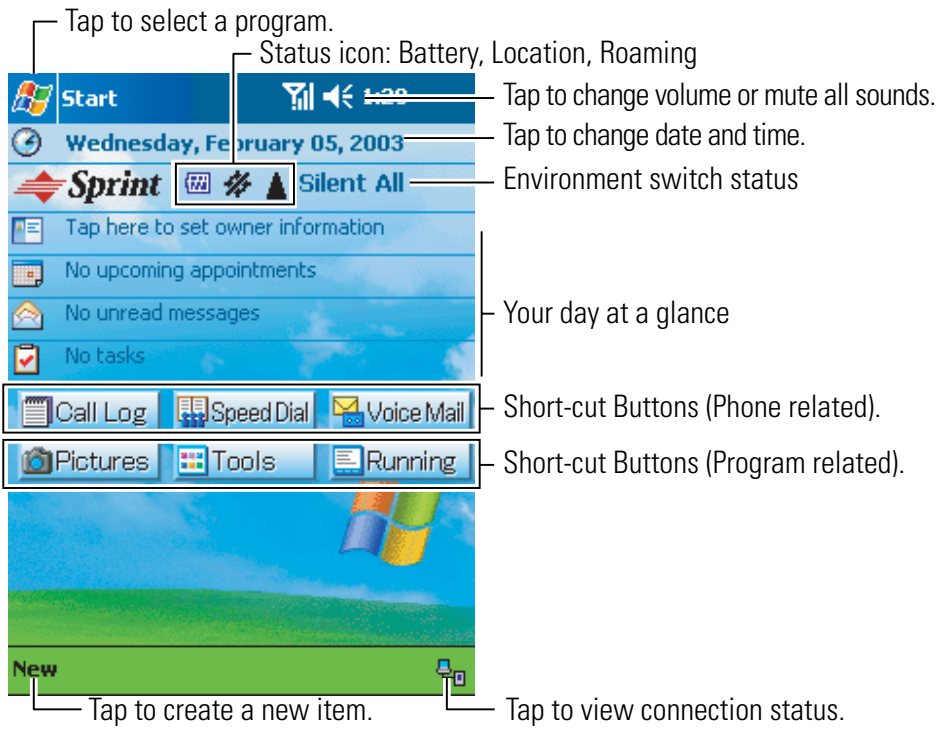

► Environment switch status

The current Environment switch mode is indicated with text. Mode types: “Silent All,” “Meeting,” “Outdoor,” “Office,” “Private.”

Note: No Environment indication is given with Normal mode selected.

For the Environment switch, see page 42.

► Short-cut buttons

Call Log button: Launches the Dialer Log screen

Speed Dial button: Launches the Dialer Speed Dial screen

Voice Mail button: Launches Voice Mail

Pictures button: Launches the picture-related program start screen







Tools button: Launches the tool-related program start screen

Tip: To customize the programs registered on the tool-related program start screen, select the **Items** tab on **Settings** under **Today**, and then select **Options** under **Prglaunch** to start a screen for customization.

Running button: Launches the running program start screen

▶ **Status icon**

Following are some of the status icons you may see:

Status Icon	Meaning
	Main batteries are full
	Main batteries are low (26–50%)
	Main batteries are low
	Main batteries are very low
	Location ON
	Location OFF
	Roaming ON



Navigation Bar and Command Bar



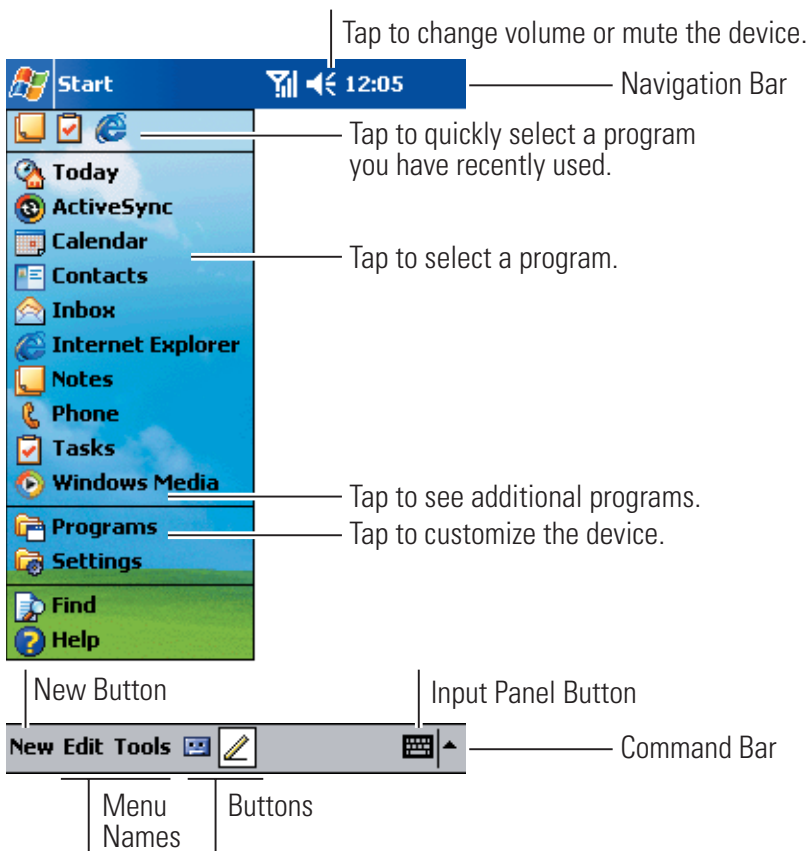











The navigation bar is located at the top of the screen. It displays the active program and current time, and allows you to switch to programs and close screens.

Use the command bar at the bottom of the screen to perform tasks in programs. The command bar includes menu names, buttons, and the Input Panel button. To create a new item in the current program, tap **New**. To see the name of a button, tap and hold the stylus on the button. Drag the stylus off the button if you do not wish to carry out the command.





The following icons will appear on the navigation bar:

	Phone is on, but is out of range of any signal.
	Phone is on, and is receiving a signal.
	Phone call is in progress. To quickly switch back to Phone from any other program, tap this icon.

	Phone is off. (Airplane mode)
	Sound ON
	Sound OFF
	Vibrate ON
	Battery power remaining Low status
	Battery power remaining Very Low status
	More than one status icon is in display
	Data connection is in progress
	Signing in with MSN Messenger is being executed
	Start and end processings of synchronization with a personal computer through ActiveSync
	Voice Message
	email/SMS
	Speaker Phone ON
	Emergency callback mode
	Missed call











Note: If more notification icons need to be displayed than there is room to display them, the Notification icon () will display. Tap the icon to view all active notification icons.



Programs

You can switch from one program to another by selecting it from the  menu. You can customize which programs you see on this menu (see “To add a program to the Start menu:” on page 93). To access some programs, you’ll need to tap , **Programs**, and then the program name.

You can also start programs using the launcher function on the Today screen. See “Today Screen” on page 47.

The following table contains a partial list of programs that are installed on your device:

Icon	Program	Description
	ActiveSync	Synchronize information between your device and computer
	Calendar	Keep track of your appointments and create meeting requests
	Contacts	Keep track of your friends and colleagues
	Inbox	Send and receive email/SMS messages
	Pocket Internet Explorer	Browse Web and WAP sites and download new programs and files from the Internet
	Notes	Create handwritten or typed notes, drawings, and recordings
	Tasks	Keep track of your tasks
	Pocket Excel	Create new workbooks or view and edit Excel workbooks created on your computer
	MSN Messenger	Send and receive instant messages with your MSN Messenger contacts
	Pocket Word	Create new documents or view and edit Word documents created on your desktop computer

Icon	Program	Description
	Phone	Make and receive calls
	Microsoft Reader	Read e-books
	Windows Media Player	Play back Windows Media Audio (.wma) files, MP3 (.mp3) files, and Windows Media Video (.wmv) files
	Solitaire	Play a card game
	File Explorer	Manage files
	Camera	Take pictures using the built-in camera
	Review/Share	Display and edit JPEG images
	Data Backup	Back up your device files to an SD card
	Calculator	Perform calculations
	ClearVue Document	Display Microsoft Word files created on your computer
	ClearVue Worksheet	Display Microsoft Excel files created on your computer
	ClearVue Presentation	Display Microsoft PowerPoint files created on your computer
	ClearVue PDF	Display Adobe Portable Document Format (PDF) files created on your computer

Pop-up Menus

With pop-up menus, you can quickly choose an action for an item. For example, you can use the pop-up menu in the contact list to quickly delete a contact, make a copy of a contact, or send an email message to a contact. The actions in the pop-up menu vary from program to program. To access a pop-up menu, tap and hold the stylus on the item name that you want to perform the action on. When the menu appears, lift the stylus and tap the action you want to perform. Tap anywhere outside the menu to close the menu without performing an action.

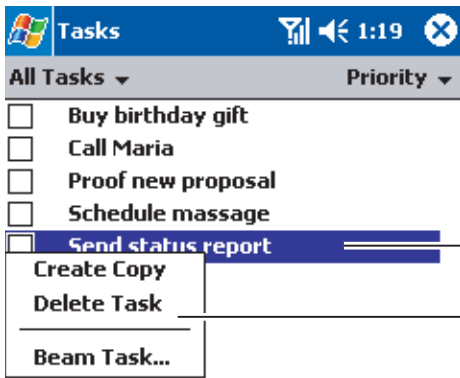

Tap and hold to display the pop-up menu.

Lift the stylus and tap the action you want.

Tap outside the menu to close it without performing an action.

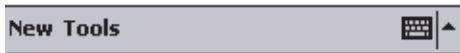

Notifications

Your device reminds you in a variety of ways when you have something to do. For example, if you've set up an appointment in Calendar, a task with a due date in Tasks, or an alarm in Clock, you'll be notified in any of the following ways:

- ▶ A message box appears on the screen.
- ▶ A sound (which you can specify) is played.
- ▶ A light flashes on your device.
- ▶ The device vibrates.

- To choose reminder types and sounds for your device, tap  and then **Settings**. In the **Personal** tab, tap **Sounds & Notifications**. The options you choose here apply throughout the device.

Entering Information on Your Device

You have several options for entering new information:

- ▶ Use the input panel to enter typed text, either by using the soft keyboard or other input method.
- ▶ Write directly on the screen.
- ▶ Draw pictures on the screen.
- ▶ Speak into your device microphone to record a message.
- ▶ Use Microsoft® ActiveSync® to synchronize or copy information from your computer to your device. For more information on ActiveSync, see ActiveSync Help on your computer.

Entering Text Using the Input Panel

Use the input panel to enter information in any program on your device. You can either type using the soft keyboard or write using Letter Recognizer, Block Recognizer, or Transcriber. In each case, the characters appear as typed text on the screen.

- To show or hide the input panel, tap the **Input Panel** button. Tap the arrow next to the **Input Panel** button to see your choices.

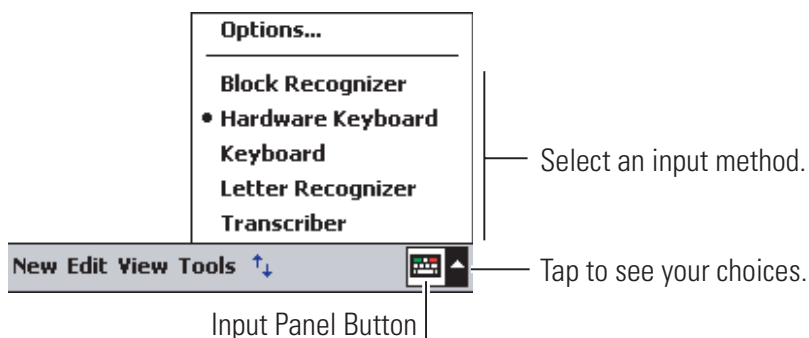

Note: You can also enter text using the keyboard. To use the keyboard, see “Using the Keyboard” on page 43.

When you use the input panel, your device anticipates the word you are typing or writing and displays it above the input panel. When you tap the displayed word, it is inserted into your text at the insertion point. The more you use your device, the more words it learns to anticipate.

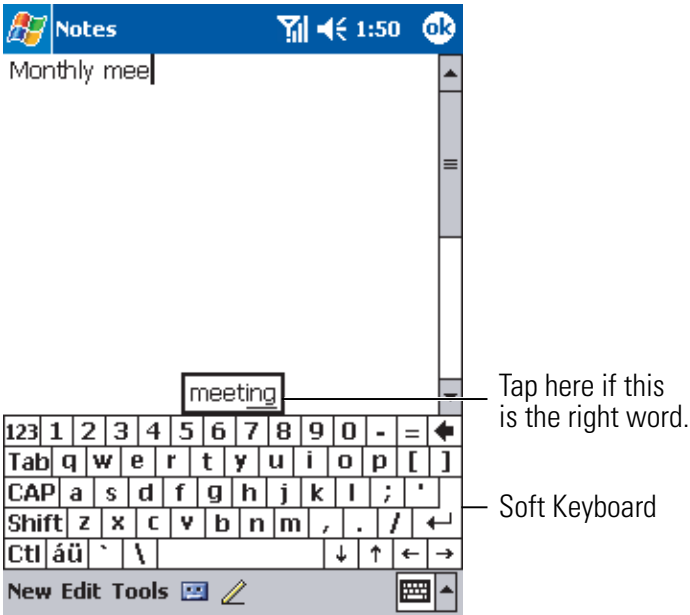

Note: To change word suggestion options, such as the number of words suggested at one time, tap , **Settings, Personal** tab, **Input**, and then the **Word Completion** tab.

To Type with the Keyboard:

- Tap the arrow next to the **Input Panel** button and then tap **Hardware Keyboard**. For more information, see “Using the Keyboard” on page 43.

To Type with the Soft Keyboard:

1. Tap the arrow next to the **Input Panel** button and then tap **Keyboard**.
2. On the soft keyboard that is displayed, tap the keys with your stylus to enter text.

To use Letter Recognizer:

With Letter Recognizer you can use the stylus to write letters just as you would write on paper.

1. Tap the arrow next to the **Input Panel** button and then tap **Letter Recognizer**.
2. Use the stylus to write a letter in the box.

When you write a letter, it is converted to typed text that appears on the screen. For specific instructions on using Letter Recognizer, open Letter Recognizer and tap the question mark next to the writing area.

To use Block Recognizer:

With Block Recognizer you can use the stylus to input character strokes that are similar to those used on other devices.

1. Tap the arrow next to the **Input Panel** button and then **Block Recognizer**.
2. Use the stylus to write a letter in the box.

When you write a letter, it is converted to typed text that appears on the screen. For specific instructions on using Block Recognizer, open Block Recognizer and tap the question mark next to the writing area.

To use Transcriber:

With Transcriber you can use the stylus to write anywhere on the screen just as you would on paper. Unlike Letter Recognizer and Block Recognizer, you can write a sentence or more with Transcriber. Then, pause and let Transcriber change the written characters to typed characters.

1. Tap the arrow next to the Input Panel button and then **Transcriber**.
2. Use the stylus to write anywhere on the screen.

For specific instructions on using Transcriber, open Transcriber and tap the question mark in the lower right hand corner of the screen.

To select typed text:

1. Drag the stylus across the text you want to select.
2. Format or edit text by tapping the command on the **Edit** menu or by tapping and holding the selected words until the pop-up menu appears.

Writing on the Screen

In any program that accepts writing, such as the Notes program, and in the **Notes** tab in Calendar, Contacts, and Tasks, you can use your stylus to write directly on the screen. Write the way you do on paper. You can edit and format what you've written and convert the information to text at a later time.

To write on the screen:

- Tap the **Pen** button to switch to writing mode. This action displays lines on the screen to help you write.

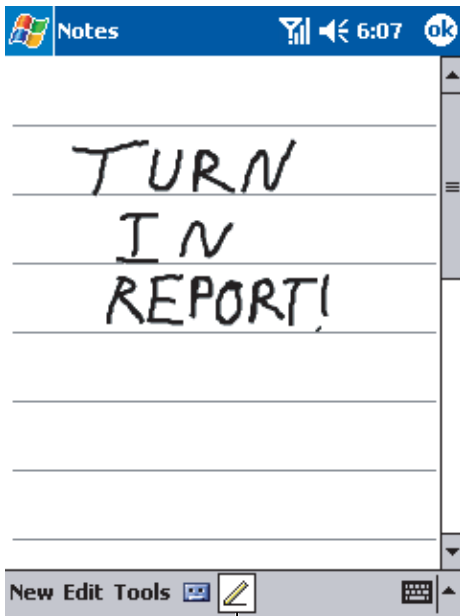

Tap the **Pen** button and use your stylus like a pen.

Note: Some programs that accept writing may not have the **Pen** button. See the documentation for that program to find out how to switch to writing mode.

To select writing:

If you want to edit or format writing, you must first select it.

1. Tap and hold the stylus next to the text you want to select until the insertion point appears.
 2. Without lifting, drag the stylus across the text you want to select.
- ▶ If you accidentally write on the screen, tap **Edit**, then **Undo** and try again. You can also select text by tapping the **Pen** button to deselect it and then dragging the stylus across the screen.

You can cut, copy, and paste written text in the same way you work with typed text: tap and hold the selected words and then tap an editing command on the pop-up menu, or tap the command on the **Edit** menu.

To convert writing to text:

- Tap **Tools** and then **Recognize**.

If you want to convert only certain words, select them before tapping **Recognize** on the **Tools** menu (or tap and hold the selected words and then tap **Recognize** on the pop-up menu). If a word is not recognized, it is left as writing.

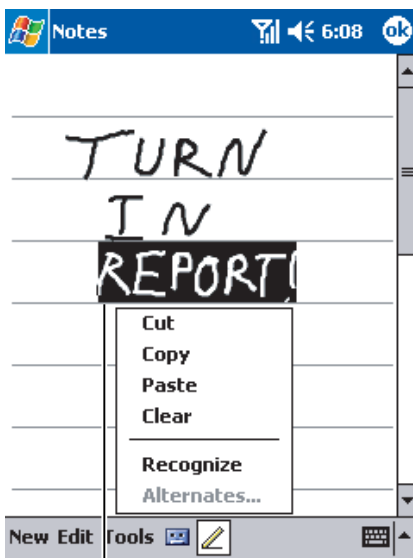

Select the text you want to convert and tap **Recognize** on the **Tools** pop-up menu.

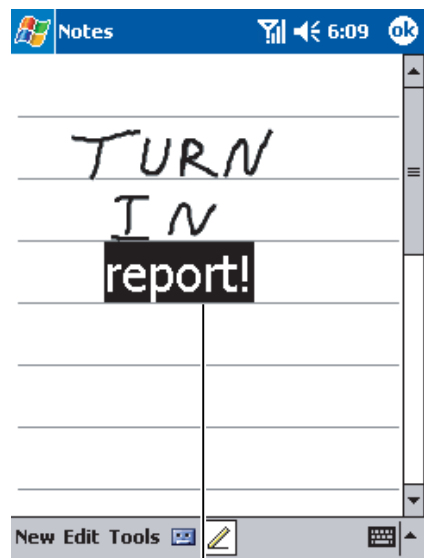

The writing is converted into text.

If the conversion is incorrect, you can select different words from a list of alternates or return to the original writing. To do so, tap and hold the incorrect word (tap one word at a time). On the pop-up menu, tap **Alternates**. A menu with a list of alternate words appears. Tap the word you want to use or tap the writing at the top of the menu to return to the original writing.

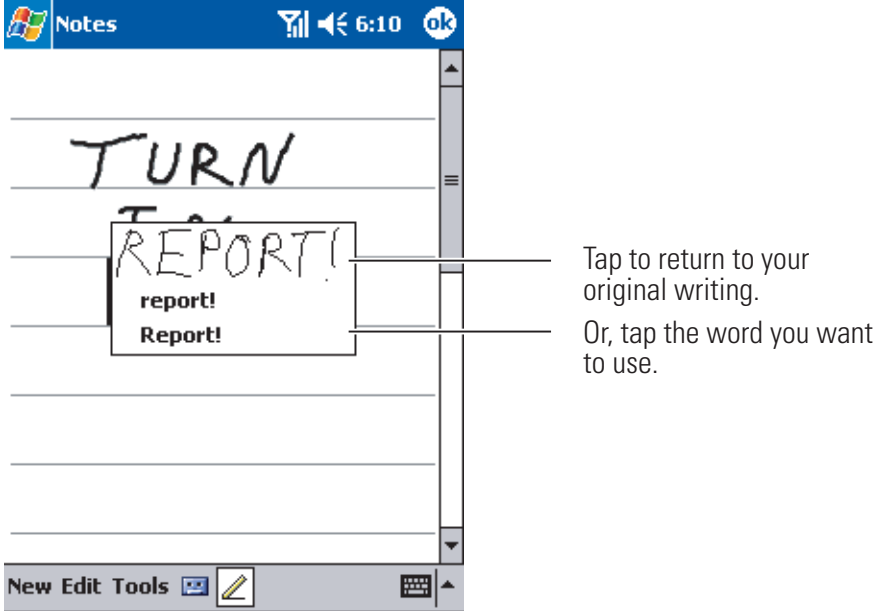

Tips for getting good recognition:

- ▶ Write neatly.
- ▶ Write on the lines and draw descenders (e.g., the lower part of “g”) below the line. Write the cross of the “t,” the dots of the “i” and “j,” and apostrophes below the top line so that they are not confused with the word above. Write periods and commas above the line.
- ▶ For better recognition, try increasing the zoom level to 300% using the **Tools** menu.
- ▶ Write the letters of a word closely and leave large gaps between words so that the device can easily tell where words begin and end.

Note: Hyphenated words, foreign words that use special characters such as accents, and some punctuation cannot be converted.

Note: If you add writing to a word to change it (such as changing a “3” to an “8”) after you attempt to recognize the word, the writing you add will not be included if you attempt to recognize the writing again.

Drawing on the Screen

You can use the stylus to draw on the screen in the same way that you write on the screen. The difference between writing and drawing on the screen is how you select items and how they can be edited. For example, selected drawings can be resized, while writing cannot.

To create a drawing:

- Cross three ruled lines on your first stroke. A drawing box appears. Subsequent strokes in or touching the drawing box become part of the drawing. Drawings that do not cross three ruled lines will be treated as writing.

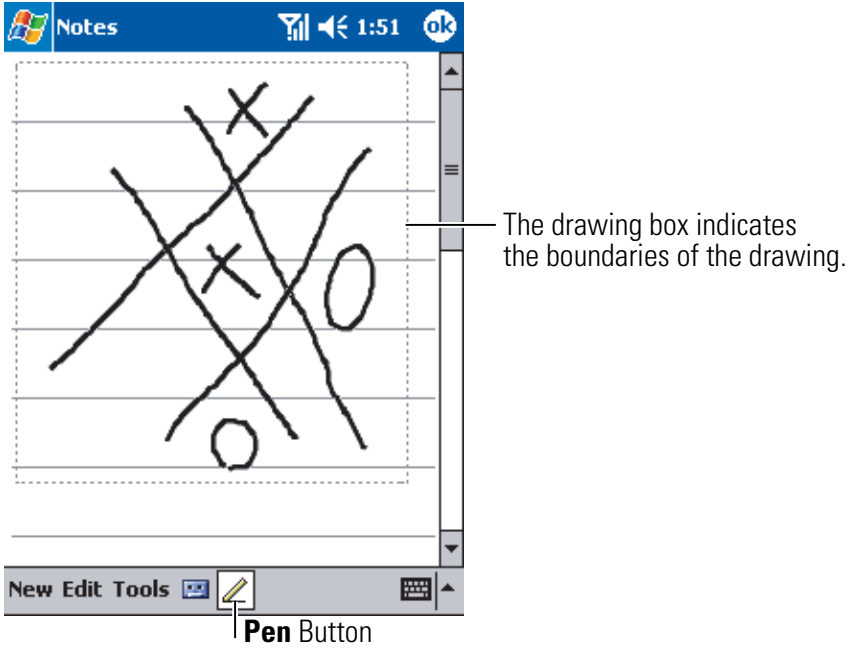

Note: You may want to change the zoom level so that you can more easily work on or view your drawing. Tap **Tools** and then tap a zoom level.

To select a drawing:

If you want to edit or format a drawing, you must first select it.



- Tap and hold the stylus on the drawing until the selection handle appears. To select multiple drawings, deselect the **Pen** button and then drag to select the drawings you want.

You can cut, copy, and paste selected drawings by tapping and holding the selected drawing and tapping an editing command on the pop-up menu, or by tapping a command on the **Edit** menu. To resize a drawing, make sure the Pen button is not selected, and drag a selection handle.

Recording a Message

In any program where you can write or draw on the screen, you can also quickly capture thoughts, reminders, and phone numbers by recording a message. In Calendar, Tasks, and Contacts, you can include a recording in the **Notes** tab. In the Notes program, you can either create a stand-alone recording or include a recording in a written note. If you want to include the recording in a note, open the note first. In the Inbox program, you can add a recording to an email message.

To create a recording:

1. Hold your device's microphone near your mouth (or other audio source).
2. Press and hold the Voice button on the right side of the device. The recording toolbar appears.
3. Tap the **Record** button () on the toolbar to start recording.
4. To stop recording, tap the **Stop** button () on the toolbar.

- To play a recording, tap it in the list or tap its icon in the note.

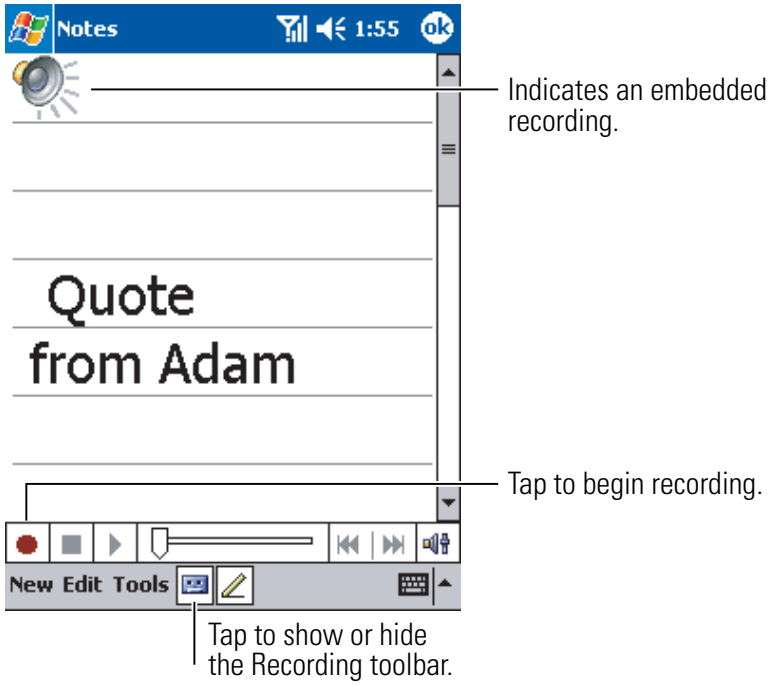

Using My Text

When using Inbox or MSN Messenger, use My Text to quickly insert preset or frequently used messages into the text entry area. To insert a message, tap **My Text** and tap a message.



You are chatting with: jun

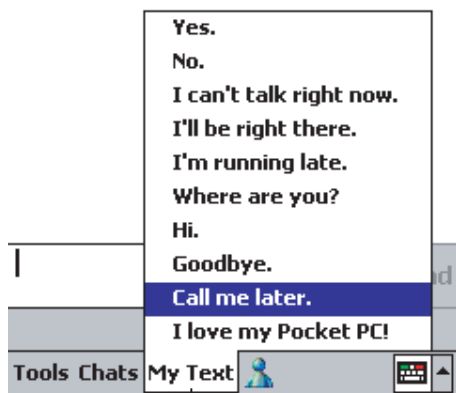

Tap to select a prewritten message.

Note: After inserting a My Text message, you can add text before sending the message.

- To edit a My Text message, open the **Tools** menu, tap **Edit My Text Messages**. Select the message you wish to edit and make desired changes.

Finding and Organizing Information

The Find feature on your device helps you quickly locate information.

- On the  menu, tap **Find**. Enter the text you want to find, select a data type, and then tap **Go** to start the search.

Note: To quickly find information that is taking up storage space on your device, select **Larger than 64 KB** in **Type**.

You can also use the File Explorer to find files on your device and to organize these files into folders. On the  menu, tap **Programs**, and then tap **File Explorer**.

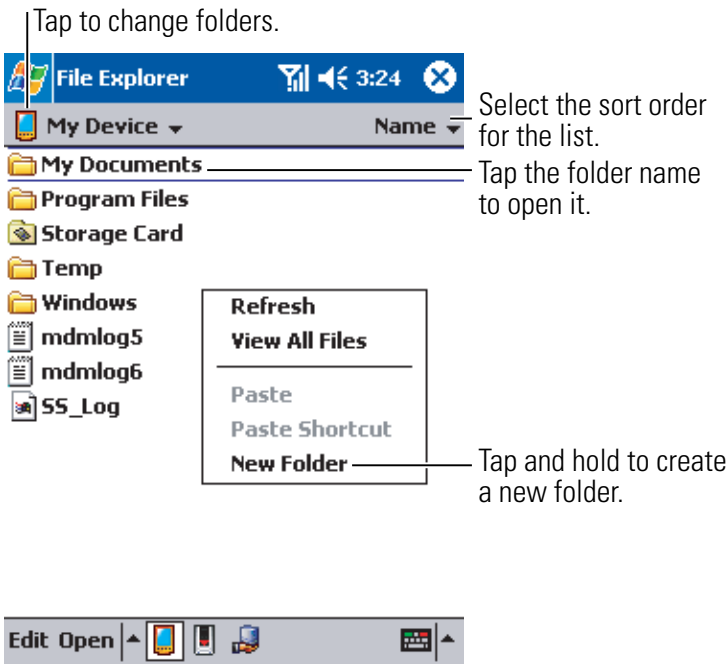

Note: You can move files in File Explorer by tapping and holding the item you want to move, and then tapping **Cut** or **Copy** and **Paste** on the pop-up menu.

Section 2B

Using Your Phone

In This Section

- ▶ **Viewing the Display Screen**
 - ▶ **Turning the Phone ON and OFF**
 - ▶ **Displaying Your Phone Number**
 - ▶ **Making and Answering Calls**
-

Your device is packed with features that simplify your life and expand your ability to stay connected to the people and information that are important to you. This section will guide you through the basics of your device's phone function. Follow these instructions and you'll be on your way to using your phone in no time.



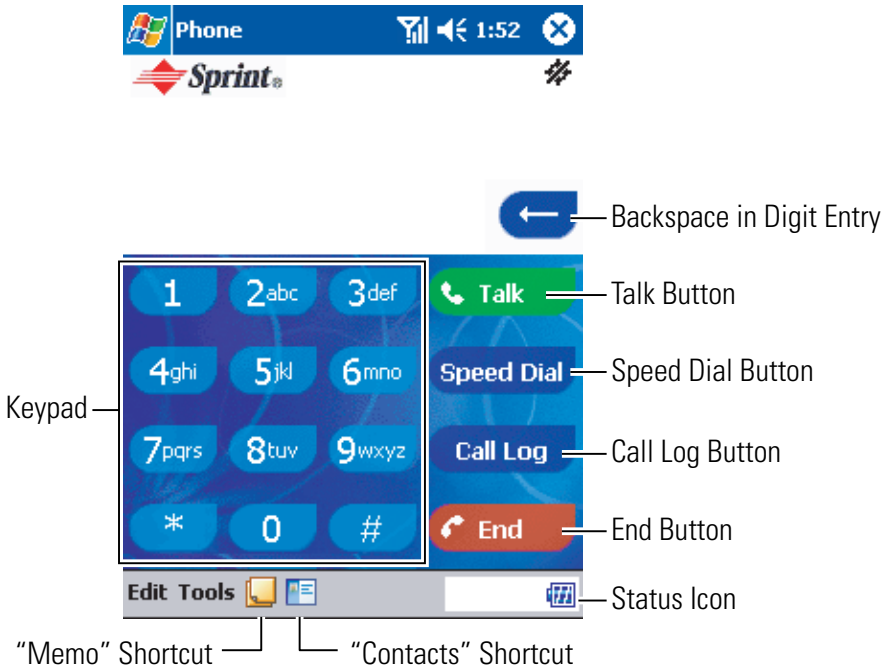

Viewing the Display Screen

Dialer Screen











Keypad Operation List

Regardless of the program in use, pressing the  button while the phone is turned on displays the dialer screen.

When the phone function's screen is displayed, the / buttons on the device perform the same functions as the / buttons on the screen. Button functions include:

Button	Idle	Incoming Call	During a Voice Call
	Call phone number displayed on the screen. If a phone number is not displayed, the last number dialed is called.	Answer a call.	Answer Incoming call; Switch to Three-Way calling.

Button	Idle	Incoming Call	During a Voice Call
	Delete all entered numbers at once.	Silence the ringer or stop vibration. If  is pressed again, it will reject a call.	End all calls.
	Delete entered digits one by one. Tap and hold  to delete the entire number.	—	Delete entered digits one by one. Tap and hold  to delete the entire number.
 :   	Enter the number you wish to call. Tap and hold the Speed Dial location number for one-touch dialing of that number.	—	The number entered is displayed on screen.

Speed Dial button: Tap to view the Speed Dial.

Call Log button: Tap to view the Call Log.

“Memo” Shortcut: Tap to create a note.

“Contacts” Shortcut: Tap to create a contact.

Edit Menu:

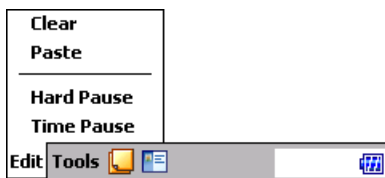

Clear: Delete all entered numbers at once.

Paste: Paste.

Hard Pause: “w” is entered into the number entry field. The next set of numbers are not dialed until you press .

Time Pause: “p” is entered into the number entry field. Your phone automatically sends the next set of numbers after three seconds.

Tools Menu:

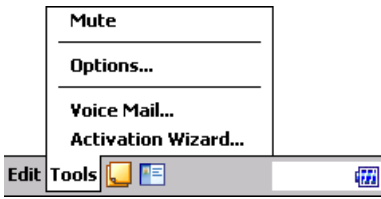

Mute: Tap to mute your phone’s microphone during conversations.





Options: Tap to change phone settings.

Voice Mail: Tap to call your voicemail.





Activation Wizard: Tap to start the Activation Wizard.

Tip: You can also call voicemail by pressing and holding .

Signal Indicator and Icon







Signal Indicator	Description
	Phone is on, but is out of range of any signal.
	Phone is on and is receiving a signal.
	Phone call is in progress. To quickly switch back to Phone from any other program, tap this icon.
	Phone is off. (Airplane mode)

You may also see the following icons while the dialer screen is in display:

Icon	Description
	Phone is in roaming mode.
	Location ON
	Location OFF
	Mute

Status Icon

The following icons appear at the bottom right of the screen:

Icon	Description
	Battery status Full:  (51–100%),  (26–50%),  (11–25%), Empty:  , Charging:  Flash

The following text messages may also appear to the left of the Battery status:

Text message	Description
No Service	Outside of phone service area
Phone OFF	Phone OFF (Airplane mode)
Key Guard	Key guard switch is ON
Silent All, Meeting, Outdoor, Office, Private	Environment status

Note: If more than one of the above conditions is present, text messages in upper rows of the table are given higher priority for display.

Tip: For the icons on the navigation bar, see “Navigation Bar and Command Bar” on page 49.

Turning the Phone ON and OFF

1. Press the Power button to turn the device on, and then press and hold the Power button to turn the phone on. To turn the phone off, press and hold the Power button again. To turn the device off, press the Power button again.

Tip: You may also press and hold the End key to turn the phone on and off.

Tip: You can also turn the phone on by tapping the Signal indicator, instead of pressing and holding the Power button. If you want to make absolutely sure you do not receive calls, such as when you are on an airplane, tap the Signal Indicator again and then tap **Turn phone off**. (The Signal Indicator, located in the navigation bar, indicates whether your phone is on, receiving a signal while on, turned off, and so on.)

2. Press the Talk button. The dialer screen appears and the device is ready to make a phone call.
 - ▶ When the phone is on, the LED for Phone Power blinks at intervals of approximately five seconds.

Displaying Your Phone Number

In case you forget your phone number, your PCS Phone can remind you.

To display your phone number:

- Tap **Tools, Options**, then the **Phone** tab on the bottom.







Tip: You may use the following procedure instead: Tap , then **Settings**. On the **Personal** tab, tap **Phone**, then the **Phone** tab on the bottom.

Making and Answering Calls

Making Calls

Your PCS Phone offers many different ways to make calls, including PCS Voice CommandSM (page 203), using Contacts (page 74), Speed Dialing (page 75), and using Call History (page 109).

To make a call using your keypad:

1. Make sure the phone is on. See page 72 for details.
2. Press  to access the dialer screen.
3. Enter a phone number. If you make a mistake while dialing, tap  to erase one digit at a time. To erase the entire number, tap , tap and hold , or tap **Edit** and **Clear**.
4. Tap  to dial the number.
5. When you're finished, tap  to disconnect the call.

Tip: To redial your last outgoing call, tap .



Tip: When making calls off the Sprint Nationwide PCS Network, always dial using 11 digits (1 + area code + phone number).

Answering Calls

1. Make sure the phone is on.
2. When a call comes in, tap **Answer**.

Depending on your settings, your PCS Phone notifies you of incoming calls in the following ways:

- ▶ The device rings or vibrates.
- ▶ The screen displays an incoming bubble message.
- ▶ If available, the phone number of the caller is displayed.
- ▶ If the phone number is in the Pocket Outlook[®] Contacts list, the list entry's name is displayed.

- To reject an incoming call, tap **Ignore**. (If you reject the call, the busy tone will be sent out or the call will go to voicemail.)
- To silence the ringer and stop vibration, press . Press  again to reject the call.

Note: If the phone is off, incoming calls go to voicemail.

About Caller ID:

If a call is received from a number stored in the Pocket Outlook® Contacts list, the name and number will be displayed. For callers not found in the Contact list, only numbers will be shown.

Calling Emergency Numbers

- You can place calls to 911 (dial    and tap ).

Note: If an emergency number is stored in Speed Dial, you will be able to dial it by tapping a single key. However, speed dial will not work if Key Guard is enabled.

Making a Call From the Internal Phone Book

Phone numbers entered in Contacts can be used to quickly locate phone numbers and make calls.

1. In the contact list, tap and hold the contact.
2. On the pop-up menu, tap **Call** and the type of phone number displayed, such as **Work tel**.

Another way to make calls:

1. In the contact list, tap the contact.
2. Tap **Tools** and **Call** and the type of phone number displayed, such as **Work tel**.

Tip: For details about Contacts, see page 112.

Making a Call From Speed Dial

Speed dialing enables you to quickly place a call simply by tapping a contact or by tapping and holding a Speed Dial location number.

To add a contact to Speed Dial:

1. From the Dialer screen, tap **Speed Dial** and then tap **New**.
2. Tap the contact name and number you want to add.
3. Select an available Speed Dial location number using the arrow keys.
 - ▶ Phone numbers are stored in Speed Dial based on the location number you choose when adding the phone number, rather than by the contact name, and cannot be reorganized. You can store up to 99 numbers in Speed Dial.

To dial a phone number using Speed Dial:

- Tap the **Speed Dial** button and then tap the contact you want to call.

Another way to make calls:

- From the keypad, you can tap and hold the speed dial location number you want to call.
 - ▶ The first location in the speed dial list will automatically be set to your voicemail. To call your voicemail, tap the first location in the speed dial list, and then follow the directions for your voicemail system. (To set up voicemail, see page 188. To use voicemail, see “Using Voicemail” on page 188.)

Making a Call From Call History

The Call Log details all incoming, outgoing, and missed calls, and also provides a summary of total calls. The Call Log can also tell you when a call was initiated, and how long it lasted, and it provides easy access to any notes taken during the call.

To view the call log:

- Tap the **Call Log** button.

To reorganize your call log to view only the information you need:

- Tap the view list (labeled **All Calls** by default) and select a different view. For example, you can view only missed calls, incoming calls, or list calls by caller name.

To respond to the call:

- Tap the **Dial** button located to the left of the number you want to call.

To place a call from Call History:

- See “Making a Call From Call History” on page 109.

Making a Call From 4/5 Digit Dial

4/5 Digit Dial enables you to make a call without entering a complete number. See “Changing the Others Settings” on page 84.

1. Make sure **Prqlaunch** mode is set (4/5 Digit Dial is available).
2. Enter 4 or 5 digits and tap **Talk**.

A programmed number will be automatically added to the beginning of the entered number, or the Contact directory will be searched for phone numbers whose lower digits match the entered number.

Making a Call From Voice Dial

1. Press the Voice button on the side bar of your device.
2. Say the number or a name in Contacts you want to call.
3. Say “Yes” to confirm.

See page 127 to set Voice Dial.

Using Memo

While you are on a call, you can use the Notes application to type, write, draw, or record a Memo (see “Notes: Capturing Thoughts and Ideas” on page 122).

1. To access the Memo function, tap .
2. Take a note.
3. Tap **ok** to close Memo.

After you have finished the note, it will be saved as an attachment to the call in one of the Call Log lists.

- To access a note, tap  in the Call Log list.

Using Speaker Phone

Speaker Phone can be used in any situation where you would like to use your phone without using your hands.

- To turn Speaker Phone on, press the Speaker Phone button.
- To turn Speaker Phone off, press the Speaker Phone button again.

Note: For more information about the phone on your device, tap , and then tap **Help**.

Section 2C

Controlling the Phone Function's Settings

In This Section

- ▶ **Changing the Voicemail Number**
 - ▶ **Changing the Ringer and Key Beep Settings**
 - ▶ **Changing the Location Setting**
 - ▶ **Changing the Environment Mode and Volume and Ring Type/Tone Settings for Individual Modes**
 - ▶ **Data**
 - ▶ **Changing the Others Settings**
 - ▶ **Phone Info**
 - ▶ **TTY**
-

This section describes how you can change the phone function settings for your device.

Changing the Voicemail Number

1. Tap , then **Settings**. On the **Personal** tab, tap **Phone**, then the **Phone** tab on the bottom.
2. Enter the number you wish to call to retrieve your voicemail.



3. Tap **ok**. The Personal tab screen is restored.

Changing the Ringer and Key Beep Settings

1. Tap , then **Settings**. On the **Personal** tab, tap **Phone**, then the **Phone** tab on the bottom.
2. Use the drop-down menus to select settings for Ring type, Ring tone, Keypad, and Other Settings.
3. Tap **ok**. The Personal tab screen is restored.

Note: With the Environment switch set to “Silent”, the above selections will result in no changes.

Changing the Location Setting

Your phone's Location feature allows the network to detect your position and is designed for use in connection with location-based services which may be available in the future.

To turn Location on or off:

1. Tap , then **Settings**. On the **Personal** tab, tap **Phone**, then the **Location** tab on the bottom.
2. Select ON or OFF for the location setting.
 - ▶ **ON:** The user allows search user's position from Network.
 - ▶ **OFF:** The user does not allow search user's position from Network.

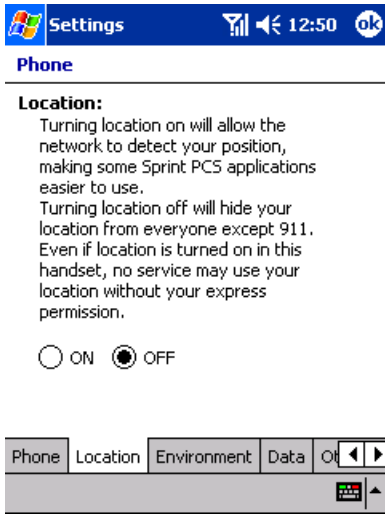

3. Tap **ok**.

- ▶ After a message appears, tap **ok**. The Personal tab screen is restored.

Tip: The current location setting is shown on the dialer screen (and Today screen). For more information, see page 47.

Note: Turning Location off will hide your location from everyone except 911.

Note: Even if the Location feature is enabled, no service may use your location without your expressed permission.

Changing the Environment Mode and Volume and Ring Type/Tone Settings for Individual Modes

When the Environment switch is set to “Environment,” the device is placed into the mode that you select, from “meeting,” “outdoor,” “office,” and “private.” For the individual modes, you can also make selections for volume and ring type/tone.

Tip: The Environment switch is used for changing the volume and ring type/tone settings for incoming calls. For more information, see “Environment Switch” on page 42.

1. Tap , then **Settings**. On the **Personal** tab, tap **Phone**, then the **Environment** tab on the bottom.
 2. Under **Select Mode**, select a desired mode.
 3. Under **Environment**, select a mode to be changed. Then select settings for **Volume** and **Ringer**.
- ▶ You can customize volume and ring type/tone for each mode.

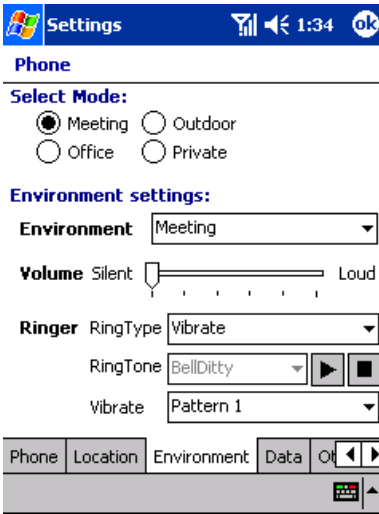

4. Tap **ok**. The Personal tab screen is restored.

The defaults for the individual modes are as below:

Mode	Volume	Ring type	Ring tone	Vibrate
Environment Meeting	OFF (Silent)	Vibrate	None	Pattern1
Outdoor	Max (level 6)	Vibrate and ring	BellDitty	Pattern1
Office	Medium (level 3)	Ring	BellDitty	None
Private	Max (level 6)	Vibrate and ring	BellDitty	Pattern1

Note: The settings made for Sounds & Notification (page 96) and Phone (page 80) will be effective unless the Environment switch is set to a different position.

Data

1. Tap , then **Settings**. On the **Personal** tab, tap **Phone**, then the **Data** tab on the bottom.
 - ▶ Tap **Camera Reset** to clean up registration information of Online pictures.
 - ▶ Tap **Update Data Profile** to pull PCS Vision information such as user ID and password from the network.

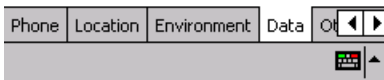
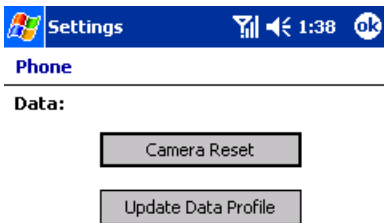

Changing the Others Settings

You can select various settings for other phone functions using the Others tab.

1. Tap , then **Settings**. On the **Personal** tab, tap **Phone**, then the **Others** tab on the bottom.
2. Make selections for each item.

▶ **4 or 5 digits dial**

This function allows you to dial a number using only four or five digits, either by programming a number to automatically be added to the entered digits or by searching the Contacts directory for a phone number containing the entered digits.

Abbreviate: Check the box to add a programmed number to the beginning of an entered number. For Prefix, enter a number to be added.

Contact match: Check the box to search the Contact directory for phone numbers whose lower digits match the entered number.

- ▶ **On battery power:** Check the box to darken the screen during conversations.

Tip: The screen will be automatically darkened when conversations are continued for 60 seconds. When the screen is off, pressing the POWER, TALK buttons, or operating the jog-wheel turns the screen on.

▶ **Answer**

This function allows you to select settings for answering incoming calls.

Any key answer: When Any-key answer is checked, incoming calls can be answered by pressing any key other than the END, Power, Key Guard buttons, Environment switch and Shift, Num, Fn keys on the QWERTY keyboard. However, this function isn't enabled in the Key Guard state.

Auto Answer: When Auto Answer is checked, incoming calls can be answered after nine seconds. The entered end key becomes invalid.

Use Headset: Incoming calls can be answered only when Headset is being inserted into the device.

All: Incoming calls can be answered on external power state.

Speaker Phone ON: Speaker phone is turned on during call.

Tip: Selections for Use Headset, All, and Speaker Phone On are valid only when the box for Auto answer has been checked.

- ▶ **Automatic:** Seeks service on the Sprint Nationwide PCS Network. If PCS Service is unavailable, the phone searches for an alternate system.

When **Display message at Roaming Area in begin call state** is checked, the text message “Caution! This operation will be charged” appears in the incoming or outgoing bubble message or message window on the dialer.

- ▶ **Sprint:** Allows you to access the Sprint Nationwide PCS Network only and prevents roaming on other networks.

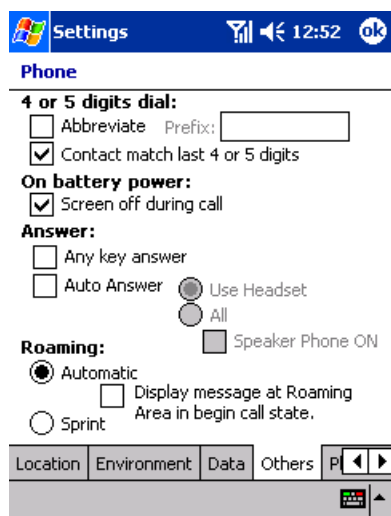

3. Tap **ok**. The Personal tab screen is restored.

Phone Info

1. Tap , then **Settings**. On the **Personal** tab, tap **Phone**, then the **Phone Info** tab on the bottom.
2. Your Phone information is displayed.

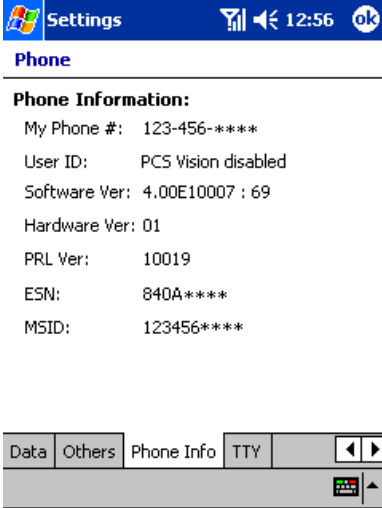

3. Tap **ok**.

Tip: For the User ID, “PCS Vision disabled” appears with data connection disabled, and a user ID appears with data connection enabled.

TTY

A TTY (also known as a TDD or Text Telephone), is a telecommunications device that allows people who are deaf or hard of hearing, or who have speech or language disabilities, to communicate by telephone.

Your phone is compatible with select TTY devices. Please check with the manufacturer of your TTY device to ensure that it supports digital wireless transmission. Your phone and TTY device will connect via a special cable that plugs into your phone's headset jack. If this cable was not provided with your TTY device, contact your TTY device manufacturer to purchase the connector cable.

Use the following procedure to make a setting for TTY:

1. Tap , then **Settings**. On the **Personal** tab, tap **Phone**, then the **TTY** tab on the bottom.

Tip: When you enter “##889” (TTY) on the dialer, the TTY setting screen is opened.

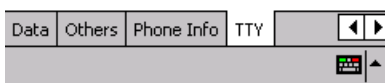
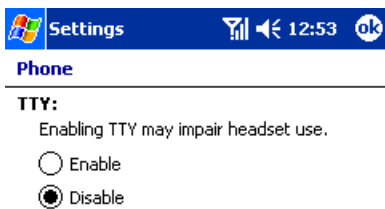

2. When you select **Enable**, “TTY is enabled” appears.
3. Tap **ok** at the top right of the screen to close the setting screen.
4. Insert the TTY into the headset jack.

Note: Malfunction may occur if you insert the TTY into the headset jack without doing steps 1 to 3.

5. “TTY is available” appears.

Note: You cannot change the TTY setting during a call.

IMPORTANT NOTICE: 911 Emergency Calling

Sprint recommends that TTY users make emergency calls by other means including Telecommunications Relay Services (TRS), analog cellular, and landline communications. Wireless TTY calls to 911 may be corrupted when received by public safety answering points (PSAPs) rendering some communications unintelligible. The problem encountered appears related to TTY equipment or software used by PSAPs. This matter has been brought to the attention of the FCC, and the wireless industry and PSAP community are currently working to resolve this.

Section 2D

Controlling Your Device's Settings

In This Section

- ▶ **Adjusting Settings**
 - ▶ **Adding or Removing Programs**
 - ▶ **Setting Buttons**
 - ▶ **Setting a Password**
 - ▶ **Selecting Sounds & Notifications Settings**
 - ▶ **Selecting Backlight Settings**
 - ▶ **Adjusting Memory Settings**
 - ▶ **Setting the Microphone**
 - ▶ **Adjusting Power Settings**
 - ▶ **Customizing Regional Settings**
-

This section describes the procedures for making various settings to customize your device.

Adjusting Settings

You can adjust device settings to suit the way you work. To see available options, tap , **Settings**, then the **Personal** or **System** tab located at the bottom of the screen.

You might want to adjust the following:

- ▶ **Backlight:** See “Selecting Backlight Settings” on page 97.
- ▶ **Buttons:** See “Setting Buttons” on page 94.
- ▶ **Clock:** To change the time or to set alarms.
- ▶ **Input:** To set up the input methods of your device.
- ▶ **Memory:** See “Adjusting Memory Settings” on page 98.
- ▶ **Menus:** To customize what appears on the  menu, and to enable a pop-up menu from the **New** button.
- ▶ **Microphone:** See “Setting the Microphone” on page 99.
- ▶ **Owner Information:** To enter your contact information.
- ▶ **Password:** To limit access to your device. See “Setting a Password” on page 95.
- ▶ **Power:** To maximize battery life. See “Adjusting Power Settings” on page 100.
- ▶ **Regional Settings:** See “Customizing Regional Settings” on page 101.
- ▶ **Remove Programs:** See “Adding or Removing Programs” on page 91.
- ▶ **Screen:** To recalibrate the screen and enable/disable the Clear Type feature.
- ▶ **Sound & Notification:** See “Selecting Sounds & Notifications Settings” on page 96.
- ▶ **Today:** To customize the look and the information that is displayed on the Today screen.

Adding or Removing Programs

Programs installed to your device at the factory are stored in ROM (read-only memory). You cannot remove this software, and you'll never accidentally lose ROM contents. ROM programs can be updated using special installation programs with a *.xip extension. All other programs and data files added to your device after factory installation are stored in RAM (random access memory).

You can install any program created for your device, as long as your device has enough memory. The most popular place to find software for your device is on the Pocket PC Website (<http://www.microsoft.com/mobile/pocketpc>).

To add programs using ActiveSync:

You'll need to install the appropriate software for your device on your desktop computer before installing it on your device.

Note: Determine your device and processor type so that you know which version of the software to install. Tap , and then **Settings**. On the **System** tab, tap **About**. In the **Version** tab, make a note of the information in **Processor**.

1. Download the program to your computer (or insert the CD or disk that contains the program into your computer). You may see a single *.xip, *.exe, *.zip file, a Setup.exe file, or several versions of files for different device types and processors. Be sure to select the program designed for the Pocket PC and your device processor type.
 2. Read any installation instructions, Read Me files, or documentation that comes with the program. Many programs provide special installation instructions.
 3. Connect your device and computer via the USB port. (See “Using the USB Port” on page 32.)
 4. Double-click the *.exe file.
- ▶ If the file is an installer, the installation wizard will begin. Follow the directions on the screen. Once the software has been installed on your

computer, the installer will automatically transfer the software to your device.

- ▶ If the file is not an installer, you will see an error message stating that the program is valid but it is designed for a different type of computer. You will need to move this file to your device. If you cannot find any installation instructions for the program in the Read Me file or documentation, use ActiveSync Explore to copy the program file to the Program Files folder on your device. For more information on copying files using ActiveSync, see ActiveSync Help.





Once installation is complete, tap , **Programs**, and then the program icon to switch to it.

To add a program directly from the Internet:

Note: Determine your device and processor type so that you know which version of the software to install. Tap  and then **Settings**. On the **System** tab, tap **About**. In the **Version** tab, make a note of the information in Processor.

1. Download the program to your device straight from the Internet using Pocket Internet Explorer. You may see a single *.xip, *.exe, *.zip file, a Setup.exe file, or several versions of files for different device types and processors. Be sure to select the program designed for the Pocket PC and your device processor type.
2. Read any installation instructions, Read Me files, or documentation that comes with the program. Many programs provide special installation instructions.
3. Tap the file, such as a *.xip or *.exe file. The installation wizard will begin. Follow the directions on the screen.

To add a program to the Start menu:

- Tap , **Settings**, **Menus**, the **Start Menu** tab, and then the check box for the program. If you do not see the program listed, you can either use File Explorer on the device to move the program to the Start Menu folder, or use ActiveSync on the computer to create a shortcut to the program and place the shortcut in the Start Menu folder.
- ▶ **Using File Explorer on the device:** Tap , **Programs**, **File Explorer**, and locate the program (tap the folder list, labeled **My Documents** by default, and then **My Device** to see a list of all folders on the device). Tap and hold the program and tap **Cut** on the pop-up menu. Open the Start Menu folder located in the Windows folder, tap and hold a blank area of the window, and tap **Paste** on the pop-up menu. The program will now appear on the  menu.
- ▶ **Using ActiveSync on the computer:** Use the Explorer in ActiveSync to explore your device files and locate the program. Right-click the program, and then click **Create Shortcut**. Move the shortcut to the Start Menu folder in the Windows folder. The shortcut now appears on the  menu. For more information, see ActiveSync Help.

To remove programs:

- Tap  and then **Settings**. On the **System** tab, tap **Remove Programs**.

If the program does not appear in the list of installed programs, use File Explorer on your device to locate the program, tap and hold the program, and then tap **Delete** on the pop-up menu.

Setting Buttons

To assign application programs to Application launch keys (A1–A8):

1. Tap , then **Settings**. On the **Personal** tab, tap **Buttons**, then the **Program Buttons** tab on the bottom.
2. Select functions to be assigned to the individual buttons.

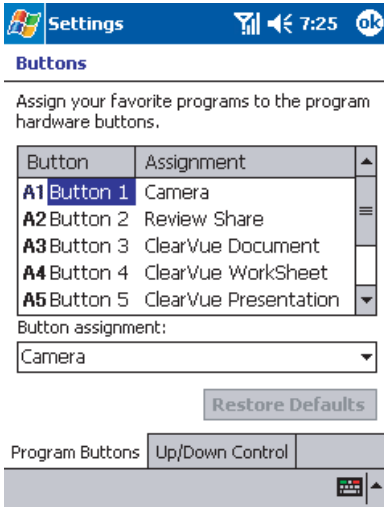

Defaults:

- A1 Camera
- A2 Review Share
- A3 ClearVue Document
- A4 ClearVue WorkSheet
- A5 ClearVue Presentation
- A6 ClearVue PDF
- A7 Data Backup
- A8 World Clock

3. Tap **ok**. The Personal tab screen is restored.

When you press the “Fn” key while operating the device, the following operation window is displayed on the screen:

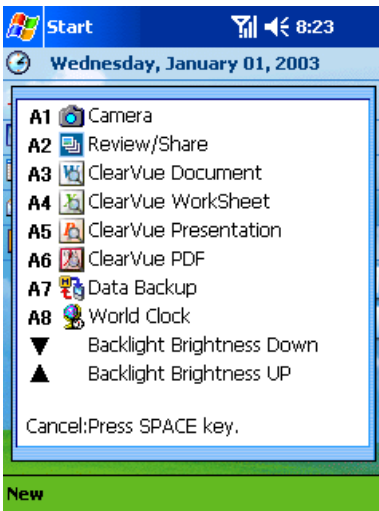

Setting a Password

You can protect data or settings from another person by setting a password for access. The password is requested when turning power on.

1. Tap , then **Settings**. On the **Personal** tab, tap **Password**.
2. Select the type of password you would like to use.

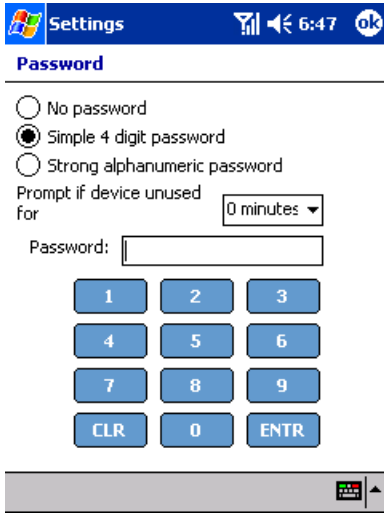

- ▶ When a strong alphanumeric password is selected, your password must be at least seven characters long and contain a combination of uppercase letters, lowercase letters, numerals, or punctuation.
3. Select how long your device must be turned off before the password is required to use your device.
 4. Enter a password and tap **ok**.
 5. Tap **YES** on the confirmation screen. The password is saved and the screen returns to the Personal tab screen.

Note: Record your password in a safe place. If you wish to change your password, you will have to know the existing one to access the Password setting screen. If you forget your password, you will have to initialize the device, which deletes all stored data and settings.

Selecting Sounds & Notifications Settings

To select preferences for Sounds and Notifications, such as alarm volume and duration:

1. Tap , then **Settings**. On the **Personal** tab, tap **Sounds & Notifications**.
2. Make selections for Sounds & Notifications.



3. Tap **ok**. Personal tab screen is restored.

Note: With the Environment switch set to "Silent," the above selections for "System volume" under Volume tab and "Select an event → Incoming call" under Notifications tab will result in no changes.

Selecting Backlight Settings

To customize the backlight brightness and automatic turn-off for power saving purposes:

1. Tap , then **Settings**. On the **System** tab, tap **Backlight**.
2. Select backlight settings.

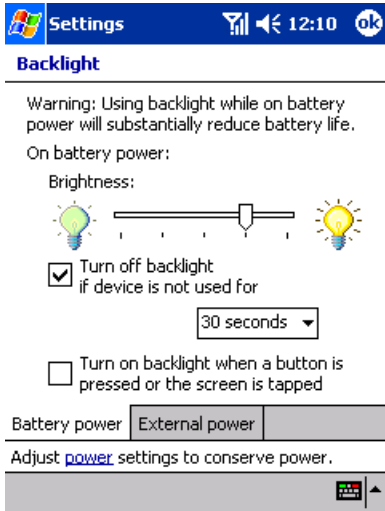

3. Tap **ok**. The System tab screen is restored.

Adjusting Memory Settings

You can adjust the amount of memory allocated for storing data and for running programs. You can also confirm the amount of free space available on a storage card. Memory for the device is managed automatically.

Changing the memory allocation

1. Tap , then **Settings**. On the **System** tab, tap **Memory**.
2. Drag the slider in either direction to adjust the allocation of memory for data storage and program execution.

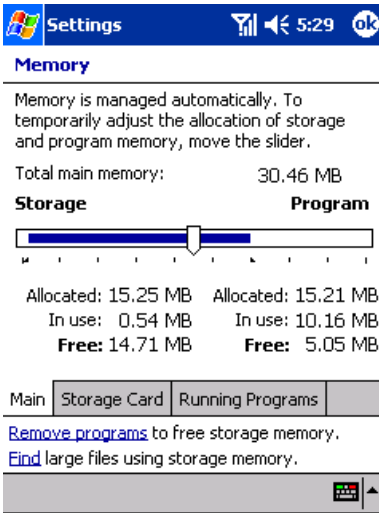

3. Tap **ok**. The System tab screen is restored.

Setting the Microphone

When Automatic Gain Control is on, the sensitivity of the microphone is automatically adjusted to best pick up changing sound levels.

To specify whether to enable or disable the Auto Gain Control function:

1. Tap , then **Settings**. On the **System** tab, tap **Microphone**.
2. Select **Enable** or **Disable** for Auto Gain Control.
 - ▶ **Enable** AGC: Turn on automatic gain control for the microphone.
 - ▶ **Disable** Turn off automatic gain control for the microphone.

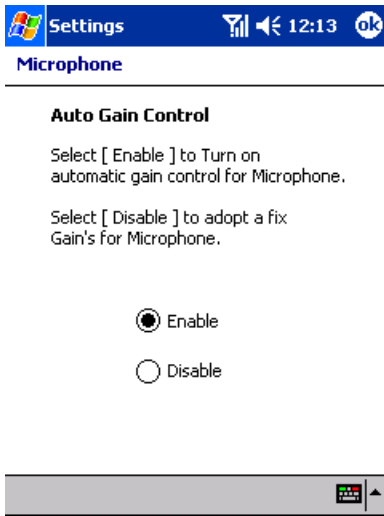

3. Tap **ok**. The System tab screen is restored.

Adjusting Power Settings

To confirm the battery power remaining and the time that elapses until the power turns off after the last operation:

1. Tap , then **Settings**. On the **System** tab, tap **Power**.
2. Select Power settings.

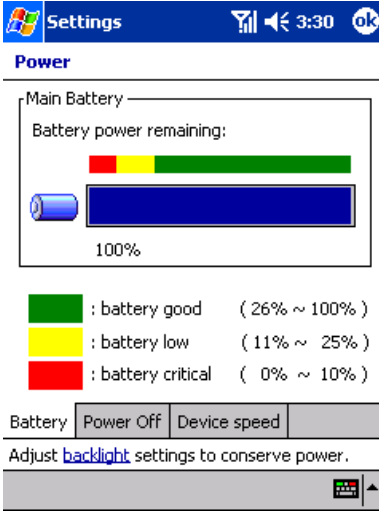

3. Tap **ok**. The System tab screen is restored.

Customizing Regional Settings

To customize language, number format, currency, time, and date display:

1. Tap , then **Settings**. On the **System** tab, tap **Regional Settings**.
2. Make selections for regional settings.

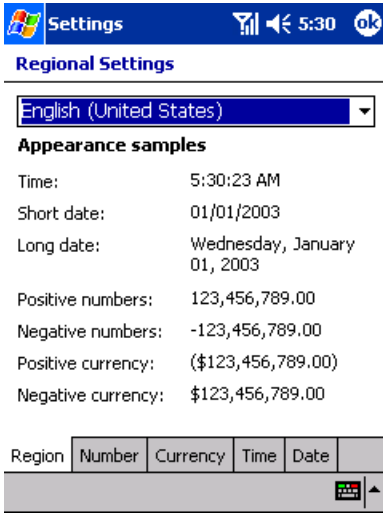

3. Tap **ok**. The System tab screen is restored.

Section 2E

Controlling Your Roaming Experience

In This Section

- ▶ **Understanding Roaming**
 - ▶ **Setting Your Device's Roam Mode**
 - ▶ **Controlling Roaming Charges Using Call Guard**
-

Roaming is the ability to make or receive calls while you're off the Sprint Nationwide PCS Network. Your new single band PCS Phone works anywhere on the Sprint Nationwide PCS Network and allows you to roam on digital networks where compatible wireless service is available.

This section explains how roaming works as well as special features that let you manage your roaming experience.

Understanding Roaming

Recognizing Icon on the Display Screen

Your phone's display screen always lets you know when you're off the Sprint Nationwide PCS Network and start roaming by displaying the  icon.

Tip: Remember, when you are using your device off the Sprint Nationwide PCS Network, always dial numbers using 11 digits (1 + area code + number).

Note: You will pay a higher per-minute rate for roaming calls.

Roaming on Other Digital Networks

When you're roaming on other digital networks, your call quality and security will be similar to the quality you receive when making calls while on the Sprint Nationwide PCS Network. You may not be able to access certain calling features, such as PCS Vision.

Tip: If you're on a call when you leave the Sprint Nationwide PCS Network and enter an area where roaming is available, your call is dropped. If your call is dropped in an area where you think PCS Service is available, turn your phone off and on again to reconnect to the Sprint Nationwide PCS Network.

Setting Your Device's Roam Mode

Your PCS Phone allows you to control your ability to roam. By using the **Roaming** menu option, you can determine which signals your device accepts.

Set Mode

Choose from two different settings on your device to control your roaming experience:

1. From the dialer screen, tap **Options** on the **Tools** menu to display the Phone setting screen.
2. Tap the **Others** tab.

3. Check **Automatic** or **Sprint**.

- ▶ **Automatic:** This setting seeks PCS Service. When PCS Service is unavailable, the phone searches for an alternative system.
- ▶ **Sprint:** This setting allows you to select the Sprint Nationwide PCS Network only and prevents roaming on other networks.

Controlling Roaming Charges Using Call Guard

In addition to the roaming icon, Call Guard alerts you when roaming charges apply. This feature makes it easy to manage your roaming charges by reminding you when you make or receive roaming calls. It also requires you to take additional steps before placing or answering a roaming call. These additional steps are not required when you make or receive calls while on the Sprint Nationwide PCS Network.

To Turn the Call Guard Feature On or Off:

1. From the dialer screen, tap **Options** on the **Tools** menu to display the Phone setting screen.
2. Tap the **Others** tab.
3. Check **Automatic**.
4. Check “**Display message at Roaming Area begin call state.**” to turn the Call Guard on. To turn the Call Guard off, clear the checkbox.

To Place Roaming Calls With Call Guard On:

1. Place a call.
2. Tap **Continue** when the message screen appears.

To Answer Incoming Roaming Calls With Call Guard On:

- Tap **Continue** in the message screen.

Section 2F

Managing Call History

In This Section

- ▶ **Viewing History**
 - ▶ **Call History Options**
 - ▶ **Making a Call From Call History**
 - ▶ **Saving a Phone Number From Call History**
 - ▶ **Erasing Call History**
-

The Call History helps you manage your time more effectively. It keeps track of incoming calls, calls made from your PCS Phone, and missed calls. This section guides you through accessing and making the most of your Call History.

Viewing History

The Call Log screen displays a list of incoming, outgoing, and missed calls, including caller information and call time.

To view the Call Log screen:

- From the Dialer, tap **Call Log**.

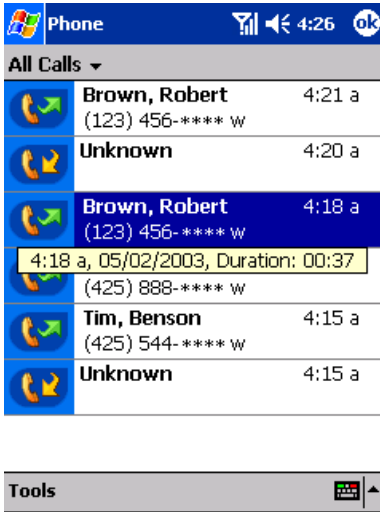

To select the Call Log list you wish to view:

1. Tap the view list on the screen.
2. Select the one you wish to view.

- ▶ Lists are **All Calls, Missed, Outgoing, Incoming, By Caller ...**

To view details:

- Tap a log entry to display Details. Details include time, date, and call duration.

Call History Options

To view Call History options:

- Tap **Tools**, then **Options**.
- ▶ You can see lifetime number of calls and total time.
- ▶ You can see and reset trip odometer number of calls and total time since you last emptied the call log.
- ▶ You can delete items older than a certain period of time.

Making a Call From Call History

To place a call from Call History:

- Tap the **Dial** button located to the left of the number you want to call.

You can also place a call as follows:

1. Tap and hold the number on the screen.
2. When the pop-up menu appears, tap **Call**.

Note: You cannot make calls from Call History to entries identified as No ID or Restricted.

Saving a Phone Number From Call History

You can keep telephone numbers in “Contacts” in Microsoft® Pocket Outlook®.

1. Tap and hold the Call History to be registered, then select **New Contacts**.
 2. Enter necessary information on the Contacts screen to perform registration.
- ▶ For details about Contacts, see page 112.

Note: You cannot save phone numbers from calls identified as No ID or Restricted.

Erasing Call History

To erase individual Call History entries:

1. Tap and hold the number on the screen.
2. When the pop-up menu appears, tap **Delete**.

To erase Call History:

- Tap **Tools**, then **Delete all calls**.

Section 2G

Using Microsoft® Pocket Outlook®

In This Section

- ▶ **Contacts: Tracking Friends and Colleagues**
 - ▶ **Calendar: Scheduling Appointments and Meetings**
 - ▶ **Tasks: Keeping a To Do List**
 - ▶ **Notes: Capturing Thoughts and Ideas**
-

If the contact data on your personal computer is in Microsoft® Outlook®, the Microsoft® Pocket Outlook® application on this device can read and import the contact data. This section explains how to use Microsoft Pocket Outlook.

Microsoft Pocket Outlook includes Calendar, Contacts, Tasks, Inbox, and Notes, which can be used individually or together. For example, email addresses stored in Contacts can be used to address email messages in Inbox. ActiveSync® synchronizes information in Microsoft® Outlook® or Microsoft® Exchange on your computer with your device, comparing changes made on both and updating each with the latest information. For information on using ActiveSync®, see ActiveSync® Help on your computer.

Contacts: Tracking Friends and Colleagues

Contacts maintains an easily accessible list of friends and colleagues. Your device's infrared (IR) port allows you to quickly share Contacts information with other devices.

- To access Contacts, tap the Contacts Icon from the dialer screen, or tap , then **Contacts**.

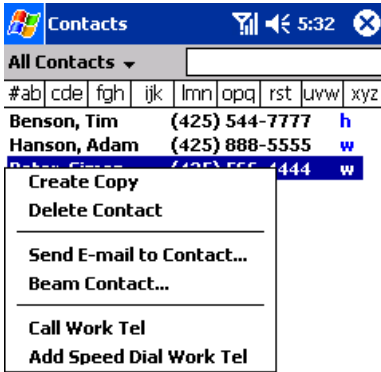

- ▶ Tap **All Contacts** to select the category of contacts you want displayed in the list.
- ▶ Tap the search box and enter part of a name to quickly find it in the list.
- ▶ Tap a contact to display or edit details.
- ▶ Tap and hold a contact to display a pop-up menu of actions.
- ▶ Tap to the right of a contact to see additional phone number and email addresses for the contact.

Note: Tap **Tools** then **Options** to change the way information is displayed in the contact list.

Note: When transferring the contact to another device by using infrared (IR), tap and hold that contact, then tap **Beam Contact** from the displayed pop-up menu. For more information, see "Sending Files Using Infrared Rays" on page 166.

Creating a Contact

1. From the Contacts screen, tap **New**.

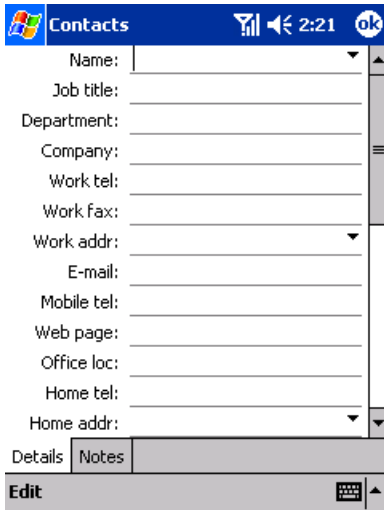

2. Enter a name and other contact information. Scroll down to see all available fields.

Tip: To enter a hard pause or time pause in the phone number entry field, select **HardPause/TimePause** from the **Edit** menu.

3. Scroll and tap **Categories** and select a category from the list to assign the contact to a category.
4. Tap the **Notes** tab to add notes. Enter text, draw, or create a recording. (See “Notes: Capturing Thoughts and Ideas” on page 122 for details.)
5. When finished, tap **ok** to return to the contact list.

Finding a Contact

There are four ways to find a contact:

- In the contact list, enter a contact name in the box under the navigation bar.

To show all contacts again, clear text from the box or tap the button to the right of the box.

- In the contact list, tap the category list (labeled **All Contacts** by default) and select the type of contact that you want displayed.

To show all contacts again, select **All Contacts**.

To view a contact not assigned to a category, select **None**.

- To view the names of companies your contacts work for, in the contact list, tap **View**, then **By Company**.

The number of contacts that work for that company will be displayed to the right of the company name.

- Tap , **Find**, enter the contact name, select **Contacts** for the type, and then tap **Go**.

Using the Summary Screen

- Tap a contact in the contact list to display a summary screen. Tap **Edit** to change the contact information.

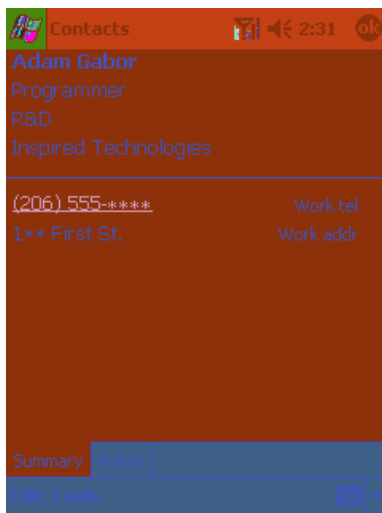

Making a Call From Contacts

See “Making a Call From the Internal Phone Book” on page 74.

Assigning a Picture to a Contact (Picture Display Mode)

1. Tap **View**, then select **By Picture**.
 - ▶ The picture display mode as shown is recalled.

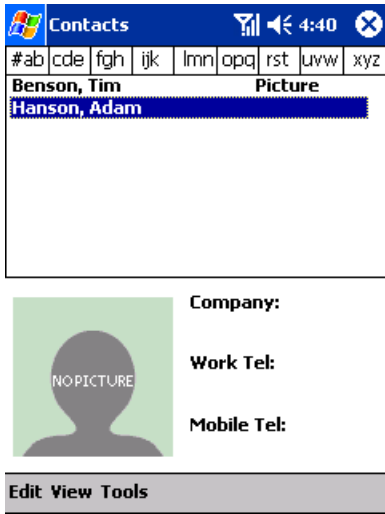

Tip: For contacts with pictures assigned, “Picture” appears to the right of the list.

2. Select a Contact to which a picture is assigned, tap **Tools**, and then select **Select Picture...**
3. Select a picture to be assigned.
4. The picture is assigned to the specified Contact.

Tip: You can trim the assigned picture to 100 × 100 pixels. To trim the picture, select **Crop Picture** from the **Edit** menu.

Tip: To delete the assigned picture, select **Delete Picture** from the **Edit** menu.

Tip: To send a picture to another device using infrared rays, select **Beam Picture...** from the **Tools** menu.

Tip: To restore a mode that does not display picture, tap **View**, and then select **By Picture**.





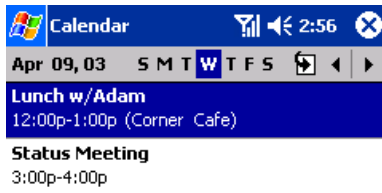

Note: You cannot make a phone call through a list shown in the picture display mode.

Calendar: Scheduling Appointments and Meetings

Use Calendar to schedule appointments, including meetings and other events. You can check your appointments in one of several views (Agenda, Day, Week, Month, and Year) and easily switch views by tapping one of the five view icons at the bottom of the screen.

- To access the Calendar, tap , then **Calendar**.



- ▶ Tap  to go to today.
- ▶ Tap on an appointment to display or edit the details.
- ▶ Tap , , , , or  to switch between the 5 views (Agenda, Day, Week, Month, and Year).

Note: Tap **Options** on the **Tools** menu to customize the Calendar display.

Creating an Appointment

If you are in Day or Week view, tap the desired date and time for the appointment.



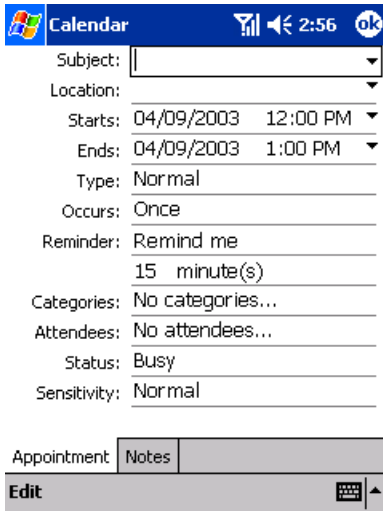

1. Tap **New**.



The screenshot shows the 'New Appointment' form in Microsoft Pocket Outlook. The form is titled 'Calendar' and has a status bar at the top showing the time as 2:56. The form contains the following fields:

- Subject: [Empty text box]
- Location: [Empty text box]
- Starts: 04/09/2003 12:00 PM
- Ends: 04/09/2003 1:00 PM
- Type: Normal
- Occurs: Once
- Reminder: Remind me, 15 minute(s)
- Categories: No categories...
- Attendees: No attendees...
- Status: Busy
- Sensitivity: Normal

At the bottom of the form, there are two tabs: 'Appointment' and 'Notes'. Below the tabs is an 'Edit' button and a keyboard icon.

- ▶ Tap **ok** to return to the calendar (the appointment is saved automatically).
 - ▶ Tap  in the Subject section to choose from predefined text.
 - ▶ Tap  in the Location section to choose from previously entered locations.
 - ▶ Tap  in the Starts section to select a start time.
 - ▶ Tap  in the Ends section to select an end time.
 - ▶ Notes is a good place for maps and directions.
2. Enter a subject (description) and location.
 3. Adjust the date and time as needed.
 4. Enter other desired information. Hide the input panel to view all available fields, if necessary.
 5. Tap the **Notes** tab to add notes or a drawing, or to create a recording. For more information see “Notes: Capturing Thoughts and Ideas” on page 122”.
 6. Tap **ok** when finished. The appointment is saved automatically.

Note: If you select **Remind me** in an appointment, your device will remind you according to the options set in the  menu, **Settings, Personal** tab, **Sounds & Notifications**.

Using the Summary Screen

- Tap an appointment to display the summary screen. To make changes, tap **Edit**.

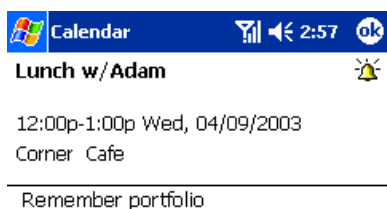

Creating Meeting Requests

Calendar can set up meetings with other Outlook® or Pocket Outlook® users. The meeting request will be created automatically and sent either when you synchronize Inbox or when you connect to your email server. Indicate how you want meeting requests sent by tapping **Tools**, then **Options**. If you send and receive email messages through ActiveSync®, select **ActiveSync**.

To schedule a meeting:

1. Create an appointment.
2. In the appointment details, hide the input panel, then tap **Attendees**.
3. Select the meeting attendees from your Contacts list and Tap **ok**.

The meeting notice is created automatically and placed in the Outbox folder.

For more information on sending and receiving meeting requests, see Calendar Help and Inbox Help on the device.

Tasks: Keeping a To Do List

- Tasks helps you keep track of what you need to do. To access Tasks, tap , then **Tasks**.

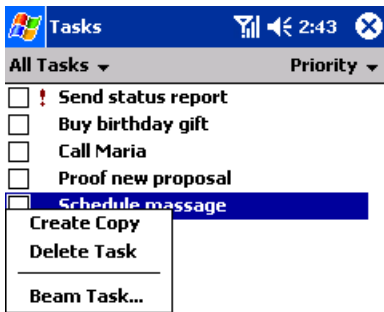

- ▶ Tap **All Tasks** to select the category of tasks you want displayed in the list.
- ▶ Tap **Priority** to select the sort order of the list.
- ▶ **!** indicates high priority.

Tip: ↓ displays on a low priority task, while nothing displays on a normal task.

- ▶ Tap on a task to display or edit the task details.
- ▶ Tap and hold to display a pop-up menu of actions.

Note: Tap **Tools**, then **Options** to change the way information is displayed.

Creating a Task

1. In the Tasks screen, tap **New**.

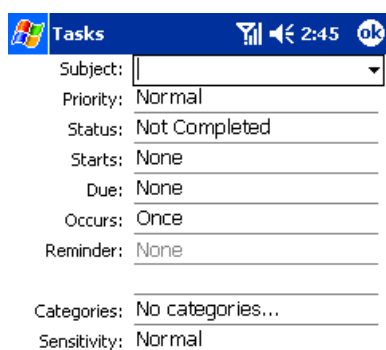

The screenshot shows the 'Tasks' screen with a blue header bar containing the Windows logo, the word 'Tasks', signal strength, battery level, time (2:45), and an 'ok' button. Below the header is a form with the following fields:

- Subject: [Empty text box]
- Priority: Normal
- Status: Not Completed
- Starts: None
- Due: None
- Occurs: Once
- Reminder: None
- Categories: No categories...
- Sensitivity: Normal



The screenshot shows the 'Task' screen with a grey header bar containing the word 'Task' and a 'Notes' tab. Below the header is an 'Edit' button and a keyboard icon.

- ▶ Tap **ok** to return to the task list (the task is saved automatically).
- ▶ Tap  in the subject section to choose from predefined subjects.
- ▶ Notes is a good place for maps and drawings.

2. Enter a subject (description).
3. Enter a start and due date or other information by tapping the field. To see all available fields, hide the input panel (if necessary).
4. Tap **Categories** to assign the task a category. In the list, Tasks can be displayed by category.
5. Tap the **Notes** tab to add notes or a drawing, or to create a recording. For more information, see “Notes: Capturing Thoughts and Ideas” on page 122.
6. Tap **ok** when finished. The task is saved automatically.

Note: To quickly create a task with only a subject, tap **Entry Bar** on the **Tools** menu. Then, tap **Tap here to add a new task** and enter your task information.

Using the Summary Screen

- Tap a task to display the summary screen. To make changes, tap **Edit**.

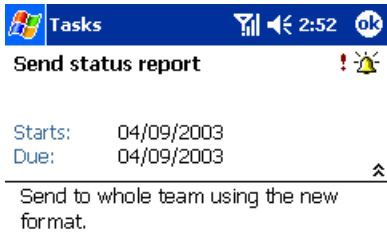



- ▶ Tap \uparrow to show and hide additional summary information.

Notes: Capturing Thoughts and Ideas

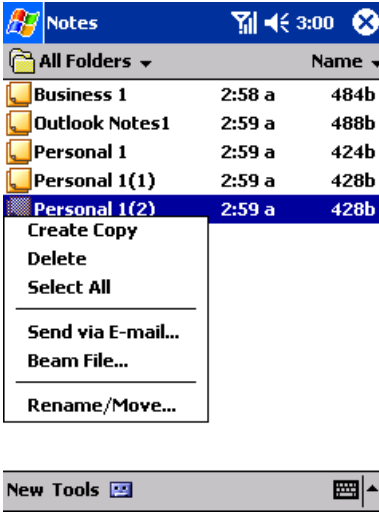
The Notes feature helps you quickly capture thoughts, reminders, ideas, and phone numbers. You can also create a recording to include with an entry.



- ▶ Tap **Name** to change the sort order of the list.
- ▶ Tap on a note to open the note or to play an attached recording.
- ▶ Tap and hold on a note to display a pop-up menu of actions.
- ▶ Tap  to record.
- ▶ Tap  to show or hide the Recording toolbar.

Creating a Note

1. From the Notes screen, Tap **New**.
2. Create your note by writing, drawing, typing, or recording. For more information about using the input panel, writing and drawing on the screen, and creating recordings, see “Entering Text Using the Input Panel” on page 54.

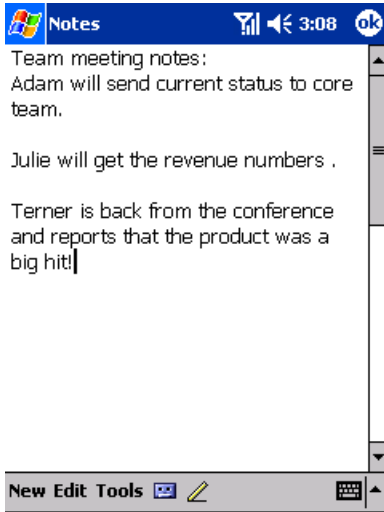

- ▶ Tap **ok** to return to the note list (the note is saved automatically).
- ▶ Tap  to show or hide the Recording toolbar.
- ▶ Tap the **Pen** button to write on the screen.

Section 2H

Using Your Phone's Voice Services

In This Section

- ▶ **Using Voice-Activated Dialing**
 - ▶ **Recording Voice**
-

This section explains the features associated with your phone's Voice Services. The easy-to-follow instructions explain how to make calls and record memos.

Using Voice-Activated Dialing

In addition to Voice CommandSM (see page 203), you can use Voice Dial to dial a phone number stored in Contacts.

Calling by Name

1. Press the Voice button.



2. Say a name in Contacts.
3. Say “Yes” if recognized correctly.

Calling by Phone Number

1. Say “Dial a number.”
2. Say a number.
3. Say “Yes” if recognized correctly.

Note: Recognition may fail in the noisy places. For example, in the running automobile.

Tip: Voice Dial may fail recognition depending on conditions. If this is the case, try the following:

- Open the **Recog** tab on the **VoiceDial Settings** screen (page 127), and perform adjustments for **Recognition performance** and **Recognition rejection**.
 - If names in contacts are not recognized well, place a checkmark in **Contacts** only in the **Contacts** tab on the **VoiceDial Settings** (page 127). Or try registering your voice (nickname feature) in the **Contacts** tab.
-

Note: For the nickname feature, register your voice in a silent room. When making a call using a nickname, pronounce with the same intonation as when you registered.

Selecting Voice Dial Settings

1. Tap , then **Programs**, and select **VoiceDialSetting** to display the VoiceDial Settings screen.

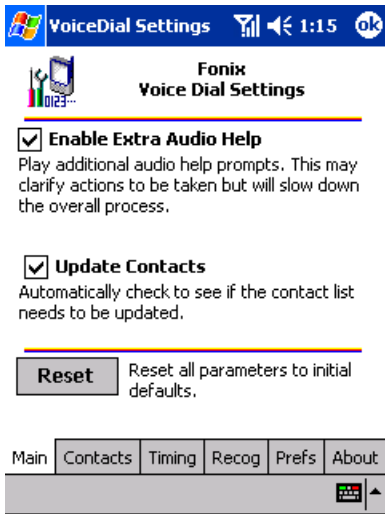

2. Select Settings for VoiceDial.
3. Tap **ok**.

Recording Voice

Your PCS Phone can record your voice. For more information, see “Recording a Message” on page 62.

Section 2I

Using Application Programs

In This Section

- ▶ **Pocket Internet Explorer**
 - ▶ **Inbox: Sending and Receiving Email Messages**
 - ▶ **MSN® Messenger**
 - ▶ **Pocket Word**
 - ▶ **Pocket Excel**
 - ▶ **Windows Media™ Player for Pocket PC**
 - ▶ **Microsoft® Reader**
 - ▶ **Camera**
 - ▶ **Review/Share**
 - ▶ **Online Pictures**
 - ▶ **ClearVue**
 - ▶ **World Clock**
 - ▶ **SaiSuke**
 - ▶ **Installing Application Programs from the Companion CD**
-

This section describes how to use the programs listed above that are installed on your device.

Pocket Internet Explorer

Use Microsoft® Pocket Internet Explorer to view Web or WAP pages in either of these ways:

- ▶ During synchronization with your computer, download your favorite links and mobile favorites that are stored in the Mobile Favorites subfolder in Internet Explorer on the computer.
- ▶ Connect to PCS Connection and browse the Web. When connected to PCS Connection, you can also download files and programs from the Internet.
- To switch to Pocket Internet Explorer, tap  then **Internet Explorer**.

The Mobile Favorites Folder

Only items in your computer's Mobile Favorites folder will be synchronized with your device. This folder is automatically created when ActiveSync® is installed.

Favorite Links

During synchronization, your computer's Mobile Favorites folder is synchronized with your device's Pocket Internet Explorer. Both computers are updated each time you synchronize. If the link is not marked as a mobile favorite, you will have to connect to PCS Connection to view page content. For more information, see ActiveSync® Help on the computer.

Mobile Favorites

If you are using Microsoft® Internet Explorer 5.0 or later on your computer, you can download mobile favorites to your device. Synchronize the Web content of your mobile favorites downloads to your device so that you can view pages while you are disconnected from PCS Connection and computer.

Use the Internet Explorer plug-in installed with ActiveSync® to create mobile favorites quickly.

To create a mobile favorite:

- 1.** In Internet Explorer on your computer, click **Tools** then **Create Mobile Favorite**.
- 2.** To change the link name, enter a new name in the **Name** box.
- 3.** Optionally, in **Update**, select a desired update schedule.
- 4.** Click **OK**. Internet Explorer downloads the latest version of the page to your computer.
- 5.** If you want to download the pages that are linked to the mobile favorites you just created, right-click the mobile favorite then click **Properties**. In the **Download** tab, specify the number of links deep you want to download. To conserve device memory, go only one level deep.
- 6.** Synchronize your device and computer, and the Mobile Favorites folder will be downloaded to your device.

Note: If a scheduled update was not specified in step 3, content will have to be manually downloaded to update both computers. To see the last time content was downloaded to the computer, click **Tools** then **Synchronize** from the Internet Explorer window. Manually download content as needed.

Note: To add a button to your computer's Internet Explorer toolbar for creating mobile favorites, click **View, Toolbars**, then **Customize**.

To minimize the amount of memory used by mobile favorites:

- ▶ In the Favorites settings, select ActiveSync® options and turn off pictures and sounds, or stop select mobile favorites from being downloaded. For more information see ActiveSync® Help.
- ▶ Limit the number of downloaded linked pages. On your computer's Internet Explorer, right click the mobile favorite you want changed and then **Properties**. In the **Download** tab, specify 0 or 1 for the number of linked pages you want to download.

Using AvantGo Channels

AvantGo, a free interactive service that provides access to personalized content and popular Websites, can be subscribed to directly from your device. Content can be downloaded when you synchronize your device and computer, or directly from the Internet. Visit the AvantGo Website for more information.

To sign up for AvantGo:

1. In ActiveSync® options on the computer, turn on synchronization for the AvantGo information type.
2. In Pocket Internet Explorer on your device, tap the **Favorites** button to display your list of favorites.
3. Tap the **AvantGo Channels** link.
4. Follow the directions on the screen.

When synchronization is complete, tap the AvantGo Channels link in your list of favorites to see a few of the most popular channels. To add or remove channels, tap the **Add** or **Remove** link.



Using Pocket Internet Explorer

Pocket Internet Explorer can browse mobile favorites and channels that have been downloaded to your device without connecting to the Internet.

Or, you can connect to the Internet through PCS Connection.



- ▶ Tap  to refresh the page.

- ▶ Tap  to go to the Home page.
- ▶ Tap  to go to your favorites folder.
- ▶ Tap  to hide pictures button.

Viewing mobile favorites:

1. Tap the **Favorites** button to display your list of favorites.

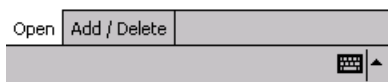
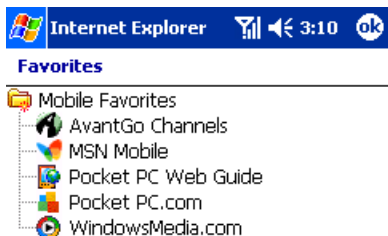

- ▶ Tap **Add/Delete** to add or delete a folder or favorite link.
2. Tap the page you want to view.

The version of the page that was downloaded the last time you synchronized will be displayed. If the page is not on your device, the favorite will be dimmed. Synchronize with your computer to download the page to your device, or connect to the Internet to view the page.

Browsing the Internet:

To connect and start browsing, do one of the following:

- Tap the **Favorites** button, and then tap the favorite you want to view.
- Tap **View** then **Address Bar**. Enter the destination Web address and tap . Tap the arrow to select from previously entered Websites.

Note: To add a favorite link, tap and hold on the page and tap **Add to Favorites** in the pop-up menu.

Inbox: Sending and Receiving Email Messages

Use Inbox to send and receive email messages in either of these ways:

- ▶ Synchronize email messages with Microsoft® Exchange or Microsoft® Outlook® on your computer.
- ▶ Send and receive email messages by connecting directly to an email server through PCS Connection.

Synchronizing Email Messages

Email messages can be synchronized as part of the general synchronization process. You will need to enable Inbox synchronization in ActiveSync®. For information on enabling Inbox synchronization, see ActiveSync® Help on the computer.

During synchronization:

- ▶ Messages are copied from the mail folders of Exchange or Outlook® on your computer to the ActiveSync folder in Inbox on your device. By default, you will receive messages from the past five days only, the first 100 lines of each message, and those not including file attachments.
- ▶ Email messages in the Outbox folder on your device are transferred to Exchange or Outlook®, and then sent from those programs.
- ▶ Email messages in subfolders must be selected in ActiveSync® on your computer in order to be transferred.

Connecting Directly to an Email Server

Your device can send and receive email messages by connecting to an email server. For more information about establishing this remote connection, see “Connecting Directly to an Email Server” on page 171.

Once connected to the email server:

- ▶ New messages are downloaded to the device Inbox folder.
- ▶ Messages in the device Outbox folder are sent.
- ▶ Deleted messages are removed from the device Inbox folder.

Messages received directly from an email server are linked to your email server rather than your computer. When a message is deleted from your device, it will also be deleted from the email server the next time you connect.



When working online connected to your server, you can immediately read and respond to messages – they are sent as soon as you tap **Send**, saving space on your device.

To work offline, download new message headers or partial messages and disconnect from the server. You can then mark which messages to completely download the next time you connect.

Using the Message List

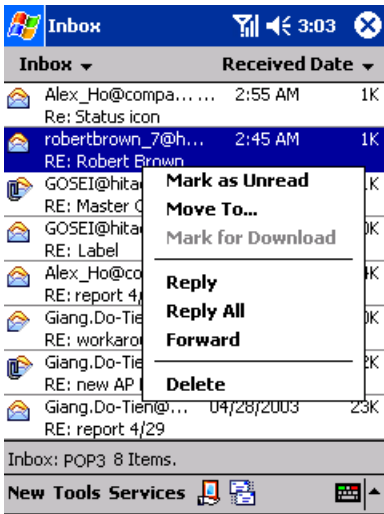



Received messages are displayed in the message list – the most recently received are listed first.

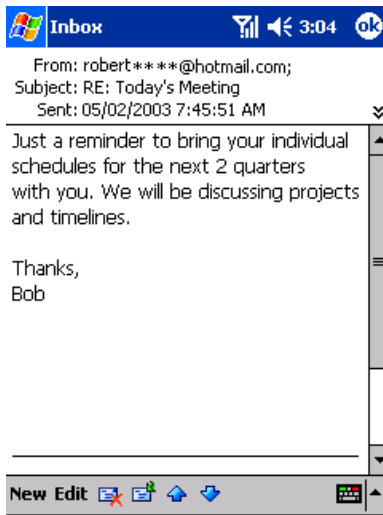

- ▶ Tap **Inbox** to select the service and folder you want to display.
- ▶ Tap **Received Date** to select the sort order for messages.
- ▶ Tap on a message to open the message.
- ▶ Tap and hold to display a pop-up menu of actions.
- ▶ Tap  to connect to the selected service.
- ▶ Tap  to connect and to send and receive email.

- When you receive a message, tap it to open it. Unread messages are displayed in bold.



- ▶ Tap **ok** to return to the message list.
- ▶ Tap  to delete this message.
- ▶ Tap  to reply to or forward this message.
- ▶ Tap  or  to view the previous or next message.
- To retrieve a full message during your next synchronization or email server connection, tap and hold the message. On the pop-up menu tap **Mark for Download**.

Specify downloading preferences when you set up the service or select your synchronization options.



- ▶ Inbox synchronization options can be changed using ActiveSync® options. See ActiveSync® Help for more information.
- ▶ To change options for email server connections, tap **Tools** then tap **Options**. On the **Services** tab, tap the service you want to change. To remove a service, tap and hold the service and select **Delete**.

Composing Messages

1. Tap **New**.
2. In the **To** field, enter the email addresses of the recipients, separating the names with a semi-colon, or select a name from the contact list by tapping and holding **To**, or by tapping the **Address Book** button.

All email addresses entered in the email fields in Contacts appear in the Address Book.



- ▶ Tap  to show or hide the complete header.
 - ▶ Tap  to show / hide the recording toolbar.
 - ▶ Tap  to display the Address Book.
3. Compose your message. To enter preset or frequently used messages, tap **My Text** and select a message.
 4. Tap **Send** when you've finished the message. If you are working offline, the message is moved to the Outbox folder and will be sent the next time you connect.

Managing Email Messages and Folders

Messages are displayed in one of five folders: Inbox, Deleted Items, Drafts, Outbox, and Sent Items. The Deleted Items folder contains messages that have been deleted on the device. The behavior of the Deleted and Sent Items folders depends on the options you have chosen. In the message list, tap **Tools** then **Options**. On the **Message** tab, select your options.

To create new folders, tap **Tools** then **Manage Folders**. For all service except ActiveSync®, you can access folder options by tapping **Tools** then **Manage Folders**. To move a message to another folder, tap and hold the message and then tap **Move to** on the pop-up menu.

Folder behavior with a direct connection to an email server

The behavior of the folders you create depends on whether you are using ActiveSync®, POP3, or IMAP4:

- ▶ If you use ActiveSync®, email messages in the Inbox folder in Outlook® will automatically be synchronized with your device. You can select to synchronize additional folders by designating them for ActiveSync®.

The folders you create and the messages you move will then be mirrored on the server. For example, if you move two messages from the Inbox folder to a folder named Family, and you have designated Family for synchronization, the server creates a copy of the Family folder and copies the messages into that folder. You can then read the messages while away from your computer.

- ▶ If you use POP3 and you move email messages to a folder you created, the link is broken between the messages on the device and their copies on the mail server. The next time you connect, the mail server will see that the messages are missing from the device Inbox and delete them from the server. While this eliminates duplicate copies of messages, you will no longer have access to messages moved to folders created anywhere except the device.
- ▶ If you use IMAP4, the folders you create and the email messages you move are mirrored on the server. Therefore, messages are available to you anytime you connect to your mail server, whether it is from your device or computer.

MSN® Messenger

MSN® Messenger on your mobile device is an instant messaging program that lets you:

- ▶ View a list of instant messaging contacts who are online.
- ▶ Send and receive instant messages.
- ▶ Have instant message conversations with groups of contacts.

To use MSN® Messenger, you must have a Microsoft Passport™ account or a Microsoft® Exchange email account. If you have a Hotmail® or MSN® account, you already have a Passport. Once you have obtained either a Microsoft Passport™ or a Microsoft® Exchange account, you are ready to set up your account.

Note: Sign up for a Microsoft Passport™ account at <http://www.passport.com>. Get a free Microsoft® Hotmail® email address at <http://www.hotmail.com>.

- To switch to MSN® Messenger, tap , **Programs**, then tap **MSN Messenger**.

Setting Up

Before you can connect, you must enter Passport or Exchange account information.

To set up an account and sign in:

1. In the **Tools** menu, tap **Options**.
2. On the **Accounts** tab, enter your Passport or Exchange account information.
3. Tap **ok**.
4. Tap the sign-in screen and tap **Sign in**.

Note: If you use MSN® Messenger on your computer, your contacts will automatically show up on your device.

Working With Contacts

The MSN® Messenger window displays all your message contacts divided into Online and Not Online categories. While connected, tap and hold any contact and a pop-up menu appears allowing you to chat, send email, block the contact, or delete the contact.



Note: To see others online without being seen, in the **Tools** menu, tap **My Status** and select **Appear Offline**.

Note: If you block a contact, you will appear offline but will remain on the blocked contact's list. To unblock a contact, tap and hold the contact, then tap **Unblock** on the pop-up menu.

Chatting With Contacts

- Tap a contact name to open a chat window. Enter your message in the text entry area, or tap **My Text** to enter a preset message, and tap **Send**.
- To invite another contact to a multi-user chat, in the **Tools** menu, tap **Invite** and tap the contact you wish to invite.



Note: To switch back to the main window without closing a chat, tap the **Contacts** button. To revert back to your chat window, tap **Chats** and select the person whom you were chatting with.

- To see if the contact you are chatting with is responding, look for the message under the text entry area.

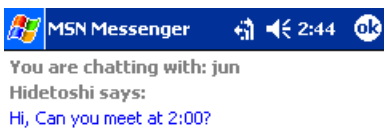

For more information on using MSN[®] Messenger, tap  then **Help**.

Pocket Word

Pocket Word works with Microsoft® Word on your computer, providing easy access to copies of documents. You can also create new documents on your device or copy documents from your computer.

- To create a new file, tap , **Programs**, **Pocket Word**, and then **New**. Or, from the Today screen, tap **New**, then **Word Document**. Only one document can be opened at a time; when you open a second you will have to save the first. Documents can be saved in a variety of formats including Word (.doc), Pocket Word (.psw), Rich Text Format (.rtf), and Plain Text (.txt).

Pocket Word contains a list of stored files. Tap a file to open it, and tap and hold to delete, make copies of, or send it from the pop-up menu.

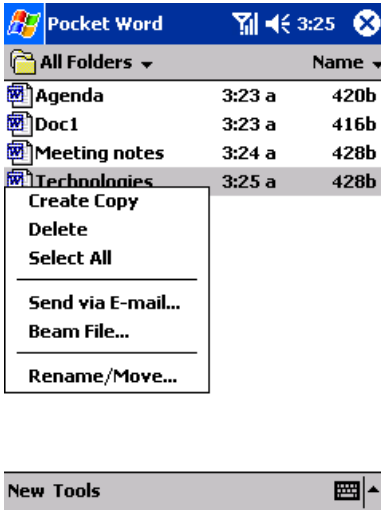

- ▶ Tap **Name** to change the sort order of the list.
- ▶ Tap **All Folders** to select the type of folder you want displayed in the list.
- ▶ Tap **New** to create a new document.
- ▶ Tap on a document name to open the document.
- ▶ Tap and hold an item to see a pop-up menu of actions.

You can enter information in Pocket Word in one of four modes (typing, writing, drawing, and recording), which are displayed on the **View** menu.

Each mode has its own toolbar, which you can show and hide by tapping the **Show/Hide Toolbar** button on the command bar.

Tip: You can change the zoom magnification by tapping **View** and then **Zoom**. Then select the percentage you want. Select a higher percentage to enter text and a lower one to see more of your document.

Tip: If you're opening a Word document created on a computer, select **Wrap to Window** on the **View** menu so that you can see the entire document.

Typing Mode

- Enter text using the input panel (see “Entering Text Using the Input Panel” on page 54 for more information).
- To format or edit text, highlight it by dragging the stylus over the text you wish to select. Use the **Edit** menu or toolbars for formatting changes.
- To search for text within a document, tap **Edit** and then **Find/Replace**.

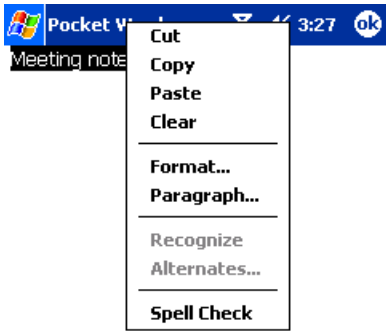



- ▶ Tap **F** to change the formatting options.
- ▶ Tap  to show or hide the toolbar.

Writing Mode

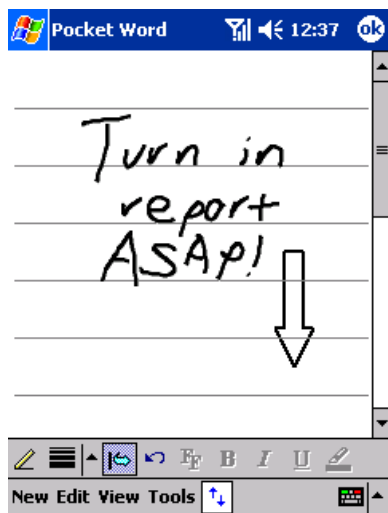
- In writing mode, use your stylus to write directly on the screen. Ruled lines are displayed as a guide, and the zoom magnification is greater than in typing mode to allow you to write more easily. For more information on writing and selecting writing, see “Entering Text Using the Input Panel” on page 54.



- ▶ Tap  to select the Pen tool.
- ▶ Tap  to select the Space tool. With Space tool selected, drag to insert a space. An arrow appears showing the space direction and size.
- ▶ Tap  to change the formatting options, such as pen weight, line/font color, and fill color.

Note: If you cross three ruled lines in a single stylus stroke, the writing becomes a drawing, and can be edited and manipulated as described in the following section.

Note: Written words are converted to graphics (metafiles) when a Pocket Word document is converted to a Word document on your computer.

Drawing Mode

In drawing mode, use your stylus to draw on the screen. Gridlines appear as a guide. When you lift your stylus off the screen after the first stroke, you'll see a drawing box indicating the boundaries of the drawing. Every subsequent stroke within or touching the drawing box becomes part of the drawing. For more information on drawing and selecting drawings, see “Entering Text Using the Input Panel” on page 54.

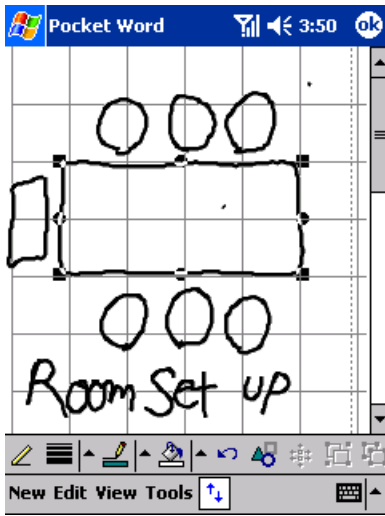

- ▶ Tap  to select formatting options, such as pen weight, line/font color, and fill color.
- ▶ Tap on the drawing to resize an object within the drawing. Drag the selection handles until it is the size you want.
- ▶ Tap and hold on the drawing to display pop-up menu. From the pop-up menu, select **Shape** to convert an object to the proper shape.

Recording Mode

In recording mode, you can embed a recording into your document. Recordings are saved as .wav files. For more information on recording, see “Entering Text Using the Input Panel” on page 54.

For more information on using Pocket Word, tap  and then **Help**.

Pocket Excel

Pocket Excel works with Microsoft® Excel on your computer, providing easy access to copies of spreadsheets. You can also create new spreadsheets on your device or copy spreadsheets from your computer.

- To create a new file, tap , **Programs**, **Pocket Excel**, and then **New**. Or, from the Today screen, tap **New**, and then **ExcelWorkbook**. Only one spreadsheet can be opened at a time; when you open a second you will have to save the first. Spreadsheets can be saved in a variety of formats including Excel (.xls) and Pocket Excel (.pxl).

Pocket Excel contains a list of stored files. Tap a file to open it, and tap and hold to delete, make copies of, or send it from the pop-up menu.

Pocket Excel provides fundamental spreadsheet tools such as formulas, functions, sorting and filtering. To display toolbar, tap **View** and then **Toolbar**.

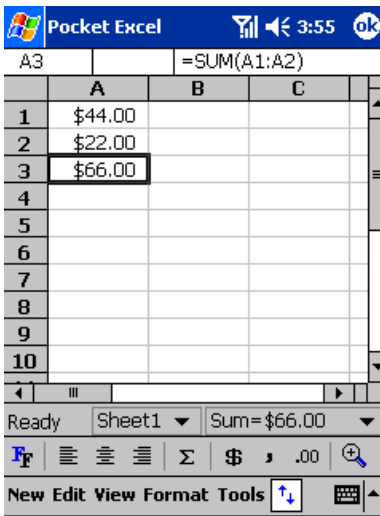

Note: If your spreadsheet contains sensitive information, you can protect it with a password. To do so, open the file, tap **Edit**, and then **Password**. Every time you open that file, you will need to enter the password.

Tips for Working in Pocket Excel

- ▶ To view in full screen mode, tap **View** and then **Full Screen**. Tap **Restore** to exit mode.
- ▶ Tap **View** to select items you want to show or hide.
- ▶ To freeze panes, select the cell(s) you want to freeze, tap **View** and then **Freeze Panes**. Freeze the top and leftmost panes in a spreadsheet to keep row and column labels visible as you scroll through a sheet.
- ▶ To split panes to view different areas of a spreadsheet, tap **View** and then **Split**. Drag the split bar to the desired location. To remove, tap **View** and then **Remove Split**.
- ▶ To hide a row or column, select it and tap **Format, Row or Column**, then **Hide**. To show a hidden row or column tap **Tools**, and then **Go To**, then type a reference that is in the hidden row or column. Then tap **Format, Row or Column**, then **Unhide**.

For more information on using Pocket Excel, tap  and then **Help**.

Windows Media™ Player for Pocket PC

Use Microsoft® Windows Media™ Player for Pocket PC to play digital audio and video files that are stored on your device or on a network.

- To switch to Windows Media™ Player for Pocket PC, tap , then tap **Windows Media**.



Use Microsoft® Windows Media™ Player on your computer to copy digital audio and video files to your device. You can play Windows Media™ and MP3 files (this includes files with the extensions .asf, .wma, .wmv, and .mp3) on your device.

Windows Media™ player can be used even if the screen is turned off.

For more information about using Windows Media™ Player for Pocket PC, Tap , then tap **Help**.

Microsoft® Reader

Microsoft® Reader enables you to read eBooks on your device. Using ActiveSync®, book files can be copied from your computer to your device.

Each book consists of a cover page, an optional table of contents, and the pages of the book. You can:

- ▶ Page through the book by using the cursor button on your device or by tapping the page number on each page.
- ▶ Annotate the book with highlighting, bookmarks, notes, and drawings.
- ▶ Search for text and look up definitions for words.

The Guidebook contains detailed information on using the software. To open, tap **Help** on the Reader command bar. From a book page, tap and hold the book title, then tap **Help** on the pop-up menu.

- To open Microsoft® Reader, tap , **Programs** then **Microsoft Reader**.

Getting Books on Your Device

Download book files from the Web by visiting your favorite eBook retailer and following the directions for downloading.

The Companion CD also includes sample books and a dictionary in the MSReader folder of the APPS folder.

The Read Me file in the EBOOKS folder of the MSReader folder provides directions for using ActiveSync® to download files from your computer.

Using the Library

The Library is your Reader home page. It displays a list of all books stored on your device or storage card.

To open the Library:

- On the Reader command bar, tap **Library**.

—or—

- On a book page, tap the book title, and then tap **Library** on the pop-up menu.

- To open a book, tap its title in the Library list.

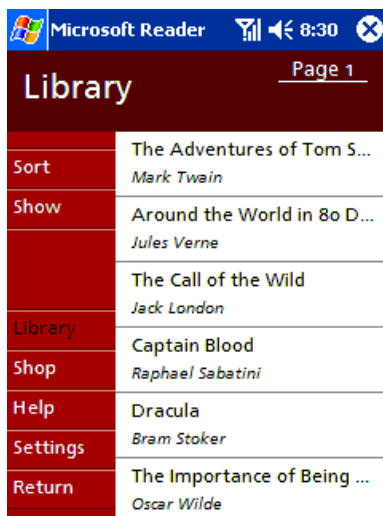

- ▶ Tap **Sort** to select a sort order.
- ▶ Tap **Show** to specify the books you want to display in the list.

Reading a Book

Each book consists of a cover page, an optional table of contents, and the pages of the book. Navigation options are listed in the bottom portion of the cover page.

The first time you open a book, you'll probably want to go to the first page or to the table of contents, if there is one. Subsequently, whenever you open the book, you'll be automatically taken to the last page read.

In addition to the text, each book page includes a page number and book title.

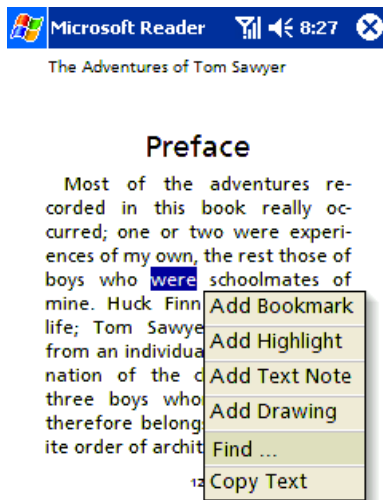

- ▶ Tap on the title at the top of the page to select a navigation option.
- ▶ Tap on the arrows at the bottom of the page to turn the page. You can also tap and hold the page number to bring up the page riffle.
- ▶ Drag cursor over text to select that text and reveal the pop-up menu. Tap on the menu option for the action you want to perform.

You can also page through a book by using the cursor button on your device.

Using Reader Features

Reading an eBook gives you several options not available with paper books.

- Select text by dragging stylus across it and follow options outlined below:
 - ▶ Search for Text: Find text by tapping **Find** on the pop-up menu. Enter your search word and tap the desired **Find** option. Results are highlighted on the page. Tap outside the box to close Find. To return to your original page, tap the title then **Return** on the pop-up menu.
 - ▶ Copy Text: You can copy text from books into any program that accepts text. Select the text you want to copy, then tap **Copy Text** on the pop-up menu. Paste it into the program of your choice.
 - ▶ Bookmarks: When **Add Bookmark** is selected from the pop-up menu, a color-coded bookmark appears in the right margin. Multiple bookmarks can be added, and they can be accessed from anywhere in the book by tapping the bookmark icon.
 - ▶ Highlights: When text is highlighted, it appears with a colored background.
 - ▶ Notes: Enter text in the note that appears on top of the page. To show or hide the note, tap the Note icon displayed in the left margin.
 - ▶ Drawing: When you add a drawing, a Drawing icon appears in the top-right corner of the page along with tools on the bottom of the page.

- ▶ Tap **Go to** then **Annotations** on the book's cover page to see a list of the book's annotations, including bookmarks, highlights, text notes, and drawings. Tapping an entry takes you to the annotated page.

Removing a Book

- When you finish reading a book, it can be deleted (to conserve space) by tapping and holding the title in the Library list, and then tapping **Delete** on the pop-up menu.

Camera

This application allows you to take photographs using the built-in camera. Photographs are saved in the JPEG format. You can adjust parameters such as white balance, brightness, and zoom.

- To switch to Camera, tap , **Programs, Camera**. Or, from the Today Screen, tap , **Camera**.

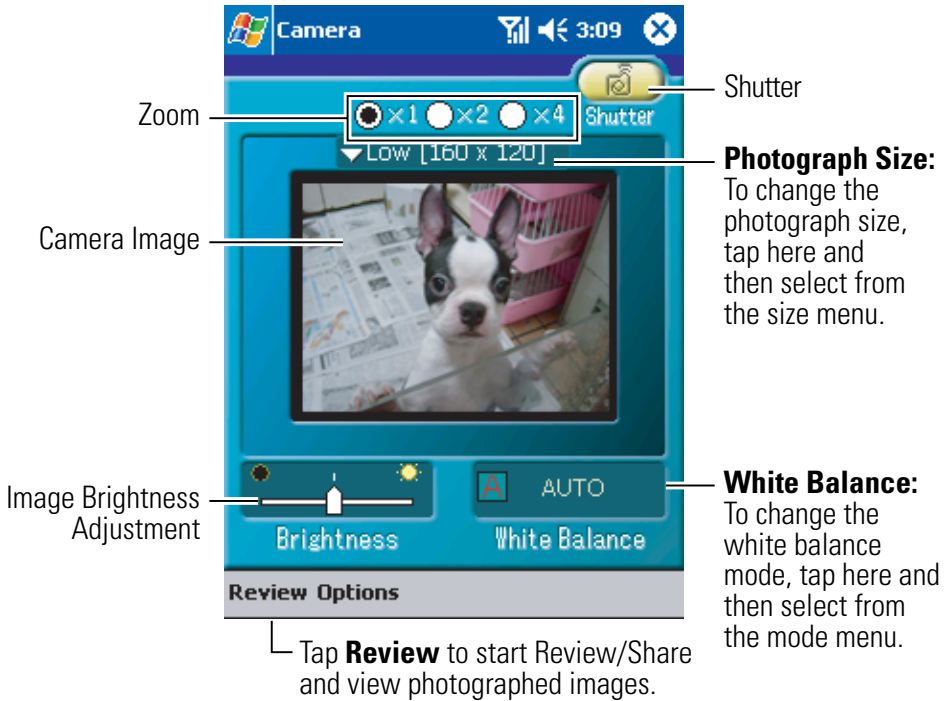

- ▶ Tap the shutter button to take a photograph. Saved photographs are assigned serial numbers and saved in My Documents/Review_Share.

Tip: You can also take a photograph by tapping a space key or pressing the jog wheel.

- ▶ To view saved photographs, tap the Review/Share start icon to start Review/Share.
- ▶ Selectable photograph sizes (in pixels) and zoom ratios
 - High (640 × 480): × 1
 - Middle (320 × 240): × 1, × 2
 - Low (160 × 120): × 1, × 2, × 4

Note: Selectable zoom ratios differ depending on photograph sizes.

▶ Quality

Fine (JPEG compaction ratio: 100%) and Normal (75%) are selectable for quality.

▶ White balance

The following five modes are selectable for white balance:
AUTO, SUNNY, CLOUDY, FLUORESCENT, and TUNGSTEN

Tip: To change quality, tap the **Options** menu, then select **Quality**.

Review/Share

This function allows you to view JPEG images such as those photographed by the camera or downloaded through the Internet. It also permits you to edit images.

Note: Images beyond UXGA cannot be displayed because the memory capacity is exceeded; and the progressive JPEG is not supported.

- To switch to Review/Share, tap , **Programs, Review/Share**. Or, from the Today Screen, tap , **Review/Share**.

Review/Share presents the Thumbnail View and Expand View screens.

Thumbnail View

The Thumbnail screen can display 9 images at a time.

- To enlarge a desired image when in the Thumbnail View mode, tap the image to switch to the Expand View mode.

Tip: To select the Expand View mode, you can also select **Expand picture** from the **Options** menu or press the jog wheel or the Enter key.



Expand View

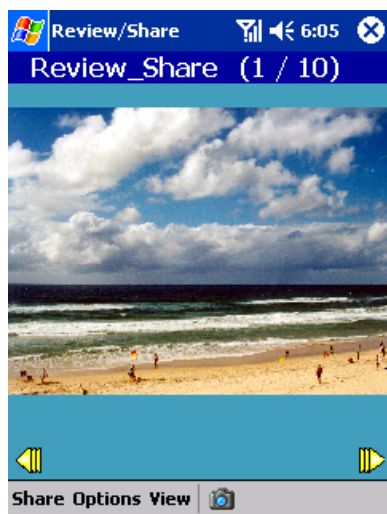

- To switch to the Thumbnail View mode, select **Thumbnail pictures** from the **Options** menu. You can also press the jog wheel or the Enter key instead.

Share Menu

You can share pictures to your family and friends, etc via online server.

- To share pictures, use “**Local Contacts**” or “**Online Phone Book.**”

Options Menu

The Options menu provides the following functions.

- ▶ **Upload:** Uploads pictures to picture server via “Online Pictures” application.
- ▶ **Copy/Move:** Copies, moves, or deletes image files.
- ▶ **Delete:** Deletes image files.
- ▶ **Attach to Contact:** Attaches a specified image to a person selected from the contact list.
- ▶ **Beam Picture:** Sends an image specified with Beam (IrDA) to another device.
- ▶ **Add Voice Memo:** Attaches a voice memo to a specified image.
- ▶ **Edit Caption:** Attaches a caption to a specified image.
- ▶ **Picture Info:** Shows information about a specified image.

- ▶ **Customize Picture:** Allows editing (contrast/ reduce/ rotate/ color) of a specified image.
- ▶ **Folder list:** Changes a folder to be displayed.
- ▶ **Expand picture:** Switches to the Expand View mode.
- ▶ **Thumbnail pictures:** Switches to the Thumbnail View mode.

View Menu

The Tools menu provides the following functions.

- ▶ **Color Mode:** Allows you to select the color from “Normal,” “Black & White,” “Sepia”, and “Negative.”
- ▶ **Slide Show:** Starts slide show when **Start** is selected. To quit slide show, tap the screen. Selecting **Setting** allows you to change the slide show settings.
- ▶ **About:** Shows the application version information.

Online Pictures

This function allows you to share pictures uploaded to the Picture MailSM Website and/or manage pictures and albums (folders).

- To switch to Online Pictures from the Today Screen, tap , **Online Pictures**.

Tip: When connecting to the Picture MailSM Website for the first time, the Enter Password screen appears and prompts you to enter a 4 to 8 characters or digits password for your Picture Mail account. You can use this password to manage your Picture Mail with your PC at www.picturemail.sprintpcs.com.

The Online Pictures screen presents two display modes: Thumbnail View and Expand View.

Thumbnail View

The Thumbnail screen can display 9 images at a time.

- To enlarge a desired image when in the Thumbnail View mode, select **Expand picture** from the **Options** menu or press the jog wheel or the Enter key.

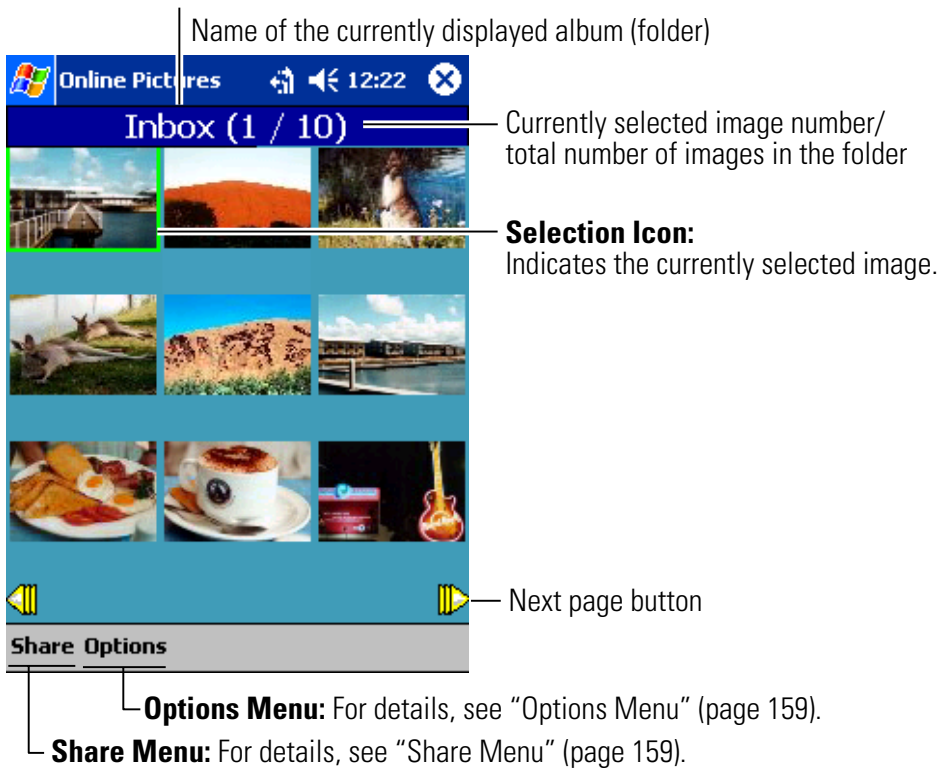

Expand View

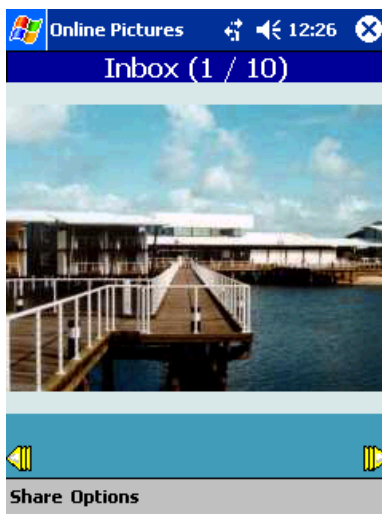

- To switch to the Thumbnail View mode, select **Thumbnail pictures** from the **Options** menu. You can also press the jog wheel or the Enter key instead.

Share Menu

You can share pictures to your family and friends, etc., via the online server.

- To share pictures, use “**Local Contacts**” or “**Online Phone Book.**”

Options Menu

The Options menu provides the following functions.

- ▶ **Copy/Move:** Copies or moves image files.
- ▶ **Save To Review/Share:** Stores image files under the Device’s Review/Share folder.
- ▶ **Delete:** Deletes image files.
- ▶ **Edit Caption:** Attaches a caption to a specified image.
- ▶ **Picture Info:** Shows information about a specified image.
- ▶ **Rotate Picture:** Rotates a specified image.
- ▶ **Create Album:** Creates a new album (folder).
- ▶ **Album List:** Allows you to change an album (folder) to be displayed.
- ▶ **Expand picture:** Switches to the Expand View mode.
- ▶ **Thumbnail pictures:** Switches to the Thumbnail View mode.

ClearVue

This program enables the device to display Microsoft Word, Excel, and PowerPoint files, and Adobe Portable Document Format (PDF) files generated using a personal computer. It is also compatible with a PowerPoint slide show.

Viewing a File

1. To switch to ClearVue, tap , **Programs, ClearVueDocument/ClearVueWorkSheet/ClearVuePresentation/ClearVuePDF** (select a program corresponding to a file to be displayed).
2. Tap **File**, then **Open**. Select a file to be displayed.
3. The content of the file is displayed.

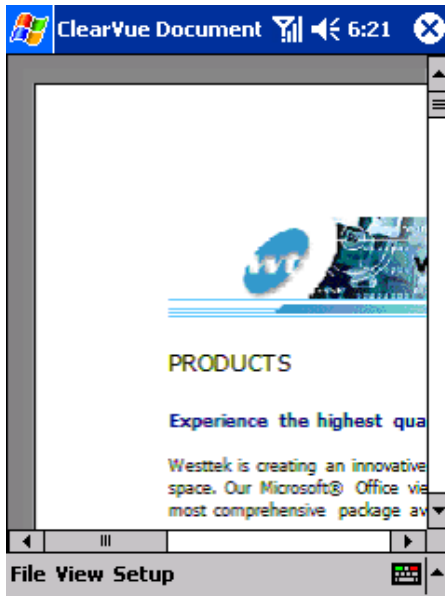

Note: To open a file attached to mail in the Inbox, tap the file. You can also start ClearVue and display a file by tapping a file on File Explorer.

Viewable files

The viewable file formats are as below:

- ▶ Microsoft Word files: Word97/98/2000/2002 (.doc)
- ▶ Microsoft Excel files: Excel97/2000/2002 (.xls)
- ▶ Microsoft PowerPoint files: PowerPoint97/2000/2002 (.ppt)
- ▶ Adobe Portable Document Format files (.pdf)

Note: You cannot view a password protected file.

Note: Some files do not allow included objects such as drawings and graphs to be displayed.

Note: If any fonts specified in the document cannot be displayed, substitute fonts are used.

Note: Some files may present layout distortion.

Note: When opening a large file, quit other applications before starting ClearVue.

World Clock

The current time of four large cities in the world is displayed. The world map roughly shows which regions are currently at daytime or at night.

- To switch to World Clock, tap , **Programs, World Clock.**

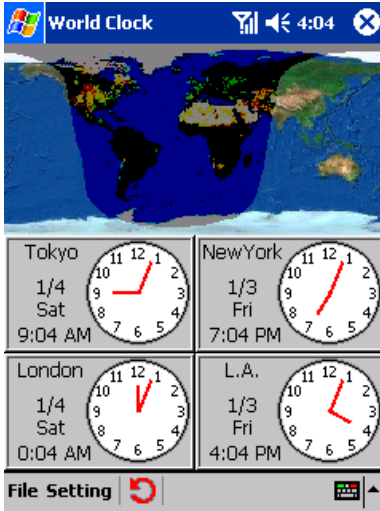

Changing Cities

1. Tap **Setting**, then City.
2. Tap a city from list, then tap **Delete**.
3. Tap **Create**.
4. Tap City to display, then tap **ok**.
5. Select Time format, then tap **ok**.
6. Tap **ok**.

Note: You can program time with **Setting** → **System** → **Clock**.



SaiSuke

SaiSuke allows schedule and task lists to be managed. It synchronizes Pocket Outlook's calendar, tasks, and data. In order to use SaiSuke, install the application program from the supplied Companion CD.

For the method of installing from the Companion CD, see "Installing Application Programs from the Companion CD" on page 164.

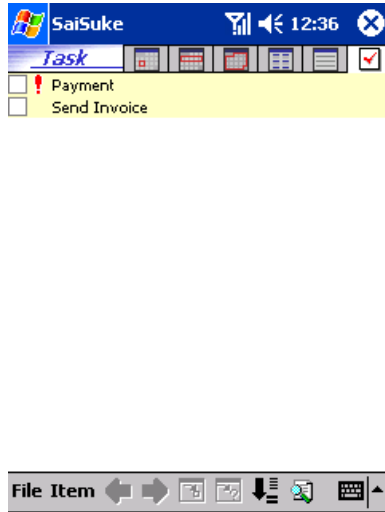
- To access, tap , **Programs, SaiSuke.**



- Tap , , , ,  or  to select from six views (Day, Week, Month, Year, Agenda, and Tasks).

Creating an Appointment

1. Tap **Item, New**, then **Appointment**.
2. Enter Subject and Location, then select Time.
3. Select other settings as necessary.
4. Tap **ok**.

Creating a Task

1. Tap **Item, New**, then **Tasks**.
2. Enter Subject and select priority.
3. Select other settings as necessary.
4. Tap **ok**.

Installing Application Programs from the Companion CD

The supplied Companion CD contains several application programs. In order to use these programs, install them onto the device using the following procedure:

1. Connect the device to a personal computer.
 - ▶ For details, see “Connecting with a Personal Computer” on page 173.
2. Insert the Companion CD into the CD-ROM drive.
 - ▶ The main menu screen appears.
3. Select Enhance Your Pocket PC, select an index name shown at the left of the screen, and then click Install for the application program to be installed.
 - ▶ Follow the on-screen instructions to install the program.

Note: When you have installed such an application program that always results in entire top screen display, a popup menu may not appear or a ringer may not be generated. Operations with application programs other than the supplied ones shall not be assured.

Section 2J

Getting Connected

In This Section

- ▶ **Sending Files Using Infrared Rays**
 - ▶ **Connecting to the Internet Using PCS Connection**
 - ▶ **Restoring the PCS Vision Connection**
 - ▶ **Disconnecting from the Internet Using PCS Connection**
 - ▶ **Connecting to the PCS e-Mail Server**
 - ▶ **Connecting Directly to an Email Server**
 - ▶ **Get Help on Connecting**
-

This section describes how to use infrared (IR) to exchange information with other mobile devices, how to connect to and disconnect from the Internet using PCS Connection, and how to directly connect to an email server.

Your device can exchange information with other mobile devices as well as your computer, a network, or the Internet. The connection options include the following:

- ▶ The device's infrared (IR) port can send files to and receive files from another device. See "Sending Files Using Infrared Rays" below for more information.
- ▶ When connected to the Internet via PCS Connection, you can send and receive email by using Inbox and view Web and WAP pages using Pocket Internet Explorer.
- ▶ Remotely connect to your computer to synchronize information such as Pocket Outlook®. See ActiveSync® Help on your computer or Connection Help on your device for more information.

Sending Files Using Infrared Rays

This device allows data communications using infrared rays with a device (such as a pocket PC) having an infrared ray port.

Sending and Receiving Data

1. Position this device and the other device so that their respective infrared ray ports face each other.

Note: The two ports should be close together, and no obstacle should exist between the ports. For details, see "Using the Infrared Communications Port" on page 33.

2. On File Explorer on the sending device, tap and hold a file or item to be sent. A pop-up menu appears.
3. Tap **Beam File...** on the pop-up menu. "Receiving Data" appears on the receiving device.
4. On the receiving device, tap **Yes**. The data transfer is executed.

Note: In addition to using File Explorer, you can also select **Beam File...** from the pop-up menu using the program list screen.

Connecting to the Internet Using PCS Connection

For the applications installed on the device, automatic connections can be performed. (If connections fail, see “Restoring the PCS Vision Connection” on page 168 and restore the connection settings.)

Note: Before connecting, you activate the phone and perform provisioning. For more information, see page 46.

In order to perform manual connections, perform the following operations:

1. Tap , then **Settings**. On the **Connections** tab, tap **Connections**.

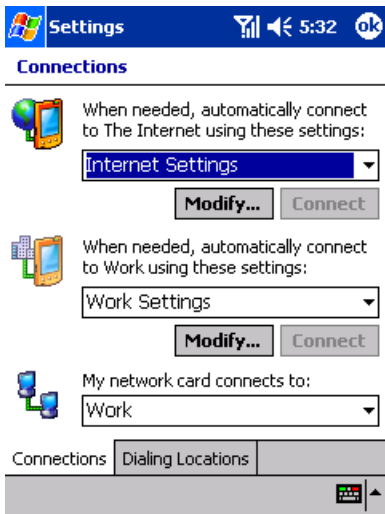

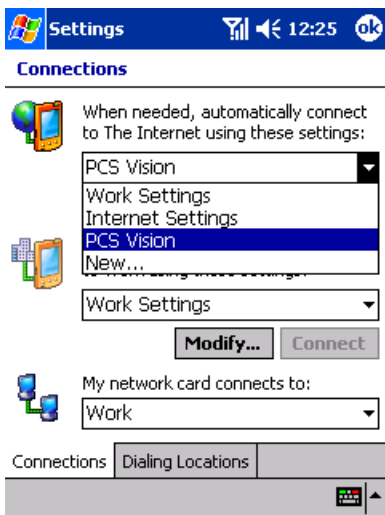

2. Tap  at the right end of Internet Connection, and then select **PCS Vision** from the displayed list.



3. Tap **Connect** under PCS Vision.

After the Connecting bubble window is displayed, connection to the Internet is executed.

▶ The  icon appears during an Internet connection.

Tip: Applications that need to connect to the Internet, such as Pocket Internet Explorer, automatically connect to the Internet as necessary. When an Internet connection is started, the Connecting bubble window appears. On the navigation bar, the  icon appears during an Internet connection.

Note: The setting becomes effective after resetting is executed.



Restoring the PCS Vision Connection

If you have altered or deleted the PCS Vision Connection, you can restore it using the following procedure:

Tap  , then **Settings**. On the **Connections** tab, tap **PCS Vision Recovery**.

▶ For the subsequent steps, follow the on-screen instructions.

Disconnecting from the Internet Using PCS Connection

1. Tap the  icon on the navigation bar.
 2. Tap **End** on the Connecting bubble window.
- ▶ The  icon disappears and disconnection from the Internet is executed.

Connecting to the PCS e-Mail Server

Making PCS e-Mail Setting

1. Tap , then **Settings**. On the **Connections** tab, tap **PCS Mail Setting**.



2. With a confirmation message displayed, tap **Yes**.

Note: The power of the Phone needs to be kept on.

Connecting to the PCS e-Mail Server

1. Tap , then **Inbox**.

2. Tap **Services** menu, confirm that the box beside PCS Mail has been checked, and then tap **Connect**.

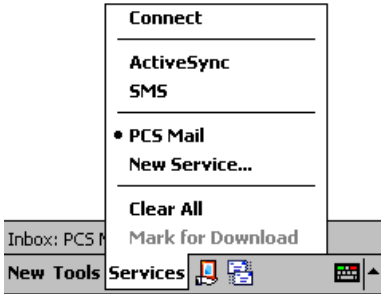

3. With a password confirmation screen displayed, enter a Mail Password, and then tap **ok**.

Note: You need to set a Mail Password in advance by logging in the Sprint PCS's website.

4. The PCS e-Mail server is connected and mail transfer is performed.

Tip: For more information on using the Inbox program, see "Inbox: Sending and Receiving Email Messages" on page 134".

Connecting Directly to an Email Server

You can set up a connection to an email server so that you can send and receive email messages by using a modem and Inbox on your device.

Note: The ISP or network must use a POP3 or IMAP4 email server and an SMTP server. You can use multiple email services to receive messages. For each email address you intend to use, set up and name the email service following the directions below.

To set up an email service:

- In Inbox on your device, tap **Services**, then **New Service**. Follow the directions in the New Service wizard.

For an explanation of a screen, tap  then **Help**. When finished, to connect to your email server, tap **Services** then **Connect**. For more information on using the Inbox program, see “Inbox: Sending and Receiving Email Messages” on page 134.

Get Help on Connecting

Additional help and information can be found in the following locations:

- ▶ “Inbox: Sending and Receiving Email Messages” on page 134.
- ▶ Online Help on the device. Tap  then **Help**. Tap **View**, **All Installed Help**, then **Inbox** or **Connections**.
- ▶ ActiveSync® Help on the computer. In ActiveSync®, click **Microsoft ActiveSync Help** on the **Help** menu.
- ▶ For troubleshooting information, see the Pocket PC Website at: <http://www.microsoft.com/mobile/pocketpc>.

Section 2K

Connecting with a Personal Computer

In This Section

► **Using Microsoft® ActiveSync®**

This section describes the procedures for using Microsoft® ActiveSync®. This application allows Microsoft Outlook® data on a connected personal computer to be synchronized with the data on the device.

Using Microsoft® ActiveSync®

Using Microsoft® ActiveSync®, you can synchronize the information on your computer with the information on your device. Synchronization compares the data on your device with your computer and updates both computers with the most recent information. For example:

- ▶ Keep Pocket Outlook® data up-to-date by synchronizing your device with Microsoft® Outlook® data on your computer.
- ▶ Synchronize Microsoft® Word and Microsoft® Excel files between your device and computer. Your files are automatically converted to the correct format.

Note: Use ActiveSync options to turn synchronization on and off for specific information types.

With ActiveSync, you can also:

- ▶ Back up and restore your device data.
- ▶ Copy (rather than synchronize) files between your device and computer.
- ▶ Control when synchronization occurs by selecting a synchronization mode. For example, you can synchronize continually while connected to your computer or only when you choose the synchronize command.
- ▶ Select which information types are synchronized and control how much data is synchronized. For example, you can choose how many weeks of past appointments you want synchronized.

Before you begin synchronization, install ActiveSync® on your computer from the Companion CD. ActiveSync® is already installed on your device.

Installing ActiveSync on a Personal Computer

Note: ActiveSync can run under the following environments.

Minimum Desktop Computer Requirements

- Microsoft Windows XP, Windows 2000, Windows Millennium Edition, or Windows 98 Second Edition
 - Microsoft Outlook 98 or later required for synchronization to the desktop or portable computer of email, calendar, contacts, tasks, and notes. (Outlook 2002 recommended)
 - Microsoft Internet Explorer 4.01 SP1 or later
 - Hard-disk drive with 12 to 65 MB of available hard-disk space (actual requirements will vary based on selection of features and user's current system configuration)
 - USB port
 - One CD-ROM drive
 - VGA graphics card or compatible video graphics adapter at 256 color or later
 - Keyboard
 - Microsoft Mouse or compatible input device
-

1. Insert the Companion CD into the CD-ROM drive. A setup window appears.
 2. Click **Start Here**.
 3. To install ActiveSync®, click **Install ActiveSync 3.7**, and then follow the subsequent on-screen instructions.
-

Note: When the File Download screen displays, select **Run this program from its current location** and click **OK**. Or when the message, "Would you like to open the file or save it to your computer?" displays on Windows XP, click **Open**.

Note: When the Security Warning screen displays, click **Yes**.

- ▶ When the installation is completed, the Get Connected window appears.

ActiveSync installation has been completed.

Connecting With a Personal Computer

1. Confirm that the Get Connected window is displayed on the personal computer.

Note: If Get Connected window is not displayed, double-click the Microsoft ActiveSync icon on the desktop to start ActiveSync.

2. Connect the USB cradle to the USB port on the personal computer. For details, see “Using the USB Port” on page 32.

Note: Do not mount the device onto the cradle yet. Connect the AC adapter to the USB cradle and plug the adapter into a wall outlet.

3. Mount the device onto the USB cradle. For details, see “Using the USB Port” on page 32.

- ▶ The connection between the device and the personal computer is established.

Note: When the device is detected and the “Add New Hardware Wizard” screen displays, follow the screen to install the driver. The driver exists on the Companion CD root directory. When required, specify the drive into which the Companion CD is inserted.

4. The Set Up a Partnership screen appears. Follow the instructions on the screen to finish setup.

Note: If the connection between the phone and the computer is lost, briefly remove the phone from the cradle then replace it.

Note: For more information on the connection to your device or other settings, please see the Help option in ActiveSync®.

After your first synchronization, take a look at Calendar, Contacts, and Tasks on your device. You’ll notice that information you’ve stored in Microsoft Outlook on your computer has been copied to your device, and you didn’t have to type a word. Disconnect your device from your computer and you’re ready to go.

Once you have set up ActiveSync and completed the first synchronization process, you can initiate synchronization from your device. To switch to ActiveSync on your device, tap , and then tap **ActiveSync**.

For information about using ActiveSync on your computer, start ActiveSync on your computer, and then see ActiveSync Help.

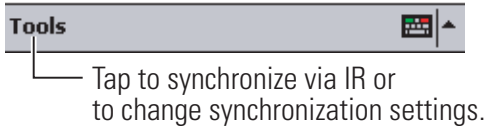
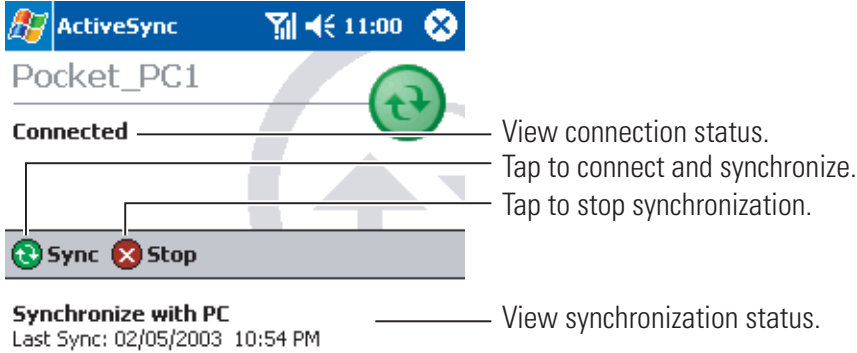

For more information about ActiveSync on your device, switch to ActiveSync, tap , and then tap **Help**.

Section 2L

Backing Up Data

In This Section

- ▶ **Backing Up Data Using a Personal Computer**
 - ▶ **Backing Up Data Using a Memory Card**
-

Files stored on storage memory and mail data in the Inbox will be lost if the built-in battery becomes empty. You therefore should regularly back up important data using a personal computer or a memory card.

Backing Up Data Using a Personal Computer

Backup Procedure

Use the following procedure to back up data using a personal computer. Note that the dates, time, and passwords will not be backed up.

1. Connect the device to a personal computer. For the connection method, see “Using the USB Port” on page 32.
2. Start Microsoft ActiveSync on the personal computer. Then select **Backup/Restore** under the **Tools** menu.
3. Select **Full backup**.

Note: Select **Incremental backup** at the time of the second and subsequent backups. If you want backup to be automatically performed when the device is connected to the personal computer, select **Automatically backup each time the device connects**.

4. If you want to change the folder for backing up, click **Change**.

Note: A backup file is generated on the personal computer. Because this file needs to be specified at the time of restoration, be careful to note its location.

5. Click **Back Up Now**.
6. Click **OK**.

Note: Do not operate the device until the backup is completed.

Tip: To conserve battery strength, it is recommended to use the AC adapter when executing data backup.

Restoration Procedure

Before performing restoration, quit all open applications.

1. Initialize the device. For the initialization method, see “Initialization” on page 26.
2. Connect the device to the personal computer. For the connection method, see “Using the USB Port” on page 32.

3. Start Microsoft ActiveSync on the personal computer. Then select **Backup/Restore** under the **Tools** menu.
4. Select the **Restore** tab.
5. Click **Restore Now**.
6. Follow the on-screen instructions to select an appropriate corresponding file (partnership file).
7. Click **Restore**.
 - ▶ The restoration progress status is indicated. Do not operate the device until the restoration is completed.
8. When a restoration finish message appears, click **OK** to reset the device. For the resetting method, see “Resetting” on page 25.

Note: Do not operate the device until the restoration is completed.

Tip: To conserve battery strength, it is recommended to use the AC adapter when executing data restoration.

Backing Up Data Using a Memory Card

Backup Procedure

Use the following procedure to back up data using a memory card. Note that the dates, time, passwords, calibration data, and partnership data with a personal computer will not be backed up.

1. Quit all applications, and then insert a memory card into the device.
See “Using SD Card / MultiMediaCard” on page 34 for details.
2. Tap , **Programs**, and **Data Backup**.
3. Select **Backup**, then tap **Next**.

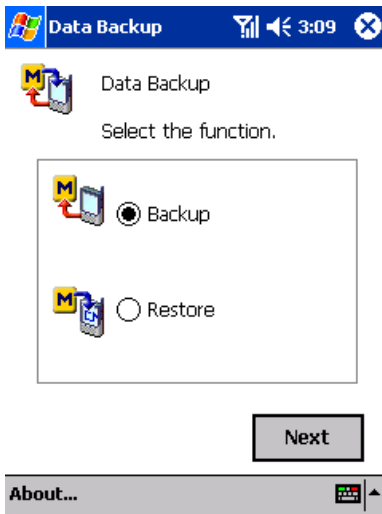

4. Select a folder for backing up, then tap **Start**.

▶ You may tap **Browse...** to select a folder from a list.

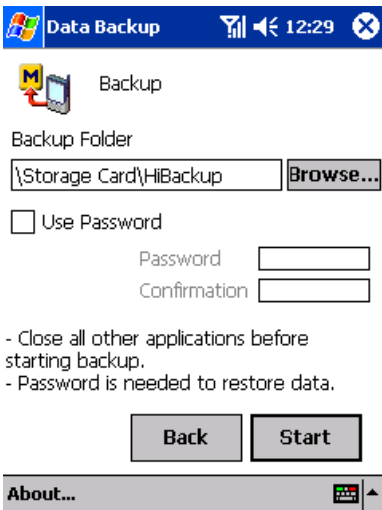

Note: When backing up data using the same medium again, specify the same folder name. If you select a folder not generated for backing up, all data in the folder will be lost.

Note: If you check the box for **Use Password**, backed up data cannot be restored unless a correct password is entered. A password can be composed of 1 to 8 digits. You can enter A to Z, a to z, and 0 to 9.

5. After a confirmation message appears, tap **Yes** to start data backup.

Note: Do not operate the device until backup is completed.

Tip: To conserve battery strength, it is recommended to use the AC adapter when executing data backup.

Note: Use a memory card that has about twice as much capacity as the in-use area size of the data storage area.

Restoration Procedure

1. Initialize the device. For the initialization method, see “Initialization” on page 26.
2. Insert a memory card containing backup data into the device, and then switch the device on.
3. Tap , **Programs**, and **Data Backup**.
4. Select **Restore**, then tap **Next**.

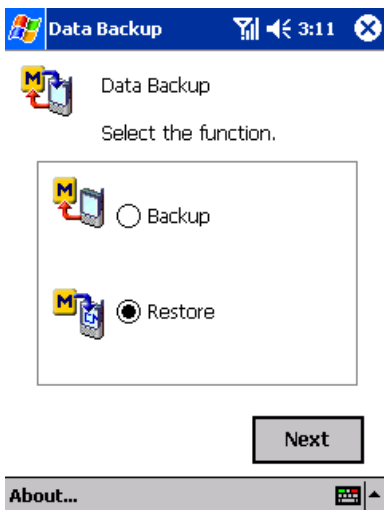

5. Select a folder containing backed up data, then tap **Start**.

▶ You may tap **Browse...** to select a folder from a list.

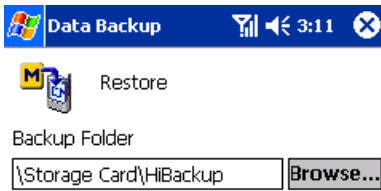

- Start restore under the full reset states.

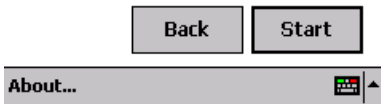

6. After a confirmation message appears, tap **Yes**.

▶ If a password has been programmed, enter a correct password.

Note: Do not operate the device until the restoration is completed.

Tip: To conserve battery strength, it is recommended to use the AC adapter when executing data restoration.

7. After a restoration finish message appears, reset the device. For the resetting method, see “Resetting” on page 25.

Note: When using ActiveSync after restoration using a memory card, make sure to select **Delete Partnership** under the **File** menu on the PC. Connecting a computer to the restored device causes New Partnership dialog box to appear. Set a new relationship in this box.

Using PCS Service Features

Section 3A

PCS Service Features: The Basics

In This Section

- ▶ **Using Voicemail**
 - ▶ **Using Caller ID**
 - ▶ **Responding to Call Waiting**
 - ▶ **Three-Way Calling**
 - ▶ **Using Call Forwarding**
-



Now that you've mastered your phone's fundamentals, it's time to explore the calling features that enhance your PCS Service.

Using Voicemail

Setting Up Your Voicemail

All unanswered calls to your PCS Phone are automatically transferred to voicemail, even if your phone is in use or turned off. Therefore, you will want to set up your PCS Voicemail and personal greeting as soon as your phone is activated.

To set up voicemail:

1. Make sure the phone is on. See “Turning the Phone ON and OFF” on page 72 for details.
2. If the dialer screen is not displayed, activate the dialer screen by pressing  on the device.
3. Tap and hold .
4. Follow the system prompts to create your pass code, record your greeting, record your name announcement and choose whether to activate One-Touch Message Access (a feature that lets you tap one key to access messages and bypasses the need for you to enter your pass code).

Note: The voicemail setup process may vary in certain Affiliate areas.

Voicemail Notification

There are several ways your PCS Phone alerts you to new voicemail messages:

- ▶ By displaying a message on the screen
- ▶ By playing the assigned ringer type
- ▶ By flashing LED
- ▶ By displaying  at the top of display screen

New Voicemail Message Alerts

- When you receive a new voicemail message, your device alerts you and prompts you to call your voicemail. To call your voicemail, tap **Voice Mail**.

Important: When you are roaming off the Sprint Nationwide PCS Network, you may not receive notification of new voicemail messages. It is recommended that you periodically check your voicemail by dialing 1 + area code + your PCS Phone number. When your voicemail answers, tap ***** and enter your pass code. You will be charged roaming rates when accessing voicemail while roaming off the Sprint Nationwide PCS Network.

Note: Your device accepts messages even when it is turned off. However, you are only notified of new messages when your phone is turned on and you are in a PCS Service Area.

Retrieving Your Voicemail Messages

You can review your messages directly from your PCS Phone or from any other touch-tone phone. To dial from your PCS Phone, you can either speed dial your voicemail or use the Menu keys.

Using One-Touch Message Access

- Tap and hold **1**. Follow the system prompts.

Using the Menu on Your PCS Phone to Access Your Messages

- Tap **Tools**, then **Voice Mail**.

Tip: You are charged for airtime minutes when you are accessing your voicemail from your PCS Phone.

Using a Phone Other Than Your PCS Phone to Access Your Messages

1. Dial your PCS Phone number.
2. When your voicemail answers, tap *****.
3. Enter your pass code.

Voicemail Options

Your PCS Phone offers several options for organizing and accessing your voicemail.

Setting Up Group Distribution Lists

Create up to 20 separate group lists, each with up to 20 customers.

1. Tap and hold **1** to access your voicemail.
2. Following the system prompts, tap **3** to change your Personal Options.
3. Tap **2** for Administrative Options.
4. Tap **5** for Group Distribution Lists.
5. Follow the voice prompts to create, edit, rename or delete group lists.

PCS Callback

Return a call after listening to a message without disconnecting from voicemail.

1. After listening to a message, tap **8**.
2. Follow the voice prompts to enter the phone number.
3. Once the call is complete, you're returned to the voicemail main menu.

Voicemail-to-Voicemail Message

Record and send a voice message to other PCS Voicemail customers.

1. From the main voicemail menu, tap **2** to send a message.
2. Follow the voice prompts to enter the phone number.
3. Follow the voice prompts to record and send your voice message.

Voicemail-to-Voicemail Message Reply

Reply to a voice message received from any other PCS Voicemail customer.

1. After listening to a voice message, tap **2**.
2. Follow the voice prompts to record and send your reply.

Voicemail-to-Voicemail Message Forwarding

Forward a voice message, except those marked “Private,” to other PCS Voicemail customers.

1. After listening to a message, tap **6**.
2. Follow the voice prompts to enter the phone number.
3. Follow the voice prompts to record your introduction and forward the voice message.

Voicemail-to-Voicemail Receipt Request

Receive confirmation that your voice message has been listened to when you send, forward, or reply to a message to other PCS customers.

1. After you have recorded a message, tap **1** to indicate you are satisfied with the message you recorded.
2. Tap **4** to mark receipt requested.
3. Tap **1** to send your voicemail message.

Continue Recording

- Before tapping **1** to indicate you are satisfied with the message you recorded, tap **4** to continue recording.

Extended Absence Greeting





When your phone is turned off or you are off the Sprint Nationwide PCS Network for an extended period, this greeting can be played instead of your normal personal greeting.

1. From the main voicemail menu, tap **3** for Personal Options.
2. Tap **3** for Greetings.
3. Tap **3** to record an Extended Absence Greeting.

Using Caller ID

Caller ID lets you know who's calling by displaying the number of the person calling when your device rings. Similarly, if you call someone who has this feature, your phone number displays on their phone. If the caller's name and number are already stored in your Internal Phone Book, the corresponding name appears with the number.

To block your phone number from being displayed for a specific outgoing call:

1. Tap   .
2. Enter the number you want to call.
3. Tap .

To permanently block your number, call PCS Customer Solutions.

Responding to Call Waiting

When you're on the phone and another call is received, the screen displays an incoming bubble message.

- Press  or tap **Answer**.

This step puts the first caller on hold and answers the second call.





To switch back to the first caller:

- Tap  again.

Tip: For those calls where you don't want to be interrupted, you can temporarily disable Call Waiting by tapping before placing your call. Call Waiting is automatically reactivated once you end the call.

Three-Way Calling

With Three-Way Calling, you can talk to two people at the same time. When using this feature, the normal airtime rates will be charged for each of the two calls.

1. Enter a number you wish to call and tap .
2. Once you have established the connection, tap  to put the first caller on hold.
3. Dial the second number you wish to call.
 - ▶ You can also select a phone number from your Internal Phone Book or Call History.
4. Tap .
5. When you're connected to the second party, tap  once more to begin your three-way call.





If one of the people you called hangs up during your call, you and the remaining caller stay connected. If you initiated the call and are the first to hang up, all three callers are disconnected.

Note: Call Waiting and Three-Way Calling are not available while roaming off the Sprint Nationwide PCS Network.





Using Call Forwarding

Call Forwarding lets you forward all your incoming calls to another phone number – even when your phone is turned off. You can continue to make calls from your phone with Call Forwarding activated.

To Activate Call Forwarding:

1. Tap   .
2. Enter the area code and phone number to which your future calls should be forwarded.
3. Tap . You will hear a tone to confirm the activation of Call Forwarding.

To Deactivate Call Forwarding:

1. Tap    .
2. Tap . You will hear a tone to confirm the deactivation.

Note: You are charged a higher rate for calls you have forwarded.

Section 3B

PCS VisionSM

In This Section

- ▶ **PCS Business ConnectionSM Personal Edition**
 - ▶ **Web**
 - ▶ **Picture MailSM**
 - ▶ **Messaging**
 - ▶ **PCS Vision FAQs**
-

PCS VisionSM brings you clarity you can see and hear, with enhanced, always-on mobile multimedia capabilities like email and pictures that are easy to learn and use. This rich, colorful graphic experience is visually comparable to your home or office computer. It's a revolutionary way to look at wireless.



PCS Business ConnectionSM Personal Edition

PCS Business ConnectionSM Personal Edition is designed to offer secure wireless access to both Microsoft Outlook and Lotus Notes.

PCS Business Connection Personal Edition delivers the following features:

- ▶ **Business email access:** Read, reply to, forward, delete, and compose your company email.
- ▶ **Company directory and contacts:** Search, view, call, and email contacts from your company's directory. Do all this and add/edit your personal contacts.
- ▶ **Work calendar:** Accept and reject meeting and, view daily summaries and details, and navigate to various dates.
- ▶ **Files/information on your PC:** Browse folders and download and view documents from any device using a PC browser or Pocket Internet Explorer.

To use PCS Business Connection Personal Edition, install Business Connection Personal Edition software on your work PC. This allows data to be securely retrieved in real-time by your wireless device when connected to the Sprint Nationwide PCS Network. There is a monthly charge for PCS Business Connection, and usage charges will also apply.

When your work PC isn't on, you can share connections with your co-workers so that you always have access to your email, calendar, and contacts. Your data remains secure behind the corporate firewall and, any changes you make on your wireless device are instantly updated on your corporate server without the need to synchronize.

Additional Business Connection solutions are available to your company. For more details, visit businessconnection.sprintpcs.com.



Web

Experience full-color graphic versions of popular Websites.

Browsing the Web

For details of the application for browsing the Web, see the following:

- ▶ Pocket Internet Explorer (page 130) – Use Microsoft Pocket Internet Explorer to view Web or WAP pages.



Picture MailSM

Take digital pictures with a built-in camera and send them to computers or other PCS Vision Phones.

Taking Pictures

1. Tap  and then **Camera** from the Today Screen to activate Camera.
2. Using the main LCD as a viewfinder, aim the camera at your subject.
3. Tap the shutter button in the screen to take the picture. The picture you take will be saved automatically.
4. To take another picture, tap the shutter button.

Viewing Pictures

1. To view saved pictures, tap **Review** in Camera. You can also access **Review/Share** from  on the Today Screen.
2. You will see the pictures you have saved.

Uploading Pictures to the Picture MailSM Website

1. Using Review/Share, specify a picture to be uploaded, and then in the **Options** menu, tap **Upload** then **Upload this picture**.

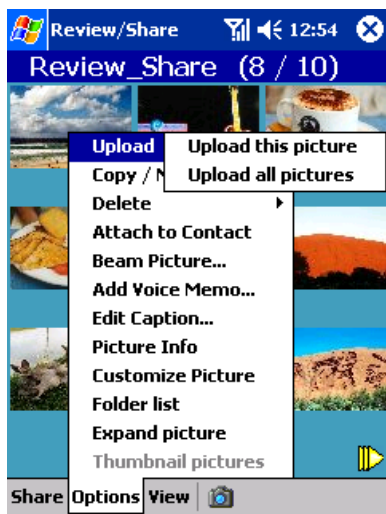

2. The Picture MailSM Website is connected and uploading of the image is started.

The following screen appears when uploading is completed.

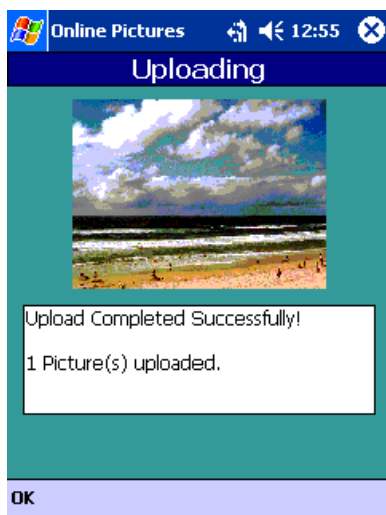

Tip: When connecting to the Picture MailSM Website for the first time, the Enter Password screen appears and prompts you to enter a 4 to 8 characters or digits password for your Picture Mail account. You can use this password to manage your Picture Mail with your PC at www.picturemail.sprintpcs.com.

Sharing Pictures

1. Using Review/Share, specify a picture to be shared, and then in the **Share** menu, tap **Local Contacts**.



Tip: To use the Online Phone Book on the Picture MailSM Website, tap **Online Phone Book** in the **Share** menu.

2. In the contact list, check for the recipient with whom the picture is to be shared, and then tap **Next**.

Tip: To share with a recipient not registered, tap **New Entry**, and register in the contact list, and then perform checking.



3. On the Enter Message screen, register text and voice messages for the recipient, and then tap **Next**.
4. Check the content on the Preview screen, and then tap **Send**.

5. The Picture MailSM Website is connected and the Picture Share processing is started.

The following screen appears when the Picture Share processing is completed.

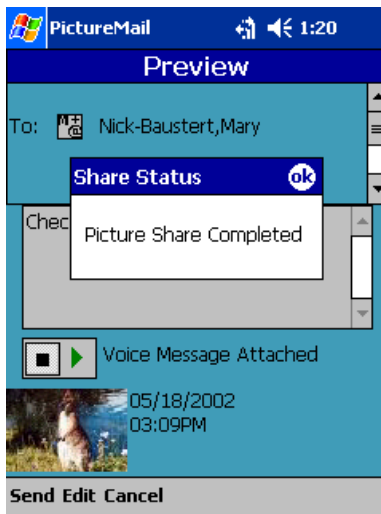

Tip: When the Picture Share processing is completed, the recipient is informed through SMS or email.

For details of the Picture MailSM application, see the following:

- ▶ Camera (page 153) – This application allows you to take photographs using the built-in camera. Taken photographs are saved in the JPEG format. You can adjust parameters such as white balance, brightness, and zoom.
- ▶ Review/Share (page 155) – This application can display JPEG images. The images are taken by the built-in camera and are downloaded from Internet, and so on.
- ▶ Online Pictures (page 157) – This application allows you to share pictures uploaded to the Picture MailSM Website and/or manage pictures and albums (folders).



Messaging

Send and receive email and text messages or chat.

For details of the application for Messaging, see the following:

- ▶ Inbox (page 134) – Use Inbox to send and receive email messages.
- ▶ MSN Messenger (page 139) – MSN Messenger on your mobile device is an instant messaging program.

PCS Vision FAQs

How will I know when my device is ready for PCS Vision Service?

Your user name (for example, bsmith001@sprintpcs.com) will display on your device's display screen.

How do I know when my device is connected to PCS Vision Services?

Your device automatically connects when PCS Vision Service is used or an incoming message arrives. (Connecting takes about 10-12 seconds.)

Can I make calls and use PCS Vision Services at the same time?

You cannot use voice and data services simultaneously. If you receive a call while the data service is active, the call will be forwarded into voicemail. You can place an outgoing call at any time, but it will interrupt any in-progress data session.

When is my data connection active?

Your connection is active when data is being transferred. Outgoing calls are allowed, but incoming calls go directly to voicemail.

When is my data connection dormant?

If no data is received for 10 seconds, the connection goes dormant. When the connection is dormant, voice calls are allowed. (The connection can go active again quickly.) If no data is received for a long time, the connection will terminate.

Section 3C

PCS Voice CommandSM

In This Section

- ▶ **Getting Started With PCS Voice Command**
 - ▶ **Creating Your Own Address Book**
 - ▶ **Making a Call With PCS Voice Command**
 - ▶ **Accessing Information Using PCS Voice Command**
-



With Sprint, the first wireless provider to offer innovative PCS Voice Command technology, reaching your friends, family, co-workers, and teammates has never been easier – especially when you're on the go. You can even listen to Web-based information such as news, stock quotes, weather, sports, and much more. Your voice does it all with PCS Voice Command.

Getting Started With PCS Voice Command

With PCS Voice Command:

- ▶ You can store all your contact's phone numbers, so you can simply say the name of the person you want to call.
- ▶ There's no need to punch in a lot of numbers, memorize voicemail passwords, or try to dial while you're driving.
- ▶ You can call anyone in your address book – even if you don't remember their phone number.



It's Easy to Get Started

- Just dial   from your PCS Phone to activate the service and listen to brief instructions directly from your device. There is a monthly charge for PCS Voice Command.

Creating Your Own Address Book



You can program up to 500 names into your personal address book, with each name having up to five phone numbers. That's 2,500 phone numbers – and with the advanced technology of PCS Voice Command, you can have instant access to all of them.

There are four ways to update your address book:

- ▶ **Use Voice Recordings:** Simply dial   and say, “Add name.” You will then be asked to say the name and number you want to add to your personal address book. Your address book can store up to 20 voice recorded names at once.
- ▶ **On the Web:** Go to www.talk.sprintpcs.com and receive a fully functional Web-based address book to create and update your contacts.
- ▶ **Use an Existing Address Book:** Automatically merge address books from desktop software applications with Sprint SyncSM Services for no additional charge. Simply click on the “Click to synchronize” button within your PCS Voice Command personal address book at www.talk.sprintpcs.com.



- ▶ **Call Directory Assistance:** If you don't have a computer or Internet access handy, you can have PCS Directory Assistance look up phone numbers for you and automatically add them to your address book. Just say, "Call operator," and we'll add two names and numbers to your address book for our standard directory assistance charge.

Making a Call With PCS Voice Command

1. Once you've signed up for PCS Voice Command and created your address book, all you do is tap  . You'll hear a tone followed by the prompt "Ready."
2. After the "Ready" prompt, simply say, in a natural voice, "Call" and the name of the person or the number you'd like to call. For example, you can say, "Call Jane Smith at work," "Call John Baker on the mobile phone," "Call 555-1234," or "Call Bob Miller."
3. Your request will be repeated and you will be asked to verify. Say "Yes" to call the number or person. Say "No" if you wish to cancel.
4. The number will automatically be dialed. Keep in mind that PCS Voice Command recognizes not only your voice, but any voice, so that others can experience the same convenience if they use your device.

For more helpful hints on PCS Voice Command, including a list of recognized commands and an interactive tutorial, visit www.talk.sprintpcs.com.

Accessing Information Using PCS Voice Command

1. Tap  .
2. Say "Call the Web." (To access, listen to and respond to email, once email has been set up, say "Call My Email.")
3. Choose from a listing of information categories like news, weather, sports, and more.

Note: PCS Voice Command is not available while roaming off the Sprint Nationwide PCS Network.

Section 4

Safety Guidelines and Warranty Information

Section 4A

Safety

In This Section

- ▶ **Getting the Most Out of Your Reception**
 - ▶ **Maintaining Safe Use of and Access to Your Device**
 - ▶ **Caring for the Battery**
 - ▶ **Warning**
 - ▶ **Caution**
 - ▶ **Precautions for Use**
 - ▶ **Instructions for Daily Use**
 - ▶ **Acknowledging Special Precautions and the FCC Notice**
 - ▶ **Consumer Information on Wireless Phones**
 - ▶ **Hardware Specifications**
 - ▶ **Owner's Record**
 - ▶ **User Guide Proprietary Notice**
-

Part of getting the most out of your PCS Phone is knowing where and how it works at optimum efficiency. This section outlines performance and safety guidelines that ensure you experience the full quality that your PCS Phone was designed to give you.

Getting the Most Out of Your Reception

Keeping Tabs on Signal Strength

The quality of each call you make or receive depends on the signal strength in your area. Your device informs you of the current signal strength by displaying a number of bars next to the signal strength icon. The more bars displayed, the stronger the signal. If you're inside a building, being near a window may give you better reception.

Understanding the Power Save Feature

If your phone is unable to find a signal after 15 minutes of searching, a Power Save feature is automatically activated. If your phone is active, it periodically rechecks service availability or you can check it yourself by pressing any key. When a signal is found, your phone returns to standby mode.

Understanding How Your Phone Operates

Your phone is basically a radio transmitter and receiver. When it's turned on, it receives and transmits radio frequency (RF) signals. When you use your phone, the system handling your call controls the power level. This power can range from 0.006 watts to 0.341 watts in digital mode.

Knowing Radio Frequency Safety

The design of your device complies with updated NCRP standards described below. To further limit RF exposure, you can limit the duration of your calls and operate your device in the most power-efficient manner. In 1991-92, the Institute of Electrical and Electronics Engineers (IEEE) and the American National Standards Institute (ANSI) joined in updating ANSI's 1982 standard for safety levels with respect to human exposure to RF signals. More than 120 scientists, engineers and physicians from universities, government health agencies and industries developed this updated standard after reviewing the available body of research. In 1993, the Federal Communications Commission (FCC) adopted this updated standard in a regulation. In August 1996, the FCC adopted hybrid standard consisting of the existing ANSI/IEEE standard and the guidelines published by the National Council of Radiation Protections and Measurements (NCRP).

Maintaining Your Phone's Peak Performance

There are several simple guidelines to operating your phone properly and maintaining safe, satisfactory service.

- ▶ Hold the phone over your shoulder when in use.
- ▶ Try not to hold, bend or twist the phone's antenna.
- ▶ Don't use the phone if the antenna is damaged.
- ▶ Speak directly into the microphone.
- ▶ Avoid exposing your device and accessories to rain or liquid spills. If your device does get wet, immediately turn the power off and remove the battery. If it's inoperable, return it to a Sprint Store or call PCS Customer Solutions for service.

Note: For the best care of your device, only Sprint Authorized Personnel should service your device and accessories. Faulty service may void the warranty.

Maintaining Safe Use of and Access to Your Device

FAILURE TO FOLLOW THE INSTRUCTIONS OUTLINED MAY LEAD TO SERIOUS PERSONAL INJURY AND POSSIBLE PROPERTY DAMAGE

Using Your Device While Driving

Talking on your phone while driving (or operating the phone without a hands-free device) is prohibited in some jurisdictions. Laws vary as to specific restrictions. Remember that safety always comes first.

When using your device in the car:

- ▶ Get to know your device and its features, such as speed dial and redial.
- ▶ When available, use a hands-free device.
- ▶ Position your device within easy reach.
- ▶ Let the person you are speaking to know you are driving; if necessary, suspend the call in heavy traffic or hazardous weather conditions.
- ▶ Do not take notes or look up phone numbers while driving.

- ▶ Dial sensibly and assess the traffic; if possible, place calls when stationary or before pulling into traffic.
- ▶ Do not engage in stressful or emotional conversations that may divert your attention from the road.
- ▶ Dial 911 to report serious emergencies. It's free from your wireless phone.
- ▶ Use your phone to help others in emergencies.
- ▶ Call roadside assistance or a special non-emergency wireless number when necessary.

Tip: Purchase an optional Hands-Free Car Kit.

Following Safety Guidelines

To operate your device safely and efficiently, always follow any special regulations in a given area. Turn your device off in areas where use is forbidden or when it may cause interference or danger.

Using Your Device Near Other Electronic Devices

Most modern electronic equipment is shielded from radiofrequency (RF) signals. However, RF signals from wireless phones may affect inadequately shielded electronic equipment.

RF signals may affect improperly installed or inadequately shielded electronic operating systems and/or entertainment systems in motor vehicles. Check with the manufacturer or their representative to determine if these systems are adequately shielded from external RF signals. Also check with the manufacturer regarding any equipment that has been added to your vehicle.

Consult the manufacturer of any personal medical devices, such as pacemakers and hearing aids, to determine if they are adequately shielded from external RF signals.

Note: Always turn off the device in health care facilities and request permission before using the device near medical equipment.

Turning Off Your Phone Before Flying

Turn off your phone before boarding any aircraft. To prevent possible interference with aircraft systems, the U.S. Federal Aviation Administration (FAA) regulations require you to have permission from a crew member to use your device as a phone while the plane is on the ground. To prevent any risk of interference, FCC regulations prohibit using your device as a phone while the plane is in the air.

Turning Off Your Phone in Dangerous Areas

To avoid interfering with blasting operations, turn your phone off when in a blasting area or in other areas with signs indicating two-way radios should be turned off. Construction crews often use remote-control RF devices to set off explosives.

Turn your device off when you're in any area that has a potentially explosive atmosphere. Although it's rare, your device and accessories could generate sparks. Sparks can cause an explosion or fire, resulting in bodily injury or even death. These areas are often, but not always, clearly marked. They include:

- ▶ Fueling areas such as gas stations
- ▶ Below deck on boats
- ▶ Fuel or chemical transfer or storage facilities
- ▶ Areas where the air contains chemicals or particles such as grain, dust or metal powders
- ▶ Any other area where you would normally be advised to turn off your vehicle's engine

Note: Never transport or store flammable gas, liquid, or explosives in the compartment of your vehicle that contains your device or accessories.

Restricting Children's Access to Your Device

Your device is not a toy. Do not allow children to play with it as they could hurt themselves and others, damage the device, or make calls that increase your phone bill.

Caring for the Battery

Protecting Your Battery

The guidelines listed below help you get the most out of your battery's performance.

- ▶ Use only specified batteries and desktop chargers. These chargers are designed to maximize battery life. Using other batteries or chargers voids your warranty and may cause damage.
- ▶ In order to avoid damage, charge the battery only in temperatures that range from 32° F to 95° F (0° C to 35° C).
- ▶ Don't use the battery charger in direct sunlight or in high humidity areas, such as the bathroom.
- ▶ Never dispose of the battery by incineration.
- ▶ Keep the metal contacts on top of the battery clean.
- ▶ Don't attempt to disassemble or short-circuit the battery.
- ▶ The battery may need recharging if it has not been used for a long period of time.
- ▶ It's best to replace the battery when it no longer provides acceptable performance. It can be recharged hundreds of times before it needs replacing.
- ▶ Do not store the battery in temperatures that exceed the recommended range (–4° F to 140° F [–20° C to 60° C]).

Disposal of Lithium Ion (Lilon) Batteries

For safe disposal options of your LiIon batteries, contact your nearest Sprint-authorized service center.

Special Note: Be sure to dispose of your battery properly. In some areas, the disposal of batteries in household or business trash may be prohibited.

Note: For safety, do not handle a damaged or leaking Lilon battery.

Warning

- ▶ Should the device produce excessive heat, smoke, or strange odors, remove the battery (all data may be lost), unplug the AC adapter (if in use), and contact your nearest Sprint-authorized service center. Fire, electric shock, or explosion may result.
- ▶ Should the device produce excessive heat, change color or shape, or change in any way after use, charging, or storage, remove the battery (all data may be lost), remove the AC adapter (if in use), and contact your nearest Sprint-authorized service center. Fire, electric shock, or explosion may result.
- ▶ Should any foreign material (metal objects, water or any other liquid) enter the device, remove the battery (all data may be lost), remove the AC adapter (if in use), and contact your nearest Sprint-authorized service center. Fire or electric shock may result.
- ▶ Should you drop this device or break the case, remove the battery (all data may be lost), remove the AC adapter (if in use), and contact your nearest Sprint-authorized service center. Fire, electric shock, or explosion may result.
- ▶ Do not modify this device. Fire or electric shock may result.
- ▶ Do not disassemble this device. Electric shock may result.
- ▶ Do not use any voltage that differs from the power voltage recommended. In addition, do not overload outlets. Fire or electric shock may result.
- ▶ Do not remove the electrical plug with wet hands. Electric shock may result.
- ▶ Do not damage or modify the electrical cord. Do not bend, pull, or place heavy items on top of the electrical cord. Fire or electric shock may result.
- ▶ Do not use the electrical cord if the electrical plug is damaged or if it does not fit snugly into the outlet. Fire or electric shock may result from an electrical short.

- ▶ Do not touch the metal contacts of the AC adapter or connector. Electric shock may result.
- ▶ Do not pour water on or allow this device to get damp. Fire or electric shock may result.
- ▶ Do not place a container filled with water or any liquid on or near this device, as the liquid may spill and enter the device. Fire or electric shock may result.
- ▶ Do not place this device in an area of high humidity or dust. Malfunction, fire, or electric shock may result.
- ▶ Do not use the device in any area where it can get wet, such as in a bathroom or shower. Fire or electric shock may result.
- ▶ Do not place in fire or heat in any way. Fire or explosion may result.
- ▶ Do not heat this device in a microwave oven or on a hot plate. Fire or explosion may result.
- ▶ Do not use this device/phone in areas of restricted use, such as on aircraft. It could disrupt the normal operation of instruments and may cause an accident.
- ▶ Do not use this device near other devices that produce strong magnetic fields. Malfunction may result.
- ▶ Do not allow children to swallow any small parts that can be removed from this device. Store any small parts from this device out of the reach of children. Should a child swallow any of parts from this device, immediately consult a physician.
- ▶ Remove dust from the electrical plug prongs and the outlet area. Fire may result.
- ▶ Always unplug the AC adapter from the outlet if there is a thunderstorm warning or if there is a possibility of lightning striking nearby. Fire or malfunction may result.
- ▶ If charging does not complete after the specified charge time, stop charging and consult your nearest Sprint-authorized service center.

- ▶ Should you get any fluid from the battery in your eyes, DO NOT rub them. Immediately rinse with clean water and seek medical attention. Blindness may result.
- ▶ Should any fluid from the battery come in contact with skin or clothes, immediately rinse with clean water. Skin rash may result.
- ▶ Ensure that children do not place the plastic bags from the packaging over their heads or in their mouths. Suffocation may result.

Caution

- ▶ Do not drop or place foreign objects in any opening of this device. Fire, electric shock, or malfunction may result.
- ▶ Do not insert or connect wires or any other conductor to the terminals of this device. Fire, electric shock, or malfunction may result.
- ▶ Do not place heavy objects on top of this device as the glass display or cover may break. Injury and malfunction may result.
- ▶ Do not place on any unsteady, unstable, or slanted surface, as the device may drop. Injury and malfunction may result.
- ▶ Do not use or store for long periods of time near places of extreme such as inside of a car on a hot day, near fire, or next to a stove. The device casing may become excessively hot, deformed, or melt. The inside of the device may also become hot, causing fire or malfunction.
- ▶ Do not wrap or cover a device in use or the AC adapter with a cloth. The inside of the device may also become hot, causing fire or malfunction.
- ▶ Do not move the device too quickly or with exaggerated movements. The stylus may be dislodged from the device and injury or property damage may result.
- ▶ Do not place in an area of strong vibrations. Malfunction may result.
- ▶ If you feel any abnormalities on your skin, immediately stop use of this device and consult a dermatologist. Low temperature burns, itching, or rash may occur with some users.
- ▶ Avoid rapid temperature changes. Condensation may occur, resulting in malfunction.

- ▶ Do not use your fingernails to open any lids or operate any switches on this device. Injury to your fingertip may result.
- ▶ Insure that the plug is snugly inserted into the outlet. Fire or malfunction may result.
- ▶ If charging the device in a room of too hot ambient temperatures, the LED for charging will illuminate red and charging will stop. Resume charging in an ambient temperature from 32° F to 95° F (0° C to 35° C). If the red LED remains illuminated, remove the AC adapter, remove the battery (all data may be lost), and contact your nearest Sprint-authorized service center.
- ▶ Before moving this device while it is charging, always remove the AC adapter from the outlet. Damage to the cord, fire, or electric shock may result.
- ▶ Always grip the electrical cord by its plug when pulling it out of an outlet. Pulling it out of an outlet by the cord can lead the inner wire to be exposed or broken. Fire or electric shock may result.
- ▶ When not using this device for long periods of time, always remove the electrical cord from the outlet for safety. Insulation wear, fire, or electric shock may result. Also, insure that all data is previously backed-up.
- ▶ When traveling abroad, never plug the AC adapter into a power source that does not correspond to both the voltage and the frequency specified on the rating plate of the AC adapter, as device damage and fire will result. The supplied AC adapter cable is an AC 125 V type and should not be connected to a power source exceeding 125 volts. Fire may result. Connecting to a power source that exceeds 125 volts should only be done using a cable suitable for that voltage.
- ▶ Do not use AC adapters or electrical cords not specifically designed for this device. Do not modify or disassemble the AC adapter. Fire, malfunction, or bodily injury may result.
- ▶ Do not press strongly on or hit the touch screen. Electrical shock or malfunction may result.

- ▶ Do not sit on the device when it is located in your back pocket. Damage to the device, malfunction, or bodily injury may result.
- ▶ The tip of the stylus is sharp. Do not aim at people. Store it out of the reach of children. Misusing the stylus may result in injury.
- ▶ When using this device for an extended period of time, take a break every hour for 10 to 15 minutes to rest your eyes and your hands.
- ▶ Do not operate this device while handling chemicals such as benzine. Discoloration, malfunction, or deformation may result.
- ▶ Do not wipe the screen with a damp cloth. Water may enter the device and cause malfunction.

Precautions for Use

- ▶ Memory contents of this device may change or be lost due to an error in operation or malfunction. Back-up all important data on a memory card or personal computer.
- ▶ When backing-up data, always connect the AC adapter.
- ▶ Reset the device if the device response time slows or the screen freezes, which may be caused by a lack of memory. See “Resetting” on page 25. Periodic resetting is recommended for stable use.
- ▶ Do not roughly handle or drop this device.
- ▶ Do not connect any components to this device other than those specified or recommended.
- ▶ Use only the specified batteries with this device. Bodily injury, device malfunction, or fire may result from a battery rupture or leakage.

Instructions for Daily Use

- ▶ Ensure that connectors of the cables are straight when they are inserted or removed from connectors on the device. Forcing the connectors may cause them to break.
- ▶ Do not use excessive force when inserting or removing a memory card.
- ▶ Do not insert any foreign objects into the opening of the card slot.

- ▶ Do not place heavy objects on the device.
- ▶ Do not push with excessive force on or around the touch screen.
- ▶ Lightly wipe dust from the touch screen using a dry, soft cloth.
- ▶ The device and the AC adapter may become hot during use. This is normal.
- ▶ Always use the supplied AC adapter when charging the battery.
- ▶ Do not use objects other than your finger or the accompanying stylus to operate the touch screen. This may cause the touch screen surface to become scratched or ruptured and may result in bodily injury.
- ▶ Tap lightly when using the accompanying stylus.
- ▶ Using the touch screen without cleaning off dust can cause the surface to scratch.
- ▶ The softcase accompanying this device is meant for this device only. Do not place anything other than the device into the softcase.
- ▶ To prevent any possible leaks of your personal information when disposing of or surrendering this device, delete all data and return the device to its defaults. See “Initialization” on page 26 for information on Initialization.

Acknowledging Special Precautions and the FCC Notice

FCC Notice

This device may cause TV or radio interference if used in close proximity to receiving equipment. The FCC can require you to stop using the device if such interference cannot be eliminated. Vehicles using liquefied petroleum gas (propane or butane) must comply with the National Fire Protection Standard (NFPA-58). For a copy of this standard, contact the National Fire Protections Association, One Batterymarch Park, Quincy, MA 02269, Attn: Publication Sales Division.

Cautions

Any changes or modifications to your device not expressly approved by the party responsible for compliance could void your warranty for this equipment and void your authority to operate this equipment. Only use specified batteries, antennas and chargers. Although your device is quite sturdy, it is a complex piece of equipment and can be broken. Avoid dropping, hitting, bending, or sitting on it.

Use only the supplied antenna. Unauthorized antennas, modifications, or attachments could impair call quality, damage the phone, or result in violation of FCC regulations. Do not use the phone with a damaged antenna. Please contact your local dealer for replacement antenna.

Tests for SAR are conducted using standard operating positions specified by the FCC with the device transmitting at its highest certified power level in all tested frequency bands. Although the SAR is determined at the highest certified power level, the actual SAR level of the device while in operation can be well below the maximum value. This is because the device is designed to operate at multiple power levels so as to use only the power required to reach the network. In general, the closer you are to a wireless base station antenna, the lower the power output.

Specific Absorption Rates (SAR) for Wireless Phones

The SAR is a value that corresponds to the relative amount of RF energy absorbed in the head of a user of a wireless device.

The SAR value of a phone is the result of an extensive testing, measuring and calculation process. It does not represent how much RF the phone emits. All phone models are tested at their highest value in strict laboratory settings. But when in operation, the SAR of a phone can be substantially less than the level reported to the FCC. This is because of a variety of factors including its proximity to a base station antenna, phone design and other factors. What is important to remember is that each phone meets strict federal guidelines. Variations in SARs do not represent variation in safety.

All phones must meet the federal standard, which incorporates a substantial margin of safety. As stated above, variations in SAR values between different model phones do not mean variations in safety. SAR

values at or below the federal standard of 1.6 W/Kg are considered safe for use by the public.

The highest reported SAR values of the [ABLSH-G1000] are:

PCS mode (Part 24) – Head: 1.44 W/kg; Body-worn: 1.17 W/kg

FCC Radiofrequency Emission

This phone meets the FCC Radiofrequency Emission Guidelines. FCC ID number: ABLSH-G1000. More information on the phone's SAR can be found from the following FCC website: <http://www.fcc.gov/oet/fccid>.

FCC RF Exposure Information

In order to comply with FCC RF exposure guidelines for body-worn operation, use only supplied accessories. Use of any other accessories may not comply with FCC RF exposure guidelines.

Belt Worn Operation

For belt worn operation use only the supplied softcase and belt clip. Use of this device without the supplied softcase and belt clip may not comply with FCC RF exposure guidelines.

Lap Held Operation

When using the device in the lap held position, the device must remain inside the supplied softcase with the front flip-cover wrapped and stowed along the back surface as illustrated below. This also applies to when the device is in speakerphone operation and is used in the lap held position. Use of this device in any other lap held configuration may violate FCC RF exposure guidelines.

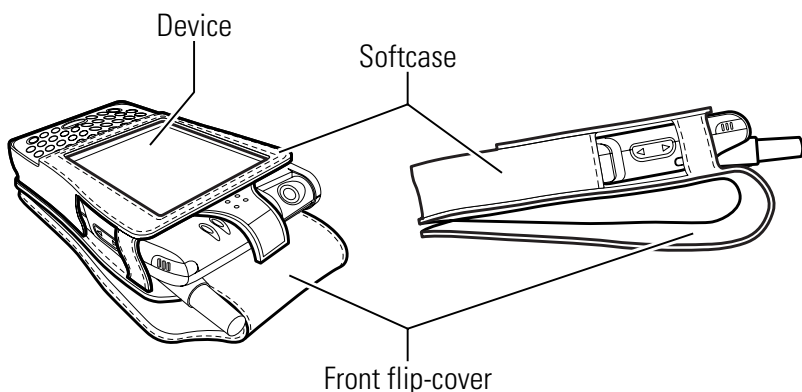

Hand Held Operation

For hand held operation the device is supplied with a thumb operated keyboard. For optimum performance both thumbs should be present on the keyboard at all times. Although the softcase is designed to allow operation in this mode, the softcase is not required in order to comply with RF Exposure guidelines in this position.

Normal Phone Operation

While the device is being used for normal phone operation, the softcase is not required in order to comply with RF Exposure guidelines.

For more information about RF exposure, visit the FCC Website at www.fcc.gov.

FCC Part 15

Warning: This device complies with part 15 of the FCC Rules. Operation is subject to the following two conditions: (1) This device may not cause harmful interference, and (2) this device must accept any interference received, including interference that may cause undesired operation.

Note: This equipment has been tested and found to comply with the limits for a Class B digital device, pursuant to part 15 of the FCC Rules. These limits are designed to provide reasonable protection against harmful interference in a residential installation. This equipment generates, uses and can radiate radio frequency energy and, if not installed and used in accordance with the instructions, may cause harmful interference to radio communications. However, there is no guarantee that interference will not occur in a particular installation. If this equipment does cause harmful interference to radio or television reception, which can be determined by turning the equipment off and on, the user is encouraged to try to correct the interference by one or more of the following measures:

- ▶ Reorient or relocate the receiving antenna.
- ▶ Increase the separation between the equipment and receiver.

- ▶ Connect the equipment into an outlet on a circuit different from that to which the receiver is connected.
- ▶ Consult the dealer or an experienced radio/TV technician for help.

Caution to the user: Changes or modifications not expressly approved by Hitachi Ltd. void the user's authority to operate the equipment.

Consumer Information on Wireless Phones

(The following information comes from a consumer information Website jointly sponsored by the U.S. Food and Drug Administration (FDA) and the Federal Communications Commission (FCC), entitled “Cell Phone Facts: Consumer Information on Wireless Phones.” The information reproduced herein is dated April 3, 2002. For further updates, please visit the Website: <http://www.fda.gov/cellphones/>.)

1. What is radiofrequency energy (RF)?

Radiofrequency (RF) energy is another name for radio waves. It is one form of electromagnetic energy that makes up the electromagnetic spectrum. Some of the other forms of energy in the electromagnetic spectrum are gamma rays, x-rays and light. Electromagnetic energy (or electromagnetic radiation) consists of waves of electric and magnetic energy moving together (radiating) through space. The area where these waves are found is called an electromagnetic field.

Radio waves are created due to the movement of electrical charges in antennas. As they are created, these waves radiate away from the antenna. All electromagnetic waves travel at the speed of light. The major differences between the different types of waves are the distances covered by one cycle of the wave and the number of waves that pass a certain point during a set time period. The wavelength is the distance covered by one cycle of a wave. The frequency is the number of waves passing a given point in one second. For any electromagnetic wave, the wavelength multiplied by the frequency equals the speed of light. The frequency of an RF signal is usually expressed in units called hertz (Hz). One Hz equals one wave per second. One kilohertz (kHz) equals one thousand waves per second, one megahertz (MHz) equals one million waves per second, and one gigahertz (GHz) equals one billion waves per second.

RF energy includes waves with frequencies ranging from about 3000 waves per second (3 kHz) to 300 billion waves per second (300 GHz). Microwaves are a subset of radio waves that have frequencies ranging from around 300 million waves per second (300 MHz) to three billion waves per second (3 GHz).

2. How is radiofrequency energy used?

Probably the most important use of RF energy is for telecommunications. Radio and TV broadcasting, wireless phones, pagers, cordless phones, police and fire department radios, point-to-point links and satellite communications all rely on RF energy.

Other uses of RF energy include microwave ovens, radar, industrial heaters and sealers, and medical treatments. RF energy, especially at microwave frequencies, can heat water. Since most food has a high water content, microwaves can cook food quickly. Radar relies on RF energy to track cars and airplanes as well as for military applications. Industrial heaters and sealers use RF energy to mold plastic materials, glue wood products, seal leather items such as shoes and pocketbooks, and process food. Medical uses of RF energy include pacemaker monitoring and programming.

3. How is radiofrequency radiation measured?

RF waves and RF fields have both electrical and magnetic components. It is often convenient to express the strength of the RF field in terms of each component. For example, the unit “volts per meter” (V/m) is used to measure the electric field strength, and the unit “amperes per meter” (A/m) is used to express the magnetic field strength. Another common way to characterize an RF field is by means of the power density. Power density is defined as power per unit area. For example, power density can be expressed in terms of milliwatts (one thousandth of a watt) per square centimeter (mW/cm^2) or microwatts (one millionth of a watt) per square centimeter ($\mu\text{W}/\text{cm}^2$).

The quantity used to measure how much RF energy is actually absorbed by the body is called the Specific Absorption Rate or SAR. The SAR is a measure of the rate of absorption of RF energy. It is usually expressed in units of watts per kilogram (W/kg) or milliwatts per gram (mW/g).

4. What biological effects can be caused by RF energy?

The biological effects of radiofrequency energy should not be confused with the effects from other types of electromagnetic energy.

Very high levels of electromagnetic energy, such as is found in X-rays and gamma rays can ionize biological tissues. Ionization is a process where

electrons are stripped away from their normal locations in atoms and molecules. It can permanently damage biological tissues including DNA, the genetic material. Ionization only occurs with very high levels of electromagnetic energy such as X-rays and gamma rays. Often the term radiation is used when discussing ionizing radiation (such as that associated with nuclear power plants).

The energy levels associated with radiofrequency energy, including both radio waves and microwaves, are not great enough to cause the ionization of atoms and molecules. Therefore, RF energy is a type of non-ionizing radiation. Other types of non-ionizing radiation include visible light, infrared radiation (heat) and other forms of electromagnetic radiation with relatively low frequencies.

Large amounts of RF energy can heat tissue. This can damage tissues and increase body temperatures. Two areas of the body, the eyes and the testes, are particularly vulnerable to RF heating because there is relatively little blood flow in them to carry away excess heat.

The amount of RF radiation routinely encountered by the general public is too low to produce significant heating or increased body temperature. Still, some people have questions about the possible health effects of low levels of RF energy. It is generally agreed that further research is needed to determine what effects actually occur and whether they are dangerous to people. In the meantime, standards-setting organizations and government agencies are continuing to monitor the latest scientific findings to determine whether changes in safety limits are needed to protect human health.

FDA, EPA and other US government agencies responsible for public health and safety have worked together and in connection with WHO to monitor developments and identify research needs related to RF biological effects.

5. What levels of RF energy are considered safe?

Various organizations and countries have developed standards for exposure to radiofrequency energy. These standards recommend safe levels of exposure for both the general public and for workers. In the United States, the FCC has used safety guidelines for RF environmental exposure since 1985.

The FCC guidelines for human exposure to RF electromagnetic fields are derived from the recommendations of two expert organizations, the National Council on Radiation Protection and Measurements (NCRP) and the Institute of Electrical and Electronics Engineers (IEEE). In both cases, the recommendations were developed by scientific and engineering experts drawn from industry, government, and academia after extensive reviews of the scientific literature related to the biological effects of RF energy.

Many countries in Europe and elsewhere use exposure guidelines developed by the International Commission on Non-Ionizing Radiation Protection (ICNIRP). The ICNIRP safety limits are generally similar to those of the NCRP and IEEE, with a few exceptions. For example, ICNIRP recommends different exposure levels in the lower and upper frequency ranges and for localized exposure from certain products such as hand-held wireless telephones. Currently, the World Health Organization is working to provide a framework for international harmonization of RF safety standards.

The NCRP, IEEE, and ICNIRP all have identified a whole-body Specific Absorption Rate (SAR) value of 4 watts per kilogram (4 W/kg) as a threshold level of exposure at which harmful biological effects may occur. Exposure guidelines in terms of field strength, power density and localized SAR were then derived from this threshold value. In addition, the NCRP, IEEE, and ICNIRP guidelines vary depending on the frequency of the RF exposure. This is due to the finding that whole-body human absorption of RF energy varies with the frequency of the RF signal. The most restrictive limits on whole-body exposure are in the frequency range of 30-300 MHz where the human body absorbs RF energy most efficiently. For products that only expose part of the body, such as wireless phones, exposure limits in terms of SAR only are specified.

The exposure limits used by the FCC are expressed in terms of SAR, electric and magnetic field strength, and power density for transmitters operating at frequencies from 300 kHz to 100 GHz. The specific values can be found in two FCC bulletins, OET Bulletins 56 and 65:

<http://www.fcc.gov/oet/info/documents/bulletins/#56>;

<http://www.fcc.gov/oet/info/documents/bulletins/#65>

6. Why has the FCC adopted guidelines for RF exposure?

The FCC authorizes and licenses products, transmitters, and facilities that generate RF and microwave radiation. It has jurisdiction over all transmitting services in the U.S. except those specifically operated by the Federal Government. While the FCC does not have the expertise to determine radiation exposure guidelines on its own, it does have the expertise and authority to recognize and adopt technically sound standards promulgated by other expert agencies and organizations, and has done so. (Our joint efforts with the FDA in developing this website is illustrative of the kind of inter-agency efforts and consultation we engage in regarding this health and safety issue.)

Under the National Environmental Policy Act of 1969 (NEPA), the FCC has certain responsibilities to consider whether its actions will significantly affect the quality of the human environment. Therefore, FCC approval and licensing of transmitters and facilities must be evaluated for significant impact on the environment. Human exposure to RF radiation emitted by FCC-regulated transmitters is one of several factors that must be considered in such environmental evaluations. In 1996, the FCC revised its guidelines for RF exposure as a result of a multi-year proceeding and as required by the Telecommunications Act of 1996.

Radio and television broadcast stations, satellite-earth stations, experimental radio stations and certain wireless communication facilities are required to undergo routine evaluation for RF compliance when they submit an application to the FCC for construction or modification of a transmitting facility or renewal of a license. Failure to comply with the FCC's RF exposure guidelines could lead to the preparation of a formal Environmental Assessment, possible Environmental Impact Statement and eventual rejection of an application. Technical guidelines for evaluating compliance with the FCC RF safety requirements can be found in the FCC's OET Bulletin 65. <http://www.fcc.gov/oet/info/documents/bulletins/#65>

Low-powered, intermittent, or inaccessible RF transmitters and facilities are normally excluded from the requirement for routine evaluation for RF exposure. These exclusions are based on standard calculations and measurement data indicating that a transmitting station or equipment operating under the conditions prescribed is unlikely to cause exposures

in excess of the guidelines under normal conditions of use. Such exclusions are not exclusions from compliance, but, rather, exclusions from routine evaluation. The FCC's policies on RF exposure and categorical exclusion can be found in Section 1.1307(b) of the FCC's Rules and Regulations [(47 CFR 1.1307(b))].

7. How can I obtain the Specific Absorption Rate (SAR) value for my wireless phone?

The FCC requires that wireless phones sold in the United States demonstrate compliance with human exposure limits adopted by the FCC in 1996. The relative amount of RF energy absorbed in the head of a wireless telephone-user is given by the Specific Absorption Rate (SAR), as explained above. The FCC requires wireless phones to comply with a safety limit of 1.6 watts per kilogram (1.6 W/kg) in terms of SAR.

Information on SAR for a specific phone model can be obtained for many recently manufactured phones using the FCC identification (ID) number for that model. The FCC ID number is usually printed somewhere on the case of the phone. Sometimes it may be necessary to remove the battery pack to find the number. Once you have the ID number, go to the following Web address: www.fcc.gov/oet/fccid. On this page, you will see instructions for entering the FCC ID number. Type the FCC ID number exactly as requested (the Grantee Code is the first three characters, the Equipment Product Code is the rest of the FCC ID number). Then click on "Start Search." The "Grant of Equipment Authorization" for your telephone should appear. Read through the grant for the section on "SAR Compliance," "Certification of Compliance with FCC Rules for RF Exposure" or similar language. This section should contain the value(s) for typical or maximum SAR for your phone.

Phones and other products authorized since June 2, 2000, should have the maximum SAR levels noted directly on the "Grant of Equipment Authorization." For phones and products authorized between about mid-1998 and June 2000, detailed information on SAR levels is typically found in the exhibits associated with the grant. Once a grant is accessed, the exhibits can be viewed by clicking on "View Exhibit." Grants authorized prior to 1998 are not part of the electronic database but, rather, have been documented in the form of paper records.

The FCC database does not list phones by model number. However, consumers may find SAR information from other sources as well. Some wireless phone manufacturers make SAR information available on their own Websites. In addition, some non-government Websites provide SARs for specific models of wireless phones. However, the FCC has not reviewed these sites and makes no guarantees of their accuracy. Finally, phones certified by the Cellular Telecommunications and Internet Association (CTIA) are required to provide SAR information to consumers in the instructional materials that come with the phones.

8. Do hands-free kits for wireless phones reduce risks from exposure to RF emissions?

Since there are no known risks from exposure to RF emissions from wireless phones, there is no reason to believe that hands-free kits reduce risks. Hands-free kits can be used with wireless phones for convenience and comfort. These systems reduce the absorption of RF energy in the head because the phone, which is the source of the RF emissions, will not be placed against the head. On the other hand, if the phone is mounted against the waist or other part of the body during use, then that part of the body will absorb more RF energy. Wireless phones marketed in the U.S. are required to meet safety requirements regardless of whether they are used against the head or against the body. Either configuration should result in compliance with the safety limit.

9. Do wireless phone accessories that claim to shield the head from RF radiation work?

Since there are no known risks from exposure to RF emissions from wireless phones, there is no reason to believe that accessories that claim to shield the head from those emissions reduce risks. Some products that claim to shield the user from RF absorption use special phone cases, while others involve nothing more than a metallic accessory attached to the phone. Studies have shown that these products generally do not work as advertised. Unlike “hand-free” kits, these so-called “shields” may interfere with proper operation of the phone. The phone may be forced to boost its power to compensate, leading to an increase in RF absorption. In February 2002, the Federal Trade Commission (FTC) charged two companies that sold devices that claimed to protect wireless phone

users from radiation with making false and unsubstantiated claims. According to FTC, these defendants lacked a reasonable basis to substantiate their claim.

10. What are wireless telephone base stations?

Fixed antennas used for wireless telecommunications are referred to as cellular base stations, cell stations, PCS (“Personal Communications Service”) stations or telephone transmission towers. These base stations consist of antennas and electronic equipment. Because the antennas need to be high in the air, they are often located on towers, poles, water tanks, or rooftops. Typical heights for freestanding base station towers are 50-200 feet.

Some base stations use antennas that look like poles, 10 to 15 feet in length, that are referred to as “omni-directional” antennas. These types of antennas are usually found in rural areas. In urban and suburban areas, wireless providers now more commonly use panel or sector antennas for their base stations. These antennas consist of rectangular panels, about 1 by 4 feet in dimension. The antennas are usually arranged in three groups of three antennas each. One antenna in each group is used to transmit signals to wireless phones, and the other two antennas in each group are used to receive signals from wireless phones.

At any base station site, the amount of RF energy produced depends on the number of radio channels (transmitters) per antenna and the power of each transmitter. Typically, 21 channels per antenna sector are available. For a typical cell site using sector antennas, each of the three transmitting antennas could be connected to up to 21 transmitters for a total of 63 transmitters. However, it is unlikely that all of the transmitters would be transmitting at the same time. When omni-directional antennas are used, a cellular base station could theoretically use up to 96 transmitters, but this would be very unusual, and, once again, it is unlikely that all transmitters would be in operation simultaneously. Base stations used for PCS communications generally require fewer transmitters than those used for cellular radio transmissions, since PCS carriers usually have a higher density of base station antenna sites.

11. Are wireless telephone base stations safe?

The electromagnetic RF signals transmitted from base station antennas stations travel toward the horizon in relatively narrow paths. For example, the radiation pattern for an antenna array mounted on a tower can be likened to a thin pancake centered around the antenna system. The individual pattern for a single array of sector antennas is wedge-shaped, like a piece of pie. As with all forms of electromagnetic energy, the power decreases rapidly as one moves away from the antenna. Therefore, RF exposure on the ground is much less than exposure very close to the antenna and in the path of the transmitted radio signal. In fact, ground-level exposure from such antennas is typically thousands of times less than the exposure levels recommended as safe by expert organizations. So exposure to nearby residents would be well within safety margins.

Cellular and PCS base stations in the United States are required to comply with limits for exposure recommended by expert organizations and endorsed by government agencies responsible for health and safety. Measurements made near cellular and PCS base station antennas mounted on towers have confirmed that ground-level exposures are typically thousands of times less than the exposure limits adopted by the FCC. In fact, in order to be exposed to levels at or near the FCC limits for cellular or PCS frequencies an individual would essentially have to remain in the main transmitted radio signal (at the height of the antenna) and within a few feet from the antenna. This is, of course, very unlikely to occur.

When cellular and PCS antennas are mounted on rooftops, RF levels on that roof or on others near by would probably be greater than those typically encountered on the ground. However, exposure levels approaching or exceeding safety guidelines should be encountered only very close to or directly in front of the antennas. In addition, for sector-type antennas, typically used for such rooftop base stations, RF levels to the side and in back of these antennas are insignificant. General guidelines on antenna installations and circumstances that might give rise to a concern about an facility's conformance with FCC regulations can be found in A Local Government Official's Guide to Transmitting

Antenna RF Emission Safety: Rules, Procedures, and Practical Guidance. This Guide can be accessed at: <http://www.fcc.gov/oet/rfsafety>.

12. Who regulates exposure to radiation from microwave ovens, television sets and computer monitors?

The Food and Drug Administration is responsible for protecting the public from harmful radiation emissions from these consumer products.

13. Does the FCC routinely monitor radiofrequency radiation from antennas?

The FCC does not have the resources or the personnel to routinely monitor the emissions for all the thousands of transmitters that are subject to FCC jurisdiction. However, the FCC does have measurement instrumentation for evaluating RF levels in areas that may be accessible to the public or to workers. If there is evidence for potential non-compliance with FCC exposure guidelines for a FCC-regulated facility, staff from the FCC's Office of Engineering and Technology or the FCC Enforcement Bureau can conduct an investigation, and, if appropriate, perform actual measurements. Circumstances that could give rise to a concern about an facility's conformance with FCC regulations can be found in A Local Government Official's Guide to Transmitting Antenna RF Emission Safety: Rules, Procedures, and Practical Guidance. This Guide can be accessed at: <http://www.fcc.gov/oet/rfsafety>. Potential exposure problems should be brought to the FCC's attention by contacting the FCC RF Safety Program at: 202-418-2464 or by email: rfsafety@fcc.gov.

14. Does the FCC maintain a database that includes information on the location and technical parameters of all the transmitting towers it regulates?

Each of the FCC Bureaus maintains its own licensing database system for the service(s) it regulates (e.g., television, cellular service, satellite earth stations.) The FCC issues two types of licenses: site specific and market based. In the case of site specific licensed facilities, technical operating information is collected from the licensee as part of the licensing process. However, in the case of market based licensing (e.g., PCS, cellular), the licensee is granted the authority to operate a radio communications system in a geographic area using as many facilities as are required, and

the licensee is not required to provide the FCC with specific location and operating parameters of these facilities.

Information on site specific licensed facilities can be found the “General Menu Reports” (GenMen) at

<http://gullfoss2.fcc.gov/cgi-bin/ws.exe/genmen/index.htm>.

The various FCC Bureaus also publish on at least a weekly basis, bulk extracts of their licensing databases. Each licensing database has its own unique file structure. These extracts consist of multiple, very large files. The FCC’s Office of Engineering and Technology (OET) maintains an index to these databases at

<http://www.fcc.gov/oet/info/database/fadb.html>. Entry points into the various databases include frequency, state/county, latitude/longitude, call-sign and licensee name. For further information on the Commission’s existing databases, you can contact Donald Campbell at dcampbel@fcc.gov or 202-418-2405.

15. Can local and state governmental bodies establish limits for RF exposure?

Although some local and state governments have enacted rules and regulations about human exposure to RF energy in the past, the Telecommunications Act of 1996 requires the Federal Government to control human exposure to RF emissions. In particular, Section 704 of the Act states that, “No State or local government or instrumentality thereof may regulate the placement, construction, and modification of personal wireless service facilities on the basis of the environmental effects of radio frequency emissions to the extent that such facilities comply with the Commission’s regulations concerning such emissions.” Further information on federal authority and FCC policy is available in a fact sheet from the FCC’s Wireless Telecommunications Bureau at www.fcc.gov/wtb.

16. Do wireless phones pose a health hazard?

The available scientific evidence does not show that any health problems are associated with using wireless phones. There is no proof, however, that wireless phones are absolutely safe. Wireless phones emit low levels of radiofrequency energy (RF) in the microwave range while being used. They also emit very low levels of RF when in the stand-by mode. Whereas

high levels of RF can produce health effects (by heating tissue), exposure to low level RF that does not produce heating effects causes no known adverse health effects. Many studies of low level RF exposures have not found any biological effects. Some studies have suggested that some biological effects may occur, but such findings have not been confirmed by additional research. In some cases, other researchers have had difficulty in reproducing those studies, or in determining the reasons for inconsistent results.

17. What is FDA's role concerning the safety of wireless phones?

Under the law, FDA does not review the safety of radiation-emitting consumer products such as wireless phones before they can be sold, as it does with new drugs or medical devices. However, the agency has authority to take action if wireless phones are shown to emit radiofrequency energy (RF) at a level that is hazardous to the user. In such a case, FDA could require the manufacturers of wireless phones to notify users of the health hazard and to repair, replace or recall the phones so that the hazard no longer exists.

Although the existing scientific data do not justify FDA regulatory actions, FDA has urged the wireless phone industry to take a number of steps, including the following:

- ▶ Support needed research into possible biological effects of RF of the type emitted by wireless phones;
- ▶ Design wireless phones in a way that minimizes any RF exposure to the user that is not necessary for device function; and
- ▶ Cooperate in providing users of wireless phones with the best possible information on possible effects of wireless phone use on human health

FDA belongs to an interagency working group of the federal agencies that have responsibility for different aspects of RF safety to ensure coordinated efforts at the federal level. The following agencies belong to this working group:

- ▶ National Institute for Occupational Safety and Health
- ▶ Environmental Protection Agency
- ▶ Federal Communications Commission

- ▶ Occupational Safety and Health Administration
- ▶ National Telecommunications and Information Administration

The National Institutes of Health participates in some interagency working group activities, as well.

FDA shares regulatory responsibilities for wireless phones with the Federal Communications Commission (FCC). All phones that are sold in the United States must comply with FCC safety guidelines that limit RF exposure. FCC relies on FDA and other health agencies for safety questions about wireless phones.

FCC also regulates the base stations that the wireless phone networks rely upon. While these base stations operate at higher power than do the wireless phones themselves, the RF exposures that people get from these base stations are typically thousands of times lower than those they can get from wireless phones. Base stations are thus not the primary subject of the safety questions discussed in this document.

18. What kinds of phones are the subject of this update?

The term “wireless phone” refers here to hand-held wireless phones with built-in antennas, often called “cell,” “mobile,” or “PCS” phones. These types of wireless phones can expose the user to measurable radiofrequency energy (RF) because of the short distance between the phone and the user’s head. These RF exposures are limited by Federal Communications Commission safety guidelines that were developed with the advice of FDA and other federal health and safety agencies. When the phone is located at greater distances from the user, the exposure to RF is drastically lower because a person’s RF exposure decreases rapidly with increasing distance from the source. The so-called “cordless phones,” which have a base unit connected to the telephone wiring in a house, typically operate at far lower power levels, and thus produce RF exposures well within the FCC’s compliance limits.

19. What are the results of the research done already?

The research done thus far has produced conflicting results, and many studies have suffered from flaws in their research methods. Animal experiments investigating the effects of radiofrequency energy (RF) exposures characteristic of wireless phones have yielded conflicting

results that often cannot be repeated in other laboratories. A few animal studies, however, have suggested that low levels of RF could accelerate the development of cancer in laboratory animals. However, many of the studies that showed increased tumor development used animals that had been genetically engineered or treated with cancer-causing chemicals so as to be pre-disposed to develop cancer in the absence of RF exposure. Other studies exposed the animals to RF for up to 22 hours per day. These conditions are not similar to the conditions under which people use wireless phones, so we don't know with certainty what the results of such studies mean for human health.

Three large epidemiology studies have been published since December 2000. Between them, the studies investigated any possible association between the use of wireless phones and primary brain cancer, glioma, meningioma, or acoustic neuroma, tumors of the brain or salivary gland, leukemia, or other cancers. None of the studies demonstrated the existence of any harmful health effects from wireless phone RF exposures. However, none of the studies can answer questions about long-term exposures, since the average period of phone use in these studies was around three years.

20. What research is needed to decide whether RF exposure from wireless phones poses a health risk?

A combination of laboratory studies and epidemiological studies of people actually using wireless phones would provide some of the data that are needed. Lifetime animal exposure studies could be completed in a few years. However, very large numbers of animals would be needed to provide reliable proof of a cancer promoting effect if one exists. Epidemiological studies can provide data that is directly applicable to human populations, but 10 or more years' follow-up may be needed to provide answers about some health effects, such as cancer. This is because the interval between the time of exposure to a cancer-causing agent and the time tumors develop - if they do - may be many, many years. The interpretation of epidemiological studies is hampered by difficulties in measuring actual RF exposure during day-to-day use of wireless phones. Many factors affect this measurement, such as the angle at which the phone is held, or which model of phone is used.

21. What is FDA doing to find out more about the possible health effects of wireless phone RF?

FDA is working with the U.S. National Toxicology Program and with groups of investigators around the world to ensure that high priority animal studies are conducted to address important questions about the effects of exposure to radiofrequency energy (RF).

FDA has been a leading participant in the World Health Organization International Electromagnetic Fields (EMF) Project since its inception in 1996. An influential result of this work has been the development of a detailed agenda of research needs that has driven the establishment of new research programs around the world. The Project has also helped develop a series of public information documents on EMF issues.

FDA and the Cellular Telecommunications & Internet Association (CTIA) have a formal Cooperative Research and Development Agreement (CRADA) to do research on wireless phone safety. FDA provides the scientific oversight, obtaining input from experts in government, industry, and academic organizations. CTIA-funded research is conducted through contracts to independent investigators. The initial research will include both laboratory studies and studies of wireless phone users. The CRADA will also include a broad assessment of additional research needs in the context of the latest research developments around the world.

22. What steps can I take to reduce my exposure to radiofrequency energy from my wireless phone?

If there is a risk from these products—and at this point we do not know that there is—it is probably very small. But if you are concerned about avoiding even potential risks, you can take a few simple steps to minimize your exposure to radiofrequency energy (RF). Since time is a key factor in how much exposure a person receives, reducing the amount of time spent using a wireless phone will reduce RF exposure.

If you must conduct extended conversations by wireless phone every day, you could place more distance between your body and the source of the RF, since the exposure level drops off dramatically with distance. For example, you could use a headset and carry the wireless phone away from your body or use a wireless phone connected to a remote antenna.

Again, the scientific data do not demonstrate that wireless phones are harmful. But if you are concerned about the RF exposure from these products, you can use measures like those described above to reduce your RF exposure from wireless phone use.

23. What about children using wireless phones?

The scientific evidence does not show a danger to users of wireless phones, including children and teenagers. If you want to take steps to lower exposure to radiofrequency energy (RF), the measures described above would apply to children and teenagers using wireless phones. Reducing the time of wireless phone use and increasing the distance between the user and the RF source will reduce RF exposure.

Some groups sponsored by other national governments have advised that children be discouraged from using wireless phones at all. For example, the government in the United Kingdom distributed leaflets containing such a recommendation in December 2000. They noted that no evidence exists that using a wireless phone causes brain tumors or other ill effects. Their recommendation to limit wireless phone use by children was strictly precautionary; it was not based on scientific evidence that any health hazard exists.

24. What about wireless phone interference with medical equipment?

Radiofrequency energy (RF) from wireless phones can interact with some electronic devices. For this reason, FDA helped develop a detailed test method to measure electromagnetic interference (EMI) of implanted cardiac pacemakers and defibrillators from wireless telephones. This test method is now part of a standard sponsored by the Association for the Advancement of Medical Instrumentation (AAMI). The final draft, a joint effort by FDA, medical device manufacturers, and many other groups, was completed in late 2000. This standard will allow manufacturers to ensure that cardiac pacemakers and defibrillators are safe from wireless phone EMI.

FDA has tested hearing aids for interference from handheld wireless phones and helped develop a voluntary standard sponsored by the Institute of Electrical and Electronic Engineers (IEEE). This standard specifies test methods and performance requirements for hearing aids

and wireless phones so that no interference occurs when a person uses a “compatible” phone and a “compatible” hearing aid at the same time. This standard was approved by the IEEE in 2000.

FDA continues to monitor the use of wireless phones for possible interactions with other medical devices. Should harmful interference be found to occur, FDA will conduct testing to assess the interference and work to resolve the problem.

25. Which other federal agencies have responsibilities related to potential RF health effects?

Certain agencies in the Federal Government have been involved in monitoring, researching or regulating issues related to human exposure to RF radiation. These agencies include the Food and Drug Administration (FDA), the Environmental Protection Agency (EPA), the Occupational Safety and Health Administration (OSHA), the National Institute for Occupational Safety and Health (NIOSH), the National Telecommunications and Information Administration (NTIA) and the Department of Defense (DOD).

By authority of the Radiation Control for Health and Safety Act of 1968, the Center for Devices and Radiological Health (CDRH) of the FDA develops performance standards for the emission of radiation from electronic products including X-ray equipment, other medical devices, television sets, microwave ovens, laser products and sunlamps. The CDRH established a product performance standard for microwave ovens in 1971 limiting the amount of RF leakage from ovens. However, the CDRH has not adopted performance standards for other RF-emitting products. The FDA is, however, the lead federal health agency in monitoring the latest research developments and advising other agencies with respect to the safety of RF-emitting products used by the public, such as cellular and PCS phones.

The FDA’s microwave oven standard is an emission standard (as opposed to an exposure standard) that allows specific levels of microwave leakage (measured at five centimeters from the oven surface). The standard also requires ovens to have two independent interlock systems that prevent the oven from generating microwaves the moment that the latch is released or the door of the oven is opened. The FDA has stated that ovens that meet

its standards and are used according to the manufacturer's recommendations are safe for consumer and industrial use. More information is available from: www.fda.gov/cdrh.

The EPA has, in the past, considered developing federal guidelines for public exposure to RF radiation. However, EPA activities related to RF safety and health are presently limited to advisory functions. For example, the EPA now chairs an Inter-agency Radiofrequency Working Group, which coordinates RF health-related activities among the various federal agencies with health or regulatory responsibilities in this area.

OSHA is responsible for protecting workers from exposure to hazardous chemical and physical agents. In 1971, OSHA issued a protection guide for exposure of workers to RF radiation [29 CFR 1910.97]. However, this guide was later ruled to be only advisory and not mandatory. Moreover, it was based on an earlier RF exposure standard that has now been revised. At the present time, OSHA uses the IEEE and/or FCC exposure guidelines for enforcement purposes under OSHA's "general duty clause" (for more information see:

<http://www.osha-slc.gov/SLTC/radiofrequencyradiation/index.html>).

NIOSH is part of the U.S. Department of Health and Human Services. It conducts research and investigations into issues related to occupational exposure to chemical and physical agents. NIOSH has, in the past, undertaken to develop RF exposure guidelines for workers, but final guidelines were never adopted by the agency. NIOSH conducts safety-related RF studies through its Physical Agents Effects Branch in Cincinnati, Ohio.

The NTIA is an agency of the U.S. Department of Commerce and is responsible for authorizing Federal Government use of the RF electromagnetic spectrum. Like the FCC, the NTIA also has NEPA responsibilities and has considered adopting guidelines for evaluating RF exposure from U.S. Government transmitters such as radar and military facilities.

The Department of Defense (DOD) has conducted research on the biological effects of RF energy for a number of years. This research is now conducted primarily at the U.S. Air Force Research Laboratory located at Brooks Air Force Base, Texas. The DOD Website for RF biological effects

information is listed with other sites in conjunction with a question on other sources of information, below.

26. Who funds and carries out research on the biological effects of RF energy?

Research into possible biological effects of RF energy is carried out in laboratories in the United States and around the world. In the U.S., most research has been funded by the Department of Defense, due to the extensive military use of RF equipment such as radar and high-powered radio transmitters. In addition, some federal agencies responsible for health and safety, such as the Environmental Protection Agency (EPA) and the U.S. Food and Drug Administration (FDA), have sponsored and conducted research in this area. At the present time, most of the non-military research on biological effects of RF energy in the U.S. is being funded by industry organizations. More research is being carried out overseas, particularly in Europe.

In 1996, the World Health Organization (WHO) established the International EMF Project to review the scientific literature and work towards resolution of health concerns over the use of RF technology. WHO maintains a Website that provides extensive information on this project and about RF biological effects and research (www.who.ch/peh-emf).

FDA, EPA and other US government agencies responsible for public health and safety have worked together and in connection with WHO to monitor developments and identify research needs related to RF biological effects.

Hardware Specifications

Processor		Intel® PXA255 Processor with Intel® XScale™ Technology, 400MHz
Memory	RAM	32MB SDRAM*1
	ROM	32MB Flash EEPROM
Antenna		1.9GHz (PCS), 1.5GHz (GPS)
Screen	Display*2	3.5-inch semi-transparent color TFT LCD
	Resolution	240 × 320 dots
	Display	65,536 colors
	Illumination	Backlight method
Input		Keyboard, Touch panel, Jog-wheel
Interface	Audio	Microphone, Speaker, Receiver, Headset jack (ø2.5 mm)*3
	Notification	LED × 3 (Charging, Reminder, Phone power), Vibrating device
	Camera	Rotary VGA camera
	IrDA port	IrDA Version 1.3 compatible (115 kbps)
	SD card slot	SD card*4 / MultiMediaCard*5 available
	USB function port	USB Mini-B type
	Cradle connector	
	AC adapter jack	

1. The total capacity of memory for data storage and program execution is 32 MB.
2. Even though the display is produced with very high technologies, some pixels may always appear blight and some pixels may always appear dark. This does not designate malfunction.
3. When using 3.5 mm (1/8 inch) stereo headphones, use the supplied stereo mini plug adapter.
4. SD card standard conformed. The SD card security function is not available. Such data cannot be used that has been decoded using a device which supports the SD card security function.
5. This device supports a Secure MultiMediaCard.

Power	Main battery	Detachable Lithium Ion battery Voltage: 3.7 V DC, capacity: 1500 mAh	
		Operating time* ⁶ (25°C / 77°F)	Talk time: Approx. 2.5 hours* ⁷ Standby time: Approx. 7 days* ⁷ PDA operation time: Approx. 12 hours* ⁸
		Charging time	Approx. 3 hours
		Data holding period	Approx. 5 days* ⁹
	Backup battery	Built-in battery (For backing up data when the main battery is replaced* ¹⁰)	
	AC adapter* ¹¹	Input: 100-240 V AC, 50-60 Hz Output: 5.0 V DC, 2.0 A	
External dimensions	Main body	83 (W) × 146.5 (H) × 22.5 (D) mm* ¹²	
	USB Cradle	88 (W) × 76 (H) × 90 (D) mm	
Weight	Main body	238 g	
	USB Cradle	227 g	
Operating temperature		0°C to 40°C (32°F to 104°F) (for charging, 0°C to 35°C (32°F to 95°F))	
Operating humidity		30% to 80% (There should be no condensation.)	

6. The operating time is provided just as a reference; and this time varies depending on storage status and operating temperatures.
7. With the LCD backlight switched off. This time varies depending on radio wave conditions and function settings.
8. When 30% continuous operation and 70% display are repeated in phone call waiting status with the LCD backlight switched off.
9. When the device is left at an ambient temperature of 25°C (77°F) after switching the device on has been disabled.
10. Confirm that the backup battery power warning has not been displayed on the Power screen under Settings.
11. The supplied AC adapter cable is designed for 125 V AC. When the power source supplies more than 125 V AC, use a different cable that is appropriate for the voltage.
12. Projections excluded.

Owner's Record

The model number, regulatory number and serial number are located on a nameplate inside the battery compartment. Record the serial number in the space provided below. This will be helpful if you need to contact us about your phone in the future.

Model: SH-G1000

Serial No.:

User Guide Proprietary Notice

CDMA Technology is licensed by QUALCOMM Incorporated under one or more of the following patents:

4,901,307	5,056,109	5,101,501	5,109,390	5,228,054
5,267,261	5,267,262	5,337,338	5,414,796	5,416,797
5,490,165	5,504,773	5,506,865	5,511,073	5,535,239
5,544,196	5,568,483	5,600,754	5,657,420	5,659,569
5,710,784	5,778,338			

T9 Text Input is licensed by Tegic Communications and is covered by U.S. Pat. 5,818,437, U.S. Pat. 5,953,541, U.S. Pat. 6,011,554 and other patents pending.

Section 4B

Customer Limited Warranty

In This Section

▶ **Customer Limited Warranty**

This section contains the Customer Limited Warranty for your PCS Phone.

For information about the Terms and Conditions of your PCS Service, please see the Start Here guide included with your device. For the most recent version of the Terms and Conditions, please visit www.sprintpcs.com.

Customer Limited Warranty

SPRINT SPECTRUM, L.P., (Sprint) offers you a limited warranty that the enclosed subscriber unit (Product), including accessories in the product package, will be free from defects in material or workmanship as follows:

SUBSCRIBER UNIT:

A. SPRINT ONE (1) YEAR LIMITED WARRANTY: For a period of one (1) year from the date of purchase, Sprint will, at its option, either pay the parts and labor charges to any authorized PCS Phone service facility to repair or replace a defective product (with new or rebuilt parts/replacements). After this one (1) year period, you must pay all parts, shipping and labor charges.

B. REPAIRS: For a period equal to the remainder of the original limited warranty period on an original Product or for the 180 days after the date of repair/replacement, whichever is longer, Sprint will repair or replace (with new or rebuilt replacement) defective parts or Product used in the repair or replacement of the original Product under this Limited Warranty.

Proof of purchase in the form of a bill of sales or receipted invoice warranty repair document which is evidence that the Product is within the warranty period must be presented to obtain warranty service. This limited warranty is not transferable to any third party, including but not limited to any subsequent purchaser or owner of the Products.

Transfer or resale of a Product will automatically terminate warranty coverage with respect to the Products.

This limited warranty does not cover and is void with respect to the following: (i) Products which have been improperly installed, repaired, maintained or modified (including the antenna); (ii) Products which have been subjected to misuse (including Products used in conjunction with hardware electrically or mechanically incompatible or used with accessories not supplied by Sprint), abuse accident, physical damage, abnormal operation, improper handling and storage, neglect, exposure to fire, water or excessive moisture or dampness or extreme changes in climate or temperature, (iii) Products operated outside published maximum ratings; (iv) cosmetic damage (including the LCD touch

screen); (v) Products on which warranty stickers or Product serial numbers have been removed, altered, or rendered illegible; (vi) customer instruction; (vii) cost of installation, removal or reinstallation; (viii) signal reception problems (unless caused by defect in material and workmanship); (ix) damage the result of fire, flood, acts of God or other acts which are not the fault of Sprint and which the Product is not specified to tolerate, including damage caused by mishandling and blown fuses; (x) consumables (such as fuses); or (xi) any Products which have been opened, repaired, modified or altered by anyone other than Sprint or a Sprint authorized service center.

This warranty does not cover customer education, instruction, installation, set up adjustments, or signal reception problems.

This warranty is valid only in the United States.

USE WITH ACCESSORIES NOT SUPPLIED BY SPRINT OR OTHERWISE NOT EXPRESSLY AUTHORIZED BY SPRINT MAY BE DANGEROUS.

SPRINT SPECIFICALLY DISCLAIMS LIABILITY, AND SHALL HAVE NO OBLIGATION TO PROVIDE TO BUYER ANY OTHER REMEDY, FOR ANY AND ALL DIRECT, INDIRECT, SPECIAL, GENERAL, INCIDENTAL OR CONSEQUENTIAL DAMAGES, INCLUDING, BUT NOT LIMITED TO LOSS OF PROFITS, LOST SALES, LOSS OF USE OF THE PRODUCT, OR ANTICIPATED PROFITS ARISING OUT OF USE OF OR INABILITY TO USE ANY PRODUCT (FOR EXAMPLE, WASTED AIRTIME CHARGES DUE TO THE MALFUNCTION OF A PRODUCT), DAMAGE DUE TO IMPROPER OPERATION OR MAINTENANCE, INSTALLATION, CONNECTION TO IMPROPER VOLTAGE SUPPLY, OR ATTEMPTED REPAIR OF THE PRODUCT BY ANYONE OTHER THAN A FACILITY AUTHORIZED BY SPRINT. THIS WARRANTY DOES NOT COVER PRODUCTS SOLD AS IS OR WITH ALL FAULTS, OR CONSUMABLES, (SUCH AS FUSES). THIS WARRANTY DOES NOT APPLY WHEN THE MALFUNCTION RESULTS FROM USE OF THE PRODUCT IN CONJUNCTION WITH ACCESSORIES, PRODUCTS OR ANCILLARY OR PERIPHERAL EQUIPMENT NOT SUPPLIED BY OR EXPRESSLY AUTHORIZED FOR USE BY SPRINT, AND WHERE IT IS DETERMINED BY SPRINT THAT THERE IS NO FAULT WITH THE PRODUCT ITSELF.

REPAIR OR REPLACEMENT, AS PROVIDED UNDER THE WARRANTY, IS YOUR SOLE AND EXCLUSIVE REMEDY FOR BREACH OF THE LIMITED

WARRANTY. TO THE EXTENT PERMITTED BY APPLICABLE LAW, SPRINT MAKES NO OTHER WARRANTIES OF ANY KIND, EXPRESS OR IMPLIED, WITH RESPECT TO THE PRODUCTS FOR A PARTICULAR PURPOSE OR AGAINST INFRINGEMENT WITHIN THE TIME PERIOD SPECIFIED IN THE LIMITED WARRANTY OF MERCHANTABILITY OR FITNESS FOR A PARTICULAR PURPOSE ON THIS PRODUCT IS LIMITED IN DURATION TO THE DURATION OF THIS WARRANTY.

Some States do not allow the exclusion or limitation of incidental or consequential damages, or allow limitations on how long an implied warranty last, so the above limitations or exclusions may not apply to you.

This limited warranty gives you specific legal rights, and you may have other rights which vary from the State to State.

For other Warranty Service Information, please call PCS CUSTOMER SOLUTIONS at 1-888-211-4727.

Copyright © 2003 Sprint Spectrum L.P. All rights reserved. No reproduction in whole or in part allowed without prior written approval. Sprint, PCS Business Connection, and the diamond logo are trademarks of Sprint Communications Company L.P.

Microsoft, ActiveSync, Outlook, Pocket Outlook, Windows, Windows NT, and the Windows logo are either registered trademarks or trademarks of Microsoft Corporation in the United States and /or other countries. Microsoft products are licensed to OEMs by Microsoft Licensing, Inc., a wholly owned subsidiary of Microsoft Corporation.

All other trademarks are property of their respective owners.

Please note that copying and modifying, changing or editing any material on the Internet, except using it privately for non-commercial purpose, may infringe the author's copyright protected by the Copyright Act.

Index

Numerics

4/5 Digit Dial 76

A

Activating Your Phone 8
Adding or Removing Programs 91
Answering Calls 73
Any key Answer 84
Auto Answer 84
Automated Invoicing Information
10
AvantGo Channels 132

B

Back up 179
Using a Memory Card 182
Using a Personal Computer 180
Backlight 97
Battery 16
Battery Life 22
Battery Operating Time 22
Charging the Battery 20
Installing the Main Battery 16
Removing the Main Battery 18
Block Recognizer 56
Browsing the Internet 133

C

Calendar 116
Call Forwarding 194
Call Guard 105
Call History 107
Erasing Call History 110
Making a Call From Call History
109
Saving a Phone Number From Call
History 109
Call History Options 109
Call Waiting 192
Caller ID 192
Calling Emergency Number 74
Camera 37, 153

Chatting With Contacts 141
ClearVue 160
Command Bar 49
Contacts 112
Customer Service Solutions 10

D

Dialer Screen 68
Directory Assistance 10
Displaying Your Phone Number 72
Drawing Mode 145
Drawing on the Screen 60

E

Email Messages 134
Email Server 134
End Button 39
Environment 83
Environment Switch 42
Environment switch status 47

F

FCC Notice 220
Full Reset switch 26

G

Getting Started with PCS Service 8

H

Hard Pause 69
Headset 36
Help 9

I

Infrared Communications Port 33
Initial Setup 45
Initialization 26
Input Panel 54

J

Jog Wheel 38

K

Key Guard Switch 41
Keypad Operation 68

L

LEDs 29
 Letter Recognizer 56
 Location Setting 81

M

Making a Call From Internal Phone Book 74
 Making Calls 73
 Maximum Battery Operating Time 23
 Memory 98
 Messaging 201
 Microphone 99
 Microsoft ActiveSync 174
 Microsoft Pocket Outlook 111
 Microsoft Reader 149
 MSN Messenger 139
 My Text 64

N

Navigation Bar 49
 Notes 122

O

Operator Services 10
 Owner's Record 246

P

PCS Business Connection 196
 PCS Directory Assistance 10
 PCS Operator Services 10
 PCS Service Features 187
 PCS Vision 195
 PCS Vision FAQs 201
 PCS Voice Command 204
 Accessing Information 205
 Creating Your Own Address Book 204
 Making a Call 205
 Picture Mail 197
 Pocket Excel 146
 Pocket Internet Explorer 130
 Pocket Word 142
 Pop-up Menus 53
 Power Save Feature 210

Programs 51

R

Radio Frequency Safety 210
 Reading a Book 150
 Recording a Message 62
 Recording Voice 127
 Regional Settings 101
 Reset button 25
 Resetting 25
 Review/Share 155
 Ring Type/Tone Settings for Individual Modes 82
 Ringer and Key Beep Settings 80
 Roaming 103
 How it works 104
 Roaming on Other PCS CDMA Networks 104
 Set Mode 104

S

SaiSuke 163
 Screen Brightness 44
 SD Card/ MultiMediaCard 34
 Setting Password 95
 Setting Up Your Voicemail 8
 Settings 90
 Signal Indicator 70
 Soft Keyboard 55
 Sounds & Notifications 96
 Speaker Phone 77
 Speaker Phone Button 39
 Specifications 244
 Speed Dial 75
 Status Icon 48, 71
 Stylus 44
 Synchronizing Email Messages 134

T

Talk Button 38
 Tasks 119
 Three-Way Calling 193
 Time Pause 70
 To convert writing to text 58
 To select a drawing 62
 To select writing 58

Today Screen 47
Transcriber 56
TTY 87
Turning Phone ON and OFF 72
Turning your Device ON and OFF 28

U

USB Cradle 30
USB Port 32
User Guide Proprietary Notice 246
Using the Keyboard 43

V

Voice Button 40
Voice Dial 76
Voice-Activated Dialing 126
Voicemail 188
Volume Button 40

W

Warranty 247, 248
Web 197
Windows Media Player 148
World Clock 162
Writing Mode 144
Writing on the Screen 57

