

MSM6050™ MOBILE STATION MODEM

QUALCOMM CDMA TECHNOLOGIES

[HTTP://WWW.CDMATECH.COM](http://www.cdmatech.com)

ENABLING THE FUTURE OF COMMUNICATIONS™

MSM6050™ MOBILE STATION MODEM

Overview

At QUALCOMM CDMA Technologies (QCT), we strive to constantly improve the indispensable communication tools we all use every day. QCT creates state-of-the-art chipsets, system software, development tools and products – such as the Launchpad™ suite of technologies and software – that support the most advanced digital wireless features and functionality available for wireless devices and base stations – while continually reducing complexity, cost and board-space requirements.

3G MSM6050 CDMA Chipset



The MSM6050™ solution, part of QCT's MSM6xxx™ Mobile Station Modem™ (MSM™) family of chipsets and system software, uses QCT's revolutionary radioOne™ Zero Intermediate Frequency (ZIF), or direct conversion, architecture to support Release A of the CDMA2000® 1X

standard, supporting data rates of up to 153 kbps on the forward and reverse links (FL and RL). The MSM6050 device, including the radioOne RF components, reduces the total number of radio components in half, shortens handset development and test times, simplifies RF calibration, and enables higher handset production yields. These features contribute to significantly reducing overall handset design and manufacturing costs as well as shortening time-to-market.

The MSM6050 CDMA2000 1X solution is optimized to support voice and key data capabilities while enabling CDMA2000 network benefits. It provides a seamless migration path from 2G to 3G services and applications, and the increased voice capacity of a CDMA2000 network. The MSM6050 solution will enable manufacturers to quickly develop handsets meeting specifications for worldwide cdmaOne™ and CDMA2000 1X systems.

The MSM6050 device significantly reduces radio bill-of-materials (BOM) costs and improves handset standby and talk times over current solutions. A key enhancement to the MSM6050 chipset over the previous generation is the integration of QCT's gpsOne™ position location technology. With the adoption of location-based services and the FCC E911 mandate for safety applications, the new generation of handsets based on the MSM6050 chipset will be able to provide cost-effective high accuracy position location capabilities.

The MSM6050 chipset solution consists of the MSM6050 baseband processor, direct conversion RFL6xxx™ and RFR6xxx™ receive devices, the direct conversion RFT6xxx™ transmit device, PM6xxx™ power management device and a compatible power amplifier device. These devices perform all of the signal processing and power management in the subscriber unit.

The MSM6050 chipset integrates functions that support tri-mode CDMA/FM handset operation. Subsystems within the MSM6050 baseband processor device include a CDMA processor, Digital FM (DFM) processor, QCT's latest generation of DSP, the QDSP4000™ core, for voice compression and applications support, PLL and an ARM® ARM7TDMI® microprocessor. Also integrated in the MSM6050 device are analog functions such as a wideband mono codec and analog interfaces for the radioOne RF ASICs. Controllers for a Universal Serial Bus (USB), device controller for a R-UIM (CDMA SIM), GPIOs, and peripheral interfaces complete the system integration.

QCT provides a complete software suite, Dual-Mode Subscriber Software™ (DMSS™), for building handsets around the MSM6050 chipset. DMSS software is designed to run on a Subscriber Unit Reference (SURF™) phone platform, an optional development platform optimized to assist in evaluating, testing and debugging DMSS software.

The MSM6050 device is offered in a 208-ball Fine-Pitch Ball Grid Array (FBGA) production package, which is package compatible with MSM6000™. This package compatibility gives handset manufacturers the ability to leverage re-use of the radioOne design with a range of handset models to address different market tiers.

Additionally, the MSM6050 solution supports QUALCOMM's Binary Runtime Environment for Wireless™ (BREW™) applications development platform.

As with all QCT products, the MSM6050 solution features the unparalleled customer support you have come to expect from your partner of choice for complete wireless communications solutions. QCT is committed to providing innovative multimode, multi-network chipsets, system software and development tools that will help ensure your competitive success in the wireless communications marketplace for 3G and beyond.

MSM6050™ MOBILE STATION MODEM

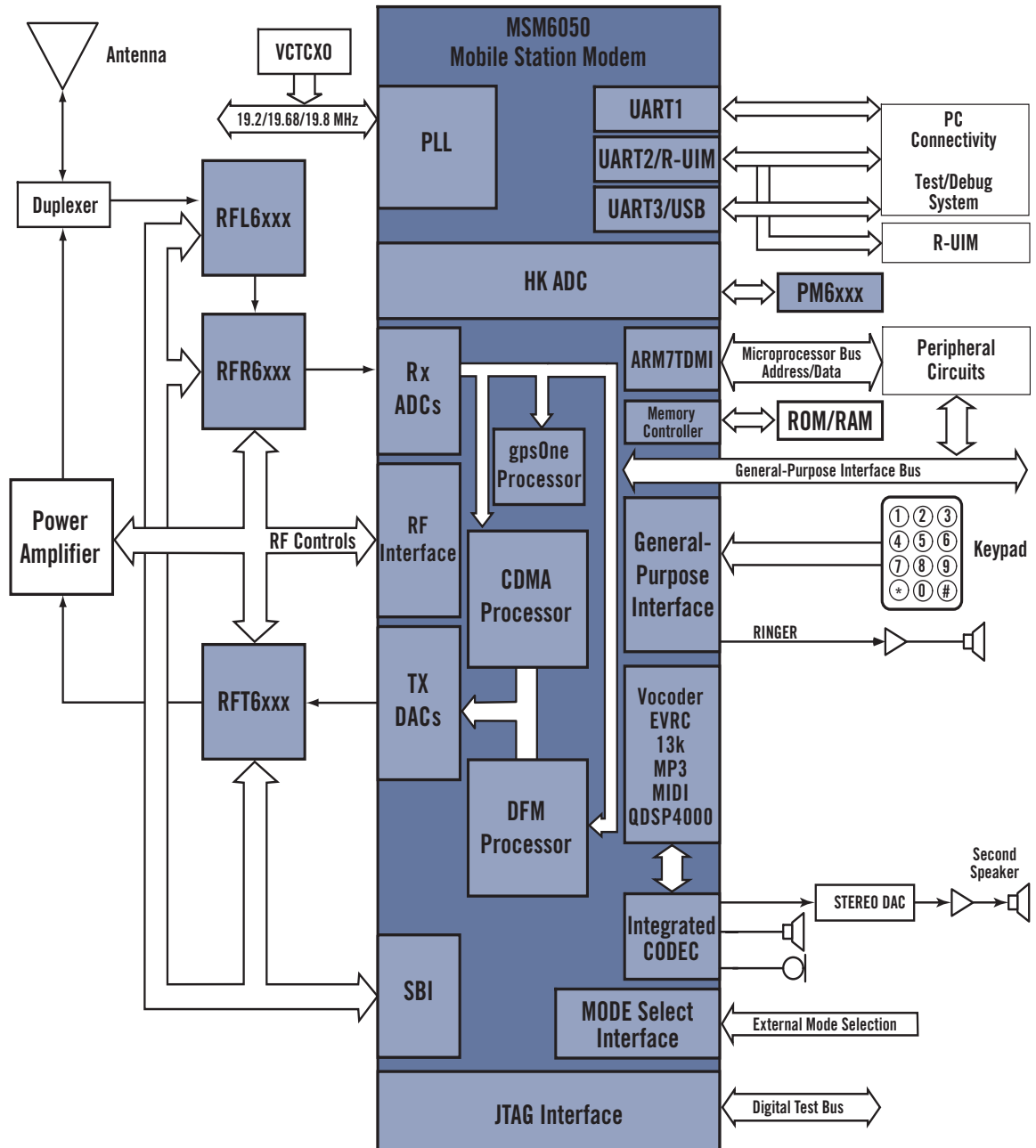

MSM6050 Functional Block Diagram

gpsOne Technology

QUALCOMM is introducing a new generation of its breakthrough gpsOne position location technology in the MSM6050 solution. Re-designed from the original MSM3300 IS-95A/B solution to provide a more optimized implementation, the gpsOne technology merges Global Positioning System (GPS) satellite and network information to provide a high-availability solution with industry-leading accuracy and performance to a new class of mainstream CDMA2000 1X handsets. This solution not only meets the FCC E911 mandate under the most challenging conditions, but also provides a ubiquitous platform for location-based applications and services.

The Mobile Station (MS) collects measurements from the GPS constellation and the cellular/PCS network, then sends the information to the Position Determination Entity (PDE), which optimizes the position location calculation based on existing information. gpsOne technology will enable consumer-priced, position-capable CDMA handsets.

The block diagram illustrates the baseline architecture for the MSM6050 and CDMA/GPS terminal devices.

radioOne Technology

The MSM6050 device interfaces directly with QCT's new radioOne RF ASICs. radioOne is a revolutionary technology for CDMA transceivers that uses Zero Intermediate Frequency (ZIF), or direct conversion, architecture for the wireless handset market. This direct conversion eliminates the need for large IF Surface Acoustic Wave (SAW) filters and additional IF circuitry, which significantly reduces the handset BOM, resulting in cost-effective multi-band and multimode handsets that can be produced in smaller form factors.

Using advanced techniques developed by QCT to enable high-dynamic-range receivers, radioOne solves the problem of stringent interference specifications with which CDMA phones must comply. The radioOne technology also incorporates the frequency synthesis and passive elements used in converting baseband signals to and from RF. A single external local oscillator is used for the CDMA receiver, which will provide the capabilities needed to operate on systems around the world and will simplify the procurement of parts and the cost of designing CDMA handsets.

MSM6050 Chipset Features

- Revolutionary radioOne architecture
- gpsOne position location capabilities
- CDMA2000 1X Release A support, offering data rates of up to 153 kbps on the forward and reverse links
- Tri-Mode (CDMA cellular, CDMA PCS, AMPS cellular)
- Vocoders support (EVRC, 13K QCELP®)
- PureVoice Voice Recognition™ (VR)
- Compact Media Extension™ (CMX™) multimedia software
- Qtunes™ audio decoder
- Moving Pictures Expert Group (MPEG) Layer-3 (MP3) support
- Standard MIDI ringer
- Universal Serial Bus (USB)
- Removable Universal Identity Module (R-UIM) card interface
- Integrated wideband mono voice codec
- Enhanced Memory support
 - 1.8 V
 - Page Mode Flash
 - NAND Flash memory interface
- 208 FBGA package

IS-2000 1X MC Features Supported by MSM6050 Chipset and Software Solution

- Fast 800 Hz forward power control
- Quasi-Orthogonal functions
- Supplemental channel (SCH) support
- CDMA2000 1X Forward Quick Paging channel (F-QPCH)
- Convolutional and turbo codes on SCH
- ITU 144 kbps requirements achieved
- Radio Link Protocol (RLP3)
- Quick paging channel
- CDMA2000 1X Release A



Copyright © 2003 QUALCOMM Incorporated. All rights reserved. QUALCOMM and QCELP are registered trademarks and service marks, and Launchpad, MSM6050, MSM6xxx, Mobile Station Modem, MSM, radioOne, cdmaOne, gpsOne, RFL6xxx, RFR6xxx, RFT6xxx, PM6xxx, QDSP4000, Dual-Mode Subscriber Software, DMSS, SURF, MSM6000, Binary Runtime Environment for Wireless, BREW, PureVoice Voice Recognition, Compact Media Extensions, CMX and Qtunes are trademarks of QUALCOMM Incorporated. All other trademarks contained herein are the property of their respective owners. Data subject to change without notice.
Printed in USA 10/2003 MSM6050-SS X7