

Free Copy

# TOEFL®

**2001**  
**2002**

## Information Bulletin for **COMPUTER-BASED TESTING**

YEAR-ROUND  
TESTING IN MANY  
LOCATIONS  
THROUGHOUT  
THE WORLD



CONVENIENT  
SCHEDULING



TEST OF ENGLISH  
AS A FOREIGN LANGUAGE™

**ETS**  
Educational  
Testing Service

The International Standard for Over 35 Years

<http://www.toefl.org>

POLICIES IN THIS *BULLETIN* ARE IN EFFECT FOR TEST APPOINTMENTS  
FROM JULY 1, 2001, TO JUNE 30, 2002.

READ THE INSTRUCTIONS IN THIS *BULLETIN* THOROUGHLY.  
KEEP THE *BULLETIN*. YOU WILL NEED IT FOR FUTURE REFERENCE.

# Table of Contents

<b>TOEFL — Test of English as a Foreign Language</b> .....	3	Concordance Tables .....	37
The Computer-Based Test .....	3	Viewing Scores at the Center .....	39
Testing at a Computer-Based Testing Center .....	4	Canceling Your Scores .....	39
Other Tests You May Need to Take .....	4	Examinee's Score Record, Official Score Reports .....	40
Test Preparation .....	4	Scores by Phone .....	41
<b>Testing and Service Fees</b> .....	5	Ordering Additional Official Score Reports for Institutions .....	42
Acceptable Forms of Payment .....	5	Score Verification .....	42
Payment Policies .....	5	Acceptable Scores .....	42
Refund Policy .....	5	Test Score Data Retention .....	42
<b>Appointment Scheduling for Testing in the United States, Canada, American Samoa, Guam, US Virgin Islands, and Puerto Rico</b> .....	6	Confidentiality of TOEFL Scores .....	42
Reschedule or Cancel a Testing Appointment .....	6	<b>ETS Score Cancellation Policy</b> .....	43
<b>International Appointment Scheduling for Testing Outside the United States, Canada, American Samoa, Guam, US Virgin Islands, and Puerto Rico</b> .....	7	<b>Test Centers</b>	
Reschedule or Cancel a Testing Appointment .....	8	United States, Canada, American Samoa, Guam, US Virgin Islands, and Puerto Rico .....	44
<b>Identification Requirements</b> .....	9	Outside United States .....	46
<b>Test Takers with Disabilities</b> .....	center of <i>Bulletin</i>	<b>Regional Registration Centers</b> .....	46
<b>Preparing for the Test</b> .....	11	<b>Institution Code List</b> .....	54
Test Structure .....	11	<b>Department Codes</b> .....	59
Guidelines for CBT Test Takers .....	11	<b>Country and Region Codes</b> .....	59
<b>Tutorials</b> .....	13	<b>Essay Rescoring Request Form</b> .....	60
<b>Sample Questions</b> .....	18	<b>Score Report Request Form</b> .....	61
<b>Writing Topics</b> .....	27	<b>Refund Request Form</b> .....	62
<b>Test Day</b> .....	33	<b>Where to Get Bulletins and Study Materials</b> .....	inside back cover
Admission to the Test .....	33	<b>To Reach TOEFL Services</b> .....	back cover
Test Center Procedures and Regulations .....	33	■ Applicant's Request for Nonstandard Computer-Based Testing Accommodations .....	center of <i>Bulletin</i>
Information Sharing Service .....	33	■ CBT Voucher Request Form .....	center of <i>Bulletin</i>
<b>Study Materials</b> .....	34	■ International Test Scheduling Form .....	center of <i>Bulletin</i>
<b>Scoring and Reporting Test Results</b> .....	36		
Writing Scoring Guide .....	36		
Comparing Test Scores .....	37		

The TOEFL program does not operate, license, endorse, or recommend any schools or study materials that claim to prepare people for the test in a short time or that promise them high scores on the test.

Other than the registration centers listed in this *Bulletin* (see pages 44-53), the TOEFL program does not operate, sponsor, license, or endorse any specific enterprise that provides local services to facilitate registration for the test. The TOEFL program is not responsible for the activities of such enterprises, and assumes no liability with regard to their failure to provide services.



Educational Testing Service is an Equal Opportunity/Affirmative Action Employer.



Copyright © 2001 by Educational Testing Service. All rights reserved.

EDUCATIONAL TESTING SERVICE, ETS, the ETS logos, Graduate Record Examinations, GRE, POWERPREP, PRAXIS, TOEFL, the TOEFL logo, TSE, and the TSE logo are registered trademarks of Educational Testing Service. College Board and SAT are registered trademarks of the College Entrance Examination Board. Graduate Management Admission Test and GMAT are registered trademarks of the Graduate Management Admission Council. The Test of English as a Foreign Language and the Test of Spoken English are trademarks of Educational Testing Service. GradAdvantage is a trademark of Educational Testing Service. Prometric is a registered trademark of Thomson Learning. VISA is a registered trademark of VISA International Service Association. MasterCard is a registered trademark of MasterCard International Inc. American Express and the American Express logo are registered service marks of the American Express Company. JCB is a registered trademark of JCB International Co., Ltd. Discover is a registered trademark of Morgan Dean Stanley Witter & Co.

Educational Testing Service (ETS) administers the test under the general direction of a board that was established by, and is affiliated with, the College Board and the Graduate Record Examinations Board. Prometric administers the computer-based TOEFL test at Prometric Testing Centers. No part of this publication may be reproduced or transmitted in any form or by any means, electronic or mechanical, including photocopy, recording, or any information storage and retrieval system, without permission in writing from Educational Testing Service, Princeton, NJ, USA. The fees, terms, and conditions in this Bulletin are subject to change.

# TOEFL®—Test of English as a Foreign Language™

The purpose of the TOEFL test is to evaluate the English proficiency of people whose native language is not English. In 1999-00, more than 348,417 people registered to take the computer-based test. TOEFL scores are required for purposes of admission by more than 2,400 two-and-four-year colleges and universities in the United States and Canada. The test is also used by institutions in other countries where English is the language of instruction. In addition, government agencies, scholarship programs, and licensing/certification agencies use TOEFL scores to evaluate English proficiency.

## THE COMPUTER-BASED TEST

The computer-based TOEFL test was introduced in July 1998 in many parts of the world. It combines many of the same question types as the traditional paper-based test with new question types that can be offered only on the computer.

**The test has four sections, all of which are mandatory.**

- **Listening** measures the ability to understand English as it is spoken in North America. This section tests comprehension of main ideas, supporting ideas, important details, and inferences. You will both see and hear the questions before the answer choices appear.
- **Structure** measures the ability to recognize language that is appropriate for standard written English. The language tested is formal, rather than conversational. When topics have a national context, they refer to United States or Canadian history, culture, art, or literature. However, knowledge of these contexts is not needed to answer the questions.
- **Reading** measures the ability to understand short passages similar in topic and style to academic texts used in North American colleges and universities. You will read a variety of short passages on academic subjects and answer several questions about each passage.
- **Writing** measures the ability to write in English on an assigned topic. **You must compose an essay in order to receive a total score.**

One difference between the computer-based test and the paper-based test is that some sections of the computer-based test are “computer-adaptive.” In computer-adaptive sections, questions are chosen from a very large pool of questions that are categorized by difficulty and content. The questions are chosen by the computer based on how you answer the previous questions. For instance, the first question you receive in a computer-adaptive section will be of average difficulty. The question you receive next will generally be one that best fits your performance (how well you did on the previous question) and the design of the test. The test design for both paper and computer assures that all test takers will be tested on similar skills (e.g., comprehension of main idea, understanding of inferences) and subject matter (a variety of topics for lectures and passages). **The scores of all test takers, at all ability levels, are based on the same number of questions. Pretest questions, used for research purposes, may be included in the test, but your answers to these questions are not scored.**

In the TOEFL computer-based test, the Listening and Structure sections are adaptive. In these sections, you will be able to change your answer as often as you like until you have made your final choice, confirmed your answer, and moved on to the next question. You will not be allowed to go back to a previous question, because your answers to all previous questions help determine the difficulty level of the next question given.

The Reading section of the test is not adaptive. This section is similar to that of the paper-based test in that you will receive passages and accompanying sets of questions. Because the selection of these passages and questions will not be based on your performance, you will be allowed to omit items or go back to previous questions.

In the Writing section, the computer will assign you a topic from a pool of topics (see pages 27-32 for the topics in the pool). You will have the choice of handwriting your response or typing it on the computer.

<http://www.toefl.org>

*Visit the TOEFL Web site to order TOEFL study materials and receive updated testing information.*



## TESTING AT A COMPUTER-BASED TESTING CENTER

Prometric®, a division of Thomson Learning, administers the computer-based test year-round at permanent testing centers throughout the world. In addition, testing is offered at supplemental centers on specific dates or during specific time periods. For testing at supplemental centers, you must obtain the *Information Bulletin for Supplemental TOEFL Administrations* from the institution where you obtained this *Bulletin*, institutions listed on the inside back cover of this *Bulletin*, or TOEFL Services (see back cover for addresses and telephone numbers). Before you attempt to schedule a testing appointment, check pages 44-53 carefully for the type and availability of centers in your area.

Every test center is open to every properly registered person regardless of race, color, creed, or national origin.

## OTHER TESTS YOU MAY NEED TO TAKE

- Test of Spoken English™ (TSE®) — The TSE test evaluates the general oral language proficiency of nonnative speakers of English. It is not available in a computer-based format.

If you need to take the TSE test, you must obtain a *TSE Information Bulletin*. Write to TOEFL/TSE Services, P.O. Box 6154, Princeton, NJ 08541-6154, USA, or call 1-609-771-7100. You may also obtain a *TSE Bulletin* from locations that distribute the TOEFL *Bulletins*. For up-to-date information about the TSE program, visit the TOEFL Web site at <http://www.toefl.org>.

- Undergraduate schools may ask you to take the College Board admissions tests — the SAT I: Reasoning Test and SAT II: Subject Tests. For further information, visit College Board Online at <http://www.collegeboard.org>.
- Graduate schools may require you to take the Graduate Management Admission Test® (GMAT®) or the Graduate Record Examinations® (GRE®). For further information, visit GRE Online at <http://www.gre.org>. GMAT information is available by accessing its Web site at <http://www.gmac.org>.

If you cannot get information bulletins locally for these tests, write to Educational Testing Service, Princeton, NJ 08541-0001, USA.

<http://www.toefl.org>

Check our Web site for details on TOEFL Web registration.

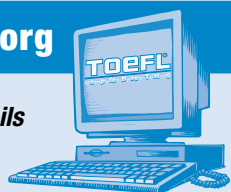

## WHAT ARE CONDITIONS LIKE AT THE TEST CENTER?

The test is given in individual testing stations, similar to partitioned study areas you might find in a library. You will be given headphones for the Listening section.

## WHAT COMPUTER SKILLS DO I NEED?

You can take the test even if you have no previous computer experience. You are required to complete tutorial sections on the computer before the test begins (see pages 13-17). These sections teach the computer skills you will need for taking the test.

## HOW CAN I PREPARE FOR THE COMPUTER-BASED TEST?

**Before** the day of the test, you may view the tutorials for **free** at [www.toefl.org/cbtutprq.html](http://www.toefl.org/cbtutprq.html). They are also available in the following priced study products.

**POWERPREP® Software** — This CD-ROM contains two practice tests developed from a pool of more than 1,200 questions.

**TOEFL Sampler** — An instructional CD-ROM with the same animated tutorials presented during the actual test. The 67 practice questions and Listening review material provide the basics for learning about the computer-based test.

For more information about these products, see pages 34-35. Also read pages 13-26 for information about the tutorials, sample questions, and descriptions of the test sections.

**NOTE:** No single school, textbook, or teaching method is best to help prepare someone for TOEFL because the test is not based on specific courses of study. Language proficiency and writing ability can only be achieved after a relatively long period of study and practice. An attempt to study English for the first time shortly before taking the test will not be very helpful.

## Testing and Service Fees

Computer-Based TOEFL Test .....	US\$110
Rescheduling fee .....	US\$40
Additional Score Report Requests .....	US\$12
(per recipient)	
Essay rescore .....	US\$50
Reinstatement of canceled scores .....	US\$10
Fee for returned check and declined credit card .....	US\$25

**In Canada, add GST/HST, Reg. #13141 4468 RT, to total remittance. Taxes will be added where applicable. Fees are subject to change without notice.**

### PAYMENT POLICIES

All test payments must be made in full, be dated within 90 days of the date of receipt at the RRC, have the correct numeric and written dollar amount, and have appropriate signature(s). Post-dated checks will not be accepted. Checks, bank drafts, money orders, and Eurochecks in US dollars must be drawn on a bank in the US. The bank name and its address should be preprinted on the face of the check. Checks in Canadian dollars must be drawn on a bank in Canada at the prevailing rate of the US dollar plus GST/HST. See pages 6-7 for instructions for submitting your payment. Services may be withheld for nonpayment of fees. **If you do not submit the correct fee, your registration or request for service will be returned. Scores will not be released if a payment is returned for any reason.**

#### Payments made in the following currencies must be made at the Telegraphic Transfer Selling (TTS) exchange rate of the US dollar equivalent.

Checks, money orders, or Eurochecks payable in these currencies must be drawn on a bank in the same country as the currency. For example, a check written in French francs must be drawn on a bank in France.

- |                      |                         |
|----------------------|-------------------------|
| ■ Australian Dollar  | ■ Kuwaiti Dinar         |
| ■ Austrian Schilling | ■ Malaysian Ringgit     |
| ■ Belgian Franc      | ■ Mexican Peso          |
| ■ British Pound      | ■ Netherlands Guilder   |
| ■ Canadian Dollar    | ■ New Zealand Dollar    |
| ■ Danish Kroner      | ■ Norwegian Kroner      |
| ■ Egyptian Pound     | ■ Papua New Guinea Kina |
| ■ Euro               | ■ Philippine Peso       |
| ■ Fiji Dollar        | ■ Portuguese Escudo     |
| ■ Finnish Markka     | ■ Saudi Riyal           |
| ■ French Franc       | ■ Singapore Dollar      |
| ■ German Deutschmark | ■ South African Rand    |
| ■ Greek Drachma      | ■ Spanish Peseta        |
| ■ Hong Kong Dollar   | ■ Swedish Krona         |
| ■ Indian Rupee       | ■ Swiss Franc           |
| ■ Indonesian Rupiah  | ■ Taiwan Dollar         |
| ■ Irish Punt         | ■ Thai Baht             |
| ■ Italian Lira       | ■ Venezuelan Bolivar    |
| ■ Japanese Yen       |                         |



### ACCEPTABLE FORMS OF PAYMENT

**IF TESTING IN THE UNITED STATES, CANADA, AMERICAN SAMOA, GUAM, US VIRGIN ISLANDS, OR PUERTO RICO**

- Check made payable to **ETS-TOEFL**
- Credit card — VISA® , MasterCard® , or American Express® 
- Money order
- Bank draft (certified check)
- US postal money order
- International money order
- Authorization voucher

### ACCEPTABLE FORMS OF PAYMENT

**IF TESTING OUTSIDE THE UNITED STATES, CANADA, AMERICAN SAMOA, GUAM, US VIRGIN ISLANDS, OR PUERTO RICO**

- Check made payable to **ETS-TOEFL**. Submit it to your Regional Registration Center (RRC). See page 46.
- Credit card — VISA , MasterCard , or American Express 
- Money order
- Bank draft (certified check)
- US postal money order
- International money order
- UNESCO coupons
- Eurocheck in Europe (drawn on a bank in the country of the currency)
- Currencies listed in the left-hand column
- Authorization voucher

### REFUND POLICY

A partial refund of US\$65 is available if you cancel your appointment within the proper time period (see page 6 or 8) or have paid for a CBT voucher but have not used it.

- Complete the Refund Request Form on page 62.
- Your Refund Request Form must be received within 60 days after your canceled appointment or voucher expiration date.
- If you received a CBT voucher, return it with the completed request form.
- Mail the form to TOEFL Services, Educational Testing Service, PO Box 6151, Princeton, NJ 08541-6151, USA, or fax it to 1-609-771-7500.
- Credit card accounts will be credited.
- Allow 10 weeks for receipt of refund.
- Refunds are made in US dollars.

# Appointment Scheduling for Testing in the United States, Canada, American Samoa, Guam, US Virgin Islands, and Puerto Rico

## SCHEDULE BY PHONE

- Use a VISA, MasterCard, or American Express credit card or CBT voucher number (see “How to Get a CBT Voucher” to the right).
- Call the test center directly (see test center locations, pages 44-45) or Prometric Candidate Services Call Center at **1-800-GO-TOEFL** (1-800-468-6335). Call 1-443-751-4862, if you currently live *outside* the United States but want to test at a center in the United States. (The cost of this long distance call will be added to your telephone bill.) If you are hearing impaired and use a **TTY**, call 1-800-529-3590.

When you call, the registrar will ask for the information that appears on the CBT Voucher Request Form (center of *Bulletin*).

You will be given an appointment confirmation number, test date, reporting time, and test center address when you call. Write down your confirmation number because you will not receive a letter with this information. Be sure to see pages 9 and 10 for details about identification documents.

**NOTE: If you schedule by phone, DO NOT mail or fax the form or you will be scheduled and billed for two different appointments. Once you have made an appointment over the phone, the scheduling process is complete.**

## WALK-IN SCHEDULING

- You can try to schedule an appointment by walking into a test center on the day you want to test, or you may go to schedule an appointment in advance. You are not guaranteed a walk-in appointment; unscheduled examinees are admitted on a first-come, first-served basis after scheduled candidates. The test center administrator will let you know if you can test.
- Use a valid (not expired) TOEFL CBT voucher or any other form of payment stated on page 5 under “Acceptable Forms of Payment.”
- If paying with a TOEFL CBT voucher, you must present it when scheduling your appointment.
- You must also take your valid passport or other acceptable identification documents (see pages 9 and 10 for details about identification requirements).

### Scheduling Hints

- Make your appointment early; test centers fill up quickly.
- Take the test as soon as possible so your scores will be received in time to be considered with your application.
- Appointments are not transferrable. You are not allowed to give your testing appointment to someone else.

You will **not** be admitted if you do not have the proper ID. See pages 9 and 10.

## HOW TO GET A CBT VOUCHER

- Use a check or money order payable to ETS-TOEFL (see “Acceptable Forms of Payment” on page 5) or an American Express, Discover, JCB, MasterCard, or VISA credit card.
- Complete the CBT Voucher Request Form (center of *Bulletin*).
- Mail your payment (or credit card information) and CBT Voucher Request Form in the envelope in the center of the *Bulletin*. Use the “CBT Voucher Request Form” mailing label attached to the envelope. If the label is missing, mail the form to CBT Voucher

Request Form, Educational Testing Service, P.O. Box 6159, Princeton, NJ, 08541-6159, USA.

- **WAIT two to four weeks for your voucher to be processed and mailed to you.**
- Once you receive your voucher, call to schedule an appointment. Do **not** call before you receive your voucher. If you do, you will be scheduled twice. The voucher will have a 16-digit number that you will use when you call to schedule.
- Follow the “Schedule by Phone” procedures.

CBT vouchers are valid for one year from the date of issue. If you do not receive your CBT voucher or if you have lost it, call 1-609-771-7100 or

send an email to [toefl@ets.org](mailto:toefl@ets.org).

## RESCHEDULING OR CANCELING

- Contact the test center or Prometric Candidate Services Call Center at 1-800-GO-TOEFL (1-800-468-6335) no later than three business days before your appointment. If canceling an appointment, you must call within the specified time frame to receive a partial refund.
- You will be charged US\$40 for rescheduling your appointment.
- You must provide your appointment confirmation number and the full name you used to make an appointment when you call.

**In rare instances, technical problems may require late starts and/or rescheduling of your test. ETS is not liable for any inconvenience, expense, or other personal damages incurred by examinees because of a late start, rescheduled test, or delay in the reporting of scores.**

# International Appointment Scheduling for Testing Outside the United States, Canada, American Samoa, Guam, US Virgin Islands, and Puerto Rico

## SCHEDULE BY PHONE

- Use a VISA, MasterCard, or American Express credit card.
- Call the appropriate Regional Registration Center [RRC] (see page 46) at least three business days prior to your preferred test date. When you call the RRC, the registrar will ask for all the information that appears on the International Test Scheduling Form (center of *Bulletin*).

You will be given an appointment confirmation number, test date, reporting time, and test center address when you call. Write down your confirmation number because you will not receive a letter with this information. Be sure to see pages 9 and 10 for detailed information about the ID documents required.

**NOTE: If you schedule by phone, DO NOT mail or fax the form or you will be scheduled twice and billed for two different appointments. Once you have made an appointment over the phone, the scheduling process is complete.**

## SCHEDULE BY FAX

- Use a VISA, MasterCard, or American Express credit card.
- On the International Test Scheduling Form, indicate your first five date choices by month and day, the test center number, and the name of the city where the center is located.
- Fax the International Test Scheduling Form to the appropriate RRC (see page 46). Do not fax the form twice. If you do, you will be scheduled and charged twice.
- Your form and credit card information must be received at least seven days prior to your first choice test date. For example, if you choose the first Monday in August (August 6), your form must be received by the appropriate RRC by July 30.

You will be assigned a test date, time, and location based on the information you provide. If no appointments are available, you will be assigned to a date as close as possible to your choices. If your assigned test date does not meet your needs, contact the RRC within 24 hours of receipt of the letter notifying you of your appointment.

An appointment confirmation number, test date, reporting time, test center location, and instructions about the identification documents you must take to the test center will be faxed, mailed, or emailed to you. **If you do not receive an appointment confirmation number, call the RRC three business days prior to your first-choice test date to confirm your appointment status. If you miss your appointment, you will forfeit your test fee.**

### Scheduling Hints

- Make your appointment early; test centers fill up quickly.
- Take the test as soon as possible so your scores will be received in time to be considered with your application.
- Appointments are not transferable. You are not allowed to give your testing appointment to someone else.

You will **not** be admitted if you do not have the proper ID. See pages 9 and 10.

## SCHEDULE BY MAIL

- Use a check or money order, payable to ETS-TOEFL (see “Acceptable Forms of Payment” on page 5), OR a VISA, MasterCard, or American Express credit card.
- On the International Test Scheduling Form, indicate your first five date choices by month and day, the test center number, and the name of the city where the center is located.
- Mail the International Test Scheduling Form with proper payment, including any applicable taxes, in the envelope provided (center of *Bulletin*) to the appropriate RRC (see pages 46-53). **The form must be received at least three weeks prior to your first choice test date.** For instance, if you choose the first Monday in August (August 6), your form must be received by July 16 at the appropriate RRC.

## HOW TO GET A CBT VOUCHER

- See page 6 for instructions.

(Continued on page 8)

## International Appointment Scheduling (continued)

You will be assigned a test date, time, and location based on the information you provide. If no appointments are available, you will be assigned to a date as close as possible to your choices. If your assigned test date does not meet your needs, contact the RRC within 24 hours of receipt of the letter notifying you of your appointment.

An appointment confirmation number, test date, reporting time, test center location, and instructions about the identification documents you must take to the test center will be faxed, emailed, or mailed to you. **If you do not receive an appointment confirmation number, call the appropriate RRC three days prior to your first-choice test date to confirm your appointment status. If you fail to call the RRC and you miss your appointment, you will forfeit your test fee.**

## RESCHEDULING OR CANCELING

- Contact the RRC no later than three business days before your appointment for a permanent center and at least five days before your appointment for a center with limited testing or your full test fee will be forfeited.
- You will be charged US\$40 for rescheduling your appointment.
- You must provide your appointment confirmation number and the full name you used to make an appointment when you call.
- Appointments cannot be rescheduled between sites served by different RRCs, for example, Paris, France to Melbourne, Australia.

**In rare instances, technical problems may require late starts and/or rescheduling of your test. ETS is not liable for any inconvenience, expense, or other personal damages incurred by examinees because of a late start, rescheduled test, or delay in the reporting of scores.**

### HOW OFTEN CAN I TAKE THE COMPUTER-BASED TOEFL TEST? IF I CANCEL MY SCORES, CAN I TAKE THE TEST AGAIN?

TOEFL policy states that you may take the computer-based TOEFL test only once in any calendar month, even if you took the test and canceled your scores. For example, if you test in July, you must wait until August to take it again. If you test more than once in a calendar month, your new scores will not be reported and your test fee will not be refunded. Violation of this policy may also result in additional action being taken.

### HOW COMPARABLE ARE SCORES EARNED ON THE COMPUTER-BASED TOEFL TEST WITH THOSE EARNED ON THE PAPER-BASED TEST?

Because of changes in the content and format of the TOEFL test, scores on the computer-based TOEFL test are reported on a different scale than on the paper-based test. The paper-based TOEFL test will continue to be administered in certain parts of the world, and scores on the paper-based test will be reportable for two years after an administration. Although scores on the paper-based TOEFL test and the computer-based TOEFL test are not directly comparable, the concordance table on page 37 enables examinees and institutions to make judgments about English language proficiency in critical score ranges.

**NOTE: Only ETS can answer questions about score comparability or any other score-related questions.**

## INFORMATION SHARING SERVICE

When you register for a TOEFL test, you are automatically included in the free TOEFL Information Sharing Service. This service can help you learn more about US colleges and universities that are searching for you. Participating institutions are sent the names of prospective students whose backgrounds match the institutions' specifications. TOEFL scores are not included with the background information sent to institutions. Prospective students are mailed information about the institution(s). If you do not wish to participate, indicate "no" when answering the background questions during your testing session.

<http://www.toefl.org>

**Check our Web site for details on TOEFL Web registration.**

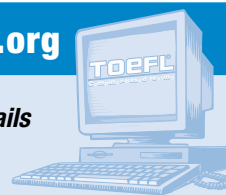

# Identification Requirements

**All test takers must read the following important information.**

Identification requirements for TOEFL test takers are strictly enforced. It is your responsibility to read the following instructions and understand the requirements. If you arrive at the test center without the required identification, the test center administrator will not admit you, you cannot test, and you will lose your test fee. You must contact the ETS Test Security Office **before scheduling an appointment or registering for the test** if you are

- a refugee
- an immigrant or registered resident alien and do not have a passport
- on active military service outside your own country and do not have a passport
- unable to meet the specified identification requirements for any other reason

You can reach the Test Security Office by phone at 1-609-406-5430, by fax at 1-609-406-9709, or by email at [TSReturns@ets.org](mailto:TSReturns@ets.org).

Test center personnel will check your identification before assigning you a seat at the test center. You will be asked to sign the test center log and fill in the time. The administrator will check your signature to verify that you are the person in your photo identification. The administrator will repeat this procedure before and after all breaks.

The TOEFL program will report scores only in the name shown on the official identification document that you present at the test center. Make sure to use that name when scheduling your appointment. If the name on your official identification does not match the name on your appointment record, you will not be permitted to test. **Only misspellings of your name can be corrected at check-in — NAME CHANGES WILL NOT BE MADE. If your name has changed for any reason, including marriage, it will be your responsibility to resolve the difference with your selected institution(s).**

If the passport or other acceptable official identification does not contain your signature, you must either sign the document or present an additional identification document from the *secondary identification* list below. The second document must contain a recent, recognizable photo and your signature.

You may need to provide additional proof of identity if the test center administrator questions the identification documents that you present. If positive confirmation cannot be made, the test center administrator can refuse to admit you to the test center.

**All test takers in Bangladesh, India, and Pakistan must present valid passports.**

**TEST TAKERS TESTING WITHIN YOUR COUNTRY OF CITIZENSHIP** — You must present one of the following identification documents. The document must be valid and contain a recent, recognizable photograph and your signature.

- passport
- driver's license
- national identification card
- military identification card

If none of your documents from the above list contains both a photo and a signature, you must present a second document from the secondary identification list below. One of the documents must contain a recent, recognizable photo and one must contain

your signature. (You may choose to sign the document in order to meet the requirements.)

## Secondary Identification Documents

- passport
- driver's license
- national identification card
- military identification card
- student ID
- **confirmation of identity letter**

**The letter must contain your date of birth, a recent, recognizable photograph, and your signature. It must be typed on the original letterhead of the educational institution you attend(ed), and the signature of the school official and the school seal must overlap your photograph (see sample on page 10).**

## TEST TAKERS TESTING OUTSIDE OF YOUR COUNTRY OF CITIZENSHIP

— You **MUST PRESENT YOUR PASSPORT** (citizens of European and Schengen Treaty countries see special requirements below). Refugees, resident aliens, and military personnel should review the instructions in the first paragraph above. If you do not present the required identification for noncitizens, TOEFL/ETS may automatically cancel your test scores.

If your passport is not written in the Latin alphabet (English language letters), you must also present another document from the *secondary identification* list above. The second document must also contain a recent, recognizable photo and must be in English.

If your passport does not contain your signature, you must either sign your passport or present an additional identification document from the *secondary identification* list above that does contain a signature.

## European Union/Schengen Zone Countries

If you are taking the test within another European Union or Schengen Treaty country, you may use your valid national or European identity card if you have one. The card you present must contain a recent, recognizable photograph, your date of birth, and your signature. If your document does not meet all of these requirements, you must also present another document from the *secondary identification* list above.

## UNACCEPTABLE IDENTIFICATION DOCUMENTS

- identification without photo
- expired passport
- expired driver's license
- Social Security card
- draft classification card
- credit card
- notary-prepared letters or document
- employee identification card

Admittance to the test center does not imply that your identification is acceptable or that the TOEFL program will report your scores. All reported cases of questionable identification are subject to review and approval by the ETS Test Security Office. If you have any questions about meeting the above requirements, contact the ETS Test Security Office by phone at 1-609-406-5430, by fax at 1-609-406-9709, or by email at [TSReturns@ets.org](mailto:TSReturns@ets.org).

If you present a letter as an identification document, it must be an original letter, not a photocopy of a letter, and it must contain items 1-9 as shown below.

For use in the United States, American Samoa, Guam, Puerto Rico, and US Virgin Islands ONLY	SAMPLE LETTER OF IDENTITY	All areas OUTSIDE the United States, American Samoa, Guam, Puerto Rico, US Virgin Islands and Canada
<ol style="list-style-type: none"> <li>(1) Official letterhead of your school or sponsoring agency (school for US citizens, sponsoring agency for refugees in the United States).</li> <li>(2) Your name as it appears on the proof of status that you must take to the test center. Remember, when you schedule an appointment and when you take the test, you must use the same name that appears on your proof of status.</li> <li>(3) Your date of birth.</li> <li>(4) Your citizenship or immigrant or refugee status. (This space must state that you are a citizen of the United States, or an immigrant or a refugee and the name of the country you are from.)</li> <li>(5) Name of the school or sponsoring agency. (This space must state that you are or were a student at the school or that you are a refugee sponsored by an agency.)</li> <li>(6) Your photograph, glued to the letter.</li> <li>(7) The seal of your school or sponsoring agency, overlapping your photograph.</li> <li>(8) The signature and title of the official who issued the letter, overlapping your photograph.</li> <li>(9) Your signature.</li> </ol>	<p style="text-align: center;">(1) Official Letterhead</p> <p>I verify that (2) _____,          whose date of birth is (3) _____, is a          (4) _____ (and is a) / (at)          (5) _____ and          his/her photograph and signature are shown on          this letter.</p> <div style="text-align: center;"> <p style="text-align: center;">(7)</p> <p style="text-align: center;">(6)</p> <p style="text-align: center;">(8) <i>Signature of Official</i> <i>Title of Official</i></p> <p>I attest that the above          information is true.</p> <p>(9) _____</p> </div>	<ol style="list-style-type: none"> <li>(1) Official letterhead of your school.</li> <li>(2) Your name. Remember, when you schedule an appointment and when you take the test, you must use the same name that appears on your letter of identity.</li> <li>(3) Your date of birth.</li> <li>(4) Your affiliation with the school. (This space must state that you are or were a student at the school.)</li> <li>(5) Name of the school.</li> <li>(6) Your photograph, glued to the letter.</li> <li>(7) The seal of your school, overlapping your photograph.</li> <li>(8) The signature and title of the official who issued the letter, overlapping your photograph.</li> <li>(9) Your signature.</li> </ol>

## Test Structure

The entire test session is approximately four hours long. This includes time spent on the four sections of the test as well as on tutorials that examinees are required to view on their test day. The tutorials teach different computer skills needed to take the test and describe how to answer questions in each test section. On average, most test takers take about 40 minutes to complete the tutorials.

The scores of all test takers are based on the same number of questions. However, because additional questions (used for research purposes only) are randomly distributed in tests, the number of questions in each section and the time allowed to complete each section may vary. The total amount of time allowed for a section is stated in the directions. The time allowed to respond is displayed at the beginning of each section. You should look at this information before beginning each test section.

The current question number, the total number of questions in the section, and the time remaining in the section are displayed on the title bar (see sample title bar on page 14). The information on the title bar changes as you proceed through a section. For example, you may see question 5 of 20 and 00:17 minutes remaining, or you may see question 13 of 20 and 00:08 minutes remaining. Use this information to check your progress so that you will finish all the questions before time runs out.

The number of questions in the Listening section may range between 30 and 49. The Structure section may range from 20 to 25 questions. The Reading section may range from 44 to 55 questions.

Because the number of questions may vary, the amount of time given for each section will vary. In the Listening section, you will be given 15 to 25 minutes to answer the questions. The clock runs while you are answering questions and any time you adjust the volume. It does not run while you are listening to the conversations and talks. The actual amount of time it will take to complete the Listening section is about 40 to 60 minutes. In the Structure section, you will be given between 15 and 20 minutes to complete the questions. In the Reading section, you will be given 70 to 90 minutes to complete the section. This includes the time spent reading the passages and answering the questions.

In the Writing section, you **must compose an essay** based on the one topic assigned randomly from a large pool of topics. Although the entire pool of topics is published (see pages 27-32), it is important to remember that you must write only on the assigned topic. **An essay on any other topic will be scored a 0. Once you are presented with your topic, do not click on Next/Confirm Answer until you have finished typing.** You will be given 30 minutes to complete your essay.

**NOTE: You must answer at least one question in each section and compose an essay to receive an official score report.**

## GUIDELINES FOR CBT TEST TAKERS

We strongly urge you to carefully review the following information as you prepare for your test and before you arrive at the test center. It could help improve your chances for success.

- **Learn about the test.** It's always best to know as much as possible about what to expect **before** you arrive at the test center. **Some sections may NOT be computer-adaptive.**
- **Once you know what to expect on your test, it's time to practice.** At a minimum you should do some **sample questions** from each section of the test to get familiar with them. Sample test questions can be found on pages 18-26 or on the TOEFL Web site at **www.toefl.org**. You can also purchase test preparation materials (see pages 34-35).
- When practicing for the test, try to simulate test-taking conditions as much as possible. For example, you will be given scratch paper only for the Writing section. Try not to use scratch paper when you practice for the other sections.
- **Try practice test questions under timed conditions so that you get used to the pace of the test.** In other words, if there are 20 questions in a section and you have a total of 40 minutes to complete the section, give yourself **an average** of two minutes to complete each sample question. When you are practicing, keep your time in mind and remember that **if you spend too much time on one question, you will have less time to spend on others.**
- **Use the computer tutorial to your advantage.** When you arrive at the test center on test day you must complete a computer tutorial before the actual test begins. You can spend **as much time as you need** to make yourself familiar and comfortable with the computer **before** you start the timed sections of the test. Don't start until you are ready. Once the test is under way, you can always click on "Help" to review the directions or a summary of the tutorial again, but be aware that **this will count against your allotted time** for that section of the test.

You can also download the tutorial for free from the ETS Web site at **www.ets.org/cbt\_demo.html**.
- **Pace yourself.** Use the *Bulletin*, Web site, test preparation material, software, or CDs to become familiar with the test and test instructions **before** you get to the test center. Read the directions carefully before you begin. The directions at the beginning of each test section tell you the total number of questions in that section as well as total time allotted for that section. Try to budget enough time for each question so you will be able to complete the test without having to rush at the end of each section. Keep in mind the average amount of time you may want to spend per question. Once you start the test, an onscreen clock

display will continuously count down the remaining time. You can hide this display if you want, but it is a good idea to check the clock periodically to monitor your progress. The clock will alert you when 5 minutes remain in the allotted time for that section.

- **Use your time wisely.** Read each question carefully. Eliminate the wrong answers and select the best choice. Don't let yourself get stuck on a tough question and lose time. Keep moving through the test and try to finish each section.
- **Computer-adaptive tests require that you answer every question in the order it is presented.** You cannot skip a question and go back. The computer selects the next question you see from a large pool of available questions based upon your previous responses.
- **Computer-adaptive tests are scored differently than most paper-and-pencil tests.** Your score depends on such factors as
  - the number of questions you answered within the allotted time
  - your performance on questions answered throughout the test
  - the level of difficulty of those questions in relation to your overall performance at that point in the test
- **Do not spend too much time on any one question.** If, after you've given a question a reasonable amount of thought, you still don't know the answer, eliminate as many answer choices as possible and then select and confirm the answer you think is best.
- **If you are running out of time at the end of a section, make every effort to complete the test.** Data indicate that on average most candidates get higher scores if they **finish** the test. In fact, based on analyses of test takers, a majority of test takers will score higher if they finish the test than if they do not attempt to answer all the questions. However, there is a chance that guessing at the end of the test can seriously lower your score. The best strategy is to pace yourself so that you have time to consider each test question, so you don't have to guess.
- Read each question carefully and thoroughly. Before answering a question, determine exactly what is being asked. Always read and understand all possible answers. If you do not, you may miss important information.
- Remember that if you exit the test, you will **NOT** be able to return to it.

## Listening Section

- Try to answer as quickly as you can so what you listened to remains fresh in your mind.
- Read the questions as well as listen to them.
- After listening to and reading the questions, try to think of the answers before looking at the options. Then quickly scan the options and find the one that matches your prediction.
- Use the visuals that accompany the conversations and talks. They contain important information.

## Listening and Structure Sections

- You must answer each question in the Listening and Structure sections (the computer-adaptive sections). You cannot skip questions or go back and change answers. If you do not know the answer to a question, first eliminate any answer choices that are obviously incorrect before making a guess. Confirm your answer only when you are certain you are ready to move to the next question. Random guessing could lower your score.

## Reading

- Read each passage carefully before answering the questions.
- In the Reading section, you can return to questions and change your answers. You can also skip a question and return to it later.
- To use your time well, it is best to answer all the questions about one reading passage before going on to the next one.

## Writing Section

- Become familiar with the list of writing topics on pages 27-32. When you take the test, you will **not** have a choice of topics.
- Before taking the test, practice writing several 30-minute essays using the topics on pages 27-32.
- Decide before you take the test whether to **handwrite** or **type** your essay. If you decide to type it, use the *TOEFL Sampler* (see pages 34-35) to become familiar with the word processing program. Remember that if you decide to **handwrite** your essay, you must write it on the single page, two-sided essay form you will be given at the test center.
- Essay readers judge how well details, examples, and reasons support or illustrate the points being made.

**NOTE:** If you **handwrite** your essay, your scores will be **mailed** from ETS approximately **five weeks** after the test date. If you **compose** the essay on the computer, your scores will be **mailed** from ETS **approximately two weeks** after the test date.

# Tutorials

On the day of the test, you will look at several tutorials. The tutorials will teach you basic computer skills and how to answer test questions. The tutorials are not scored, and you can spend as much time as you need on them. Before the test begins, you will be shown:

- How to use a mouse
- How to scroll
- How to use the testing tools

Before each of the four sections of the test, you will be shown how to answer the types of questions within the section:

- Listening
- Structure
- Reading
- Writing

The screens below show examples of some of the screens in the actual tutorials. You can also find the tutorials on the TOEFL Web site at <http://www.toefl.org>.

## HOW TO USE A MOUSE

You will use the mouse to answer the test questions. When you move the mouse with your hand, the pointer moves on the computer screen.

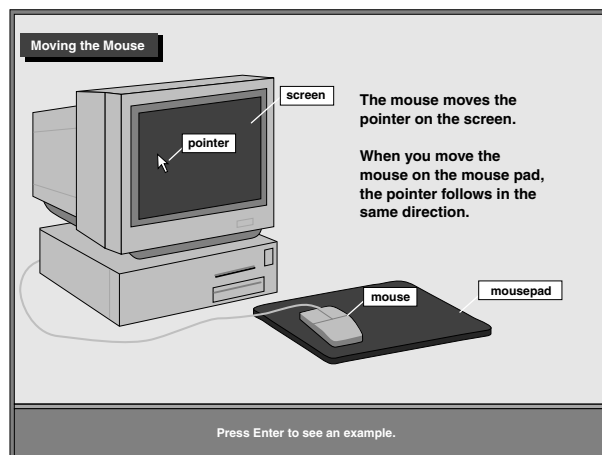

To answer most questions, you will use the mouse to move the pointer to the answer. Then, you will press and release the button on the mouse. This is called “clicking on” an answer. The tutorial will give you practice using the mouse.



## HOW TO SCROLL

When the scroll bar appears next to a passage, you will use it to view reading passages that do not fit on the screen at one time. You will use the mouse to control the scroll bar. The scroll bar lets you move the passage up and down on the screen. The tutorial will give you practice scrolling.

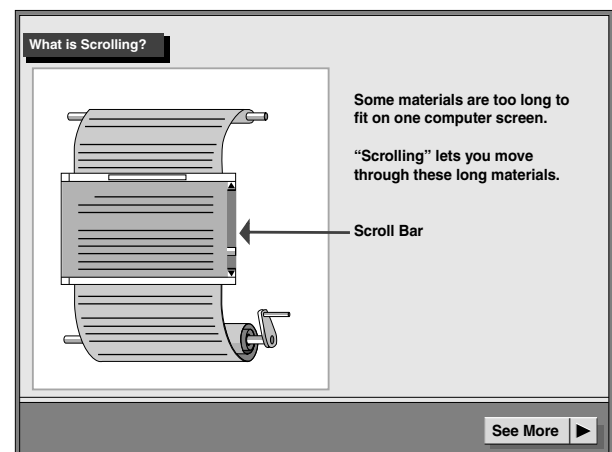

You will also see a gray bar at the top of the passage. This bar tells you where you are in the passage with the words “Beginning,” “More Available,” or “End.”

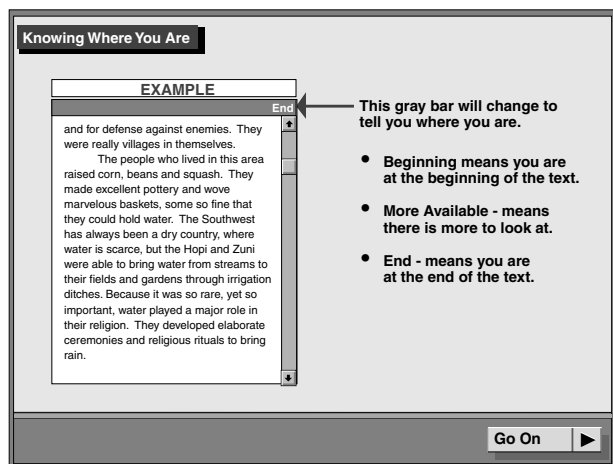

## TITLE BAR

At the top of the screen, you will see a bar. This is called the title bar. Along with the test section title, the title bar shows the time remaining in the test section, the current question number, and the total number of questions in the section.

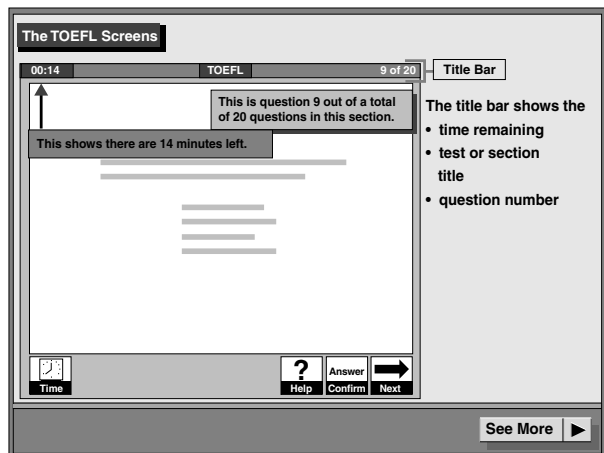

## HOW TO USE THE TESTING TOOLS

At the bottom of the screen, you will see some boxes with pictures or symbols in them (icons). These are called testing tools. Testing tools help you to move through the test and get information about the test. You can click on each of the icons with the mouse.

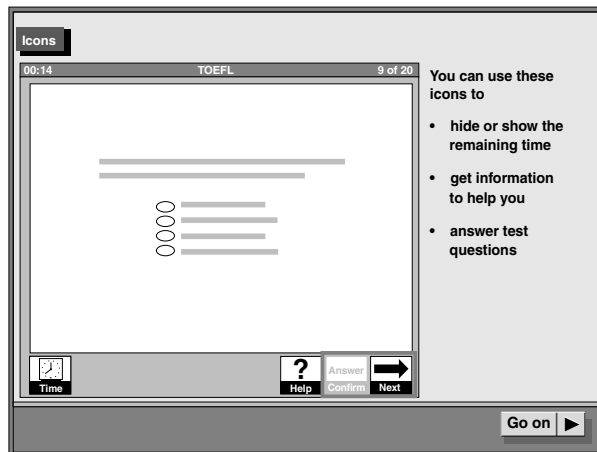

**Time**

You can click on **Time** to hide or show the time display on the title bar. The time display will flash briefly when five minutes of test time remain. The time display will stay on during the remainder of the section.



**Help**

You can click on **Help** to review directions and information from the tutorial. If you click on **Help** while the test is in progress, time will continue to run.



**Next**

Clicking on **Next** is the first of two steps to leave the question you are on and move to the next screen.



**Answer Confirm**

(in the Listening, Structure, and Writing sections) Clicking on **Confirm Answer** is the second step to leave the question you are on. When you click on **Confirm Answer** in the Listening and Structure sections, your answer is saved and a new question appears. In these sections, you cannot skip questions or go back to the questions you have already answered.

The Writing section contains only **one** topic. Therefore, clicking on **Next** and **Confirm Answer** will end the Writing section. You will not be able to return to the Writing section if you exit it.

**Note: You must answer at least one question in each section and compose an essay to receive an official score report.**



(in the Reading section) Clicking on **Prev** (**Previous**) will take you back to the previous questions within the Reading section. You can use **Prev** to go back to any question and review or change your answer. The Previous tool is only available in the Reading section.

## VOLUME CONTROL

In the Listening section of the test, you will listen to spoken language by using headphones. You will be able to adjust the volume by clicking on the up or down arrows. You will have the opportunity to adjust the volume during the test, but the time will not stop. Another volume control exists on the headphone wiring, adjustable without using the mouse.

**Changing the Volume**

**How to Change the Volume**

The voice that you hear now is at the same volume that you will hear during the test.

If you need to change the volume:

Click on this icon to make the volume louder.

Click on this icon to make the volume softer.

The next sentences that you hear will be repeated:  
You may now change the volume. When the volume is OK, go on.

**Go On**

## HOW TO ANSWER

### Listening, Structure, and Reading

The computer tutorials will give you practice answering questions before starting each section of the test. Here are some examples of the types of questions on the test.

For most of the questions, you will need to choose the best of four possible answers. To choose an answer, you will click on a choice. The oval next to the answer will darken.

**Types of Questions**

**EXAMPLE**

Directions: Click on the work or phrase that best completes the sentence.

Geysers have often been compared to volcanoes \_\_\_\_\_ they both emit hot liquids from below the Earth's surface.

due to  
 because  
 in spite of  
 regardless

Clicking on an answer darkens the oval.

**Read and Watch**

To answer some questions you will:

- Click on a choice.

**See More**

Some questions will have special directions. The special directions will appear in a box under the question. For example, sometimes you will need to click on two answers. The directions “Click on 2 answers” will appear under the question. This kind of question uses squares instead of ovals. When you click on a choice, an “X” will show inside the square.

**Questions with More than One Answer**

**EXAMPLE**

Which two cities are in the United States of America?

Click on 2 answers.

Chicago  
 Singapore  
 Helsinki  
 New York

**Read and Watch**

To Answer

Click on 2 choices.

To Change an Answer

- Click on the choice that you want to change.
- Click on a new choice.

Remember, you can change your choice anytime before you click **Confirm Answer**.

**Go on**

Sometimes you will need to match words with categories. In this type of question, the choices will appear above empty boxes.

**Matching/Ordering Questions**

**EXAMPLE**

What is the appropriate category for each word?

Click on a word. Then click on the box where it belongs.

large      circle      red

shape      color      size

**Read and Watch**

To Answer

Click on a word. Then click on the box where it belongs.

To Change an Answer

- Click on a new word.
- Click on the box where you want to put it.

Remember, you can change your choice anytime before you click **Confirm Answer**.

**See More**

To choose an answer, you will click on a choice and then click on the box where you want to put it.

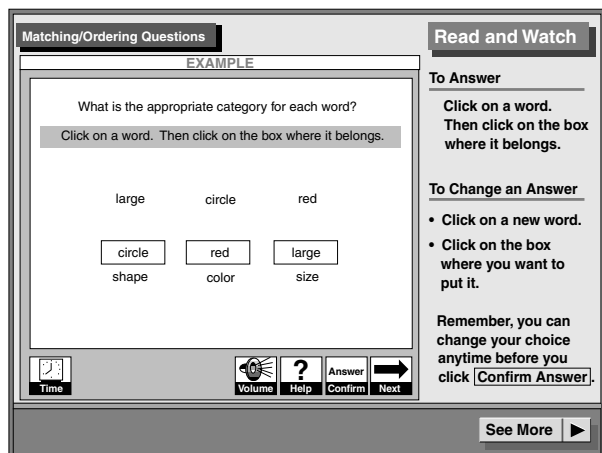

Sometimes you will need to find a certain word or phrase in a passage. To choose an answer, you will click on the word or phrase. Your choice will darken.

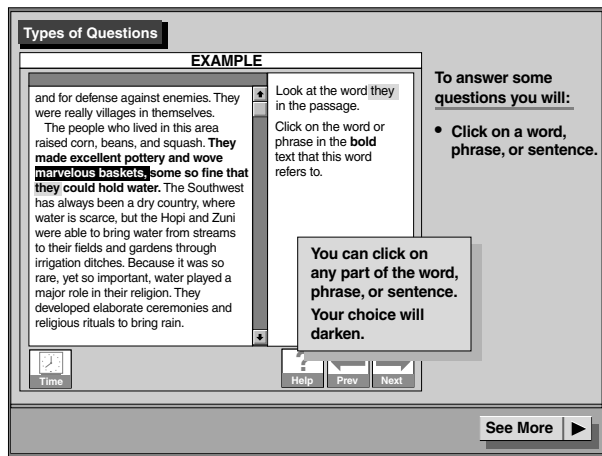

## HOW TO ANSWER

### Writing

You can either handwrite or type your essay. The writing tutorial will teach you how to type your essay on the computer. If you handwrite your essay, you do not need to complete this tutorial.

You should handwrite your essay if you are NOT comfortable

- typing
- composing written material on a keyboard
- using a keyboard with English characters

If you know you want to write your essay by hand, the tutorial will allow you to go directly to the writing test. You can do this by clicking on **Handwrite Essay Now** and confirming your choice. Otherwise, you will view the tutorial, and you will still have another opportunity to decide whether to handwrite or type your essay.

*The essay screen will look like this:*

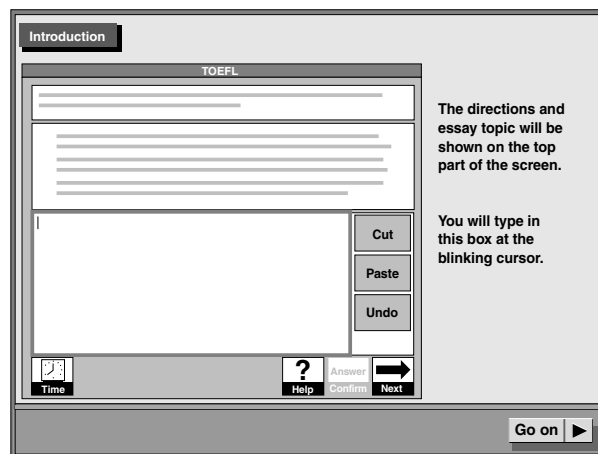

During the test, if you click on **Help** and then on **How to Answer** you will see the following screen, which gives you a summary of all the keys and actions you will need to type your essay.



## Sample Questions

This section of the *Bulletin* includes questions similar to those that will be presented in the actual test.

### LISTENING

The Listening section of the test measures the ability to understand conversations and talks in English. You will use headphones to listen to the conversations and talks. While you are listening, pictures of the speakers or other information will be presented on your computer screen. There are two parts to the Listening section, with special directions for each part.

On the day of the test, the amount of time you will have to answer all the questions will appear on the computer screen. The time you spend listening to the test material will not be counted. The listening material and questions about it will be presented only one time. You will not be allowed to take notes or have any paper at your computer. You will both see and hear the questions before the answer choices appear. You can take as much time as you need to select an answer; however, it will be to your advantage to answer the questions as quickly as possible. You may change your answer as many times as you want before you confirm it. After you have confirmed an answer, you will not be able to return to the question.

Before you begin working on the Listening section, you will have an opportunity to adjust the volume of the sound. You will only be able to change the volume during question directions, after you have started the test.

#### QUESTION DIRECTIONS — Part A

In Part A of the Listening section, you will hear short conversations between two people. In some of the conversations, each person speaks only once. In other conversations, one or both of the people speak more than once. Each conversation is followed by one question about it.

Each question in this part has four answer choices. You should click on the best answer to each question. Answer the questions on the basis of what is stated or implied by the speakers.

*Here is an example.*

**On the computer screen, you will see:**



**On the recording, you will hear:**

**(woman)** Hey, where's your sociology book?

**(man)** At home. Why carry it around when we're just going to be taking a test?

**(woman)** Don't you remember? Professor Smith said we could use it during the test.

**(man)** Oh, no! Well, I've still got an hour, right? I'm glad I ran into you!

**You will then see and hear the question before the answer choices appear:**

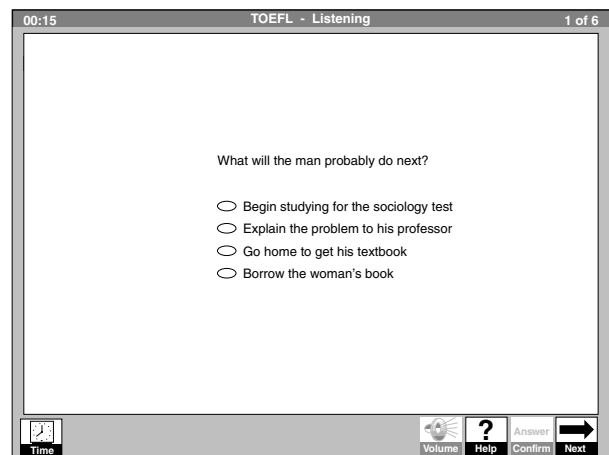

To choose an answer, you will click on an oval. The oval next to that answer will darken. **The correct answer is indicated on the next screen.**

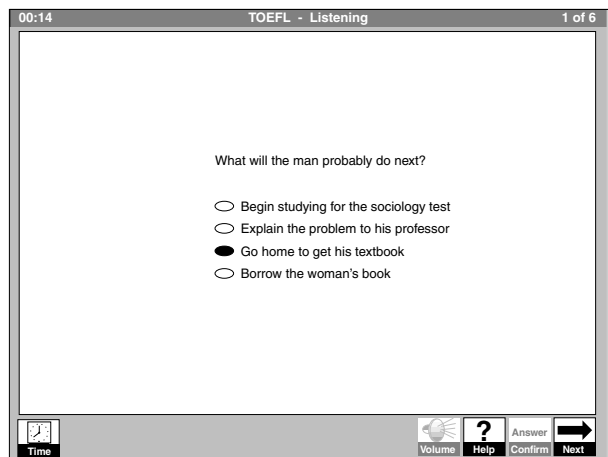

After you click on **Next** and **Confirm Answer**, the next conversation will be presented.

### QUESTION DIRECTIONS — Part B

In Part B of the Listening section, you will hear several longer conversations and talks. Each conversation or talk is followed by several questions. The conversations, talks, and questions will not be repeated.

The conversations and talks are about a variety of topics. You do not need special knowledge of the topics to answer the questions correctly. Rather, you should answer each question on the basis of what is stated or implied by the speakers in the conversations or talks.

For most of the questions, you will need to click on the best of four possible answers. Some questions will have special directions. The special directions will appear in a box on the computer screen.

*Here is an example of a conversation and some questions:*

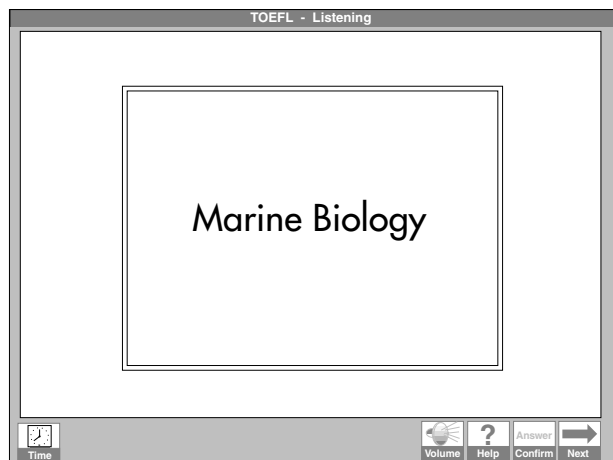

**(narrator)** Listen to part of a discussion in a marine biology class.

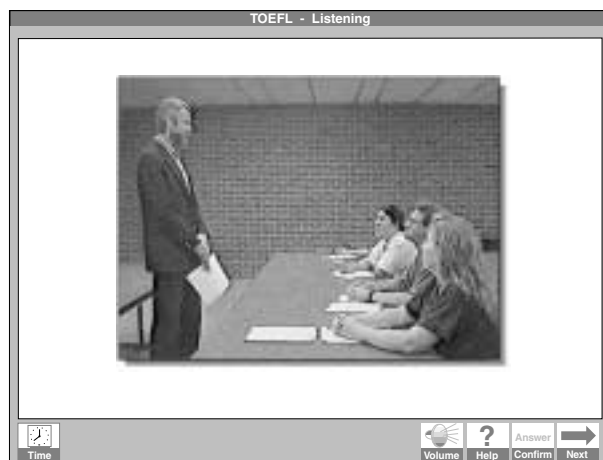

**(professor)** A few years ago, our local government passed a number of strict environmental laws. As a result, Sunrise Beach looks nothing like it did ten years ago. The water is cleaner, and there's been a tremendous increase in all kinds of marine life — which is why we're going there on Thursday.

**(woman)** I don't know if I agree that the water quality has improved. I mean, I was out there last weekend, and it looked all brown. It didn't seem too clean to me.

**(professor)** Actually, the color of the water doesn't always indicate whether it's polluted. The brown color you mentioned might be a result of pollution, or it can mean a kind of brown algae is growing there. It's called "devil's apron," and it actually serves as food for whales.

**(man)** So when does the water look blue?

**(professor)** Well, water that's completely unpolluted is actually colorless. But it often looks bluish-green because the sunlight can penetrate deep down and that's the color that's reflected.

**(woman)** But sometimes it looks really green. What's that about?

**(professor)** OK, well, it's the same principle as with "devil's apron": the water might look green because of different types of green algae there — gulfweed, phytoplankton. You all should finish reading about algae and plankton before we go. In fact, those are the types of living things I'm going to ask you to be looking for when we're there.

After the conversation, you will read:

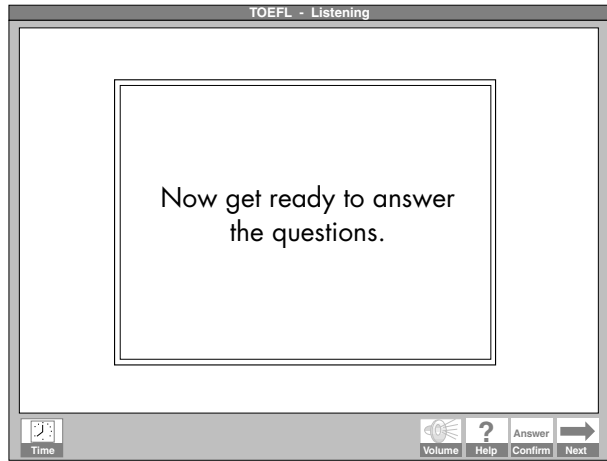

Then, the first question will be presented:

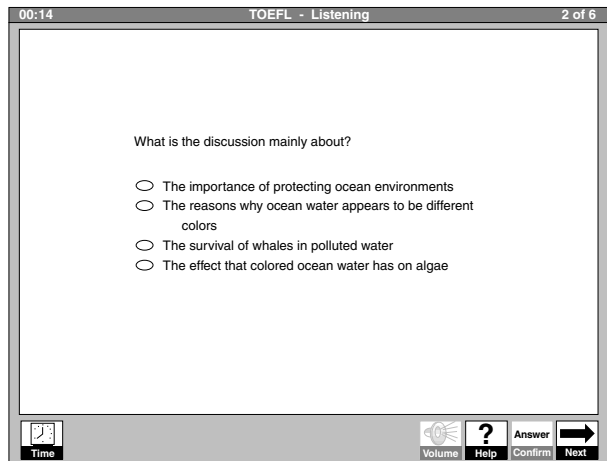

To choose an answer, you will click on an oval. The oval next to that answer will darken. The correct answer is indicated on the screen below.

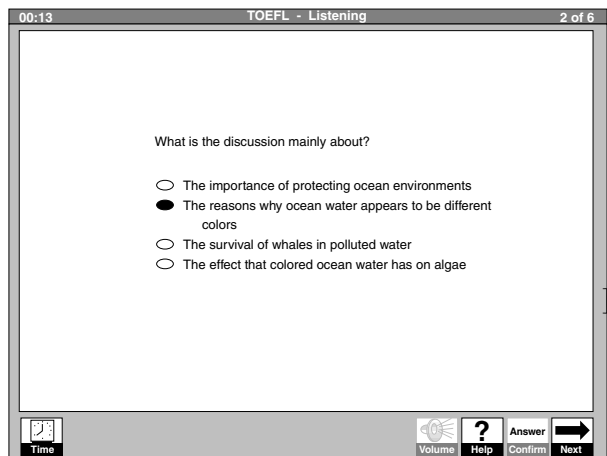

After you click on **Next** and **Confirm Answer**, the next question will be presented:

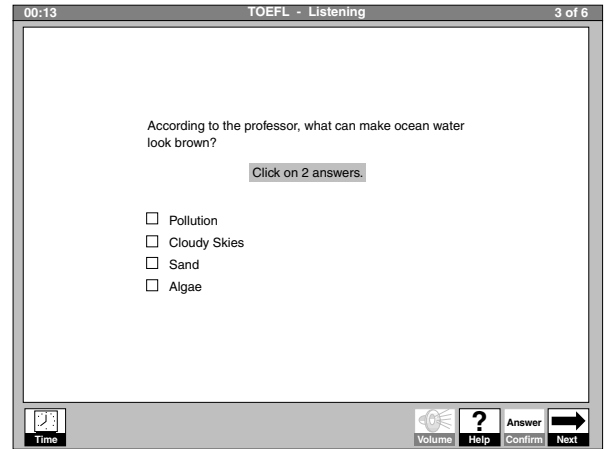

To choose your answers, you will click on the squares. An "X" will appear in each square. The correct answer is indicated on the screen below.

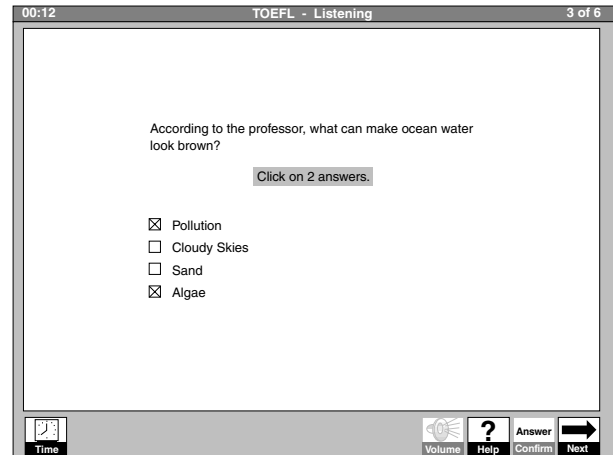

Sometimes the screen changes several times during a conversation or talk, as in the next example.

*Here is an example of a talk and some questions:*

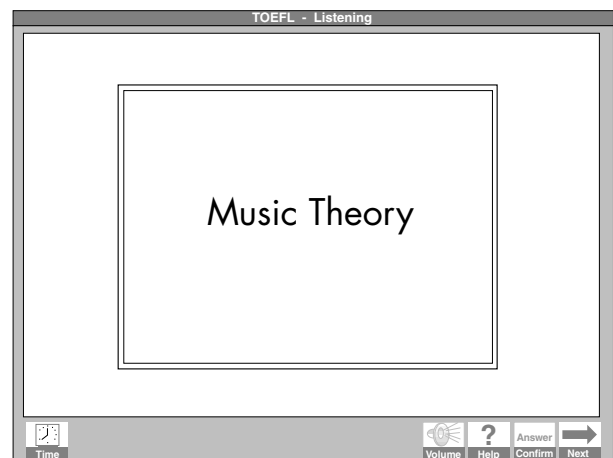

(narrator) Listen to part of a talk in a music theory class.



(professor) I'm sure if I asked you, you'd be able to tell me the common meaning of the word "interval."

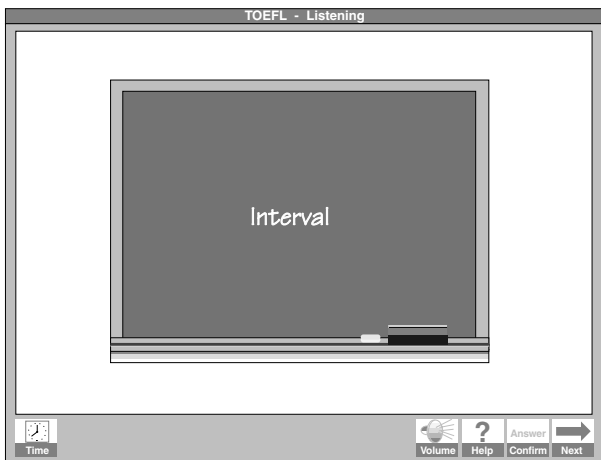

(professor) An interval is the period of time between two events. For example, buses might stop at a certain location every ten minutes — that is, at ten minute intervals. In the typical sense of the word, an interval is a period of time. But in music theory the word has a different meaning. A musical interval is the distance between two notes. So, if two notes are far apart, the musical interval between them is large. If two notes sound close together, the musical interval is small. The smallest musical interval is actually no distance at all between two notes. It's called "the unison," and that's the interval when two notes are exactly the same.



(professor) Today, I'd like to focus on a way of analyzing musical intervals by looking at the precise mathematical relationship that exists between musical notes. To do this, I've made some sounding boxes.

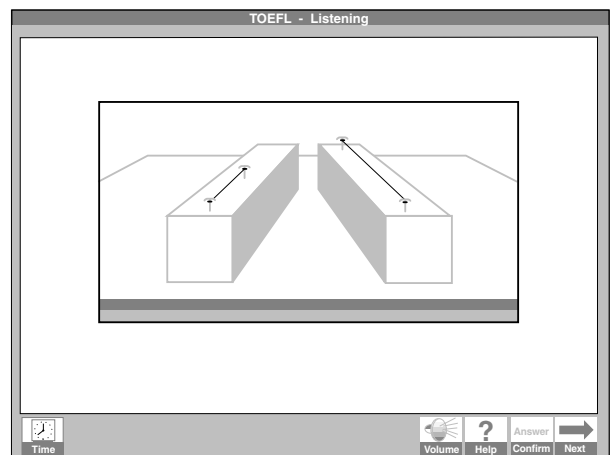

(professor) As you can see, they're just boxes made of wood with strings wrapped around two nails on the top. Now, the only difference between these two sounding boxes is the length of the string. I made the strings two different lengths to show you how this affects the sound. In fact, if you measured the length of the two strings, you'd see that the long string is exactly twice the length of the short string. So, the ratio between the short string and the long string is one to two. That's a pretty basic ratio, mathematically, and it produces an interval that is essential to many types of music — the octave.

After the talk, you will read:

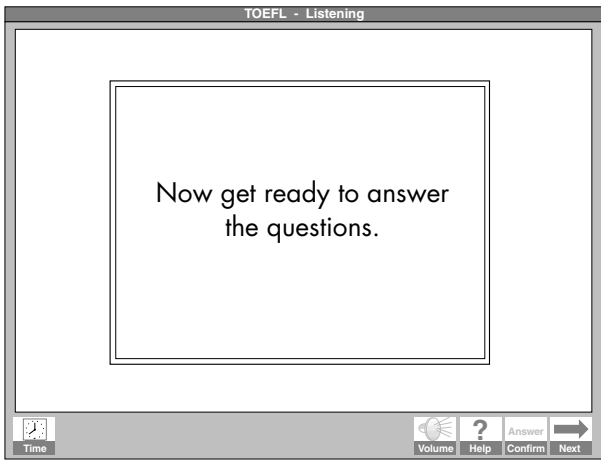

Then, the first question will be presented:

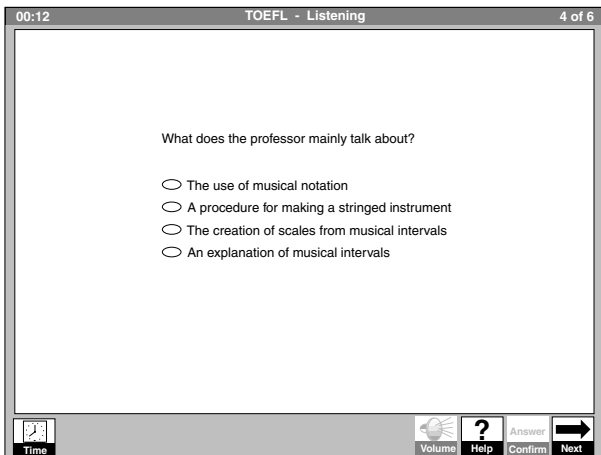

To choose an answer, you will click on an oval. The oval next to that answer will darken. The correct answer is indicated on the screen below.

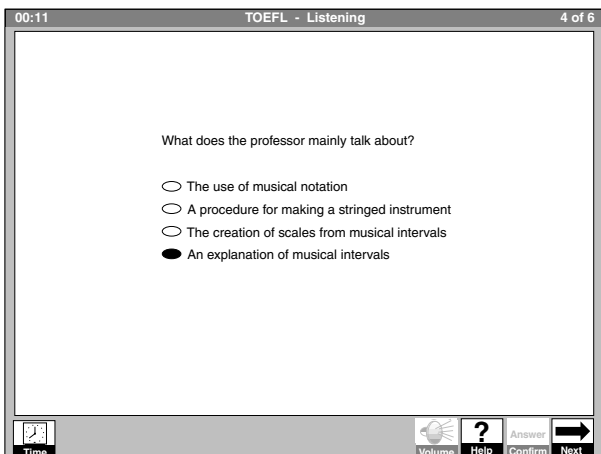

After you click on **Next** and **Confirm Answer**, the next question will be presented:

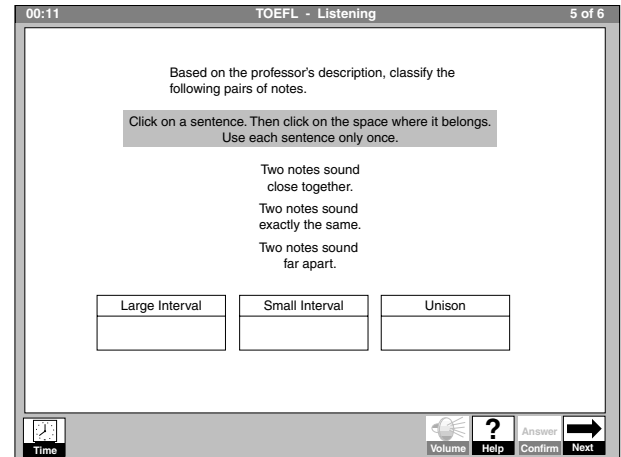

To choose your answers, you will click on a sentence and then click on the space where it belongs. As you do this, each sentence will appear in the square you have selected. The correct answer is indicated on the screen below.

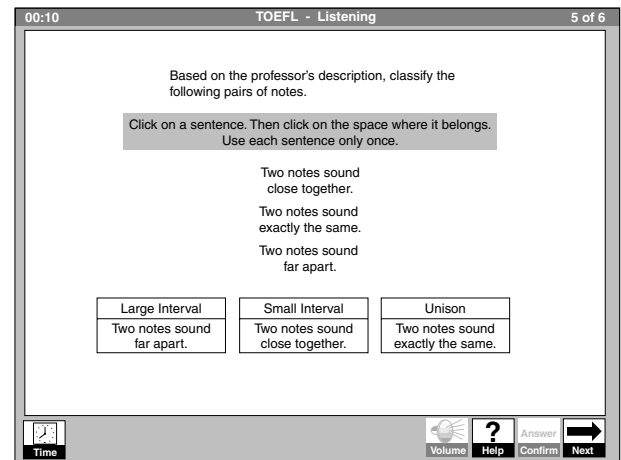

After you click on **Next** and **Confirm Answer**, the next question will be presented:

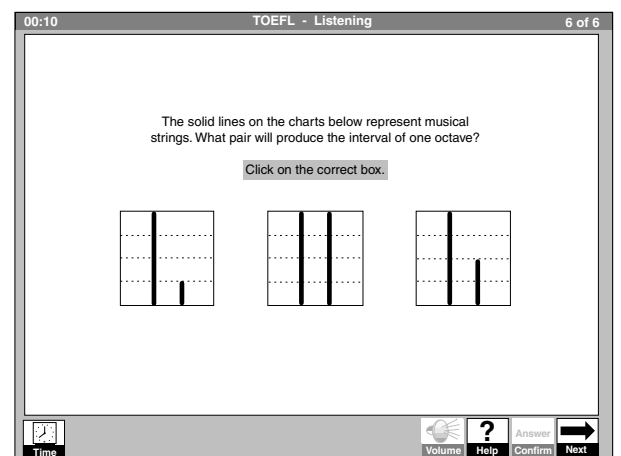

To choose your answer, you will click on the box. As you do this, the box will become highlighted. The correct answer is indicated on the screen below.

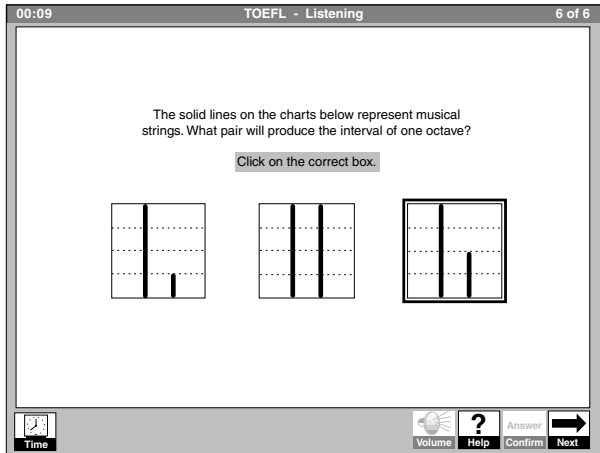

## STRUCTURE

This section measures the ability to recognize language that is appropriate for standard written English. There are two types of questions in this section.

In the first type of question, there are incomplete sentences. Beneath each sentence, there are four words or phrases. You will choose the one word or phrase that best completes the sentence.

*Here is an example:*

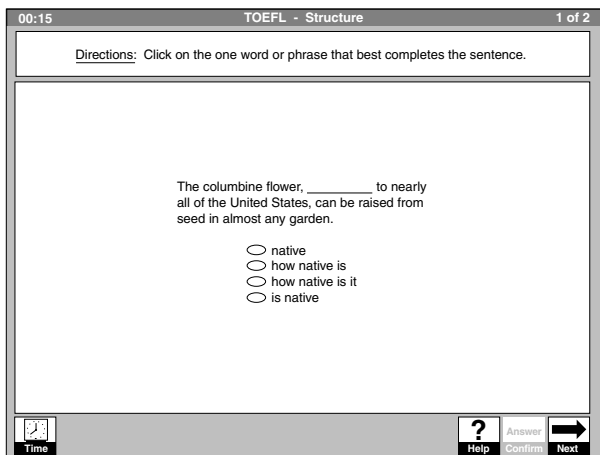

Clicking on a choice darkens the oval. The correct answer is indicated on the screen below.

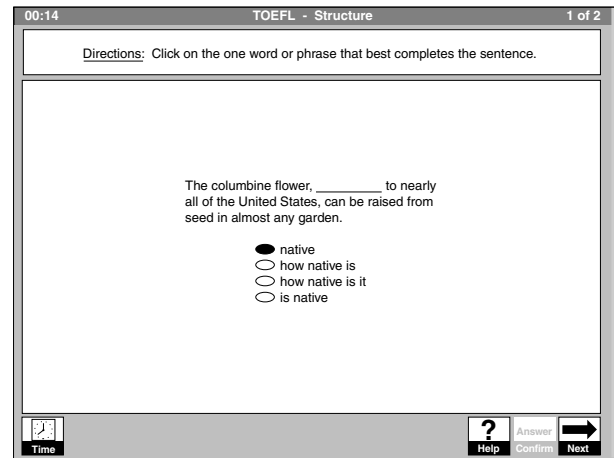

After you click on **Next** and **Confirm Answer**, the next question will be presented.

The second type of question has four underlined words or phrases. You will choose the one underlined word or phrase that must be changed for the sentence to be correct.

*Here is an example:*

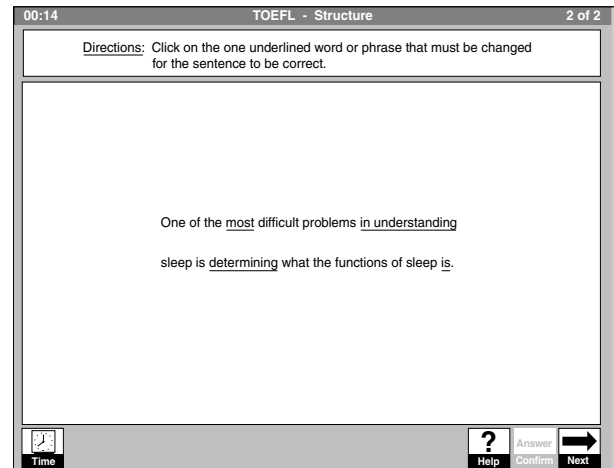

Clicking on an underlined word or phrase will darken it. The correct answer is indicated on the screen below.

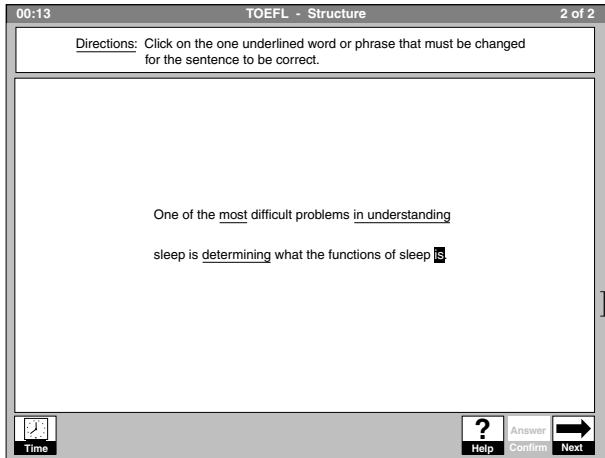

The sentence should read: One of the most difficult problems in understanding sleep is determining what the functions of sleep are. After you click on **Next** and **Confirm Answer**, the next question will be presented.

## READING

This section measures the ability to read and understand short passages similar in topic and style to those that students are likely to encounter in North American universities and colleges. This section contains reading passages and questions about the passages. There are several different types of questions in this section.

In the Reading section, you will first have the opportunity to read the passage.

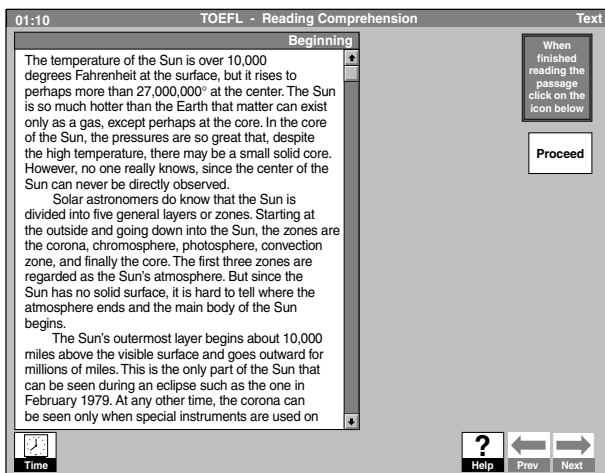

You will use the scroll bar to view the rest of the passage.

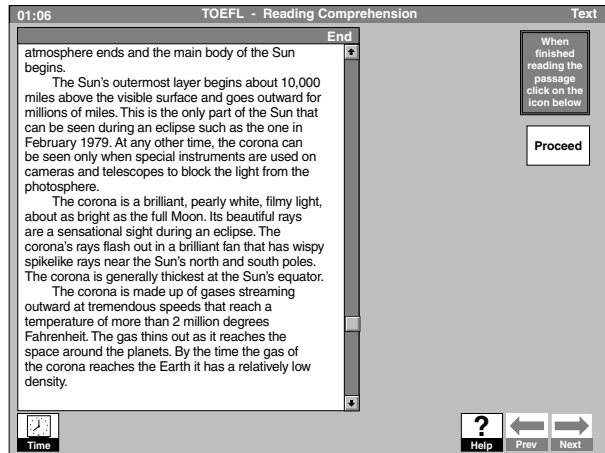

When you have finished reading the passage, you will use the mouse to click on **Proceed**. Then the questions about the passage will be presented. You are to choose the one best answer to each question. Answer all questions about the information in a passage on the basis of what is stated or implied in that passage.

Most of the questions will be multiple-choice questions. To answer these questions you will click on a choice below the question.

*Here is an example:*

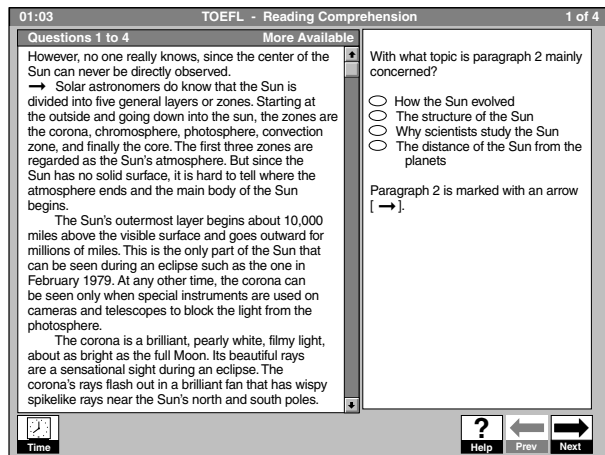

When you click on a choice, the oval darkens to show which answer you have chosen. To choose a different answer, click on a different oval.

The correct answer is indicated on the screen below.

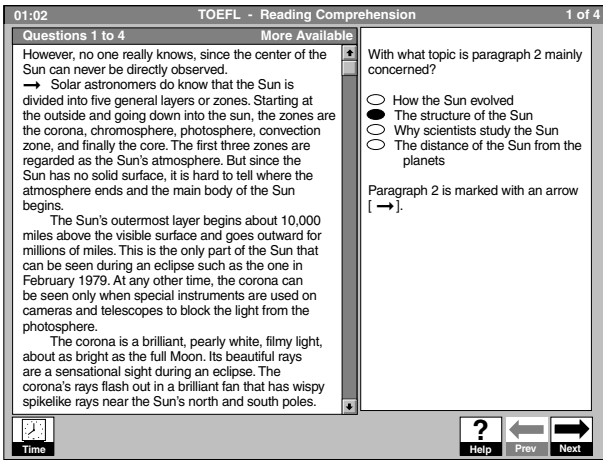

You will see the next question after you click on **Next**. To answer some questions you will click on a word or phrase.

*Here is an example:*

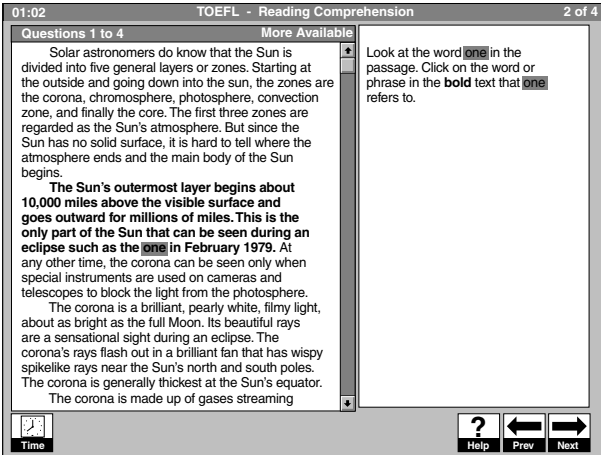

To answer, you can click on any part of the word or phrase in the passage. Your choice will darken to show which word you have chosen. The correct answer is indicated on the screen below.

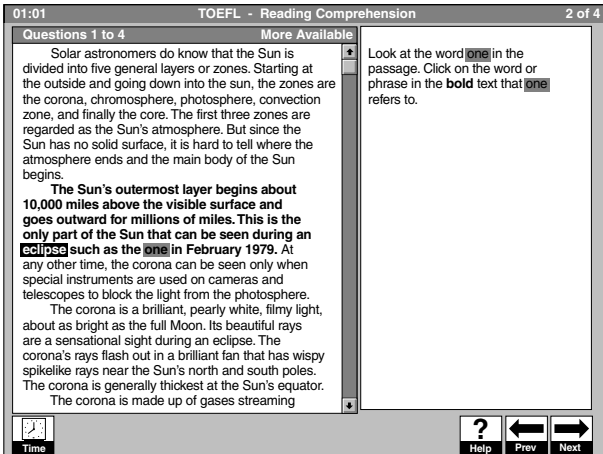

You will see the next question after you click on **Next**. To answer some questions you will click on a sentence in the passage.

*Here is an example:*

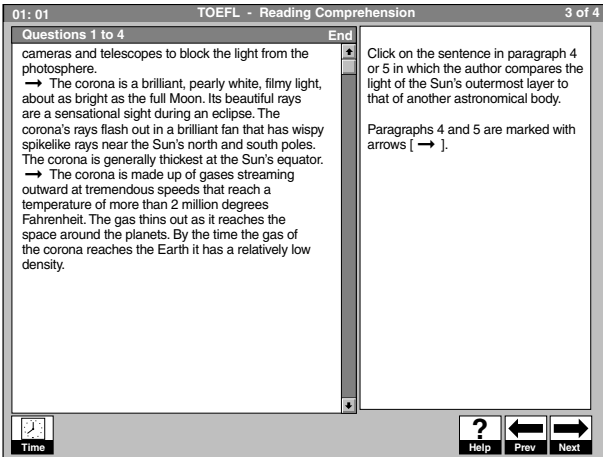

You can click on any part of the sentence in the passage. The sentence will darken to show which answer you have chosen. The correct answer is indicated below.

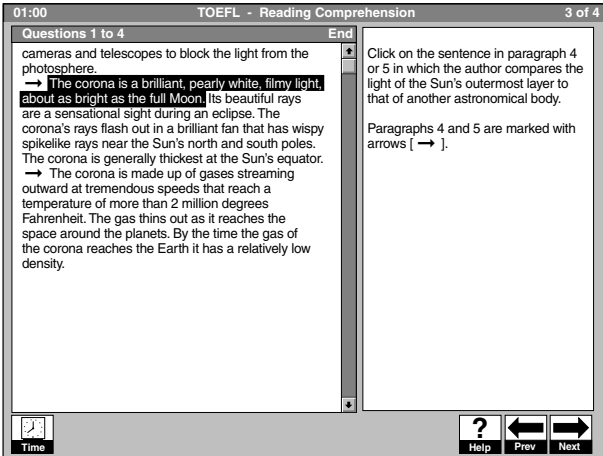

You will see the next question after you click on **Next**.

To answer some questions you will click on a square to add a sentence to the passage.

*Here is an example:*

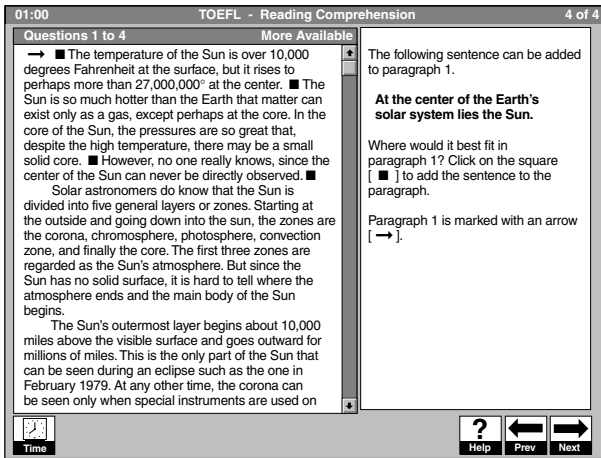

When you click on a square, the sentence will appear in the passage at the place you have chosen. You can read the sentence added to the paragraph to see if this is the best place to add it. You can click on another square to change your answer.

The sentence will be added and shown in a dark box. The correct answer is indicated on the screen below.

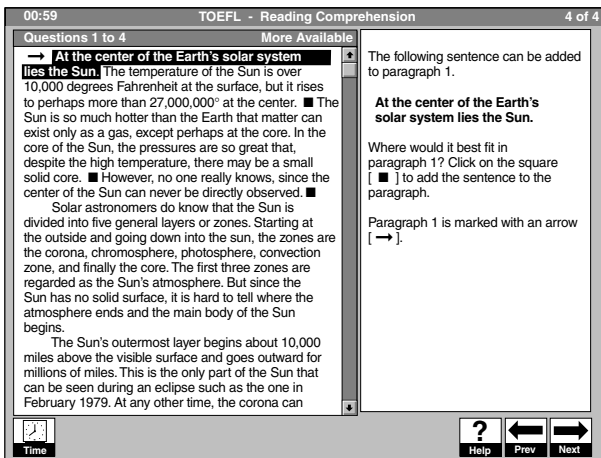

## WRITING

In this section, you will have an opportunity to demonstrate your ability to write in English. This includes the ability to generate and organize ideas, to support those ideas with examples or evidence, and to compose in standard written English in response to an assigned topic.

On the day of the test, an essay topic will be given to you. You will have 30 minutes to write your essay on that topic. You must write on the topic you are assigned. An essay on any other topic will receive a score of "0." Before the topic is presented, you must choose whether to type your essay on the computer or to handwrite your essay on the paper essay answer sheet provided.

Scratch paper will be given to you for making notes. However, only your response handwritten on the single page, two-sided essay answer sheet or typed in the essay box on the computer will be scored.

The essay topic will be presented to you on the computer screen. The essay screen will be similar to this:

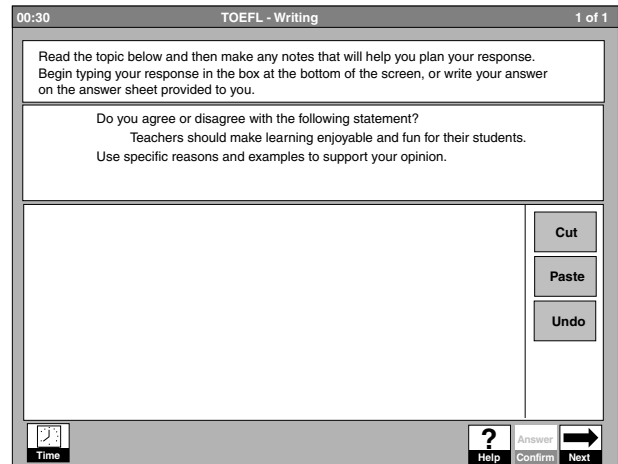

You can click on **Next** and **Confirm Answer** to end the Writing Section at any time. At the end of 30 minutes, the computer will automatically end the section.

# Writing Topics

Topics in the following list may appear in your actual test. You should become familiar with this list before you take the computer-based TOEFL test. Remember that when you take the test you will **not** have a choice of topics. You must write only on the topic that is assigned to you.

People attend college or university for many different reasons (for example, new experiences, career preparation, increased knowledge). Why do **you** think people attend college or university? Use specific reasons and examples to support your answer.

Do you agree or disagree with the following statement? Parents are the best teachers. Use specific reasons and examples to support your answer.

Nowadays, food has become easier to prepare. Has this change improved the way people live? Use specific reasons and examples to support your answer.

It has been said, "Not everything that is learned is contained in books." Compare and contrast knowledge gained from experience with knowledge gained from books. In your opinion, which source is more important? Why?

A company has announced that it wishes to build a large factory near your community. Discuss the advantages and disadvantages of this new influence on your community. Do you support or oppose the factory? Explain your position.

If you could change one important thing about your hometown, what would you change? Use reasons and specific examples to support your answer.

How do movies or television influence people's behavior? Use reasons and specific examples to support your answer.

Do you agree or disagree with the following statement? Television has destroyed communication among friends and family. Use specific reasons and examples to support your opinion.

Some people prefer to live in a small town. Others prefer to live in a big city. Which place would you prefer to live in? Use specific reasons and details to support your answer.

"When people succeed, it is because of hard work. Luck has nothing to do with success." Do you agree or disagree with the quotation above? Use specific reasons and examples to explain your position.

Do you agree or disagree with the following statement? Universities should give the same amount of money to their students' sports activities as they give to their university libraries. Use specific reasons and examples to support your opinion.

Many people visit museums when they travel to new places. Why do you think people visit museums? Use specific reasons and examples to support your answer.

Some people prefer to eat at food stands or restaurants. Other people prefer to prepare and eat food at home. Which do you prefer? Use specific reasons and examples to support your answer.

Some people believe that university students should be required to attend classes. Others believe that going to classes should be optional for students. Which point of view do you agree with? Use specific reasons and details to explain your answer.

Neighbors are the people who live near us. In your opinion, what are the qualities of a good neighbor? Use specific details and examples in your answer.

It has recently been announced that a new restaurant may be built in your neighborhood. Do you support or oppose this plan? Why? Use specific reasons and details to support your answer.

Some people think that they can learn better by themselves than with a teacher. Others think that it is always better to have a teacher. Which do you prefer? Use specific reasons to develop your essay.

What are some important qualities of a good supervisor (boss)? Use specific details and examples to explain why these qualities are important.

Should governments spend more money on improving roads and highways, or should governments spend more money on improving public transportation (buses, trains, subways)? Why? Use specific reasons and details to develop your essay.

It is better for children to grow up in the countryside than in a big city. Do you agree or disagree? Use specific reasons and examples to develop your essay.

In general, people are living longer now. Discuss the causes of this phenomenon. Use specific reasons and details to develop your essay.

We all work or will work in our jobs with many different kinds of people. In your opinion, what are some important characteristics of a co-worker (someone you work closely with)? Use reasons and specific examples to explain why these characteristics are important.

In some countries, teenagers have jobs while they are still students. Do you think this is a good idea? Support your opinion by using specific reasons and details.

A person you know is planning to move to your town or city. What do you think this person would like and dislike about living in your town or city? Why? Use specific reasons and details to develop your essay.

It has recently been announced that a large shopping center may be built in your neighborhood. Do you support or oppose this plan? Why? Use specific reasons and details to support your answer.

It has recently been announced that a new movie theater may be built in your neighborhood. Do you support or oppose this plan? Why? Use specific reasons and details to support your answer.

Do you agree or disagree with the following statement? People should sometimes do things that they do **not** enjoy doing. Use specific reasons and examples to support your answer.

Do you agree or disagree with the following statement? Television, newspapers, magazines, and other media pay too much attention to the personal lives of famous people such as public figures and celebrities. Use specific reasons and details to explain your opinion.

Some people believe that the Earth is being harmed (damaged) by human activity. Others feel that human activity makes the Earth a better place to live. What is your opinion? Use specific reasons and examples to support your answer.

It has recently been announced that a new high school may be built in your community. Do you support or oppose this plan? Why? Use specific reasons and details in your answer.

## Writing Topics (continued)

Some people spend their entire lives in one place. Others move a number of times throughout their lives, looking for a better job, house, community, or even climate. Which do you prefer: staying in one place or moving in search of another place? Use reasons and specific examples to support your opinion.

Is it better to enjoy your money when you earn it or is it better to save your money for some time in the future? Use specific reasons and examples to support your opinion.

You have received a gift of money. The money is enough to buy either a piece of jewelry you like or tickets to a concert you want to attend. Which would you buy? Use specific reasons and details to support your answer.

Businesses should hire employees for their entire lives. Do you agree or disagree? Use specific reasons and examples to support your answer.

Do you agree or disagree with the following statement? Attending a live performance (for example, a play, concert, or sporting event) is more enjoyable than watching the same event on television. Use specific reasons and examples to support your opinion.

Choose **one** of the following transportation vehicles and explain why you think it has changed people's lives.

- automobiles
- bicycles
- airplanes

Use specific reasons and examples to support your answer.

Do you agree or disagree that progress is always good? Use specific reasons and examples to support your answer.

Learning about the past has no value for those of us living in the present. Do you agree or disagree? Use specific reasons and examples to support your answer.

Do you agree or disagree with the following statement? With the help of technology, students nowadays can learn more information and learn it more quickly. Use specific reasons and examples to support your answer.

The expression "Never, never give up" means to keep trying and never stop working for your goals. Do you agree or disagree with this statement? Use specific reasons and examples to support your answer.

Some people think that human needs for farmland, housing, and industry are more important than saving land for endangered animals. Do you agree or disagree with this point of view? Why or why not? Use specific reasons and examples to support your answer.

What is a very important skill a person should learn in order to be successful in the world today? Choose **one** skill and use specific reasons and examples to support your choice.

Why do you think some people are attracted to dangerous sports or other dangerous activities? Use specific reasons and examples to support your answer.

Some people like to travel with a companion. Other people prefer to travel alone. Which do you prefer? Use specific reasons and examples to support your choice.

Some people prefer to get up early in the morning and start the day's work. Others prefer to get up later in the day and work until late at night. Which do you prefer? Use specific reasons and examples to support your choice.

What are the important qualities of a good son or daughter? Have these qualities changed or remained the same over time in your culture? Use specific reasons and examples to support your answer.

Some people prefer to work for a large company. Others prefer to work for a small company. Which would you prefer? Use specific reasons and details to support your choice.

People work because they need money to live. What are some **other** reasons that people work? Discuss one or more of these reasons. Use specific examples and details to support your answer.

Do you agree or disagree with the following statement? Face-to-face communication is better than other types of communication, such as letters, email, or telephone calls. Use specific reasons and details to support your answer.

Some people like to do only what they already do well. Other people prefer to try new things and take risks. Which do you prefer? Use specific reasons and examples to support your choice.

Some people believe that success in life comes from taking risks or chances. Others believe that success results from careful planning. In your opinion, what does success come from? Use specific reasons and examples to support your answer.

What change would make your hometown more appealing to people your age? Use specific reasons and examples to support your opinion.

Do you agree or disagree with the following statement? The most important aspect of a job is the money a person earns. Use specific reasons and examples to support your answer.

Do you agree or disagree with the following statement? One should never judge a person by external appearances. Use specific reasons and details to support your answer.

Do you agree or disagree with the following statement? A person should never make an important decision alone. Use specific reasons and examples to support your answer.

A company is going to give some money either to support the arts or to protect the environment. Which do you think the company should choose? Use specific reasons and examples to support your answer.

Some movies are serious, designed to make the audience think. Other movies are designed primarily to amuse and entertain. Which type of movie do you prefer? Use specific reasons and examples to support your answer.

Do you agree or disagree with the following statement? Businesses should do anything they can to make a profit. Use specific reasons and examples to support your position.

Some people are always in a hurry to go places and get things done. Other people prefer to take their time and live life at a slower pace. Which do you prefer? Use specific reasons and examples to support your answer.

Do you agree or disagree with the following statement? Games are as important for adults as they are for children. Use specific reasons and examples to support your answer.

Do you agree or disagree with the following statement? Parents or other adult relatives should make important decisions for their older (15 to 18 year-old) teenage children. Use specific reasons and examples to support your opinion.

What do you want **most** in a friend — someone who is intelligent, or someone who has a sense of humor, or someone who is reliable? Which **one** of these characteristics is most important to you? Use reasons and specific examples to explain your choice.

Do you agree or disagree with the following statement? Most experiences in our lives that seemed difficult at the time become valuable lessons for the future. Use reasons and specific examples to support our answer.

Some people prefer to work for themselves or own a business. Others prefer to work for an employer. Would you rather be self-employed, work for someone else, or own a business? Use specific reasons to explain your choice.

Should a city try to preserve its old, historic buildings or destroy them and replace them with modern buildings? Use specific reasons and examples to support your opinion.

Do you agree or disagree with the following statement? Classmates are a more important influence than parents on a child's success in school. Use specific reasons and examples to support your answer.

If you were an employer, which kind of worker would you prefer to hire: an inexperienced worker at a lower salary or an experienced worker at a higher salary? Use specific reasons and details to support your answer.

Many teachers assign homework to students every day. Do you think that daily homework is necessary for students? Use specific reasons and details to support your answer.

If you could study a subject that you have never had the opportunity to study, what would you choose? Explain your choice, using specific reasons and details.

Some people think that the automobile has improved modern life. Others think that the automobile has caused serious problems. What is your opinion? Use specific reasons and examples to support your answer.

Which would you choose: a high-paying job with long hours that would give you little time with family and friends or a lower-paying job with shorter hours that would give you more time with family and friends? Explain your choice, using specific reasons and details.

Do you agree or disagree with the following statement? Grades (marks) encourage students to learn. Use specific reasons and examples to support your opinion.

Some people say that computers have made life easier and more convenient. Other people say that computers have made life more complex and stressful. What is your opinion? Use specific reasons and examples to support your answer.

Do you agree or disagree with the following statement? The best way to travel is in a group led by a tour guide. Use specific reasons and examples to support your answer.

Some universities require students to take classes in many subjects. Other universities require students to specialize in one subject. Which is better? Use specific reasons and examples to support your answer.

Do you agree or disagree with the following statement? Children should begin learning a foreign language as soon as they start school. Use specific reasons and examples to support your position.

Do you agree or disagree with the following statement? Boys and girls should attend separate schools. Use specific reasons and examples to support your answer.

Is it more important to be able to work with a group of people on a team or to work independently? Use reasons and specific examples to support your answer.

Your city has decided to build a statue or monument to honor a famous person in your country. Who would you choose? Use reasons and specific examples to support your choice.

Describe a custom from your country that you would like people from other countries to adopt. Explain your choice, using specific reasons and examples.

Do you agree or disagree with the following statement? Technology has made the world a better place to live. Use specific reasons and examples to support your opinion.

Do you agree or disagree with the following statement? Advertising can tell you a lot about a country. Use specific reasons and examples to support your answer.

Do you agree or disagree with the following statement? Modern technology is creating a single world culture. Use specific reasons and examples to support your opinion.

Some people say that the Internet provides people with a lot of valuable information. Others think access to so much information creates problems. Which view do you agree with? Use specific reasons and examples to support your opinion.

A foreign visitor has only one day to spend in your country. Where should this visitor go on that day? Why? Use specific reasons and details to support your choice.

If you could go back to some time and place in the past, when and where would you go? Why? Use specific reasons and details to support your choice.

What discovery in the last 100 years has been most beneficial for people in your country? Use specific reasons and examples to support your choice.

Do you agree or disagree with the following statement? Telephones and email have made communication between people less personal. Use specific reasons and examples to support your opinion.

If you could travel back in time to meet a famous person from history, what person would you like to meet? Use specific reasons and examples to support your choice.

If you could meet a famous entertainer or athlete, who would that be, and why? Use specific reasons and examples to support your choice.

If you could ask a famous person **one** question, what would you ask? Why? Use specific reasons and details to support your answer.

Some people prefer to live in places that have the same weather or climate all year long. Others like to live in areas where the weather changes several times a year. Which do you prefer? Use specific reasons and examples to support your choice.

Many students have to live with roommates while going to school or university. What are some of the important qualities of a good roommate? Use specific reasons and examples to explain why these qualities are important.

Do you agree or disagree with the following statement? Dancing plays an important role in a culture. Use specific reasons and examples to support your answer.

Some people think governments should spend as much money as possible exploring outer space (for example, traveling to the Moon and to other planets). Other people disagree and think governments should spend this money for our basic needs on Earth. Which of these two opinions do you agree with? Use specific reasons and details to support your answer.

People have different ways of escaping the stress and difficulties of modern life. Some read; some exercise; others work in their gardens. What do you think are the best ways of reducing stress? Use specific details and examples in your answer.

Do you agree or disagree with the following statement? Teachers should be paid according to how much their students learn. Give specific reasons and examples to support your opinion.

If you were asked to send one thing representing your country to an international exhibition, what would you choose? Why? Use specific reasons and details to explain your choice.

You have been told that dormitory rooms at your university must be shared by two students. Would you rather have the university assign a student to share a room with you, or would you rather choose your own roommate? Use specific reasons and details to explain your answer.

## Writing Topics (continued)

Some people think that governments should spend as much money as possible on developing or buying computer technology. Other people disagree and think that this money should be spent on more basic needs. Which one of these opinions do you agree with? Use specific reasons and details to support your answer.

Some people like doing work by hand. Others prefer using machines. Which do you prefer? Use specific reasons and examples to support your answer.

Schools should ask students to evaluate their teachers. Do you agree or disagree? Use specific reasons and examples to support your answer.

In your opinion, what is the most important characteristic (for example, honesty, intelligence, a sense of humor) that a person can have to be successful in life? Use specific reasons and examples from your experience to explain your answer. When you write your answer, you are not limited to the examples listed in the question.

It is generally agreed that society benefits from the work of its members. Compare the contributions of artists to society with the contributions of scientists to society. Which type of contribution do you think is valued more by your society? Give specific reasons to support your answer.

Students at universities often have a choice of places to live. They may choose to live in university dormitories, or they may choose to live in apartments in the community. Compare the advantages of living in university housing with the advantages of living in an apartment in the community. Where would you prefer to live? Give reasons for your preference.

You need to travel from your home to a place 40 miles (64 kilometers) away. Compare the different kinds of transportation you could use. Tell which method of travel you would choose. Give specific reasons for your choice.

Some people believe that a college or university education should be available to all students. Others believe that higher education should be available only to good students. Discuss these views. Which view do you agree with? Explain why.

Some people believe that the best way of learning about life is by listening to the advice of family and friends. Other people believe that the best way of learning about life is through personal experience. Compare the advantages of these two different ways of learning about life. Which do you think is preferable? Use specific examples to support your preference.

When people move to another country, some of them decide to follow the customs of the new country. Others prefer to keep their own customs. Compare these two choices. Which one do you prefer? Support your answer with specific details.

Some people prefer to spend most of their time alone. Others like to be with friends most of the time. Do you prefer to spend your time alone or with friends? Use specific reasons to support your answer.

Some people prefer to spend time with one or two close friends. Others choose to spend time with a large number of friends. Compare the advantages of each choice. Which of these two ways of spending time do you prefer? Use specific reasons to support your answer.

Some people think that children should begin their formal education at a very early age and should spend most of their time on school studies. Others believe that young children should spend most of their time playing. Compare these two views. Which view do you agree with? Why?

The government has announced that it plans to build a new university. Some people think that **your** community would be a good place to locate the university. Compare the advantages and disadvantages of establishing a new university in your community. Use specific details in your discussion.

Some people think that the family is the most important influence on young adults. Other people think that friends are the most important influence on young adults. Which view do you agree with? Use examples to support your position.

Some people prefer to plan activities for their free time very carefully. Others choose not to make any plans at all for their free time. Compare the benefits of planning free-time activities with the benefits of not making plans. Which do you prefer — planning or not planning for your leisure time? Use specific reasons and examples to explain your choice.

People learn in different ways. Some people learn by doing things; other people learn by reading about things; others learn by listening to people talk about things. Which of these methods of learning is best for you? Use specific examples to support your choice.

Some people choose friends who are different from themselves. Others choose friends who are similar to themselves. Compare the advantages of having friends who are different from you with the advantages of having friends who are similar to you. Which kind of friend do you prefer for yourself? Why?

Some people enjoy change, and they look forward to new experiences. Others like their lives to stay the same, and they do not change their usual habits. Compare these two approaches to life. Which approach do you prefer? Explain why.

Do you agree or disagree with the following statement? People behave differently when they wear different clothes. Do you agree that different clothes influence the way people behave? Use specific examples to support your answer.

Decisions can be made quickly, or they can be made after careful thought. Do you agree or disagree with the following statement? The decisions that people make quickly are always wrong. Use reasons and specific examples to support your opinion.

Some people trust their first impressions about a person's character because they believe these judgments are generally correct. Other people do not judge a person's character quickly because they believe first impressions are often wrong. Compare these two attitudes. Which attitude do you agree with? Support your choice with specific examples.

Do you agree or disagree with the following statement? People are never satisfied with what they have; they always want something more or something different. Use specific reasons to support your answer.

Do you agree or disagree with the following statement? People should read **only** those books that are about real events, real people, and established facts. Use specific reasons and details to support your opinion.

Do you agree or disagree with the following statement? It is more important for students to study history and literature than it is for them to study science and mathematics. Use specific reasons and examples to support your opinion.

Do you agree or disagree with the following statement? All students should be required to study art and music in secondary school. Use specific reasons to support your answer.

Do you agree or disagree with the following statement? There is nothing that young people can teach older people. Use specific reasons and examples to support your position.

Do you agree or disagree with the following statement? Reading fiction (such as novels and short stories) is more enjoyable than watching movies. Use specific reasons and examples to explain your position.

Some people say that physical exercise should be a required part of every school day. Other people believe that students should spend the whole school day on academic studies. Which opinion do you agree with? Use specific reasons and details to support your answer.

A university plans to develop a new research center in your country. Some people want a center for business research. Other people want a center for research in agriculture (farming). Which of these two kinds of research centers do you recommend for your country? Use specific reasons in your recommendation.

Some young children spend a great amount of their time practicing sports. Discuss the advantages and disadvantages of this. Use specific reasons and examples to support your answer.

Do you agree or disagree with the following statement? **Only** people who earn a lot of money are successful. Use specific reasons and examples to support your answer.

If you could invent something **new**, what product would you develop? Use specific details to explain why this invention is needed.

Do you agree or disagree with the following statement? A person's childhood years (the time from birth to twelve years of age) are the most important years of a person's life. Use specific reasons and examples to support your answer.

Do you agree or disagree with the following statement? Children should be required to help with household tasks as soon as they are able to do so. Use specific reasons and examples to support your answer.

Some high schools require all students to wear school uniforms. Other high schools permit students to decide what to wear to school. Which of these two school policies do you think is better? Use specific reasons and examples to support your opinion.

Do you agree or disagree with the following statement? Playing a game is fun only when you win. Use specific reasons and examples to support your answer.

Do you agree or disagree with the following statement? High schools should allow students to study the courses that students want to study. Use specific reasons and examples to support your opinion.

Do you agree or disagree with the following statement? It is better to be a member of a group than to be the leader of a group. Use specific reasons and examples to support your answer.

What do you consider to be the most important room in a house? Why is this room more important to you than any other room? Use specific reasons and examples to support your opinion.

Some items (such as clothes or furniture) can be made by hand or by machine. Which do you prefer — items made by hand or items made by machine? Use reasons and specific examples to explain your choice.

If you could make one important change in a school that you attended, what change would you make? Use reasons and specific examples to support your answer.

A gift (such as a camera, a soccer ball, or an animal) can contribute to a child's development. What gift would you give to help a child develop? Why? Use reasons and specific examples to support your choice.

Some people believe that students should be given one long vacation each year. Others believe that students should have several short vacations throughout the year. Which viewpoint do you agree with? Use specific reasons and examples to support your choice.

Would you prefer to live in a traditional house or in a modern apartment building? Use specific reasons and details to support your choice.

Some people say that advertising encourages us to buy things we really do not need. Others say that advertisements tell us about new products that may improve our lives. Which viewpoint do you agree with? Use specific reasons and examples to support your answer.

Some people prefer to spend their free time outdoors. Other people prefer to spend their leisure time indoors. Would you prefer to be outside or would you prefer to be inside for your leisure activities? Use specific reasons and examples to explain your choice.

Your school has received a gift of money. What do you think is the best way for your school to spend this money? Use specific reasons and details to support your choice.

Do you agree or disagree with the following statement? Playing games teaches us about life. Use specific reasons and examples to support your answer.

Imagine that you have received some land to use as you wish. How would you use this land? Use specific details to explain your answer.

Do you agree or disagree with the following statement? Watching television is bad for children. Use specific details and examples to support your answer.

What is the most important animal in your country? Why is the animal important? Use reasons and specific details to explain your answer.

Many parts of the world are losing important natural resources, such as forests, animals, or clean water. Choose **one** resource that is disappearing and explain why it needs to be saved. Use specific reasons and examples to support your opinion.

Do you agree or disagree with the following statement? A zoo has no useful purpose. Use specific reasons and examples to explain your answer.

In some countries, people are no longer allowed to smoke in many public places and office buildings. Do you think this is a good rule or a bad rule? Use specific reasons and details to support your position.

Plants can provide food, shelter, clothing, or medicine. What is one kind of plant that is important to you or the people in your country? Use specific reasons and details to explain your choice.

You have the opportunity to visit a foreign country for two weeks. Which country would you like to visit? Use specific reasons and details to explain your choice.

In the future, students may have the choice of studying at home by using technology such as computers or television or of studying at traditional schools. Which would you prefer? Use reasons and specific details to explain your choice.

When famous people such as actors, athletes and rock stars give their opinions, many people listen. Do you think we should pay attention to these opinions? Use specific reasons and examples to support your answer.

The twentieth century saw great change. In your opinion, what is **one** change that should be remembered about the twentieth century? Use specific reasons and details to explain your choice.

When people need to complain about a product or poor service, some prefer to complain in writing and others prefer to complain in person. Which way do you prefer? Use specific reasons and examples to support your answer.

People remember special gifts or presents that they have received. Why? Use specific reasons and examples to support your answer.

Some famous athletes and entertainers earn millions of dollars every year. Do you think these people deserve such high salaries? Use specific reasons and examples to support your opinion.

## Writing Topics (continued)

Is the ability to read and write more important today than in the past? Why or why not? Use specific reasons and examples to support your answer.

People do many different things to stay healthy. What do you do for good health? Use specific reasons and examples to support your answer.

You have decided to give several hours of your time each month to improve the community where you live. What is one thing you will do to improve your community? Why? Use specific reasons and details to explain your choice.

People recognize a difference between children and adults. What events (experiences or ceremonies) make a person an adult? Use specific reasons and examples to explain your answer.

Your school has enough money to purchase either computers for students or books for the library. Which should your school choose to buy — computers or books? Use specific reasons and examples to support your recommendation.

Many students choose to attend schools or universities outside their home countries. Why do some students study abroad? Use specific reasons and details to explain your answer.

People listen to music for different reasons and at different times. Why is music important to many people? Use specific reasons and examples to support your choice.

Groups or organizations are an important part of some people's lives. Why are groups or organizations important to people? Use specific reasons and examples to explain your answer.

Imagine that you are preparing for a trip. You plan to be away from your home for a year. In addition to clothing and personal care items, you can take **one** additional thing. What would you take and why? Use specific reasons and details to support your choice.

When students move to a new school, they sometimes face problems. How can schools help these students with their problems? Use specific reasons and examples to explain your answer.

It is sometimes said that borrowing money from a friend can harm or damage the friendship. Do you agree? Why or why not? Use reasons and specific examples to explain your answer.

Every generation of people is different in important ways. How is your generation different from your parents' generation? Use specific reasons and examples to explain your answer.

Some students like classes where teachers lecture (do all of the talking) in class. Other students prefer classes where the students do some of the talking. Which type of class do you prefer? Give specific reasons and details to support your choice.

Holidays honor people or events. If you could create a new holiday, what person or event would it honor and how would you want people to celebrate it? Use specific reasons and details to support your answer.

A friend of yours has received some money and plans to use all of it either

- to go on vacation
- to buy a car

Your friend has asked you for advice. Compare your friend's two choices and explain which one you think your friend should choose. Use specific reasons and details to support your choice.

The 21st century has begun. What changes do you think this new century will bring? Use examples and details in your answer.

What are some of the qualities of a good parent? Use specific details and examples to explain your answer.

Movies are popular all over the world. Explain why movies are so popular. Use reasons and specific examples to support your answer.

In your country, is there more need for land to be left in its natural condition or is there more need for land to be developed for housing and industry? Use specific reasons and examples to support your answer.

Many people have a close relationship with their pets. These people treat their birds, cats, or other animals as members of their family. In your opinion, are such relationships good? Why or why not? Use specific reasons and examples to support your answer.

Films can tell us a lot about the country where they were made. What have you learned about a country from watching its movies? Use specific examples and details to support your response.

Some students prefer to study alone. Others prefer to study with a group of students. Which do you prefer? Use specific reasons and examples to support your answer.

You have enough money to purchase either a house or a business. Which would you choose to buy? Give specific reasons to explain your choice.

## COLLEGE BOARD PUBLICATIONS

### USEFUL REFERENCES FOR SELECTING UNITED STATES COLLEGES

The following College Board books may be available at your local educational advising center.

The *International Student Handbook of U.S. Colleges, 2001* is a guide to higher education in the United States for international students and their advisers. It includes a directory of about 2,500 US colleges and universities, listing international student enrollments, costs, test requirements, application deadlines, and financial aid information (006496, 2000, 357 pages, **US\$25.95**, 1 lb).

The *College Handbook, 2001* with College Explorer CD-ROM for Windows is a comprehensive directory of more than 3,200 two- and four-year colleges in the United States. Its full descriptions round out the specialized information contained in the *International Student Handbook, 2001* (006445, 2000, 2,071 pages, **US\$25.95**, 5 lbs).

Both *The International Student Handbook of U.S. Colleges* and *The College Handbook* are available at a discounted price in a three-book set that also includes *Index of Majors and Graduate Degrees* (988213, **US\$49**, 8 lbs).

These publications are updated and published annually. Prices are subject to change.

Orders for the above titles must be sent with a check or money order (made payable to the College Board in US dollars), drawn on a bank in the United States and mailed to College Board Publications, Two College Way, Forrester Center, WV 25438, USA. If you have access to a fax machine, credit card orders may be placed by fax at 1-304-728-2171.

Add 35 percent of the dollar value of the order for airmail postage.

# Test Day

## ADMISSION TO THE TEST

When you go to the test center you must have:

- **Official identification.** Read pages 9 and 10 for information about the photobearing identification you must take to the test center. Your identification will be checked before you are admitted.
- **Appointment confirmation number.** This will be given to you when you schedule your appointment.
- **CBT Voucher**, if you have one.

Arrive at the test center prepared to select the institutions to which you would like your scores sent. At the end of your test, you will see a list on the computer screen, and you will be given instructions on how to select the institutions (the list is also on pages 54-58). If you plan to choose an institution in the United States, you will need to know the name of **the state** in which the institution is located. If you do not see the institution you would like to designate, ask the test center administrator for a Score Report Request Form. Fill out the form completely and return it to the test administrator **before** you leave the test center. If you do not select institutions on the test day, you must pay US\$12 per institution to have scores sent at a later date.

## TEST CENTER PROCEDURES AND REGULATIONS

The following procedures and regulations apply during the entire test session, which begins at sign-in and ends at sign-out and includes breaks.

- Report to the test center at least 30 minutes before your scheduled appointment for check-in procedures. If you arrive late, you may not be admitted and your fee will not be refunded.
- If you requested and received a CBT voucher, you must take it with you to the test center.
- The test will be given on the day and at the time assigned to you by the Prometric Candidate Services Call Center, the test center, or the RRC.
- You will be asked to complete a confidentiality statement at the test center. You cannot test and your fees will NOT be refunded if you do not sign the statement.
- Test centers do not have large waiting areas. Friends or relatives who accompany you to the test center will not be permitted to wait in the test center or contact you while you are taking the examination.
- You will be required to write your signature before and after the test session and at any time you leave or enter the testing room.
- You will be assigned a seat.
- Your picture will be taken and will be reproduced on your score report and at your testing station. Be sure the correct photograph is displayed on your assigned testing station.
- Dress so that you can adapt to any room temperature.
- You may not eat, drink, or use tobacco during the administration.
- There will be a mandatory five-minute break midway through the testing session. If you exceed the time

allotted, you may be dismissed or your scores may be canceled. If for some reason you must leave your seat at any other time, raise your hand. Timing of the section will not stop during an unscheduled break.

- You may not leave the test center during the test session and breaks.
- You may not refer to or use any testing materials or aids at any time during the testing session or breaks. These include paper, pencils, beepers, pagers, pens, calculators, watch calculators, books, pamphlets, rulers, highlighter pens, stereos or radios with headphones, telephones/cell phones, electronic dictionaries, watch alarms, dictionaries, translators, and any electronic or photographic devices.
- Scratch paper is provided following the break to aid you in organizing your essay. Scratch paper and note-taking are not permitted during the Listening and Structure sections. If you decide to handwrite your essay, writing material will be provided. Once the time has ended for the essay section, you must stop writing and hand in your essay. All scratch paper must be returned to the test center administrator.
- **You must compose an essay, and if you choose to handwrite it, you must write it on the “TOEFL CBT Handwritten Essay Form.”** If you write on anything but this form, your essay will not be scored. **Time will not start until you have received your essay form.**
- **You must answer at least one question in each section and write an essay to receive an official score report.**
- If at any time during the test you believe you have a problem with your computer or need the administrator for any reason, raise your hand.
- All testing sessions will be videotaped.

The center administrator is authorized to dismiss you from a test session, or ETS may cancel your scores for

- attempting to take the test for someone else
- failing to provide acceptable identification
- obtaining improper access to the test, a part of the test, or information about the test
- using any prohibited aid in connection with the test
- creating a disturbance
- attempting to give or receive assistance, or otherwise communicate, in any form, with another person about the test, during the test administration
- taking food or drink into the testing room
- attempting to remove test questions (in any format) from the testing room
- exceeding time permitted for the scheduled break
- attempting to remove scratch paper from the testing room
- leaving the testing room without permission
- attempting to tamper with a computer
- failing to follow any of the test administration regulations contained in this *Bulletin*, given by the test administrator, or specified in any test materials

Failure to comply with an administrator's directions can result in your test scores being canceled. If this should be necessary, no scores will be reported for this test, and **your fees will not be refunded.** You will not be eligible to register for another test until the next calendar month.

# Take the test **BEFORE** the test...

with test prep products from ETS!

## **POWERPREP® Software: Preparation for the Computer-Based TOEFL® Test**

This interactive CD-ROM is the *only* product available with two timed computer-based tests delivered just like the real test!

- *Authentic* TOEFL test questions
- Three **essay topics** for writing practice
- Samples of **actual essay responses**, written by TOEFL test takers
- A **score range** provided upon completion of each test just as you would see at the test center
- Three basic **computer-skills lessons** on how to use a mouse, scroll text, and use testing tools
- Four **test tutorials** on how to answer questions in each section of the test



## **Get the help you need to succeed!**

- Learn basic computer skills
- Become familiar with TOEFL computer-based test directions, timing, and question types
- Practice for the Writing section by using the same word processor used for the real exam
- Get your score range and gauge your readiness for the test
- Simulate testing conditions



**Price: US\$29.95 • Price outside US: US\$35.95**  
(compatible with Windows 95, 98, and NT)

# More Great Practice Materials from the Test Maker



These products provide hours of additional practice. The first three contain questions from previously administered paper-based tests AND a copy of the *TOEFL Sampler CD-ROM*.\*

**TOEFL Test Preparation Kit, 2nd Edition** contains 980 test questions and four audio cassettes with 248 minutes of recorded answer sheet instructions and Listening Comprehension material.

**Price: US\$47 • Price outside US: US\$56**

**TOEFL Practice Tests, Volume 1** contains 280 test questions and one audiocassette with 65 minutes of recorded answer sheet instructions and Listening Comprehension material.

**Price: US\$24 • Price outside US: US\$29**

**TOEFL Practice Tests, Volume 2** contains 560 test questions and two audiocassettes with 130 minutes of recorded answer sheet instructions and Listening Comprehension material.

**Price: US\$32 • Price outside US: US\$38**

**TOEFL Sampler**— gives you all the basics about the computer-based TOEFL, including test tutorials, 67 practice questions, review for the listening material, and *real* essay topics and samples to help you practice for the Writing section.

**Price: US\$15 • Price outside of US: US\$18**



\* The *TOEFL Sampler* CD-ROM provided with the *Test Preparation Kit* is for PCs only. The CD-ROM provided with the *Practice Tests, Volumes 1 and 2*, is for the PC or Macintosh. Both CD-ROMS familiarize users with the computer-based test.



## BE PREPARED. ORDER TODAY!

- Mail:** complete and mail the order form with your payment made out to TOEFL. (See page 5 for acceptable forms of payment.)
- Distribution Office:** See the inside back cover for the office nearest you. **NOTE:** In some countries, TOEFL study materials are available from local TOEFL representatives and at USIS educational advising centers. Check with the U.S. embassy or consulate for the location of the advising center nearest you. (A complete list of distributors outside the U.S. can be found on the Web at <http://www.ets.org/cbt/outsidus.html>.)

For the following services, you need to have a valid American Express®, Discover®, JCB®, MasterCard®, or VISA® credit card:

- Phone:** in the United States and Canada, call toll free 1-800-446-3319. Elsewhere, call 1-609-771-7243. Ask for Department L98.
- Online:** <http://www.ets.org/store.html>
- Fax:** 1-609-771-7385

### Method of Payment (check one)

- Bank Check  Money Order  Postal Coupons  
 Credit Card (complete the information below)

Credit Card Number

Credit Card Expiration Date (Month)   (Year)

Signature \_\_\_\_\_



TOEFL Order Services, P.O. Box 6161, Princeton, NJ 08541-6161, USA

L-99 575-70

### Please send me the following TOEFL Study Materials

ITEM #	QUANTITY	TITLE	Delivery U.S.	Delivery Elsewhere	Total Cost*
678646	_____	POWERPREP® Software	\$29.95	\$35.95	_____
678620	_____	Test Preparation Kit, 2nd ed.	\$47.00	\$56.00	_____
678640	_____	Practice Tests, Vol. 1	\$24.00	\$29.00	_____
678641	_____	Practice Tests, Vol. 2	\$32.00	\$38.00	_____
678639	_____	TOEFL Sampler CD-ROM	\$15.00	\$18.00	_____
	_____	Express Delivery (See Note #3)	\$20.00	\$20.00	_____
		Taxes (See Note #1)			_____
		Amount Enclosed			<input type="text"/>

#### NOTES:

- Orders delivered to the following U.S. states must include appropriate tax: AL, AR, CA, CO, CT, DC, FL, GA, IL, IA, KS, KY, LA, ME, MI, MD, MN, NE, NJ, NC, ND, OH, OK, PA, RI, SD, TN, TX, VA, WA, WI, WV, WY. Deliveries to Canada, add GST/HST (Reg# 13141 4468RT), excluding software.
  - Allow two to four weeks from time of order receipt for delivery.
  - Express delivery is available for an additional \$20. Delivery times vary depending on location. Delivery requires street address and telephone number.
  - Refund policy: Unopened software packages and audio kits in salable condition may be returned with original packing slip and letter of explanation within 30 days of purchase date. No other returns will be accepted.
- \* Prices subject to change. All prices are quoted in U.S. dollars.

Copyright © 2001 by Educational Testing Service, Princeton, NJ

Your Name \_\_\_\_\_

Mailing Address \_\_\_\_\_

City \_\_\_\_\_

State/Province \_\_\_\_\_

Country \_\_\_\_\_

Zip/Postal Code \_\_\_\_\_

Telephone Number \_\_\_\_\_



Copyright © 2001 by Educational Testing Service, Princeton, NJ.



## Scoring and Reporting Test Results

In the computer-adaptive TOEFL sections—Listening and Structure—your scores are based on your performance on the questions presented, the difficulty of the questions presented, and the number of questions you answered. More credit is given for correctly answering a hard question than for correctly answering an easy question.

**NOTE: You must answer at least one question in each section and compose an essay to receive an official score report.**

Your score from the Structure section will be combined with your essay rating from the Writing section to form a Structure/Writing scale score. When viewed at the test center, the Structure/Writing score will be shown in a range because your essay will not yet have been read and rated.

In the Reading section of the test, which is not adaptive, your score is also based on your performance on the questions presented, the difficulty of the questions presented, and on the number of questions you answer.

All test takers obtain scores based on the same number of questions. Pretest items may be randomly distributed in some tests, but they are not scored.

Because the content and format of the TOEFL test have changed, scores on the computer-based test are reported on new scales. These new score scales

were designed to distinguish them from those used in the paper-based test, which is still administered in a few countries. For the computer-based test, you will receive four scale scores: Listening (0 to 30), Structure/Writing (0 to 30), Reading (0 to 30), and a total score (0 to 300).

The essay you compose in the Writing section will be independently rated by two qualified readers using the Writing Scoring Guide below. Neither reader will know the rating assigned by the other. Your essay will receive the average of the two ratings unless there is a discrepancy of more than one point; in that case, a third reader will independently rate your essay. Your essay will thus receive a final rating of 6.0, 5.5, 5.0, 4.5, 4.0, 3.5, 3.0, 2.5, 2.0, 1.5, or 1. A score of 0 will be given to papers that are blank, written on scratch paper, simply copy the topic, are written in a language other than English, consist only of random keystroke characters, or are written on a topic different from the one assigned. **You are required to compose an essay.**

Your essay rating will be incorporated into the Structure/Writing scale score, with the rating of the essay constituting approximately one half of the Structure/Writing scale score. The rating will appear on your score report under the heading “essay rating.” It is provided as a service to help you and your institution better understand your Structure/Writing score.

### WRITING SCORING GUIDE

- |   |  |
|---|--|
| <p><b>6</b> An essay at this level</p> <ul style="list-style-type: none"> <li>– effectively addresses the writing task</li> <li>– is well organized and well developed</li> <li>– uses clearly appropriate details to support a thesis or illustrate ideas</li> <li>– displays consistent facility in the use of language</li> <li>– demonstrates syntactic variety and appropriate word choice</li> </ul> <p><b>5</b> An essay at this level</p> <ul style="list-style-type: none"> <li>– may address some parts of the task more effectively than others</li> <li>– is generally well organized and developed</li> <li>– uses details to support a thesis or illustrate an idea</li> <li>– displays facility in the use of the language</li> <li>– demonstrates some syntactic variety and range of vocabulary</li> </ul> <p><b>4</b> An essay at this level</p> <ul style="list-style-type: none"> <li>– addresses the writing topic adequately but may slight parts of the task</li> <li>– is adequately organized and developed</li> <li>– uses some details to support a thesis or illustrate an idea</li> <li>– demonstrates adequate but possibly inconsistent facility with syntax and usage</li> <li>– may contain some errors that occasionally obscure meaning</li> </ul> | <p><b>3</b> An essay at this level may reveal one or more of the following weaknesses:</p> <ul style="list-style-type: none"> <li>– inadequate organization or development</li> <li>– inappropriate or insufficient details to support or illustrate generalizations</li> <li>– a noticeably inappropriate choice of words or word forms</li> <li>– an accumulation of errors in sentence structure and/or usage</li> </ul> <p><b>2</b> An essay at this level is seriously flawed by one or more of the following weaknesses:</p> <ul style="list-style-type: none"> <li>– serious disorganization or underdevelopment</li> <li>– little or no detail, or irrelevant specifics</li> <li>– serious and frequent errors in sentence structure or usage</li> <li>– serious problems with focus</li> </ul> <p><b>1</b> An essay at this level</p> <ul style="list-style-type: none"> <li>– may be incoherent</li> <li>– may be undeveloped</li> <li>– may contain severe and persistent writing errors</li> </ul> <p><b>0</b> An essay will be rated 0 if it</p> <ul style="list-style-type: none"> <li>– contains no response</li> <li>– merely copies the topic</li> <li>– is off-topic, is written in a foreign language or consists only of keystroke characters</li> </ul> |
|---|--|

## COMPARING TEST SCORES

In paper-based testing, scores calculated from different test forms are made comparable by a statistical process known as score equating, which adjusts for slight differences in the difficulty level of different forms.

Scores from adaptive tests are also comparable. The questions in adaptive tests are chosen so that the difficulty level corresponds to the examinee's ability level; consequently, two examinees with different ability levels will be administered test forms that are differentially difficult. When scores are calculated, an adjustment is made to account for the differences in difficulty. Item Response Theory provides the mathematical basis for this adjustment process, which incorporates the statistical properties of the questions selected for each examinee's adaptive test form.

As in paper-based testing sessions, other aspects of the testing experiences are made as similar as possible in order to control for extraneous factors that might influence question and score performance. Factors such as average time per question and the proportion of questions covering each content area are the same for each examinee. As a

result, adaptive test scores for examinees of different ability levels are comparable.

Between November 1997 and March 1998, TOEFL collected data from more than 9,000 examinees to determine the comparability of scores earned on the computer-based TOEFL test with those earned on the paper-based test. As a result of this study, the concordance tables that follow were developed. The concordance study determined that although computer-based test scores are not directly comparable with paper-based test scores, scores of those examinees who take different computer-based and paper-based TOEFL tests can be compared in the same way that scores of examinees who take different paper-based tests are compared. These tables help score users make informed decisions about the proficiency of examinees who score in critical score ranges on either test.

If you took the paper-based test in the past and would like to compare the scores you receive on the computer-based test, you may do so by using the following tables, which list equivalent scores and score ranges on the two tests.

### CONCORDANCE TABLE: TOTAL SCORE

Paper-Based Total	Computer-Based Total	Paper-Based Total	Computer-Based Total	Paper-Based Total	Computer-Based Total
677	300	523	193	370	77
673	297	520	190	367	73
670	293	517	187	363	73
667	290	513	183	360	70
663	287	510	180	357	70
660	287	507	180	353	67
657	283	503	177	350	63
653	280	500	173	347	63
650	280	497	170	343	60
647	277	493	167	340	60
643	273	490	163	337	57
640	273	487	163	333	57
637	270	483	160	330	53
633	267	480	157	327	50
630	267	477	153	323	50
627	263	473	150	320	47
623	263	470	150	317	47
620	260	467	147	313	43
617	260	463	143	310	40
613	257	460	140		
610	253	457	137		
607	253	453	133		
603	250	450	133		
600	250	447	130		
597	247	443	127		
593	243	440	123		
590	243	437	123		
587	240	433	120		
583	237	430	117		
580	237	427	113		
577	233	423	113		
573	230	420	110		
570	230	417	107		
567	227	413	103		
563	223	410	103		
560	220	407	100		
557	220	403	97		
553	217	400	97		
550	213	397	93		
547	210	393	90		
543	207	390	90		
540	207	387	87		
537	203	383	83		
533	200	380	83		
530	197	377	80		
527	197	373	77		
				<b>Range Comparison</b>	
				Paper-Based Total	Computer-Based Total
				660-677	287-300
				640-657	273-283
				620-637	260-270
				600-617	250-260
				580-597	237-247
				560-577	220-233
				540-557	207-220
				520-537	190-203
				500-517	173-187
				480-497	157-170
				460-477	140-153
				440-457	123-137
				420-437	110-123
				400-417	97-107
				380-397	83- 93
				360-377	70- 80
				340-357	60- 70
				320-337	47- 57
				310-317	40- 47

## SECTION SCALE SCORES

### Listening

### Structure/Writing

Score-to-Score		Score-to-Score		Score-to-Score		Score-to-Score	
Paper-Based Listening Comprehension	Computer-Based Listening	Paper-Based Listening Comprehension	Computer-Based Listening	Paper-Based Structure and Written Expression	Computer-Based Structure/Writing	Paper-Based Structure and Written Expression	Computer-Based Structure/Writing
68	30	40	7	68	30	40	11
67	30	39	6	67	29	39	10
66	29	38	6	66	28	38	9
65	28	37	5	65	28	37	9
64	27	36	5	64	27	36	8
63	27	35	4	63	27	35	8
62	26	34	4	62	26	34	7
61	25	33	3	61	26	33	7
60	25	32	3	60	25	32	6
59	24	31	2	59	25	31	6
58	23			58	24		
57	22			57	23		
56	22			56	23		
55	21			55	22		
54	20			54	21		
53	19			53	20		
52	18			52	20		
51	17			51	19		
50	16			50	18		
49	15			49	17		
48	14			48	17		
47	13			47	16		
46	12			46	15		
45	11			45	14		
44	10			44	14		
43	9			43	13		
42	9			42	12		
41	8			41	11		
Score-to-Score		Range-to-Range		Score-to-Score		Range-to-Range	
Paper-Based Listening Comprehension	Computer-Based Listening	Paper-Based Listening Comprehension	Computer-Based Listening	Paper-Based Structure and Written Expression	Computer-Based Structure/Writing	Paper-Based Structure and Written Expression	Computer-Based Structure/Writing
64–68	27–30	64–68	27–30	53	20	64–68	27–30
59–63	24–27	59–63	24–27	52	20	59–63	25–27
54–58	20–23	54–58	20–23	51	19	54–58	21–24
49–53	15–19	49–53	15–19	50	18	49–53	17–20
44–48	10–14	44–48	10–14	49	17	44–48	14–17
39–43	6–9	39–43	6–9	48	17	39–43	10–13
34–38	4–6	34–38	4–6	47	16	34–38	7–9
31–33	2–3	31–33	2–3	46	15	31–33	6–7

### Reading

Score-to-Score		Score-to-Score	
Paper-Based Reading Comprehension	Computer-Based Reading	Paper-Based Reading Comprehension	Computer-Based Reading
67	30	39	9
66	29	38	9
65	28	37	8
64	28	36	8
63	27	35	7
62	26	34	7
61	26	33	6
60	25	32	6
59	25	31	5
58	24		
57	23		
56	22		
55	21		
54	21		
53	20		
52	19		
51	18		
50	17		
49	16		
48	16		
47	15		
46	14		
45	13		
44	13		
43	12		
42	11		
41	11		
40	10		
Score-to-Score		Range-to-Range	
Paper-Based Reading Comprehension	Computer-Based Reading	Paper-Based Reading Comprehension	Computer-Based Reading
64–67	28–30	64–67	28–30
59–63	25–27	59–63	25–27
54–58	21–24	54–58	21–24
49–53	16–20	49–53	16–20
44–48	13–16	44–48	13–16
39–43	9–12	39–43	9–12
34–38	7–9	34–38	7–9
31–33	5–6	31–33	5–6

## VIEWING SCORES AT THE CENTER

You will be able to view your scores on the computer screen immediately following the test. You will see your complete score for Listening and Reading, however, your Structure/Writing and total scores will be shown to you as score ranges because your essay will not yet have been read and rated. Your final score will be within the range shown on the screen. For example, you might see the following:

Listening	22
Structure/Writing	3-23
Reading	22
<b>TOTAL</b>	<b>157-223</b>

In this example, your final total score would be somewhere between 157 and 223.

To obtain the total TOEFL score, add the scale scores for the three sections and multiply by ten thirds. The example shows how the three scale section scores are used to obtain the total score.

		Structure/ Writing			
	Listening		Reading		
<b>Example:</b>	16	+	18	+	20 = 54
	$(54 \times 10) \div 3 = 180$				

**After viewing your scores on screen, you will have the option either to report or cancel them.** If you choose to report them, an official score report will be mailed to you and up to four institutions or agencies you choose as score recipients on the day of the test.

**NOTE:** Test centers do not provide receipts or printed scores for the test.

## INTERPRETING YOUR SCORES

Test scores cannot be perfectly precise. A person's score can increase or decrease just by chance from one test administration to another, even when there is no change in the person's true proficiency. The standard error of measurement is the index that describes the degree of precision in a measurement. In the case of the TOEFL test, the standard error of measurement of the total score is approximately 11 scale score points. This means that if an examinee's "true" proficiency score — the score the person would earn if the test could measure his or her ability with perfect precision — is, for example, 220, the chances are about two out of three that the person's observed score will be somewhere between 209 and 231 (220 plus or minus 11).

The TOEFL CBT Score Comparison Table will help you interpret the scores on your score record.

To illustrate the use of the table, let us assume that your total score is 180. Your section scores are 16 on Listening, 18 on Structure/Writing, and 20 on Reading.

<b>TOEFL CBT SCORE COMPARISON TABLE</b> (based on the scores of 317,708 examinees who took the test from July 1999 through June 2000)							
<b>TOTAL SCORE</b>		<b>SECTION SCORES</b>					
		<b>Listening</b>		<b>Structure/Writing</b>		<b>Reading</b>	
Your Score	Percentile Rank	Your Score	Percentile Rank	Your Score	Percentile Rank	Your Score	Percentile Rank
300		30	99	30	99	30	98
280	96	28	94	28	93	28	93
260	83	26	82	26	80	26	81
240	66	24	65	24	62	24	64
220	49	22	49	22	46	22	48
200	34	20	35	20	33	20	34
180	22	18	24	18	23	18	23
160	13	16	16	16	15	16	15
140	7	14	10	14	9	14	9
120	4	12	6	12	5	12	5
100	2	10	3	10	3	10	2
80	1	8	2	8	1	8	1
60		6	1	6	1	6	
40		4		4		4	
20		2		2		2	

First, look at the area in the table labeled "Total Score." Then, in the column under "Your Score," find the score 180. In the "Percentile Rank"\* column, opposite the 180, you will see the number 22. This number means that you achieved a higher score than approximately 22 percent of all people who took the test from July 1999 through June 2000.

Now, look at the area in the table labeled "Section Scores." For Listening, look for 16 under "Your Score." The next column, "Percentile Rank," indicates that you achieved a higher score on Listening than approximately 16 percent of all who took the test. For Structure/Writing, find the score of 18 under "Your Score." By reading across, you can see that you achieved a higher score than approximately 23 percent of the examinees on Structure/Writing. For Reading, the table shows you that, with a score of 20, you achieved a higher score on Reading than approximately 34 percent of all those who took the test.

\* The percentile rank for each score point is the percentage of examinees scoring below that score plus one-half of the percentage of examinees who achieved that score.

## INTERPRETING YOUR ESSAY RATING

Use the CBT Essay Score Comparison Table to help you interpret your score. Assume that your essay score is 4.5. Under “Your Score” in the table, find the score 4.5. In the “Percentile Rank”\* column, opposite 4.5, is the number 68. This number means that you achieved a higher score on the essay test than approximately 68 percent of all people who took the test from July 1999 through June 2000.

CBT ESSAY SCORE COMPARISON TABLE (based on the scores of 317,708 examinees who took the test from July 1999 through June 2000)			
ESSAY SCORE			
Your Score	Percentile Rank	Your Score	Percentile Rank
6.0	98	3.0	14
5.5	92	2.5	6
5.0	82	2.0	3
4.5	68	1.5	1
4.0	48	1.0	1
3.5	28	0.0	

## CANCELING YOUR SCORES

Although you will have the option of canceling your scores after the test, you should consider very carefully before doing so. Your scores will be reported to institutions only if you request them to be. If you do cancel your scores, they will not be reported to you or to any institutions, and no refund will be made.

If you cancel your scores and you decide within 60 days that you would like to have them reinstated, you may do so by sending a written request to TOEFL Services, Educational Testing Service, PO Box 6151, Princeton, NJ 08541-6151, USA. The fee for reinstatement is US\$10. Your request should include your name, date of birth, daytime phone number, appointment number, and payment (see “Acceptable Forms of Payment,” page 5). Scores will be reinstated and reported to you in approximately two weeks.

**NOTE:** You are allowed to take the test only once in a calendar month. This includes test administrations where you decide to cancel your scores. If you test more than once in a calendar month, your new scores will not be reported and your test fee will not be refunded.

\* The percentile rank for each score point is the percentage of examinees scoring below that score plus one-half of the percentage of examinees who achieved that score.

## EXAMINEE’S SCORE RECORD, OFFICIAL SCORE REPORTS

The TOEFL test payment entitles you to one printed examinee’s score record and up to four official score reports sent from ETS to designated institutions if you choose them at the center. Arrive at the test center prepared to select the institutions to which you would like your scores sent. At the end of your test, you will see a list on the computer screen and will be given instructions on how to select the institutions (the list is also on pages 54-58). If you plan to choose an institution in the United States, you will need to know the name of **the state** in which the institution is located. If you do not see an institution you would like to designate, ask the test center administrator for a Score Report Request Form. Fill out the form completely and return it to the test administrator **before** you leave the test center. If you do not select institutions on the test day, you must pay US\$12 per institution to have scores sent at a later date.

The printed score report will contain the Listening and Reading section scores that you saw at the test center, your final Structure/Writing section score, and your total score, as well as your essay rating.

**PLEASE NOTE: If you handwrite your essay, your scores will be mailed approximately five weeks after the test date. If you compose it on the computer, your scores will be mailed approximately two weeks after the test date. Under no circumstances can test results be given any earlier.** Various operational or logistical difficulties may delay the reporting of scores. Score reports are mailed within two or five weeks after the test date from the United States. Some score reporting may take longer due to difficulties with local mailing conditions or computer transmission problems.

If you have not received your score record four weeks after the test (typed essay) or seven weeks after the test (handwritten essay), write to TOEFL Services, Educational Testing Service, PO Box 6151, Princeton, NJ 08541-6151, USA, or send an email to [toefl@ets.org](mailto:toefl@ets.org).

If your **address changes** after you take the test, be sure to contact TOEFL Services in Princeton, NJ at the above address.

For information about sending score reports to additional recipients, see “Ordering Additional Official Score Reports for Institutions” on page 42.



## ORDERING ADDITIONAL OFFICIAL SCORE REPORTS FOR INSTITUTIONS

You can use the TOEFL Score Report Request Form on page 61 if you want TOEFL Services-Princeton to send official score reports to institutions other than those you indicate on the day of the test. Be sure to include your 16-digit appointment confirmation number. You cannot delete or change a designated institution after you have made a request.

**NOTE:** TOEFL scores are measurement information and are subject to all restrictions on release of information indicated in this *Bulletin*. They are not the property of the examinee.

**Scores more than two years old cannot be reported or verified.**

## SCORE VERIFICATION

Institutions are advised to request official verification of any test scores sent to them directly by examinees. If you send your examinee's score record to an institution and there is a difference between the official scores recorded at ETS and those on the score record you provided, the institution will be requested to send ETS a copy of the score record. At the written request of an official of the institution, ETS will report the official scores, as well as any previous scores recorded for you within the last two years. ETS will also provide information about your scores at the request of an institution that has a copy of your examinee's score record.

**NOTE:** The information in your TOEFL record is the same as the information printed on your examinee's score record.

## ACCEPTABLE SCORES

Each institution that requires TOEFL scores decides for itself what scores or ranges of scores are acceptable.

Language specialists prepare TOEFL test questions. These specialists follow careful, standardized procedures developed to ensure that all test material is of consistently high quality. Each question is reviewed by several members of the ETS staff. The TOEFL committee of Examiners, an independent group of professionals in the fields of linguistics, language testing, and language teaching that reports to the TOEFL Board, is responsible for the content of the tests.

After test questions have been reviewed and revised as appropriate, they are selectively administered in trial situations and assembled into computer test pools. The test pools are then reviewed according to established ETS and TOEFL program procedures to ensure that all possible versions of the computer-based test are free of cultural bias. Statistical analyses of individual questions, as well as simulated versions of the complete tests, ensure that all items provide appropriate measurement information.

These requirements vary from institution to institution, depending on such factors as your field of study, your level of study (graduate or undergraduate), whether you will be a teaching assistant, and whether the institution offers special courses in English as a foreign or second language. There is no specific passing or failing score.

If you have questions about how your scores have been used or interpreted, contact the institutions or agencies directly.

## TEST SCORE DATA RETENTION

Individually identifiable TOEFL test scores are retained in a database for only two years. After two years, all information that could identify an individual is removed. If you took the TOEFL test more than two years ago, you will have to take the test again to have the scores sent to you, an institution, or an agency.

## CONFIDENTIALITY OF TOEFL SCORES

The TOEFL program recognizes the right of examinees to privacy with regard to information that is stored in data or research files held by Educational Testing Service and the program's responsibility to protect information in its files from unauthorized disclosure.

TOEFL test score data and essay responses that may be used **at any time** for informational, research, statistical, or training purposes are not individually identifiable.

Information retained in TOEFL records is the same as the information printed on the examinee's score record and on the official score reports. An official score report will be sent only to those institutions or agencies chosen by the examinee on the day of the test, on a Score Report Request Form submitted at a later date, or otherwise specifically authorized by the examinee.

Scores are not to be released by institutional recipients without the explicit permission of the examinee.

Although ETS employs extensive quality control checks throughout the development of test questions and the preparation of final tests, typographical errors or flaws in questions may occasionally occur. If you suspect a problem and want to question a test item for any reason, notify the test supervisor before you leave the test site. You may also write to TOEFL Test Question Inquiries 42-N-208, Educational Testing Service, Rosedale Road, Princeton, NJ 08541-0001, USA, or send a fax to 1-609-683-2600 immediately after taking the test.

Please include the name of the test, the test date, the name of the center where the test was taken, and, if possible, the number of the test item being questioned.

If you have a complaint about the testing facilities or the supervisor, write to TOEFL Services within three days after the test date. Be sure to give the date of the test, the name of the test center, and the city and country in which you tested. Write to TOEFL Services, Educational Testing Service, P.O. Box 6151, Princeton, NJ, 08541-6151, USA.

# ETS Score Cancellation Policy

## TEST SECURITY ISSUES

Educational Testing Service strives to report scores that accurately reflect the performance of every test taker. Accordingly, ETS's standards and procedures for administering tests have two primary goals: giving test takers equivalent opportunities to demonstrate their abilities, and preventing some test takers from gaining an unfair advantage over others. To promote these objectives, ETS reserves the right to cancel any test score when, in ETS's judgment a **testing irregularity** occurs, there is an apparent **discrepancy in a test taker's identification**, the test taker engages in **misconduct**, the test taker attempts to use the printed work or ideas of others as their own in the essay section of the test, or the score is **invalid** for another reason. Reviews of scores by ETS are confidential. When, for any of the above reasons, ETS cancels a test score that has already been reported, it notifies score recipients of the cancellation, but it does not disclose the reason for cancellation except when authorized to do so by the test taker and in certain group cases.

## TESTING IRREGULARITIES

"Testing irregularities" refers to problems with the administration of a test. When testing irregularities occur, they may affect an individual or groups of test takers. Such problems include, without limitation, administrative errors (such as improper timing, improper seating, defective materials, and defective equipment); improper access to test content; and other disruptions of test administrations (such as natural disasters and other emergencies). When testing irregularities occur, ETS may decline to score the test, or cancel the test score. When it is appropriate to do so, ETS gives affected test takers the opportunity to take the test again as soon as possible without charge.

**NOTE:** The TOEFL program is not liable for any inconvenience, expense, or other personal damages incurred by examinees because of a rescheduled test or a delay in the reporting of scores.

Although tests are administered under strict supervision and secure conditions, irregularities may sometimes occur. Please contact ETS as soon as possible to report any observed behavior that may lead to an invalid score—for example, someone copying from another test taker, taking a test for someone else, having access to test questions before the exam, or using notes or unauthorized aids. All information will be held strictly confidential. To contact ETS, call 1-800-353-8570 (United States only); fax 1-609-406-9709; or email [treturns@ets.org](mailto:treturns@ets.org).

## IDENTIFICATION DISCREPANCIES

When, in ETS's judgment or the judgment of test center personnel, there is a discrepancy in a test taker's identification, the test taker may be dismissed from the test center; in addition, ETS may decline to score the test or cancel the test score.

## MISCONDUCT

When ETS or test center personnel find that there is misconduct in connection with a test, the test taker may be dismissed from the test center, or ETS may decline to score the test, or cancel the test score. Misconduct includes, but is not limited to, noncompliance with the "Test Center Procedures and Regulations" found on page 33 of this *Bulletin*.

## INVALID SCORES

ETS may also cancel scores if, in its judgment, there is substantial evidence that they are invalid for any other reason. Evidence of invalid scores may include, without limitation, discrepant handwriting, unusual answer patterns, and inconsistent performance on different parts of the test. Before canceling scores pursuant to this paragraph, ETS notifies the test taker in writing about its concerns, gives the test taker an opportunity to submit information that addresses ETS's concerns, considers any such information submitted, and offers the test taker a choice of options. The options include voluntary score cancellation, a free retest, or arbitration in accordance with ETS's standard Arbitration Agreement. In addition, the test taker is sent a copy of the booklet, *Why and How Educational Testing Service Questions Test Scores*, which explains this process in greater detail. (This booklet is available to any test taker at any time on request.)

**NOTE:** The retest option is not available outside the United States and Canada. The arbitration option is available only for tests administered in the United States.

# Test Centers

United States, Canada, American Samoa, Guam, US Virgin Islands, and Puerto Rico

A † next to a center means testing will take place at an institutional site i.e., a college or university. Centers marked with an \* are supplemental paper-based centers. Candidates testing at these centers must get an *Information Bulletin for Supplemental TOEFL Administrations* from TOEFL Services (see the back cover for addresses and phone numbers), the location where you obtained this *Bulletin*, or by ordering from the TOEFL Web site [www.toefl.org](http://www.toefl.org). Centers and dates will be added throughout the year. For updated information, call the Candidate Services Call Center at 1-800-GO TOEFL (1-800-468-6335) or see "Test Centers" on the TOEFL Web site at <http://www.toefl.org>.

## ALABAMA

2600	Birmingham	(205) 871-7444
2608	Decatur	(256) 350-8324
2611	Dothan	(334) 677-6334
2601	Mobile	(334) 344-6284
2603	Montgomery	(334) 262-0043
7720	Tuscaloosa	(205) 348-6760

## ALASKA

5201	Anchorage	(907) 563-6601
† 7734	Fairbanks	(907) 474-2737

## ARIZONA

† 7551	Flagstaff	(520) 523-2261
0417	Goodyear	(623) 932-7800
0413	Phoenix	(602) 548-8220
† 7510	Tempe	(480) 965-7146
† 7511	Tucson	(520) 621-7589
0409	Tucson	(520) 531-0431

## ARKANSAS

5308	Arkadelphia	(870) 230-5470
† 7553	Fayetteville	(501) 575-2743
2801	Fort Smith	(501) 484-0702
† 7521	Jonesboro	(870) 972-2038
5212	Little Rock	(501) 663-8280

## CALIFORNIA

0529	Anaheim Hills	(714) 637-7894
0594	Atascadero	(805) 462-8308
*	Bakersfield	
0536	Brea/Los Angeles	(714) 255-1141
0598	Carmel Valley	(858) 481-3640
† 7555	Chico	(530) 898-6218
0591	Culver City	(310) 337-6696
0533	Diamond Bar	(909) 861-1146
0508	Fair Oaks/ Sacramento	(916) 961-7323
† 7719	Fresno	(559) 278-8362
0596	Gardena	(310) 329-1844
5863	Glendale	(818) 545-7383
9035	Irvine	(949) 552-0563
0510	La Mesa	(619) 668-2121
7501	Oakland	(510) 873-8100
0505	Palm Desert	(760) 836-1510
0587	Piedmont	(510) 428-4123
0531	Rancho Cucamonga	(909) 944-9763
0556	Redlands	(909) 792-2145
0528	Riverside	(909) 353-8600
† 7715	San Bernardino	(909) 880-5388
† 7556	San Diego	(619) 594-0968
0558	San Francisco	(415) 681-3769
5849	San Francisco	(415) 882-1212
0008	San Jose	(408) 257-7699
† 7534	San Luis Obispo	(805) 756-1551
0515	Santa Rosa	(707) 579-5163
0552	Walnut Creek	(925) 934-3099
9091	Westlake Village	(805) 495-6367

## COLORADO

† 7559	Boulder	(303) 492-5854
1204	Colorado Springs	(719) 593-1272
† 7558	Denver	(303) 556-3677
5812	Denver	(303) 692-8745
† 7557	Fort Collins	(970) 491-5060
5376	Glendale	(303) 758-8774
*	Grand Junction	
1220	Longmont	(303) 485-3218
1213	Pueblo	(719) 545-0838

## CONNECTICUT

2411	Glastonbury	(860) 659-0400
2403	Hamden	(203) 287-9677
2416	Norwalk	(203) 847-0031

## DELAWARE

† 7518	Newark	(302) 831-6717
9065	Wilmington	(302) 998-3817

## DISTRICT OF COLUMBIA

5216	Washington	(202) 955-5887
† 7716	Washington	(202) 806-6428

## FLORIDA

0600	Casselberry	(407) 671-2332
† 7561	Coral Gables	(305) 284-2450
9074	Davie	(954) 423-0782
0621	Ft. Myers	(941) 275-1130
0629	Gainesville	(352) 371-6891
9077	Hollywood	(954) 967-0443
0601	Jacksonville	(904) 739-3000
5836	Maitland	(407) 875-8118
† 7512	Miami	(305) 237-1015
9072	Miami Lakes	(305) 825-2708
0623	Sarasota	(941) 923-9399
0011	Sarasota	(941) 923-4889
† 7560	St. Petersburg	(727) 864-8163
0617	Tallahassee	(850) 386-8707
0657	Tampa (South)	(813) 289-1246
† 7562	Tampa (South)	(813) 974-2742
0620	Temple Terrace	(813) 989-9988

## GEORGIA

3021	Albany	(912) 878-1192
† 7563	Albany	(912) 430-1631
† 7541	Athens	(706) 542-8378
5804	Atlanta	(404) 255-9957
5340	Atlanta	(404) 651-3816
3010	Augusta	(706) 868-1888
† 7722	Columbus	(706) 565-3562
3005	Jonesboro	(770) 478-5356
3012	Macon	(912) 405-7423
0026	Marietta	(770) 980-1117
3007	Savannah	(912) 354-2660
3024	Valdosta	(912) 245-1069

## HAWAII

† 7530	Hilo	(808) 974-7370
6713	Honolulu	(808) 441-5095
3103	Kailua	(808) 263-6656

## IDAHO

2000	Boise	(208) 322-3555
† 7565	Moscow	(208) 885-6716
† 7538	Pocatello	(208) 236-4506

## ILLINOIS

3225	Carbondale	(618) 529-4664
† 7542	Champaign	(217) 244-1342
5230	Chicago	(312) 641-7300
5861	Chicago	(312) 609-2525
3209	Homewood	(708) 798-0238
5385	Lombard	(630) 434-7943
3216	Northbrook	(847) 559-2461
3207	Peoria	(309) 682-0825
3204	Springfield	(217) 546-0381
3231	Sycamore	(815) 748-0074
3222	Westchester	(708) 947-2800

## INDIANA

1807	Evansville	(812) 479-6855
1806	Fort Wayne	(219) 436-2710
1800	Indianapolis	(317) 257-7546
1802	Indianapolis	(317) 247-7664
1810	Lafayette	(765) 447-5996
1815	Merrillville	(219) 736-1113
1811	Mishawaka	(219) 254-1055
1809	Terre Haute	(812) 232-6348

## IOWA

5341	Ames	(515) 294-6214
3301	Bettendorf	(319) 359-1001
† 7564	Iowa City	(319) 335-0355
3304	Sioux City	(712) 258-6063
3300	West Des Moines	(515) 223-6650

## KANSAS

*	Hays	
† 7566	Lawrence	(785) 864-2772
† 7545	Pittsburg	(316) 235-4173
1504	Topeka	(785) 272-7500
1502	Wichita	(316) 651-5350

## KENTUCKY

1104	Lexington	(859) 268-3338
1101	Louisville	(502) 423-0478

## LOUISIANA

5233	Baton Rouge	(225) 293-8489
† 7567	Baton Rouge	(225) 388-1145
1308	Bossier City	(318) 742-7349
† 7540	Monroe	(318) 342-5349
1315	New Orleans	(504) 245-2600
† 7568	New Orleans	(504) 280-1092

## MAINE

5264	Orono	(207) 581-1708
3400	Portland	(207) 775-5812

## MARYLAND

5315	Baltimore	(443) 923-6400
3512	Bethesda	(301) 718-9893

## Maryland (continued)

† 7571	College Park	(301) 314-0319
9086	Columbia	(410) 740-8137
3514	Lanham	(301) 552-3400
9083	Pikesville	(410) 486-9045
3519	Salisbury	(410) 341-4100
0046	Towson	(410) 823-9788

## MASSACHUSETTS

5135	Boston	(617) 345-8980
2520	Braintree	(781) 380-3876
† 7569	Bridgewater	(508) 531-1780
2519	Brookline	(617) 264-4152
2517	East Longmeadow	(413) 525-4901
5653	Lexington	(781) 861-0723
5855	Waltham	(781) 890-0466
0005	Worcester	(508) 853-7250

## MICHIGAN

5478	Ann Arbor	(734) 973-9328
† 7513	East Lansing	(517) 355-8278
2301	Grand Rapids	(616) 957-0368
2306	Lansing	(517) 372-7413
2312	Livonia	(734) 462-2750
† 7526	Marquette	(906) 227-1745
† 7550	Mt. Pleasant	(517) 774-1092
2303	Portage	(616) 321-8351
5682	Southfield	(248) 827-2627
*	Traverse City	
2305	Troy	(248) 643-7323
2314	Utica	(810) 739-0270

## MINNESOTA

† 7543	Bedford	(218) 755-2075
0800	Bloomington	(612) 831-7461
0805	Duluth	(218) 723-1494
† 7572	Minneapolis	(612) 624-5520
† 7516	Moorhead	(218) 236-2118
5404	Rochester	(507) 292-9713
† 7517	St. Cloud	(320) 654-5456
0806	St. Cloud	(320) 529-4830
0803	Woodbury	(651) 702-6791

## MISSISSIPPI

† 7574	Hattiesburg	(601) 266-6123
3600	Jackson	(601) 366-6400
† 7546	Mississippi State	(662) 325-6610
3603	Tupelo	(662) 844-2121

## MISSOURI

0702	Ballwin	(636) 394-7742
0711	Cape Girardeau	(573) 339-2017
† 7539	Columbia	(573) 884-0911
0031	Hazelwood	(314) 895-1887
0718	Jefferson City	(573) 761-7517
† 7573	Kansas City	(816) 235-1635
† 7582	Kirksville	(660) 785-4438
0700	Springfield	(417) 882-0740
0713	St. Joseph	(816) 671-9900
5677	St. Louis	(314) 993-9092

Test Centers – United States, Canada, American Samoa, Guam, US Virgin Islands, and Puerto Rico (continued)

**MONTANA**

3700 Billings (406) 656-4646  
 † 7732 Bozeman (406) 994-6984  
 3702 Helena (406) 443-9205  
 † 7544 Missoula (406) 243-6257

**NEBRASKA**

3805 Columbus (402) 564-2862  
 † 7525 Kearney (308) 865-8054  
 3804 Lincoln (402) 465-8800  
 3800 Omaha (402) 334-9449  
 † 7577 Omaha (402) 554-4800

**NEVADA**

2201 Las Vegas (702) 889-4132  
 2203 Reno (775) 829-9779

**NEW HAMPSHIRE**

4003 Portsmouth (603) 433-6800

**NEW JERSEY**

9064 Deptford (609) 384-4744  
 4119 Fairlawn (201) 475-1670  
 4104 Hamilton (609) 631-9794  
 4103 Toms River (732) 349-4609  
 5871 Union (908) 964-2862  
 4110 Verona (973) 857-5412

**NEW MEXICO**

1900 Albuquerque (505) 296-0609  
 † 7528 Roswell (505) 624-7227

**NEW YORK**

4226 Albany (518) 869-6119  
 0019 Brooklyn Heights (718) 222-1277  
 4219 Buffalo (716) 565-0570  
 † 7579 Buffalo (716) 645-2232  
 4204 East Syracuse (315) 433-9038  
 4215 Garden City (516) 746-7367  
 4217 Ithaca (607) 277-4821  
 4225 Manhasset (516) 869-1236  
 5823 Melville (631) 845-9063  
 5832 Midtown Manhattan (212) 809-5509  
 5867 New York (212) 858-4461  
 5864 New York (212) 986-5661  
 4231 Queens/Rego Park (718) 997-6356  
 4218 Rochester (716) 385-4810  
 4228 Staten Island (718) 980-3079  
 4216 Vestal (607) 798-1715  
 4206 Wappingers Falls (914) 298-8378  
 5416 Whitehall (212) 269-6848  
 4202 White Plains (914) 289-0437

**NORTH CAROLINA**

1608 Asheville (828) 253-4224  
 † 7576 Boone (828) 262-6801  
 5475 Charlotte (704) 364-7758  
 † 7578 Durham (919) 530-7490  
 † 7552 Fayetteville (910) 485-8921  
 1617 Gastonia (704) 853-2038  
 2058 Greensboro (336) 854-4230  
 1607 Greenville (252) 756-0342  
 1602 Raleigh (919) 846-1933  
 1624 Salisbury (704) 633-8444  
 1609 Wilmington (910) 392-0891  
 † 7549 Wilmington (910) 962-7444

**NORTH DAKOTA**

4301 Bismarck (701) 224-1171  
 4300 Fargo (701) 293-1234

**OHIO**

1419 Centerville (937) 435-8417  
 0007 Cincinnati (513) 671-7030  
 † 7702 Cincinnati (513) 556-7173  
 † 7700 Cleveland (216) 368-1030  
 1409 Columbus (614) 451-4652  
 † 7701 Columbus (614) 292-2241  
 1437 Hilliard (614) 529-4232  
 1440 Lima (419) 331-7323  
 1427 Mentor (440) 255-0055  
 1420 Niles (330) 652-1886  
 1410 Reynoldsburg (614) 864-4090  
 1402 Stow (330) 922-5587  
 1421 Strongsville (440) 238-0530  
 7733 Toledo (419) 530-3266  
 5355 Toledo (419) 530-3266

**OKLAHOMA**

0902 Oklahoma City (405) 843-8378  
 † 7703 Stillwater (405) 744-5958  
 5472 Tulsa (918) 747-9333

**OREGON**

0110 Eugene (541) 485-4589  
 † 7704 Eugene (541) 346-2772  
 0111 Milwaukie (503) 659-9575  
 0105 Portland (503) 254-2009

**PENNSYLVANIA**

1710 Allentown (610) 791-5320  
 1736 Clarks Summit (570) 586-4362  
 1730 Erie (814) 864-6100  
 1718 Harrisburg (717) 652-0143  
 \* Indiana  
 \* Kingston  
 1731 Lancaster (717) 391-6519  
 6720 Montgomeryville (215) 855-5251  
 1722 North Wales (215) 412-7822  
 1726 Philadelphia (215) 238-8380  
 1700 Pittsburgh (412) 247-4463  
 1705 Pittsburgh (412) 367-4620  
 † 7705 Pittsburgh (412) 624-9103  
 1733 York (717) 755-7471

**RHODE ISLAND**

3900 Cranston (401) 942-8552

**SOUTH CAROLINA**

† 7706 Columbia (803) 777-2782  
 2100 Greenville (864) 676-1506  
 2110 Myrtle Beach (843) 293-2955

**SOUTH DAKOTA**

4400 Sioux Falls (605) 362-4875  
 \* Rapid City

**TENNESSEE**

1010 Chattanooga (423) 894-6249  
 1011 Clarksville (931) 647-2003  
 1018 Franklin (615) 790-5018  
 † 7537 Jackson (901) 425-3297  
 † 7523 Johnson City (423) 439-7842  
 1001 Knoxville (423) 690-2677  
 1015 Madison (615) 860-0376  
 † 7721 Martin (901) 587-7702  
 1006 Memphis (901) 266-4606  
 \* 7707 Memphis (901) 678-1457

**TEXAS**

0335 Abilene (915) 698-7858  
 0317 Amarillo (806) 463-2379  
 9042 Arlington (817) 572-6690  
 0012 Austin (512) 441-1978

**Texas (continued)**

† 7710 Austin (512) 232-2643  
 0322 Beaumont (409) 899-9798  
 † 7531 Brownsville (956) 544-8875  
 0311 Clear Lake (281) 286-8537  
 † 7536 College Station (979) 862-7992  
 0329 Corpus Christi (361) 993-3793  
 5811 Dallas (972) 385-1181  
 † 7709 Denton (940) 369-7617  
 † 7711 Edinburg (956) 316-2457  
 0344 El Paso (915) 587-7323  
 9080 Ft. Worth (817) 858-0084  
 † 7514 Houston (713) 743-5444  
 † 7708 Houston (713) 313-7386  
 0326 Kingwood (281) 361-9243  
 \* Laredo (806) 785-4400  
 0318 Lubbock (972) 686-3310  
 9026 Mesquite (915) 520-9418  
 0319 Midland (936) 468-3958  
 † 7548 New Canoches (830) 629-3808  
 0358 New Braunfels (210) 494-7263  
 0339 San Antonio (210) 431-4370  
 5339 San Antonio (281) 491-9200  
 0003 Sugar Land (281) 491-9202  
 0004 Sugar Land (281) 491-9202  
 5309 Tyler (903) 510-2842  
 0320 Waco (254) 772-2467  
 7729 Wichita Falls (940) 397-6276

**UTAH**

4503 Ogden (801) 394-5990  
 4504 Orem (801) 226-5544  
 5343 Salt Lake City (801) 581-7310  
 \* St. George

**VERMONT**

5209 Williston (802) 872-0845

**VIRGINIA**

† 7712 Fairfax (703) 993-2390  
 5365 Fairfax (703) 204-9060  
 4723 Lynchburg (804) 832-0778  
 4722 Mechanicsville (804) 730-5844  
 4709 Newport News (757) 873-0208  
 4718 Roanoke (540) 344-3688

**WASHINGTON**

† 7529 Ellensburg (509) 963-1847  
 0015 Mountlake Terrace (425) 774-3922  
 0211 Puyallup (253) 848-0771  
 0200 Spokane (509) 467-8715

**WEST VIRGINIA**

4801 Charleston (304) 744-4144  
 † 7522 Huntington (304) 696-2604  
 5354 Morgantown (304) 293-0700

**WISCONSIN**

4903 Brookfield (414) 796-0808  
 † 7535 Eau Claire (715) 836-5070  
 4906 Fox Point (414) 540-2223  
 † 7714 La Crosse (608) 785-8968  
 5323 Madison (608) 231-6270  
 † 7519 Oshkosh (920) 424-1423  
 4905 Racine (414) 554-9009  
 † 7520 Stevens Point (715) 346-4472

**WYOMING**

5000 Casper (307) 235-0070  
 † 7547 Laramie (307) 766-2188

**US TERRITORIES AND PUERTO RICO**

**AMERICAN SAMOA**

5254 Pago Pago (684) 633-5995

**GUAM**

5500 Agana (671) 477-0700

**PUERTO RICO**

5221 Guaynabo (787) 753-6394

**VIRGIN ISLANDS**

5255 St. Croix (340) 773-5751

**CANADA**

**ALBERTA**

6017 Calgary (403) 777-1365  
 6018 Edmonton (403) 444-6110  
 \* Fort McMurray  
 \* Grande Prairie

**BRITISH COLUMBIA**

\* Fort St. John  
 6028 Vancouver/Coquitlam (604) 464-6401  
 6027 Vancouver/Richmond (604) 231-1966  
 6046 Vancouver/Tsawwassen (604) 943-6022  
 7554 Victoria (250) 472-4501

**MANITOBA**

6022 Winnipeg (204) 988-5050

**NEW BRUNSWICK**

\* Fredericton

**NEWFOUNDLAND**

5263 St. John's (709) 724-8901

**NOVA SCOTIA**

\* Antigonish  
 6032 Halifax (902) 422-7323

**ONTARIO**

6042 Cambridge (519) 622-4479  
 6005 Etobicoke (416) 236-2629  
 \* Kingston (519) 657-4124  
 6000 London (613) 745-8391  
 \* Ottawa (613) 745-8391  
 \* Sudbury  
 \* Thunder Bay  
 6033 Whitby (905) 404-1818  
 6066 Windsor (519) 974-8747

**PRINCE EDWARD ISLAND**

\* Charlottetown

**QUEBEC**

5259 Montreal (514) 876-8818  
 \* Sainte-Foy

**SASKATCHEWAN**

\* Regina  
 6063 Saskatoon (306) 978-7323

# Test Centers Outside United States, Canada, American Samoa, Guam, US Virgin Islands, and Puerto Rico

Find your country and region number in the list below, and then contact your Regional Registration Center (RRC) to schedule your testing appointment. **NOTE: A † next to a center means the test is being given at an institutional site, such as a local college or university. Centers marked with a ■ are permanent centers, where testing is available throughout the year. Centers with an \* are supplemental paper-based centers.** If you plan to test at a supplemental center, you must obtain an *Information Bulletin for Supplemental TOEFL Administrations* prepared for these locations. This *Bulletin* contains testing schedules and locations and is available directly from TOEFL Services (see back cover for addresses and phone numbers). It is also available from the institution where you obtained this *Bulletin* and the TOEFL Web site, [www.toefl.org](http://www.toefl.org).

If “call the RRC” appears in the “CBT Center” column, **CALL THE RRC IMMEDIATELY** to determine the availability of testing dates. In these locations testing is limited. Call the phone number given below for the appropriate RRC. To schedule an appointment at one of these locations, refer to the instructions on page 7.

Visit the TOEFL Web site at [www.toefl.org](http://www.toefl.org) for updates to this list because there may be changes after this *Bulletin* is printed. If there is no test center in your country or within 200 kilometers of the city where you live AND it is impossible to test at one of the listed locations, contact ETS to see if arrangements for testing can be made.

**NOTE:** When calling an RRC that is located outside the country from which you are calling, you must dial the international access number first.

## Regional Registration Centers (RRC)

### Region 1: Prometric

P.O. Box 5343\*\*  
Chatswood, N.S.W. 2057  
Australia

Registration Phone: **61-2-9903-9797**  
Fax: **61-2-9415-3105**

### Region 2: The International Educational Foundation/Prometric

Menara Imperium  
28th Floor, Suite B  
Jalan H.R. Rasuna Said  
Metropolitan Kuningan  
Super Blok Kav. No 1  
12980 Jakarta, Indonesia

Registration Phone: **62-21-831-7304**  
Fax: **62-21-831-7306**

### Region 3: Prometric KK

Kayabacho Tower 15F  
1-21-2 Shinkawa, Chuo-ku  
Tokyo 104-0033 Japan

Registration Phone: **81-3-5541-4800**  
Fax: **81-3-5541-4810**

### Region 4: The Korean-American Educational Commission (KAEC)/Prometric

M.P.O. Box 112 \*\*  
Seoul, 121-600  
Republic of Korea

Registration Phone: **82-2-3211-1233**  
Fax: **82-2-3275-4029**

### Region 5: Prometric, Inc.

Latin America/Caribbean RRC  
3110 Timanus Lane, Suite 200  
Baltimore, MD 21244  
USA

Registration Phone: **1-443-923-8160**  
Fax: **1-443-923-8569**

### Region 6: Prometric

PO Box 12964\*\*  
50794 Kuala Lumpur  
Malaysia

Registration Phone: **60-3-7628-3333**  
Fax: **60-3-7628-3366**

### Region 7: AMIDEAST/Prometric

P.O. Box 96\*\*  
Magles El Shaab  
Dokki, Cairo, Egypt

Registration Phone: **20-2-337-8973**  
Fax: **20-2-749-0972**

### Region 9: Prometric

P.O. Box 218\*\*  
Auckland Park, 2006  
South Africa

Registration Phone: **27-11-713-0600**  
Fax: **27-11-482-4062**

### Region 10: The Language Training & Testing Center (LTTC)/Prometric

P.O. Box 23-41\*\*  
Taipei 106  
Taiwan R.O.C.

Registration Phone: **886-2-8194-0200**  
Fax: **886-2-2363-8840**

### Region 11: Institute of International Education (IIE)/Prometric

G.P.O. Box 2050\*\*  
Bangkok 10501  
Thailand

Registration Phone: **66-2-2000-733**  
Fax: **66-2-6392-706**

### Region 12: CITO Group/Prometric

P.O. Box 1109\*\*  
6801 BC Arnhem  
The Netherlands

Registration Phone: **31-26-352-1577**  
Fax: **31-26-352-1278**

### Region 12: Courier Service

CITO Group/Prometric  
Nieuwe Oeverstraat No. 50  
6811 JB Arnhem  
The Netherlands

Email: [registration@citogroep.nl](mailto:registration@citogroep.nl)

### Region 14: Prometric

Senior Plaza, 160-A, Guatam Nagar  
Yusuf Sarai:  
Behind Indian Oil Bldg.  
New Delhi 110049 India  
Phone: **91-11-651-1649**  
Fax: **91-11-652-9741**

\*\* If sending materials via express mail, contact the RRC for an alternate form of address.

RRC #	COUNTRY NAME	CITY	TEST CENTER #	CBT CENTER	SUPPLEMENTAL CENTER
12	ALBANIA	Tirana			*
7	ALGERIA	Algiers			*
9	ANGOLA	Luanda			*
5	ANTIGUA & BARBUDA	St. Johns			*
5	ARGENTINA	Buenos Aires Chubut/Comodora Cordoba Mar del Plata Mendoza Rosario	8303	■	* * * * *

**Test Centers — Outside United States, Canada, American Samoa, Guam, US Virgin Islands, and Puerto Rico** *(continued)*

RRC #	COUNTRY NAME	CITY	TEST CENTER #	CBT CENTER	SUPPLEMENTAL CENTER		
<b>Argentina continued</b>							
		Tucuman			*		
12	ARMENIA	Yerevan	8955	■			
5	ARUBA	Oranjestad			*		
1	AUSTRALIA	Adelaide	8403	■	*		
		Brisbane			*		
		Cairns			*		
		Canberra			*		
		Hobart			*		
		Melbourne			8408	■	
		Perth			8409†	■	
Sydney	8401	■					
12	AUSTRIA	Vienna	8004	■			
12	AZERBAIJAN	Baku			*		
5	BAHAMAS	Freeport			*		
7	BAHRAIN	Manama	8707†	■			
6	BANGLADESH	Dhaka	8815	■			
5	BARBADOS	Bridgetown			*		
12	BELARUS	Minsk			*		
12	BELGIUM	Brussels	8005	■			
5	BELIZE	Belize City			*		
9	BENIN	Cotonou			*		
5	BERMUDA	Paget			*		
5	BOLIVIA	Cochabamba	8314	■	*		
		La Paz			*		
		Santa Cruz			*		
		Sucre			*		
12	BOSNIA AND HERZEGOVINA	Sarajevo			*		
9	BOTSWANA	Gaborone	8218	■			
5	BRAZIL	Belem		■	*		
		Belo Horizonte			8365	*	
		Brasilia			8317	*	
		Curitiba			8318	*	
		Fortaleza			8319	*	
		Londrina				*	
		Manaus				*	
		Porto Alegre			8324	■	
		Recife			8325	■	
		Rio de Janeiro			8326	■	
		Sao Carlos					*
		Salvador			8327	■	
		Sao Paulo			8328	■	
6	BRUNEI DARUSSALAM	Bandar Seri Begawan			*		
12	BULGARIA	Sofia	8007	■	*		
		Varna			*		
9	BURKINA FASO	Ouagadougou			*		
9	BURUNDI	Bujumbura			*		
6	CAMBODIA	Phnom Penh			*		
9	CAMEROON	Yaounde	8223†	■			
9	CAPE VERDE	Praia			*		
9	CENTRAL AFRICAN REP.	Bangui			*		
9	CHAD	N'Djamena			*		

**Test Centers — Outside United States, Canada, American Samoa, Guam, US Virgin Islands, and Puerto Rico** *(continued)*

RRC #	COUNTRY NAME	CITY	TEST CENTER #	CBT CENTER	SUPPLEMENTAL CENTER
5	CHILE	Antofagasta Santiago	8329	■	*
5	COLOMBIA	Barranquilla Bogota Bucaramanga Cali Medellin	8332 8331 8360 8334	■ ■ ■ ■	*
5	COSTA RICA	San Jose	8335	■	
9	COTE D'IVOIRE	Abidjan	8243	Call the RRC	
12	CROATIA	Zagreb	8009†	■	
12	CYPRUS	Nicosia North Nicosia	8012 8013	■ ■	
12	CZECH REPUBLIC	Prague	8014	■	
9	DEMOCRATIC REPUBLIC of the CONGO	Kinshasa Lubumbashi			* *
12	DENMARK	Copenhagen	8015	■	
9	DJIBOUTI	Djibouti			*
5	DOMINICAN REPUBLIC	Santo Domingo	8336†	■	
5	ECUADOR	Guayaquil Quito	8337 8338	■ ■	
7	EGYPT	Cairo	8708	■	
5	EL SALVADOR	San Salvador	8339	■	
9	ERITREA	Asmara	8233		*
12	ESTONIA	Tallinn			*
9	ETHIOPIA	Addis Ababa	8234†	Call the RRC	
1	FIJI	Suva			*
12	FINLAND	Helsinki Oulu	8022	■	*
12	FRANCE	Ajaccio (Corse) Bordeaux Lyon Marseille Nice Paris Rennes Strasbourg Toulouse	8024 8026† 8027 8028 8029 8032 8033	■ ■ ■ ■ ■ ■ ■ ■	*  *
9	GABON	Libreville			*
9	GAMBIA	Banjul			*
7	GAZA STRIP	Gaza			*
12	GEORGIA	Tbilisi	8958	■	
12	GERMANY	Berlin Dusseldorf Frankfurt Freiburg Hamburg Munich	8034 8035 8036 8037	■ ■ ■ ■	*  *
9	GHANA	Accra	8238	■	
12	GREECE	Athens Thessaloniki	8038 8039	■ ■	
5	GRENADA	St. George's			*
5	GUADELOUPE	Pointe-a-Pitre			*

**Test Centers — Outside United States, Canada, American Samoa, Guam, US Virgin Islands, and Puerto Rico** *(continued)*

RRC #	COUNTRY NAME	CITY	TEST CENTER #	CBT CENTER	SUPPLEMENTAL CENTER
5	GUATEMALA	Guatemala City	8344	■	
9	GUINEA	Conakry			*
5	GUYANA	Georgetown			*
5	HAITI	Port-Au-Prince			*
5	HONDURAS	La Ceiba San Pedro Sula Tegucigalpa	8349	■	* *
6	HONG KONG	Hong Kong	8591	■	
12	HUNGARY	Budapest	8042	■	
12	ICELAND	Reykjavik	8043	■	
14	INDIA	Ahmadabad Allahabad Bangalore Calcutta Hyderabad Madras Mumbai Mumbai Usefi New Delhi Trivandrum	8902 8903 8904 8906 8908 8909 8921 8905 8901 8912	■ ■ ■ ■ ■ ■ ■ ■ ■ ■	
2	INDONESIA	Banda Aceh Bandung Denpasar Jakarta Manado Medan Palembang Pekanbaru Surabaya Tembagapura Ujungpandang Yogyakarta	8801 8806 8812	■ Call the RRC ■	* * * * * * * * * * *
12	IRELAND	Dublin	8044†	■	
12	ISRAEL	Tel Aviv	8049	■	
12	ITALY	Bari Bologna Milan Poli Milan Naples Palermo Rome Sassari (Sardinia) Trieste	8052 8153† 8053† 8055	■ ■ ■ ■	* * * * *
5	JAMAICA	Kingston	8352†	■	
3	JAPAN	Fukuoka Hiroshima Ishikawa Kochi Miyazaki Nagoya Okinawa Osaka Sapporo Sendai Tokyo CIEE Tokyo Kayabacho	8602 8603 8613 8604 8605 8606 8607 8608 8609	■ ■ ■ ■ ■ ■ ■ ■ ■	* * *

**Test Centers — Outside United States, Canada, American Samoa, Guam, US Virgin Islands, and Puerto Rico** *(continued)*

RRC #	COUNTRY NAME	CITY	TEST CENTER #	CBT CENTER	SUPPLEMENTAL CENTER
<b>Japan continued</b>		Tokyo Temple	8611†	■	
		Yokohama	8612	■	
7	JORDAN	Amman	8712	■	
12	KAZAKHSTAN	Alma-ATA	8959	■	
9	KENYA	Mombasa			*
		Nairobi	8282	■	
4	KOREA	Seoul	8683	■	
		Taegu	8682	■	
7	KUWAIT	Kuwait City	8714	■	
12	KYRGYZSTAN	Bishkek			*
6	LAOS	Vientiane			*
12	LATVIA	Riga			*
7	LEBANON	Antelias	8715	■	
		Beirut	8716	■	
9	LESOTHO	Roma			*
9	LIBERIA	Monrovia			*
12	LITHUANIA	Vilnius	8058†	■	
12	LUXEMBOURG	Luxembourg			*
12	MACEDONIA, former Rep. of Yugoslavia	Skopje			*
9	MADAGASCAR	Antananarivo			*
9	MALAWI	Zomba			*
6	MALAYSIA	Johore Baharu			*
		Kota Kinabalu	8852†	■	
		Kuala Lumpur	8851	■	
		Kuala Lumpur MACEE	8858	■	
		Kuching	8853	■	
		Penang	8854	■	
		Tawau/Sabah			*
9	MALI	Bamako			*
12	MALTA	Msida			*
1	MARSHALL ISLANDS	Jaluit			*
		Kwajalein			*
		Majuro			*
5	MARTINIQUE	La Mentin			*
9	MAURITANIA	Nouakchott			*
9	MAURITIUS	Port Louis	8255†	■	
5	MEXICO	Guadalajara	8355	■	
		Hermosillo			*
		LaPaz			*
		Mazatlan			*
		Merida			*
		Mexicali (Baja, CA)			*
		Mexico City	8362	■	
		Monterrey	8363†	■	
		Morelia			*
		Puebla			*
		Queretaro			*
		Tamaulipas			*
		Torreón/Coahuila			*
		Vera Cruz			*

**Test Centers — Outside United States, Canada, American Samoa, Guam, US Virgin Islands, and Puerto Rico** *(continued)*

RRC #	COUNTRY NAME	CITY	TEST CENTER #	CBT CENTER	SUPPLEMENTAL CENTER
1	MICRONESIA, Federated States of	Colonia (Yap) Kolonja (Pohnpei) Koror (Palau) Kosrae Weno (Chuuk)			*
12	MOLDOVA	Chisinau			*
6	MONGOLIA	Ulaanbaatar	8849	■	
7	MOROCCO	Ifrane Rabat	8717	■	*
9	MOZAMBIQUE	Maputo			*
6	MYANMAR	Rangoon			*
9	NAMIBIA	Windhoek			*
6	NEPAL	Kathmandu	8914	■	
5	NETHERLANDS ANTILLES	Willemstad (Curacao)			*
12	NETHERLANDS	Arnhem Woerden	8002 8001	■ ■	
1	NEW CALEDONIA	Noumea			*
1	NEW ZEALAND	Auckland Christchurch Dunedin Wellington	8425 8426†  8432	■ ■  ■	*
5	NICARAGUA	Managua	8373†	■	
9	NIGER	Niamey			*
9	NIGERIA	Abuja Lagos Port Harcourt	8259 8263	■ ■	*
1	NORTHERN MARIANA ISLANDS	Saipan			*
12	NORWAY	Bergen Kristiansand Oslo Tromso Trondheim	8066  8068  8072	■  ■  ■	*
7	OMAN	Muscat	8718†	■	
6	PAKISTAN	Islamabad Karachi Lahore	8782 8781 8783	■ ■ ■	
5	PANAMA	Panama City	8374	■	
5	PARAGUAY	Asuncion			*
5	PERU	Arequipa Lima Trujillo	8377	■	*
6	PHILIPPINES	Cagayan de Oro Cebu City Davao City Manila	8473†  8475	■  ■	*
12	POLAND	Gdansk Poznan Warsaw	8073	■	*
12	PORTUGAL	Lisbon Porto	8074†	■	*
7	QATAR	Doha	8719†	■	
9	REUNION	St. Denis			*
12	ROMANIA	Bucharest Cluj Iasi	8076 8077†	■ ■	*

**Test Centers — Outside United States, Canada, American Samoa, Guam, US Virgin Islands, and Puerto Rico** *(continued)*

RRC #	COUNTRY NAME	CITY	TEST CENTER #	CBT CENTER	SUPPLEMENTAL CENTER
12	RUSSIAN FEDERATION	Ekaterinburg			*
		Krasnodar			*
		Krasnojarsk			*
		Moscow	8951	■	
		Novosibirsk	8952	■	
		Rostov-Na-Donu			*
		Saratov			*
		St. Petersburg	8953	■	
		Tomsk			*
		Vladivostok			*
Volgograd			*		
9	RWANDA	Kigali			*
9	SÃO TOMÉ & PRÍNCIPE	São Tomé			*
7	SAUDI ARABIA	Damman-Men	8722†	■	
		Damman-Women	8742†	■	
		Jeddah-Men	8723†	■	
		Jeddah-Women	8713†	■	
		Riyadh-Men	8724	■	
		Riyadh-Women	8743	■	
9	SENEGAL	Dakar	8266†	■	
9	SIERRA LEONE	Freetown			*
6	SINGAPORE	Singapore	8855	■	
12	SLOVAKIA	Bratislava			*
		Kosice			*
12	SLOVENIA	Ljubljana			*
1	SOLOMON ISLANDS	Honiara			*
9	SOUTH AFRICA	Bloemfontein			*
		Cape Town	8205	■	
		Durban	8206†	■	
		Johannesburg	8201	■	
12	SPAIN	Barcelona	8085†	■	
		Las Palmas (Canary Islands)			*
		Madrid	8087†	■	
		Mallorca			*
		Oviedo			*
		Pamplona	8092†	■	
		Santiago de Compostela			*
		Seville			*
Valencia			*		
6	SRI LANKA	Colombo	8857†	■	
5	ST. VINCENT	Kingstown			*
5	SURINAME	Paramaribo			*
9	SWAZILAND	Mbabane			*
12	SWEDEN	Goteborg	8095	■	
		Lulea			*
		Lund	8107†	■	
		Stockholm	8097	■	
		Umea			*
12	SWITZERLAND	Geneva	8099†	■	
		Montreux			*
		St. Gallen			*
		Zurich	8103	■	
7	SYRIA	Aleppo			*
		Damascus	8727	■	
1	TAHITI	Papeete			*
10	TAIWAN	Kaohsiung	8587	■	
		Taipei	8581	■	
12	TAJIKISTAN	Dushanbe			*

**Test Centers — Outside United States, Canada, American Samoa, Guam, US Virgin Islands, and Puerto Rico** *(continued)*

RRC #	COUNTRY NAME	CITY	TEST CENTER #	CBT CENTER	SUPPLEMENTAL CENTER
9	TANZANIA	Dar es Salaam Moshi	8269†	■	*
11	THAILAND	Bangkok Bangkok Pathuwan Chiang Mai Songkh	8461 8481 8462	■ ■ ■	*
9	TOGO	Lome			*
1	TONGA	Nukualofa			*
5	TRINIDAD AND TOBAGO	St. Augustine			*
7	TUNISIA	Tunis	8728	■	
12	TURKEY	Adana Ankara Eskisehir Istanbul Izmir	8703†   8701† 8705†	■   ■ ■	*  *
12	TURKMENISTAN	Ashgabat			*
9	UGANDA	Kampala	8274†	■	
12	UKRAINE	Kharkov Kiev L'viv Odessa	8964	■	*  * *
7	UNITED ARAB EMIRATES	Abu Dhabi Dubai	8729 8733	■ ■	
12	UNITED KINGDOM	Belfast, N. Ireland Glasgow, Scotland Llantwit Major, Wales London, England Manchester, England Swanage, England Twickenham, England	8064 8078†  8017 8018†  8101	■ ■  ■ ■  ■	*   *
5	URUGUAY	Montevideo			*
12	UZBEKISTAN	Tashkent	8966	■	
5	VENEZUELA	Caracas Merida Maracaibo	8385  8386	■  ■	*  *
6	VIETNAM	Danang Hanoi Ho Chi Minh City (Saigon)	8476	■	*  *
7	WEST BANK	East Jerusalem Hebron Ramallah	8735	■	*  *
7	YEMEN	Sana'a	8738	■	
12	YUGOSLAVIA	Belgrade			*
9	ZAMBIA	Lusaka	8276†	■	
9	ZIMBABWE	Bulawayo Harare	8277†	■	*

# List A: Institution Codes

Agencies and institutions listed here are approved to receive TOEFL scores. At the test center, you will be able to view this list on the computer. Some approved institutions and agencies may not be listed. In that case, contact the institution or agency directly to get its code number. NOTE: If you are applying for graduate study, see List B: Department Codes.

## Abbreviations Used in List A

Acad. .... Academy	Educ. .... Education or Educational	Jr. .... Junior	Prog. .... Program
Agric. .... Agriculture or Agricultural	Exch. .... Exchange	Mgt. .... Management	Sch. .... School
Assoc. .... Association	Fdn. .... Foundation	Mech. .... Mechanical	Sci. .... Science or Sciences
C. .... College	Grad. .... Graduate or Graduates	Med. .... Medical	St. .... Saint or State
Ctr. .... Center	Hosp. .... Hospital	Mt. .... Mount or Mountain	Tech. .... Technical, Technological, or Technology
Comm. .... Community	H.S. .... High School	P.A.O. .... Public Affairs Officer	U. .... University
Commsn. .... Commission	Inst. .... Institute	P.O. .... Polytechnic or Polytechnical School	
Dept. .... Department	Intl. .... International	Prof. .... Professions or Professional	

## Agencies and Institutions in the United States

### ALABAMA (AL)

- 9069 Air University
- 1003 AL Agric. Mech. U., Normal
- 1006 AL St. U., Montgomery
- 1024 Athens St. U., Athens
- 1005 Auburn U., Auburn
- 1036 Auburn U., Montgomery
- 1262 Gadsden St. Comm. C., Gadsden
- 1303 Huntingdon C., Montgomery
- 1736 Jacksonville St. U., Jacksonville
- 1352 Jefferson St. Comm. C., Birmingham
- 1302 Samford U., Birmingham
- 1738 Troy St. U., Troy
- 1813 Tuskegee U., Tuskegee
- 1856 U. of AL, Birmingham
- 1854 U. of AL, Huntsville
- 1830 U. of AL, University (or Tuscaloosa)
- 1515 U. of Mobile, Mobile
- 1004 U. of Montevallo, Montevallo
- 1735 U. of North AL, Florence
- 1880 U. of South AL, Mobile
- 1737 U. of West AL, Livingston

### ALASKA (AK)

- 4896 U. of AK, Anchorage
- 4866 U. of AK, Fairbanks
- 4897 U. of AK, Juneau

### ARIZONA (AZ)

- 9680 Arizona Board of Med. Examiners
- 4007 AZ St. U., Tempe:
  - Project 1000
- 4633 Embry Riddle Aeronautical U.
- 4331 Grand Canyon U., Phoenix
- 4513 Mesa Comm. C.
- 4623 Pima Comm. C.
- 4006 Northern AZ U., Flagstaff
- 4003 Thunderbird American Grad. S. Intl. Mgt., Glendale
- 4832 U. of AZ, Tucson
- 4998 Western Intl. U., Phoenix
- 4996 Yavapai C., Prescott

### ARKANSAS (AR)

- 6011 AR St. U., State University
- 6010 AR Tech. U., Russellville
- 6272 Henderson State U., Arkadelphia
- 6273 Hendrix C., Conway
- 6661 Southern AR U., Magnolia
- 8049 Subiaco Academy, Subiaco
- 6866 U. of AR, Fayetteville
- 6368 U. of AR, Little Rock:
  - Med. Sciences
- 6901 U. of AR, Pine Bluff
- 6004 U. of Central AR, Conway
- 6012 U. of Central AR, Conway
- 6658 Williams Baptist C., College City
- 9538 Winrock Intl., Morrilton

### CALIFORNIA (CA)

- 4207 Academy of Art C., San Francisco
- 9760 American Film Inst., LA
- 4008 Armstrong U., Berkeley
- 4009 Art Center C. of Design, Pasadena
- 9335 Asia Fdn., San Francisco
- 9601 Aspect Foundation, San Francisco
- 4596 Azusa Pacific U.
- 4021 Bethany C., Santa Cruz
- 4017 Biola U., La Mirada
- 4228 Brooks Inst. Photography, Santa Barbara
- 4084 Cabrillo C., Aptos
- 4094 CA Baptist C., Riverside
- 9769 CA Board of Pharmacy, Sacramento
- 9319 CA Board of Registered Nursing, Sacramento
- 4031 CA C. of Arts & Crafts, Oakland
- 4123 CA Christian C.
- 4049 CA Inst. of Arts, Valencia
- 4807 CA Inst. of Integral Studies, San Francisco
- 4034 CA Inst. of Tech., Pasadena
- 4088 CA Lutheran U., Thousand Oaks
- 9068 CA Sch. Culinary Arts
- 4128 CA Sch. Prof. Psychology, San Francisco
- California State Universities:**
  - 4110 — Bakersfield

### (California cont.)

- 4048 — Chico
- 4098 — Dominguez Hills (Carson)
- 4312 — Fresno
- 4589 — Fullerton
- 4011 — Hayward
- 4345 — Humboldt
- 4389 — Long Beach
- 4399 — Los Angeles
- 4707 — Northridge
- 4082 — Pomona (Polytech)
- 4671 — Sacramento
- 4099 — San Bernardino
- 4682 — San Diego
- 4684 — San Francisco
- 4687 — San Jose
- 4038 — San Luis Obispo (Polytech)
- 5677 — San Marcos
- 4723 — Sonoma
- 4713 — Stanislaus, Turlock
- 4802 CA Western Sch. of Law, San Diego
- 4109 Canada C., Redwood City
- 4073 Cerritos C., Norwalk
- 4725 Chabot C., Hayward
- 4047 Chapman U., Orange
- 4051 Citrus C., Glendora
- 4052 City C. of San Francisco
- 4053 Claremont Grad. Sch., Claremont
- 4054 Claremont McKenna C., Claremont
- 4710 Claremont Sch. of Theology
- 4061 C. of Marin, Kentfield
- 4063 C. of Notre Dame, Belmont
- 4070 C. of San Mateo, San Mateo
- 4087 C. of the Siskiyous, Weed
- 4943 Contra Costa C., San Pablo
- 4121 Cosumnes River C., Sacramento
- 4106 Cypress C.
- 4286 De Anza C., Cupertino
- 4235 Diablo Valley C., Pleasant Hill
- 4284 Dominican C. of San Rafael
- 4296 East Los Angeles C., Monterey Park
- 4302 El Camino C., Torrance
- 4273 Evergreen Valley C.
- 4315 Foothill C., Los Altos Hills
- 4311 Fresno City C.
- 4313 Fuller Theological Seminary, Pasadena
- 4314 Fullerton C.
- 9144 Gemological Inst. of America, Santa Monica
- 4327 Glendale Comm. C., Glendale
- 4328 Golden Gate Baptist Theological Seminary, Mill Valley
- 4329 Golden Gate U., San Francisco
- 4339 Golden West C., Huntington Beach
- 4336 Grad. Theological Union, Berkeley
- 4334 Grossmont Comm. C., El Cajon
- 4341 Harvey Mudd C., Claremont
- 4340 Hartnell C., Salinas
- 4343 Heald Inst. of Tech., San Francisco
- 4059 Holy Names C., Oakland
- 4347 Hsi Lai U.
- 4346 Humphreys C., Stockton
- 4773 Irvine Valley C., Irvine
- 4365 John F. Kennedy U., Orinda
- 4406 Laney C., Oakland
- 4380 La Sierra U., Riverside
- 4386 Lincoln U., San Francisco
- 4062 Loma Linda U., Loma Linda
- 4068 Loma Linda U., Sch. of Dentistry
- 4388 Long Beach City C.
- 4391 Los Angeles City C.
- 4395 Los Angeles Harbor C., Wilmington
- Los Angeles Marin Comm. C.:**
  - 4061 — C. of Marin Campus, Kentfield
  - 4361 — Indian Valley Campus, Novato
- 4398 Los Angeles Pierce C., Los Angeles (or Woodland Hills)
- 4400 Los Angeles Trade Tech. C.
- 4401 Los Angeles Valley C., Van Nuys
- 4403 Loyola Marymount U., LA
- 4483 Menlo C., Atherton
- 4502 Merritt C., Oakland
- 4485 Mills C., Oakland
- 4582 Mira Costa C., Oceanside
- 7587 Mission C., Santa Clara
- 4507 Monterey Inst. of Intl. Studies
- 4490 Monterey Peninsula C.
- 4493 Mt. St. Mary's C., LA
- 4494 Mt. San Antonio C., Walnut

### (California cont.)

- 4557 National U., San Diego
- 4581 Occidental C., Los Angeles
- 4579 Ohlone C., Fremont
- 4584 Orange Coast C., Costa Mesa
- 4394 Otis C. of Art & Design, LA
- 4591 Oxnard C., Oxnard
- 4638 Pacific Grad. Sch. of Psychology, Palo Alto
- 9625 Pacific Rim Language Inst.
- 4602 Palomar C., San Marcos
- 4604 Pasadena City C.
- 4630 Pepperdine U., Malibu
- 4619 Pitzer C., Claremont
- 4605 Point Loma Nazarene U., San Diego
- 4607 Pomona C., Claremont
- 4689 Rancho Santiago C., Santa Ana
- 4670 Sacramento City C.
- 4747 Saddleback C., Mission Viejo
- 4675 Saint Mary's C. of CA, Moraga
- 9955 Salvation Army (CFOT), Rancho Palos Verdes
- 4681 San Diego City C.
- 4735 San Diego Mesa C.
- 4682 San Diego St. U.:
- 9546 — American Language Inst.
- 4036 San Francisco Art Inst.
- 4744 San Francisco Conservatory of Music
- 4684 San Francisco St. U.
- 4721 San Francisco St. U. Col. of Ext. Learning
- 4683 San Francisco St. U. Grad. Div.
- 4756 San Jose Christian C.
- 4686 San Jose City C.
- 4687 San Jose St. U.
- 4690 Santa Barbara City C.
- 4851 Santa Clara U.
- 4691 Santa Monica C.
- 4692 Santa Rosa Jr. C.
- 4693 Scripps C., Claremont
- 4746 Skyline C., San Bruno
- 4723 Sonoma St. U., Rohnert Park
- 7802 Southern CA Inst. Architecture, Santa Monica
- 4704 Stanford U.
- 4820 Taft C.
- 4828 Thomas Aquinas C., Santa Paula
- 4039 United States Intl. U., San Diego
- 4833 U. of CA — Berkeley:
  - 9216 — Extension, English Language Prog.
- 4834 U. of CA — Davis
- 4795 U. of CA Edu Abroad Pgm
- 4859 U. of CA — Irvine
- U. of CA — Los Angeles**
  - 4837 — Extension
  - 4839 U. of CA — Riverside
  - 4836 U. of CA — San Diego (LaJolla)
  - 4840 U. of CA — San Francisco, Med. Ctr.
  - 4835 U. of CA — Santa Barbara
  - 4860 U. of CA — Santa Cruz
  - 4831 U. of LaVerne, LaVerne
  - 4892 U. of the Pacific, San Francisco, Dental Sch.
  - 4065 U. of the Pacific, Stockton
  - 4848 U. of Redlands
  - 4849 U. of San Diego
  - U. of San Francisco:**
    - 4850 — Sch. of Law
    - 4792 U. of Southern CA, Los Angeles:
    - 4793 — Sch. of Dentistry
    - 4931 Ventura C.
    - 4966 West Coast U., Los Angeles
    - 4964 West Los Angeles C., Culver City
    - 4958 West Valley C., Saratoga
    - 4152 Western U., Pomona
    - 4952 Whittier C.
    - 4955 Woodbury U., Burbank
    - 4994 Yuba C., Marysville

### COLORADO (CO)

- 4001 Adams State C., Alamosa
- 4072 CO C., Colorado Springs
- 4073 CO Sch. of Mines, Golden
- 4075 CO St. U., Fort Collins
- 4137 Community C. of Denver Economics Inst., Boulder
- 4294 Metropolitan St. C. of Denver
- 3342 Naropa U., Boulder
- 4656 Regis U., Denver
- 9547 St. Scholastica Acad., Canon City
- 4841 U. of CO, Boulder
- 4874 U. of CO, Colorado Springs

### (Colorado cont.)

- 4875 U. of CO, Denver
- 4877 U. of CO, Health Sci. Ctr., Denver
- 4842 U. of Denver
- 4356 — ILLIFF Sch. of Theology, Denver
- 4074 U. of Northern CO, Greeley
- 4918 U. of Phoenix, CO
- 4611 U. of Southern CO, Pueblo
- 4830 U.S. Air Force Academy
- CONNECTICUT (CT)**
  - 9407 Belgian-American Educ. Fdn., New Haven
  - 3898 Central CT St. U., New Britain
  - 9365 Comm. of Pharmacy, Hartford
  - 3284 CT C., New London
  - 3966 Eastern CT St. U., Willimantic
  - 2869 Educ. Futures, New Canaan
  - 3390 Fairfield U., Fairfield
  - 3677 Norwalk Comm. Tech. C.
  - 3712 Quinnipiac U., Hamden
  - 3780 Sacred Heart U., Fairfield
  - 3662 Southern CT St. U., New Haven
  - 3899 Trinity C., Hartford
  - 3914 U. of Bridgeport
  - U. of CT, Farmington:**
    - 3938 — Dental
    - 3931 — Health Sciences Center
    - 3934 — Med. Sch.
    - 3915 U. of CT, Storrs
    - 3436 U. of Hartford, West Hartford
    - 3663 U. of New Haven, West Haven
    - 5807 U.S. Coast Guard Academy, New London
    - 3959 Wesleyan U., Middletown
    - 3350 Western CT St. U., Danbury
    - 3997 Yale Law Sch., New Haven
    - Yale U., New Haven:**
      - 3987 — Dept. of Religious Studies
      - 3995 — Divinity Sch.
      - 7072 — Inst. of Sacred Music
      - 3985 — Sch. of Architecture
      - 3992 — Sch. of Art
      - 3992 — Sch. of Nursing
      - 3986 — Sch. of Organization & Mgt.

### DELAWARE (DE)

- 5153 DE St. U., Dover
- 5255 Goldey-Beacom C., Wilmington
- 5811 U. of DE, Newark
- 5894 Wesley C., Dover
- DISTRICT OF COLUMBIA (Washington, DC)**
  - 5093 Acad. for Educ. Development (AED), Botswana Proj.
  - 8172 Acad. for Educ. Development (GTD), ENI/RUS
  - 5283 ACTR/ACCELS, Freedom Support Act
  - 9107 Agency for Intl. Development
  - 5023 Agency for Intl. Development (AID) Office of Intl. Training
  - 5007 American U.
  - 5027 AMIDEAST
  - 5104 Catholic U. of America
  - 9905 Embassy of Botswana
  - 5727 Embassy of the Arab Republic of Egypt
  - 9246 Embassy of India
  - 9109 Embassy of Japan
  - 9323 Embassy of Kuwait
  - 9141 Embassy of Malaysia
  - 9324 Embassy of Republic of Slovenia
  - George Washington U.:**
    - 5241 — Elliott Sch. Intl. Affairs
    - 5245 — Sch. of Engineering & Applied Science
  - Georgetown U.:**
    - 5244 — Grad. Public Policy Prog.
    - 5335 Howard Hughes Med. Inst., Pre-Doctoral Fellowship Prog.
    - 5297 Howard U.
    - 9616 Inst. Intl. Educ. (Hubert Humphrey FHP Prog.)
    - 9314 Intl. Road Federation
    - 9250 Intl. Student Exch. Prog. (ISEP)
    - 9920 IREX/CEEG (Central & E. European Fellowship)
    - 5610 Johns Hopkins U., Sch. of Advanced Intl. Studies
    - 5422 Mount Vernon C.
    - 0073 National Research Council
    - 9358 Organization of American States
    - 9362 Pan American Health Organization (PAHO)
    - 5622 Southeastern U.

### (District of Columbia cont.)

- 5632 Strayer C.
- 9516 Transcendancy Corp.
- 5796 Trinity C.
- 9525 United States Dept. of Agric.
- 9250 U. Mission of Tunisia
- 5929 U. of the District of Columbia
- 9362 World Health Organization (WHO)
- FLORIDA (FL)**
  - 0878 American C., Switzerland
  - 5040 Art Inst. of Ft. Lauderdale
  - 5053 Barry U., Miami Shores
  - 8196 Colegio Intl. De Caracas
  - 5159 Daytona Beach Comm. C.
  - 9904 Dept. Veterans Affairs, Med. Ctr., Miami
  - 5223 Eckerd C., St. Petersburg
  - 5190 Embry-Riddle Aeronautical U., Daytona Beach
  - 8200 Equity American Sch., Miami Sggs.
  - 5215 FL Agric. Mech. U., Tallahassee
  - 9579 FL Board of Nursing, Jacksonville
  - 9682 FL Board of Pharmacy, Tallahassee
  - 5229 FL Atlantic U., Boca Raton
  - 5232 FL Comm. C., Jacksonville
  - 5080 FL Inst. of Tech., Melbourne
  - 5206 FL Intl. U., Miami
  - 5218 FL Southern C., Lakeland
  - 5219 FL St. U., Tallahassee
  - 5431 Jacksonville U.
  - 5437 Lynn U., Boca Raton
  - 5465 Miami-Dade Comm. C., Med. Center, Miami
  - 5160 Miami-Dade Comm. C. North, Miami
  - 5458 Miami-Dade Comm. C. South, Miami
  - 5457 Miami-Dade Comm. C., Wolfson Campus, Miami
  - 5506 New C. of U. of So. FL, Sarasota
  - 9850 Northwood U., W. Palm Bch.
  - 5514 Nova Southeastern U., Fort Lauderdale
  - 5553 Palm Beach Atlantic C., Palm Beach
  - 5531 Palm Beach C.C., Lake Worth
  - 5572 Rollins C., Winter Park
  - 5638 St. Leo C., St. Leo
  - 5606 St. Petersburg Jr. C.
  - 5076 St. Thomas U., Miami
  - 5653 Santa Fe Comm. C., Gainesville
  - 0835 Schiller Intl. U., Dunedin
  - 5630 Stetson U., Deland
  - 5794 Tallahassee Comm. C.
  - 5233 U. of Central FL, Orlando
  - 5812 U. of FL, Gainesville
  - 5815 U. of Miami, Coral Gables
  - 5802 U. of Miami, Latin Training
  - 5756 U. of Miami, Medical School
  - 5490 U. of North FL, Jacksonville
  - 5828 U. of South FL, Tampa
  - 5819 U. of Tampa
  - 5833 U. of West FL, Pensacola
  - 5869 Valencia C.C., Orlando
  - 5893 Webber C., Babson Park
- GEORGIA (GA)**
  - 5002 Agnes Scott C., Decatur
  - 5725 Atlanta Metro. C.
  - 5336 Augusta State U., Augusta
  - 5066 Brenau U., Gainesville
  - 5068 Brewton-Parker C., Mt Vernon, GA
  - 5110 Clark Atlanta U., Atlanta
  - 5123 Columbus St. U.
  - 5187 Emory U., Atlanta
  - 9692 GA Baptist C. of Nursing, Atlanta
  - 9189 GA Board of Nursing, Atlanta
  - 5252 GA C. & St. U., Milledgeville
  - 5248 GA Inst. of Tech., Atlanta
  - 5165 GA Perimeter C.
  - 5285 GA Rotary Student Fund, Savannah
  - 5253 GA Southern U., Statesboro
  - 5250 GA Southwestern St. U., Americus
  - 7259 GA St. Examining Boards, Atlanta
  - 5251 GA St. U., Atlanta
  - 5359 Kennesaw St. U., Kennesaw
  - 5362 La Grange C.
  - 5308 Life C., Marietta
  - Med. C. of GA, Augusta:**
    - 5425 — Sch. of Dentistry
  - 5025 Mercer U., Atlanta, Stetson S. Business
  - 5409 Mercer U., Macon
  - 5521 Ogilthorpe U., Atlanta
  - 5631 Savannah C. Art & Design

**(Georgia cont.)**

5626 Southern Poly. St. U., Marietta  
5900 State U. of W. Ga., Carrollton  
5813 U. of GA, Athens  
5855 Valdosta St. U.

**HAWAII (HI)**

4106 Brigham Young U., Laie  
4105 Chaminate U. of Honolulu  
4351 Hi Loa C., Kaneohe  
4352 Hi Pacific U., Honolulu  
4350 Honolulu Comm. C.  
4377 Kapiolani Comm. C., Honolulu  
4378 Kaula Comm. C., Lihue Kauai  
4410 Leeward Comm. C., Pearl City  
4510 Maui Comm. C., Kahului, Maui  
4869 U. of HI, at Hilo  
4867 **U. of HI, at Manoa, Honolulu:**  
4868 — East & West Center  
9310 — Summer Session

**IDAHO (ID)**

4018 Boise St. U.  
4114 C. of Southern Idaho, Twin Falls  
4385 Lewis-Clark St. C., Lewiston  
4355 ID St. U., Pocatello  
4657 Ricks C., Rexburg  
4843 U. of Idaho, Moscow

**ILLINOIS (IL)**

1025 Augustana C., Rock Island  
1070 Bradley U., Peoria  
1118 Chicago St. U.  
1083 C. of Dupage, Glen Ellen, IL  
1135 Columbia C., Chicago  
1165 De Paul U., Chicago  
1667 Dominican U., River Forest  
1199 Eastern IL U., Charleston  
1212 Educ. Comm. for Foreign  
Veterinary Grad., Schaumburg  
Finch U. of Health Science.,  
Chicago Med. Sch.  
9103 Foreign Pharmacy Grad. Exam.  
Comm'n., Park Ridge  
1263 Governors St. U., U. Park  
9694 Health Professionals Intl., Winnetka  
1318 IL Inst. of Tech., Chicago/West  
1319 IL St. U., Normal  
1320 IL Wesleyan U., Bloomington  
9900 Inst. of European & Asian  
Studies, Chicago  
9686 Intl. Health Care, Inc., Joliet  
1344 John Marshall Law Sch.,  
Chicago  
1379 Knowledge Systems Inst.,  
Skokie  
1372 Knox C., Galesburg  
1392 Lake Forest C.  
1412 Loyola U., Chicago  
9295 Lutheran World Federation,  
Chicago  
1470 Millikin U., Decatur  
1486 Moody Bible Inst., Chicago  
1555 North Central C., Naperville  
1556 North Park U. & Theological  
Seminary, Chicago  
1090 Northwestern IL U., Chicago  
1559 Northern IL U., DeKalb

**Northwestern U.:**  
1547 — Medical Sch., Chicago  
1699 — Medl. Sch. of Journalism,  
Evanston  
— Sch. of Music  
3732 Oakton Comm. C., Des Plaines  
1573 Olivet Nazarene U., Kankakee  
1596 Parkland C., Champaign  
1621 Parks C. of St. Louis U.,  
Cahokia  
1630 Principia C., Elsah  
1665 Rockford C.  
1666 Roosevelt U., Chicago  
9386 Rotary Intl., Evanston  
1676 Rush U., Grad. C., Chicago  
(Rush U.)  
1708 Saint Xavier U., Chicago  
1713 Sch. of the Art Inst., Chicago  
1726 Southern IL U., Carbondale  
1759 Southern IL U., Edwardsville  
1797 Trinity Evangelical Divinity Sch.,  
Deerfield

1111 Truman C., Chicago  
1832 U. of Chicago  
1819 U. of Chicago, Grad. Sch.  
Business, Ph.D. Prog.  
1851 U. of IL, Chicago  
1855 U. of IL, Health Sci. Center,  
Chicago  
1787 U. of IL, Springfield  
1836 **U. of IL, Urbana:**  
9563 — Office of Intl. Agric., Urbana  
1900 Western IL U., Macomb  
1905 Wheaton C., Wheaton

**INDIANA (IN)**

9773 ADNOC Scholarship Program,  
Bloomington  
1051 Ball St. U., Muncie  
1073 Butler U., Indianapolis  
1166 DePauw U., Greencastle  
1195 Earlham C., Richmond  
1251 Goshen C.  
9257 Health Prof. Bureau,  
Indianapolis  
1323 IN Inst. of Tech., Fort Wayne  
1322 IN St. U., Terre Haute  
1324 IN U., Bloomington  
1339 IN U., South Bend  
1336 IN U. — Purdue U. at Ft. Wayne

**(Indiana cont.)**

1325 IN U. — Purdue U. at  
Indianapolis  
1585 Oakland City U.  
1631 Purdue U., West Lafayette  
1668 Rose-Hulman Inst. of Tech.,  
Terre Haute  
1702 St. Mary's C., Notre Dame  
1802 Taylor U., Upland  
1811 Tri-St. U., Angola  
1208 U. of Evansville  
1321 U. of Indianapolis  
1841 U. of Notre Dame  
1693 U. of St. Francis, Fort Wayne  
1874 Valparaiso U.  
1877 Vincennes U.  
1895 Wabash C., Crawfordsville

**IOWA (IA)**

9231 American Assoc U. Women  
6047 Buena Vista U., Storm Lake  
6087 Central C., Pella  
6099 Clarke C., Iowa  
6101 Coe C., Cedar Rapids  
6119 Cornell C., Mt. Vernon  
6168 Drake U., Des Moines  
6249 Graceland U., Lamoni  
6252 Grinnell C.  
6306 IA St. U., Ames  
6375 Luther C., Decorah  
4497 Maharishi U. of Mgt., Fairfield  
6593 Palmer C. of Chiropractic,  
Davenport  
6869 U. of Dubuque  
6681 U. of IA, Iowa City  
6307 U. of Northern IA, Cedar Falls  
6885 Upper Iowa U., Fayette  
6925 Waldorf C., Forest City  
6926 Wartburg C., Waverly

**KANSAS (KS)**

6031 Baker U., Baldwin  
6056 Benedictine C., Atchison  
6037 Bethel C., Kansas  
6088 Central Christian C., McPherson  
6335 Emporia St. U.  
6218 Fort Hays St. U., Hays  
6224 Friends U., Wichita  
6274 Hesston C.  
6325 Johnson County Comm. C.,  
Overland Park  
6334 KS St. U., Manhattan  
6337 KS Wesleyan U., Salina  
6547 Ottawa U.  
6336 Pittsburg St. U.  
6895 U. of KS, Kansas City, Med. Ctr.  
6871 U. of KS, Lawrence  
6928 Washburn U., Topeka  
6884 Wichita St. U.

**KENTUCKY (KY)**

1060 Berea C., Berea  
1056 Bellarmine U., Louisville  
1097 Campbellsville U.  
1200 Eastern KY U., Richmond  
1368 KY St. U., Frankfort  
1487 Morehead St. U.  
1494 Murray St. U.  
1574 Northern KY U., Highland  
Heights  
1724 Southern Baptist Theological  
Seminary, Louisville  
1825 Union C., Barbourville  
1837 U. of KY, Lexington  
1838 U. of Louisville  
1901 Western KY U., Bowling Green

**LOUISIANA (LA)**

6250 Grambling State U.  
9739 LA St. BD. Phys. Therapy,  
Lafayette  
6373 LA St. U., Baton Rouge  
**New Orleans:**  
6385 — Medical Center  
6352 — Sch. of Allied Health  
6356 LA St. U. Med. Center,  
Shreveport  
6372 LA Tech. U., Ruston  
6374 Loyola U., New Orleans  
6403 McNeese St. U., Lake Charles  
6221 Nicholls St. U., Thibodaux  
6492 Northwestern St. U.,  
Natchitoches  
6656 Southeastern LA U., Hammond  
6663 Southern U. A. & M. C.,  
Baton Rouge  
6832 Tulane U., New Orleans  
6872 U. of LA, Lafayette  
6482 U. of LA, Monroe  
6379 U. of New Orleans

**MAINE (ME)**

3076 Bates C., Lewiston  
3089 Bowdoin C., Brunswick  
3280 Colby C., Waterville  
3505 ME Maritime Academy, Castine  
9913 ME St. Board of Nursing,  
Augusta  
3916 U. of ME, Orono  
3691 U. of Southern ME, Portland

**MARYLAND (MD)**

5401 Bowie St. U.  
5114 C. of Notre Dame of Md., Baltimore  
5144 C. of Southern MD., La Plata  
5890 Columbia Union C., Takoma  
Park  
5122 Coppin St. C., Baltimore  
5402 Frostburg St. U.

**(Maryland cont.)**

5257 Goucher C., Towson  
5296 Hood C., Frederick  
**Johns Hopkins U., Baltimore:**  
5610 — Advanced Intl. Studies  
5332 — Arts & Sciences  
5532 — Peabody Inst.  
5354 — Sch. of Medicine  
5767 — Sch. of Nursing (Grad.)  
8585 — Sch. of Professional  
Studies  
5352 — Sch. of Public Health  
5370 Loyola C., Baltimore  
9197 MD Board of Nurses, Baltimore  
9687 MD Board of Physical Therapy  
Examiners, Baltimore  
9637 MD Board of Physician Quality  
Assurance, Baltimore  
5399 MD Inst. C. of Art, Baltimore  
9197 MD St. Board of Examiners-  
Nurses, Baltimore

5440 Montgomery C., Rockville  
5414 Montgomery C., Takoma Park  
5416 Morgan St. U., Baltimore  
9953 Natl. Bd. Certified Occ. Therapy,  
Gaithersburg  
5587 RETS Tech. Training Center,  
Baltimore  
5601 St. Marys C., St. Marys City  
5403 Salisbury State U., Salisbury  
5404 Towson St. U.  
5824 Uniformed Services U. of the  
Health Sciences, Bethesda

5810 U. of Baltimore  
5848 U. of MD, Baltimore City (Grad.)  
5835 U. of MD, Baltimore County,  
Catonsville  
5814 U. of MD, College Park  
5400 U. of MD, Eastern Shore, Princess  
Anne  
9088 U. of MD, Mannheim  
5804 U. of MD, U.C., College Park  
5809 U.S. Naval Academy, Annapolis  
5888 Washington C., Chestertown  
5931 Washington Theological Union,  
Silver Spring  
5898 Western MD C., Westminster

**MASSACHUSETTS (MA)**

3002 American Intl. C., Springfield  
3003 Amherst C.  
3777 Art Institute of Boston  
3015 Arthur D. Little Mgt. Educ. Inst.,  
Cambridge  
3009 Assumption C., Worcester  
3075 Babson C., Wellesley  
3078 Bay Path C., Longmeadow  
3096 Bentley C., Waltham  
3107 Berkshire C. of Music, Boston  
3252 Berkshire Sch.  
8018 Worcester Academy

**Boston C., Chestnut Hill:**  
3033 — Master Finance  
3052 — Ph.D. Finance  
3010 — Ph.D. Organization Studies  
3084 Boston Conservatory, Boston  
**Boston U.:**  
9034 — Admin. Studies Prog.  
9040 — Arts Admin. Prog.  
9627 — Banking & Law Prog.  
3245 — C. of Communication  
3105 — C. of Engineering  
3081 — Dental Sch.  
3108 — Metropolitan College  
3028 — Sargent C., Allied  
Health Prof.  
— Sch. of Education  
3101 — Sch. of Public Health  
3082 — Sch. of the Arts  
3092 — Grad. Sch. Arts & Sci.  
3091 Bradford C.

**Brandeis U., Waltham:**  
3122 — Grad. Sch. of Intl. Econ. &  
Finance  
3097 — Heller Grad. Sch.  
3517 Bridgewater St. C.  
3123 Bunker Hill Comm. C., Boston  
9641 Cambridge Sch., Weston  
3279 Clark U., Worcester  
3282 C. of the Holy Cross, Worcester  
3285 Curry C., Milton  
3352 Dean C., Franklin  
9577 Deerfield Acad.  
3367 Emerson C., Boston  
9606 Emmanuel C., Boston  
3369 Endicott C., Beverly  
3391 Fisher C., Boston  
3518 Fitzburg St. C.  
3519 Framingham St. C.  
3417 Gordon C., Wenham  
3447 Hampshire C., Amherst  
3500 Harvard-Radcliffe Trans. Adm.,  
Cambridge

**Undergraduate Division:**  
3458 — Extension Sch.  
3434 — Harvard-Radcliffe,  
Cambridge  
**Graduate Schools:**  
3451 — Arts & Sciences  
3444 — Business Administration  
3427 — Business (Ph.D. prog. only)  
3502 — Chemistry & Chemical  
Biology  
— Dental Medicine  
3455 — Design  
3433 — Divinity  
3428 — Educ.  
3458 — Extension Sch. (Grad.  
progs.)

**(Massachusetts cont.)**

3478 — GSAS (Special Students  
Prog.)  
3457 — Law Sch.  
**J. F. Kennedy-Government:**  
3454 — 1 and 2-Year Programs  
9174 — 1-Year Mason Program  
(Mason only)  
3411 — Intl. Tax Prog.  
3450 — Med. Sci., Medical School  
3400 — Molecular and Cellular  
Biology Prog.  
3456 — Public Health  
9461 Harvard-Yenching Inst.,  
Cambridge  
3492 IASPAA: Academic and Prof.  
Prog. for the Americas  
3483 Lesley C., Cambridge  
3467 Longy Sch. of Music,  
Cambridge  
9229 MA Board of Registration in  
Nursing, Boston

3516 MA C. of Art, Boston  
3521 MA C. of Liberal Arts  
3512 MA C. of Pharmacy & Allied  
Health Sciences, both  
campuses, Boston  
3513 MA General Hosp. Allied Health,  
Boston  
3514 MA Inst. of Tech., Cambridge  
3504 MA Inst. of Tech., Cntr. for Real  
Estate, Cambridge  
3507 MA Inst. of Tech. Mgmt. of  
Tech. Prog., Cambridge  
3536 MA Inst. of Tech.,  
Sloan Fellows Prg., Cambridge  
3525 Merrimack C., N. Andover  
3529 Mt. Holyoke C., South Hadley  
3530 Mt. Ida C., Newton  
3639 Newbury C., Brookline  
3659 New England Conservatory of  
Music, Boston

**Northeastern U., Boston:**  
3667 — Undergraduate Only  
Graduate Schools:  
3682 Arts & Sciences  
3629 Bouve C. of Pharmacy & Health  
Sciences  
3667 Business Administration  
3679 Computer Sciences  
3680 Criminal Justice  
3665 Engineering  
3658 Law  
8011 Northfield Mt. Herman Sch.,  
Northfield

3651 North Shore Cmty. C., Danvers  
3689 Pine Manor C., Chestnut Hill  
3713 Quincy C., Quincy  
3723 Regis College, Weston  
3522 Salem St. C.  
3794 Sch. of the Museum of Fine Art,  
Boston  
3761 Simmons C., Boston  
3762 Smith C., Northampton  
3763 Springfield C.  
3770 Stonehill C., North Easton  
3771 Suffolk U., Boston  
3902 Tufts U., Boston, Sch. Dental  
Med.

3889 Tufts U., Boston, Sch. of  
Medicine  
**Tufts U., Medford:**  
3901 — Fletcher Sch. of Law &  
Diplomacy  
3891 — Sackler Sch. of Biomedical  
Sciences  
3917 U. of MA, Amherst  
3924 U. of MA, Boston  
3786 U. of MA, Dartmouth  
3911 U. of MA, Lowell  
3936 U. of MA, Med. Sch., Worcester  
3957 Wellesley C.  
3958 Wentworth Inst. Tech., Boston  
3962 Western New England C.,  
Springfield

3963 Wheaton C., Norton  
8009 Wilbraham and Monson Acad.  
3965 Williams C., Williamstown  
8018 Worcester Academy  
3969 Worcester Polytechnic Inst.  
3524 Worcester St. C.

**MICHIGAN (MI)**

1001 Adrian C.  
1007 Albion C.  
1030 Andrews U., Berrien Springs  
1095 Calvin C., Grand Rapids  
1096 Calvin Theological Seminary,  
Grand Rapids  
1106 Central MI U., Mt. Pleasant  
1156 Cranbrook Acad. Art, Bloomfield  
Hills  
1201 Eastern MI U., Ypsilanti  
1222 Ferris St. U., Big Rapids  
1743 Finlandia U., Hancock  
1254 Grand Rapids Jr. C., Grand  
Rapids  
1258 Grand Valley St. U., Allendale  
1365 Kalamazoo C.  
1246 Kettering U., Flint  
1414 Lansing Comm. C.  
1399 Lawrence Tech. U., Southfield  
1437 Madonna U., Livonia  
9228 MI Board of Nursing, Lansing  
9715 MI Board of Physical Therapy,  
Lansing

1465 MI St. U., East Lansing  
1464 MI Tech. U., Houghton  
Northern MI U., Marquette

**(Michigan cont.)**

1564 Northwestern MI C.,  
Traverse City  
1568 Northwood U., Midland  
1607 Oakland Cmty. C., Farmington  
Hills  
1497 Oakland U., Rochester  
1766 Saginaw Valley State U., U. Ctr.  
9877 Terra Temp. LTD.,  
Farmington Hills  
1835 U. of Detroit, Mercy  
1839 **U. of MI, Ann Arbor:**  
9585 — MBA Program  
1861 U. of MI, Dearborn  
1894 Walsh C., Troy  
1935 Washtenaw Comm. C.,  
Ann Arbor  
1898 Wayne St. U., Detroit  
1902 Western MI U., Kalamazoo  
1167 William Tyndale C.,  
Farmington Hills

**MINNESOTA (MN)**

6676 Bemidji State U., Bemidji  
6081 Carleton C., Northfield  
6104 C. of St. Benedict, St. Joseph  
6105 C. of St. Catherine, St. Paul  
6113 Concordia C., Moorhead  
6114 Concordia U., St. Paul  
6253 Gustavus Adolphus C., St. Peter  
6265 Hamline U., St. Paul  
6390 Macalester C., St. Paul  
6435 Martin Luther C., New Ulm  
6444 Mayo Grad. Sch. of Med.,  
Rochester  
6445 Metropolitan State U.,  
Minneapolis  
6434 Minneapolis Comm. & Tech. C.  
6677 Minnesota St. U., Mankato  
6678 Moorhead St. U.  
6501 Normandale Comm. C.  
6498 North Hennepin Comm. C.,  
Brooklyn Park  
6679 St. Cloud St. U.  
6624 St. John's U., Collegeville  
6632 St. Mary's U. of MN, Winona  
6638 St. Olaf C., Northfield  
6703 Southwest St. U., Marshall  
6873 U. of MN, Duluth  
6946 U. of MN, Minneapolis, C. of  
Pharmacy  
6874 U. of MN, Minneapolis/St. Paul  
6110 U. of St. Thomas, St. Paul  
6680 Winona St. U.

**MISSISSIPPI (MS)**

1341 Jackson St. U.  
1471 Millsaps College, Jackson  
9287 MIS St. Board of Nursing,  
Jackson  
9859 MIS St. Dept. of Health Prof.,  
Jackson  
1480 MIS St. U., MS St.  
1481 MS U. for Women, Columbus  
1857 U. of MS, Med. Center, Jackson  
1840 U. of MS, University  
1479 U. of Southern MS, Hattiesburg

**MISSOURI (MO)**

6109 Avila C., Kansas City  
6089 Central Methodist C., Fayette  
6090 Central MO St. U., Warrensburg  
6169 Drury U., Springfield  
6216 Fontbonne C., St. Louis  
6367 Lindenwood U., St. Charles  
6399 Maryville U., St. Louis  
9889 MO Board of Healing Arts,  
Jefferson City  
9258 MO St. Board of Nursing,  
Jefferson City  
6625 MO Western St. C., St. Joseph  
6488 Northwest MO St. U., Maryville  
6574 Park C., Parkville  
6611 Rockhurst C., Kansas City  
6627 St. Louis Conservatory  
of Music,  
St. Louis U.  
6655 Southeast MO St. U.,  
Cape Girardeau  
6665 Southwest MO St. U.,  
Springfield  
6483 Truman St. U., Kirksville  
6875 U. of MO, Columbia  
6872 U. of MO, Kansas City  
6876 U. of MO, Rolla  
6889 U. of MO, St. Louis  
6929 Washington U., St. Louis  
6933 Webster U., St. Louis

**MONTANA (MT)**

4041 Carroll C., Helena  
4488 MT St. U., Bozeman  
4487 MT Tech. of U. MT, Butte  
4489 U. of MT, Missoula

**NEBRASKA (NE)**

6053 Bellevue U., Bellevue  
6121 Creighton U., Omaha  
6165 Doane C., Crete  
6248 Grace U., Omaha  
6467 U. of NE, Kearney  
6877 U. of NE, Lincoln  
6420 **U. of NE, Omaha:**  
6947 — Japanese Studies Exch.  
Prog.  
6896 — Med. Ctr.

**NEVADA (NV)**

4136 Comm. C. Southern NV.,  
N. Las Vegas

**(Nevada cont.)**

- 4960 Truckee Meadows Comm. C., Reno
- 4861 U. of NV, Las Vegas
- 4844 U. of NV, Reno
- 4972 Western NV Comm. C., Carson City

**NEW HAMPSHIRE (NH)**

- 8008 Brewster Academy, Wolfeboro
- 3396 Franklin Pierce Law Center
- 3351 Dartmouth C., Hanover
- 3649 NH C., Manchester
- 3690 Plymouth St. C.
- 3728 Rivier C., Nashua
- 3748 St. Anselm C., Manchester
- 3918 U. of NH, Durham

**NEW JERSEY (NJ)**

- 2061 Berkeley C. of Business, Little Falls
- 2080 Centenary C., Hackettstown
- 2519 C. of New Jersey, Trenton
- 2090 C. of St. Elizabeth, Convent Station
- 2193 Drew U., Madison
- 2262 Fairleigh Dickinson U., Madison
- 2263 Fairleigh Dickinson U., Teaneck
- 2516 Jersey City St. C.
- 2517 Kean U., Union
- 2444 Mercer County C.C., Trenton
- 2441 Middlesex County C., Edison
- 2416 Monmouth U., W. Long Branch
- 2512 Montclair St. U.
- 2513 NJ Inst. of Tech., Newark
- 9380 NJ St. Board of Nursing, Newark
- 9359 NJ St. Board of Pharmacy, Newark
- 9663 NJ St. Board of Physical Therapy, Newark
- 9503 NJ St. Board of Prof. Engineers & Land Surveyors, Newark
- 2671 Princeton Theological Seminary
- 2672 Princeton U.
- 2884 Ramapo C. of NJ, Mahwah
- 2889 Richard Stockton C. of NJ, Pomona
- 2758 Rider U., Lawrenceville
- 2515 Rowan U., Glassboro

**Rutgers - The St. U.:**

- 2092 — Camden C. of Arts & Sci.
- 2838 — C. of Engineering, New Brunswick
- 2789 — C. of Nursing, Newark
- 2839 — C. of Pharmacy, New Brunswick
- 2170 — Cook C., New Brunswick
- 2192 — Douglass C., New Brunswick
- 2384 — Livingston C., New Brunswick
- 2736 — Mason Gross Sch. of the Arts, New Brunswick
- 2512 — Newark C. of Arts & Sci., Rutgers C., New Brunswick

**University Colleges:**

- 2742 — Camden
- 2777 — New Brunswick
- 2753 — Newark

**Graduate & Professional Schools:**

- 2092 — Camden
- 2790 — New Brunswick
- 2512 — Newark
- 2725 — Ph.D. in Mgt., Newark
- 2783 — Sch. Mgt. & Labor Relations
- 9207 St. Barnabas Med. Ctr., Livingston
- 2858 St. Francis Med. Center Sch. of Nursing, Trenton
- 9205 St. Michael's Med. Center, Newark
- 2806 St. Peter's C., Jersey City
- 2811 Seton Hall U., South Orange
- 2819 Stevens Inst. of Tech., Hoboken
- 7460 Student Aid Intl., Fanwood
- 2578 U. of Med. & Dentistry, Newark
- 2895 — Health Professions
- 2786 U. of Med. & Dentistry Bio-Med. Sci., Piscataway
- 2974 Westminster Choir C. of Rider U., Princeton
- 2518 William Paterson U., Wayne

**NEW MEXICO (NM)**

- 4299 Eastern NM U., Portales
- 4532 NM Highlands U., Las Vegas
- 4533 NM Inst. of Mining Tech., Socorro
- 4531 NM St. U., Las Cruces
- 4845 U. of NM, Albuquerque

**NEW YORK (NY)**

- 2003 Adelphi U., Garden City
- 2151 African American Inst. (AFGRAD), New York
- 2013 Albany C. of Pharmacy
- 2947 Albany Med. C.
- 2005 Alfred U.
- 2157 Audrey Cohen C.
- 2035 Bank Street C. of Edu, New York
- 2037 Bard C., Annandale-on-Hudson
- 2038 Barnard C., New York
- 2048 Broome Comm. C., Binghamton

**(New York cont.)**

- 2073 Canisius C., Buffalo
- City U. of New York:**
- 2950 **All undergraduate schools. Students applying to graduate divisions use:**
- 2034 — Baruch C.
- 2046 — Brooklyn C.
- 2083 — City C. of New York
- 2778 — C. of Staten Island
- 2113 — Grad. Center
- 2312 — Herbert H. Lehman C.
- 2301 — Hunter C.:
- 2308 — Sch. of Social Work
- 2750 — Queens C.
- 2992 — York C.
- 2084 Clarkson U., Potsdam
- 2086 Colgate U., Hamilton
- 2001 C. of Aeronautics, Flushing
- 2112 C. of Insurance, New York
- 2088 C. of Mt. St. Vincent, Riverdale
- 2089 C. of New Rochelle
- 2091 C. of St. Rose, Albany

**Columbia U.:**

- 2141 — Business Sch. Doctoral (Ph.D.)
- 2116 — Columbia C.
- 2162 — Grad. Sch. of Arts & Sci.
- 2619 — Grad. Sch. of Arts & Sciences at Physicians/Surgeons
- 2173 — Human Nutrition Prog.
- 2137 — Physical Therapy & Occupational Therapy
- 2164 — Sch. of Architecture
- 2174 — Sch. of Business/MBA
- 2594 — Sch. of Continuing Educ.
- 2094 — Sch. of Dental & Oral Surgery
- 2111 — Sch. of Engineering & Applied Sciences
- 2095 — Sch. of General Studies
- 2161 — Sch. of Intl. Affairs
- 2120 — Sch. of Journalism
- 2163 — Sch. of Law
- 2159 — Sch. of Public Health & Administrative Medicine
- 2158 — Sch. of Social Work
- 2171 — Sch. of the Arts
- 2905 — Teachers C.
- 2096 Concordia C., Bronxville
- 9970 Consortium for Acad. Prtnsp., New York
- 2097 Cooper Union, New York
- 2098 **Cornell U., Ithaca:**
- 2114 — Master of Mgmt. in Hospitality
- 2119 — Med. Sciences, New York
- 2011 Dowling C., Oakdale
- 2226 Elmira C.
- 2228 Erie Comm. C., North Williamsville
- 2257 Fashion Inst. of Tech., New York

**Fordham U., New York:**

- 2264 — LLM Prog.
- 2286 Hamilton C., Clinton
- 2294 Hobart C., Geneva
- 2295 Hofstra U., Hempstead
- 2300 Hudson Valley Comm. C., Troy
- 2326 Inst. Intl. Educ., New York
- 2324 Iona C., New Rochelle
- 2325 Ithaca C., Ithaca
- 2340 Juilliard Sch., New York
- 9940 Kaplan Educ. Center Ltd., New York

**Kosciuszko Fdn., New York**

- 2246 LA Guardia Comm. C., New York
- 2595 Lebanese American U., New York
- 2366 Le Moyne C., Syracuse
- 2369 Long Island U., Brooklyn
- 2070 Long Island U., C. W. Post Center, Brookville
- 2395 Manhattan C., Riverdale
- 2396 Manhattan Sch. of Music, New York
- 2397 Manhattanville C., Purchase
- 2398 Mannes C. of Music, New York
- 2400 Marist C., Poughkeepsie
- 2406 Marymount C., Tarrytown
- 2405 Marymount Manhattan C., New York
- 2429 Monroe Comm. C., Rochester
- 2464 Mt. Sinai Sch. of Medicine, New York
- 2563 Nassau Comm. C., Garden City

**New Sch. for Social Research, New York:**

- 2572 — B.A. Degree Prog.
- 2521 — Eugene Lang C.
- 2638 — Parsons Sch. of Design

**Graduate Schools:**

- 2554 — Library Science/Media Studies
- 2529 — Management & Urban Prof.
- 2638 — Parsons Sch. of Design
- 2501 — Political & Social Sciences
- 2553 — Grad. Sch. Basic Med. Sci.
- 2592 — Grad. Sch. Health Science
- 2486 NY Coll. Osteopathic Med., Old Westbury
- 2561 NY Inst. of Tech., Old Westbury
- 9185 NY Sch. Interior Design, New York

**New York U., New York:**

- 2562 **Undergraduate Schools**
- Graduate Schools:**
- 2596 — Arts & Sciences

**(New York cont.)**

- 2503 — Basic Med. Sciences
- 2559 — Dentistry, Tourism & Travel
- 2597 — Hospitality
- 2569 — Gallatin Division
- 2599 — Law:
- 9306 — Inter-American/Comparative Law Insts.
- 2504 — Manhattanville C.
- 2583 — Master of Science in Publishing
- 2581 — Med. Sch.
- 2507 — Public Administration
- 2557 — Sch. of Continuing Educ.
- 2556 — Sch. of Educ.
- 2506 — Social Work
- 2582 — Stern Sch. Business/MBA
- 2586 — Stern Sch. Business/PHD
- 9633 — Tisch Sch. of Arts
- 2558 — Niagara U.
- 2635 Pace U., New York
- 2685 Pace U., Pleasantville
- 2644 Pace U., White Plains
- 2638 Parsons Sch. of Design, New York

- 0594 Phelps-Stokes Fund, New York
- 2668 Poly. U. of New York, Brooklyn
- 2681 Population Council, New York
- 2669 Pratt Inst., Brooklyn
- 8117 Rensselaer Poly. Inst., Troy
- 2757 Rochester Inst. of Tech.
- 9413 Rockefeller Fdn., New York
- 2761 Rockefeller U., New York
- 2799 St. John's U., Jamaica
- 2805 St. Lawrence U., Canton
- 2810 Sarah Lawrence C., Bronxville
- 2835 Sch. of Visual Arts, New York
- 2815 Skidmore C., Saratoga Springs
- 9914 Soros Fdn.-Belarus, New York
- 9717 Soros Fdn.-Hungary, New York
- 9868 Soros Fdn.-Latvia, New York
- 1526 Soros Fdn.-Lithuania, New York

**St. U. of NY:**

- 2527 — Agric. Tech. C., Morrisville
- 2533 — Buffalo St. C.
- 2532 — Center at Albany (U.)
- 2535 — Center at Binghamton (U.)
- 2925 — Center at Buffalo (U.)
- 2548 — Center at Stony Brook (U.):
- 2891 — Health Science Center
- 2537 — C. at Brockport
- 2533 — C. at Buffalo (1300 Elmwood)
- 2739 — C. at Buffalo (Roswell Park)
- 2538 — C. at Cortland
- 2539 — C. at Fredonia
- 2540 — C. at Genesee
- 2541 — C. at New Paltz
- 2864 — C. at Old Westbury
- 2542 — C. at Oneonta
- 2543 — C. at Oswego
- 2544 — C. at Plattsburg
- 2545 — C. at Potsdam
- 2878 — C. at Purchase
- 2524 — C. of Agric./Tech., Cobleskill
- 2530 — C. of Environmental Science/Forestry, Syracuse
- 2522 — C. of Tech., Alfred
- 2523 — C. of Tech., Canton
- 2525 — C. of Tech., Delhi
- 2526 — C. of Tech., Farmingdale
- 2214 — Empire St. C., Saratoga Springs
- 2547 — Health Sci. Center, Brooklyn
- 2534 — Health Sci. Ctr., Syracuse
- 2896 — Inst. Tech., Utica/Rome
- 2536 — Maritime C., Bronx
- 2827 Suffolk Cnty. Cmty. C., Selden
- 2823 Syracuse U.
- 2902 Touro C., New York City
- 2920 Union C. & U., Schenectady
- 2924 U.S. Military Acad., West Point

**U. of Rochester:**

- 2224 — Eastman Sch. Music
- 2948 — Sch. Medicine & Dentistry
- 2956 Vassar C., Poughkeepsie
- 2966 Wagner C., Staten Island
- 2971 Wells C., Aurora
- 2972 Westchester Comm. C., Valhalla
- 2978 William C. Smith C., Geneva
- 2990 **Yeshiva U., New York:**
- 2997 — Albert Einstein C. of Medicine

**NORTH CAROLINA (NC)**

- 5010 Appalachian St. U., Boone
- 5055 Belmont Abbey C., Belmont
- 5100 Campbell U., Buies Creek
- 5102 Central Piedmont Comm. C., Charlotte
- 5107 Chowan C., Murrfreesboro
- 5150 Davidson C.
- 5156 Duke U., Durham
- 5180 East Carolina U., Greenville
- 5183 Elon C.
- 5261 Guilford C., Greensboro
- 5365 Lenoir Rhyne C., Hickory
- 5410 Meredith C., Raleigh
- 5003 NC Agric. & Tech. St. U., Greensboro
- 9688 NC Board of Physical Therapy Examiners, Durham
- 5495 NC Central U., Durham
- 5512 NC Sch. Arts, Winston-Salem
- 5496 NC St. U., Raleigh
- 5214 St. Andrews Presbyterian C., Laurinburg

**(North Carolina cont.)**

- 5013 U. of NC, Asheville
- 5816 U. of NC, Chapel Hill
- 5105 U. of NC, Charlotte
- 5913 U. of NC, Greensboro
- 5907 U. of NC, Wilmington
- 5885 Wake Forest U., Winston - Salem
- 5928 Wake Technical Comm. C., Raleigh
- 5886 Warren Wilson C., Asheville
- 5897 Western Carolina U., Cullowhee
- 5908 Wingate U.

**NORTH DAKOTA (ND)**

- 6477 Dickinson St. U.
- 6479 Minot St. U.
- 6474 ND St. U., Fargo
- 6878 U. of ND, Grand Forks

**OHIO (OH)**

- 1021 Ashland U.
- 1050 Baldwin-Wallace C., Berea
- 1069 Bowling Green St. U.
- 1110 Capital U. Law & Grad. Center
- 1105 Case Western Reserve U., Cleveland
- 1984 Cincinnati St. Tech. Comm. C.
- 1124 Cleveland Inst. Music
- 1221 Cleveland St. U.
- 1134 C. of Wooster
- 1164 Columbus St. Comm. C.
- 1154 Denison U., Granville
- 1129 Franklin U., Columbus
- 1292 Heidelberg C., Tiffin
- 1342 John Carroll U., University Hts.
- 1367 Kent St. U.
- 1370 Kenyon C., Gambier
- 1542 Medical C. of OH, Toledo
- 1463 Miami U., Oxford
- 1496 Muskingum C., New Concord
- 1566 Notre Dame C. of Ohio, Cleveland
- 1587 Oberlin C.
- 9290 OH Board of Nursing Educ. & Registry, Columbus
- 1591 OH Northern U., Ada
- 9693 OH St. Board of Pharmacy, Columbus
- 9636 OH St. Medical Board, Columbus
- 1592 OH St. U., Columbus
- 1593 OH U., Athens
- 1594 OH Wesleyan U., Delaware
- 1597 Otterbein C., Westerville
- 1829 U. of Akron
- 1833 U. of Cincinnati
- 1834 U. of Dayton
- 1223 U. of Findlay
- 1845 U. of Toledo
- 1909 Wilmington C.
- 1922 Wittenberg U., Springfield
- 1179 Wright St. U., Dayton
- 1965 Xavier U., Cincinnati
- 1975 Youngstown St. U.

**OKLAHOMA (OK)**

- 6080 Cameron U., Lawton
- 9874 Maxwell Healthcare, Inc., Tulsa
- 6485 Northeastern St. U., Tahlequah
- 6493 Northwestern OK St. U., Alva
- 6541 OK Baptist U., Shawnee
- 6543 OK City U.
- 6571 OK Panhandle St. U., Goodwell
- 6546 OK St. U., Stillwater
- 6552 Oral Roberts U., Tulsa
- 6545 Rogers St. U., Claremore
- 6559 Rose St. C., Midwest City
- 6657 Southeastern OK St. U., Durant
- 6673 Southwestern OK St. U. WFD
- 6091 U. of Central OK, Edmond
- 6879 U. of OK, Norman
- 6902 U. of OK, Health Sciences Center, Oklahoma City
- 6883 U. of Tulsa

**OREGON (OR)**

- 4231 Art Inst., Portland
- 4093 Cascade C., Portland
- 4745 Chemeketa Comm. C., Salem
- 4300 Eastern OR St. C., La Grande
- 4407 Lane Comm. C., Eugene
- 4384 Lewis and Clark C., Portland
- 4387 Linfield C., McMinnville
- 4413 Linn-Benton Comm. C., Albany
- 4592 OR Grad. Inst. Science & Tech., Beaverton

**OR Health Science U., Portland:**

- 4871 — Dental Sch.
- 4865 — Medical Sch.
- 4587 OR Inst. of Tech., Klamath Falls
- 4586 OR St. U., Corvallis
- 4601 Pacific U., Forest Grove
- 8066 Portland Christian H.S.
- 4617 Portland Comm. C.
- 4610 Portland St. U.
- 4654 Reed C., Portland
- 4702 Southern OR U., Ashland
- 4825 Treasure Valley Comm. C., Ontario

**U. of Pittsburgh, Pittsburgh:**

- 4846 U. of OR, Eugene
- 7856 U. of Phoenix, OR
- 4847 U. of Portland
- 4595 Warner Pacific C., Portland
- 4944 Western Evangelical Seminary, Portland
- 4585 Western OR U., Monmouth

**(Oregon cont.)**

- 4968 Western Seminary, Portland
- 4954 Willamette U., Salem

**PENNSYLVANIA (PA)**

- 2004 Albright C., Reading
- 2006 Allegheny C., Meadville
- 2021 Allentown C. St. Francis De Sales, Center Valley
- 2033 Art Institute of Philadelphia
- 2039 Beaver C., Glenside
- 2656 Bloomsburg U. of PA
- 2002 Bryn Athyn C.
- 2049 Bryn Mawr C.
- 2050 Bucknell U., Lewisburg
- 2647 California U. of PA
- 2074 Carnegie Mellon U., Pittsburgh
- 2649 Clarion U. of PA
- 9988 Commn. on Grad. of Foreign Nursing Sch. (CGFNS), Philadelphia
- 2100 Curtis Inst. Music, Philadelphia
- 2186 Dickinson C., Carlisle
- 2187 Dickinson Sch. of Law, Carlisle
- 2204 Drexel U., C. of Business, Philadelphia
- 2194 Drexel U., Philadelphia
- 2196 Duquesne U., Pittsburgh
- 2650 East Stroudsburg U. of PA
- 2220 Eastern C., St. Davids
- 2851 Edinboro U. of PA
- 9108 Educ. Commn. for Foreign Med. Grad. Physicians (ECFMG), Philadelphia
- 2225 Elizabethtown C.
- 2261 Franklin & Marshall C., Lancaster
- 2270 Gannon U., Erie
- 2275 Gettysburg C.
- 2277 Grove City C.
- 1463 Harcum C., Bryn Mawr
- 2289 Haverford C.
- 2652 Indiana U. of PA
- 9988 Intl. Commn. on Healthcare Prof. (IChP), Philadelphia
- 2341 Juniata C., Huntingdon
- 2351 Keystone C., LaPlume
- 2353 Kings C., Wilkes Barre
- 2653 Kutztown U. of PA
- 2363 La Salle U., Philadelphia
- 2361 Lafayette C., Easton
- 2365 Lehigh U., Bethlehem
- 2367 Lincoln U. of the Commonwealth of PA
- 2654 Lock Haven U. of PA
- 2280 Manor C., Jenkintown
- 2655 Mansfield U. of PA
- 2407 Marywood U., Scranton

**MCP Hahnemann U., Philadelphia:**

- Undergraduate:**
- 2306 — Sch. of Health Professions
- Graduate:**
- 2980 — Biomedical Sci., Grad. Progs.
- 2285 — Health Prof. & Clinical Psychology, Grad. Progs.
- Sch. of Public Health
- 2426 Messiah C., Grantham
- 2411 Millersville U. of PA
- 2417 Moore C. of Art and Design, Philadelphia
- 2418 Moravian C., Bethlehem
- 2424 Muhlenberg C., Allentown
- 9691 PA St. Board of Med. Educ. & Licensing, Harrisburg
- 2708 PA St. U., Middletown
- 2660 PA St. U., University Park
- 2661 Philadelphia C. of Bible
- 2666 Philadelphia U.
- 2676 Point Park C., Pittsburgh
- 2743 Reading Area Comm. C., Reading
- 2801 St. Joseph's U., Philadelphia
- 2812 Seton Hill C., Greenburg
- 2657 Shippensburg U. of PA
- 2658 Slippery Rock U. of PA
- 2820 Susquehanna U., Selinsgrove
- 2821 Swarthmore C.
- 2906 — Temple U., Philadelphia:
- 2907 — C. of Engineering
- 2208 — Department of Chemistry
- 2752 — Inst. of Global Mgt. Studies
- 2826 — Sch. of Dentistry
- 2999 Thomas Jefferson U. Grad. Studies, Philadelphia

**U. of PA, Philadelphia:**

- 2926 — Annenberg School
- 2900 — Bio-med. Studies (Grad.)
- 2944 — Dental Medicine
- 2888 — Engineering Applied Sci.
- 2943 — Grad. Sch. of Education
- 2984 — Grad. Sch. of Fine Arts
- 2953 — Lauder Inst.
- 2954 — Wharton Doctoral Prog.
- 2927 **U. of Pittsburgh, Pittsburgh:**
- 2987 — Health Administration (Grad. only)
- 2998 — Katz Sch. PhD Prog.
- 2574 — Public & Intl. Affairs
- 2929 U. of Scranton
- 2664 U. of the Arts, Philadelphia
- 2663 U. of the Sciences, Philadelphia
- 2931 Ursinus C., Collegeville
- 2955 Valley Forge Military C., Wayne
- 2959 Villanova U.
- 2659 West Chester U. of PA
- 9070 Western Sch. of Health and Business Careers
- Westminster Theological Seminary, Philadelphia

**(Pennsylvania cont.)**

- 2642 Widener U., Chester
  - 2977 Wilkes U., Wilkes-Barre
  - 2991 York C. of PA
- RHODE ISLAND (RI)**
- 3094 Brown U., Providence
  - 3095 Bryant C., Smithfield
  - 3733 C.C.R.I., Warwick/Lincoln
  - 3465 Johnson & Wales U., Providence
  - 3693 Providence C.
  - 3724 RI C., Providence
  - 3726 RI Sch. of Design, Providence
  - 3729 Roger Williams U., Bristol
  - 3759 Salve Regina U., Newport
  - 3919 U. of RI, Kingston

**SOUTH CAROLINA (SC)**

- 5065 Bob Jones U., Greenville
- 5079 Charleston Southern U.
- 5111 Clemson U.
- 5837 Coastal Carolina U., Conway
- 5113 C. of Charleston
- 5117 Columbia C., Columbia
- 5116 Columbia Intl. U.
- 5222 Furman U., Greenville
- 5305 Horry Georgetown Tech., C., Conway
- 5407 Medical U. of SC, Charleston
- 5584 Midlands Tech. C., Columbia
- 9561 SC St. Board Therapy Exam., Columbia
- 5627 Spartanburg Methodist C., Spartanburg
- 5818 U. of SC, Columbia
- 5910 Winthrop U., Rock Hill
- 5912 Wofford C., Spartanburg

**SOUTH DAKOTA (SD)**

- 6247 Dakota State U., Madison
- 6279 Huron U.
- 6652 SD Sch. of Mines & Tech., Rapid City
- 6653 SD St. U., Brookings
- 6651 U. of Sioux Falls
- 6881 U. of SD, Vermillion

**TENNESSEE (TN)**

- 1028 Austin Peay St. U., Clarksville
- 1058 Belmont U., Nashville
- 1102 Carson-Newman C., Jefferson City
- 1121 Christian Brothers U., Memphis
- 1198 East TN St. U., Johnson City
- 1230 Freed-Hardeman U., Henderson
- 1394 Lambuth U., Jackson
- 1466 Middle TN St. U., Murfreesboro
- 1730 Rhodes C., Memphis
- 9956 TN Comm. Physical Therapy, Nashville
- 1803 TN St. U., Nashville
- 1804 TN Tech. U., Cookeville
- 1818 TN Temple U., Chattanooga
- 1809 Trevecca Nazarene U., Nashville
- 1826 Union U., Jackson
- 1459 U. of Memphis
- 1831 U. of TN, Chattanooga
- 1843 U. of TN, Knoxville
- 1844 U. of TN, Martin
- 1850 U. of TN, Memphis, Health Sci. Ctr.
- 1887 U. of TN, Tullahoma
- 1842 U. of the South, Sewanee
- 1871 Vanderbilt U., Nashville

**TEXAS (TX)**

- 6001 Abilene Christian U.
- 6644 Angelo St. U., San Angelo
- 9405 Arabian-American Oil Co. (ARAMCO), Houston
- 6016 Austin C., Sherman
- 6759 Austin Comm. C.
- 6059 Baylor C. of Dentistry, Dallas
- 6052 Baylor C. of Medicine, Houston
- 6032 Baylor U., Waco
- 6043 Blinn C., Brenham
- 6070 Brookhaven C., Farmers Branch
- 6055 Coastal Bend C., Beeville
- 6144 Criswell C., Dallas
- 6159 Dallas Baptist U.
- 6156 Dallas Theological Seminary
- 6268 Hardin-Simmons U., Abilene
- 9683 Health Care Intl., Houston
- 9684 Health Focus, Wharton
- 9876 Healthcare Staff Resources, Inc., Carrollton
- 6282 Houston Baptist U.
- 6296 Houston Comm. C.
- 6278 Howard Payne U., Brownwood
- 6360 Lamar U., Beaumont
- 6408 Midwestern St. U., Wichita Falls
- 6465 Navarro C., Corsicana
- 6550 Our Lady of the Lake U. of San Antonio
- 6580 Prairie View A&M U.
- 6609 Rice U., Houston
- 6607 Richland C., Dallas
- 6619 St. Edward's U., Austin
- 6637 St. Mary's U., San Antonio
- 6834 Tarrantnty. Jr. C., Fort Worth
- 6643 Sam Houston St. U., Huntsville
- 6647 Schreiner C., Kerrville
- 6660 Southern Methodist U., Dallas
- 6667 Southwest TX St. U., San Marcos
- 6668 Southwestern Baptist Theological Seminary, Ft. Worth
- 9879 Southwestern General Hospital, El Paso

**(Texas cont.)**

- 6674 Southwestern U., Georgetown
- 6682 Stephen F. Austin St. U., Nacogdoches
- 6685 Sul Ross St. U., Alpine
- 6817 Tarleton St. U., Stephenville
- 6838 TX A&M Intl. U., Laredo
- 6003 TX A&M U., College Station
- 6188 TX A&M U., Commerce
- 6849 TX A&M U., Corpus Christi
- 6822 TX A&M U., Kingsville
- 9286 TX Board of Nurse Examiners, Austin
- 6820 TX Christian U., Fort Worth
- 3595 TX Intl. Educ. Consortium, Austin
- 6824 TX Southern U., Houston
- 6851 TX Tech. U., Health Sci. Ctr.
- 6827 TX Tech. U., Lubbock
- 6826 TX Woman's U., Denton
- 6831 Trinity U., San Antonio
- 6868 U. of Dallas, Irving
- 6916 U. of Houston, Clear Lake City
- 6922 U. of Houston, Downtown C.
- 6870 U. of Houston, University Park
- 6917 U. of Houston, Victoria
- 6481 U. of North TX, Denton
- 6880 U. of St. Thomas, Houston
- 6013 U. of TX - Arlington
- 6882 U. of TX - Austin
- 6897 U. of TX - Dallas, Richardson
- 6886 U. of TX - Dallas, SW Med. Ctr.
- 6829 U. of TX - El Paso
- 6887 U. of TX - Galveston, Med. Branch
- 6907 U. of TX - Houston, Biomedical Sciences
- 6906 U. of TX - Houston, Health Sci. Ctr., Sch. of Public Health
- 6570 U. of TX - Pan American, Edinburg
- 6919 U. of TX - San Antonio: — Health Science Center (Grad. Biomedical Sciences)
- 6908 U. of TX - Tyler
- 6850 U. of The Incarnate Word, San Antonio
- 6938 West TX A&M U., Canyon

**UTAH (UT)**

- 4019 Brigham Young U., Provo
- 4283 Dixie C., St. George
- 4864 Salt Lake Comm. C.
- 4092 Southern Utah U., Cedar City
- 4853 U. of UT, Salt Lake City
- 4857 UT St. U., Logan
- 4870 Utah Valley State C., Orem
- 4941 Weber St. U., Ogden

**VERMONT (VT)**

- 3080 Bennington C.
- 3291 Champlain C., Burlington
- 3526 Middlebury C.
- 3757 St. Michael's C., Colchester
- 3788 School for Intl. Training, Brattleboro
- 3920 U. of VT, Burlington

**VIRGINIA (VA)**

- 5017 Averett C., Danville
- 7048 Averett C., Vienna
- 5128 Christopher Newport U., Newport News
- 5115 C. of William & Mary in VA, Williamsburg
- 5827 George Mason U., Fairfax
- 5292 Hampton U.
- 5294 Hollins U., Roanoke
- 5392 James Madison U., Harrisonburg
- 6314 Keller Grad. Sch. of Mgmt. VA., McLean
- 5385 Liberty U., Lynchburg
- 5372 Lynchburg C.
- 5398 Mary Washington C., Fredericksburg
- 5405 Marymount U., Arlington
- 5864 Norfolk St. U.
- 5510 Northern VA Comm. C., Alexandria
- 5515 Northern VA Comm. C., Annandale
- 5774 Northern VA Comm. C., Manassas
- 5775 Northern VA Comm. C., Sterling
- 5517 Northern VA Comm. C., Woodbridge

- 5126 Old Dominion U., Norfolk
- 5565 Radford U.
- 5566 Randolph Macon C., Ashland
- 5567 Randolph Macon Womens C., Lynchburg
- 5135 Regent U., Virginia Beach
- 5613 Shenandoah U., Winchester
- 5634 Sweet Briar C.
- 5805 Union Theological Seminary, Richmond
- 5569 U. of Richmond
- 5820 U. of VA, Charlottesville
- 5836 U. of VA, C. Eng. Applied Science, Charlottesville
- 5570 VA Commonwealth U., Richmond (Includes Med. Campus)
- 5858 VA Military Inst., Lexington
- 5859 VA Poly. Inst. & St. U., Blacksburg
- 9291 VA St. Board of Nursing, Richmond

**(Virginia cont.)**

- 9938 VA St. Board of Pharmacy, Richmond
  - 5860 VA St. U., Petersburg
  - 5862 VA Union U., Richmond
  - 5887 Washington & Lee U., Lexington
- WASHINGTON, State of (WA)**
- 9839 Bastyr U., Seattle
  - 4029 Bellevue Comm. C.
  - 4024 Big Bend Comm. C., Moses Lake
  - 4044 Central WA U., Ellensburg
  - 4045 Centralia C.
  - 4042 City U., Bellevue
  - 4801 Cornish C. of the Arts, Seattle
  - 4301 Eastern WA U., Cheney
  - 4307 Edmonds Comm. C., Lynnwood
  - 4292 Evergreen St. C., Olympia
  - 4330 Gonzaga U., Spokane
  - 4337 Green River Comm. C., Auburn
  - 4344 Heritage C., Toppenish
  - 4348 Highline Comm. C., Des Moines
  - 4554 North Seattle C.C., Seattle
  - 4597 Pacific Lutheran U., Tacoma
  - 4615 Peninsula C.
  - 4741 Seattle Central Comm. C.
  - 4694 Seattle Pacific U., Seattle
  - 4738 Shoreline Comm. C., Seattle
  - 4759 South Seattle Comm. C., Seattle
  - 4739 Spokane Comm. C.
  - 4752 Spokane Falls Comm. C.
  - 4826 Tacoma Comm. C.
  - 0876 Trinity Western U., Blaine
  - 4067 U. of Puget Sound, Tacoma
  - 4854 U. of WA, Seattle
  - 4705 WA St. U., Pullman
  - 4947 Western WA U., Bellingham
  - 4951 Whitman C., Walla Walla
  - 4953 Whitworth C., Spokane
  - 4993 Yakima Valley Comm. C., Yakima
- WEST VIRGINIA (WV)**
- 5005 Alderson-Braddus C., Philippi
  - 5120 Concord C., Athens
  - 5151 Davis & Elkins C., Elkins
  - 5396 Marshall U., Huntington
  - 5901 West Liberty St. C.
  - 5902 WV U. Inst. of Tech., Montgomery
  - 5904 WV U., Morgantown
  - 5905 WV Wesleyan C., Buckhannon
- WISCONSIN (WI)**
- 1059 Beloit C.
  - 1101 Carroll C., Waukesha
  - 1103 Carthage C., Kenosha
  - 1172 Chippewa Valley Tech. C., Eau Claire
  - 1139 Concordia U., Mequon
  - 1202 Edgewood C., Madison
  - 1393 Lakeland C., Sheboygan
  - 1398 Lawrence U., Appleton
  - 1448 Marquette U., Milwaukee
  - 1519 Med. C. of WI, Milwaukee
  - 1476 Milwaukee Sch. of Engineering
  - 1706 St. Norbert C., DePere
  - 1913 U. of WI - Eau Claire
  - 1859 U. of WI - Green Bay
  - 1914 U. of WI - LaCrosse
  - 1846 U. of WI - Madison
  - 1473 U. of WI - Milwaukee
  - 1916 U. of WI - Oshkosh
  - 1860 U. of WI - Parkside
  - 1917 U. of WI - Platteville
  - 1918 U. of WI - River Falls
  - 1919 U. of WI - Stevens Point
  - 1740 U. of WI - Stout, Menomonie
  - 1920 U. of WI - Superior
  - 1921 U. of WI - Whitewater
  - 8028 Wayland Academy, Beaver Dam
  - 9861 WI Dept. of Regulation & Licensing, Madison

**WYOMING (WY)**

- 4542 Northwest C., Powell
- 4855 U. of WY, Laramie
- 4957 Western WY Comm. C., Rock Springs

**Agencies and Institutions in Canada**

**CANADA**

- 0901 Acadia U., Wolfville
- 9398 Alberta Assoc. of Registered Nurses, Edmonton
- 7004 Algonquin College, Rideau Campus, Ottawa
- 7005 Algonquin College, Nepean
- 0015 Alliance Physiotherapy Regional Board, Toronto
- 0105 Ashbury C., Ottawa
- 9140 Assoc. of Professional Engineers, Geologists, - Geophysicists of Alberta, Edmonton
- 9288 Assoc. of Registered Nurses of Newfoundland, St. John's
- 9716 Atlantic Baptist C., Moncton
- 0920 Augustana U. C., Camrose
- 0906 Bishops U., Lennoxville

**(Canada cont.)**

- 9078 Bow Valley C., Calgary
- 0905 Brandon U.
- 9543 British Columbia Council LPN, Burnaby
- 9110 British Columbia Inst. of Tech., Burnaby
- 0895 Brock U., St. Catherine's
- 9873 Canadian Association of Med. Radiation Tech., Ottawa
- 9500 Canadian Bureau Intl. Educ., Ottawa
- 0914 Canadian U.C., College Hts.
- 0505 Capilano C., Vancouver
- 0854 Carleton U., Ottawa
- 9213 Centennial C., Scarborough
- 9230 C. of Nurses of Ontario, Toronto
- 9681 C. of Physicians & Surgeons, Saskatoon
- 9544 C. of Physicians & Surgeons of Ontario, Toronto
- 0800 Columbia C., Burnaby
- 0916 Concordia U. Coll., Edmonton
- 0956 Concordia U., Montreal
- 0068 Coquitlam C.
- 0915 Dalhousie U., Halifax
- 0847 Dawson C., Montreal
- 0958 Douglas C., New Westminster
- 0032 Emily Carr C. of Art & Design, Vancouver
- 9375 George Brown C. of Applied Arts & Tech., Toronto
- 9395 Grande Prairie Regl. C.
- 0720 Grant MacEwan Comm. C., Edmonton
- 9285 Humber C., Ontario
- 9939 Intl. CNCL Canada STDS, Ontario
- 9558 Intl. Medical Grad. Prog., Toronto
- 0157 Kwantlen University C., Surrey
- 0888 Lakehead U., Thunder Bay
- 0335 Langara C., Vancouver
- 0889 Laurentian U., Sudbury
- 0930 Lethbridge Comm. C.
- 9289 Manitoba Assoc. of Registered Nurses, Winnipeg
- 0832 Marianopolis C., Montreal
- 0935 McGill U., Montreal: — Graduate Law Prg.
- 0936 McMaster U., Hamilton
- 9333 Medicine Hat C.
- 0885 Memorial U. of Newfoundland, St. John's
- 0939 Mt. Allison U., Sackville
- 9326 Mt. Royal Jr. C., Calgary
- 0865 Mt. St. Vincent U., Rockingham
- 0661 Northern Alberta Inst. of Tech., Edmonton
- 9603 Northern Lights C., Ft. St. John
- 9201 Nurses Assoc. of New Brunswick, Fredericton
- 9536 Okanagan C., Kelowna
- 0211 Ontario C. Application Service, Guelph
- 9511 Ontario C. of Pharmacists, Toronto
- 9558 Ontario Foreign Med. Grad. (Pre-intern), Toronto
- 9450 Order of Nurses of Quebec, Montreal
- 9067 Pacific Inst. of Culinary Arts
- 9210 Pharmacy Exam. Board Canada, Ontario
- 0949 Queens U., Kingston
- 9297 Red Deer C., Red Deer
- 9738 Regent C., Vancouver
- 9115 Registered Nurses Assoc. of British Columbia, Vancouver
- 0886 Ryerson Poly. U., Toronto
- 0953 St. Francis Xavier U., Antigonish
- 0958 St. Mary's U., Halifax
- 9100 Seneca C., King City
- 9212 Seneca C., Willowdale
- 9117 Sheridan C., Canada Oakville, Ontario
- 0999 Simon Fraser U., Burnaby
- 0849 Southern Alberta Inst. of Tech., Calgary
- 0509 Stanstead C.
- 9476 Tech. U. of Nova Scotia, Halifax
- 0896 Trent U., Peterborough
- 0876 Trinity Western U., Langley
- 0540 U. Coll. of the Cariboo, Kamloops
- 0969 U. Du Quebec A Montreal
- 0963 U. of Alberta, Edmonton
- 0965 U. of British Columbia, Vancouver
- 0813 U. of Calgary
- 0892 U. of Guelph
- 0855 U. of Lethbridge
- 0973 U. of Manitoba, Winnipeg
- 0992 U. of Montreal
- 0976 U. of New Brunswick, Fredericton
- 0485 U. of New Brunswick, Saint John
- 0320 U. of Northern British Columbia, Prince George
- 0993 U. of Ottawa
- 0941 U. of Prince Edward Island, Charlottetown
- 0830 U. of Regina
- 0980 U. of Saskatchewan, Saskatoon

**(Canada cont.)**

- 0982 U. of Toronto, Toronto:
- 0989 U. of Victoria
- 0996 U. of Waterloo
- 0984 U. of Western Ontario, London
- 0904 U. of Windsor
- 9379 U. of Winnipeg
- 0658 Vancouver Comm. C.
- 0964 Vanier C., St. Laurent
- 0893 Wilfrid Laurier U., Waterloo
- 9191 World U. Service of Canada, Ottawa
- 0894 York U., North York

**Agencies and Institutions Outside the US and Canada**

**AMERICAN SAMOA**

- 0020 American Samoa Comm. C., Pago Pago
- 9401 Department of Educ., Pago Pago

**ARGENTINA**

- 0088 IAE-Universidad Austral, Buenos Aires
- 9417 P.A.O., Buenos Aires

**AUSTRALIA**

- 0506 Australian Natl. U., Canberra
- 9826 Curtin U. of Tech., Perth
- 0765 Deakin U., Victoria
- 9823 Flinders U., Adelaide
- 9619 Griffith U., Queensland
- 9811 James Cook U., N. Queensland
- 9785 La Trobe U., Victoria
- 0850 MacQuarie U., Sydney
- 0782 Monash U., Victoria
- 9778 Queensland U. of Tech., Brisbane
- 9728 RMIT, Melbourne
- 0054 Swinburne U. of Tech., Melbourne
- 0727 U. of Adelaide
- 9837 U. of Canberra
- 0974 U. of Melbourne, Victoria
- 9668 U. of New England, NSW
- 0890 U. of New South Wales, Sydney
- 0987 U. of Queensland, Brisbane
- 9840 U. of South Australia, Adelaide
- 0867 U. of Sydney
- 0743 U. of Technology, Sydney
- 0051 U. of Western Australia, Perth
- 0380 U. of Western Sydney
- 9799 U. of Wollongong
- 9786 Victoria U. of Tech., Melbourne

**AUSTRIA**

- 0547 Webster U., Vienna
- 0609 Wirtschaftsuniversität Wien, Wien

**BELGIUM**

- 0814 Boston U. Overseas Grad. Prog., Bruxelles
- 0014 Bureau D'admission de College, Belgique
- 0753 International Management Inst.
- 0749 Katholieke U., Leuven
- 9866 United Business Institutes, Brussels
- 0550 Universiteit Libre De Bruxelles
- 3574 Vrije U/Vesalius C., Bruxelles

**BOLIVIA**

- 9418 P.A.O., La Paz

**BRAZIL**

- 9340 Agency Intl. Development (USAID), Brasilia
- 9720 Escola Graduada de São Paulo, São Paulo
- 9419 P.A.O., Brasilia

**BULGARIA**

- 2451 American U. in Bulgaria, Blagoevgrad

**CHILE**

- 9420 P.A.O., Santiago

**COLOMBIA**

- 9389 C.A.O., Bogota

**COSTA RICA**

- 9460 P.A.O., San Jose

**CYPRUS**

- 9454 U.S. Educ. Commsn., Cyprus, Nicosia

**CZECH REPUBLIC**

- 9734 Anglo-American C. in Prague
- 0361 Czechoslovakia Management CTR, Celakovice

**DOMINICAN REPUBLIC**

- 9434 C.A.O., Santo Domingo

<b>ECUADOR</b>	
9422	P.A.O., Quito
<b>EGYPT</b>	
0903	American U., Cairo
9404	AMIDEAST, Cairo
9842	Cairo American C., Cairo
<b>ENGLAND</b>	
0645	American Intercontinental U., London
0619	Ashridge Management C., Hertfordshire
0869	Aston U., Birmingham
9960	Brunel U.
9647	Chantal Eley, Surrey
0870	City U., London
0822	Cranfield Inst. of Tech.
0244	Goldsmiths C., London
0951	Heriot-Watt U., Edinburgh
0891	Imperial C. of Sciences & Tech., London
0618	Keele U.
0394	Kings C., London
0838	London Business Sch.
0499	London Sch. Hygiene & Tropical Medicine
0972	London Sch. of Economics/Political Science
0804	Manchester Business Sch.
0827	Manchester Sch. Mgt.
9719	Middlesex U., London
9098	Nottingham Trent U.
9161	Queen Mary and Westfield Col.
0823	Richmond C., London
0441	Royal Holloway U. of London, Surrey
9524	St. Clare's, Oxford
9163	U. of College of London
0869	U. of Aston Birmingham, Birmingham
0971	U. of Bath
0968	U. of Birmingham
0828	U. of Bradford
0816	U. of Bristol
0908	U. of Cambridge
9178	U. of East Anglia, Norwich
3461	U. of Exeter
0783	U. of Hull
0826	U. of Kent, Canterbury
0801	U. of Lancaster
3068	U. of Leeds
3407	U. of Leicester
0845	U. of Liverpool
9961	U. of London
0752	U. of Newcastle Upon Tyne, Newcastle/Tyne
3464	U. of Nottingham
0490	U. of Oxford, Grad. Admissions
0807	U. of Oxford, Sch. Mgt. Studies
0769	U. of Reading
0846	U. of Sheffield
9162	U. of Southampton
0554	U. of Surrey
9166	U. of Sussex
0806	U. of Warwick, Coventry
3065	U. of York
9733	U.S. Intl. U., Hertfordshire
<b>ESTONIA</b>	
0133	U. of Tartu
<b>FED. STATES OF MICRONESIA</b>	
0115	C. of Micronesia, Pohnpei
9443	District Educ. Admin., Yap
<b>FINLAND</b>	
0636	Helsinki Sch. Econ. and Business Admin.
9872	U. of Helsinki
9871	U. of Tampere
<b>FRANCE</b>	
9648	American Intl. Sch., Nice
0866	American U. in Paris
0700	Centre Intl. d'Admission au Mgt. (CIAM), Jouy-en-Josas
9792	Ecole D'Ingenieurs de Tours, Cedex
0056	Ecole D'Ingenieurs Du Val, Cedex
9530	Ecole des Cadres (EDC), Courbevoie
0171	Ecole Natl. D'ing D Tech. D Ind, Nantes
0326	Ecole Natl. Supr. Arts Et Metiers, Talence
0191	Ecole Natl. Supr. Arts Et Motte, Aix-En Provence
9360	Ecole Natl. Supr. Arts & Metiers (ENSAM), Angers
0166	Ecole Natl. Supr. Telecom 3, Paris
9336	Ecole Polytechnique Feminine, Sceaux
9249	Ecole Practiciens Commerce Intl. (EPCCI), Cergy Pontoise
0057	Ecole Sup. d'Ingenieurs De Nice
0199	Ecole Sup. Libre des Sci. Comm. Appl. (ESLSCA), Paris
0190	Enseinh. Toulouse
9617	ESC, Poitiers
0165	ESC, Troyes
9548	ESCIL, Villeurbanne
9071	ESSEC M.S. Graduate Sch. of Mgmt.
9496	Franco-American Commsn. Educ. Exch., Paris
0147	Groupe ESC Chambéry

<b>(France cont.)</b>	
0161	Groupe ESC Nantes Atlantique, Nantes
0566	Groupe ESC Normandie, Le Havre
3244	I.N.S.E.A.D./PhD. Prog., Cedex
9533	I.N.S.E.E.C., Bordeaux
0714	I.N.S.E.E.C., Paris
0970	Inst. European d'Administration des Affaires, Fontainebleau
0652	Inst., Franco-Amer. de Mgt., Paris
9352	Inst. National des Sciences Appliquees, (INSA), Villeurbanne
0739	Inst. Supr. de Gestion, Paris
0649	Inst., Supr. des Affaires, Jouy-en-Josas
0675	Inst. Supr. du Commerce (ISC), Paris
0189	Inst. Universitaire De Tech, Mulhouse
0337	L'Ecole Louis De Broglie, Bruz Rennes
0134	Lincoln Intl. Business Sch., Paris
0484	MIB Ecole Natl. des Ponts ET Chaussees(ENPC), Paris
9282	Ministere des Affaires Etrangeres, Paris
0667	U. Hartford Business Sch., Puteaux
0632	U. Lyon 111
0463	Université Claude Bernard Lyon., Cedex
<b>GERMANY</b>	
8183	Aalen U. of Applied Sciences
9789	Bad Homburger Akademie
9233	Fulbright Kommission, Bonn
0404	Leipzig Grad. Sch. of Mgmt.
0835	Schiller Intl. U., Heidelberg
9777	Technische U. Braunschweig
0683	U. of Karlsruhe
0988	U. of Maryland, Mannheim
1653	U. of Maryland, C. Mim Prg., Schwabisch Gmünd
0460	U. of Stuttgart
9403	Universität Tubingen
0682	WHU Koblenz, Vallendar
<b>GREECE</b>	
0925	American C. of Greece-Deree, Athens
9393	Anatolia C., Thessaloniki
9337	Athens C.
9351	Pierce C. H.S., Athens
9569	U. of LaVerne, Athens Center
<b>GUAM</b>	
0959	U. of Guam, Mangilao
<b>GUATEMALA</b>	
9435	P.A.O., Guatemala City
9562	U. del Valle de Guatemala, Guatemala City
<b>HONDURAS</b>	
9424	P.A.O., Tegucigalpa
<b>HONG KONG</b>	
0812	Chinese U., Sha Tin
0170	Hong Kong U. of Sci. & Tech., Kowloon
9300	Inst. of Intl. Educ., Wanchai
9303	Lingnan U., Tuen Mun, N.T.
9671	U. of Hong Kong
<b>HUNGARY</b>	
0069	Central European U., Budapest
0203	IMC Graduate Sch. Business
9805	Jozsef Attila U. Library, Szeged
9804	Lajos Kossuth U., Debrecen
9807	Library of Chemistry U., Veszprem
9806	Miskolc Tech. U.
9717	Soros Foundation, Hungary
9802	Szabo Ervin Library, Budapest
9801	Technical U. of Budapest
<b>INDIA</b>	
0035	Indian Inst. of Tech., Bengal
0117	Inst. of Chartered Fin. Analysis of India, Hyderabad, (ICFI)
1043	Maharishi Inst. of Mgt. (MIM), New Delhi
9425	P.A.O., New Delhi
0833	U. of Bombay
9364	U.S. Educ. Fdn. India (USEFI), New Delhi
<b>INDONESIA, REP. OF</b>	
9313	Agency for Agric. Research & Development, Bogor
9356	Agency Intl. Development (USAID) Training Office, Jakarta
9366	Gallex Pacific Indonesia, Rumbai-Pakanbaru
9397	Inst. of Tech., Bandung
0451	Bandung Language Center of IKIP, Bandung
9508	National Development Planning Agency, Jakarta
9475	P.A.O., Jakarta
<b>ISRAEL</b>	
9194	AMIDEAST, Jerusalem
0688	Boston U., Israel

<b>ITALY</b>	
0698	Bocconi U., Milan
9729	Bologna Center, Johns Hopkins U., Bologna
9832	English Centre, Ravenna
9190	Fondazione Rui, Rome
0784	John Cabot U., Rome
9383	P.A.O., Rome
0495	Politecnico Di Milano, Lecco
9795	Politecnico DI Milano, Milano
<b>JAPAN</b>	
0794	Aoyama Gakuin U., Tokyo
9870	Chukyo U., Aichi
0436	Hitotsubashi U., Tokyo
0151	Chou U., Tokyo
9220	Industrial Bank of Japan, Tokyo
8022	Intl. Christian U. High School, Tokyo
0860	Intl. Christian U., Tokyo
0712	Intl. U. of Japan, Niigata
9478	Japan-U.S. Educ. Commsn., Tokyo
0773	Keio U., Tokyo
9746	Kumamoto Gakuen U.
3818	Kwansei Gakuin U. Nishinomiya
9669	Kyoto Intl. U., Kyoto
9501	Kyoto U., Kyoto
0411	Kyushu U., Fukoka
0413	Meiji U., Tokyo
9512	Ministry of Foreign Affairs, Tokyo
0477	Miyazaki Intl. C.
0312	Nagoya U.
9477	Nanzan U., Nagoya
9630	Nevada Ca. Intl. Consortium, Tokyo
0586	Nihon U., Tokyo
9669	Phillips U. Intl., Kyoto
0751	Rikkyo U., Tokyo
0659	Ritsumeikan U., Kyoto
0819	Sophia U., Tokyo
9400	Takushoku U., Tokyo
9758	Teachers C., Japan Prog., Tokyo
9698	Temple U., Tokyo
9611	Tokyo Womens Christian U.
9657	Toyo Eiwa U., Kanagawa
9757	U. of Rio Grande, Tokyo
0259	U. of Tokyo
0439	U. of Tsukuba, Ibaraqi
9342	Waseda U., Tokyo
<b>JORDAN</b>	
9180	AMIDEAST, Amman
9426	P.A.O., Amman
<b>KENYA</b>	
0731	United States Intl. U., Nairobi
<b>KOREA</b>	
9679	Citizen's National Bank
9327	Fellowship Award Prog., Seoul
9241	International Scientific & Cultural Research Institution
0195	Korea Advanced Institute of Science & Technology-Taejon
9350	Korean-American Educ. Commsn., Seoul
9675	Kumho Company, Inc., Seoul
0144	Kwangju Inst. of Sci. & Tech. (Postech)
9411	P.A.O., Seoul
0329	Pohang U. of Science & Tech.
9659	Securities Supervisory Board, Seoul
0489	Supreme Court of Korea, Seoul
9893	Yonsei U., Seoul
<b>KUWAIT</b>	
0768	Kuwait U.
<b>LAOS</b>	
9436	P.A.O., Vientiane
<b>LEBANON</b>	
0902	American U., Beirut
9200	AMIDEAST, Beirut
9252	U.S. Embassy, Beirut
<b>MALAYSIA</b>	
0005	American Degree Prog., Selangor
<b>MALI</b>	
9537	Agency Intl. Development (USAID)
<b>MARIANA ISLANDS</b>	
9402	District Director of Educ., Saipan
0781	Northern Marianas C., Saipan
<b>MARSHALL ISLANDS</b>	
9447	District Scholarship Committee, Majuro
<b>MEXICO</b>	
9910	Duxx Grad. Sch. of Business, N.L.
9718	Inst. Intl. Educ., Mexico
0843	Inst. Tecn Estudios Superiores (ITESM)
9427	P.A.O., Mexico City
9852	Universidad de Monterrey, Mexico

<b>MOROCCO</b>	
9670	American Language Center, Rabat
9521	AMIDEAST, Rabat
<b>NEPAL</b>	
9437	P.A.O., Kathmandu
<b>NETHERLANDS</b>	
0798	Erasmus U., Rotterdam
9202	Nijenrode Netherlands Sch. Business, Breukelen
0542	Wageningen Agric. U.
0548	Webster U., Leiden
0398	Universiteit Van Amsterdam
9678	U. of Amsterdam ACCESS
<b>NEW ZEALAND</b>	
9782	Dominion English Schools, Auckland
9480	Massey U., Palmerston North
9689	Nursing Council of New Zealand, Wellington
9481	U. of Auckland
9482	U. of Canterbury, Christchurch
9483	U. of Otago, Dunedin
9484	U. of Waikato, Hamilton
9485	Victoria U., Wellington
<b>NICARAGUA</b>	
9438	P.A.O., Managua
<b>NIGERIA</b>	
9396	P.A.O., Lagos
<b>NORWAY</b>	
0686	Norwegian Sch. of Economics/Business, Bergen
0529	Norwegian Sch. of Management, Sandvika
9652	Norwegian U. of Sci. and Tech., Dragvoll
9367	U. of Bergen
0756	U. of Oslo
0742	U. of Tromso
<b>PAKISTAN</b>	
0096	Gik Inst., Topi-Swabi
9654	Ministry of Science & Tech., Islamabad
9463	P.A.O., Karachi
9388	U.S. Educ. Fdn., Islamabad
9387	U.S. Embassy, Islamabad
9304	USAID, Islamabad
<b>PALAU</b>	
9444	District Educ. Administrator, Koror
9455	Palau Comm. C., Koror
<b>PANAMA</b>	
0909	Panama Canal C., Balboa
9439	P.A.O., Panama City
<b>PARAGUAY</b>	
9458	P.A.O., Asuncion
<b>PEOPLE'S REPUBLIC OF CHINA</b>	
0744	China Intl. Examinations Coordination Bureau, Beijing
<b>PERU</b>	
9499	Commsn. for Educ. Exch. U.S./PERU, Lima
9428	P.A.O., Lima
<b>PHILIPPINES</b>	
9321	Ministry of Educ. and Culture, Manila
9466	P.A.O., Manila
9307	Philippine-American Educ. Fdn., Manila
0978	U. of Philippines, Quezon City
<b>PORTUGAL</b>	
0722	New U. of Lisbon
<b>PUERTO RICO</b>	
0979	U. of Puerto Rico, Rio Piedras
<b>SAMOA</b>	
0200	American Samoa Comm. C., Pago Pago
9391	Church C. of Western Samoa, Apia
<b>SAUDI ARABIA</b>	
9406	Arabian American Oil Co., Dhahran
9072	Saudi Arabian Airlines
0868	U. of Petroleum & Minerals, Dhahran
<b>SCOTLAND</b>	
0951	Heriot-Watt U., Edinburgh
0818	U. of Aberdeen
0917	U. of Edinburgh
0923	U. of Glasgow
0881	U. of Stirling
0841	U. of Strathclyde, Glasgow
<b>SINGAPORE</b>	
7037	Center for American Education
0138	Nanyang Tech. U.
9705	Nanyang Tech. U., MBA

<b>(Singapore cont.)</b>	
0677	National U., Singapore
0009	Public Serv. Commsn., Singapore
<b>SOUTH AFRICA</b>	
0837	U. of Cape Town
0991	U. of Witwatersand
<b>SPAIN</b>	
9214	Commsn. for Educ. Exch. U.S./SPAIN, Madrid
0884	Escuela Supr De Admin Empresas
0707	Inst. De Empresa, Spain
0208	Universitat Pompeu Fabra
9727	Fundación Familiar Catalana, Barcelona
0755	U. De Navarra, IESE, Barcelona
<b>SRI LANKA</b>	
0276	Inst. of Tech. Studies, Colombo
9456	P.A.O., Colombo
<b>SWEDEN</b>	
0008	Stockholm U.
9520	VHS, National Admsn. to Higher Educ., Stockholm
<b>SWITZERLAND</b>	
0878	American C. of Switzerland, Leysin
9756	American Grad. Sch. of Business
9523	Art Center C. of Design, Peilz
0922	Franklin C.
0705	GSBA Zurich/OEKREAL Fdn.
9827	Hotel Mgt. School, Valais
8077	Kumon Leysin Acad. of Switzerland
9295	Lutheran World Federation, Geneva
0445	Zurich Sch. for Translation/ Interpretation
<b>SYRIA</b>	
9522	AMIDEAST, Damascus
<b>TAIWAN</b>	
9412	American Inst. of Taiwan, Taipei
9253	Fdn. for Scholarly Exch., Taipei
9145	Ministry of Educ., Taipei
<b>THAILAND</b>	
9474	Agency Intl. Development (USAID), Bangkok
9344	American Language Inst., Bangkok
0918	Asian Inst. of Tech., Bangkok
0706	Assumption U., Bangkok
0697	Bangkok Krungthep U.
9318	Chulalongkorn U., Bangkok
9573	CIDA, Bangkok
9275	Dept. of Tech./Economic Coop. (DTEC), Bangkok
9349	East-West Center, Bangkok
9343	Inst. of Intl. Educ., Bangkok
8084	Intl. School of Bangkok
9341	Kasetsart U., Bangkok
0302	National Inst. Devlp. Admin., Bangkok
0459	Stamford Intl. C., Bangkok
9370	Thailand-U.S. Educ. Fdn., Bangkok
9384	Thammasat U., Bangkok
0091	Thammasat U. SIIT Rangsit, Pathumthani
9474	USAID/Thailand, Bangkok
<b>TOGO</b>	
9517	U.S. Embassy, Lome
<b>TONGA</b>	
9390	Liahona H.S., Nuku Alofa
<b>TUNISIA</b>	
9182	AMIDEAST, Tunis
<b>TURKEY</b>	
0620	Bilkent U., Ankara
0796	Bogazici U., Istanbul
0163	Koc U., Istanbul
0692	Middle East Tech. U., Ankara
9221	U.S. Embassy, Ankara
<b>UNITED ARAB EMIRATES</b>	
0442	Sharjah C.
<b>URUGUAY</b>	
9441	P.A.O., Montevideo
<b>VENEZUELA</b>	
9431	P.A.O., Caracas
<b> VIRGIN ISLANDS</b>	
0879	U. of Virgin Islands, Charlotte Amalie
<b>WEST INDIES</b>	
5964	American U., of the Caribbean
<b>WALES</b>	
0064	U. of Wales C. of Cardiff
<b>YEMEN</b>	
9181	AMIDEAST Sana'a
9433	P.A.O., Sana'a

# List B: Department Codes

This list is only for students applying for **graduate** study. **If you are not applying for graduate study**, you must fill in **00** as the department code for each institution or agency you list.

## 02 - Graduate Schools of Management 03 - Law Schools

**Graduate Schools:** If you are applying for graduate study in a field other than business or law, copy the appropriate code from the list below.

### HUMANITIES

- 11 Archaeology
- 12 Architecture
- 26 Art History
- 13 Classical Languages
- 28 Comparative Literature
- 53 Dramatic Arts
- 14 English
- 29 Far Eastern Languages and Literature
- 15 Fine Arts, Art, Design
- 16 French
- 17 German
- 04 Linguistics
- 19 Music
- 57 Near Eastern Languages and Literature
- 20 Philosophy
- 21 Religious Studies or Religion
- 22 Russian/Slavic Studies
- 23 Spanish
- 24 Speech
- 10 Other foreign languages
- 98 Other humanities

### SOCIAL SCIENCES

- 27 American Studies
- 81 Anthropology
- 82 Business and Commerce
- 83 Communications
- 84 Economics
- 85 Education (including M.A. in Teaching)
- 01 Educational Administration
- 70 Geography
- 92 Government
- 86 History
- 87 Industrial Relations and Personnel
- 88 International Relations
- 18 Journalism
- 90 Library Science
- 91 Physical Education
- 97 Planning (City, Community, Urban, Regional)
- 92 Political Science
- 93 Psychology, Clinical
- 09 Psychology, Educational
- 58 Psychology, Experimental/Developmental

### SOCIAL SCIENCES (cont.)

- 79 Psychology, Social
- 08 Psychology, other
- 94 Public Administration
- 50 Public Health
- 95 Social Work
- 96 Sociology
- 80 Other social sciences

### BIOLOGICAL SCIENCES

- 31 Agriculture
- 32 Anatomy
- 05 Audiology
- 33 Bacteriology
- 34 Biochemistry
- 35 Biology
- 45 Biomedical Sciences
- 36 Biophysics
- 37 Botany
- 38 Dentistry
- 39 Entomology
- 46 Environmental Science
- 40 Forestry

### BIOLOGICAL SCIENCES (cont.)

- 06 Genetics
- 41 Home Economics
- 25 Hospital and Health Services Administration
- 42 Medicine
- 07 Microbiology
- 74 Molecular and Cellular Biology
- 43 Nursing
- 77 Nutrition
- 44 Occupational Therapy
- 56 Pathology
- 47 Pharmacy
- 48 Physical Therapy
- 49 Physiology
- 50 Public Health
- 55 Speech-Language Pathology
- 51 Veterinary Medicine
- 52 Zoology
- 30 Other biological sciences

### PHYSICAL SCIENCES

- 54 Applied Mathematics
- 61 Astronomy
- 62 Chemistry
- 78 Computer Sciences
- 63 Engineering, Aeronautical
- 64 Engineering, Chemical
- 65 Engineering, Civil
- 66 Engineering, Electrical
- 67 Engineering, Industrial
- 68 Engineering, Mechanical
- 69 Engineering, other
- 71 Geology
- 72 Mathematics
- 73 Metallurgy
- 75 Oceanography
- 76 Physics
- 59 Statistics
- 60 Other physical sciences

Use 99 for any department not listed.

# List C: Country and Region Codes

- 001 Afghanistan
- 003 Albania
- 005 Algeria
- 007 American Samoa
- 008 Andorra
- 010 Angola
- 011 Anguilla
- 012 Antigua and Barbuda
- 015 Argentina
- 016 Armenia
- 017 Aruba
- 020 Australia
- 025 Austria
- 029 Azerbaijan
- 030 Azores
- 035 Bahamas
- 040 Bahrain
- 045 Bangladesh
- 050 Barbados
- 094 Belarus
- 055 Belgium
- 056 Belize
- 058 Benin
- 060 Bermuda
- 063 Bhutan
- 065 Bolivia
- 069 Bosnia and Herzegovina
- 070 Botswana
- 075 Brazil
- 077 British Virgin Islands
- 081 Brunei Darussalam
- 085 Bulgaria
- 593 Burkina Faso
- 092 Burundi
- 307 Cambodia
- 095 Cameroon
- 100 Canada
- 106 Cape Verde
- 110 Cayman Islands

- 113 Central African Republic
- 114 Chad
- 115 Chile
- 457 China, People's Republic of
- 120 Colombia
- 122 Comoros
- 630 Congo-DR Congo (Formerly Zaire)
- 125 Congo Republic
- 126 Cook Islands
- 130 Costa Rica
- 290 Côte d'Ivoire (Ivory Coast)
- 133 Croatia
- 135 Cuba
- 140 Cyprus
- 142 Czech Republic
- 150 Denmark
- 153 Djibouti
- 154 Dominica, Commonwealth of
- 155 Dominican Republic
- 165 Ecuador
- 170 Egypt
- 175 El Salvador
- 180 England
- 183 Equatorial Guinea
- 182 Eritrea
- 184 Estonia
- 185 Ethiopia
- 187 Faeroe Island
- 107 Federated States of Micronesia
- 190 Fiji
- 195 Finland
- 200 France
- 203 French Guiana
- 202 French Polynesia
- 204 Gabon

- 205 Gambia, The
- 206 Gaza Strip
- 208 Georgia
- 210 Germany
- 215 Ghana
- 220 Greece
- 225 Greenland
- 227 Grenada
- 228 Guadeloupe
- 229 Guam
- 230 Guatemala
- 233 Guinea
- 234 Guinea-Bissau
- 235 Guyana
- 240 Haiti
- 245 Honduras
- 250 Hong Kong
- 251 Hungary
- 255 Iceland
- 260 India
- 265 Indonesia
- 270 Iran
- 273 Iraq
- 275 Ireland
- 277 Isle of Man
- 280 Israel
- 285 Italy
- 295 Jamaica
- 300 Japan
- 305 Jordan
- 308 Kazakhstan
- 310 Kenya
- 312 Kiribati
- 314 Korea (DPR)
- 315 Korea (ROK)
- 320 Kuwait
- 323 Kyrgyzstan
- 325 Laos
- 328 Latvia

- 330 Lebanon
- 333 Lesotho
- 335 Liberia
- 340 Libya
- 343 Liechtenstein
- 344 Lithuania
- 345 Luxembourg
- 347 Macau
- 348 Macedonia, former Yugoslav Republic of
- 350 Madagascar
- 353 Madeira Islands
- 355 Malawi
- 360 Malaysia
- 361 Maldives
- 363 Mali
- 365 Malta
- 367 Northern Mariana Islands
- 368 Marshall Islands
- 366 Martinique
- 369 Mauritania
- 370 Mauritius
- 375 Mexico
- 376 Moldova
- 378 Monaco
- 379 Mongolia
- 381 Montserrat
- 380 Morocco
- 385 Mozambique
- 090 Myanmar (Burma)
- 388 Namibia
- 386 Nauru
- 387 Nepal
- 390 Netherlands
- 395 Netherlands Antilles
- 396 New Caledonia
- 405 New Zealand
- 420 Nicaragua
- 425 Niger

- 430 Nigeria
- 433 Niue Island
- 434 Northern Ireland
- 435 Norway
- 443 Oman
- 445 Pakistan
- 447 Palau
- 450 Panama
- 400 Papua New Guinea
- 455 Paraguay
- 460 Peru
- 465 Philippines
- 470 Poland
- 475 Portugal
- 474 Puerto Rico
- 477 Qatar
- 482 Reunion
- 483 Romania
- 484 Russia
- 487 Rwanda
- 486 St. Kitts and Nevis
- 521 St. Lucia
- 522 St. Vincent and the Grenadines
- 488 San Marino
- 489 Sao Tome and Principe
- 490 Saudi Arabia
- 495 Scotland
- 497 Senegal
- 498 Seychelles
- 500 Sierra Leone
- 505 Singapore
- 503 Slovakia
- 504 Slovenia
- 506 Solomon Islands
- 507 Somalia
- 510 South Africa
- 515 Spain
- 520 Sri Lanka

- 525 Sudan
- 527 Suriname
- 530 Swaziland
- 535 Sweden
- 540 Switzerland
- 545 Syria
- 550 Tahiti
- 555 Taiwan
- 556 Tajikistan
- 560 Tanzania
- 565 Thailand
- 567 Togo
- 570 Tonga
- 575 Trinidad and Tobago
- 580 Tunisia
- 584 Turkmenistan
- 585 Turkey
- 586 Turks and Caicos Islands
- 587 Tuvalu
- 590 Uganda
- 589 Ukraine
- 591 United Arab Emirates
- 588 United Kingdom\*
- 592 United States of America
- 607 US Virgin Islands
- 595 Uruguay
- 594 Uzbekistan
- 596 Vanuatu
- 597 Vatican City
- 600 Venezuela
- 605 Vietnam
- 610 Wales
- 611 West Bank
- 620 Samoa
- 623 Yemen
- 625 Yugoslavia
- 635 Zambia
- 480 Zimbabwe

Use 999 for any country/region not listed.

\*See England, Scotland, Wales, and Northern Ireland.

# TOEFL

## TOEFL Essay Rescoring Request Form

I request that the following be rescored: **Enclosed**  
 TOEFL essay for the test date indicated below . . . . . **US\$50**

Appointment Confirmation Number: \_\_\_\_\_

Test Date: \_\_\_\_\_ Birth Date: \_\_\_\_\_

Name: \_\_\_\_\_  
Family Name (Surname) Given Name Middle Name

Signature: \_\_\_\_\_

Address: \_\_\_\_\_

\_\_\_\_\_

Postal Code: \_\_\_\_\_

Check if paying by: <input type="checkbox"/> American Express <input type="checkbox"/> Discover <input type="checkbox"/> JCB																	
<input type="checkbox"/> MasterCard <input type="checkbox"/> VISA and enter your card number and expiration date.																	
Credit Card Expiration Date (Month)														— (Year)			

If paying by credit card, you may fax this form to TOEFL at 1-609-771-7500.



Copyright © 2001 by Educational Testing Service, Princeton, NJ.



**Mailing Slip for Rescoring Results — Do Not Detach.**  
Print your name and address below.

TOEFL Services  
P.O. Box 6151  
Princeton, NJ 08541-6151, USA

573-18

Name \_\_\_\_\_

Address \_\_\_\_\_

Postal Code \_\_\_\_\_

CUT HERE

CUT HERE

ESSAY RESCORING FORM

You may request that your TOEFL essay be rescored up to **six months** after your test date.

Your TOEFL essay will be scored independently by two readers who have not seen it previously. If the rescoring procedure confirms your original score, you will be so notified by letter. If the rescoring procedure results in an increase or a decrease of your essay rating, your Structure/Writing score, and your total score, you will receive a revised examinee's score record. Revised official score reports will also be sent to the institutions that received your scores. These revised scores will become your official scores.

Complete the form on this page and send it, with the required fee of **US\$50**, to TOEFL Services, P.O. Box 6151, Princeton, NJ 08541-6151, USA. Checks must be made payable to ETS-TOEFL. If you are paying by credit card,

this form may be faxed. Faxed requests will not be processed unless complete credit card information is provided. The fax number is 1-609-771-7500.

**NOTES:** All forms will be processed upon receipt, and a charge will be made to your credit card. If you think your faxed form may not have been received by TOEFL Services, and you attempt to send the information again, write "DUPLICATE" in large letters on all repeat requests. This will help avoid extra processing by TOEFL Services and unnecessary charges to your credit card.

The results of the rescoring will be available about three weeks after the receipt at TOEFL Services of your Rescoring Request Form and fee.

**Methods of Payment:** Make payments out to ETS-TOEFL. See page 5 for acceptable forms of payment. **Do not send cash. Receipts for bank checks or bank money orders are not acceptable.** The actual negotiable check or money order **MUST** be enclosed with a signed request form or the form will be returned to you. *If you are paying by credit card*, write the number of your American Express, Discover, JCB, MasterCard or VISA card (no other credit card may be used). Enter the month and year of your card's expiration date in the spaces indicated. The total amount due will be calculated automatically at ETS and billed to your account.

# Score Report Requests

Complete the form below to request TOEFL official score reports for institutions you did NOT indicate on test day. Remember that scores more than two years old cannot be reported or verified.

The form will be returned to you if you do not give complete information or if you do not enclose the correct fee.

Do not send a letter with this form. It will cause delay.

Score reports will be mailed to the institutions you listed approximately **two weeks** after your test date if you compose your essay on the computer. If you handwrite your essay, score reports will be mailed approximately **five weeks** after your test date. **UNDER NO CIRCUMSTANCES CAN SCORE REPORTS BE MAILED ANY EARLIER.**

Scores will be mailed within two weeks after TOEFL Services receives your request. An acknowledgment confirming that your official score reports were mailed will be sent to you by mail.

## HOW TO FILL IN THE FORM

To complete the form, follow the instructions below.

Fill in your appointment confirmation number, name, date of birth, and test date.

To order an official score report for an institution, look at List A: Institution Codes (see pages 54-58). Find the name of the institution to which you want your official score report sent. Then print the name, address, and code number in the spaces provided. **If you are applying to an institution that is not listed, contact the institution or agency and ask it to provide you with its ETS/TOEFL-assigned code number**, or you can ask TOEFL Services for the code number. If the institution or agency does not have an ETS/TOEFL-assigned code number, fill in the institution name and the complete mailing address, but leave the institution code area blank.

If you plan to study at the **undergraduate level**, or if the institution is not a college or university, leave the space for department name blank and write **00** in the boxes for department code.

If you are applying for **graduate study** (that is, you have already earned a bachelor's degree at a college or university), look at **List B: Department Codes** (see page 59). Find the name of the department in which you plan to study and then copy the name and two-number code. If your department is not listed, write 99 in the spaces for

department code. **You must write a department code number** so TOEFL Services can send your score report to the office the graduate institution has named to receive TOEFL score reports. If you do not write a department code, the TOEFL office will not send an official score report to the institution.

**NOTE:** After you submit your completed form, you cannot delete or change designated institutions or department codes. List no more than four institutions on this form. If you wish to order more than four reports, you may photocopy the form.

## PAYMENT

- See page 5 for acceptable forms of payment. **Do not send cash. Receipts for bank checks or bank money orders are not acceptable.** The actual negotiable check or money order must accompany the form. If you are paying by credit card, write in the number of your American Express, Discover, JCB, MasterCard or VISA card (no other credit card may be used). Enter the month and year of your card's expiration date in the spaces indicated. The total amount due will be calculated automatically at ETS and billed to your account.
- If you do not send enough money, the TOEFL office will send reports only to as many institutions as you paid for, **no matter how many you requested.** (Fees are subject to change without notice.)
- Sign and date the form before mailing.
- Mail this form and payment to: **TOEFL**, P.O. Box 6153, Princeton, NJ 08541-6153, USA.
- If you are paying by credit card, this form may be faxed. Faxed requests will not be processed unless complete credit card information is provided. The fax number is 1-609-771-7500.

**NOTE:** All Score Report Request Forms will be processed upon receipt, and a charge will be made to your credit card. If you think your faxed Score Report Request Form may not have been received by TOEFL Services, and you attempt to send the information again, write "DUPLICATE" in large letters on all repeat requests. This will help avoid extra processing by TOEFL Services and unnecessary charges to your credit card.

CUT HERE ✂



**Score Report Request Form** (Do not use this form after June 30, 2002.)

Read the directions above. All the information requested must be given or the form will be returned to you.

**Scores more than two years old cannot be reported or verified.**

Check if paying by:  American Express  Discover  JCB  
 MasterCard  VISA and enter your card number and expiration date.

Credit Card Expiration Date  
  -

Check the appropriate box to show the number of reports you are requesting.

Amount Due in US Dollars*			
1	2	3	4
<input type="checkbox"/>	<input type="checkbox"/>	<input type="checkbox"/>	<input type="checkbox"/>
\$12	\$24	\$36	\$48

\*Make payable to ETS TOEFL. In Canada add GST/HST (Reg. #13141 4468RT) to total remittance.

APPOINTMENT CONFIRMATION/REGISTRATION NUMBER

<small>NAME: Print your family name (surname), given name, then middle name, if you have one.</small>		<small>Mo.</small> <input type="text"/> <small>Day</small> <input type="text"/> <small>Year</small> <input type="text"/>	<small>Mo.</small> <input type="text"/> <small>Year</small> <input type="text"/>	<small>CENTER NUMBER</small>	<small>ETS USE ONLY</small>	
<small>INSTITUTION</small>	<small>ADDRESS</small>	<small>INSTITUTION CODE</small>	<small>NAME OF DEPARTMENT</small>	<small>DEPT. CODE</small>		
<input type="text"/>	<input type="text"/>	<input type="text"/>	<input type="text"/>	<input type="text"/>		
<input type="text"/>	<input type="text"/>	<input type="text"/>	<input type="text"/>	<input type="text"/>		

YOUR MAILING ADDRESS

Check the box if your address has changed since the test date you indicated above. Print your correct address on the back of this form.

I authorize ETS to release my TOEFL scores to the institutions designated above, under the conditions set forth in the *Information Bulletin*.

YOUR SIGNATURE \_\_\_\_\_ DATE \_\_\_\_\_



Copyright © 2001 by Educational Testing Service, Princeton, NJ

**THIS FORM MAY BE PHOTOCOPIED.**

# TOEFL

## Refund Request Form

A partial refund of US\$65 is available if you cancel your appointment within the proper time period or have paid for a CBT voucher but have not used it (see page 5 for refund policy and pages 6 and 8 for cancellation policy). Complete this form and send it to

TOEFL Services  
 P.O. Box 6151  
 Princeton, NJ 08541-6151, USA, or  
 Fax it to: 1-609-771-7500

- Check this box if you canceled your appointment and are requesting a refund.
- Check this box if you received a CBT voucher and are now returning it for a refund.

Name: \_\_\_\_\_  
Family Name (Surname)                      Given Name                      Middle Name

Address: \_\_\_\_\_  
 \_\_\_\_\_  
 \_\_\_\_\_  
 \_\_\_\_\_  
Postal Code

Daytime Phone Number: \_\_\_\_\_



Canceled Test Date    Month      Day      Year

Date of Birth            Month      Day      Year

-  -  -   
 Appointment Confirmation Number

Check if you paid by:  American Express     MasterCard     VISA  
 and enter your card number and expiration date.

Credit Card Expiration Date (Month)   (Year)

 Copyright © 2001 by Educational Testing Service, Princeton, NJ. 

CUT HERE ✂

### GradAdvantage™

### Applying to Graduate School?

Use GradAdvantage™ to make the process of applying to graduate schools and MBA programs easier. Visit the GradAdvantage Web site at <http://www.gradadvantage.org> for details on how this new electronic service can streamline the application process for you.

GradAdvantage™ is offered by Educational Testing Service, in alliance with Peterson's®, and in cooperation with the TOEFL Board and the Graduate Record Examinations® Board.

# WHERE TO GET BULLETINS AND STUDY MATERIALS

*Bulletins* are usually available from local colleges and universities. In addition, *Bulletins* and study materials are also available at many of the locations listed below; at United States educational commissions and foundations, United States Information Service (USIS) offices, binational centers and private organizations; and directly from Educational Testing Service. Additional distribution locations for study materials are listed on the ETS Web site at [www.ets.org/cbt/outsidus.html](http://www.ets.org/cbt/outsidus.html).

## ALGERIA, OMAN, QATAR, SAUDI ARABIA, AND SUDAN

AMIDEAST  
Testing Programs  
1730 M Street, NW, Suite 1100  
Washington, DC 20036-4505, USA  
Telephone: 202-776-9649  
[www.amideast.org](http://www.amideast.org)

## EGYPT

AMIDEAST/CAIRO  
23, Mossadak Street  
Dokki, Cairo, Egypt  
Telephone: 20-2-337-8265  
[www.amideast.org](http://www.amideast.org)  
or  
AMIDEAST  
American Cultural Center  
3 Pharaana Street  
Azarita, Alexandria  
Egypt  
Telephone: 20-3-482-9091  
[www.amideast.org](http://www.amideast.org)

## EUROPE, East/West

CITO Group  
P.O. Box 1203  
6801 BE Arnhem  
Netherlands  
Telephone: 31-26-352-1577  
[www.cito.nl](http://www.cito.nl)

## GAZA

AMIDEAST  
Ahmad Abdelaziz Street  
P.O. Box 1247  
Gaza City  
Telephone: 972-2-7-286-9338  
[www.amideast.org](http://www.amideast.org)

## HONG KONG

Hong Kong Examinations  
Authority  
San Po Kong Sub-Office  
17 Tseuk Luk Street  
San Po Kong  
Kowloon, Hong Kong  
Telephone: 852-2328-0061, ext. 365  
[www.hkea.edu.hk](http://www.hkea.edu.hk)

## INDIA/BHUTAN

Institute of Psychological and  
Educational Measurement  
119/25-A Mahatma Gandhi Marg  
Allahabad, 211001, U.P. India  
Telephone: 91-532-624881  
or 624988  
[www.ipem.org](http://www.ipem.org)

## INDONESIA

International Education Foundation (IEF)  
Menara Imperium, 28th Floor, Suite B  
Metropolitan Kuningan  
Superblok, Kav. 1  
Jl. H.R. Rasuna Said  
Jakarta Selatan 12980  
Indonesia  
Telephone: 62-21-8317304 (hunting)  
[www.iie.org/iie/ief/](http://www.iie.org/iie/ief/)

## JAPAN

Council on International Educa-  
tional Exchange  
TOEFL Division  
Cosmos Aoyama B1  
5-53-67 Jingumae, Shibuya-ku  
Tokyo 150-8355, Japan  
Telephone: (813) 5467-5520

## JERUSALEM

AMIDEAST  
Nabulsi Bldg., 1st Floor  
Corner of Road #1 and Anata Road  
P.O. Box 19665  
Shu'fat, Jerusalem  
Telephone: 972-2-581-1962  
[www.amideast.org](http://www.amideast.org)

## JORDAN

AMIDEAST  
1 Akram Rashid, Um As-Summaq  
P.O. Box 1249  
Amman, 11118 Jordan  
Telephone: 962-6-581-0930  
[www.amideast.org](http://www.amideast.org)

## KOREA

Korean-American Educational  
Commission (KAEC)  
M.P.O. Box 112  
Seoul 121-600, Korea  
Telephone: 02-3275-4000  
[www.fulbright.or.kr](http://www.fulbright.or.kr)

## KUWAIT

AMIDEAST  
Yousef Al-Qenai Street  
Bldg. 15, First Floor  
Salmiya, Kuwait  
mail: P.O. Box 44818  
Hawalli 32063, Kuwait  
Telephone: 965-575-0670  
[www.amideast.org](http://www.amideast.org)

## LEBANON

AMIDEAST  
Bazerkan Bldg., Nejme Square  
1st Floor  
Riad El Solh  
Beirut, 2011 3302 Lebanon  
[www.amideast.org](http://www.amideast.org)

## MALAYSIA/SINGAPORE

MACEE  
Testing Services  
8th Floor Menara John Hancock  
Jalan Gelenggang  
Damansara Heights  
50490 Kuala Lumpur, Malaysia  
Telephone: 6-03-253-8107  
[www.macee.org.my/](http://www.macee.org.my/)

## MEXICO

Institute of International Education  
Londres 16, 2nd Floor  
Colonia Juarez, D.F., Mexico  
Telephone: 525-209-9100,  
ext. 3500, 3510, 4511  
[www.iie.org/latinamerica/](http://www.iie.org/latinamerica/)

## MOROCCO

AMIDEAST  
15, rue Jabal El Ayachi, Agdal  
Rabat, Morocco  
Telephone: 212-3-767-5081  
[www.amideast.org](http://www.amideast.org)

## PEOPLE'S REPUBLIC OF CHINA

China International Examinations  
Coordination Bureau  
167 Haidian Road  
Haidian District  
Beijing 100080  
People's Republic of China  
Telephone: 86 (10) 6251-3994  
[www.neea.edu.cn](http://www.neea.edu.cn)

## SYRIA

AMIDEAST  
Wahab Bin Saad Street  
P.O. Box 2313  
Damascus, Syria  
Telephone: 963-11-333-2804  
[www.amideast.org](http://www.amideast.org)

## TAIWAN

The Language Training & Testing  
Center  
P.O. Box 23-41  
Taipei, Taiwan 106  
Telephone: (8862) 2362-6045  
[www.lttc.ntu.edu.tw](http://www.lttc.ntu.edu.tw)

## THAILAND, CAMBODIA, AND LAOS

Institute of International Education  
G.P.O. Box 2050  
Bangkok 10501, Thailand  
Telephone: 66-2-639-2700  
[www.iie.org/seasia/](http://www.iie.org/seasia/)

## TUNISIA

AMIDEAST  
22, rue Al Amine Al Abassi  
BP 351 Tunis-Cite Jardins 1002  
Tunis-Belvedere, Tunisia  
Telephone: 216-1-790-559  
[www.amideast.org](http://www.amideast.org)

## UNITED ARAB EMIRATES

AMIDEAST  
c/o Higher Colleges of Technology  
Muroor Road (4th Street)  
P.O. Box 5464  
Abu Dhabi, UAE  
Telephone: 971-2-4-455-6720  
[www.amideast.org](http://www.amideast.org)

## VIETNAM

Institute of International Education  
City Gate Building  
104 Tran Hung Dao, 5th Floor  
Hanoi, Vietnam  
Telephone: (844) 822-4093  
[www.iie.org/iie/vietnam/](http://www.iie.org/iie/vietnam/)

## YEMEN

AMIDEAST  
Algiers St., #66  
P.O. Box 15508  
Sana'a, Yemen  
Telephone: 967-1-206-222  
[www.amideast.org](http://www.amideast.org)

## COMMONWEALTH OF INDEPENDENT STATES\*

Web Site Address and  
Telephone Numbers of  
ASPRIAL/AKSELS/ACET  
Offices  
[www.actr.org](http://www.actr.org)

## RUSSIA

P.O. Box 1  
Leninsky Prospect 2  
Office 530  
Russia 117049, Moscow  
Moscow – (095) 237-91-16  
(095) 247-23-21  
Novosibirsk – (3832) 34-42-93  
St. Petersburg – (812) 311-45-93  
Vladivostok – (4232) 22-37-98  
Volgograd – (8442) 36-42-85  
Ekaterinburg – (3432) 61-60-34  
**ARMENIA**, Yerevan  
(IREX Office)  
(8852) 56-14-10

## AZERBAIJAN

Baku  
(99412) 93-84-88

## BELARUS

Minsk  
(10-37517) 284-08-52, 284-11-70

## GEORGIA

Tbilisi  
(10-995-32) 93-28-99, 29-21-06

## KAZAKSTAN

Almaty  
(3272) 63-30-06, 63-20-56

## KYRGYSTAN

Bishkek  
(10-996-312) 22-18-82

## MOLDOVA

Chisinau  
(10-3732) 23-23-89, 24-80-12

## TURKMENISTAN

Ashgabat  
(993-12) [within NIS (3632)] 39-90-65  
39-90-66

## UKRAINE

Kharkiv – (38-0572)-45-62-46 (temporary)  
(38-0572)-18-56-06

Kyiv – (044) 221-31-92, 224-73-56

Lviv – (0322) 97-11-25

Odessa – (0487) 32-15-16

## UZBEKISTAN

Tashkent  
(998-712) 56-42-44  
(998-71) 152-12-81, 152-12-86

## ALL OTHER COUNTRIES AND AREAS

TOEFL Publications  
P.O. Box 6154  
Princeton, NJ 08541-6154, USA  
Telephone: 1-609-771-7100  
[www.toefl.org](http://www.toefl.org)

# To Reach TOEFL Services

## GENERAL INQUIRIES

For inquiries about TOEFL tests, services, policies, and procedures —

**Phone:** 1-609-771-7100  
(Princeton, NJ)

Monday – Friday  
8:00 a.m. – 8:00 p.m. New York time  
Phones are busiest all day on Monday.

**Mail:**

TOEFL Services  
Educational Testing Service  
PO Box 6151  
Princeton, NJ 08541-6151, USA

Include the following **exactly** as you entered them on your registration form or answer sheet: name, address, date of birth, test date, registration number, and phone number (U.S. residents only). Allow 4–6 weeks for a response.

**Fax:** 1-609-771-7500  
Registration forms **cannot** be faxed. Faxed correspondence will be handled in the same time frame as regular mail.

**Email:** [toefl@ets.org](mailto:toefl@ets.org)

## COMPUTER-BASED TESTING REGISTRATION

To schedule your testing appointment in **U.S., American Samoa, Guam, U.S. Virgin Islands, Puerto Rico, and Canada**, call **1-800-GO-TOEFL (1-800-468-6335)** or call the test center directly. See pages 44–45.

To schedule your testing appointment elsewhere, see page 46 for addresses and phone and fax numbers for the **International Regional Registration Centers (RRCs)**.

**Test Takers with Disabilities**

Refer to the center pages of the *Bulletin* before scheduling your test.

## TEST PREPARATION MATERIALS/PUBLICATIONS

**Phone:**

**1-800-446-3319**  
**1-609-771-7243** — outside the U.S. and Canada  
Monday – Friday  
8:00 a.m. – 9:00 p.m.  
Saturday  
9:00 a.m. – 4:45 p.m.

**Mail:**

TOEFL Order Services  
PO Box 6161  
Princeton, NJ 08541-6161, USA

## SCORES AND/OR ADDITIONAL SCORE REPORTS BY PHONE

**1-888-TOEFL44** — U.S., American Samoa, Guam, U.S. Virgin Islands, Puerto Rico, and Canada

**1-609-771-7267** — all other locations

**1-609-771-7714 (TTY)**

Available 6:00 a.m. to 10:00 p.m. New York time, 7 days a week.

## TEST QUESTION INQUIRIES

**Mail:**

TOEFL Test Question Inquiries  
(42-N-208)  
Educational Testing Service  
Rosedale Road  
Princeton, NJ 08541-0001, USA

**Fax:** 1-609-683-2600

You must notify the test supervisor of a problem or question before you leave the test site. You can then notify ETS (see page 42).

## TEST TAKERS WITH DISABILITIES

**Phone:** 1-609-771-7780

**TTY Number:** 1-609-771-7714

**Mail:**

TOEFL Disability Services  
Educational Testing Service  
PO Box 6054  
Princeton, NJ 08541-6054, USA

**Fax:** 1-609-771-7165

## EXPRESS COURIER DELIVERY

TOEFL Services (25-Q-310)  
Distribution and Receiving Center  
225 Phillips Boulevard  
Ewing, NJ 08628-7435, USA

## TEST CENTER COMPLAINTS

**Attention:** TOEFL Complaints  
TOEFL Services  
Educational Testing Service  
PO Box 6151  
Princeton, NJ 08541-6151, USA

**Fax:** 1-609-771-7500

For the Latest TOEFL Information

<http://www.toefl.org>



57306-03300 • WW21M5500 • Printed in U.S.A.  
I.N. 989563



# STOP!

If you have a credit card and would like to schedule an appointment now, refer to pages 6 and 7 for more information. **If you schedule your appointment by phone, you do not need to mail in this form.**

# TOEFL®

## CBT VOUCHER REQUEST FORM INSTRUCTIONS

### Completing the Form

- Complete the form accurately and clearly with the information for the person who plans to use the voucher and take the test. The form will be computer processed and whatever you enter for each item will appear on the test taker's record.
- Use a black ink pen. If you do not have one, you may use a soft lead pencil or blue ink pen. Do not use a highlighter, felt-tipped pen, or fountain pen.
- Use English letters. Omit spaces, hyphens, apostrophes, Jr. or II, etc., and avoid stray marks.
- Make your check or money order payable to ETS-TOEFL. See "Acceptable Forms of Payment" on page 5.
- Mail your completed form and payment or credit card information in the envelope provided in the center of your *Bulletin*. Use the "TOEFL CBT Voucher" label contained in the envelope, or address the envelope to:

TOEFL CBT Voucher  
Educational Testing Service  
P.O. Box 6159  
Princeton, NJ 08541-6159  
USA



## Instructions for Completing International Test Scheduling Form

Do NOT mail or fax more than once.

**IMPORTANT:** If the form is not properly filled out (contains incomplete information, unclear letters, or non-English characters), it MAY cause a delay in your registration and appointment scheduling. Please read the instructions carefully.

### Completing the Form

- Use black ink.
- The name given on the form must match the name on the identification document that will be presented at the test center.

### Payment Information

- You can fax or mail the form if you pay with a credit card or supply a voucher number.
- You must mail the form if submitting a check or other physical payment. For a list of acceptable currencies, see page 5. If your payment is not included with your form, your test appointment will not be held.

### Test Date and Center Information

**Note:** TOEFL is not given every day at all test centers. Contact your RRC for the latest information (see pages 46-53). If you are testing at a supplemental center, you must obtain an *Information Bulletin for Supplemental TOEFL Administrations* from the institution where you obtained this *Bulletin*, institutions listed on the inside back cover of this *Bulletin*, or TOEFL Services (see back cover for contact information).

- Indicate your first five date choices by month (MM) and day (DD); for example, May 21 would be listed as 05/21.
- Indicate the test center number where you want to test, and write out the name of the city where the test center is located. You may also indicate a second choice center.

### Submitting This Form

- **If mailed**, the RRC must receive the form at least three weeks prior to your first choice test date. Insert the form and the proper fee

payment in the envelope provided. Refer to the list of RRCs on pages 46-53 of the *Bulletin* for the correct mailing address. Use a mailing label provided in the envelope.

- **If faxed**, the RRC must receive the form at least seven days prior to your first choice test date. Be sure to include your credit card information. Fax it to the appropriate RRC (see pages 46-53 in the *Bulletin* for fax numbers).

### Scheduling Process

- When scheduling your appointment, Prometric will try to schedule your first choice date, then second, third, fourth, or fifth choice in chronological order at your first choice test center. If you decide to select a second choice test center, Prometric will then try to schedule your first choice, then second, third, fourth, or fifth choice at your second choice center. If none of the dates are available, Prometric will try to schedule you for a day closest to your choices.
- If you have a problem with the appointment scheduled for you, contact your RRC.

### Retaking the Test

You may **not** take the computer-based TOEFL test more than once per calendar month.

### Confirmation Letter

**If you do not receive a confirmation of your appointment, you must call the RRC at least three business days prior to your first choice appointment. If you miss your appointment and did not call the RRC, your test fee will not be refunded.**

## Country Codes

001 Afghanistan	125 Congo Republic	251 Hungary	378 Monaco	505 Singapore
003 Albania	126 Cook Islands	255 Iceland	379 Mongolia	503 Slovakia
005 Algeria	130 Costa Rica	260 India	381 Montserrat	504 Slovenia
007 American Samoa	290 Côte d'Ivoire (Ivory Coast)	265 Indonesia	380 Morocco	506 Solomon Islands
008 Andorra	133 Croatia	270 Iran	385 Mozambique	507 Somalia
010 Angola	135 Cuba	273 Iraq	090 Myanmar (Burma)	510 South Africa
011 Anguilla	140 Cyprus	275 Ireland	388 Namibia	515 Spain
012 Antigua and Barbuda	142 Czech Republic	277 Isle of Man	386 Nauru	520 Sri Lanka
015 Argentina	150 Denmark	280 Israel	387 Nepal	525 Sudan
016 Armenia	153 Djibouti	285 Italy	390 Netherlands	527 Suriname
017 Aruba	154 Dominica, Commonwealth of	295 Jamaica	395 Netherlands Antilles	530 Swaziland
020 Australia	155 Dominican Republic	300 Japan	396 New Caledonia	535 Sweden
025 Austria	165 Ecuador	305 Jordan	405 New Zealand	540 Switzerland
029 Azerbaijan	170 Egypt	308 Kazakhstan	420 Nicaragua	545 Syria
030 Azores	175 El Salvador	310 Kenya	425 Niger	550 Tahiti
035 Bahamas	180 England	312 Kiribati	430 Nigeria	555 Taiwan
040 Bahrain	183 Equatorial Guinea	314 Korea (DPR)	433 Niue Island	556 Tajikistan
045 Bangladesh	182 Eritrea	315 Korea (ROK)	434 Northern Ireland	560 Tanzania
050 Barbados	184 Estonia	320 Kuwait	435 Norway	565 Thailand
094 Belarus	185 Ethiopia	323 Kyrgyzstan	443 Oman	567 Togo
055 Belgium	187 Faeroe Island	325 Laos	445 Pakistan	570 Tonga
056 Belize	107 Federated States of Micronesia	328 Latvia	447 Palau	575 Trinidad and Tobago
058 Benin	190 Fiji	330 Lebanon	450 Panama	580 Tunisia
060 Bermuda	195 Finland	333 Lesotho	400 Papua New Guinea	584 Turkmenistan
063 Bhutan	200 France	335 Liberia	455 Paraguay	585 Turkey
065 Bolivia	203 French Guiana	340 Libya	460 Peru	586 Turks and Caicos Islands
069 Bosnia and Herzegovina	202 French Polynesia	343 Liechtenstein	465 Philippines	587 Tuvalu
070 Botswana	204 Gabon	344 Lithuania	470 Poland	590 Uganda
075 Brazil	205 Gambia, The	345 Luxembourg	475 Portugal	589 Ukraine
077 British Virgin Islands	206 Gaza Strip	347 Macau	474 Puerto Rico	591 United Arab Emirates
081 Brunei Darussalam	208 Georgia	348 Macedonia, former Yugoslav Republic of	477 Qatar	588 United Kingdom*
085 Bulgaria	210 Germany	350 Madagascar	482 Reunion	592 United States of America
593 Burkina Faso	215 Ghana	353 Madeira Islands	483 Romania	607 US Virgin Islands
092 Burundi	220 Greece	355 Malawi	484 Russia	595 Uruguay
307 Cambodia	225 Greenland	360 Malaysia	487 Rwanda	594 Uzbekistan
095 Cameroon	227 Grenada	361 Maldives	486 St. Kitts and Nevis	596 Vanuatu
100 Canada	228 Guadeloupe	363 Mali	521 St. Lucia	597 Vatican City
106 Cape Verde	229 Guam	365 Malta	522 St. Vincent and the Grenadines	600 Venezuela
110 Cayman Islands	230 Guatemala	367 Northern Mariana Islands	488 San Marino	605 Vietnam
113 Central African Republic	233 Guinea	368 Marshall Islands	489 Sao Tome and Principe	610 Wales
114 Chad	234 Guinea-Bissau	366 Martinique	490 Saudi Arabia	611 West Bank
115 Chile	235 Guyana	369 Mauritania	495 Scotland	620 Samoa
457 China, People's Republic of	240 Haiti	370 Mauritius	497 Senegal	623 Yemen
120 Colombia	245 Honduras	375 Mexico	498 Seychelles	625 Yugoslavia
122 Comoros	250 Hong Kong	376 Moldova	500 Sierra Leone	635 Zambia
630 Congo-DRC (Formerly Zaire)				480 Zimbabwe

Use 999 for any country not listed.

Do not use this form if you plan to test in the United States, Canada, American Samoa, Guam, US Virgin Islands, and Puerto Rico.

See the back of this form for instructions. Mail or fax your completed form to the Regional Registration Center (RRC) for the country in which you plan to test (see pages 46-53). **Do not send this form to ETS.**

Please print all information clearly in English characters. **DO NOT** include accent marks or any other special characters. Use black ink to complete the form.

Number on Identification Document (e.g., passport, national certificate of citizenship, or national ID card):

First/Given Name  
(as on photo ID):

Middle Name:

Last/Family Name  
(as on photo ID):

Day Phone:

(include country and city codes)

Evening Phone:

(include country and city codes)

Birth Date (MM-DD-YYYY):

Fax Number:

Mailing Address:

City:

State/Province:

Postal Code:

Country Code for this  
Mailing Address:

(see codes on back)

Email

Address:

**NOTE:** Bank checks, personal checks, Eurochecks, and money orders must be payable to **ETS-TOEFL**. See page 5 of the *Bulletin* for acceptable currencies.

### PAYMENT TYPE (fill in one circle):

– Bank Check/Personal Check (enclosed)

– UNESCO Coupons (enclosed)

– Eurocheck – Europe only (enclosed)

– Credit Card (Provide account information below.)

– Money Order – (enclosed)

– Voucher Number:

Type of Currency: \_\_\_\_\_

Amount Enclosed: \_\_\_\_\_

Credit Card (fill in one circle):

VISA®

MasterCard®

American Express®

Account Number:

Expiration Date: (MM-YY):

Card Holder  
Name:

### Specify five dates in order of preference and test center location(s).

Month of the Year (MM): 01 - 12

1st choice

2nd choice

3rd choice

4th choice

5th choice

Day of the Month (DD): 01 - 31

for example May 21 =   -

MM - DD

MM - DD

MM - DD

MM - DD

MM - DD

First choice

Test Center Number

write city name of test center

Second choice

Test Center Number

(Optional)

write city name of test center

I hereby agree to the general conditions set forth in the 2001-02 TOEFL Information Bulletin for Computer-Based Testing, and I agree to the policies and procedures related to computerized testing, specifically those concerning test administration, payment of fees, and reporting of scores. I certify that I am the person who will take the test at the center and whose name and address appear on this form.

Signature: \_\_\_\_\_

Date: \_\_\_\_\_



# Test Takers With Disabilities

The TOEFL program is committed to serving test takers with disabilities by providing services and reasonable accommodations that are appropriate given the purpose of the test. Nonstandard testing accommodations are available for test takers who meet ETS requirements.

All requests for accommodations must be approved in accordance with TOEFL policies and procedures. Requests must be made on the Applicant's Request for Nonstandard Testing Accommodations Form except for test takers who require **only** minor modifications to the standard testing environment (e.g., wheelchair access, adjustable table, chair, or special lighting) or who have documented medical needs (e.g., diabetes, epilepsy) that necessitate taking medication or snack breaks. These test takers should submit a letter of support from a medical doctor or other qualified professional stating the nature of the disability and the modifications requested. Send the letter along with the registration form and fee to Educational Testing Service, TOEFL Disability Services, P.O. Box 6054, Princeton, NJ 08541-6054, USA.

Because of ETS's need to review documentation in order to provide appropriate accommodations, all test takers must register through TOEFL Disability Services. Standby registration is not available.

Some accommodations that can be provided are

## Computer-Based Testing

- extended testing time (All tests are timed.)
- additional or extended breaks
- test reader
- recorder/writer of answers
- sign language interpreter (for spoken directions only)

The following can be made available to those who are familiar with their use

- Kensington Trackball mouse
- HeadMaster Plus mouse
- Intellikeys keyboard
- ZOOMTEXT

Before requesting nonstandard testing accommodations, you may want to contact the school or fellowship sponsor to which you are applying to ask if it is willing to waive the TOEFL requirement and consider your application based on other information.

## What To Include in Your Request

All requests for testing accommodations must be reviewed and approved prior to scheduling your test. Submit all materials together or your registration will be returned to you unprocessed, which may cause your test date to be delayed.

Your request must include the following:

1. A completed CBT Voucher Request Form (if testing in United States, Canada, Puerto Rico, US Virgin Islands, Guam, or American Samoa) or International Test Scheduling Form (if testing outside the United States, Canada, Puerto Rico, US Virgin Islands, Guam, and American Samoa) and the proper fee(s).

### AND

2. A completed Applicant's Request for Nonstandard Testing Accommodations Form (center of *Bulletin*).
- All applicants must complete Part I — Applicant Information and sign the Verification Statement.
  - All applicants must complete Part II — Testing Accommodations Requested.

**NOTE:** If you were approved by ETS after July 1, 2000, for the identical testing accommodations you are now requesting, complete Part III (see section on reregistration on the next page).

- Submit Part IV if you currently receive or have received accommodations at your college/university or place of employment; have documentation on file that meets the **ETS documentation criteria**; and if you are requesting only those accommodations specified in Part II of the Applicant's Request form.

**NOTE:** Only an authorized person in the office of student disability services at your academic institution, a human resources counselor at your place of employment, or a representative of a local Vocational Rehabilitation office may complete and sign Part IV — Certification of Eligibility.

- You **must** submit documentation in support of your request directly to ETS if you
  - are requesting any accommodation that is not on the list of available accommodations specified on Part II; or
  - are requesting additional or different accommodations from those previously approved by ETS; or
  - are requesting more than 100% (double-time) testing time; or
  - have not previously received the testing accommodations you are requesting; or
  - were diagnosed with a disability within the last 12 months.

The documentation must, at a minimum, meet the following criteria:

### ETS Documentation Criteria

Documentation on file for the applicant **must**

- **clearly state the diagnosed disability**
- **describe the functional limitations** resulting from the disability
- **be current**, within the last five years for LD, last six months for psychiatric disabilities, or last three years for all other disabilities (does not apply to physical or sensory disabilities of a permanent or unchanging nature)
- **include complete educational, developmental, and medical history** relevant to the disability for which testing accommodations are being requested
- **include a list of all test instruments** used in the evaluation report and relevant subtest scores used to document the stated disability (does not apply to physical or sensory disabilities of a permanent or unchanging nature)
- **describe the specific accommodations requested**
- **state why the disability qualifies the applicant for the testing accommodations requested**
- **be typed or printed on official letterhead and signed** by an evaluator qualified to make the diagnosis (include information about license or certification and area of specialization)

For applicants with learning disabilities or attention-deficit/hyperactivity disorder, more specific information regarding documentation requirements may be obtained by requesting a copy of the “ETS Policy Statement for Documentation of a Learning Disability in Adolescents and Adults” or the “ETS Policy Statement for Documentation of Attention-Deficit/Hyperactivity Disorder in Adolescents and Adults.” These publications are also available on the ETS Web site at [www.ets.org/disability.html](http://www.ets.org/disability.html).

## REREGISTRATION

If your request for accommodations has been approved by ETS since July 1, 2000, and your documentation is still current, you may request the same nonstandard testing accommodations for any test (GMAT, GRE, PRAXIS or TOEFL) during the 2001-02 testing year. To reregister, submit a registration form, appropriate fees, and Parts I, II and III **only** of the Applicant’s Request Form for Nonstandard Testing Accommodations. Be sure to indicate the previous test name and test date.

**NOTE:** If you are registering for a different test, the same accommodations will be granted if they are appropriate for that test.

## If Your Request Is Approved

**For applicants in the United States, Canada, American Samoa, Guam, US Virgin Islands, and Puerto Rico**

ETS will send you a letter confirming the accommodations that have been approved for you. **Do not call to schedule a test date until you receive this information.** Once you receive your voucher number and letter, call the phone number provided to schedule an appointment. Be prepared to provide the voucher number and the information contained in your letter. **Allow approximately three weeks from the time your request has been received at ETS to receive your authorization.**

**For applicants in all areas OUTSIDE the United States, Canada, American Samoa, Guam, US Virgin Islands, and Puerto Rico**

When your accommodations have been approved, you will receive a confirmation letter and voucher number from ETS. The letter will also provide the address and phone number of the Prometric Regional Registration Center you must contact to schedule your testing appointment. **Allow approximately three weeks from the time your request has been received at ETS to receive your authorization.**

### Mailing Addresses and Telephone Numbers

Educational Testing Service  
TOEFL Disability Services  
P.O. Box 6054  
Princeton, NJ 08541-6054, USA  
1-609-771-7780  
1-609-771-7714 (TTY for hearing impaired only)  
Fax 1-609-771-7165

## SCORING AND REPORTING

Because nonstandard test administrations are conducted under varying conditions and for only a small number of test takers, the degree of comparability of the resulting scores with those achieved under standard conditions is not always known. When an approved testing accommodation affects a test construct that is measured, a statement is included with the score report indicating that the test was taken under nonstandard conditions. In interpreting results, score recipients are reminded that test scores should be considered only one part of an applicant’s record.

# TOEFL®

## APPLICANT'S REQUEST FOR NONSTANDARD COMPUTER-BASED TESTING ACCOMMODATIONS

This form must accompany your registration and test fees in one mailing.

Educational Testing Service (ETS) is committed to serving the needs of test takers with disabilities. All requests for testing accommodations are subject to approval by ETS, and must meet ETS's documentation criteria. We reserve the right to request and review the documentation that supports any request for accommodations.

### ETS Documentation Criteria

For more detailed information including ETS's policy statements about LD, ADHD, and psychiatric disabilities, please see <http://www.ets.org/disability.html>.

Documentation on file for the applicant **must**

- **clearly state the diagnosed disability**
- **describe the functional limitations** resulting from the disability
- **be current**, within the last five years for LD, last six months for psychiatric disabilities, or last three years for all other disabilities (does not apply to physical or sensory disabilities of a permanent or unchanging nature)
- **include complete educational, developmental, and medical history** relevant to the disability for which testing accommodations are being requested
- **include a list of all test instruments** used in the evaluation report and relevant subtest scores used to document the stated disability (does not apply to physical or sensory disabilities of a permanent or unchanging nature)
- **describe the specific accommodations requested**
- **state why the disability qualifies the applicant for the testing accommodations requested**
- **be typed or printed on official letterhead** and **signed** by an evaluator qualified to make the diagnosis (include information about license or certification and area of specialization)

### INSTRUCTIONS

Part I and Part II — Required of all applicants

Part III — Required if reregistering and requesting identical testing accommodations already approved by ETS

Part IV — Required if requesting testing accommodations that you currently receive at school or place of employment

- 1) All applicants **must** submit Part I and Part II to request testing accommodations for the TOEFL test.
- 2) Submit Part III **only** if you are reregistering for the identical accommodations that were approved for you by ETS since July 1, 2000, based upon a Certification of Eligibility or documentation review. If you are taking a different ETS test, the same accommodations will be granted if they are appropriate for that test. You may not use Part III if you are reregistering and you want additional or different accommodations from those that were previously approved by ETS.
- 3) Submit Part IV **only** if you currently receive or have received in the past accommodations at your college/university or place of employment and you are requesting only the accommodations listed on Part II. An authorized person must complete and sign Part IV on your behalf.
- 4) You **must** submit documentation in support of your request directly to ETS if you
  - are requesting any accommodation that is not on the list of available accommodations specified on Part II; or
  - are requesting additional or different accommodations from those previously approved by ETS; or
  - are requesting more than 100% (double-time) testing; or
  - have not previously received the testing accommodations you are requesting; or
  - were diagnosed with a disability within the last 12 months.



**PART I - APPLICANT INFORMATION**

Applicant's name: \_\_\_\_\_  
Last (please print) First M.I.

Date of birth: \_\_\_\_\_ Sex: \_\_\_\_\_ Male \_\_\_\_\_ Female

Day phone (Voice/TTY): \_\_\_\_\_ Evening phone (Voice/TTY): \_\_\_\_\_

Fax: \_\_\_\_\_ Email address: \_\_\_\_\_

Nature of your disability (Check all that apply.):

- 1 ADD/ADHD
- 2 Learning disability
- 3 Blind
- 4 Visually impaired
- 5 Deaf
- 6 Hard of hearing
- 7 Physical disability (Describe): \_\_\_\_\_
- 8 Psychiatric disability (Describe): \_\_\_\_\_
- 9 Other (Describe): \_\_\_\_\_

When was your disability first diagnosed? \_\_\_\_\_ / \_\_\_\_\_  
Month Year

Date of professional's most recent evaluation: \_\_\_\_\_ / \_\_\_\_\_  
Month Year

**Verification Statement To Be Signed By Applicant**

I attest to the fact that the information recorded on this application is true and if this application is not sufficient, I give permission to release to ETS a copy of any pertinent information required to establish the need for the accommodation(s) requested herein. If I am requesting the use of ZOOMTEXT or other assistive device(s), I am familiar with their use.

I understand that all information that is necessary to process this application must be available to ETS sufficiently in advance of the test administration date to provide time to evaluate and process my request for accommodations. I acknowledge that ETS reserves the right to make final determination as to whether any requested accommodation is warranted and appropriate.

If I am submitting a Certification of Eligibility (Part IV), I acknowledge that my request for accommodation(s) will not be processed if I alter or revise Part IV in any way after the appropriate official has completed it. I understand that ETS does not waive its right to ask the person who completes Part IV on my behalf to submit the supporting documentation, if necessary, either before or after the test administration date. I authorize any person completing Part IV on my behalf to release this information to ETS upon request. I also understand that the documentation in support of my request for accommodations supersedes any information contained in the Certification of Eligibility.

I acknowledge that any information will be used for research purposes only, and that in no case will any individual be identified by name in research studies, and that the information will be protected by the terms of ETS's Confidentiality of Data Policy.

I further understand that ETS reserves the right to withhold or cancel my scores if it is subsequently determined that in ETS's judgment, any information presented in this application or supporting documentation is either questionable or inaccurate.

\_\_\_\_\_  
Signature of Applicant

\_\_\_\_\_  
Date

Keep a copy of this completed form for your records.

Applicant's Name: \_\_\_\_\_  
Last (please print) First M.I.

**PART II - TESTING ACCOMMODATIONS REQUESTED**

**Requested accommodations must be supported by documentation that meets ETS's documentation criteria. All requests for testing accommodations are subject to approval by ETS. Read "Test Takers with Disabilities" in the center pages of this TOEFL *Bulletin* for information concerning documentation requirements.**

**TESTING ACCOMMODATIONS REQUESTED**

**COMPUTER-BASED TESTING ADMINISTRATION** (Check all that apply.)

**Test Format — TOEFL**

- Regular format
- ZOOMTEXT

**Assistive Devices**

- Kensington Trackball mouse
- HeadMaster Plus mouse
- Intellikeys keyboard
- Other: \_\_\_\_\_

**Extended Testing Time** (NOTE: All tests are timed.)

- 50% (time and one-half)
- 100% (double time)
- Other: \_\_\_\_\_

**Note:** If you are requesting more than 100% extended testing time, you must submit documentation directly to ETS for review.

**Assistance**

- Reader
- Recorder/writer of answers
- Sign language interpreter (for spoken directions only)\*
- Oral interpreter (for spoken directions only)\*
- Wheelchair access
- Other: \_\_\_\_\_

*\*Only applicants who are deaf or hard of hearing.*

**Additional Rest Breaks**

- 1 additional break
- 2 additional breaks
- Breaks as needed (Specify) \_\_\_\_\_

**Other Accommodations** (Describe) \_\_\_\_\_

\_\_\_\_\_  
\_\_\_\_\_

**PART III - REREGISTRATION FOR SAME ACCOMMODATIONS**

I am requesting accommodations for the TOEFL test that are identical to those ETS has previously approved for me since July 1, 2000. My documentation is current **and** meets the ETS documentation criteria as stated on the first page of this form.

Previous Test Name: \_\_\_\_\_ Previous Test Date: \_\_\_\_\_

**NOTE: You must read and sign the Verification Statement in Part I.**

Applicant's Name: \_\_\_\_\_  
Last (please print) First M.I.

**PART IV- CERTIFICATION OF ELIGIBILITY**

**INSTRUCTIONS**

Part IV, the Certification of Eligibility, **must** be completed and signed by an authorized person in the office of student disability services at the applicant's college/university, by a Human Resources counselor at applicant's place of employment, or by an authorized representative of a local Vocational Rehabilitation office.

Submit the Certification of Eligibility **only** if

- (1) the applicant **has received accommodations** based on the stated disability at a college/university, place of employment, or in conjunction with vocational rehabilitation services, **and**
- (2) the documentation you have on file for the applicant meets the criteria set forth below.

**NOTE: A licensed and/or certified professional who diagnosed the disability may not complete Part IV.**

**ETS Documentation Checklist**

Please respond to each question below to confirm that the documentation on file meets ETS's criteria. If you answer "No" to any question, the applicant must submit documentation and their history of accommodations directly to ETS for review.

- | <b>Yes</b>               | <b>No</b>                |   |
|--------------------------|--------------------------|---|
| <input type="checkbox"/> | <input type="checkbox"/> | 1. Does the documentation on file <i>clearly state the diagnosed disability or disabilities</i> ?   |
| <input type="checkbox"/> | <input type="checkbox"/> | 2. Does the documentation <i>describe the functional limitations</i> resulting from the disability or disabilities?   |
| <input type="checkbox"/> | <input type="checkbox"/> | 3. Is the documentation <i>current?</i> (i.e., completed within the last five years for learning disabilities, the last six months for psychiatric disabilities, or the last three years for all other disabilities). <b>NOTE:</b> This requirement does not apply to physical or sensory disabilities of a permanent or unchanging nature. |
| <input type="checkbox"/> | <input type="checkbox"/> | 4. Does the documentation <i>include complete</i> educational, developmental, and medical history relevant to the disability for which testing accommodations are being requested?  |
| <input type="checkbox"/> | <input type="checkbox"/> | 5. Does the documentation include <i>evaluation dates</i> and <i>test results</i> ?   |
| <input type="checkbox"/> | <input type="checkbox"/> | 6. Does the documentation include a <i>list of all the test instruments</i> used in the evaluation report? <b>NOTE:</b> This requirement does not apply to physical or sensory disabilities of a permanent or unchanging nature.  |
| <input type="checkbox"/> | <input type="checkbox"/> | 7. Does the documentation of the disability <i>adequately support</i> the testing accommodations requested?   |
| <input type="checkbox"/> | <input type="checkbox"/> | 8. Is the documentation <i>typed or printed on official letterhead</i> and signed by an evaluator who is qualified to make the diagnosis?   |

Applicant's Name: \_\_\_\_\_  
Last (please print) First M.I.

**PART IV (continued) - CERTIFICATION OF ELIGIBILITY**

Indicate **TYPE OF ACCOMMODATIONS RECEIVED** (Check all that apply.)

**Test Format**

- Regular print
- Large print
- Braille
- Other: \_\_\_\_\_  
\_\_\_\_\_

**Assistance**

- Reader
- Writer
- Written instructions \_\_\_\_\_

- Sign language interpreter (for spoken directions only)
- Oral interpreter (for spoken directions only)
- Other: \_\_\_\_\_  
\_\_\_\_\_

**Extended Testing Time**

- 50% (time and one-half)
- 100% (double time)
- Other: \_\_\_\_\_  
\_\_\_\_\_

**Additional Rest Breaks**

- Yes
- If "Yes," specify: \_\_\_\_\_

**Other Testing Accommodations Provided** (Describe): \_\_\_\_\_  
\_\_\_\_\_  
\_\_\_\_\_

Is the applicant currently receiving these accommodations?  Yes  No

If "**Yes**," please indicate where accommodations have been provided.  college/university  place of employment

If "**No**," during what period of time were the above accommodations provided? From: \_\_\_\_\_ To: \_\_\_\_\_.

**Verification Statement**

**To be signed by an authorized person in the Office of Student Disability Services, Human Resources, or Vocational Rehabilitation.**

1. I certify that the accommodations indicated above are those that were documented as necessary and approved for the applicant.
2. I certify that I have reviewed ETS's documentation criteria (including ETS's policy statements for LD and ADHD, if applicable), and that the documentation supporting the disability or disabilities and the need for specific accommodation(s) meets those criteria and is on file in this office.
3. In the event that Educational Testing Service (ETS) requests a copy of any of the documentation cited above, I agree to send ETS, for its consideration, the complete file of documentation pertinent to establishing the need for these accommodations. I understand that the applicant authorizes the release of this information pursuant to the applicant's Verification Statement in Part I of this form.
4. I also understand that if ETS determines at any time that the applicant's documentation does not meet ETS's documentation criteria, ETS will withhold or cancel the applicant's score(s).

\_\_\_\_\_  
Signature of Authorized Person

\_\_\_\_\_  
Title

\_\_\_\_\_  
Print Name

\_\_\_\_\_  
Date

\_\_\_\_\_  
Name of Institution/Agency/Place of Employment

\_\_\_\_\_  
Telephone/TTY

\_\_\_\_\_  
Fax

\_\_\_\_\_  
Email Address