

DFCDE4M7H5B7CB:4B8H6H H:9@:CFA5HC B 7 C B16-B98 B H-G BFK B: 6H9G@DFC DWHMC: FC779H 1MB8F 5DM P@FC B1 7 HCB B 25FHC F 5G5 X -C @P B H4C11B89K F H8D DWA 4GC B C: FC779H 1MB8F DFC -4498*		I B HXCC H 9K 49 D297 + 9B B A 98GC B5F9 @ 47 -9G FC 0F 5B 7 9G F57 H4 B5H SB: 1 HCF A 57 < 1 986, H C DMB 7 9B97 A 5@ ± 310 H F 99D8 7 9B97 A 5@ ± 330		B5H9 B5A 9 *H8-R55* BG *H8-R55* BG 7 < 97 798 9B: 5DDF* 0B5H92 0B5A 92 A:: 5DDF* 0B5H92 0B5A 92 E "S" 7 C A A 9BHG		<b>FC779H; I M\$%</b>  <b>9GHC5H FB %6</b>  8 BK ; "BC" G7 5 @9. %% K 9+ <H G< 99H&C: %\$ F9J 5	
B9LH5DM I GR CB 5DDW 5HC B		B G: B C B C H 67 5 @ B FSK B:					

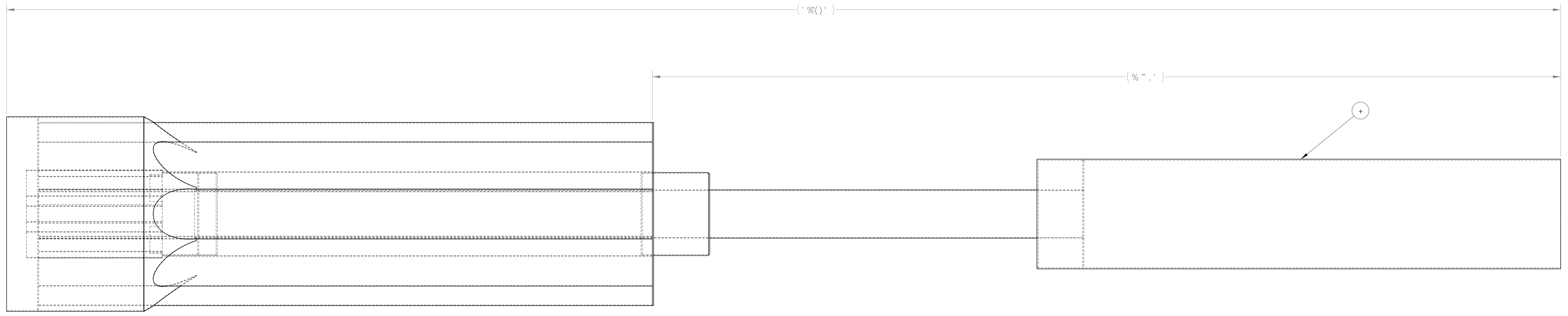

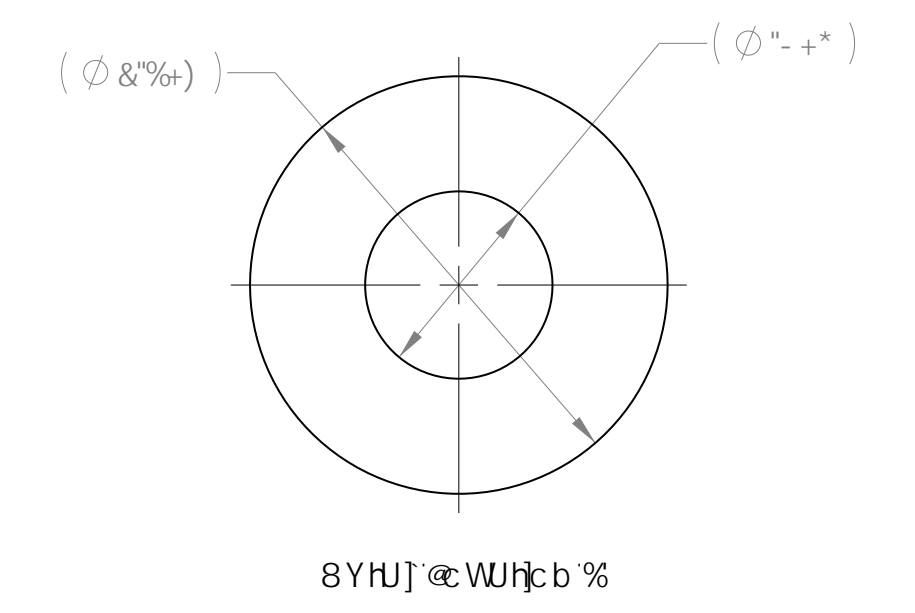

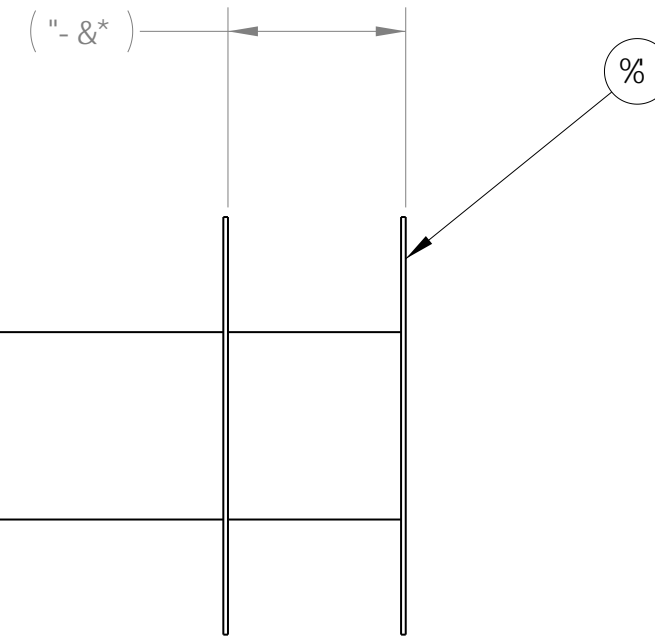
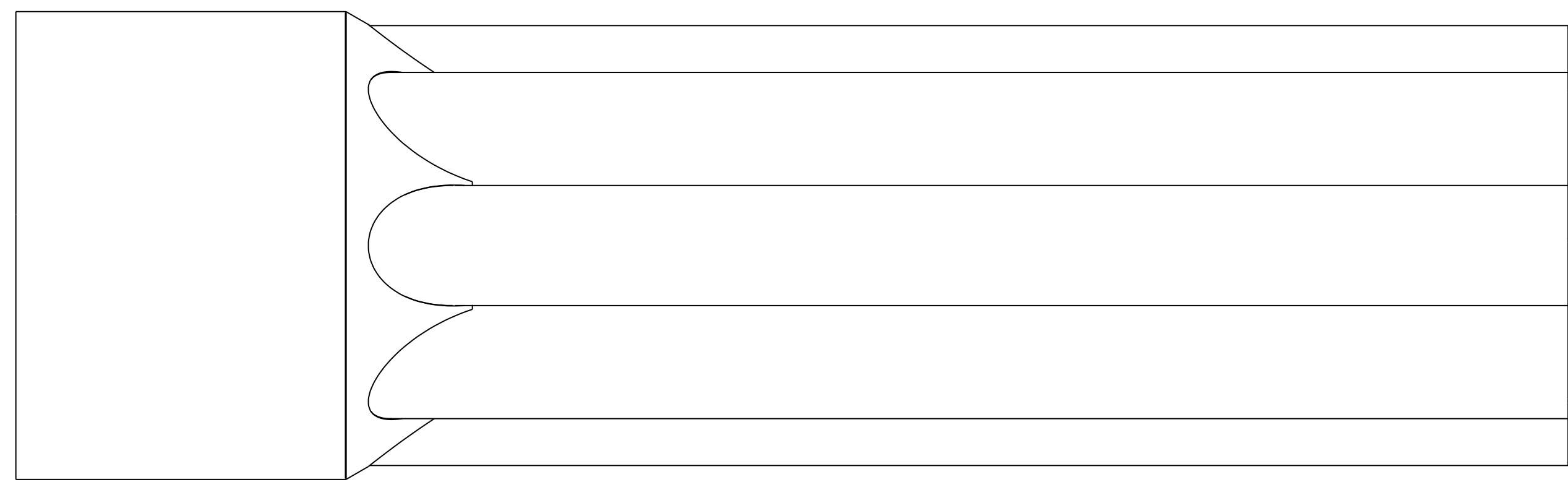

I B#KCC H 9K 49 0297 + 08 B A 90GC B519 4 07 - 90 FC 06 5B 7 9G F 57 H C B 5 9e S 5 : I H E F A 5 7 < 1 986 H C D M 7 9 B 97 A 5 0 1 3 10 H F 99 D M 7 9 B 97 A 5 0 1 3 10		B 5 1 0 B 5 A 9 B 5 K B * 0 6 + 0 5 5 B G 7 < 97 7 9 8 * 0 6 + 0 5 5 B G 0 8 : 5 0 0 0 * 0 8 5 1 0 2 0 8 5 A 9 2 A : : 5 0 0 0 * 0 8 5 1 0 2 0 8 5 A 9 2	<b>FC 7? 9H; I M \$ %</b>  9G 9G 5H FB %  G M 7 8 K ; " B C * 8 <input type="checkbox"/> <input type="checkbox"/> G 7 5 @ 9 . % % K 9 + < H G < 9 9 H ) C : % \$
B 9 L H 5 0 0 M I 0 R C B F 6 : I I I 5 0 0 0 7 5 H C B	B H E F 0 4 : 9 C A 9 H 3 H C M 5 6 7 8 : D A : S 6 G A N ( ? ) A S H F 6 0 0 F 6 : I I I B C B C H 6 7 5 0 0 0 B F 5 K 0 :	E " 5 " 0 8 5 1 0 2 0 8 5 A 9 2 7 C A A 9 8 H G	



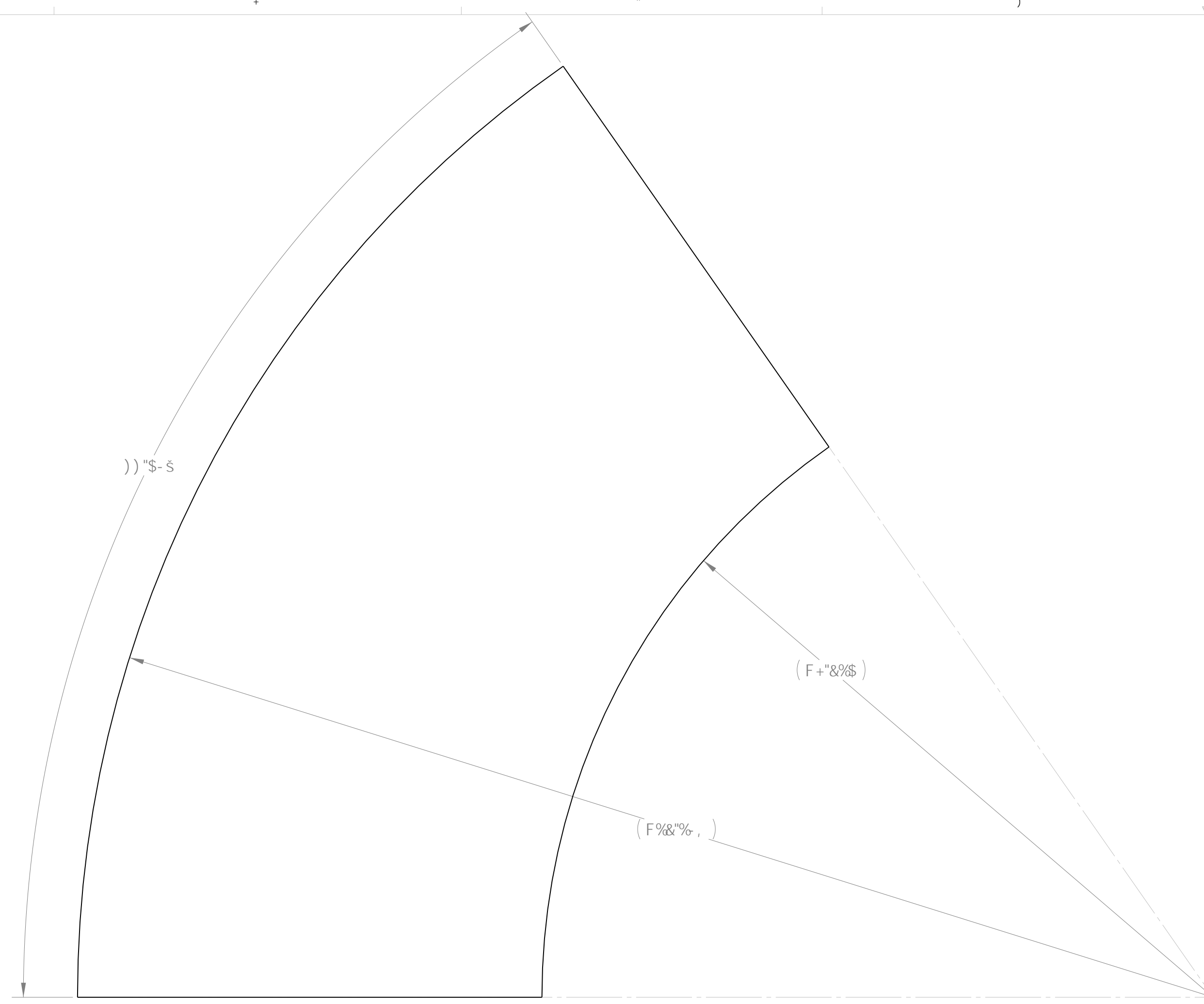

8YHUJ@WUhc b-



I B#KCC H 9K 49 0297 + 98 B A 98CC B519 47 -98 FC 08 6B 7 98 F5 7 H 6 B 5 98 S5 : 1 H 6 F A 5 7 < 1 98 H C D 6 7 9 8 9 7 A 5 8 1 5 3 0 H F 9 9 0 8 7 9 8 9 7 A 5 8 1 5 3 0		B519 B5A 9 *H+H55 BG *H+H55 BG 7 < 9 7 9 8 98 : 5 0 0 F * 0 8 5 1 9 2 0 8 5 A 9 2 A : : 5 0 0 F * 0 8 5 1 9 2 0 8 5 A 9 2	<b>FC 7?9H; I M%\$%</b>  <b>9G#GCSH FB %6</b>
B#KCC H 9K 49 0297 + 98 H 9 8 : C F A 5 H C B 7 C B 6 B 9 8 B H G B F 5 K 8 : 6 H 9 G 4 9 8 C D W I M C : F C 7 7 9 8 I M B F S 0 0 4 P A R C B I 7 H C B B 2 5 F H C F 5 5 5 X < C 4 9 B H C I 1 0 8 9 K F H 8 0 D F A 4 5 C B C : F C 7 7 9 8 I M B K 6 D F C < 4 4 9 8	B#KCC H 9K 49 0297 + 98 H 9 8 : C F A 5 H C B 7 C B 6 B 9 8 B H G B F 5 K 8 : 6 H 9 G 4 9 8 C D W I M C : F C 7 7 9 8 I M B F S 0 0 4 P A R C B I 7 H C B B 2 5 F H C F 5 5 5 X < C 4 9 B H C I 1 0 8 9 K F H 8 0 D F A 4 5 C B C : F C 7 7 9 8 I M B K 6 D F C < 4 4 9 8	B#KCC H 9K 49 0297 + 98 H 9 8 : C F A 5 H C B 7 C B 6 B 9 8 B H G B F 5 K 8 : 6 H 9 G 4 9 8 C D W I M C : F C 7 7 9 8 I M B F S 0 0 4 P A R C B I 7 H C B B 2 5 F H C F 5 5 5 X < C 4 9 B H C I 1 0 8 9 K F H 8 0 D F A 4 5 C B C : F C 7 7 9 8 I M B K 6 D F C < 4 4 9 8	B#KCC H 9K 49 0297 + 98 H 9 8 : C F A 5 H C B 7 C B 6 B 9 8 B H G B F 5 K 8 : 6 H 9 G 4 9 8 C D W I M C : F C 7 7 9 8 I M B F S 0 0 4 P A R C B I 7 H C B B 2 5 F H C F 5 5 5 X < C 4 9 B H C I 1 0 8 9 K F H 8 0 D F A 4 5 C B C : F C 7 7 9 8 I M B K 6 D F C < 4 4 9 8

8 BK ; "BC"  
 G7 5 @ 9 . % % K 9 + < H G < 9 9 H + C : % \$

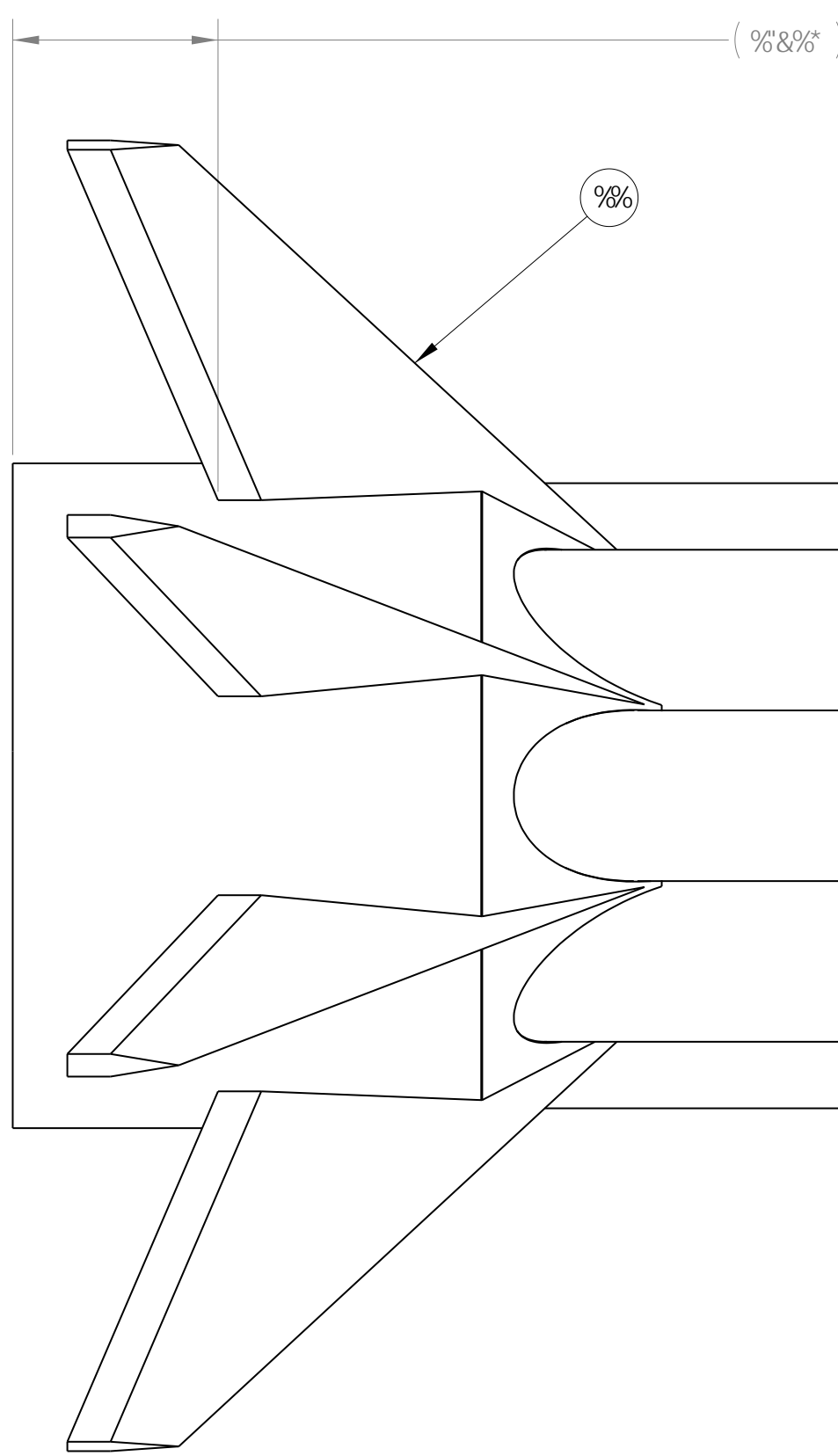
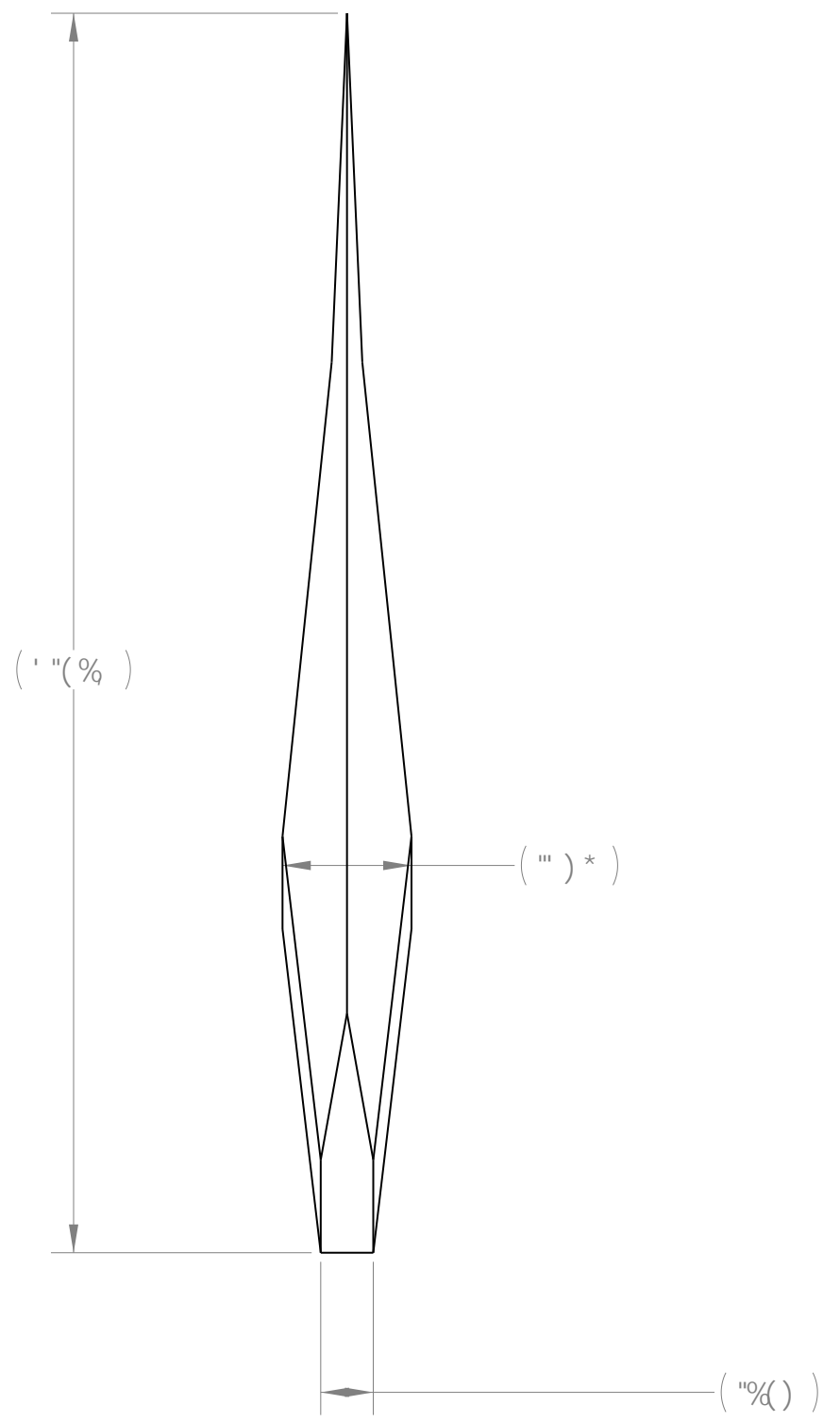
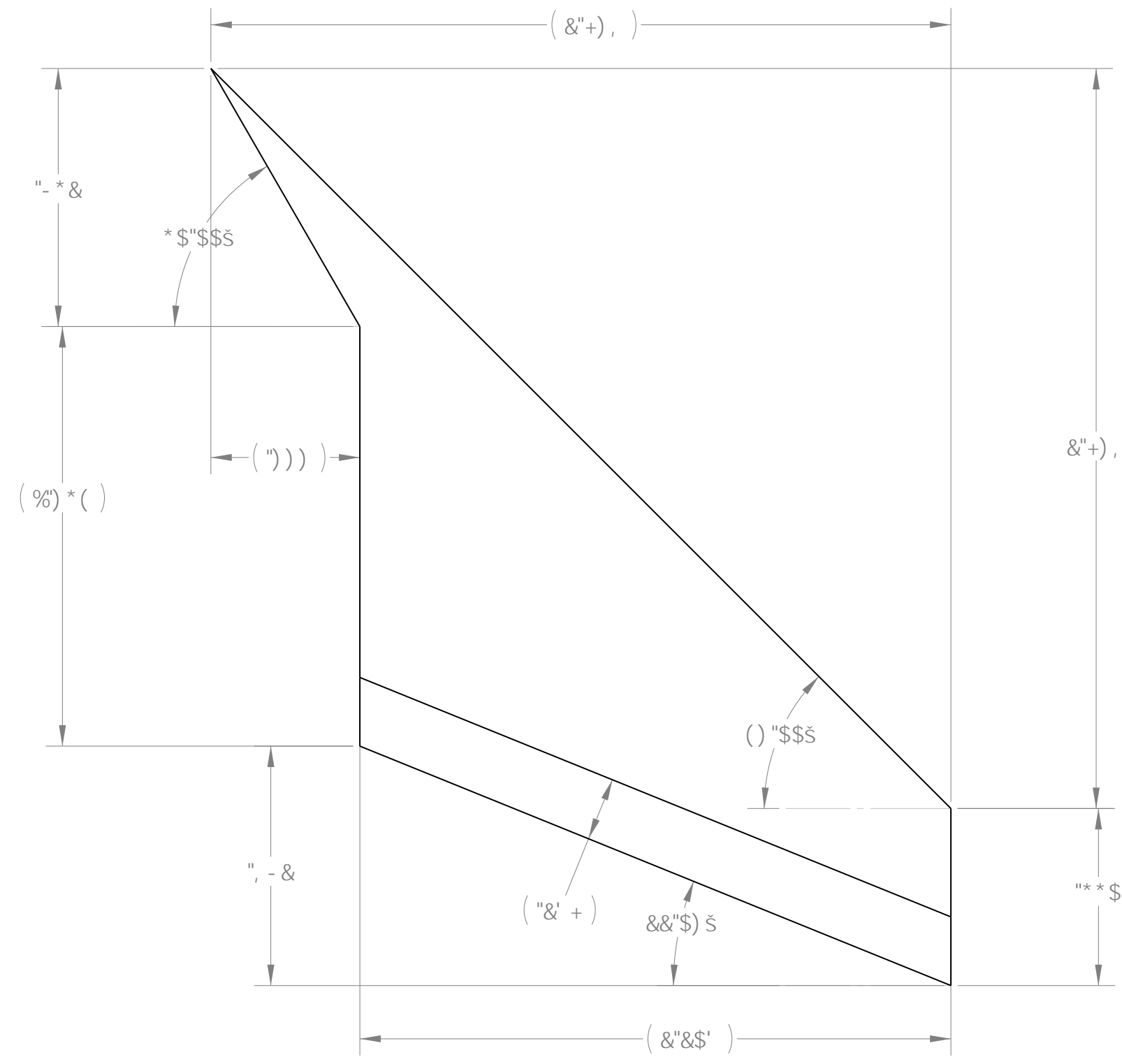
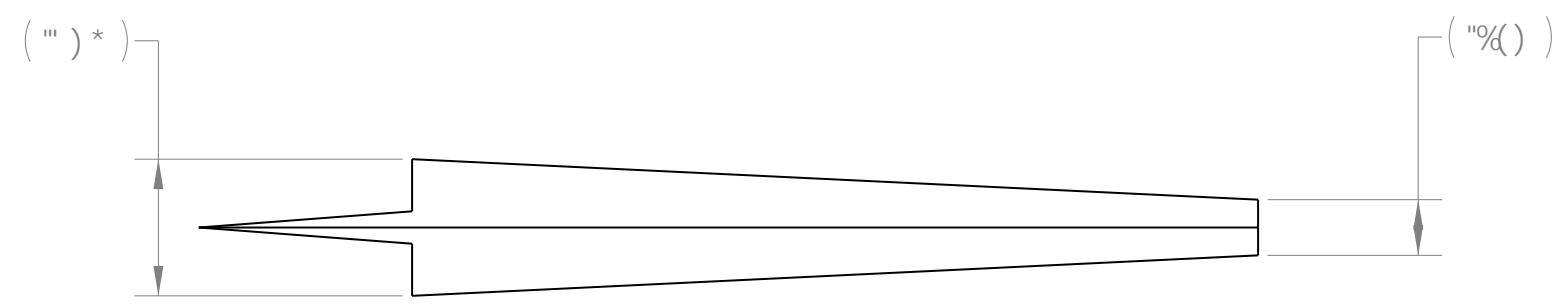
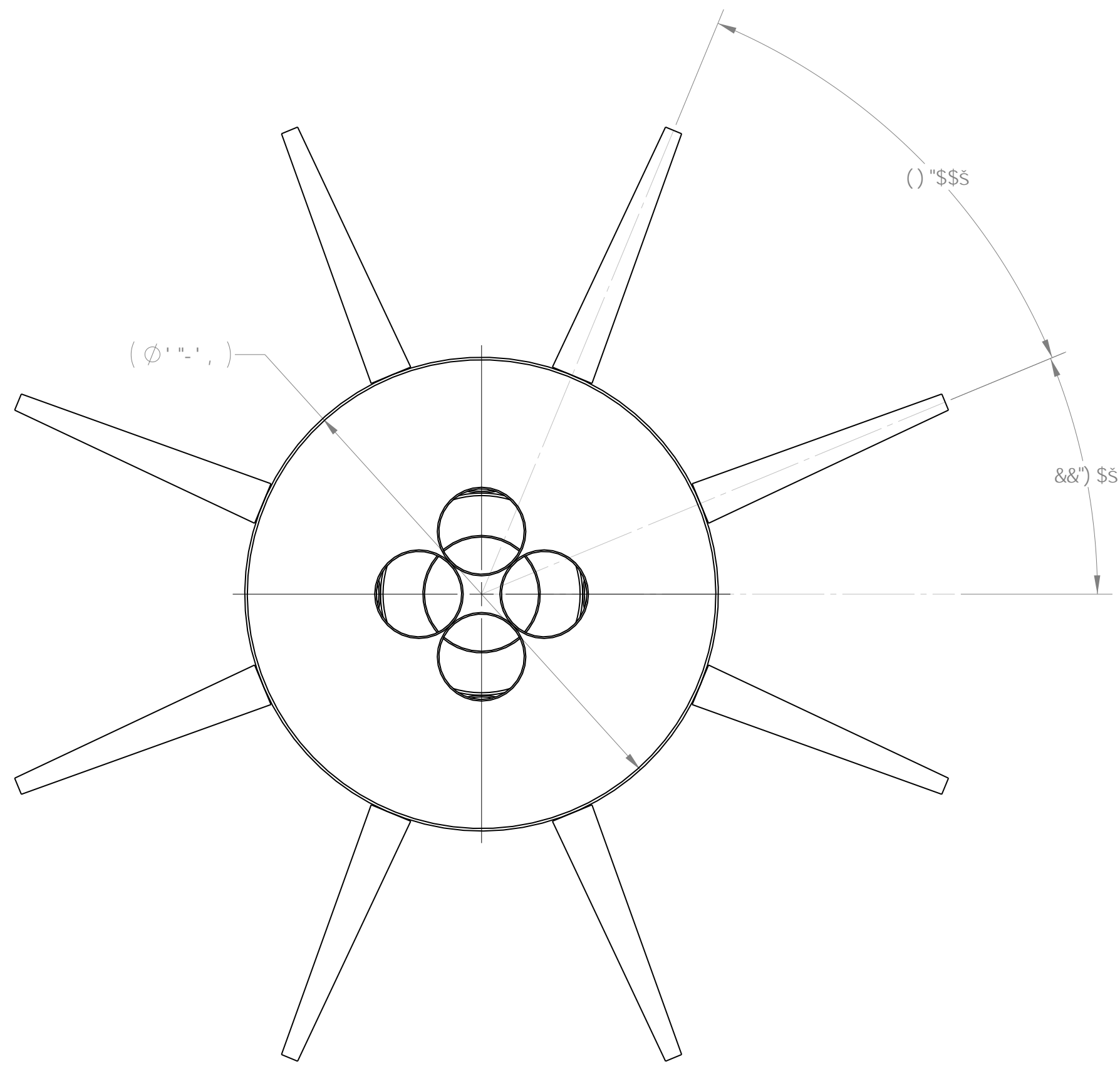

8YHJ'@WUhc b %%

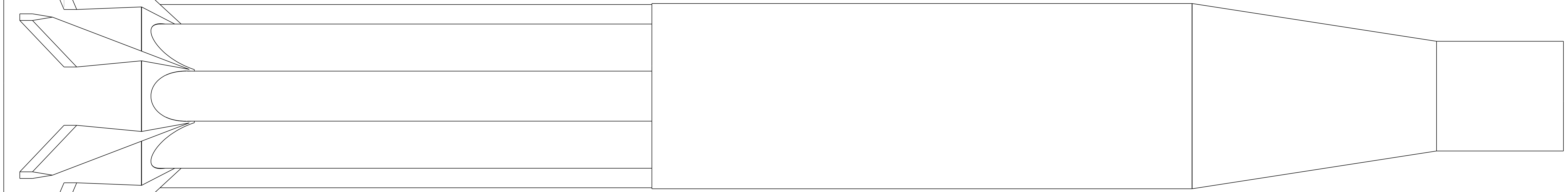

I B#KCC H'9'K 49'Q97 + 9B B A 9GCG BCS19 # 47 - 9G FC 9F 6B 7 9G F5 7 HC B5 9e S5 : I REF A 5 7 < 1 98, HC C DMB 7 9B97 A 5# ± 310 H F 99 DMB 7 9B97 A 5# ± 335		B519 B5A 9 *A#-R55' BG *A#-R55' BG 7 < 97 798 9B : 500F* 0B5192 0B5A 92 A : 500F* 0B5192 0B5A 92	<b>FC7?9H; I M%\$%</b>  <b>9G#GCSH FB %6</b>
B#KFC9H: 9CA 9FJ HC 9F 5B 7 # : DA : 5BGAH(?) A 5#R 6# III		E '5' 7 C A A 9BHG	
B#LH50DM I QR CB 500W 5HC B	B#G: III BC BCH 675#B BFSK #	8K : "BC" 8 <input type="checkbox"/> 5 G7 5 @9. %% K 9# <H G<99H, C: %\$	

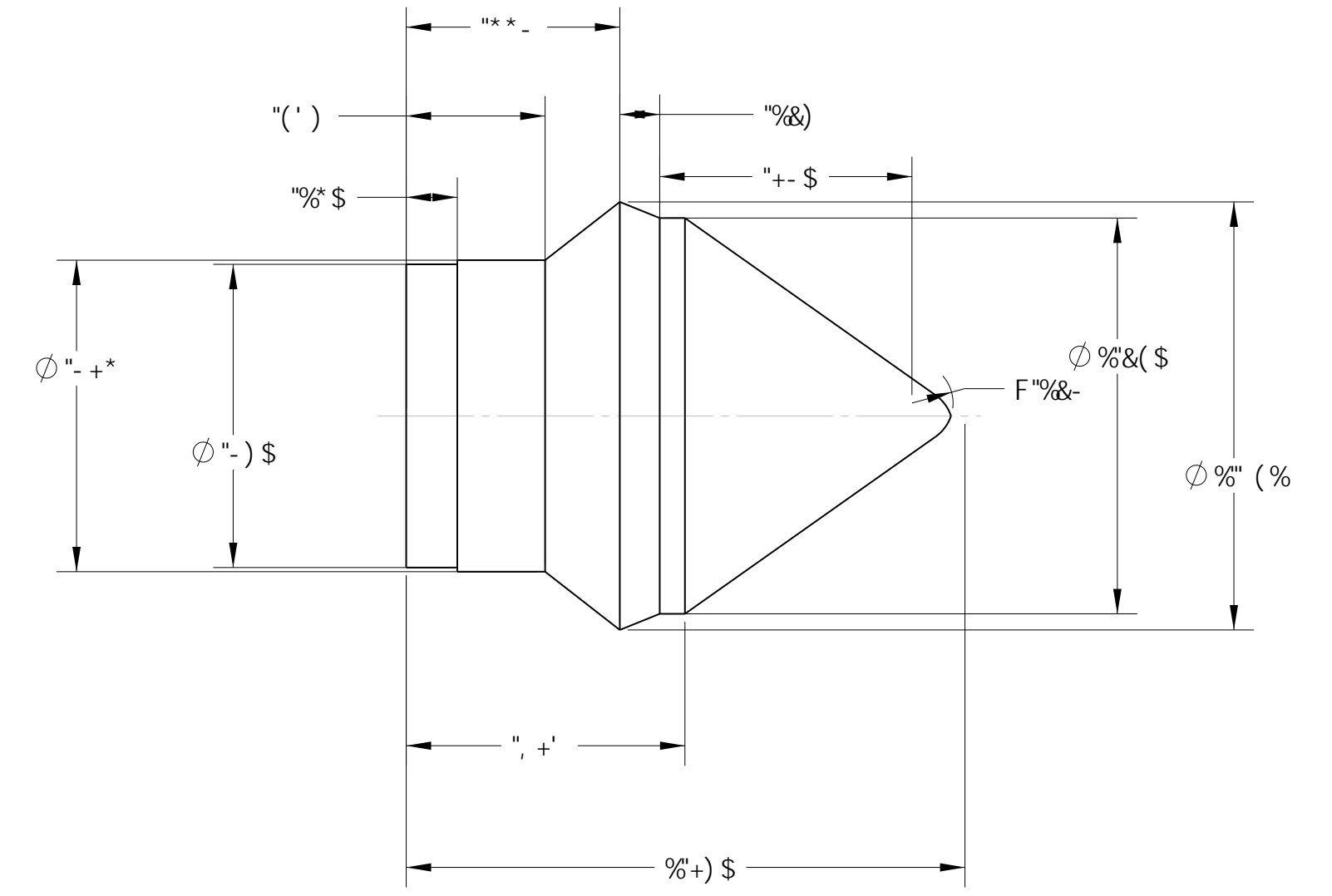
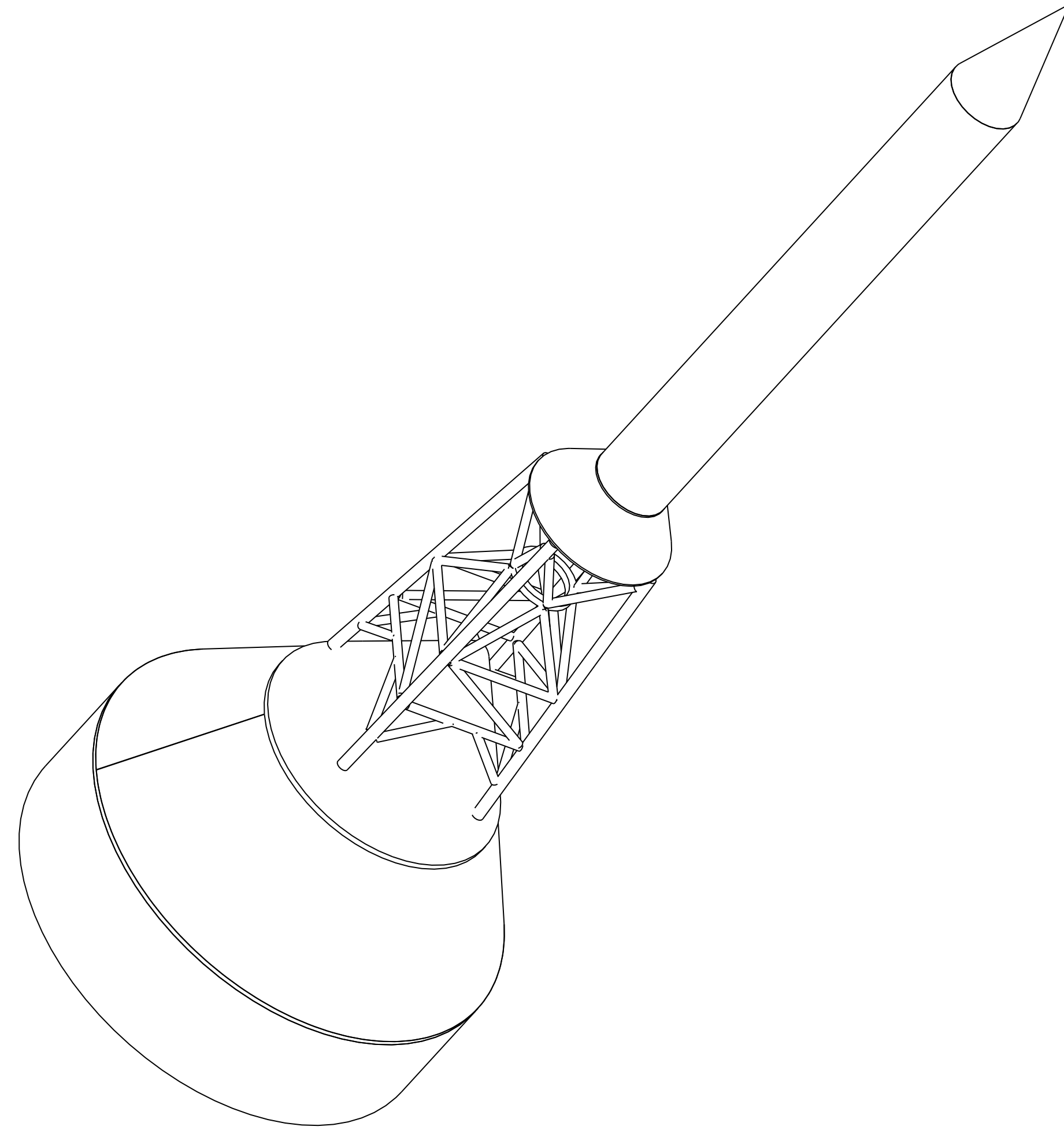
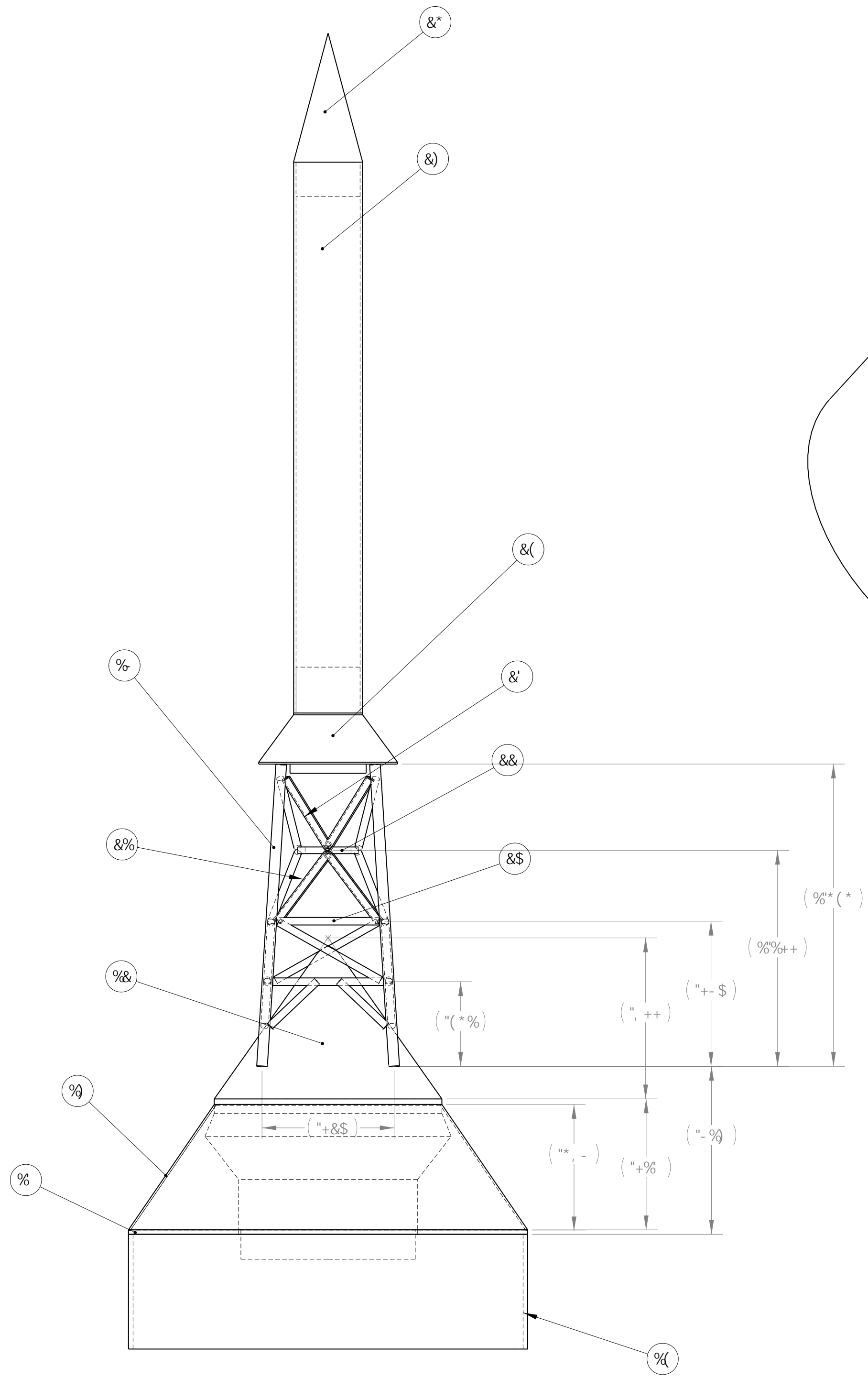

8YHUJ'@WUhc b %&

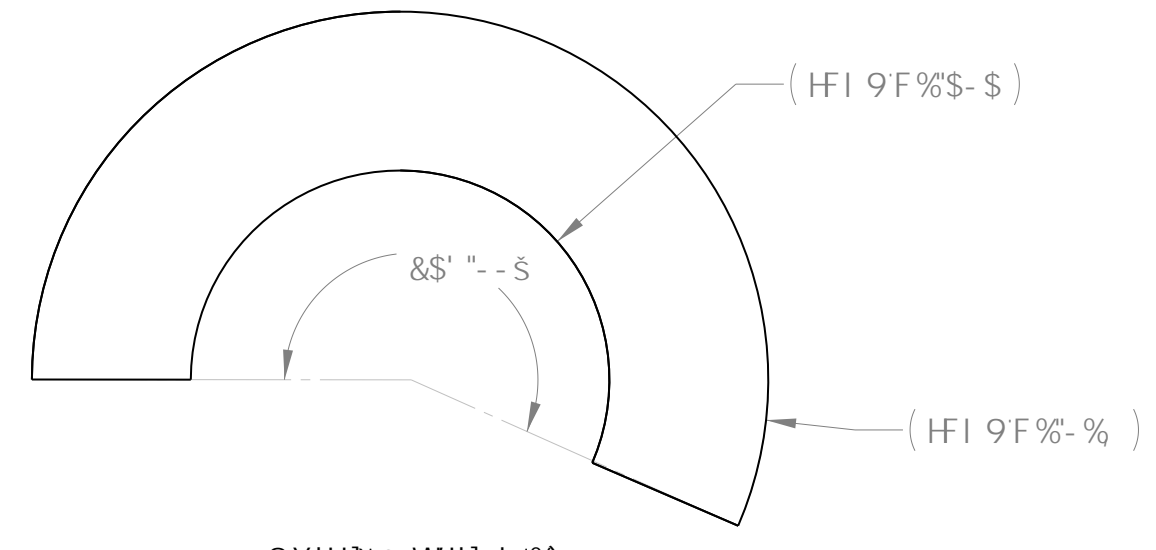

8YHUJ'@WUhc b %)

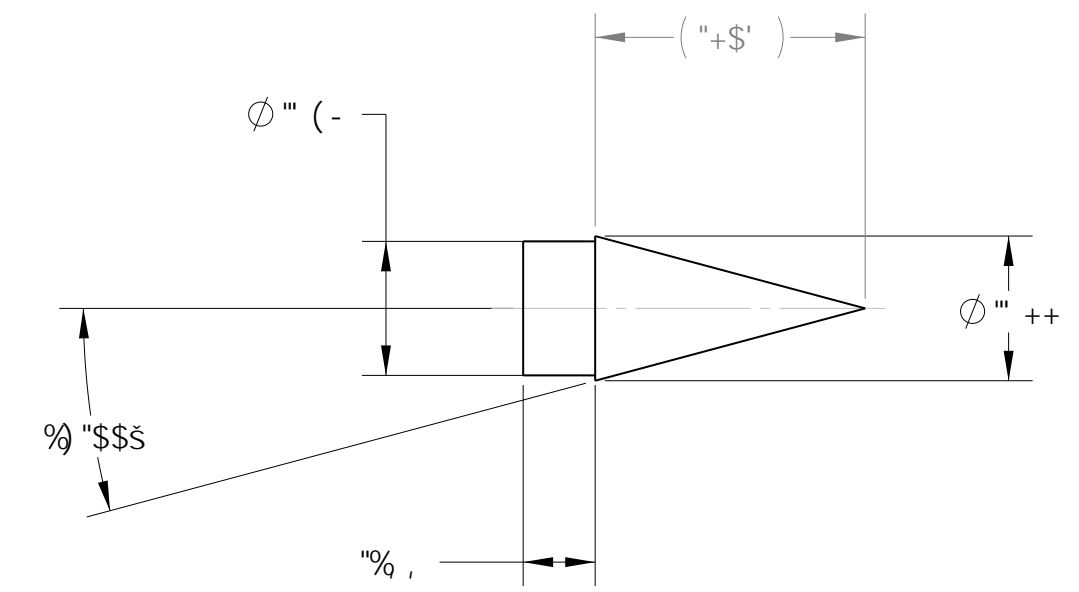

8YHUJ'@WUhc b &\*

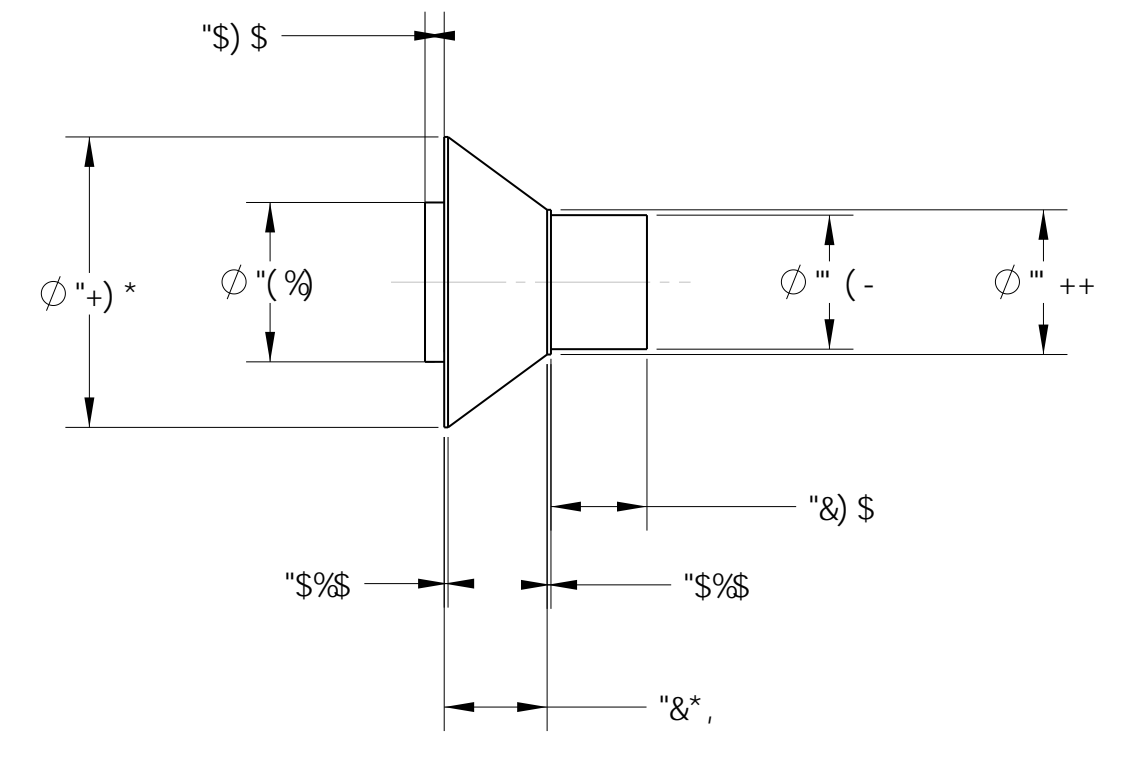

8YHUJ'@WUhc b &()

I B#KCC H 9K 49 0297 + 08 B A 90GC B519 4 07 - 90 FC 06 EB 7 90 F 57 HC B 5 90 S 5 : I H E F A 5 7 < 1 90 H C D 6 7 9 8 9 7 A 5 0 1 3 10 H F 9 9 0 8 7 9 8 9 7 A 5 0 1 3 10		B 5 1 0 * 4 6 - 1 0 5 5 B G 7 < 9 7 9 8 * 4 6 - 1 0 5 5 B G 9 8 : 5 0 0 0 * 0 8 5 1 9 2 0 8 5 1 9 2 A : : 5 0 0 0 * 0 8 5 1 9 2 0 8 5 1 9 2	B 5 A 9 B G B G 0 8 5 A 9 2 0 8 5 A 9 2 0 8 5 A 9 2	<b>FC 7 9 H ; I M \$ %</b>  9 0 H 6 C 5 H F B %  G M 7 8 K ; " B C * 8 G 7 5 @ 9 . % % K 9 + < H F 9 J 5 G < 9 9 H - C : % \$
D F C 0 6 4 6 F 1 5 8 8 7 C B : 4 8 1 6 6 H : 9 0 : C F A 5 H C B 7 C B 1 6 : B 9 0 B 1 6 G B F 5 K B : 6 1 6 9 G 4 8 F C D W 1 M C : F C 7 7 9 1 I M B 8 F 5 0 1 1 P 0 0 C B 1 7 H C B B 2 6 F H C F 5 0 5 X - C 0 4 B 1 4 C 1 1 0 4 9 K F 4 8 0 D 1 6 A 4 0 C B C : F C 7 7 9 1 I M B 8 F 5 0 1 1	B 1 4 H 5 0 0 1 I 0 0 1 C B B G : 5 0 0 0 7 5 H C B B C B C H 6 7 5 0 4 8 F 5 K B :	B H F 0 F 0 H : 9 C A 9 H 3 H C H 5 5 7 8 : D 4 : 5 6 G 4 8 1 1 A 5 1 6 6 0 B G : B C : B C H 6 7 5 0 4 8 F 5 K B :	E " 5 * 7 C A A 9 8 H G	

