

ADDING NOISE VISUALIZATION AND OTHER INTERFACE IMPROVEMENTS TO THE MEASUREMENT OF ANISOTROPY OF MAGNETIC SUSCEPTIBILITY (AMS) ON A MINISEP SYSTEM

R. Siqueira

Lab. de Paleomagnetismo - Instituto Astronômico e Geofísico (IAG) - Univ. de São Paulo (USP) - Brasil (robertsq@usp.br)

This work describes a series of efforts to increase the quality and productivity of the anisotropy of magnetic susceptibility (AMS) measuring process. The basic idea was to provide real-time visualization of both AMS and its associated noise, simultaneously freeing the user as much as possible from measurement details.

The MINISEP system measures the AMS of a rock sample by: taking its bulk (z-axis) susceptibility, measuring susceptibility variations in 3 orthogonal planes, and applying Fourier filtering, principal component analysis and field corrections to these data to finally print out the results.

The following mechanisms were added to this process: (1) direct computer access to the MINISEP signals through a parallel board; (2) noise calculation; (3) immediate graphical presentation of the results; (4) a data bank structure to keep pre- (field corrections, bulk measurements) and pos-AMS measurement information; (5) interactive site-level averaging.

The software in use since 1997 at IAG's paleomagnetism lab was written in QuickBASIC and its successful philosophy is now being extended to our other measuring systems. A Windows version is also under development.

Measuring AMS: Key Features

Belt-and-button representation. (belt = MAX-MED plan; button = MAX direction) Belt width and button size indicate the error.

Small black-and-white symbols are old measurements (errors are not saved). Dark button + light belt = prolate; light button + dark belt = oblate; both dark = 3-axial.

The system "asks" for attenuation by itself. Calibration value changes according to the sample length.

**Colecao: DB AMOSTRAS DO ESTADO DE RORAIMA.
Medindo: ANISOTROPIA**

**Atenuador= 1
Calib.= 123
Fator de calib.= 1.3275
Comprim.(amostra)= 2.2**

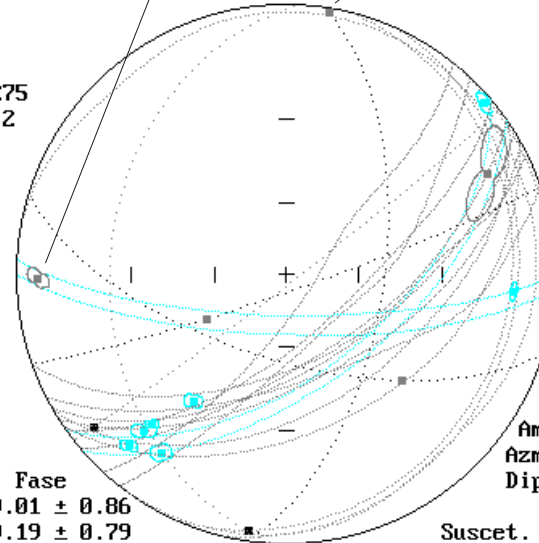
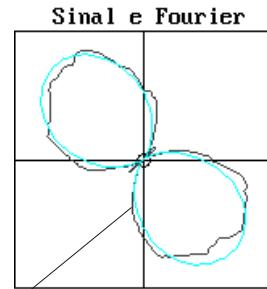

- Sitio: 814**
 328-B1[sma]
 328-C1[sma]
 328-D1[sma]
 329-A1[sma]
 *329-B1[s.a]
 *329-C1[sma]
 *329-D1[s.a]
 *329-E1[s.a]
 *329-F1[sma]
 * 330-A1[sma]
 * 330-B1[sma]
 * 330-C1[sma]
 >* 330-D1[s.a]
 * 330-E1[s..]
 * 330-F1[s..]

A pre-selection process attach a "*" to the samples you will measure. [sma] means: susceptibility, magnetization and anisotropy already on file, respectively.

**Amostra de cilindro
Azm=316 Lav.=MRN
Dip= 38 SusZ= 1463.9**

Data bank information about the sample marked ">" (the correspondent plot blinks on the equal-area diagram).

Pos.	Amplitude	Fase
1:	24.19 ± 0.69	79.01 ± 0.86
2:	37.53 ± 0.36	99.19 ± 0.79
3:	14.33 ± 0.44	100.30 ± 2.74

	Susct.	Decl.	Incl.
MAX:	1501.51	222.77	14.63
MED:	1476.60	119.08	42.19
MIN:	1462.77	327.46	44.15
MAX	----- ----- ----- -----MIN		
	----- 0.87 % -----		

128 measurements per rotation, in their respective angular positions, compose this 8-shaped image (the center refers to the local minimum).

Partial results per position. Note the error indications: they define dynamically the number of repetitions.

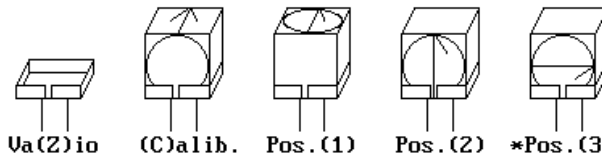

The empty holder is taken into account. A calibrating measurement adjusts automatically the sensor's amplitude and phase.

Press the highlighted key, or <ENTER> for the position marked "*". Quicker and cleaner than with a mouse.

Use these keys to move between sites (all sites are saved on the same file).

An easy way to represent the relationship between anisotropy axes (MED is movable) and the total anisotropy.

(1) Direct Access To The MINISEP Signals

It was adapted a technique used by Molspin in another of their apparatuses, the MINISPIN magnetometer: deactivating the inner processor and using a parallel interface (PIO-48 card) to connect directly the computer to the A-to-D converter and motor signals.

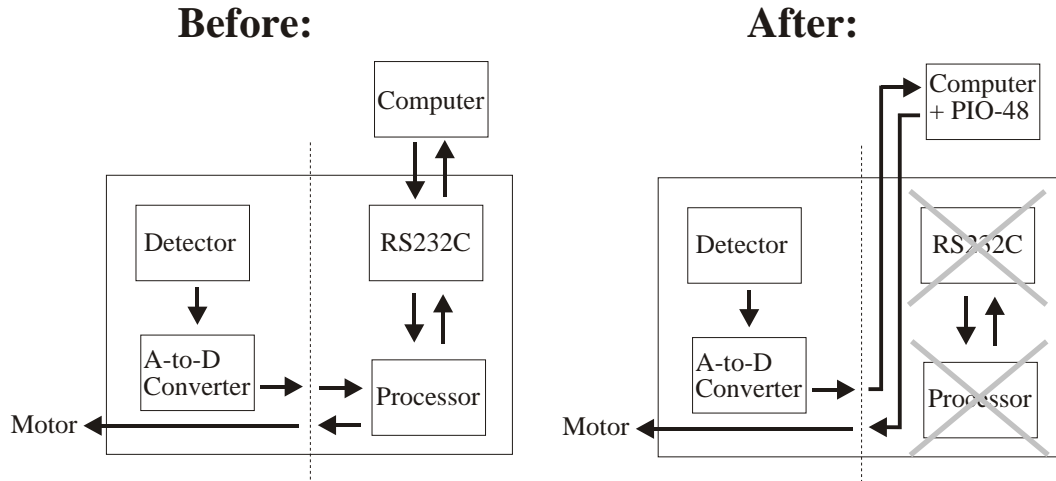

Although forbidding the use of the system in manual mode, this change was necessary because part of the original process is "hidden" inside the inner processor (data collection, Fourier filtering), what prevents any further processing (plotting, statistical treatment) of the original (raw) data.

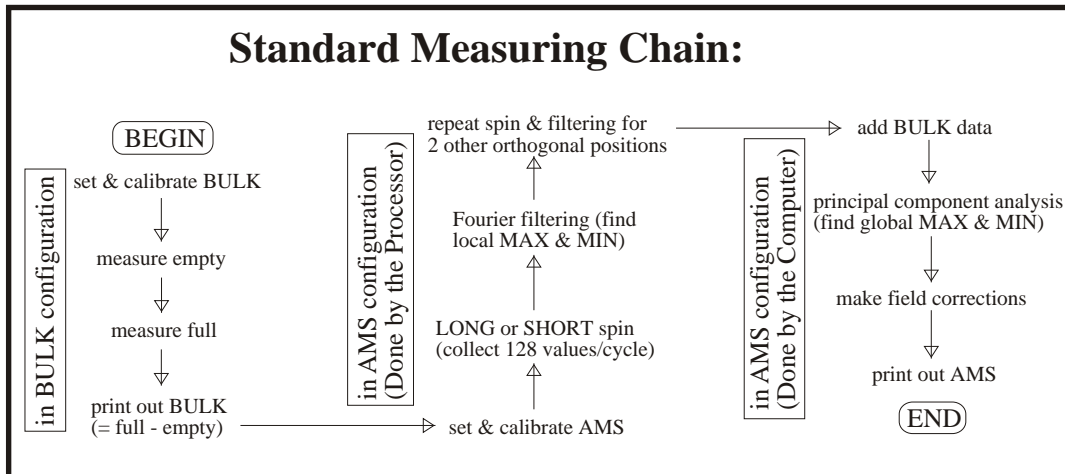

BULK Configuration:

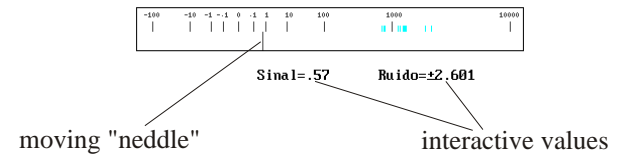

- Characteristics:
- Continuous display of both susceptibility and its noise (hundreds of values can be collected and have their average and standard deviation calculated and printed in 1/10 of a second).
- Unexpected discoveries:
- Changing the attenuation also changes the zero level (something to be taken into account);
 - It's easy to visualize how big are the drifts caused by moving the coils or the objects around them (now the BULK coils are firmly attached to the table);
 - It is not necessary to take an empty measurement for every sample when dealing with strong samples (this really speeds up things!).

AMS Configuration:

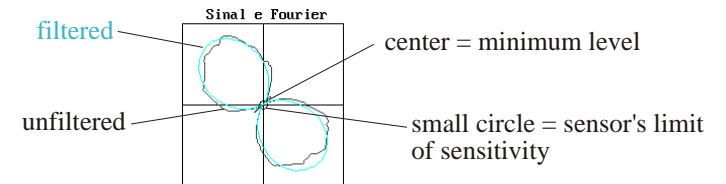

interactive values

Pos.	Amplitude	Phase
1:	24.19 ± 0.69	79.01 ± 0.86
2:	37.53 ± 0.36	99.19 ± 0.79
3:	14.33 ± 0.44	100.30 ± 2.74

- Characteristics:
- Now the sample holder can be measured and subtracted (individually for each position);
 - Dynamic selection of the number of rotations, depending on signal-to-noise ratio (before, the choice was only between a SHORT or a LONG spin);
 - Each plane can be measured on the best attenuation level;
 - Simultaneous display of filtered and unfiltered signals;
 - Error parameters can be computed.
- Unexpected discoveries:
- The spin vibration generates noise on the orthogonal coils (now a rubber layer insulates them);
 - The best noise indicator is the 8-shaped diagram itself.

(2)

Noise Calculation

(Z-axis) BULK Determination:

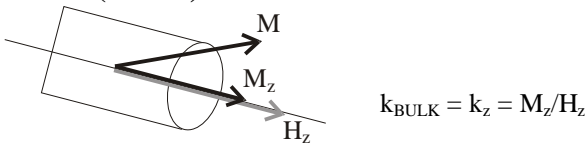

Bulk susceptibility, in our system, is proportional to the change in coil inductance (L): $k_{BULK} = C * (L_{with\ sample} - L_{empty})$.
(The constant C is obtained measuring a calibration sample.)

Associated Error:

Having a set of repeated measurements of the same L value, it is possible to obtain an approximation for its error calculating the standard deviation () for the set. Then it is enough to propagate it to k_{BULK} using simple error algebra. Please note that:

- The equivalent to the angular θ_{95} is $2*$, but we are using $1*$;
- By error algebra, even when: $L = L_{with\ sample} - L_{empty}$ we have: $err(L) = err(L_{with\ sample}) + err(L_{empty})$.

Fourier Analysis of 1 Spin:

Spinning at a frequency f, each rotation affords 128 new directional measurements, corresponding to 128 susceptibility variations to an arbitrary bias.

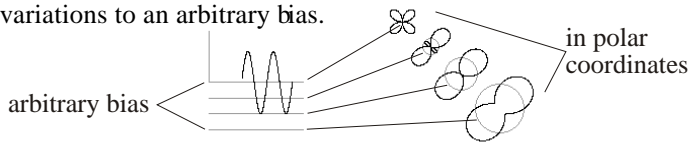

These measurements are treated as 128 samples (or better: $2*64$ samples) of a sinusoid of frequency $2*f$, the anisotropy signal. The 2 Fourier components: C_{odd} and C_{even} of this signal are then obtained convoluting (i.e. integrating together) these samples respectively with a unitary sine and a unitary cosine having the same frequency $2*f$.

For a given spin plane, the amplitude (a) and phase () of the local MAX can be calculated by:

$$a = \sqrt{C_{odd}^2 + C_{even}^2};$$

$$= \text{atan}(C_{odd}/C_{even}); \quad = /2 \text{ (due to } 2*f\text{-to-}f \text{ frequency change)}$$

Associated Error:

If the spin is composed e.g. by 40 full rotations, our universe of samples has 80 (periods) * 64 (samples per period) elements.

There are 3 possible strategies to obtain the errors:

- (1) to calculate 64 standard deviations, adopting the average of them as the noise level;
- (2) to calculate 80 pairs of Fourier components, finding the stand. dev. for each component. Amplitude and phase errors:

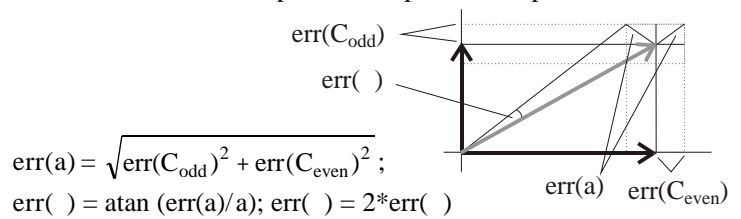

- (3) to use a hybrid of the former 2, averaging groups of 5 or 10 rotations each (as in 1) and using these partial averages to obtain the Fourier pairs (as in 2).

Strategy 2 is the implemented strategy, but strategy 3 seems better for very weak samples, when only one spin is too noisy to be significative.

AMS Tensor Determination:

Suppose the tensor given by the simmetric matrix:

$$K = \begin{pmatrix} k_{xx} & k_{xy} & k_{xz} \\ & k_{yy} & k_{yz} \\ & & k_{zz} \end{pmatrix}$$

Then: $k_{zz} = k_{BULK}$, straight.

The other elements can be calculated almost as directly from the Fourier components of the 3 orthogonal spins:

- xy-plane spin => $C_{odd} = k_{xy}; C_{even} = k_{xx} - k_{yy}$
- yz-plane spin => $C_{odd} = k_{yz}; C_{even} = k_{yy} - k_{zz}$
- zx-plane spin => $C_{odd} = k_{zx}; C_{even} = k_{zz} - k_{xx}$

Associated Error:

As far as we are satisfied in attaching 1 error to each matrix element as if they were independent scalars, it is not even necessary to calculate the amplitude and phase errors (they are only calculated to be displayed) as are the errors from the Fourier components that are used here:

$$k_{zz} = k_{BULK} \Rightarrow err(k_{zz}) = err(k_{BULK});$$

$$k_{xy} = C_{odd\ xy} \Rightarrow err(k_{xy}) = err(C_{odd\ xy});$$

$$k_{yy} = k_{zz} - C_{even\ yz} \Rightarrow err(k_{yy}) = err(k_{zz}) + err(C_{even\ yz}) \text{ etc.}$$

Note that avoiding using phase on the calculations also frees us from using the more complicate angular (Fischer) statistics.

Principal Component Analysis:

Calculating the eigenvectors and eigenvalues of tensor K gives the global MAX, MED and MIN directions (vectors) and sizes (values). (MED is used instead of INT to avoid confusion with INTensity.) The problem is stated by the expression: $K \cdot v = k \cdot v$, where we have to find the vectors v (MAX, MED and MIN) that don't change in direction when multiplied by the tensor K . Note that these vectors are allowed to change in size; the scalar multiplying factors k are the eigenvalues.

Although not linear, the process is always possible for simmetric matrices (our case) and can be deterministically implemented through the solution of a cubic equation. (The old MINISEP software used a slower numerical convergence technique.)

Associated Error:

If we represent the tensor by a closed surface, our planar measurements (spins) can be seen as "cuts" on it.

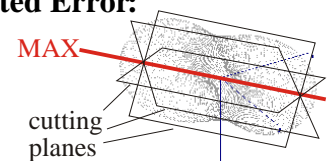

To have an idea of the errors around, say, the MAX axis, it is enough to obtain the phase error for a series of concurrent "cuts" over the MAX. It is more or less the inverse process done on the previous step, where errors from "cuts" are used to find the errors for the total tensor. Although not so straightforward as before, this can be accomplished using (again) Fourier components.

Obviously, the error around the MAX-MED plane is just a mirror of the error around the MIN axis.

(3)

Graphical Presentation

Measuring BULK:

Colecao: DB AMOSTRAS DO ESTADO DE RORAIMA.
Medindo: SUSCETIBILIDADE

Atenuador= 100
Calib.= 88
Fator de calib.= .0559
Comprim.(amostra)= 2.2

Curva de Suscetibilidade

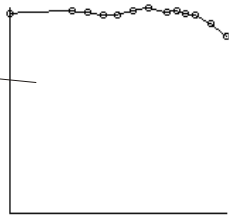

Susceptibility vs. temperature curve. Standard X vs. Y curve, but implies a data bank structure (to be able to access past measurements).

Amostra de cilindro
Etapa ant.=700C
Susc. ant.=1922.58

Mapa de Suscetibilidades Inicias

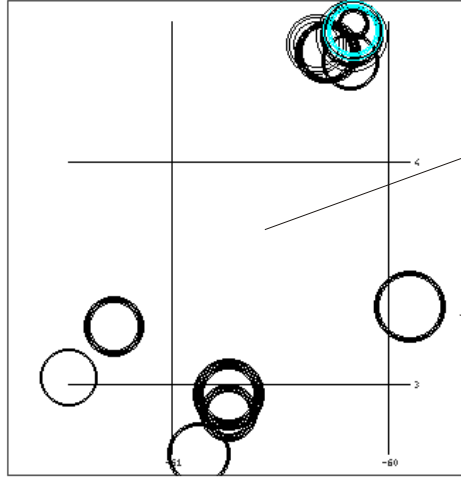

Sitio: 814

- 325-C1[sm.]
- 325-F1[sm.]
- 325-G1[sm.]
- 326-A1[sm.]
- 326-B1[sm.]
- 326-C1[sm.]
- 326-D1[sm.]
- 326-E1[sm.]
- 326-F1[sm.]
- 327-B1[sm.]
- * 328-A1[sm.]
- >* 328-B1[sm.]
- * 328-C1[sm.]
- * 328-D1[sm.]
- *329-A1[sm.]
- *329-B1[sm.]
- *329-C1[sm.]
- *329-D1[sm.]
- *329-E1[sm.]
- *329-F1[sm.]
- * 330-A1[sm.]
- * 330-B1[sm.]
- * 330-C1[sm.]

"Onion-ring" map of susceptibilities. Ring elements: **Center** = coordinates, from the data bank. **Radius** = susceptibility. **Thickness** = intra-site suscept. variation.

Uses the same logarithmic convention of the display below to define ring radius. Negative values are plotted in red.

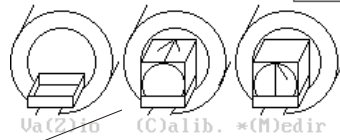

Respectively: empty, calibration and z-axis measure positions.

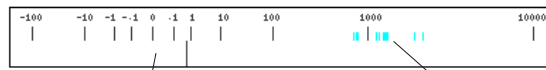

Real-time susceptibility display. (Uses a modified logarithmic scale to allow negative values.)

Note how the measurements "leave their mark" on the dial.

Va(2)io (C)alib. *(M)edir (E)tapa=MRN Sinal=.57 Ruido=±2.001 (F)im

Measuring AMS:

Colecao: DB AMOSTRAS DO ESTADO DE RORAIMA.
Medindo: ANISOTROPIA

Atenuador= 1
Calib.= 123
Fator de calib.= 1.3275
Comprim.(amostra)= 2.2

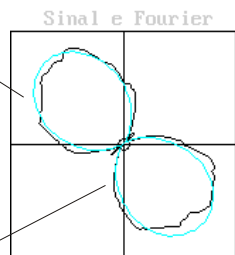

"8-shaped" diagram. The sinusoidal AMS signal is plotted in polar coordinates, so we can simultaneously visualize its amplitude, phase and noise.

Pos.	Amplitude	Fase
1:	24.19 ± 0.69	79.01 ± 0.86
2:	37.53 ± 0.36	99.19 ± 0.79
3:	14.33 ± 0.44	100.30 ± 2.74

This is a real-time display. It is very interesting to see how weak signals "converge to the 8" as data collection proceeds.

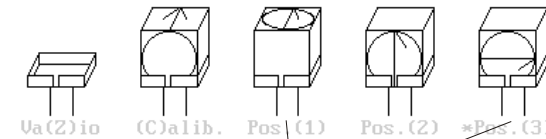

Depicting spin positions directly on-screen eliminates the need of spare instruction sheets.

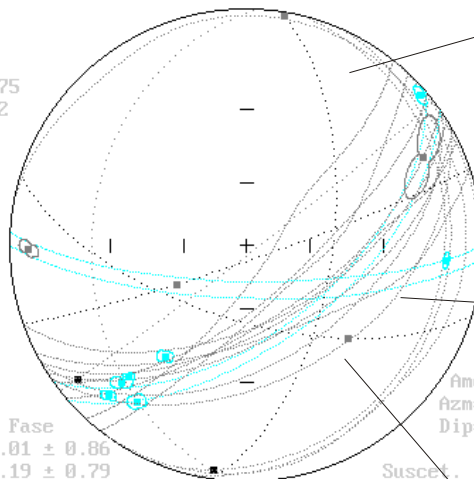

Sitio: 814

- 328-B1[sm.]
- 328-C1[sm.]
- 328-D1[sm.]
- 329-A1[sm.]
- *329-B1[sm.]
- *329-C1[sm.]
- *329-D1[sm.]
- *329-E1[sm.]
- *329-F1[sm.]
- * 330-A1[sm.]
- * 330-B1[sm.]
- * 330-C1[sm.]
- >* 330-D1[sm.]
- * 330-E1[sm.]
- * 330-F1[sm.]

Equal-area totalization diagram. Thanks to faster principal component analysis, no delay is sensible between the end of a 3-pos. measurement and plot update.

"Belt-and-button" representation. Instead of showing MAX, MED and MIN directions, it only represents the MAX-MED plane (belt) and the MAX direction (button).

Suscep.	Decl.	Incl.
MAX: 1501.51	222.77	14.63
MED: 1476.60	119.00	42.19
MIN: 1462.77	327.46	44.15

MAX --- | --- | MED --- | --- | MIN

0.87

Prolate-oblate relationship is color-coded. Prolate samples have their belt grey and their button black (old data) or cyan (new); for oblate samples the reverse occurs.

(4)

Data Bank Structure

As can be seen on the **Old Way** flowchart, all generated information was kept in field books, loose sheets of paper, paper diagrams etc. When this information was needed again, it had to be retyped, causing delays and increasing the probability of mistakes. Worse: user's focus was driven away from the results themselves to the bureaucracy used in obtaining them.

Far from being exclusive to the MINISEP, this problem was present in all levels of our Paleomagnetism laboratory work. Theoretically, the solution was simple: to unify everything on a single environment (see the **New Way** flowchart). Against this simplicity, however, there was a variety of media, philosophies, platforms, languages and measuring units.

After an intermediate step, when each particular data format was converted to the unified format by conversion programs, we finally arrived at the present (unified) situation. For the MINISEP, the present stage comprehends 3 QuickBASIC programs:

- ENTRAR.EXE: dedicated editor, used (mainly) for entering field data;
- MINISEP.EXE: pre-selection and measurement in either BULK or AMS configuration;
- MED-ANI.EXE: AMS averages calculation (per site).

ENTRAR.EXE:

Insertion point for sample A0.

The program computes all magnetic and solar compass parameters.

```

Laboratorio de Paleomagnetismo - Entrada de Dados
-----
"SIT" 814 9,9,95 4,35,42.5 -60,9,51.9 -13.6,25.9
"CIL" "328A" 343 9,18 262 250.1,248.4 58
) "AMO" "A1" 2.2 10.8 "MINISEP" "MOLSPIN",249,58 "MINISEP",249,58
"ANI" "60MT" 231.8,9.5,2262.287 66.8,80.2,2176.778 322.2,2.5,2109.255
"SUS" "MRN" 2239.08
"LAU" "MRN" 280.1,8.1 37.38
"LAU" "2.5MT" 298.2,7.3 21.482
"LAU" "5MT" 303.1,21.3 3.866
"LAU" "7.5MT" 154.37.1 0.831
"LAU" "10MT" 200.3,5.6 1.738
"LAU" "15MT" 189.3,40.2 1.466
"LAU" "20MT" 181.6,-7.4 2.336
"LAU" "25MT" 157.2,12.3 2.308
"LAU" "30MT" 145.3,21.4 1.798
"LAU" "40MT" 151.8,-9.4 2.801
-----
! coLec! Sitio! Bloco, Cilini! Amost! sUsc, Magn, aNiso! Obser! Delet! Fim !
-----
(Suscetib) ( Magnetizacao ) ( Anisotropia )
(Amostra) (Tamanho) (Medidor) (Medidor, Azim, Dip) (Medidor, Azim, Dip) (Ok?)
A0 2.2

```

Data hierarchy is given by line order (e.g. sample A1 belongs to cylinder 328A).

Samples are entered as they are being prepared.

Even old (paper) measurements can be entered.

The unified structure allows, among other things, the pre-selection of only the samples you will really measure. During measurement, the program moves automatically to the next selected sample, as soon as the preceding one is finished (eliminating thus the endless retyping of sample names).

MINISEP.EXE (Pre-selection):

Horizontal arrow keys change site.

```

Colecao: DB AMOSTRAS DO ESTADO DE RORAIMA.
Siteio 811 Siteio 812 > Siteio 814 Siteio 817 Siteio 819
328-A1[sma]
328-B1[sma]
328-C1[sma]
328-D1[sma]
329-A1[sma]
*329-B1[s..]
*329-C1[s..]
*329-D1[s..]
*329-E1[s..]
*329-F1[s..]
* 330-A1[sm.]
* 330-B1[sm.]
* 330-C1[sm.]
* 330-D1[s..]
* 330-E1[s..]
)* 330-F1[s..]

A small change in tabulation is an aid to visualize sample grouping.

[sma] significa: suscetibilidade, magnetizacao, anisotropia (ja' medidas).
Para selecionar, mude as marcas (*) usando <ENTER> e as teclas de flechas.
Medir: (S)uscetibilidade Medir: (A)nisotropia (F)im

```

Vertical arrow keys & <ENTER> pre-select.

"S" Starts measuring BULK.

"A" Starts measuring AMS.

An unexpected consequence of having all information together: AF degaussing (indicated by the "m" in "[sma]") was observed to affect the AMSs measured from a particular group of samples: the strong-but-low-anisotropic ones.

Tests done with isothermal remanent magnetization (IRM) show that inducing magnetization on this kind of samples affects still more their anisotropy, and in a predictable way. More studies are being done to find out whether this is a real effect or is a measurement artifact, associated to the physical principle used by the MINISEP system (coil inductance).

(5)

Site-Level Average

The main objective here is to work, as much as possible, graphically throughout the process. It is interesting to note that calculating the best representative for a series of measurements or the average for a group of samples is mathematically equivalent.

As in the AMS measuring program, the diagram of choice was an equal-area projection of the lower (positive) hemisphere, in which the scattering "size" rather than the scattering "shape" is more accurately displayed. Also, belt-and-button representation is used instead of 3-different-shapes-for-3-different-axes representation. This has several reasons:

- The diagram gets less cluttered; symbols can be smaller; error indicators can be displayed;
- The prolate-oblate relationship is easily recognizable (dark belts = oblate; dark buttons = prolate);
- The final average (represented only by its errors) don't need special symbolism.

In the example given here, the 330ies are the tight-grouped set of prolate samples on the lower left. The 328ies and 329ies are more scattered (some had to be unselected) and more oblate-like. Nonetheless, they all average well together to give the dike plane for this site (cyan belt; pole=337.4,27.3).

The X-shaped structure (actually 2 crossing bars) is an attempt to show the directionality of errors caused by field correction (the shorter leg) and sample marking (the longer). An interesting conclusion from the X-bars: to drill from outcrop "walls" instead of directly from the ground makes these directional errors more evenly distributed.

MED-ANI.EXE:

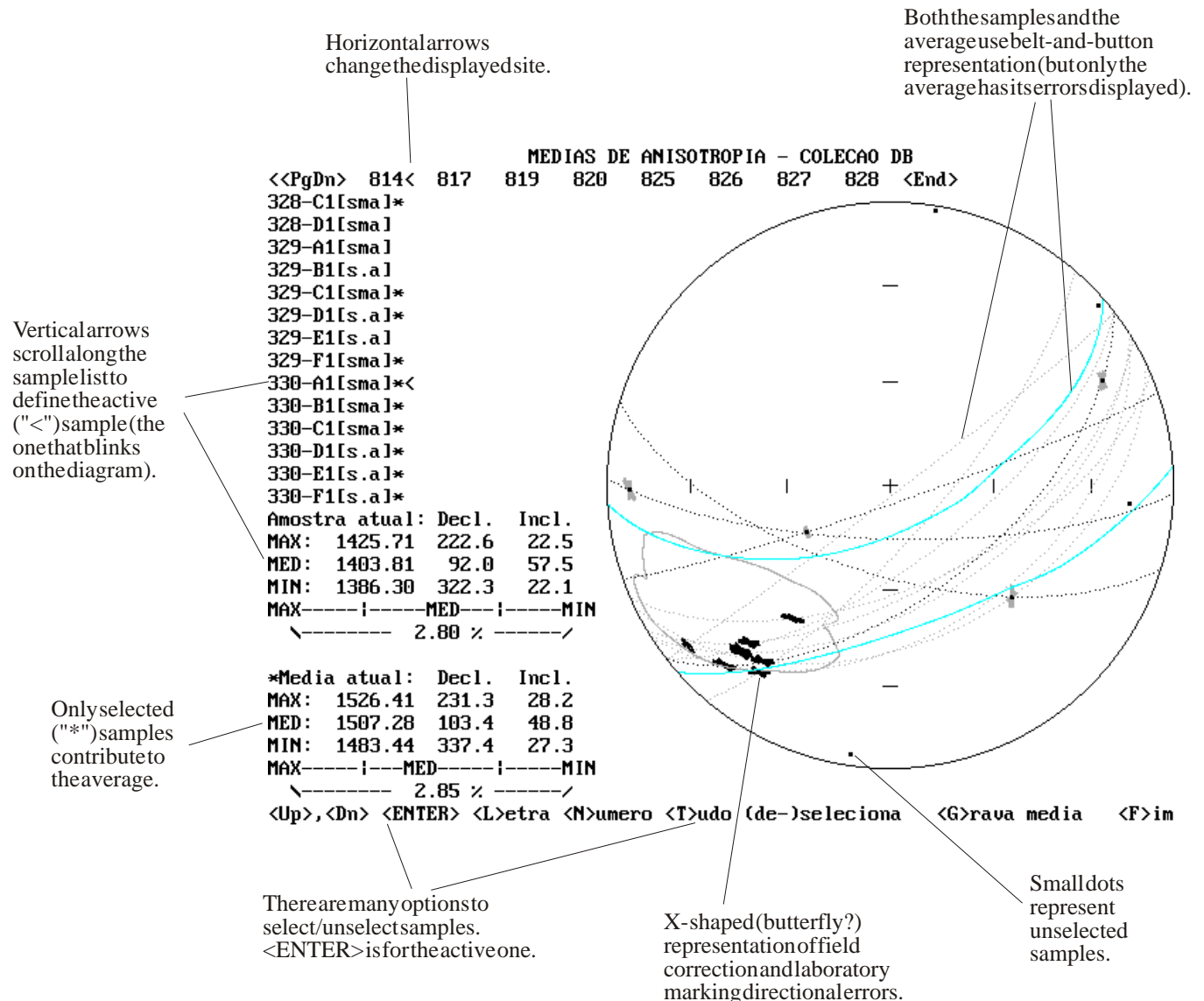

Measuring AMS: The Old Way

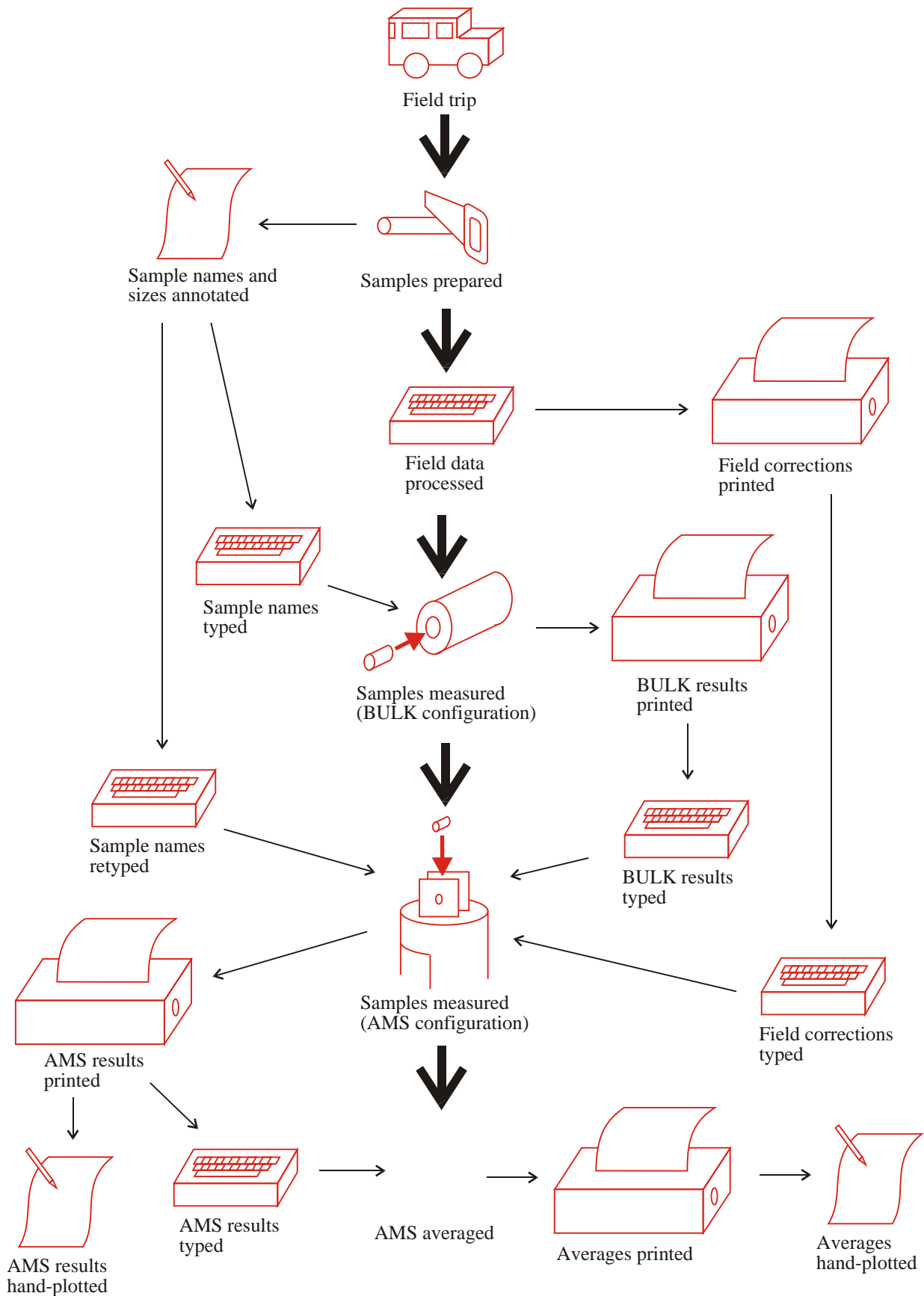

Measuring AMS: The New Way

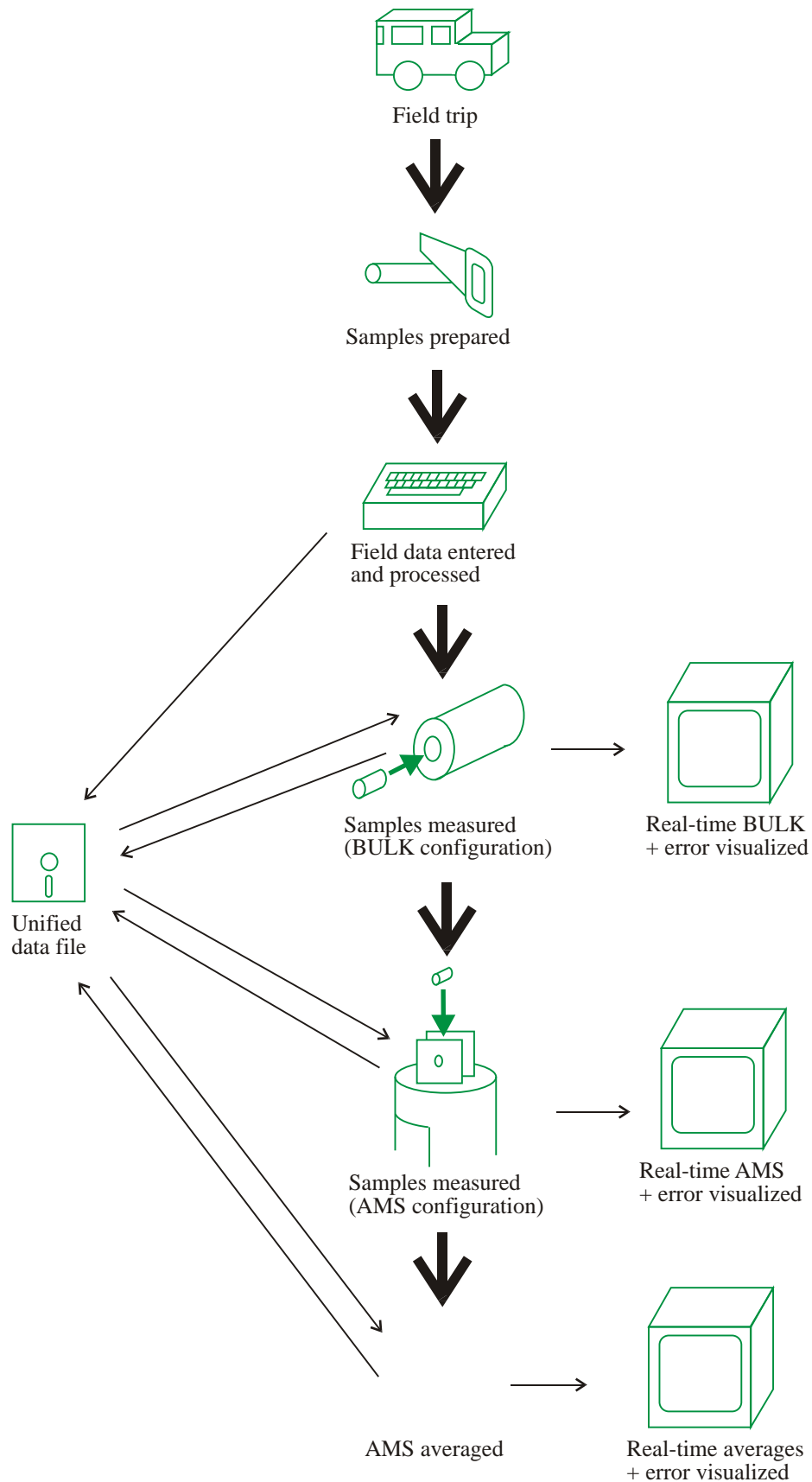

BULK Measurement Screenshot

Colecao: DB AMOSTRAS DO ESTADO DE RORAIMA.
 Medindo: SUSCETIBILIDADE

Sitio: 814

Atenuador= 100
 Calib.= 88
 Fator de calib.= .0559
 Comprim.(amostra)= 2.2

- 325-C1[sma]
- 325-F1[sma]
- 325-G1[sma]
- 326-A1[sma]
- 326-B1[sma]
- 326-C1[s.a]
- 326-D1[sma]
- 326-E1[sma]
- 326-F1[s.a]
- 327-B1[sma]
- * 328-A1[sm.]
- >* 328-B1[sm.]
- * 328-C1[sm.]
- * 328-D1[sm.]
- *329-A1[sm.]
- *329-B1[s..]
- *329-C1[sm.]
- *329-D1[s..]
- *329-E1[s..]
- *329-F1[sm.]
- * 330-A1[sm.]
- * 330-B1[sm.]
- * 330-C1[sm.]

Already on file:
 [s]usceptibility,
 [m]agnetization &
 [a]nisotropy (4)

Mapa de Suscetibilidades Inicias

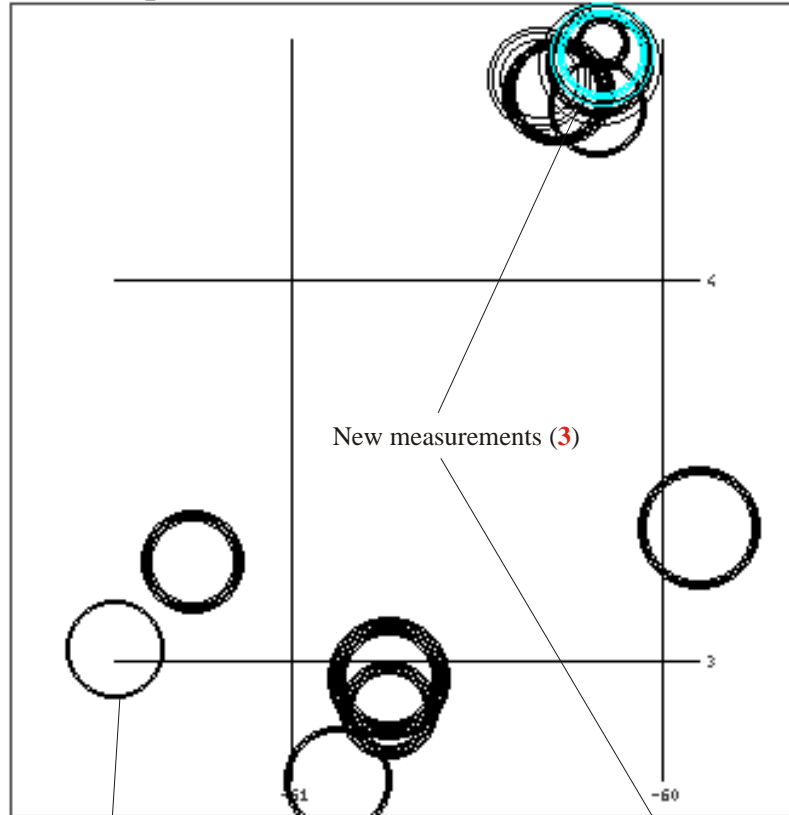

New measurements (3)

Curva de Suscetibilidade

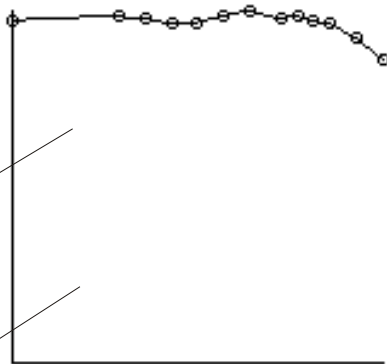

Susceptibility vs.
 temperature (3)

Amostra de cilindro
 Etapa ant.=700C
 Susc. ant.=1922.58

Previous
 information (4)



Ua(2)io

(C)alib. *(M)edir

Optional zeroing (1)

Old measurements (4)



"Logarithmic"
 dial (1)

(E)tapa=MRN

Sinal=.57

Ruido=±2.601

(F)im

Immediate signals (1)

Noise indication (2)

AMS Measurement Screenshot

Colecao: DB AMOSTRAS DO ESTADO DE RORAIMA.
Medindo: ANISOTROPIA

Atenuador= 1
Calib.= 123
Fator de calib.= 1.3275
Comprim.(amostra)= 2.2

Old measurements (3)

Sitio: 814
328-B1[sma]
328-C1[sma]
328-D1[sma]
329-A1[sma]
*329-B1[s.a]
*329-C1[sma]
*329-D1[s.a]
*329-E1[s.a]
*329-F1[sma]
* 330-A1[sma]
* 330-B1[sma]
* 330-C1[sma]
>* 330-D1[s.a]
* 330-E1[s..]
* 330-F1[s..]

New measure-
ments (3)

Active (">")
measurement:
blinks on the
equal-area
diagram (3)

Amostra de cilindro
Azm=316 Lav.=MRN
Dip= 38 Sus2= 1463.9

Previous
information (4)

Suscet.	Decl.	Incl.
MAX: 1501.51	222.77	14.63
MED: 1476.60	119.08	42.19
MIN: 1462.77	327.46	44.15
MAX----- ----- MED----- ----- MIN		
↖----- 0.87 % -----↗		

Measurement
results (4)

Spin
signals (1)

Sinal e Fourier

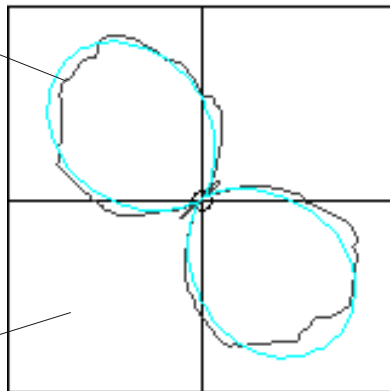

Immediate
plotting (3)

Error
visualization (2)

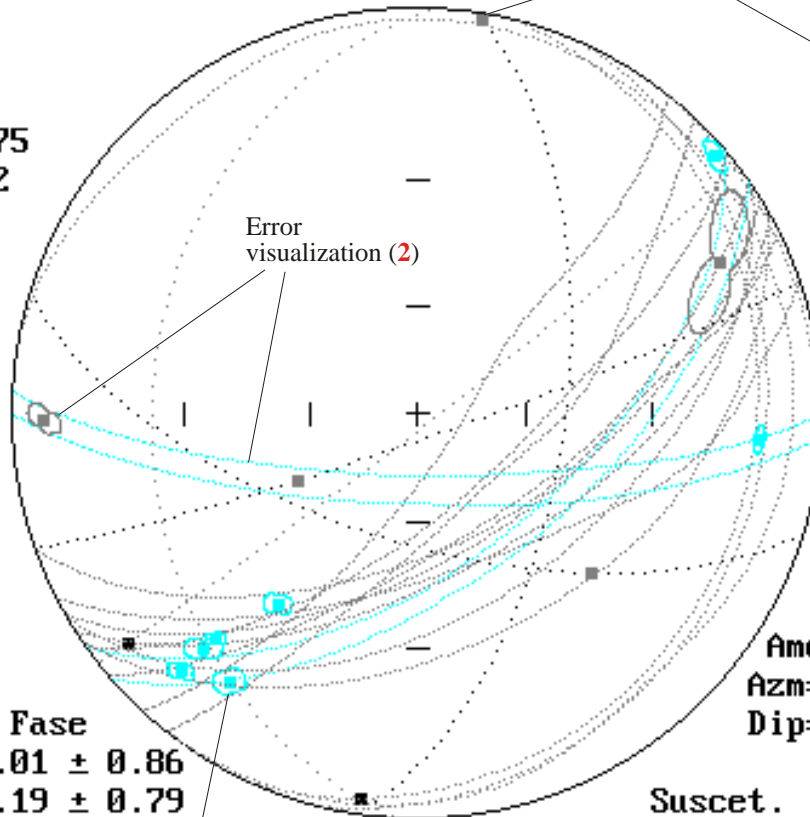

Partial results
& respective
errors (2)

Pos.	Amplitude	Fase
1:	24.19 ± 0.69	79.01 ± 0.86
2:	37.53 ± 0.36	99.19 ± 0.79
3:	14.33 ± 0.44	100.30 ± 2.74

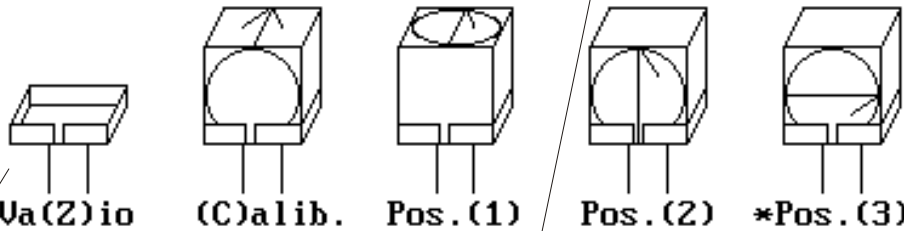

Empty holder subtraction (1)

New measurements (3)

Move between sites (4)

(P)rox. (V)olta (F)im

Future Developments

The philosophy expands to other apparatuses and languages.

Depicted below is a screenshot from the new VSM (Vibrating Sample Magnetometer) controlling program, written in Visual Basic for Windows.

Yes, it is in English! But it is not working properly (yet) and has some key characteristics (like error calculation) absent. Our aim is to propagate errors from each pair of measurements: $H \times M$ up to the final H_c , H_{cr} etc parameters.

In any case, running it already makes the VSM to play a nice music -- while it selects the best frequency to operate (the software is executable in machines of different speeds without alteration).

To use the VSM:

First, you select your sample from a list (among them, 2 special ones: emptyholder and calibsample, are always present).

Second, you set the maximum field H to be applied.

Finally, you choose your loop preferences and press START. (Remanence = M with H off; Hysteresis = M with H on).

Real-time indication of H & M values.

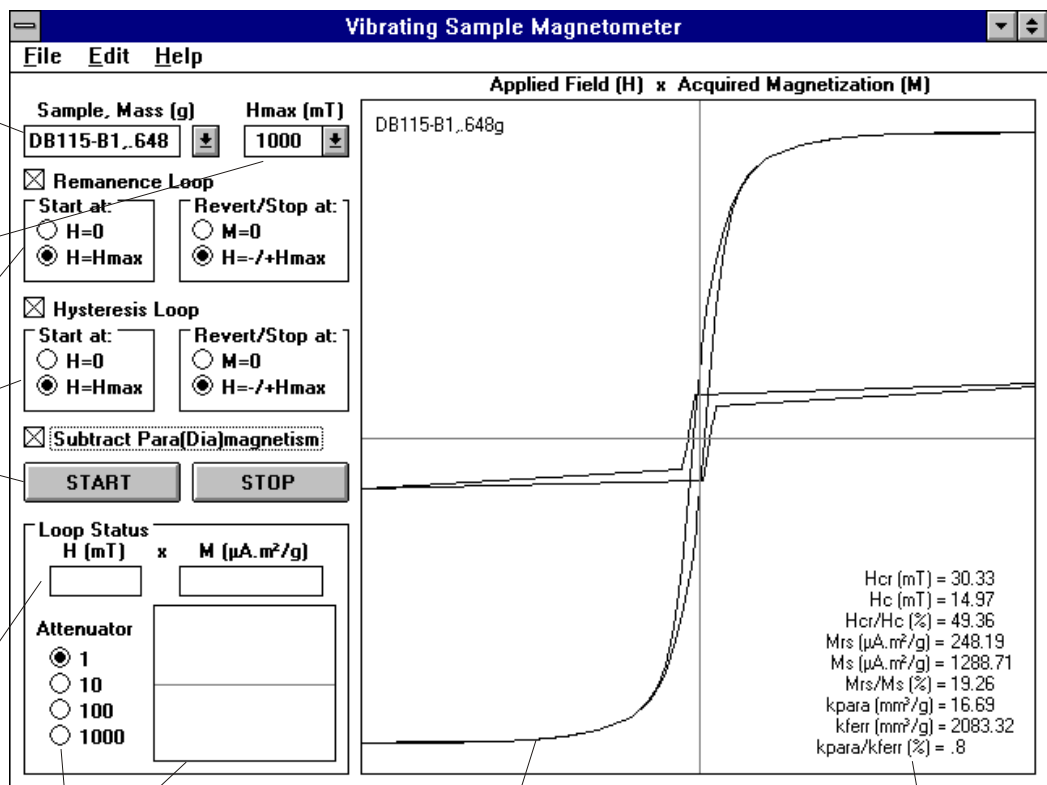

The system "asks" for attenuation when needed, and the vibration noise can be monitored through an "oscilloscope".

The diagram is drawn as the loop proceeds. Note that things like scale, units and error bars are missing. But don't forget: this is an unfinished job!

Automatically calculated parameters. H_{cr} comes from Remanence; all the rest from Hysteresis. The last 3 depend on subtracting Para(Dia)magnetism.

