

Use a locally made up fork or tool **FACOM D115** as a lever to remove the window winder, taking care to protect the door trim with a piece of cloth (1) and to place a block between the cloth and the tool.

Front and Rear Door Interior Opening Control

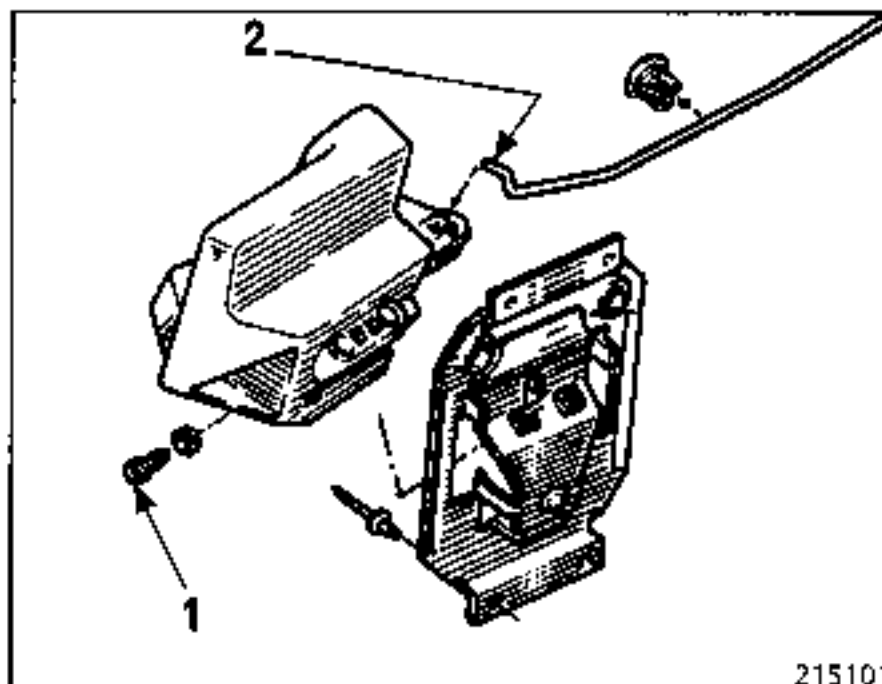

Remove screws (1) and separate the interior opening control from the linkage (2).

REMOVING THE WINDOW WINDER (1)

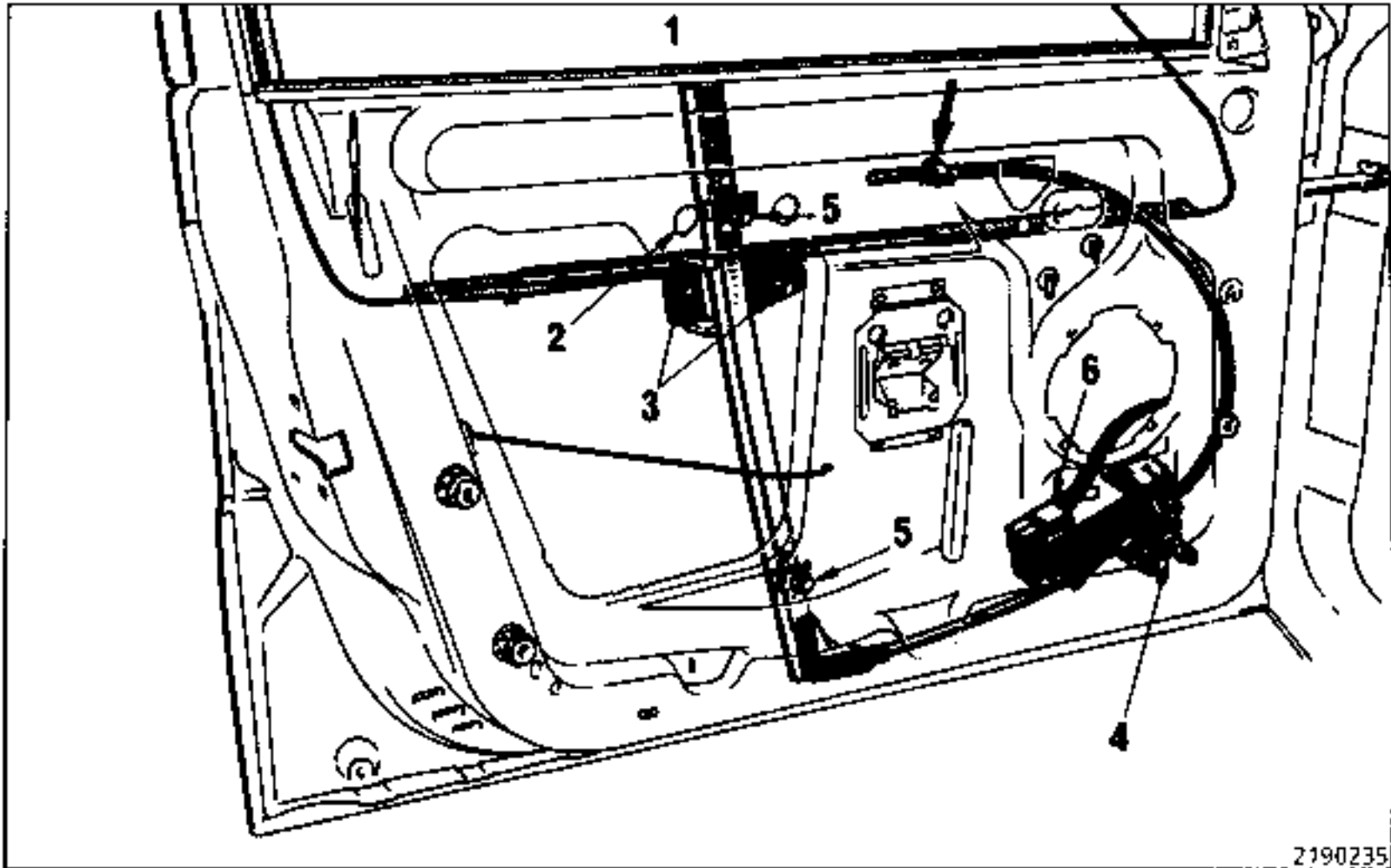

Electric mechanism :

After removing the trim, remove the internal rubbing strip by pulling it upwards.

Raise the window so that the mountings can be seen opposite holes (2). Remove the mountings (3) from the base of the window.

Optional measure : raise the window again by hand and hold it in place using a piece of adhesive tape.

Disconnect the feed from motor (6).

Remove the mountings from the mechanism (4) and the rail (5).

Tilt the assembly and take it out through the door aperture.

Adjusting :

fit the complete mechanism in place in the door (run up the screws without tightening them and connect the power supply).

Re-secure the window completely after pre-tightening the mountings in the bottom of the window (if necessary guide the window to position it correctly in the frame).

Lower the window again and tighten all the mountings.

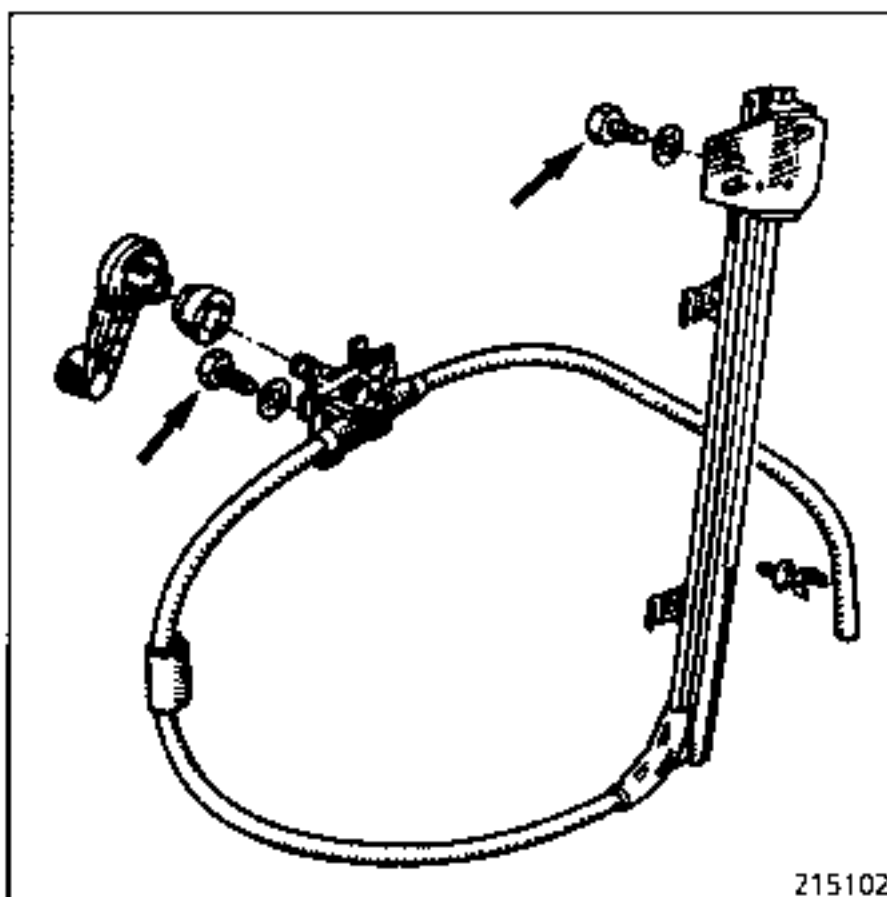

Mechanism with window winder :

Remove the mountings :

- from the rail,
- from the rack.

Tilt the assembly and take it out through the opening in the door.

Adjusting :

Fit in place the complete mechanism in the door (run up the screws by hand without tightening them and connect the power supply).

Secure the window back on the mechanism, raise the window completely after pre-tightening the mountings in the bottom of the window (if necessary guide the window into its position in the frame).

Lower the window again and tighten all the mountings.

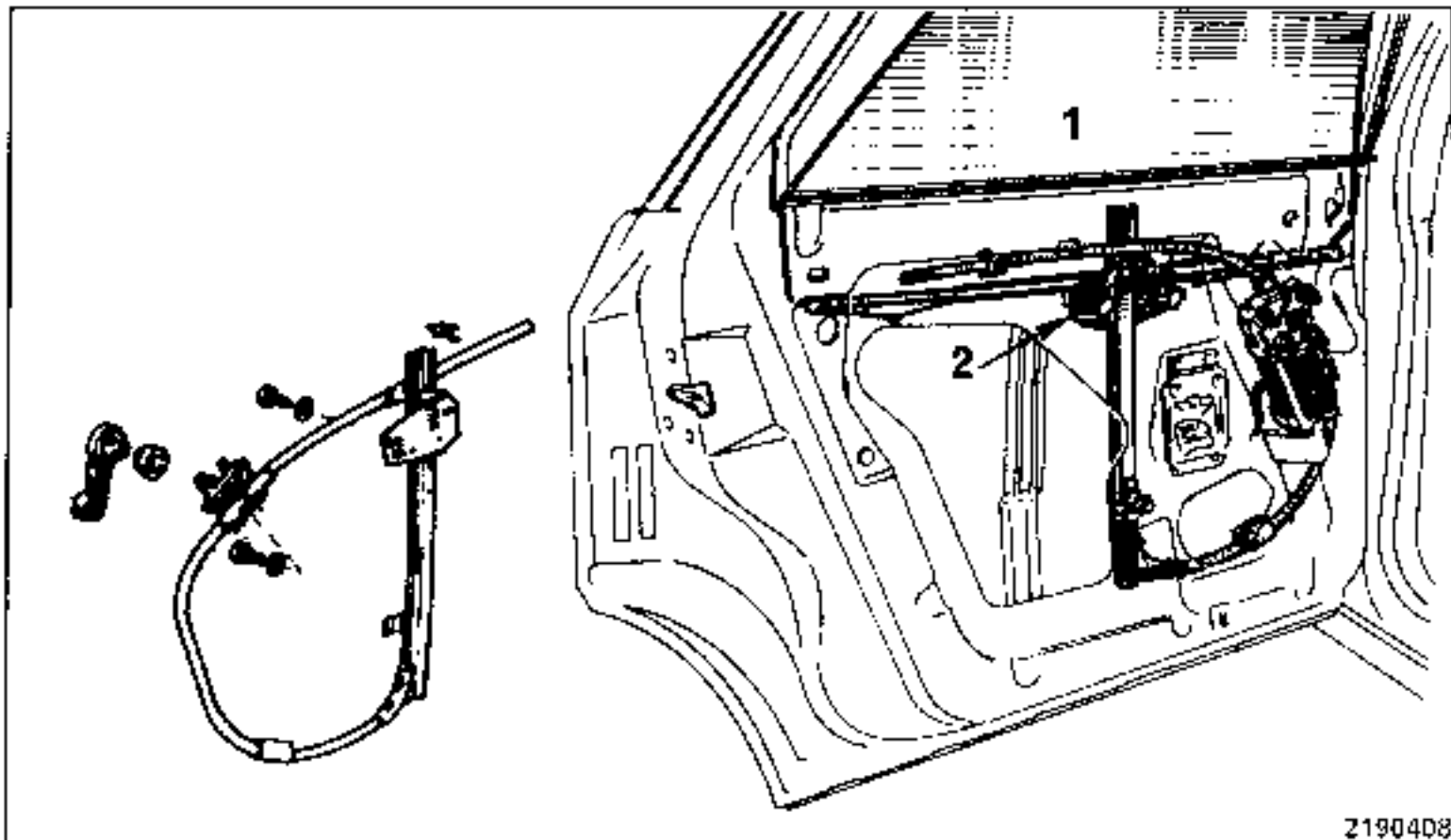
REMOVING THE WINDOW WINDER MECHANISM (1)**Electric mechanism**

After removing the door trim, remove the inner rubbing strip by pulling it upwards.

Optional measure : raise the window so that the mounting are visible opposite holes (2). Remove the mountings from the bottom of the window.

Disconnect the power supply from the motor.

Remove the mountings from the rail and the motor.

Tilt the assembly and take it out through the opening in the door.

Mechanism with handle

Remove the mountings :

- from the rail,
- from the rack.

Tilt the assembly and take it out through the opening in the door.

Adjusting

Fit in place the complete mechanism in the door (run up the screws by hand without tightening them). Connect the power supply.

Secure the window back on the mechanism, raise the window completely after pre-tightening the mountings in the bottom of the window (if necessary guide the window into its position in the frame).

Lower the window again and tighten all the mountings.

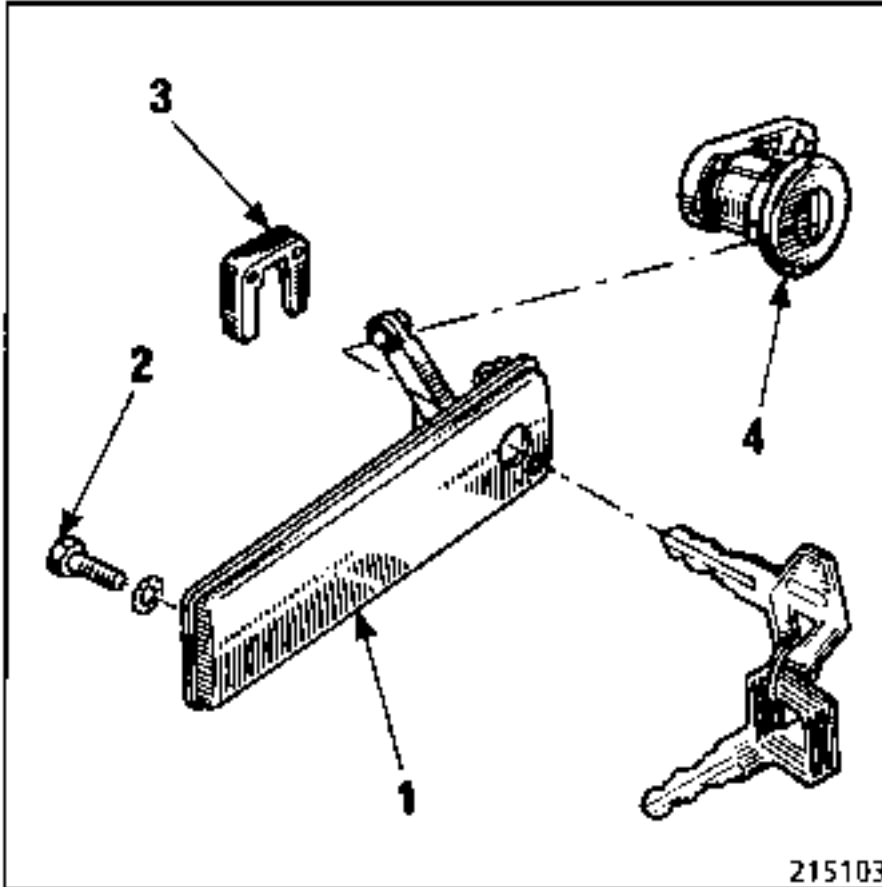

215103

- 1 Finger plate
- 2 Finger plate mounting
- 3 Lock barrel mounting
- 4 Lock barrel

REMOVING THE EXTERNAL FINGER PLATE

Remove the finger plate by moving it in the direction shown in the drawing below.

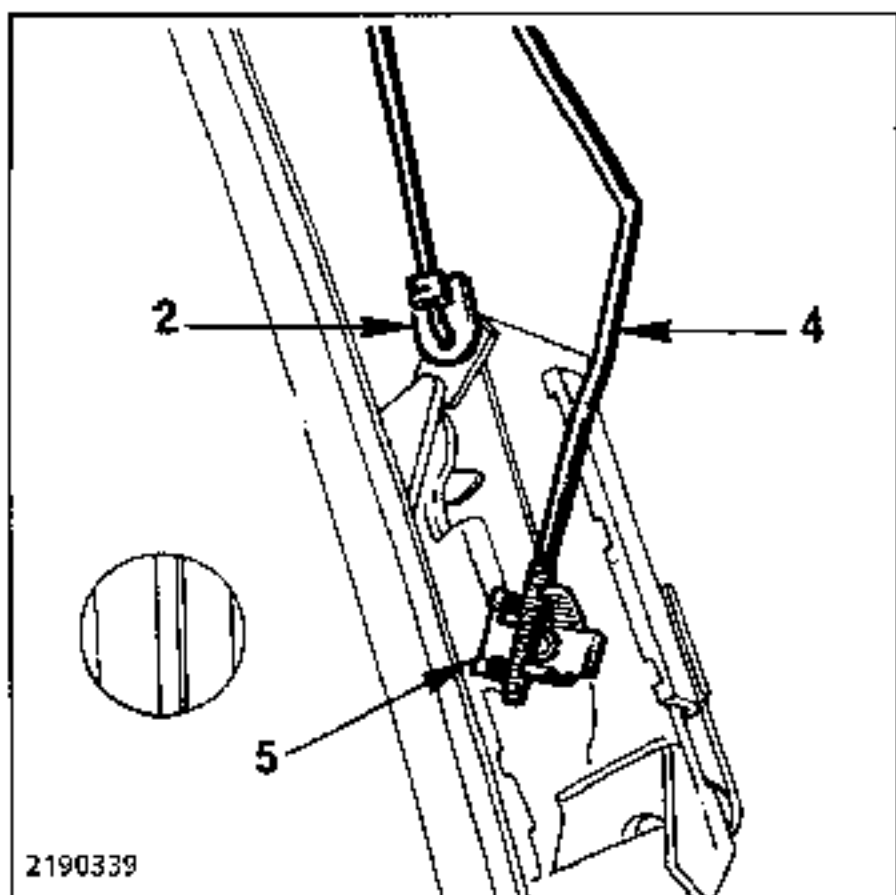
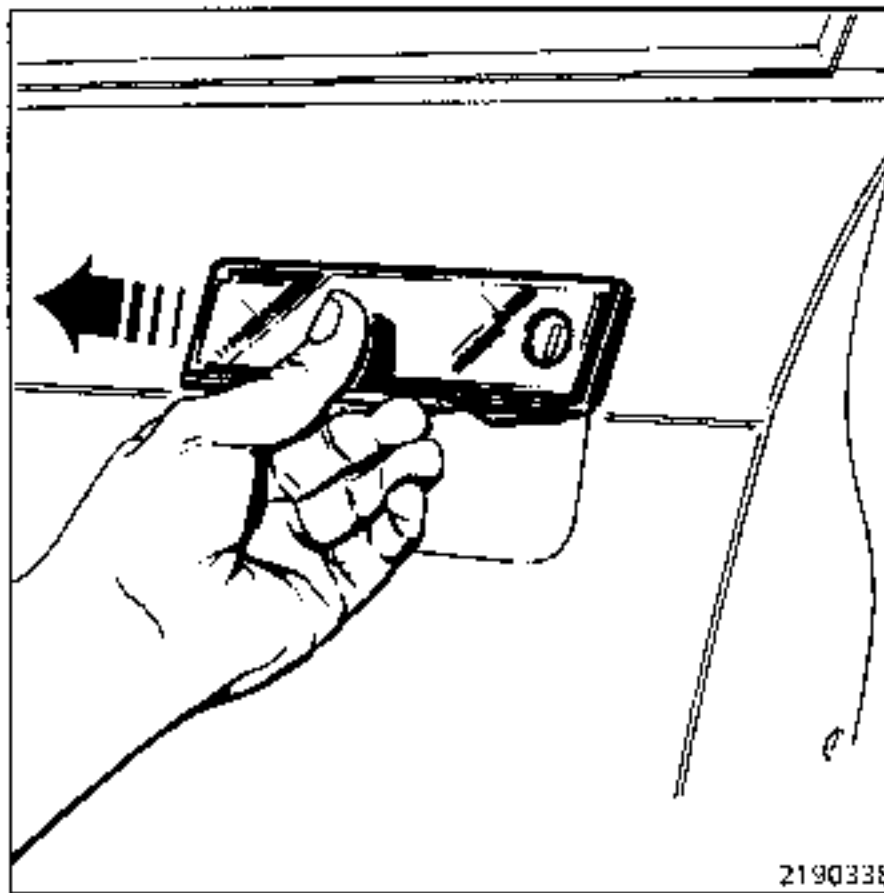
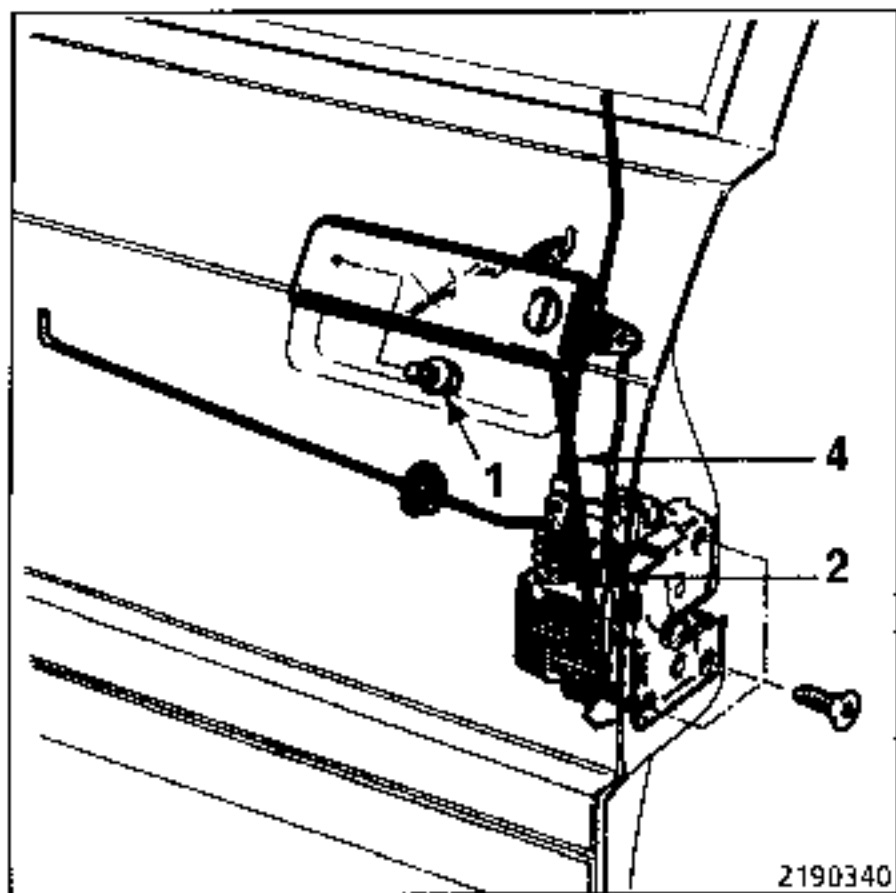

Press the finger plate forwards to free it from the panel.

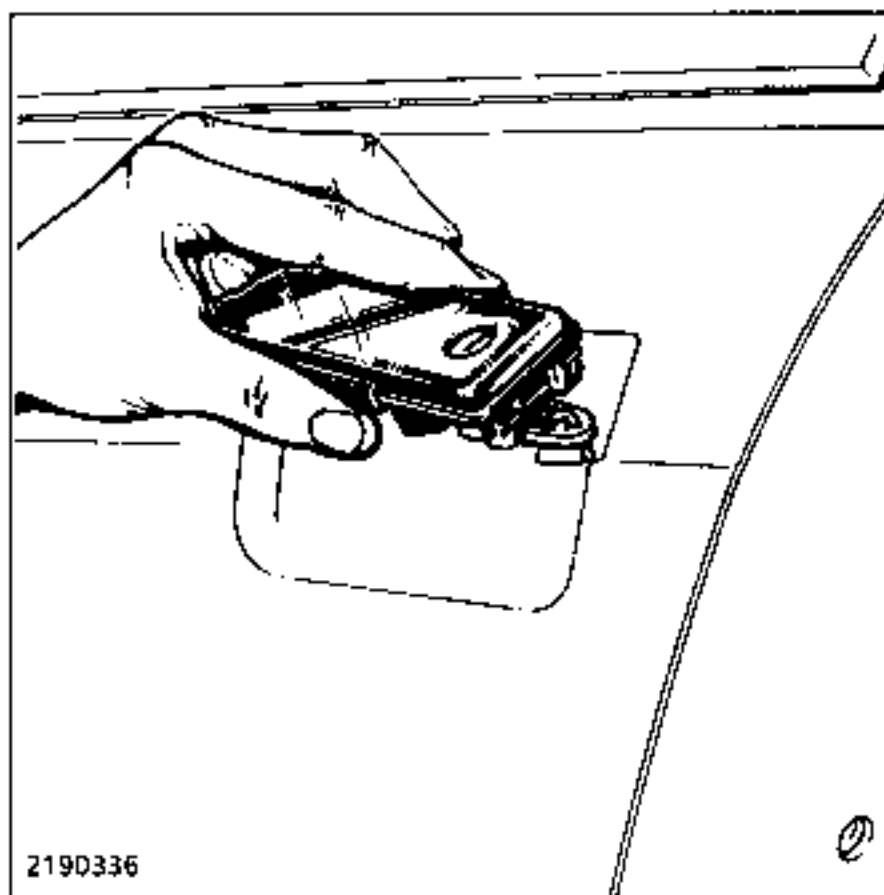

After removing the door trim and the plastic sheet :

- remove mounting screw (1) from the external finger plate,
- uncouple locking rod (2) by unfastening it near the lock.

Using your thumb, push clip (5) and rod (4) downwards and take the upper end of the rod (4) out of the door panel.

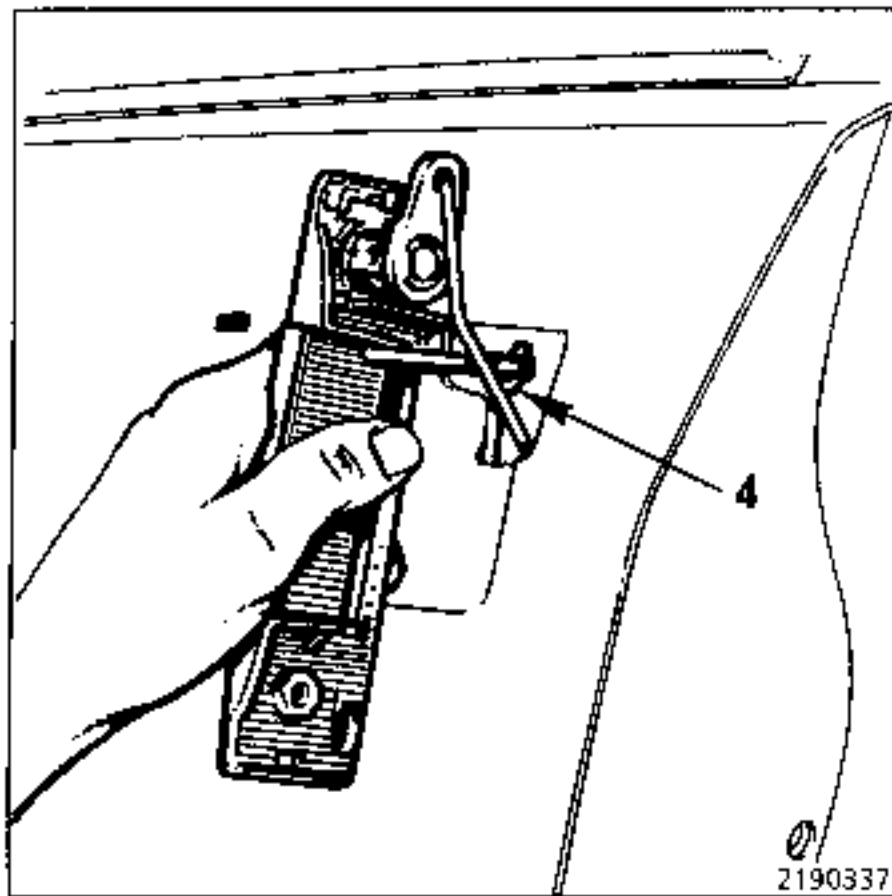

2190337

Free the finger plate from the rod (4) by turning the finger plate vertically.

NOTE : it is essential to take the finger plate out without rod (4) in order to avoid damaging its clip.

To adjust the opening of the finger plate if the rod has become detached from its clip (5), clip rod (4) back on after refitting the finger plate.

Unscrew rod (4) from its clip (5) to remove.

REMOVING THE LOCK

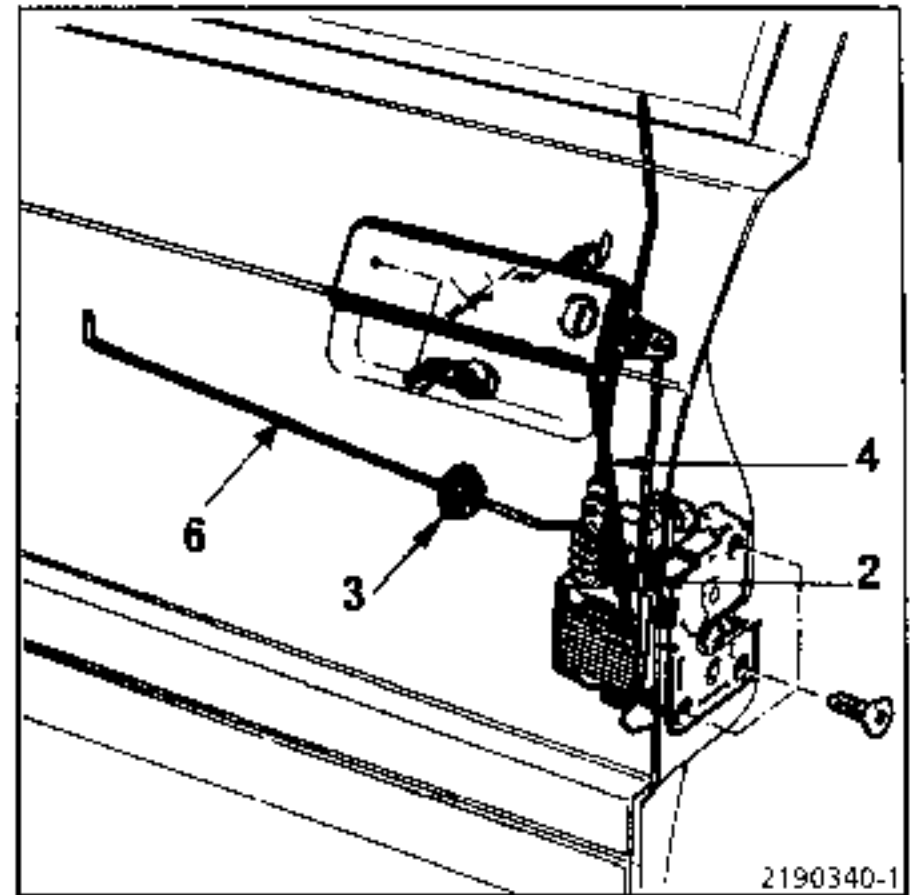

2190340-1

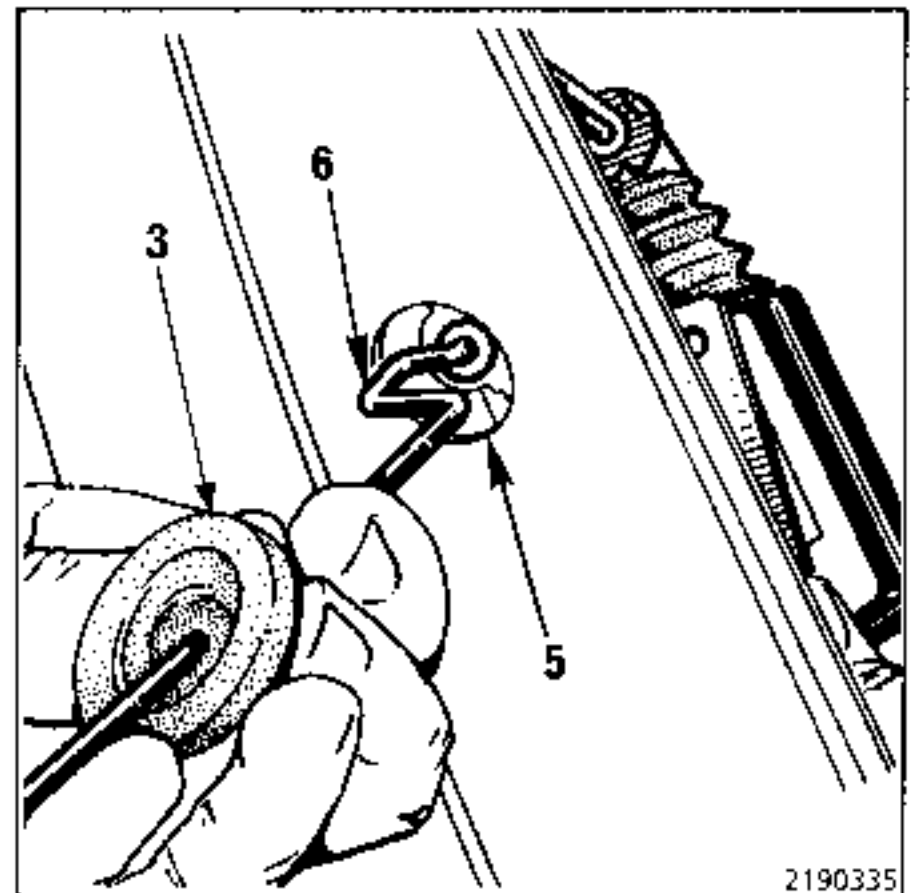

2190335

firstly remove the external finger plate together with the locking rod, then :

- disconnect the power supply;
- remove the mountings;
- free the rubber grommet (3);
- move the lock towards slot (5) to disengage the opening control (6).

Take the lock out through the opening.

REMOVING THE LOCK

WIRING HARNESS

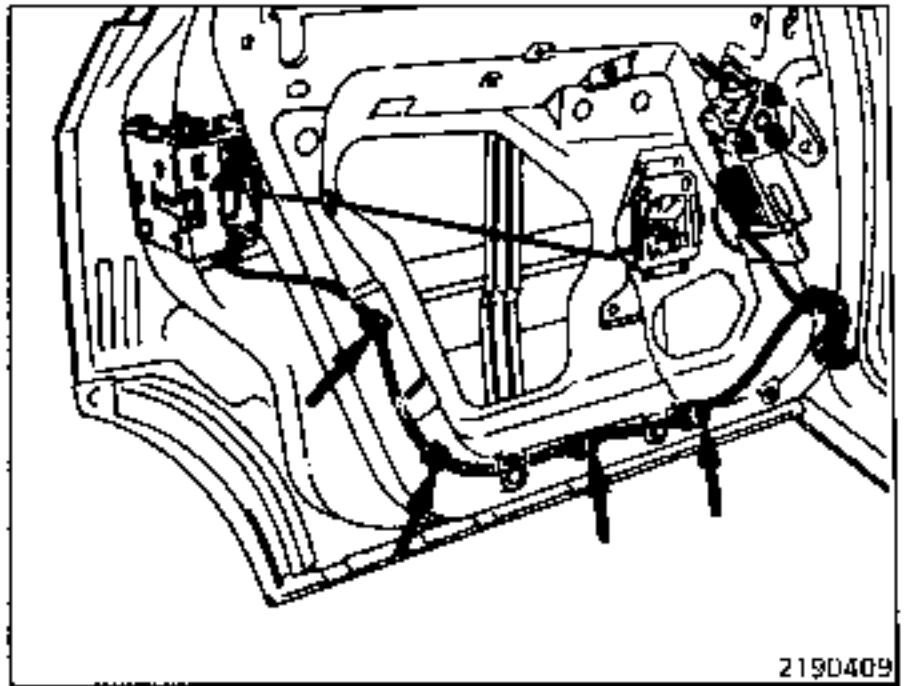
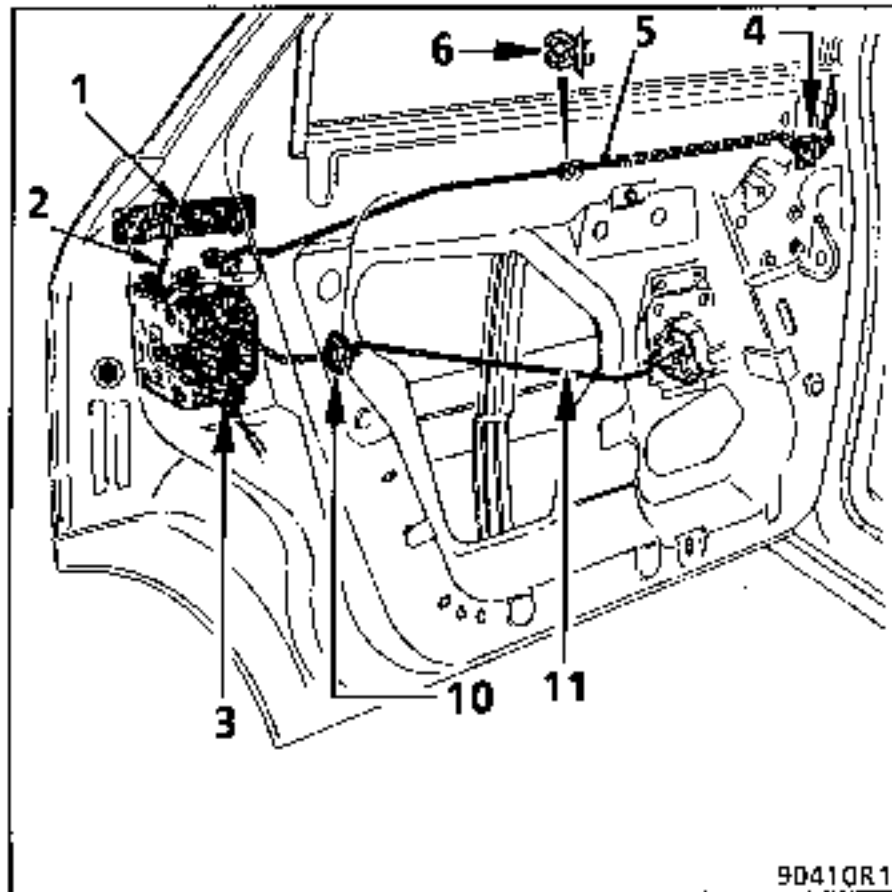

2190409

After removing the external finger plate and window :

- disconnect the power supply (3),
- remove the two mountings from the window winder rail (see note),
- unclip the rod from clip (6),
- remove fork (4) holding rod (5) in position and push it into the door,
- remove the three mounting screws from the lock,
- move the lock towards hole (10) to disengage the internal opening control rod (11).

Take the lock out through the opening.

NOTE : the two mountings have to be removed from the window winder rail since rod (5) passes between the door and the window winder rail.

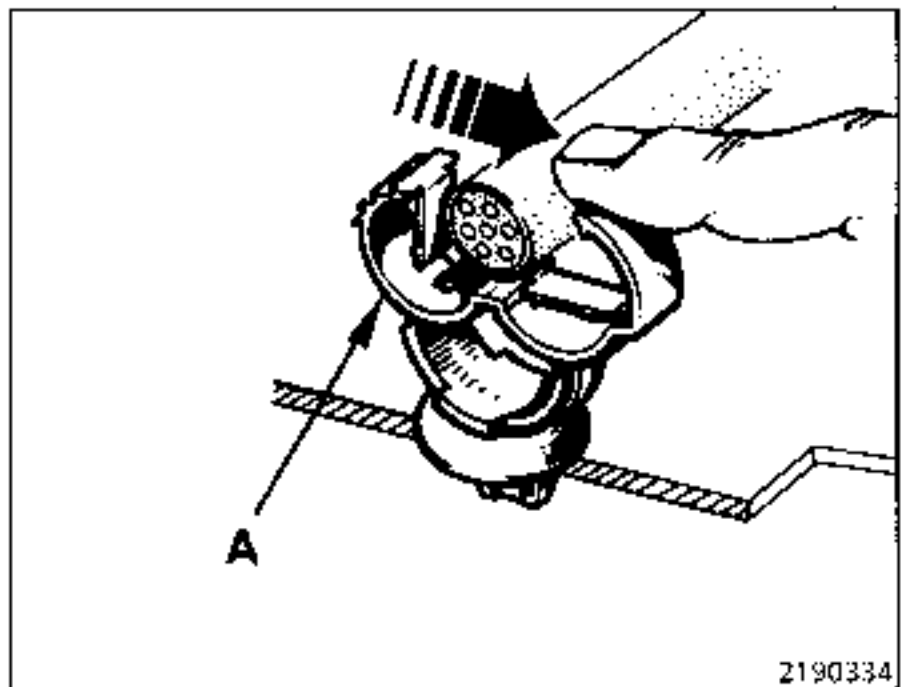

2190334

Harness mounting clip.

REMOVING EXTERNAL FINGER PLATE (1)

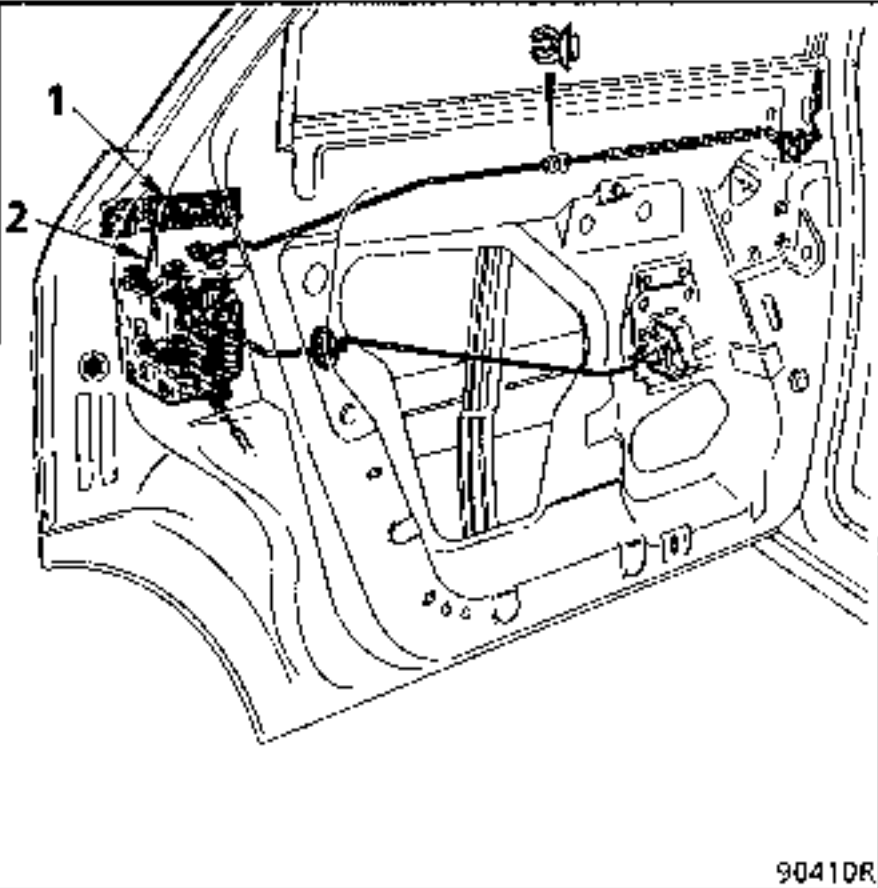

After stripping the door :

NOTE : it is essential to remove the finger plate without rod (2) in order to avoid damaging its clip.

- remove the mounting screw from the external finger plate.

Remove the finger plate in the direction shown in the drawing below.

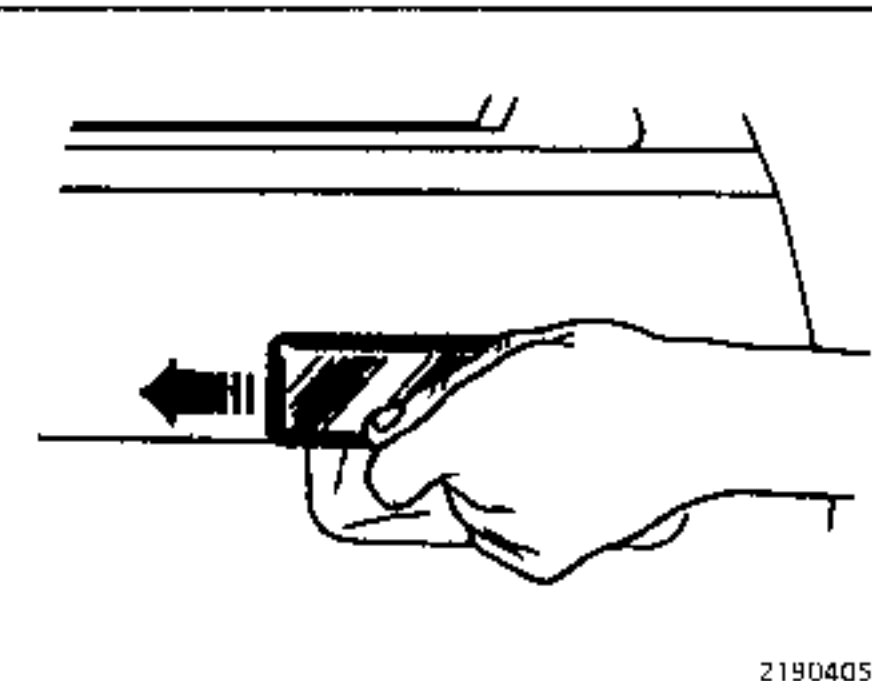

Push the finger plate forwards then disengage it from the panel.

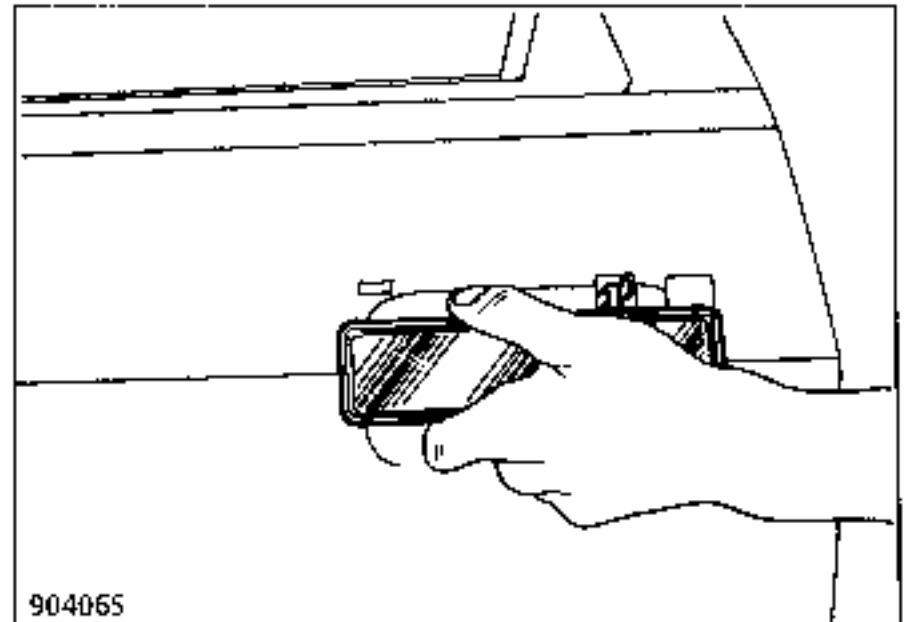

Using your thumb, push the clip on control rod (2) downwards and take the upper end of rod (2) out of the door panel.

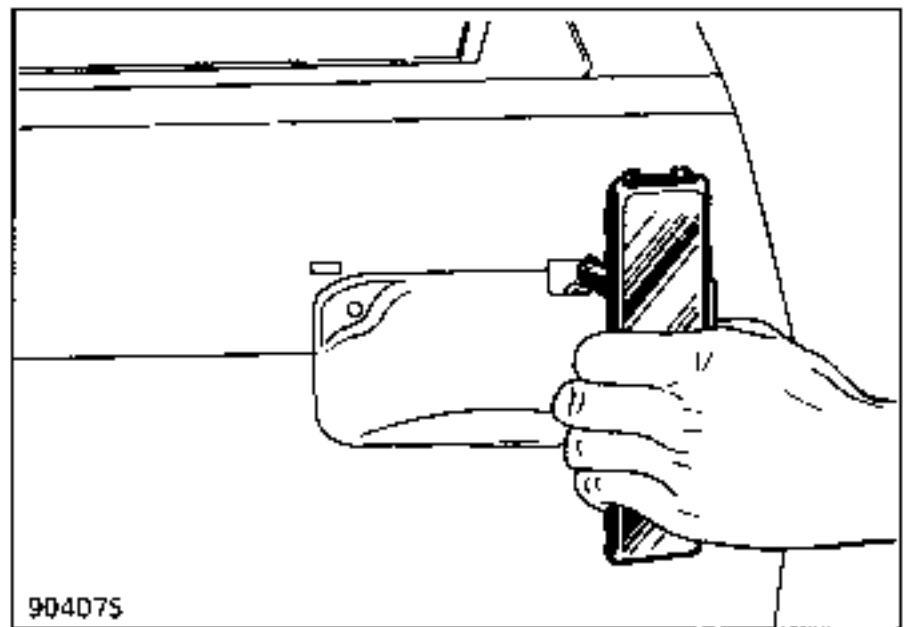

Disengage the finger plate from rod (2) holding the finger plate vertically.

Adjust the opening of the finger plate if the rod has come unfastened from its clip.

Clip rod (2) back in place after refitting the finger plate.

unscrew the clip to remove rod (2).

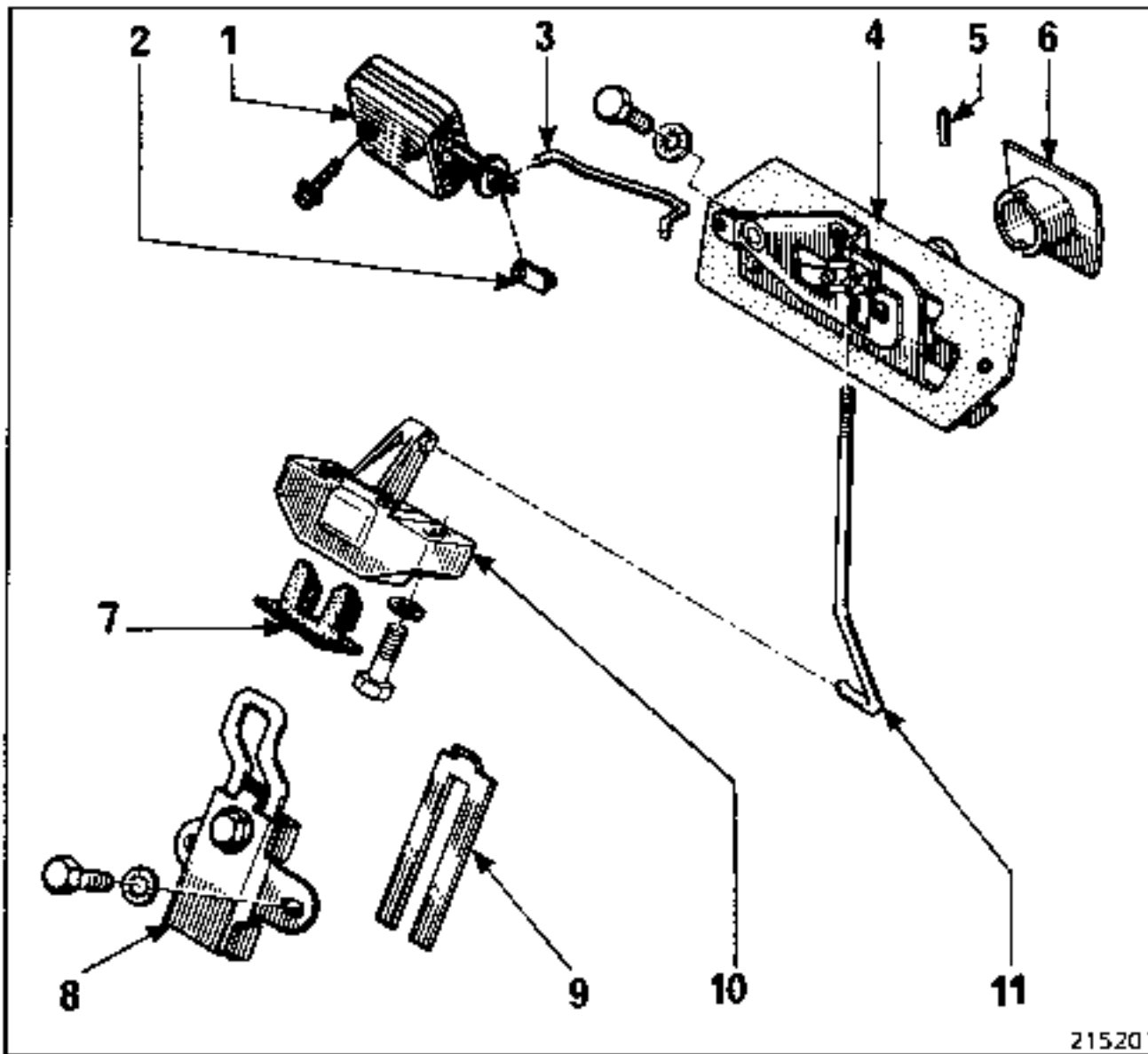

215201

- 1 Locking motor
- 2 Rod mounting clip
- 3 Locking rod
- 4 External opening control
- 5 Rollpin
- 6 Lock cover

- 7 Centring stop
- 8 Striker plate
- 9 Shim
- 10 Lock
- 11 Opening rod

Remove :
- the number plate,
- the number plate mounting moulding.

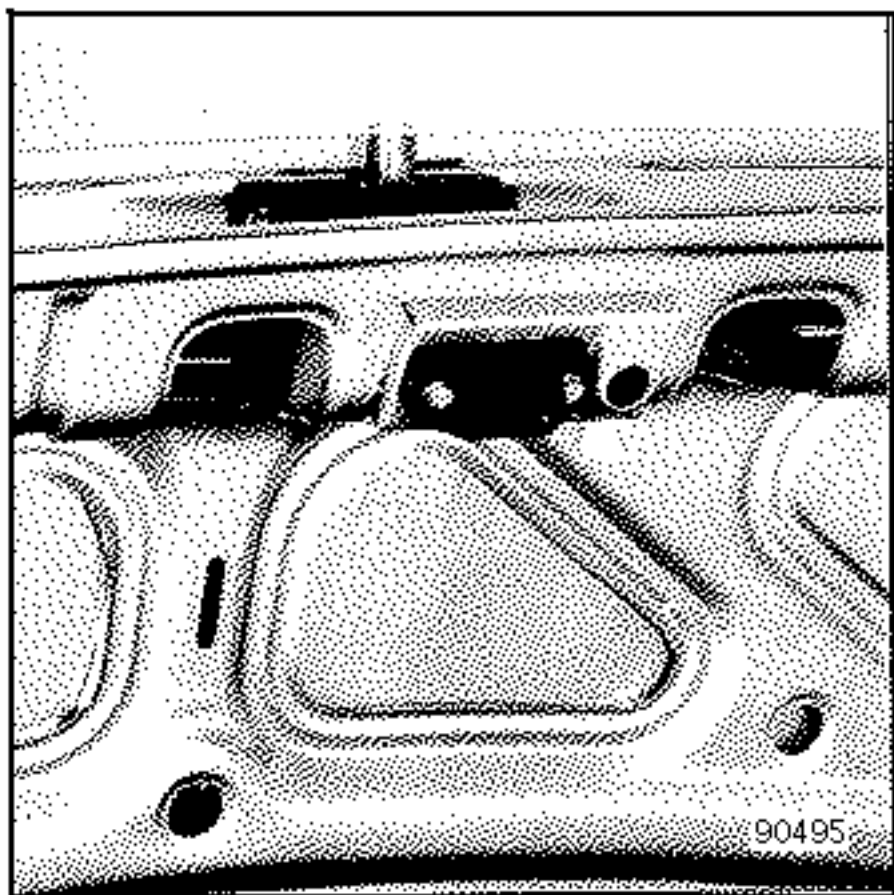

Remove the latch by disengaging it from the control rod.

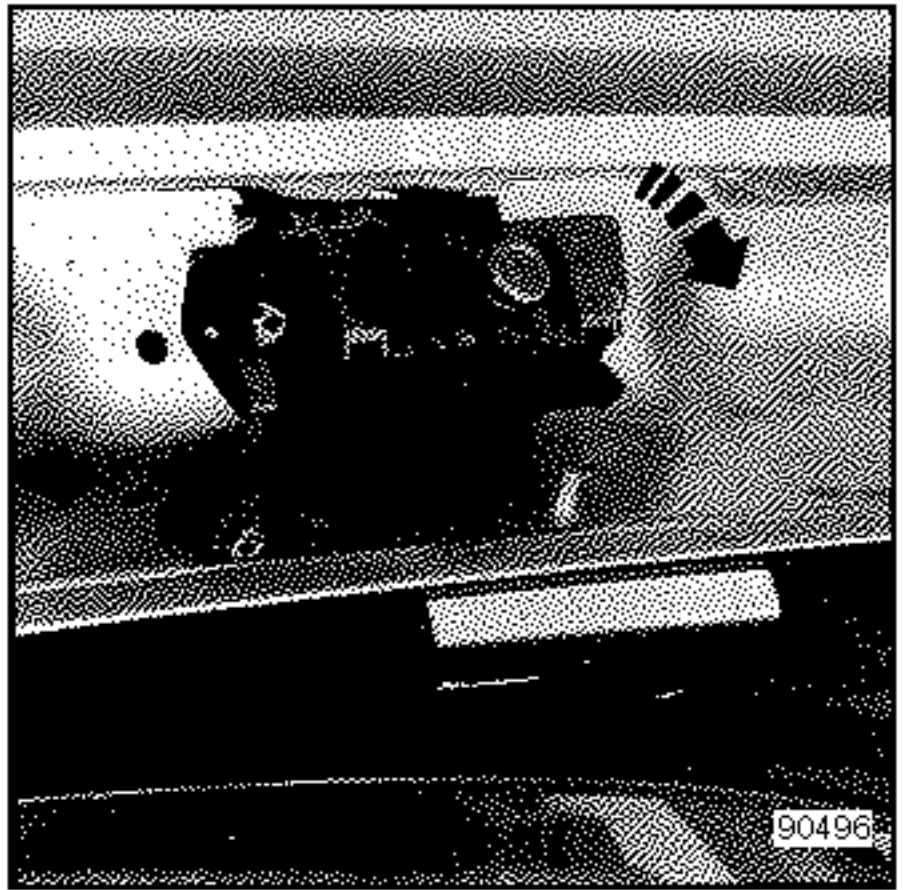

Unclip the electric locking rod. Tilt the lock outwards in order to remove it.

Removing the lock barrel

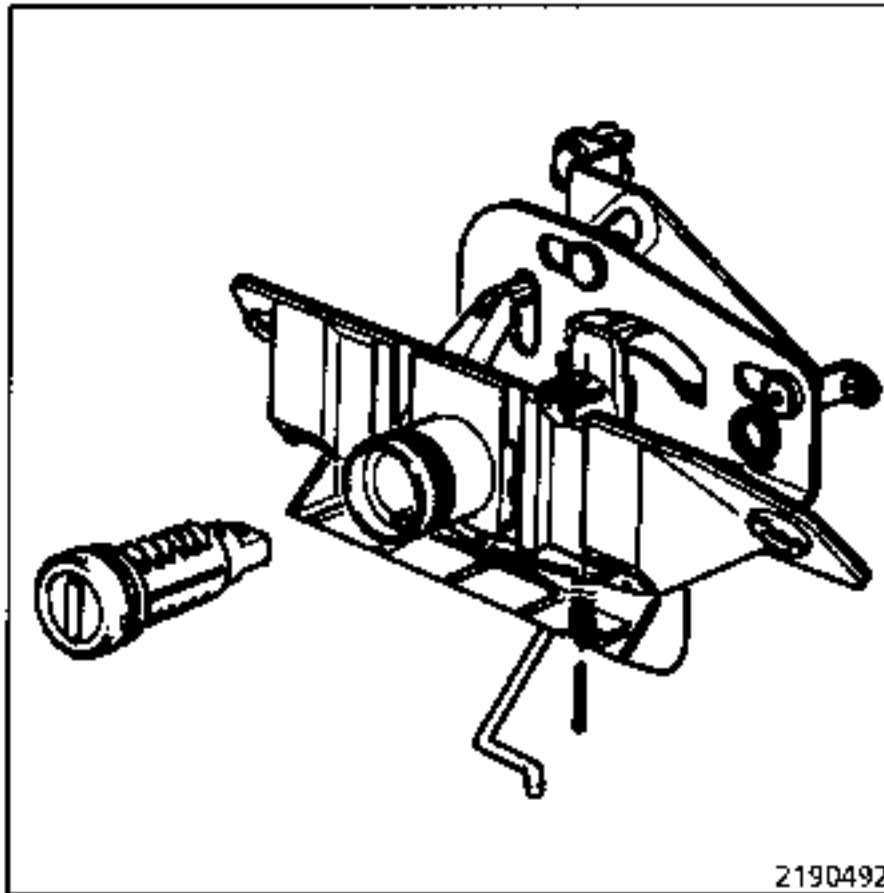

Adjusting the striker plate

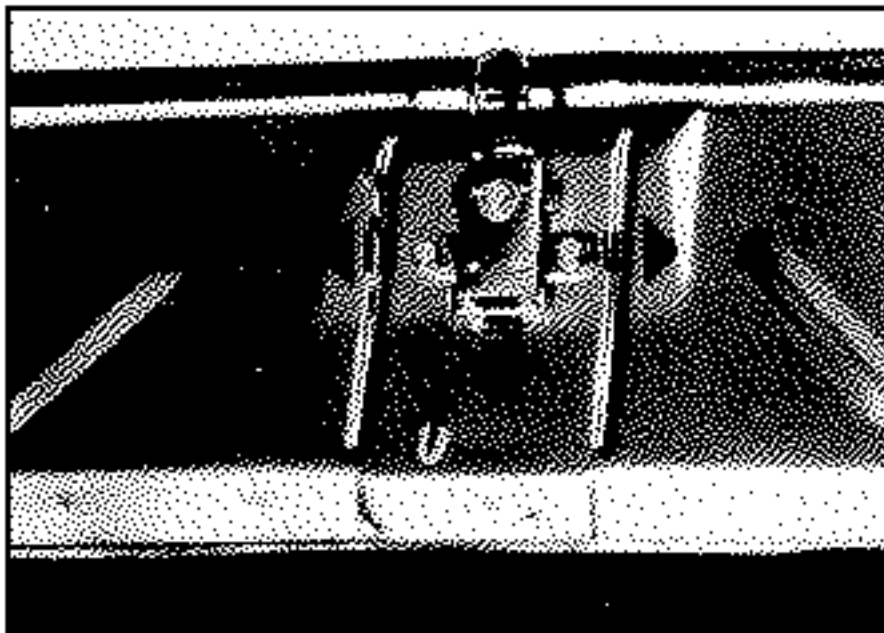

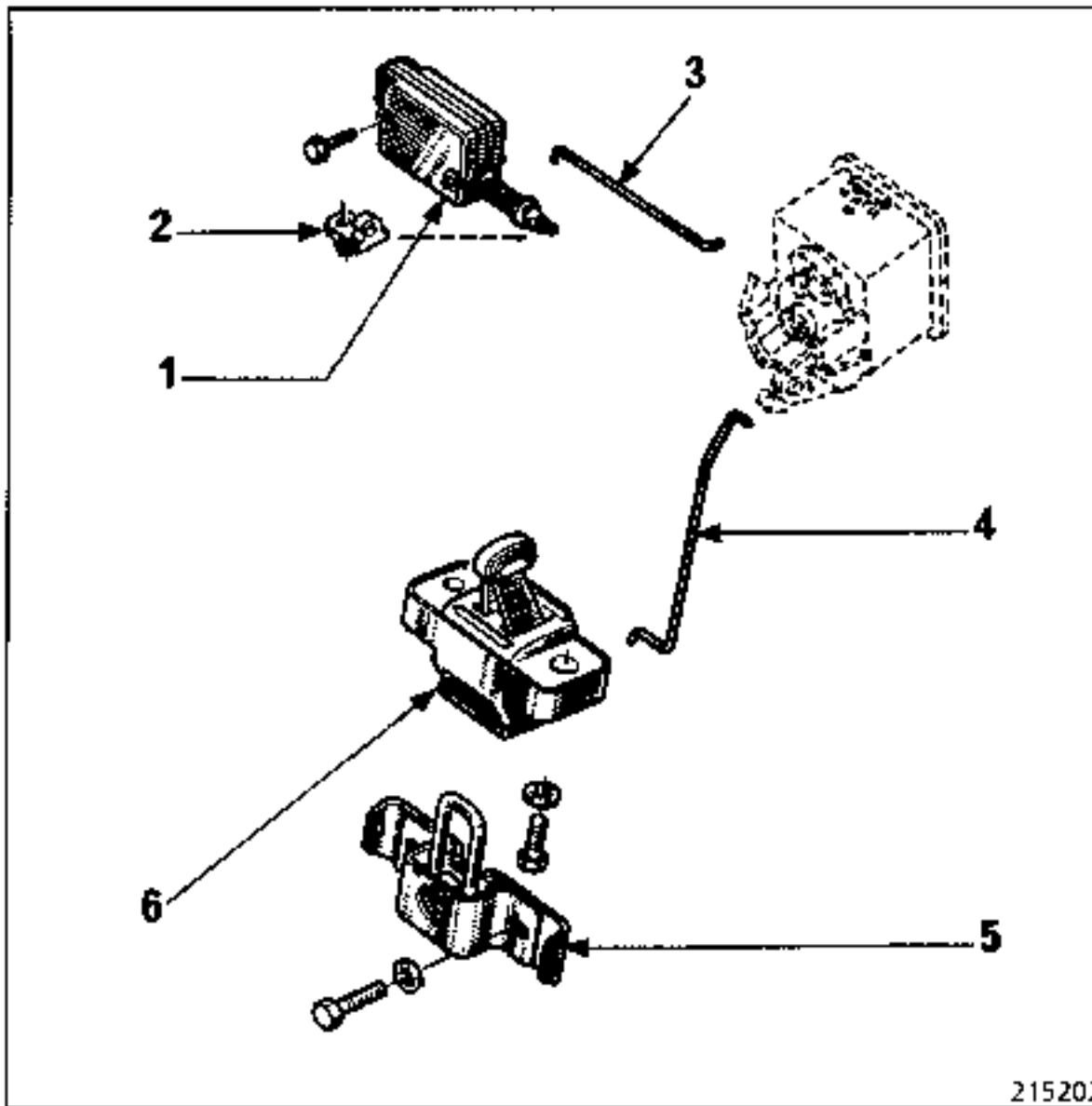

- 1 Locking motor
- 2 Rod mounting clip
- 3 Locking rod

- 4 Opening rod
- 5 Striker plate
- 6 Lock

215202

Removal

Adjusting the striker plate

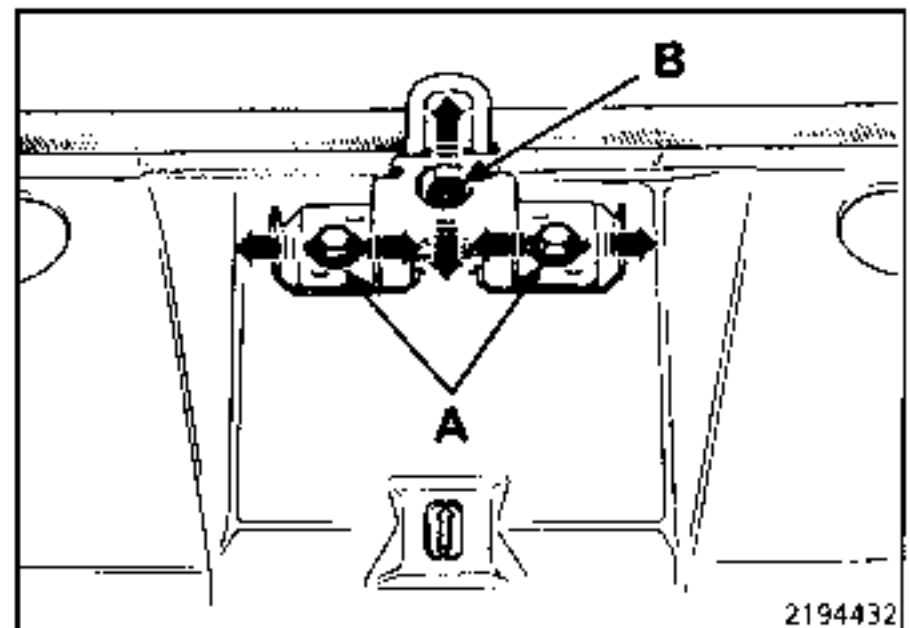
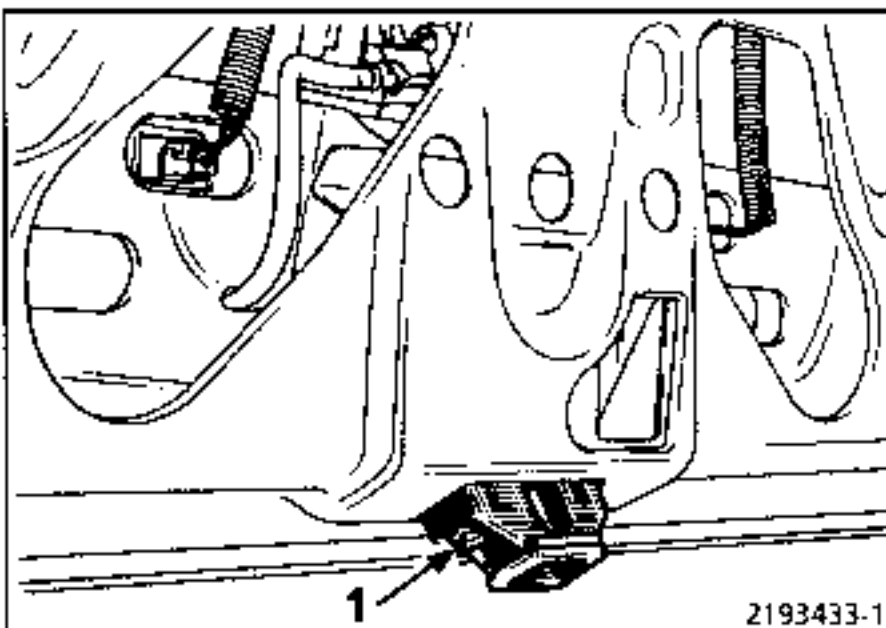

Remove the two screws (1) and pull the lock whilst turning it to disengage the control bolt.

Screw A : side adjustment
Screw B : height adjustment

NOTE : The vertical position of the striker plate is self-adjusting (no shims).

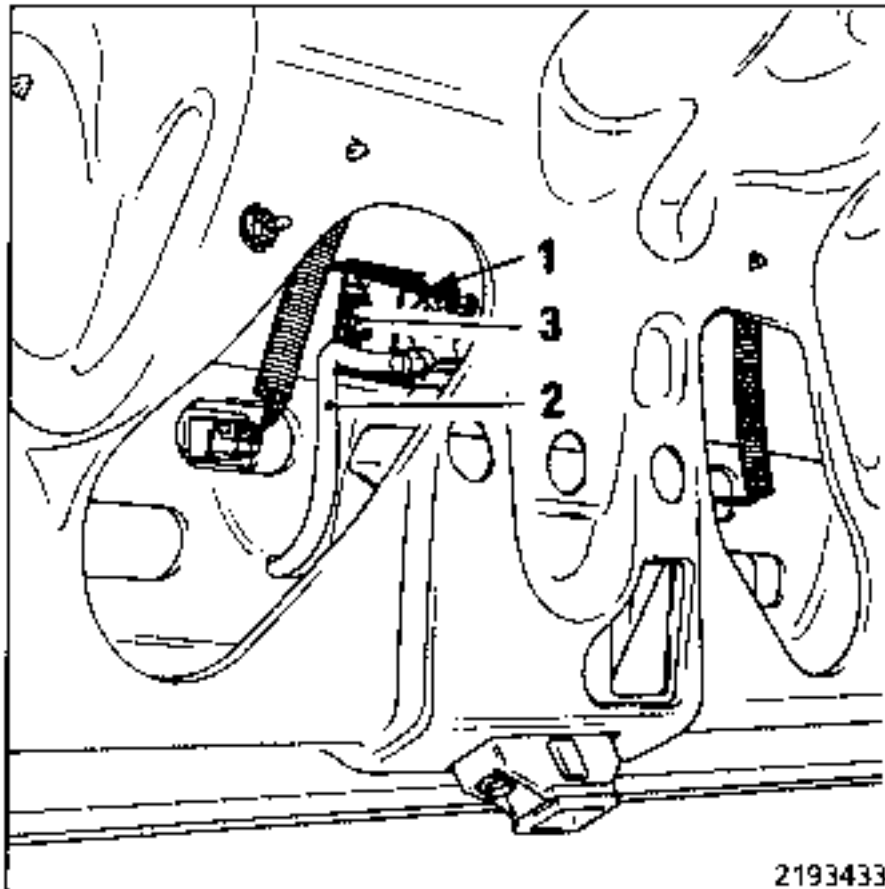

Unclip :

- the locking control rod (1),
- the opening control rod connected to the lock.

Disconnect the water drainage hose (2) and remove clip (3) holding the lock barrel in place.

Remove the lock barrel from the outside of the boot lid.

Removal

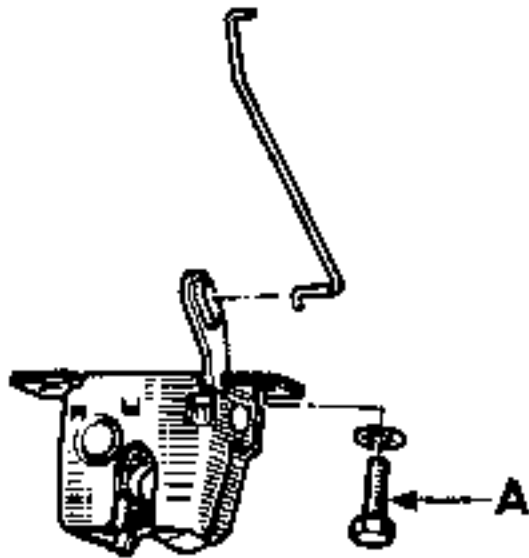

215203

Remove the two screws (A) and pull the lock whilst turning it to disengage the control rod.

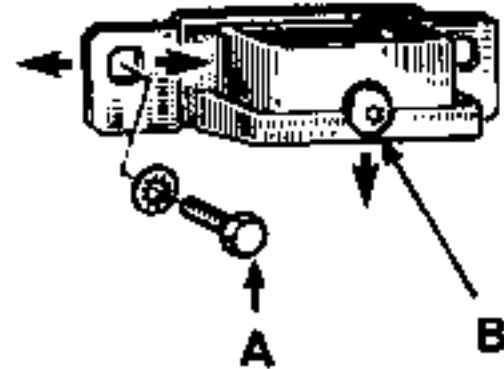

215204

Screw A : side adjustment
Screw B : height adjustment

B48 Tailgate lock barrel

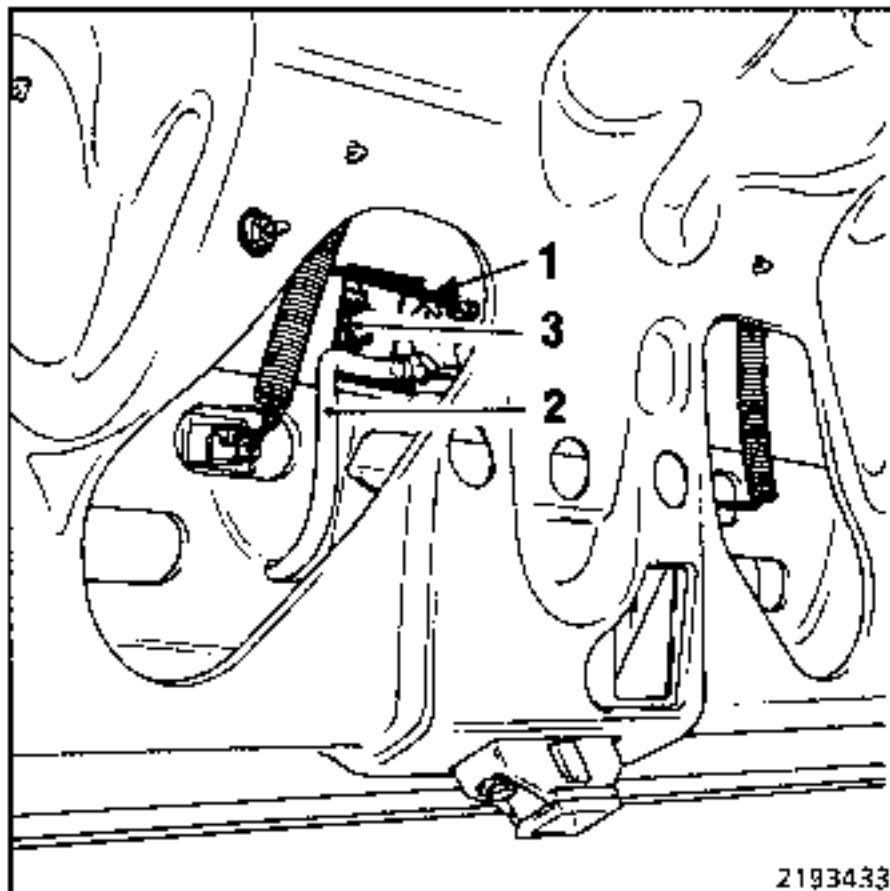

2193433

Unclip :

- the locking control rod (1),
- the opening control rod connected to the lock.

Disconnect the water drainage hose (2) and remove clip (3) holding the lock barrel in place.

Remove the lock barrel from the outside of the boot lid.

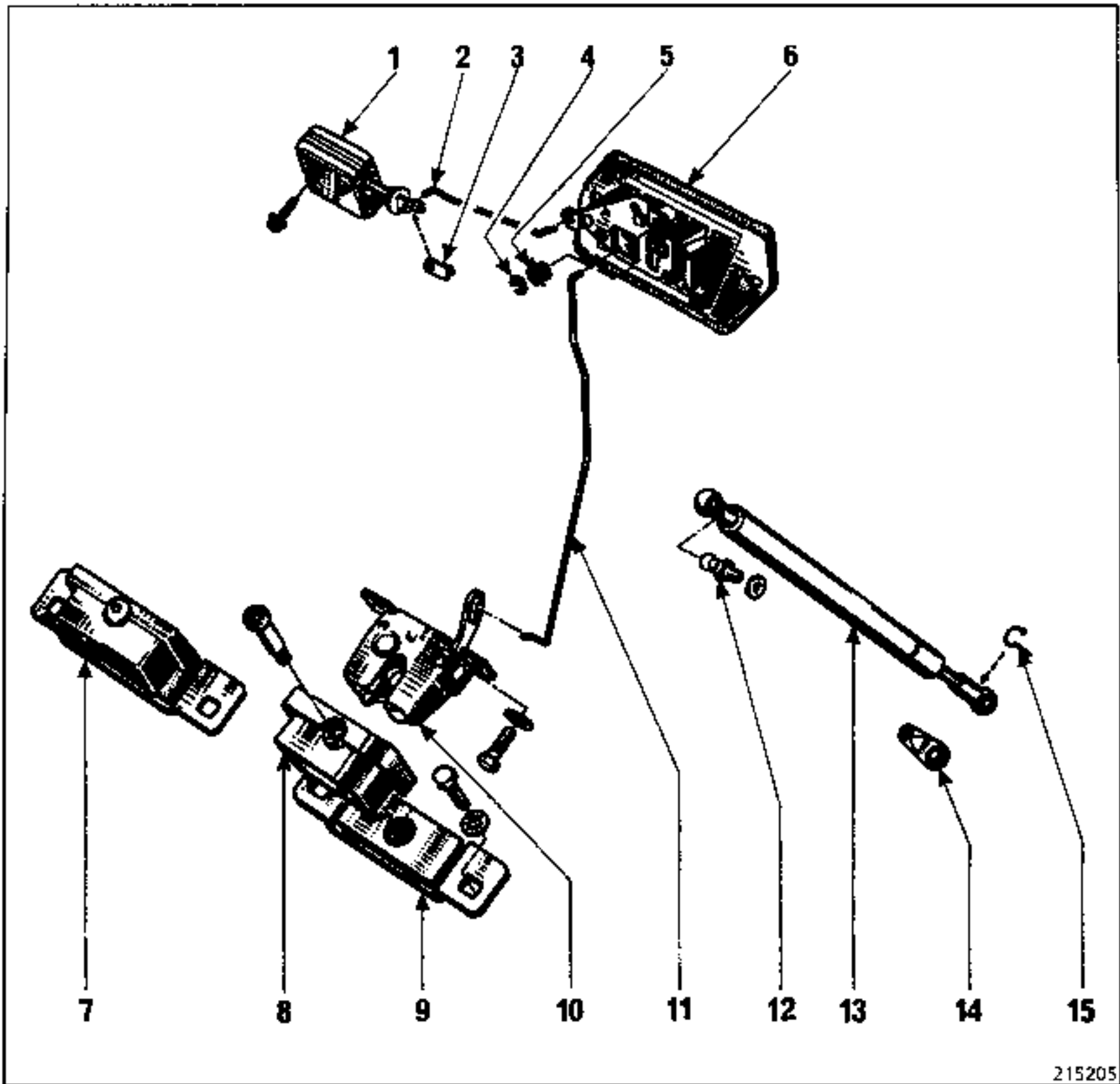

215205

- 1 Locking motor
- 2 Locking rod
- 3 Rod mounting clip
- 4 Circlip
- 5 Return spring
- 6 External control
- 7 Striker plate assembly

- 8 Striker plate
- 9 Left-hand plate
- 10 Lock
- 11 Opening rod
- 12 Pivot pin
- 13 Strut
- 14 Hinge
- 15 Clip

Removing the lock

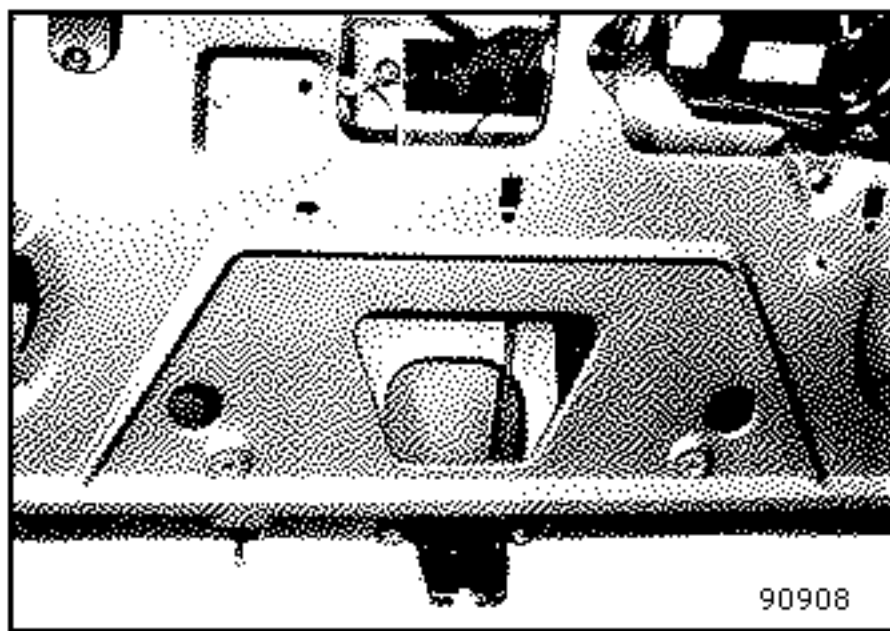

Remove the internal trim from the tailgate.

Remove the two screws holding the lock.

Remove the lock by unfastening it from the control rod.

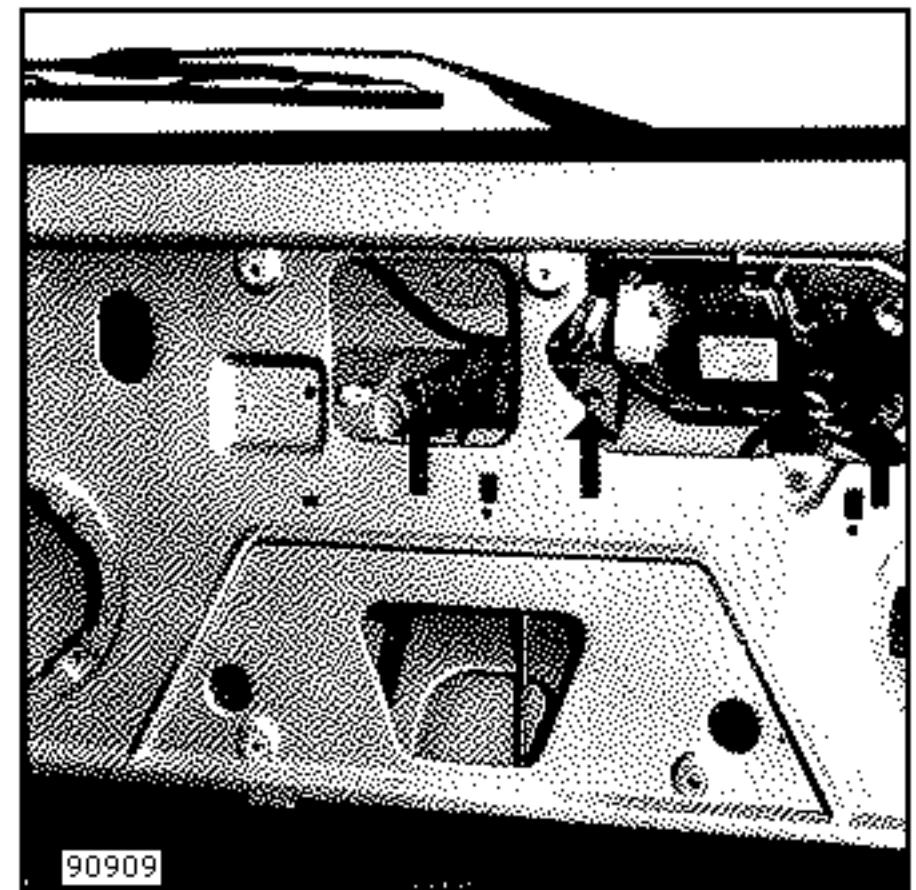

Unclip the electro-magnetic locking rod from the control unit and the control rod from the lock on the handle.

Remove the four nuts holding the number plate lighting moulding.

Disconnect the number plate lights.

Removing the lock barrel

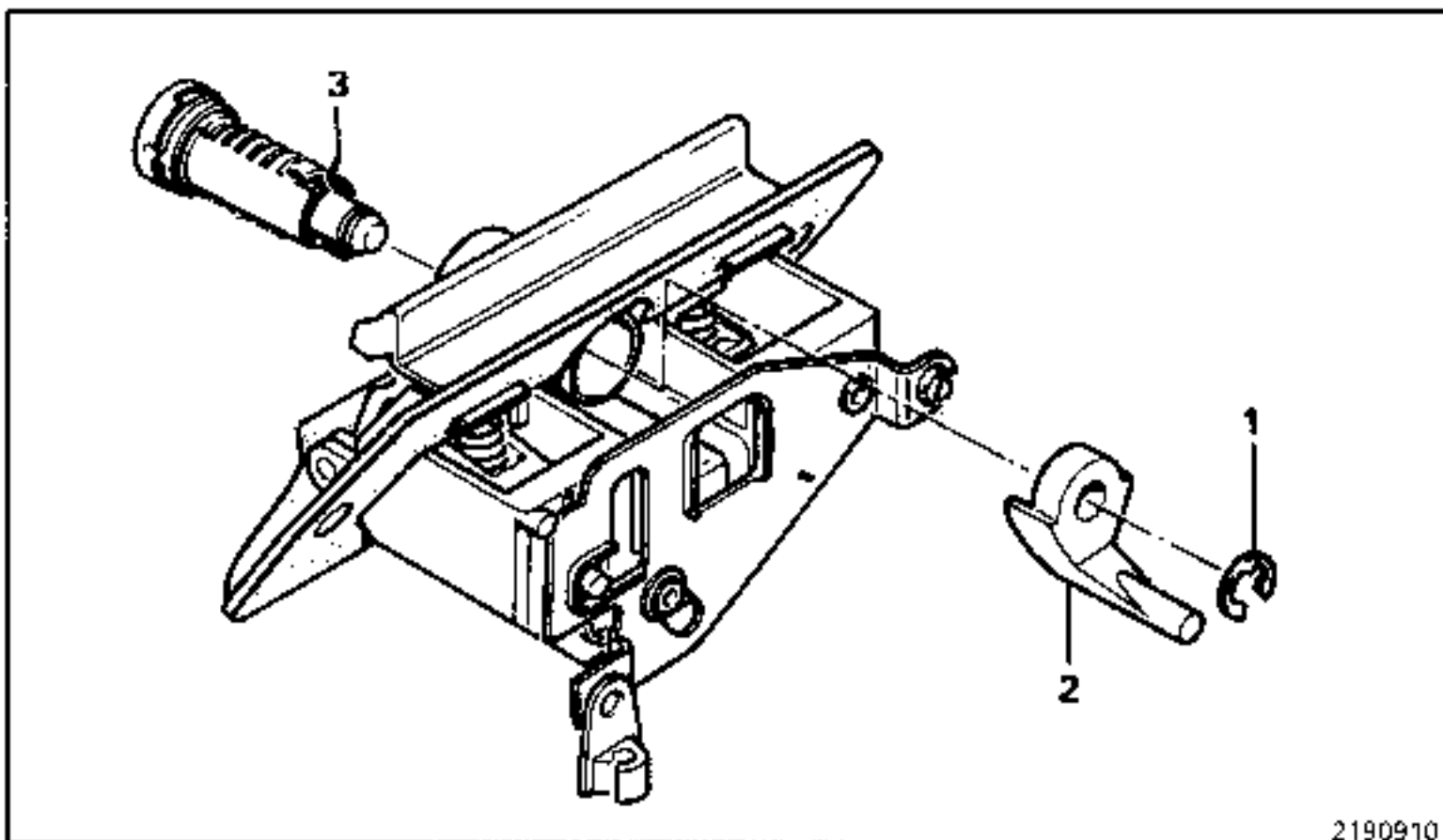

Remove clip (1), disengage control finger (2) and take the lock barrel out, moving it backwards.

NOTE : Make sure spring (3) does not jump out when the lock barrel is removed. This spring enables the lock barrel to return to its original position after it has turned. Before refitting, fit the spring back in place in the groove in the lock barrel, as shown in the drawing.

Adjusting the striker plate

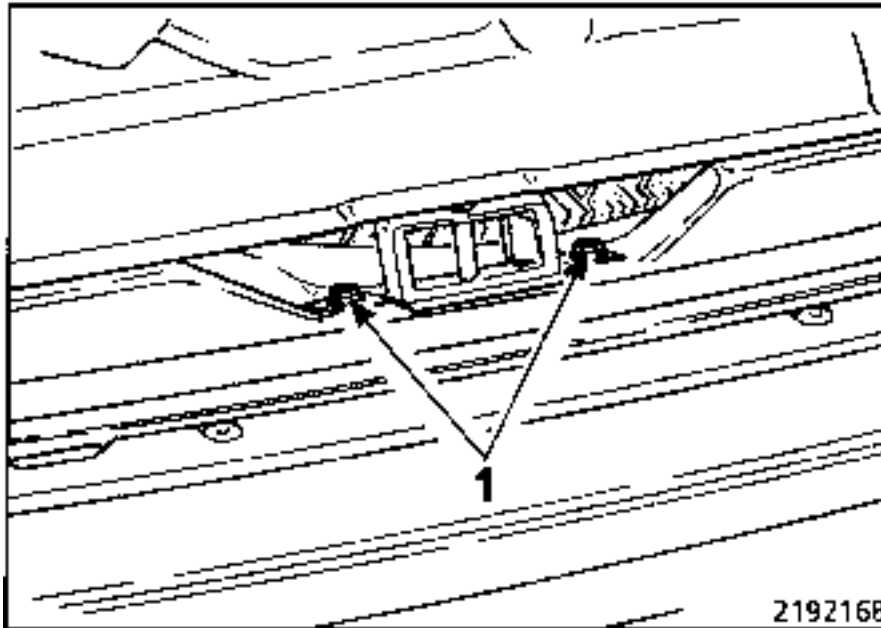

Use the two screws (1) to secure the striker plate in the desired position.

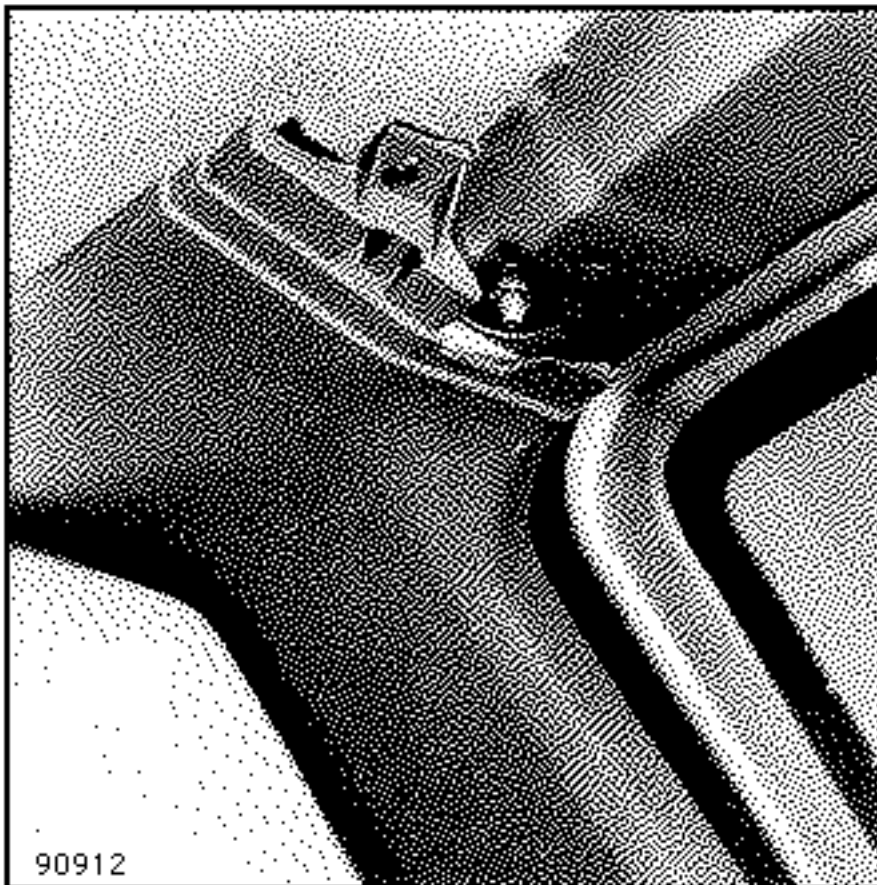

Remove the rear trim strip from the roof and the two nuts holding the hinges.

On refitting, wedges are used to adjust the striker plate so that it is flush with the roof.

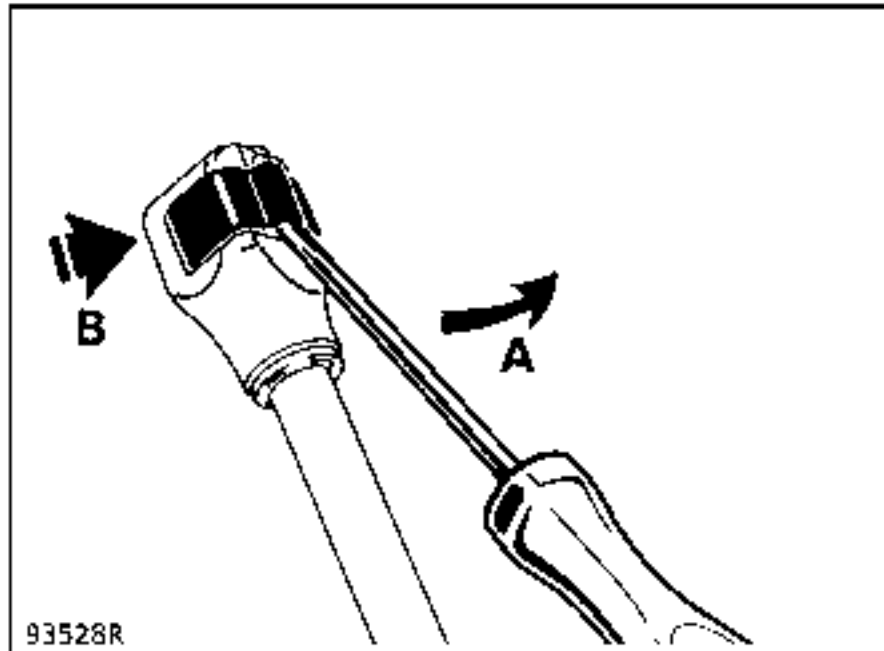
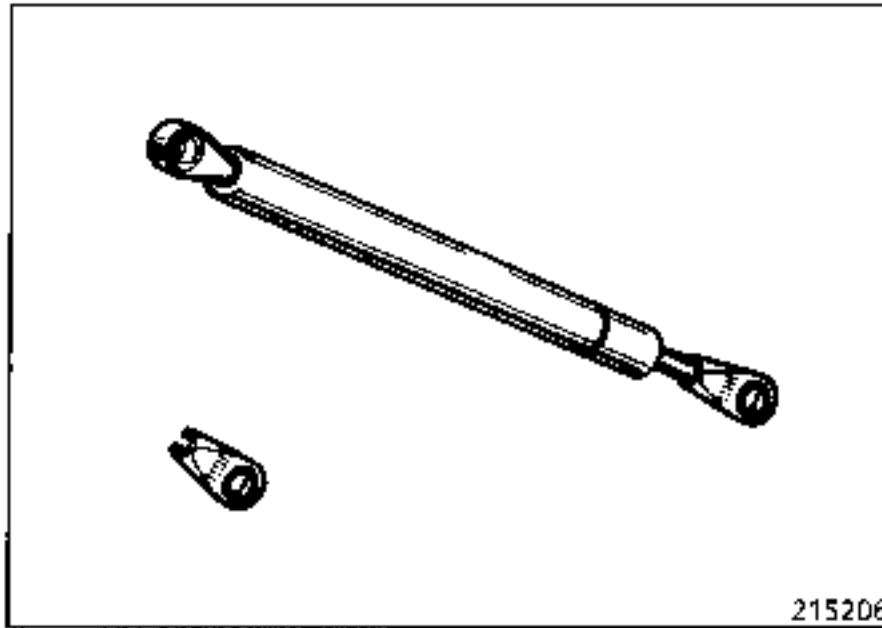

To remove the strut, using a screwdriver move aside the metal clip (A) - but do not remove it - and take the pivot pin out of its location.

If the clip breaks, the end piece on the strut will have to be replaced, Part No : 77 01 034 613.

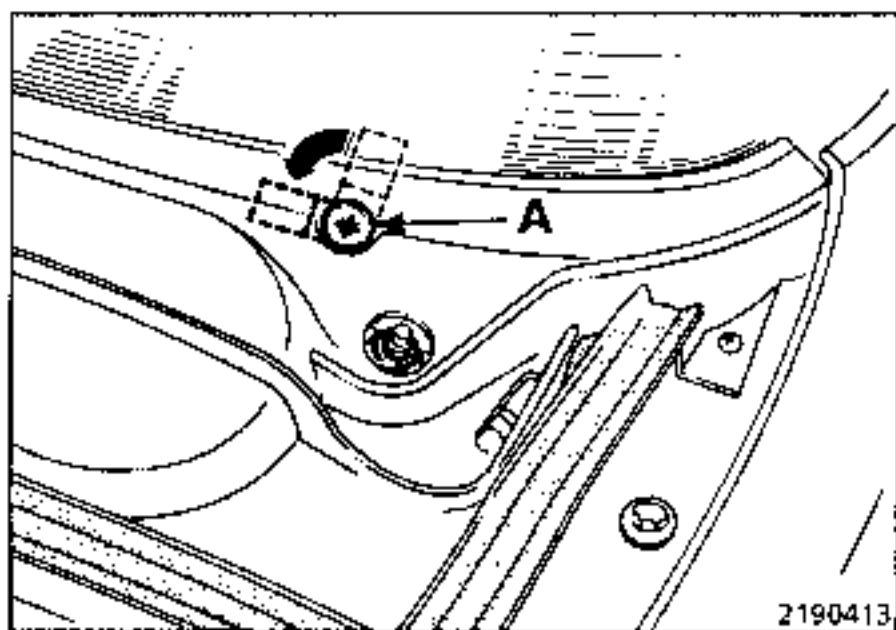
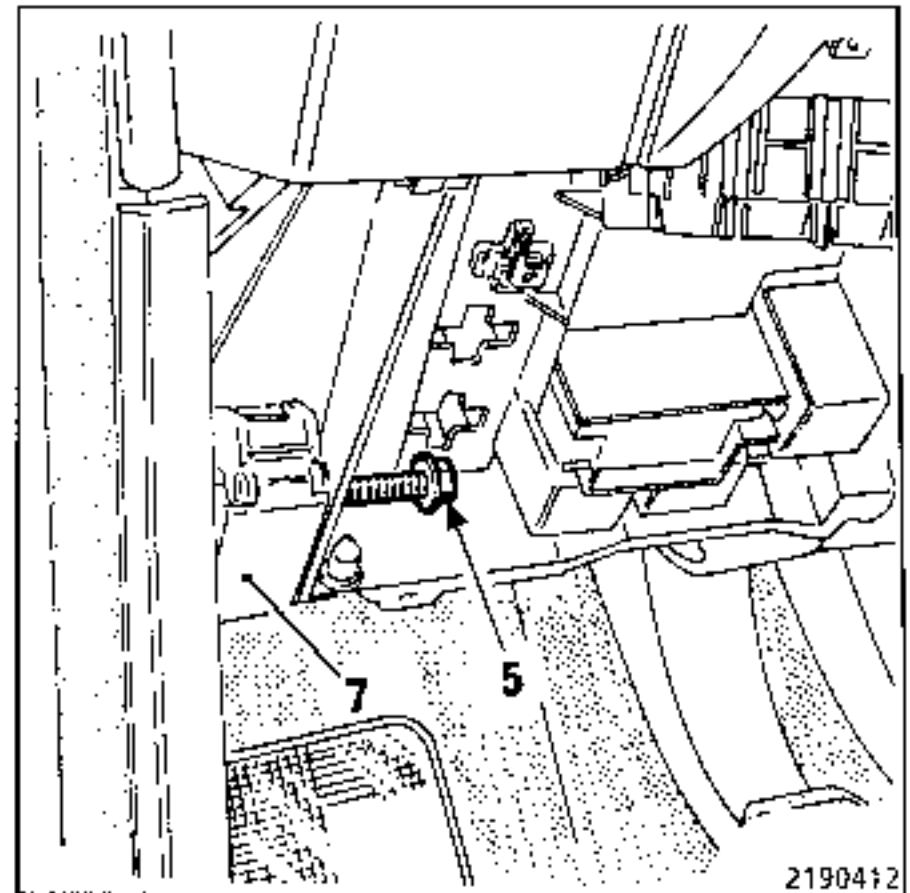
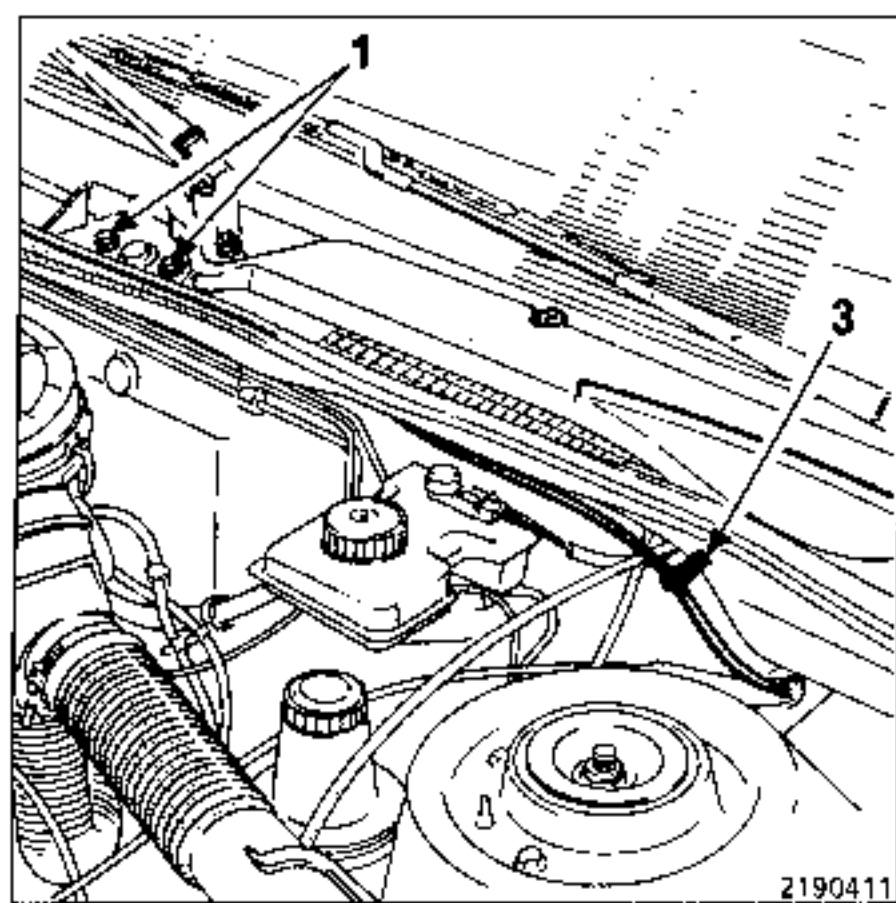

A = 1/4 turn screw

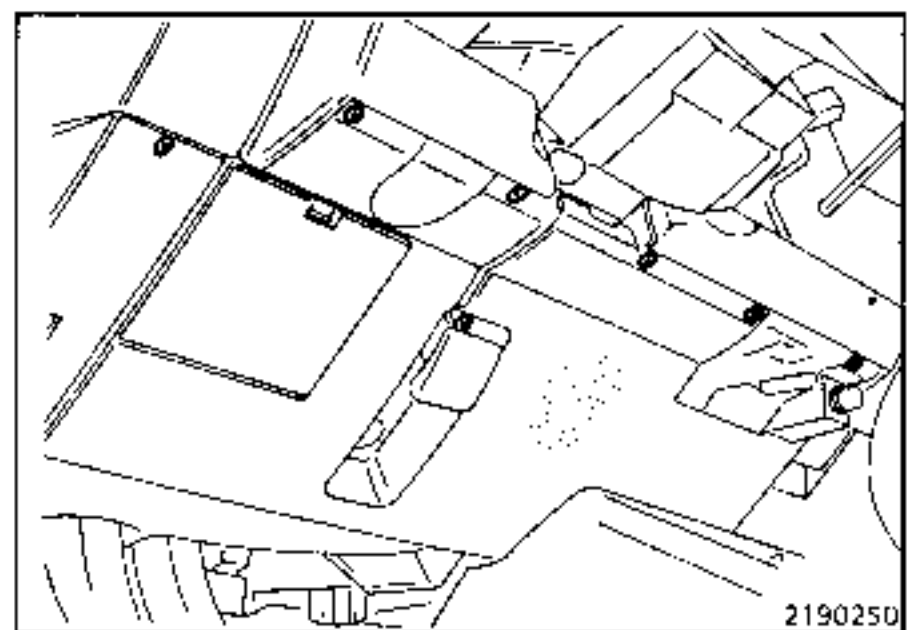

Remove :

- the windscreen wiper blades;
- the scuttle grille,
- the 2 screws (1) from the striker plate and separate the cable from the striker plate.

Disengage the cable from the rubber and the clip (3).

Remove :

- the lower trim from the dashboard and disconnect the cigar lighter;
- screw (5) securing the release lever;
- control handle (7).

Disengage the cable from the rubber pad reaching it from underneath the dashboard.

Free the cable from the dashboard.

DESCRIPTION OF PARTS

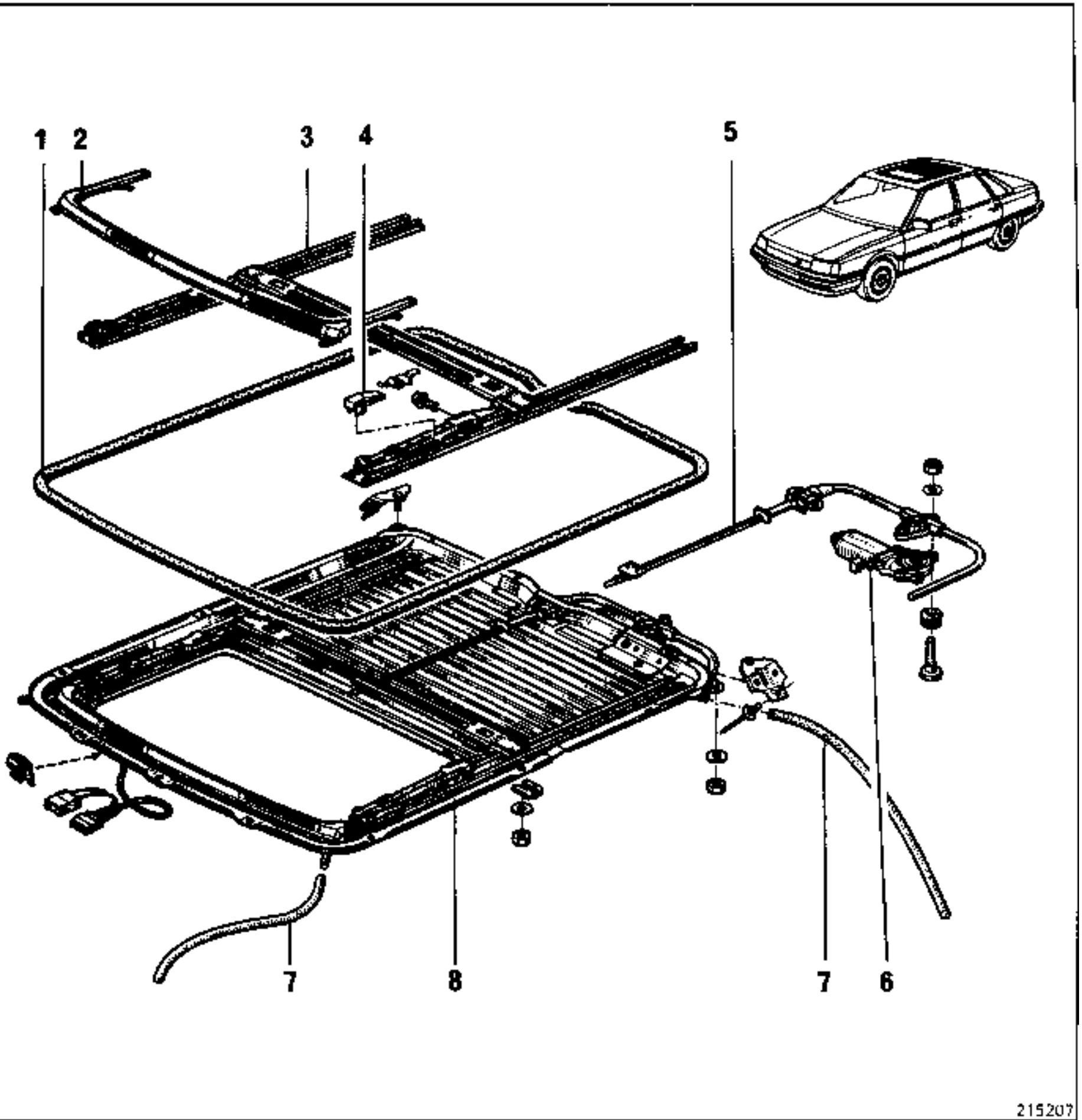

- 1 Seal
- 2 Deflector assembly
- 3 Sunroof control
- 4 Raising ramp
- 5 Control cable assembly
- 6 Sunroof motor
- 7 Water drainage tube
- 8 Rain channel assembly

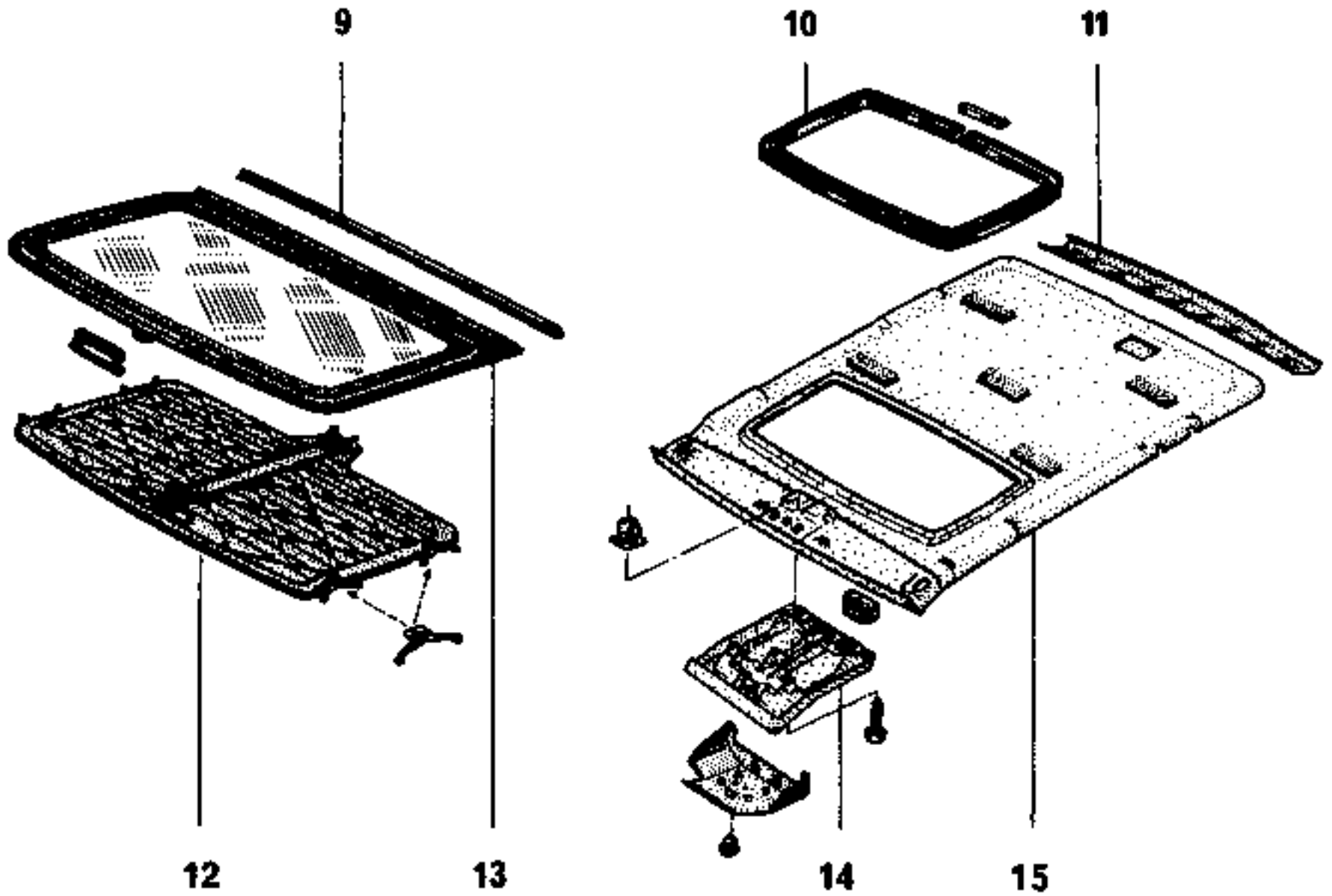

215208

- 9 Moving panel seal
- 10 Finishing profile
- 11 Trim for roof rear cross member
- 12 Screen
- 13 Sliding glass panel
- 14 Roof console
- 15 Headlining

AIR DEFLECTOR

Removal

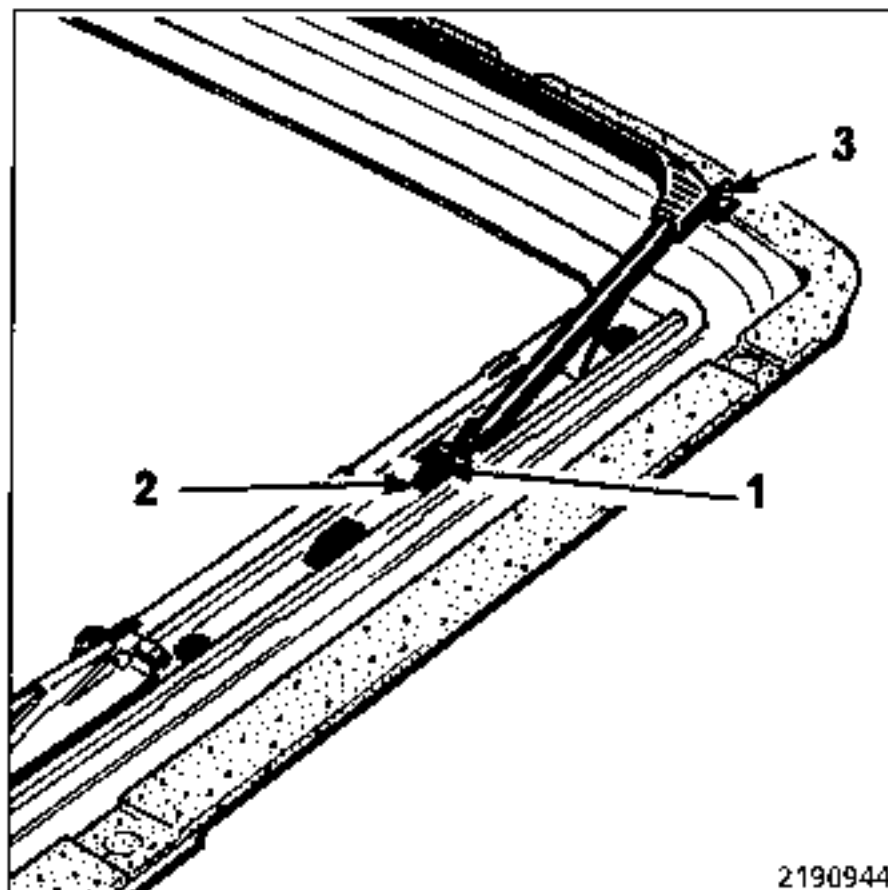

Move the sliding panel into the "open" position.

Remove the 2 screws (1) securing clips (2).

Remove the deflector by disengaging stops (3).

RAIN CHANNEL ASSEMBLY

Removal

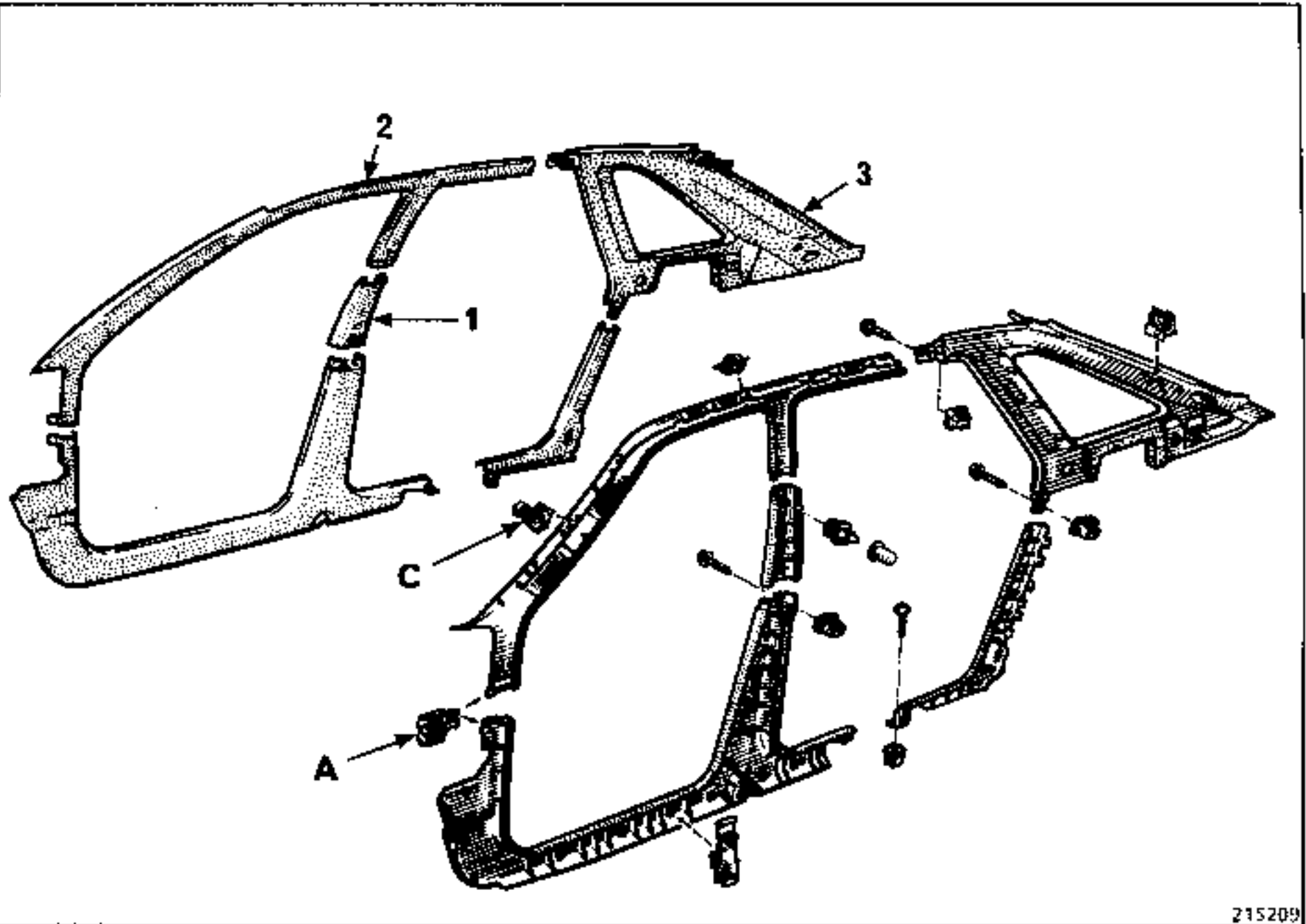

215209

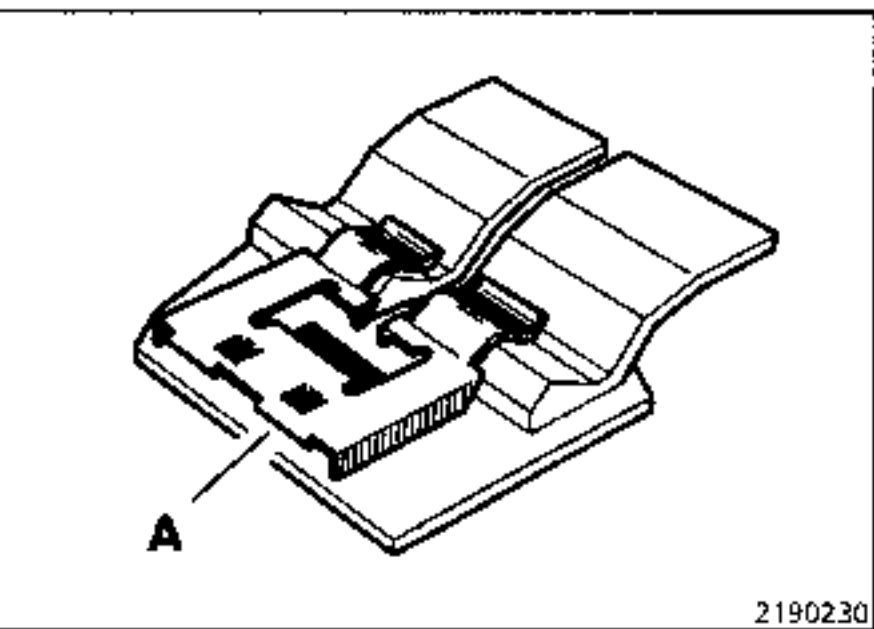

2190230

(A) Snap mounting

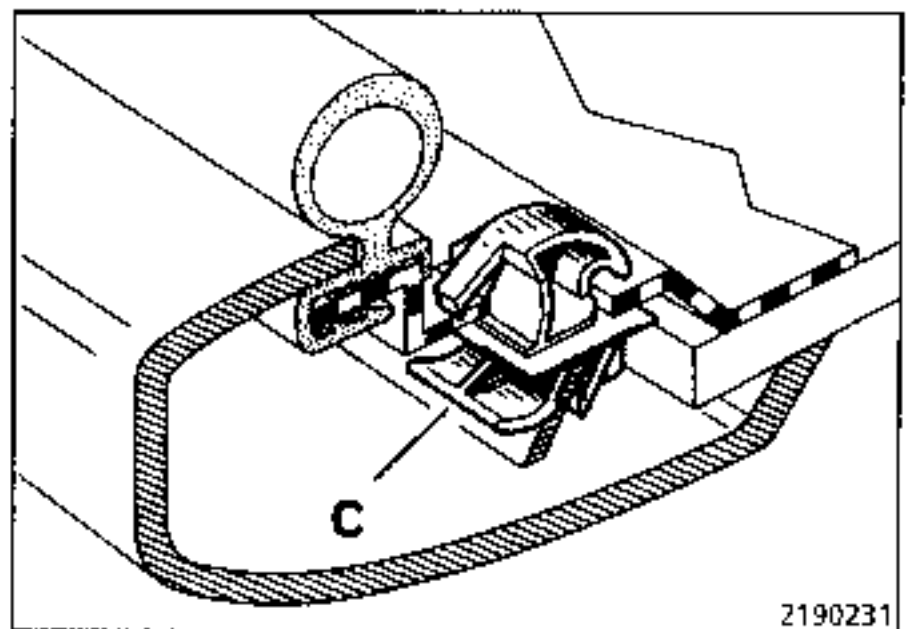

2190231

(C) Snap mounting

Remove :

- the grab handles,
- the internal trim from the body sides (1), (2), (3),
- the trim from the roof rear cross member,
- the roof console,
- the sun visors.

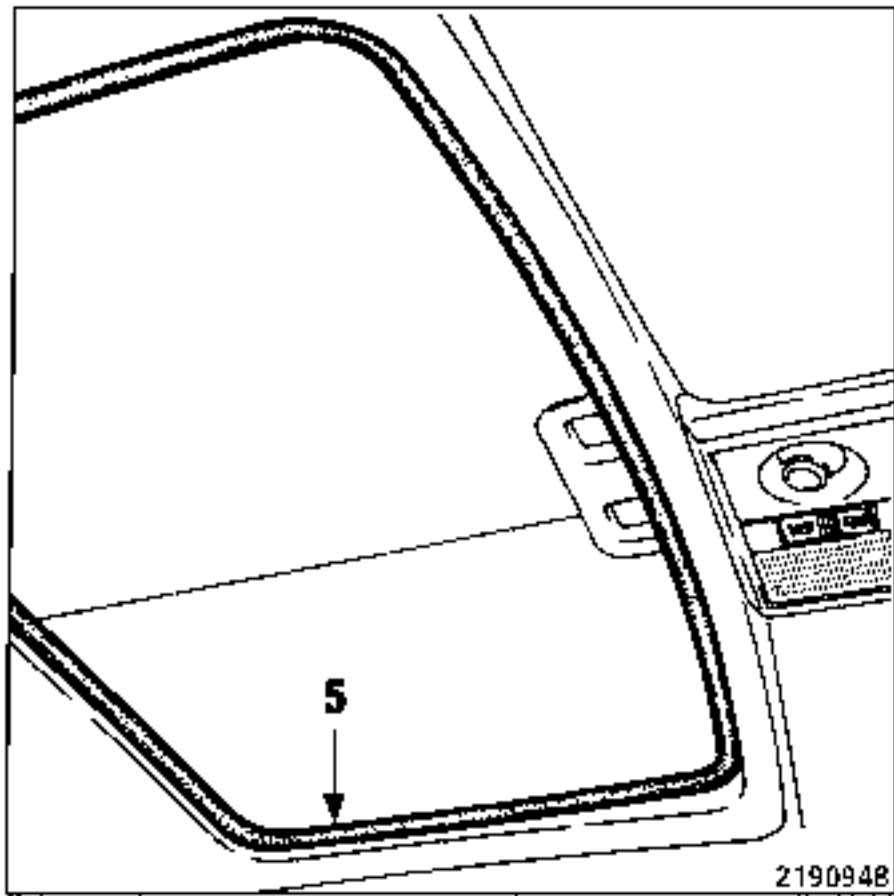

2190948

Open the screen and the glass panel.

Remove the central clip from the finishing profile (5).

Remove the finishing profile by taking it out carefully (this part is fragile).

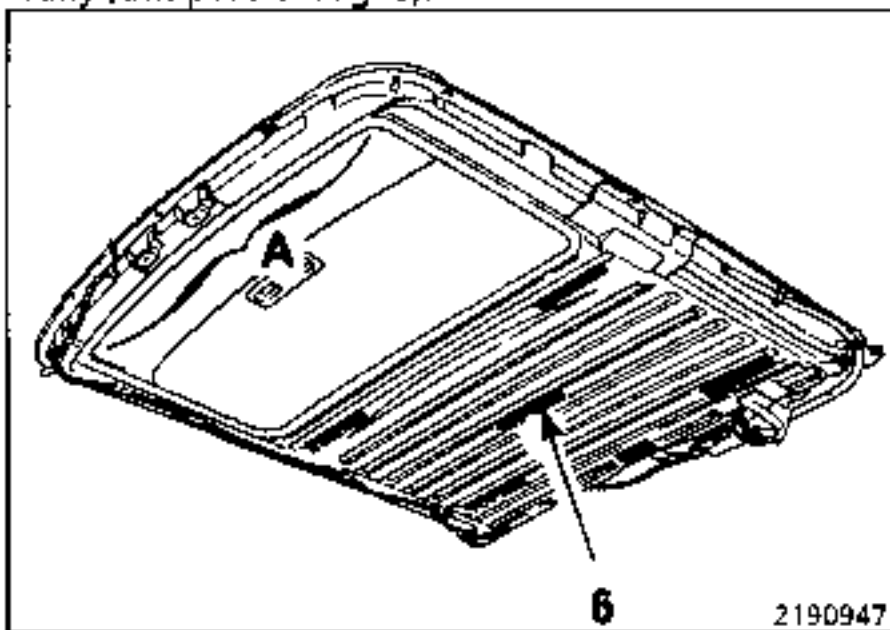

2190947

Remove the headlining. To do this, unstick the headlining using a blade in part (A) and unfasten it from the 6 "velcro" strips (6).

Take out the headlining through the tailgate frame.

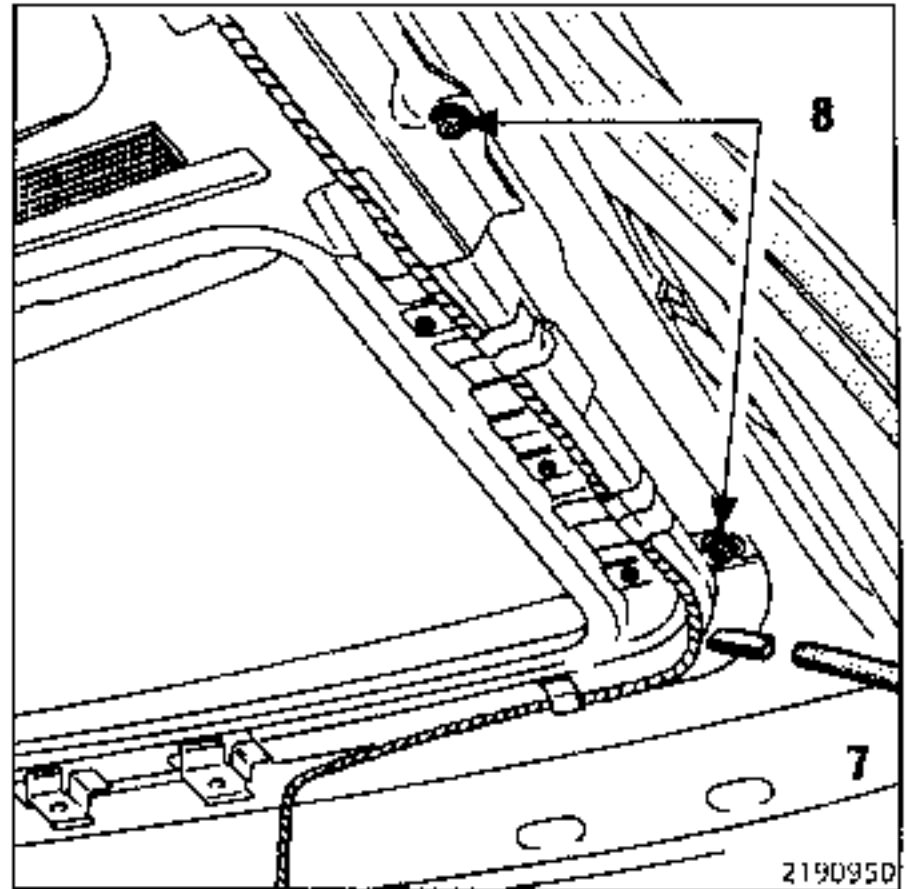

2190950

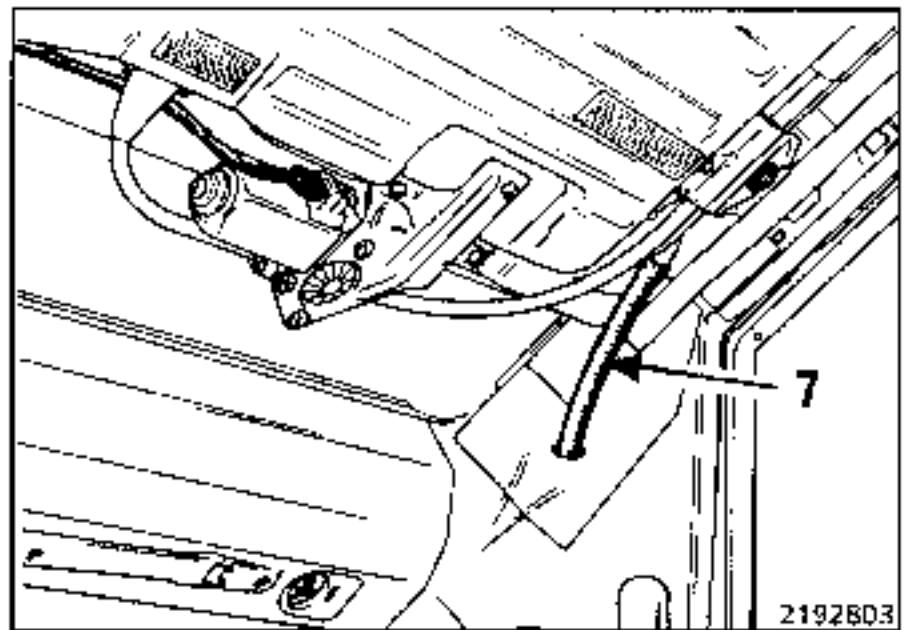

2192803

Disconnect the motor power supply connector.

Separate the 4 water drainage tubes (7).

Remove the 8 nuts (8) securing the rain channel.

Take out the rain channel through the tailgate frame.

MOTOR

Removal

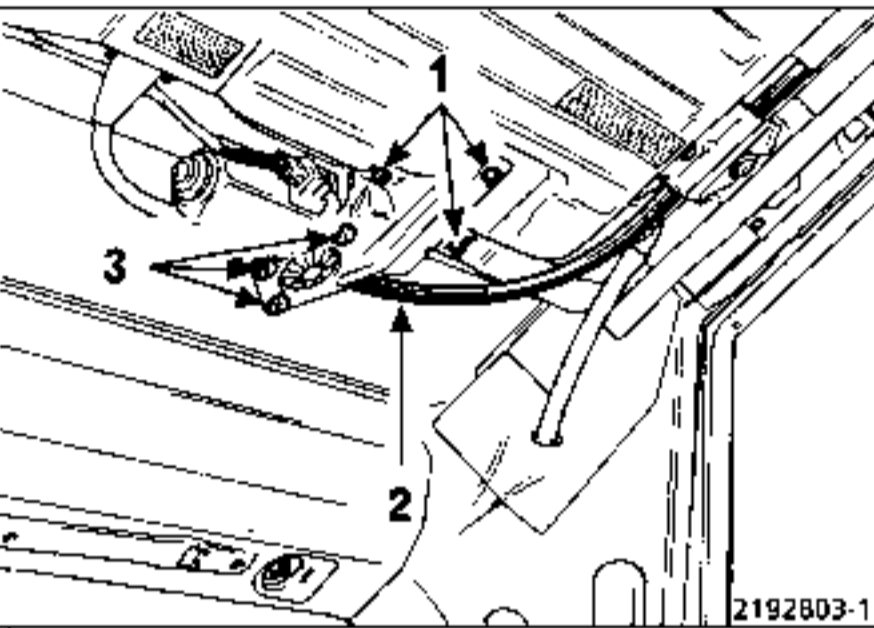

Disconnect the power supply connector from the motor.
Remove the 3 screws (1) holding the motor mounting plate.
Take out the drive cable sheathing (2) from its location.
Remove the 3 screws (3) securing the motor on the plate.
Remove the motor by separating it from the drive cable sheathing.

CONTROL CABLE ASSEMBLY

Removal

NOTE : The rain channel has to be removed in order to perform this operation.

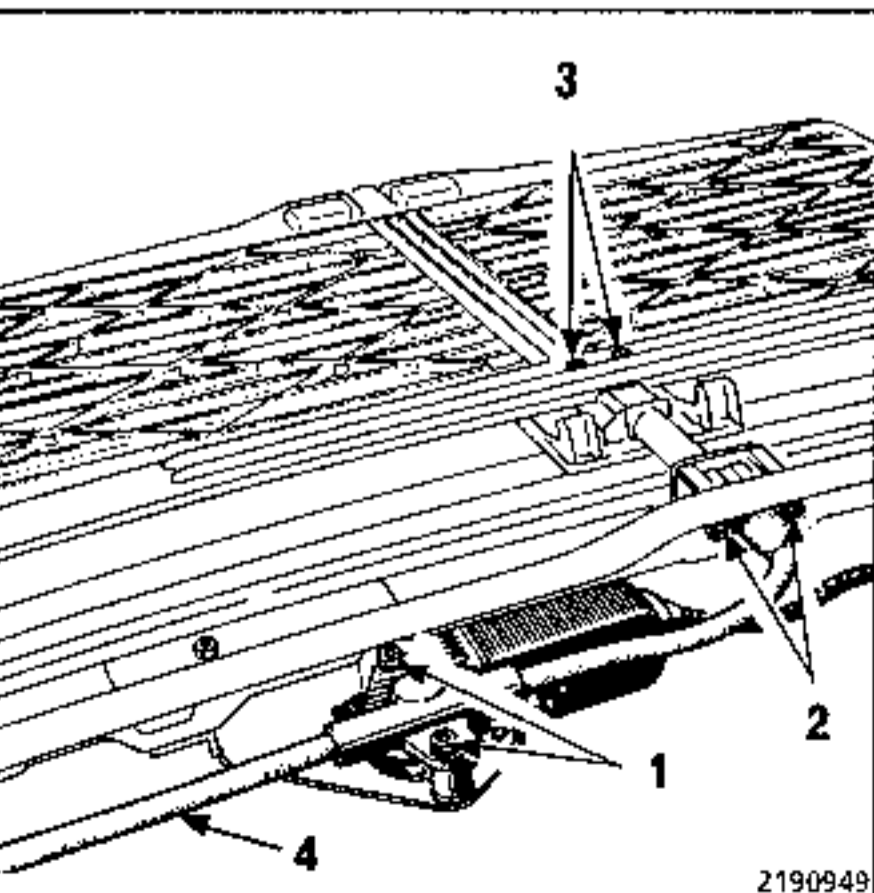

Remove :

- the 2 nuts (1) securing the cable on the motor,
- the 2 nuts (2) securing the sheathing to the rain channel,
- the 2 screws (3) securing the cable end piece to the central cross member,
- the sheathing (4) by separating it from the control cable.

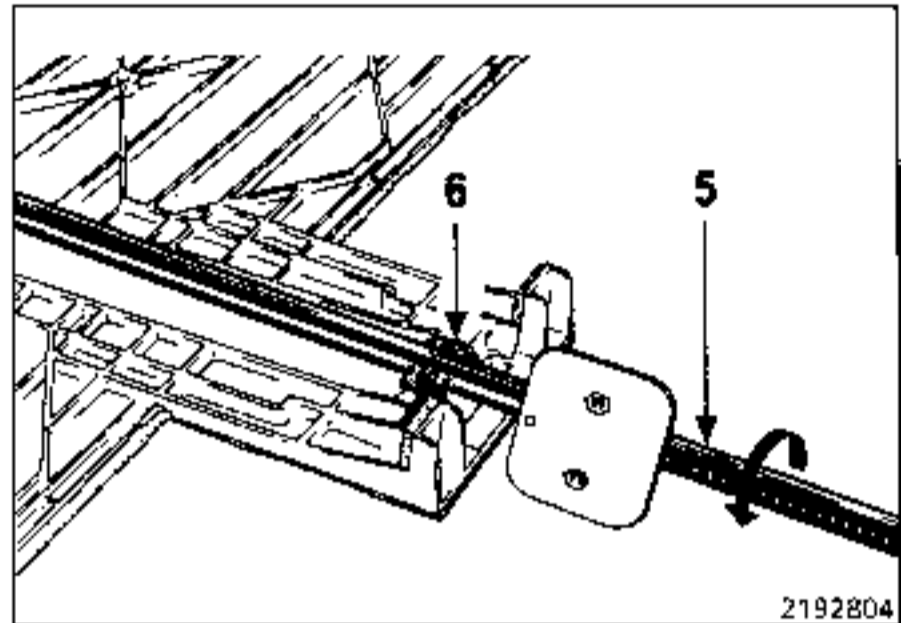

Pivot the guide tube (5) on its shaft around hook (6) to separate it from the screen.

SUNROOF CONTROL MECHANISM

Removal

NOTE : The rain channel has to be removed in order to perform this operation.

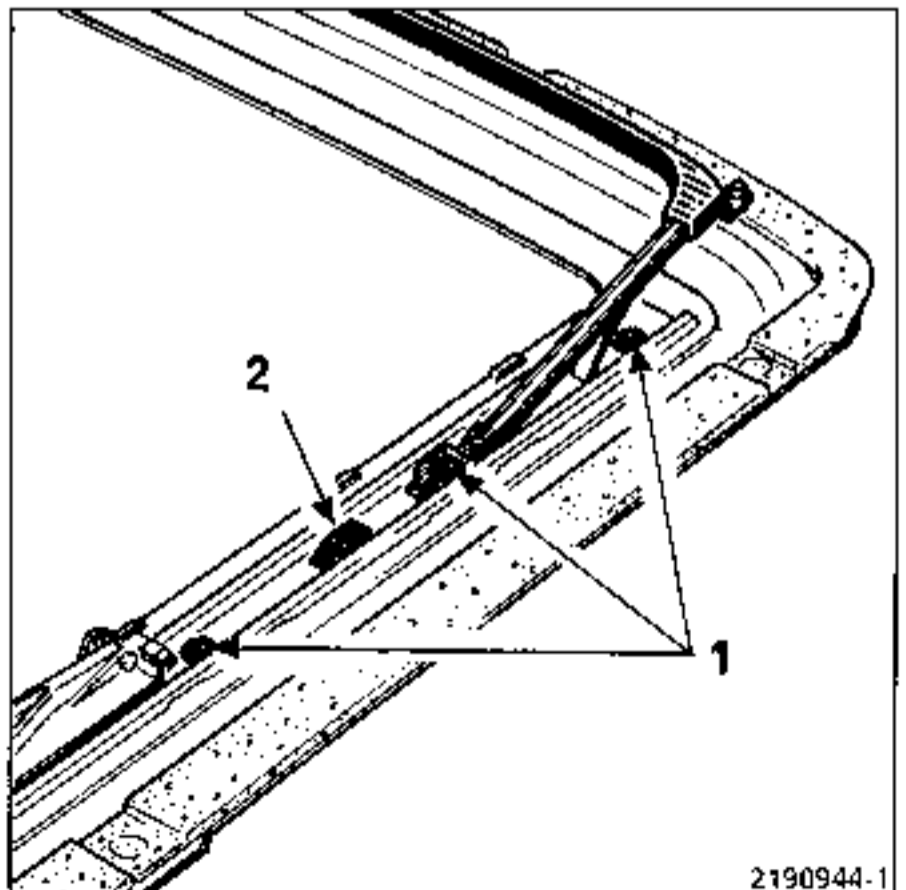

Move the mechanism into the "open" position.
Remove the six screws (1) securing the rails to the rain channel.
Unclip the 2 raising ramps (2).

Remove the 2 screws securing the control cable end piece to the mechanism central cross member.

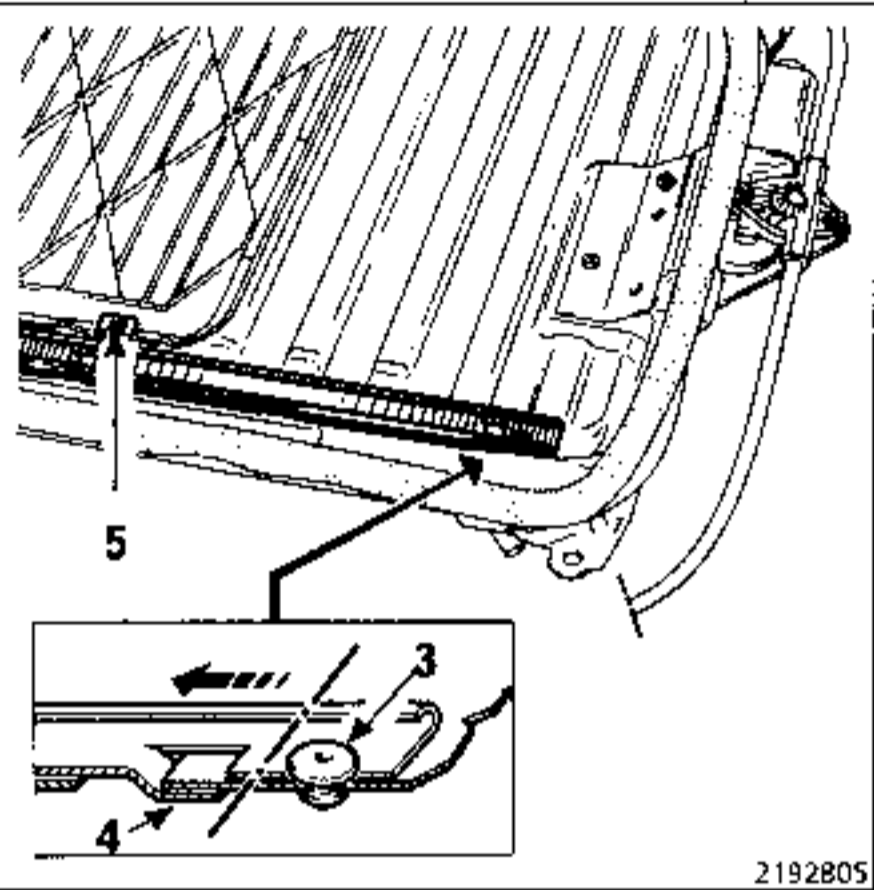

Drill the 2 rivets (3) securing the rails at the rear and remove the mechanism by pulling the rails towards the front to free catches (4).

Hold the screen whilst removing the mechanism in order to free the guide springs (5).

MOVING GLASS PANEL

REMOVAL

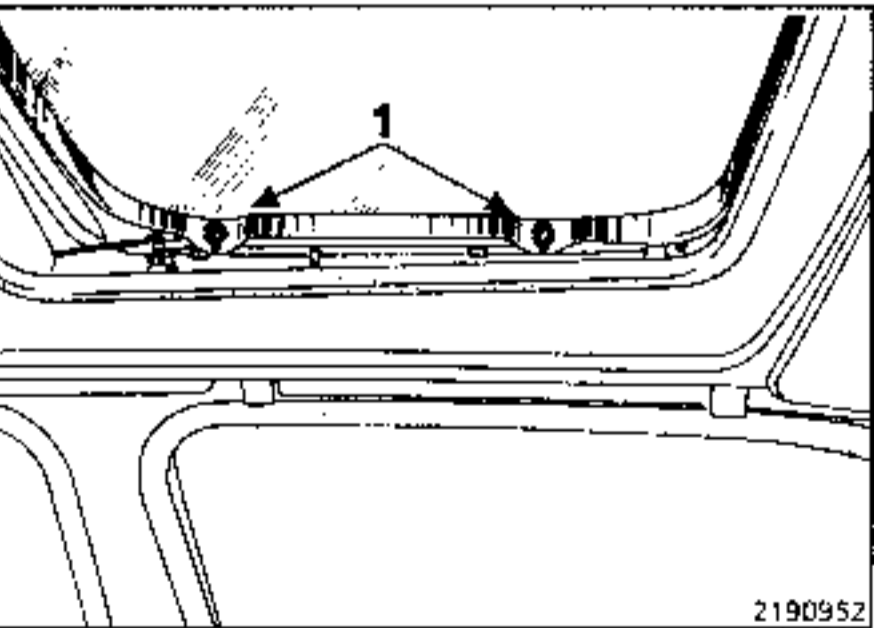

Close the panel.
Remove the 4 screws (1) (stamped BTR).
Use the electric control to move the sunroof backwards.

Tilt the glass panel slightly backwards and take it out from outside the vehicle, moving from the rear towards the front.

REFITTING and ADJUSTING

Place the glass panel on the control mechanism and run up the 4 screws (1) without tightening them.

Move the control to the "closed" position and adjust the alignment of the moving panel with the roof.

Tighten the 4 screws.

Activate the sunroof a number of times in order to check that it is flush and alter the alignment if necessary.

REMOVING THE TRIM

Remove :

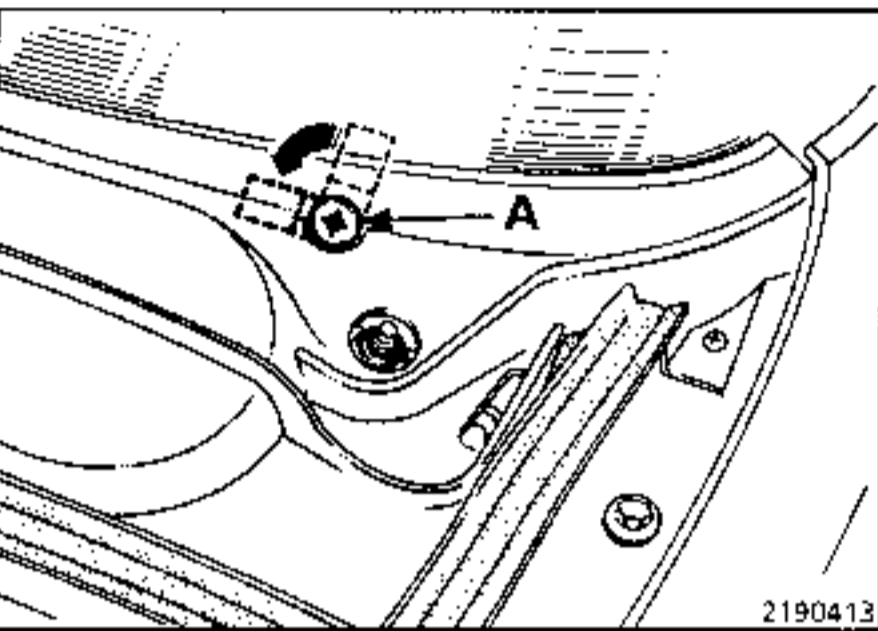

- the windscreen wiper blades,
- the scuttle grille (clips (A) with a cross-head are to be turned 1/4 of a turn),

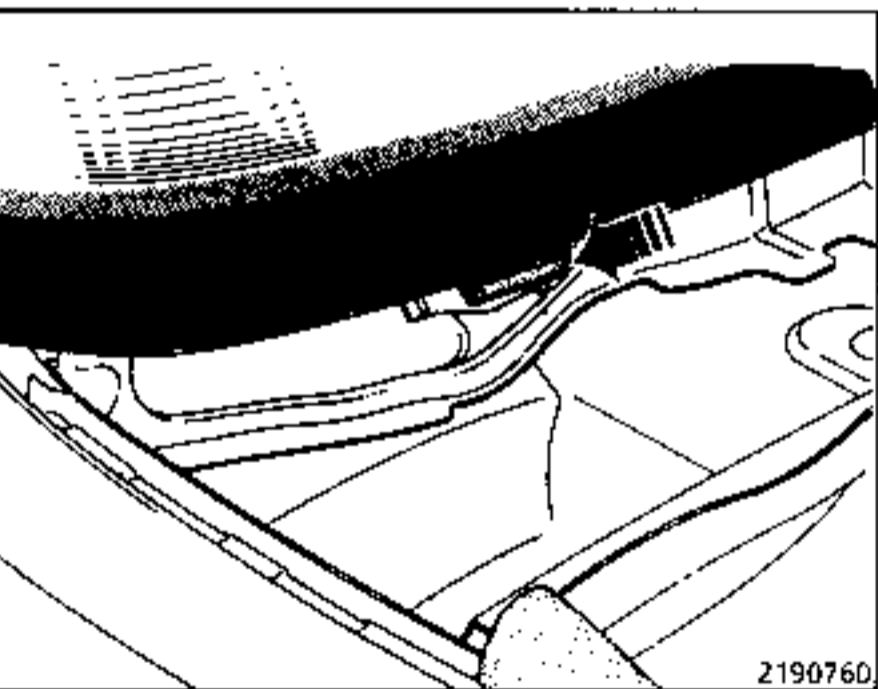

- Unclip the lower stops and remove them.

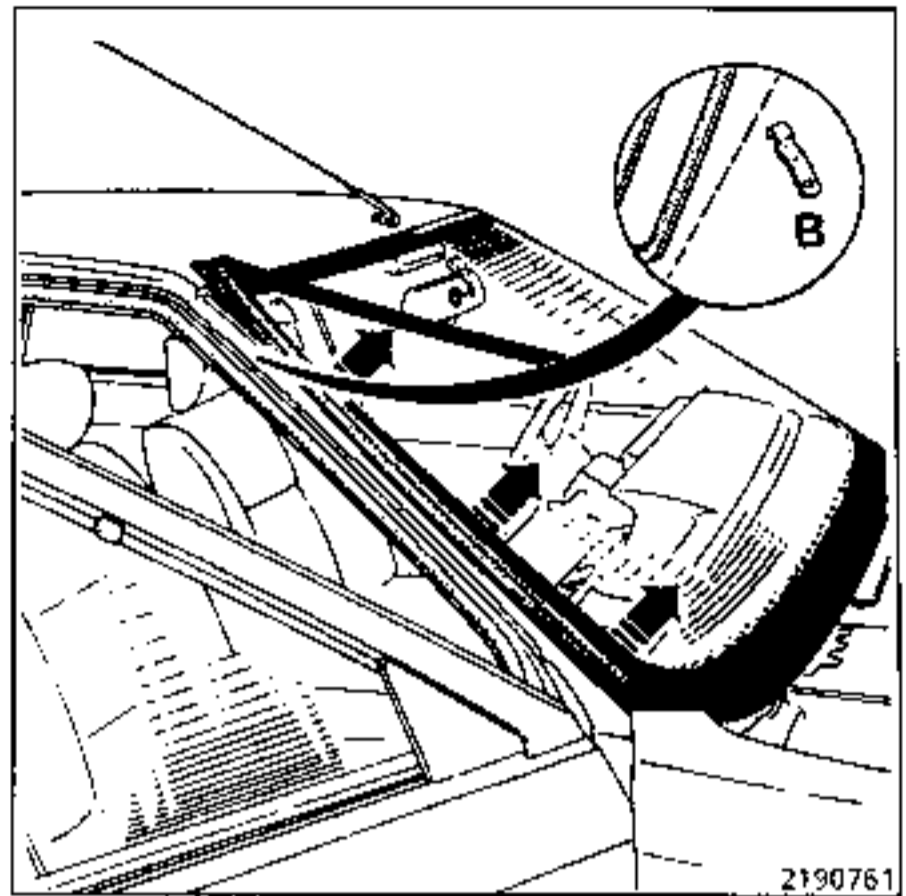

Moulding fastening clip (B).

The mouldings cannot be re-used. They must be replaced.

They are to be bonded over the entire length of the windscreen pillars using glass bonding mastic. To remove the mouldings they must be torn away from the surround.

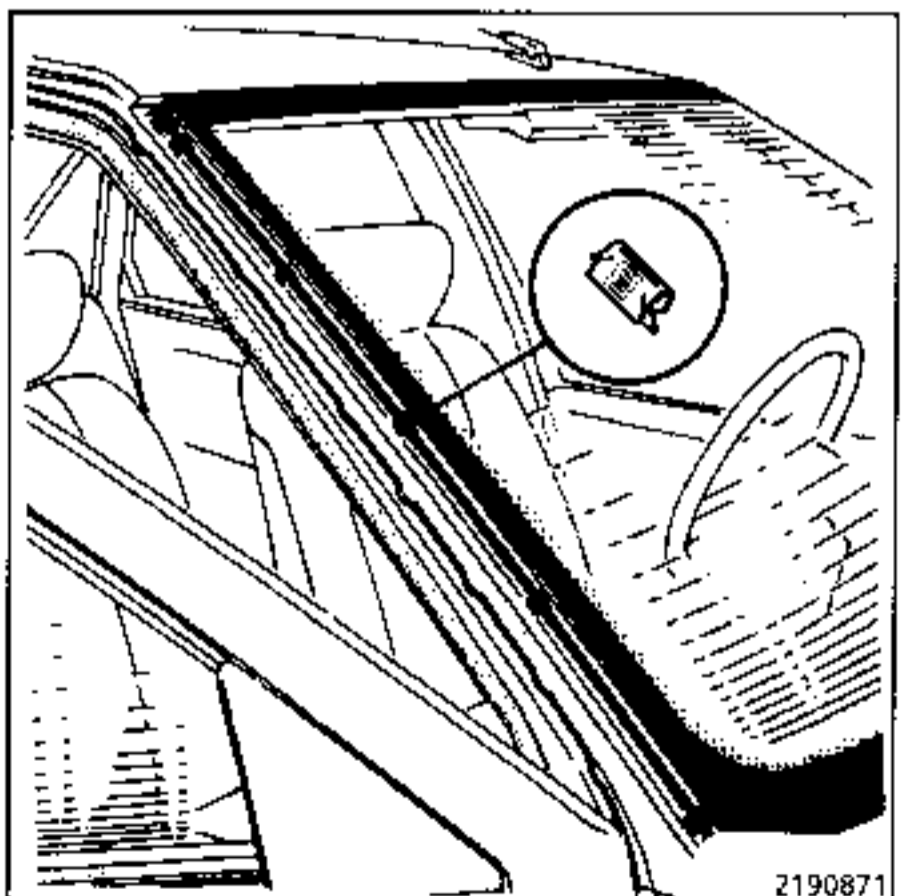

When the mouldings have been removed, 6 holding clips should remain on the aperture in the positions shown in the drawing. If necessary, replace any missing clips (direct the clips so that the spikes are facing outwards).

REMOVAL

Stick a strip of adhesive tape over the front section of the roof in order to protect it.

Check the top edge to see whether there is sufficient clearance between the moulding mounting and the aperture to enable the wire to be passed through over the entire length of the moulding mounting.

If the clearance is not sufficient, remove the moulding mounting. To facilitate its removal it can be heated slightly using a hot air torch.

Fit the dashboard protector in place.

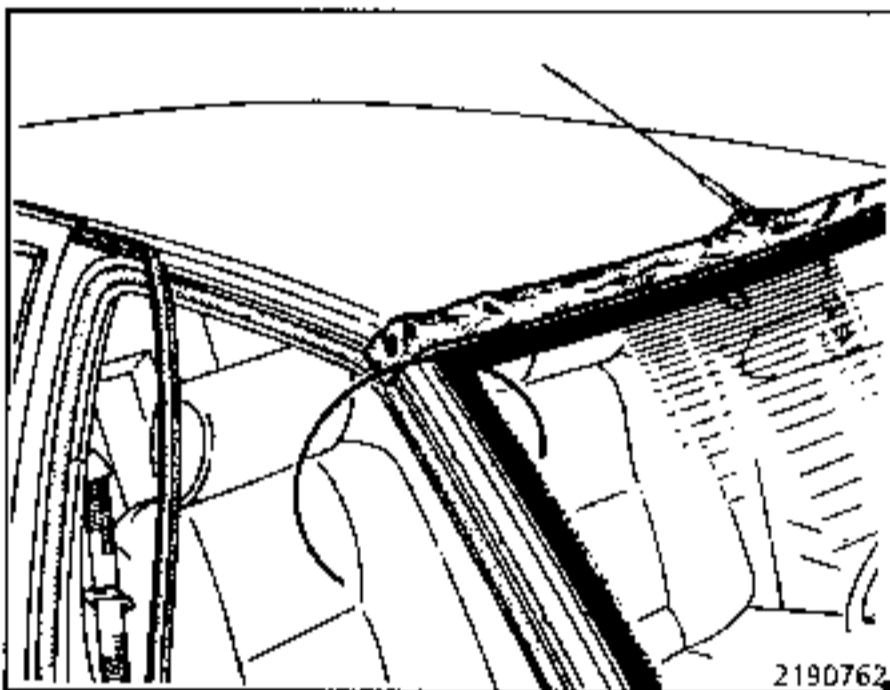

At one of the upper corners pass a piece of steel wire approximately 30 cm long through the mastic bead.

Fit in place the pricker tool and pulling handle.

Cut the mastic bead starting at the two sides and upper edge.

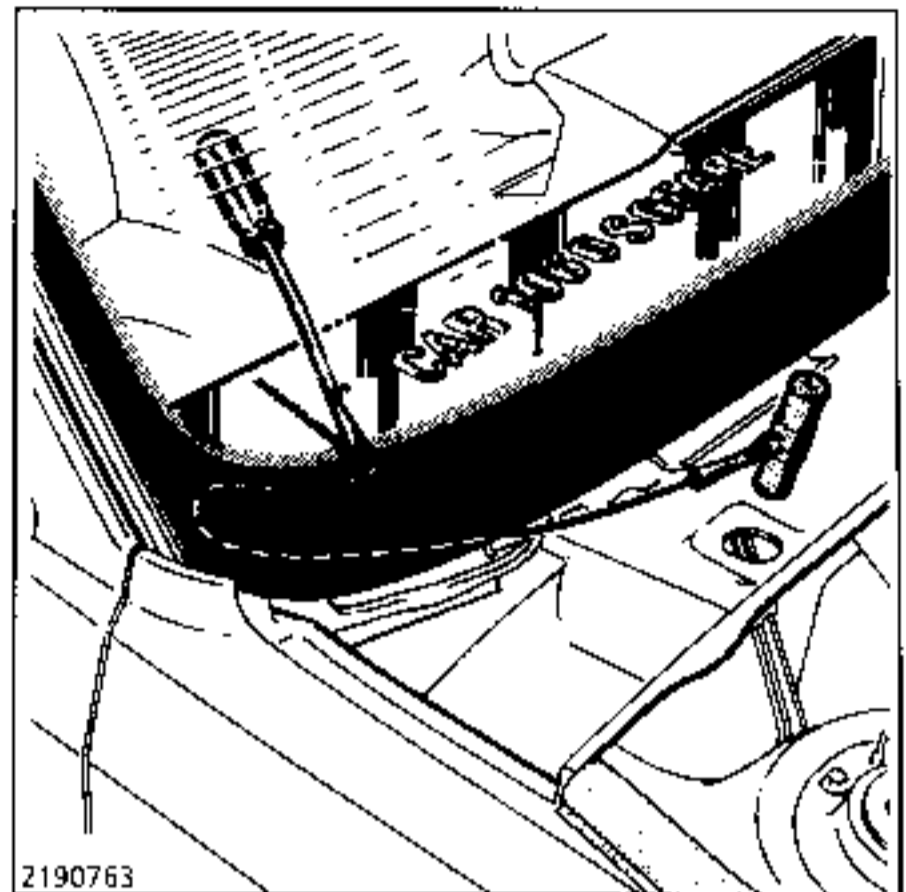

For the lower corners, pass the wire under the window and pull at the opposite corner so as not to damage the upper corner of the wing.

In the lower part of the windscreen the mastic bead is situated very high with respect to the outer edge of the glass.

During the cutting operation, the operator pulling on the pulling handle should keep his hand as low as possible in order to avoid scraping the edge of the glass.

CLEANING THE EDGE OF THE WINDSCREEN APERTURE

Use a spatula approximately 20-25 mm wide which has been sharpened, to cut and smooth down the remaining mastic bead so that there remains a thickness of approximately 0.5-1 mm on the windscreen surround.

NOTE : It is essential that a film of this mastic should be left on the windscreen surround to act as a key for the new bead.

Remove all mastic residue and dust from the windscreen surround by blowing it with an air gun.

NOTE : Only use dry air which is absolutely free from oil. As a general rule, no cleaning product or degreasing agent is to be used on this film of mastic.

PREPARING THE NEW WINDSCREEN

Carefully clean the enamelled surface around the entire periphery of the windscreen.

- 1) If possible, use de-mineralised water, wiping it off with a dry clean cloth.
- 2) Then, use a degreasing solvent, using the special cloth supplied in the kit.

Apply glass primer between the anti-overflow seal and the edge of the windscreen over the 3 upper edges and over a width of approximately 20 mm along the anti-overflow seal for the lower edge.

Fit the moulding to the upper edge of the windscreen.

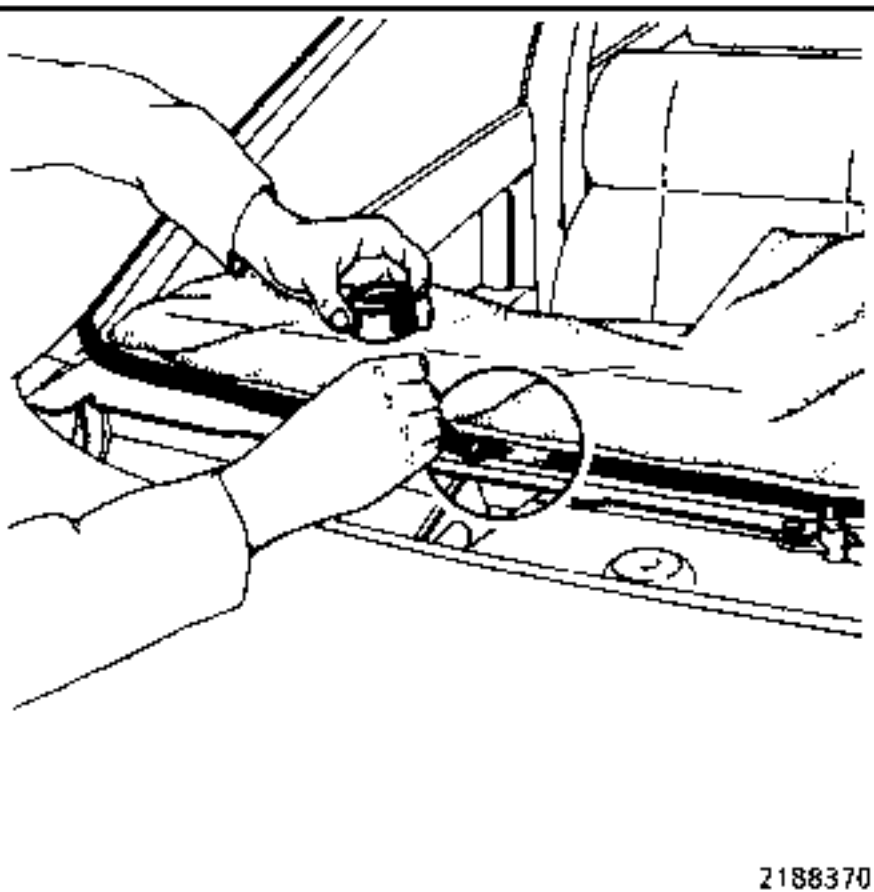
PREPARING THE WINDSCREEN SURROUND

Apply metal primer to those areas where the surround has been stripped back to the bare metal during removing or cleaning operations.

Do not apply it to the remaining strip of mastic. If necessary, re-cut the end of the applicator with a pair of scissors.

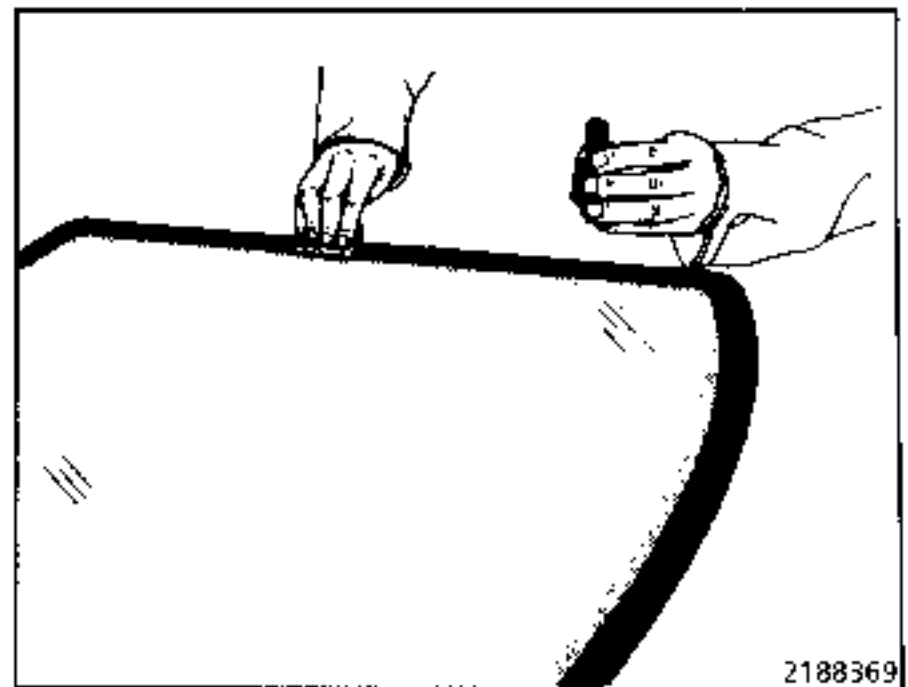
**REFITTING**

Refit the double seal.

For the Renault 21, a special nozzle which has already been cut out to a triangular shape has been added to the kit.

If you do not have this nozzle, cut the one found in your kit so as to obtain a triangle with a base approximately 7 mm long and height 10 mm.

Taking the cartridge, pierce the diaphragm with a screwdriver and screw on the nozzle.

Remove the base from the cartridge and take out the drying agent.

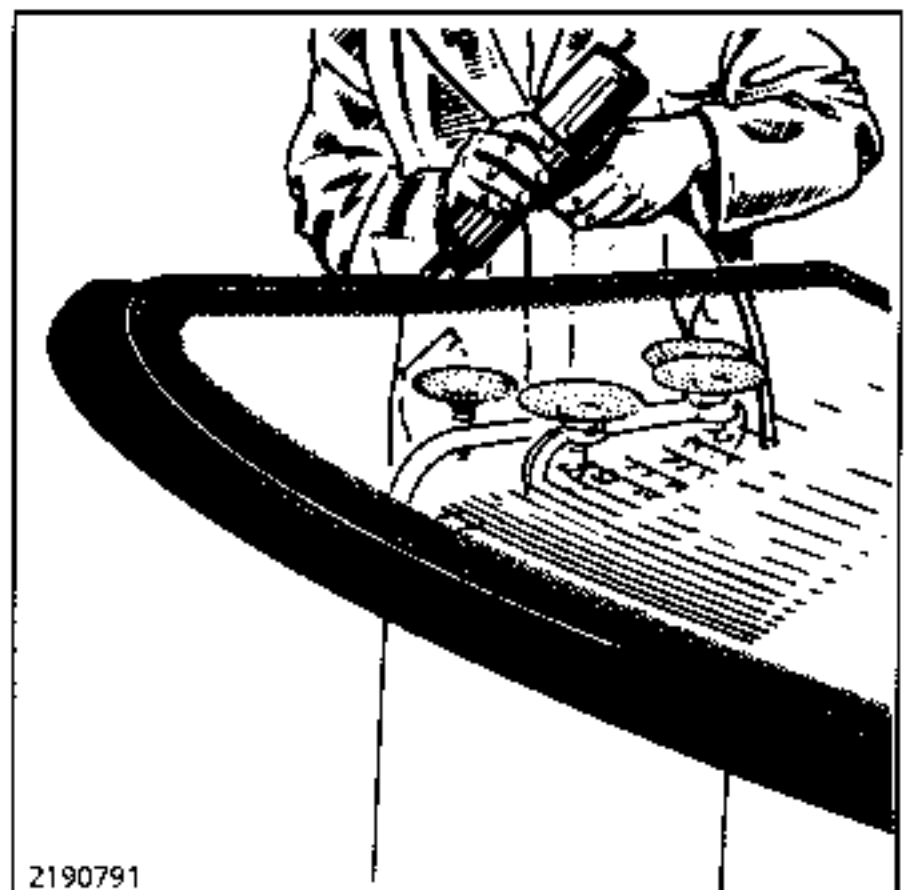

Using a spray gun, apply the mastic bead to the windscreen along the anti-overflow seal. Using a spatula, smooth down the join where the ends of the mastic bead meet.

Keep the cartridge as the remaining mastic can be used to bond the mouldings.

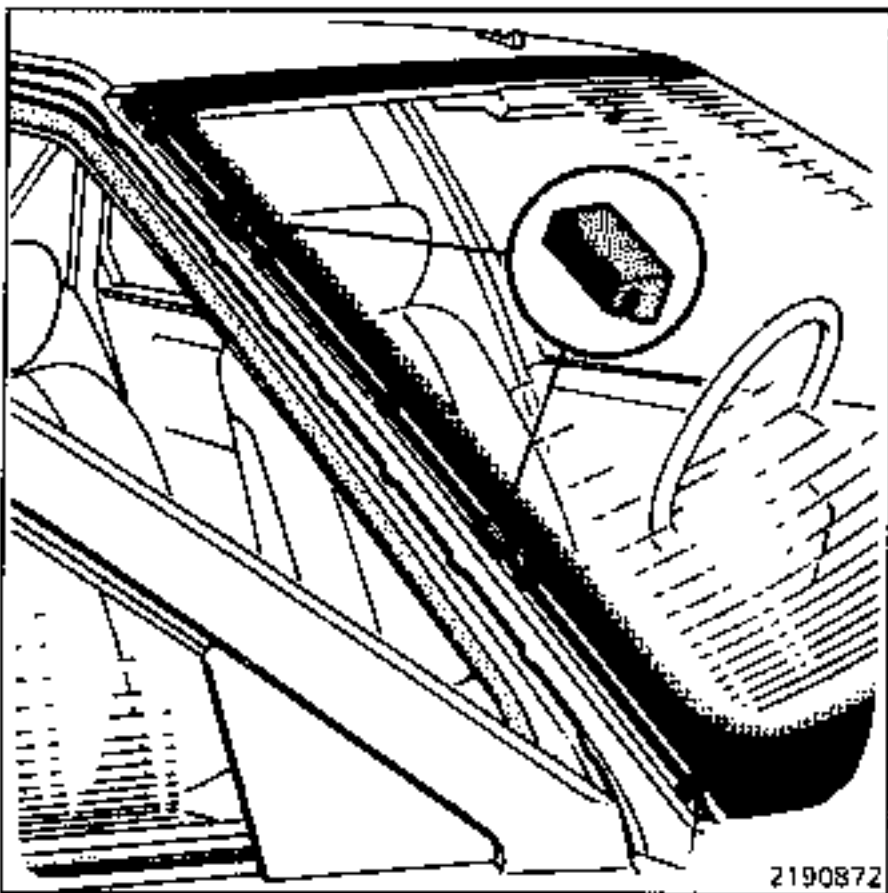

To make it easier to centre the windscreen at the sides, fit the Renault 25 locating wedges to be found in the bonding kit, to the windscreen aperture.

Using the suction pads, place the windscreen on the vehicle.

IMPORTANT : The windscreen must be offered up parallel to the aperture. Fit it, centring it between the wedges and so that it abuts the base of the upper aperture.

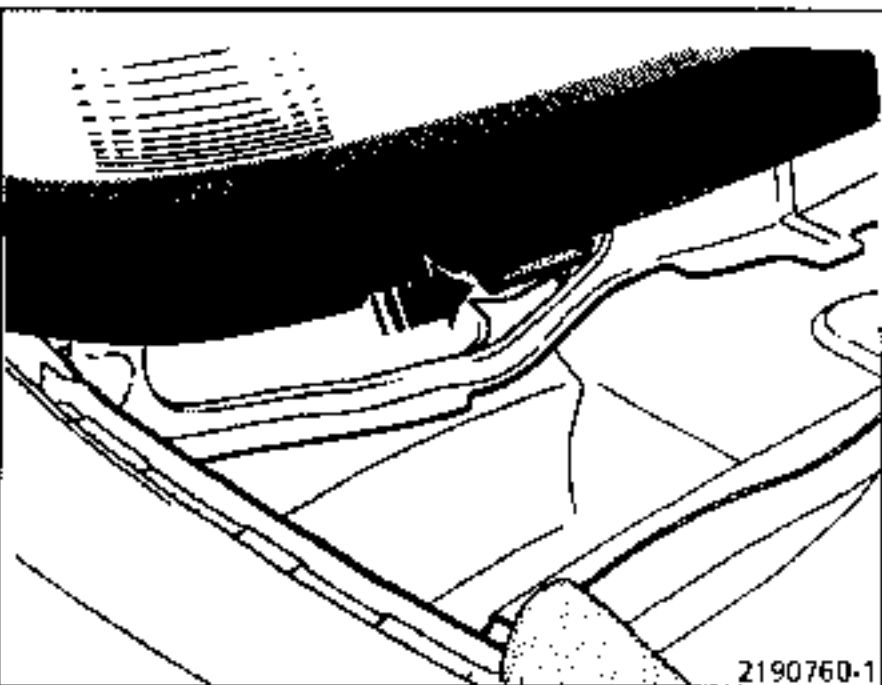

Check the clearance between the windscreen glass and the lower stop mounting lugs. It should be approximately 9 mm.

Fit the lower stops and clip them so that the windscreen is held correctly in the base of the aperture.

REFITTING THE MOULDINGS

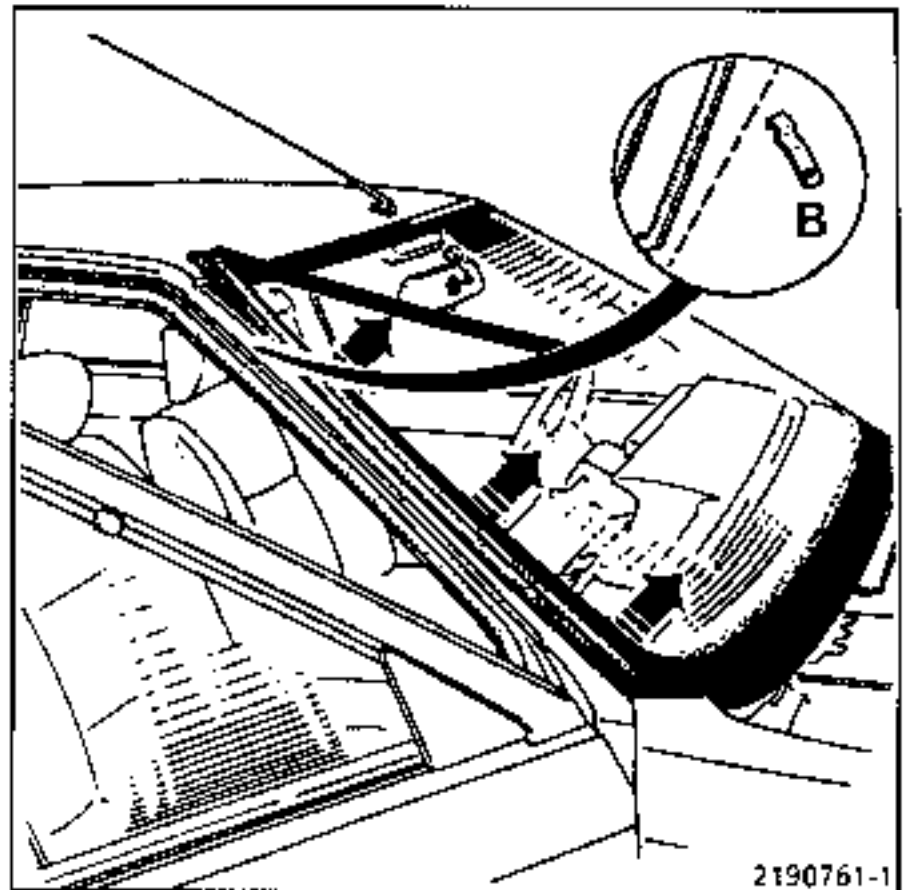

Use the remaining mastic to apply a thin bead to the area of the aperture or in the groove of the new moulding.

Fit the mouldings, starting by sliding the lower part of over the wing. Adjust the final position by guiding it in relation to the upper corner.

Clip the upper part of the mouldings in place and refit the centre clip.

Refit the scuttle grille and the windscreen wiper blades.

NOTE : The vehicle must remain stationary for at least 3 hours. You are strongly recommended to use this time to run water over the edge of the windscreen in order, on the one hand, to find any areas where the sealing is poor and, on the other hand, to accelerate polymerisation of the mastic thanks to the moisture.

REMOVING THE TRIM

Remove the internal trim from the rear quarter window.

Remove the double seal away from the rear door frame.

REMOVAL

Using a wide strip of adhesive tape, protect the bodywork around the edge of the window.

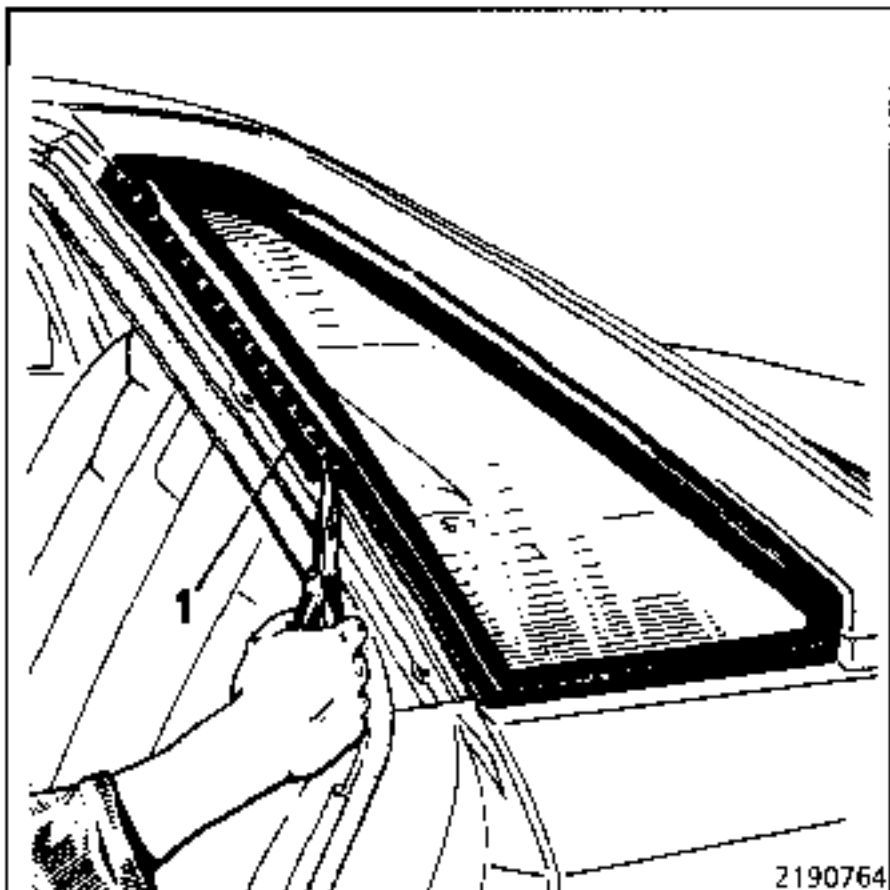

NOTE : Removal of the window means that the moulding frame must be replaced.

Using a pair of pliers, break the return (1) on the plastic moulding frame following the dotted line (----).

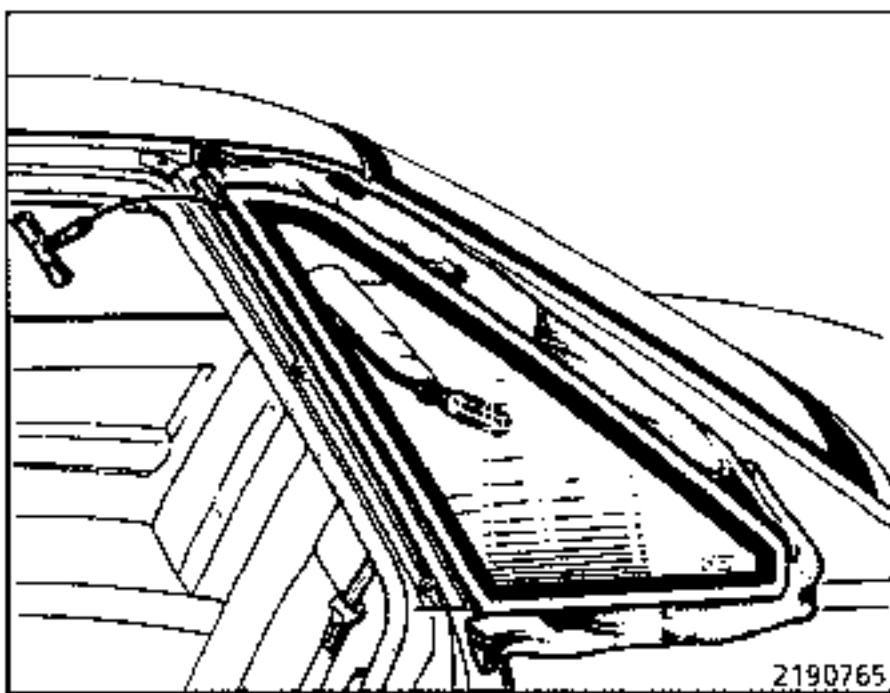

Pass a piece of steel wire approximately 30 cm long through the bead of mastic at the upper corner. Fit in place the pricker tool and pulling handle. Cut the mastic bead following the order shown in the drawing.

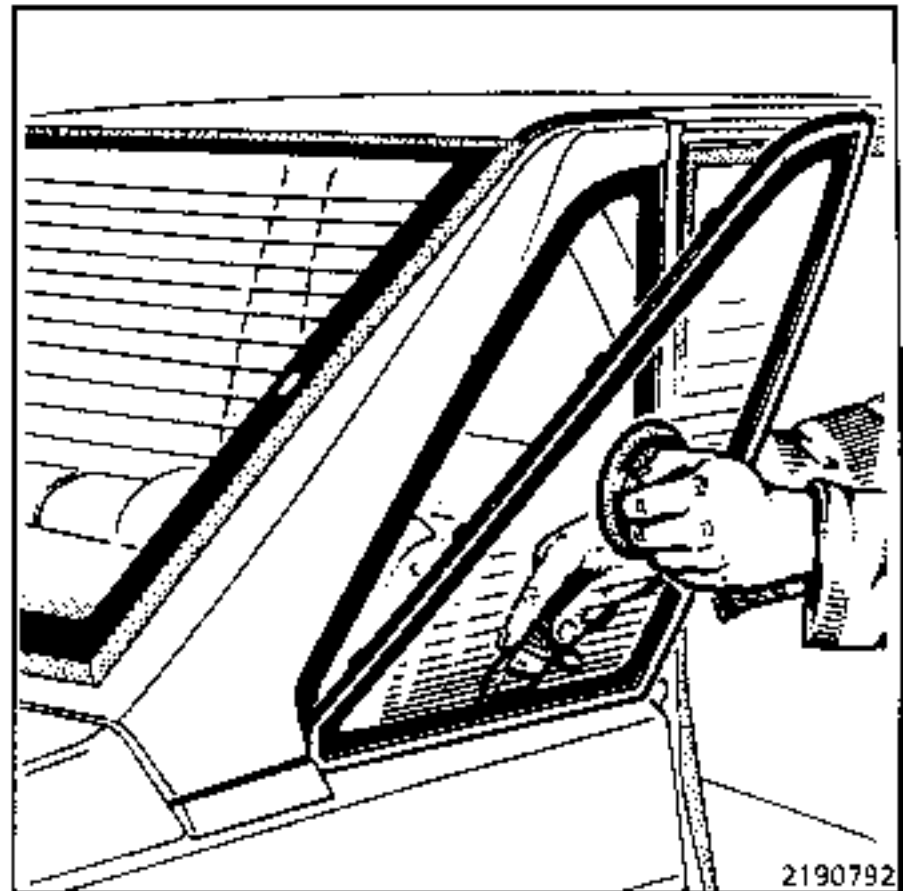

After cutting the first 2 sides, move the window away and, using a sharp blade, cut the remaining mastic taking care not to catch the 3 clips holding the frame.

CLEANING THE WINDOW SURROUND

Using a spatula approximately 20-25 cm wide, the edge of which has been sharpened, cut and smooth down the mastic bead to leave a thickness of approximately 0.5 to 1 mm of mastic on the surround.

NOTE : It is essential to leave a film of mastic on the window surround to act as a key for the new bead.

Remove all mastic residue and dust by blowing it with an air gun.

NOTE : Only use dry air, free from all traces of oil.

As a general rule, no cleaning or degreasing product is to be used on the remaining film of mastic.

PREPARING THE NEW WINDOW

Carefully clean the enamelled surface around the entire periphery of the windscreen.

- 1) If possible, use de-mineralised water, wiping it off with a dry clean cloth.
- 2) Then, use a degreasing solvent, using the special cloth supplied in the kit.

Using the pad, apply the glass primer to the enamelled surface.

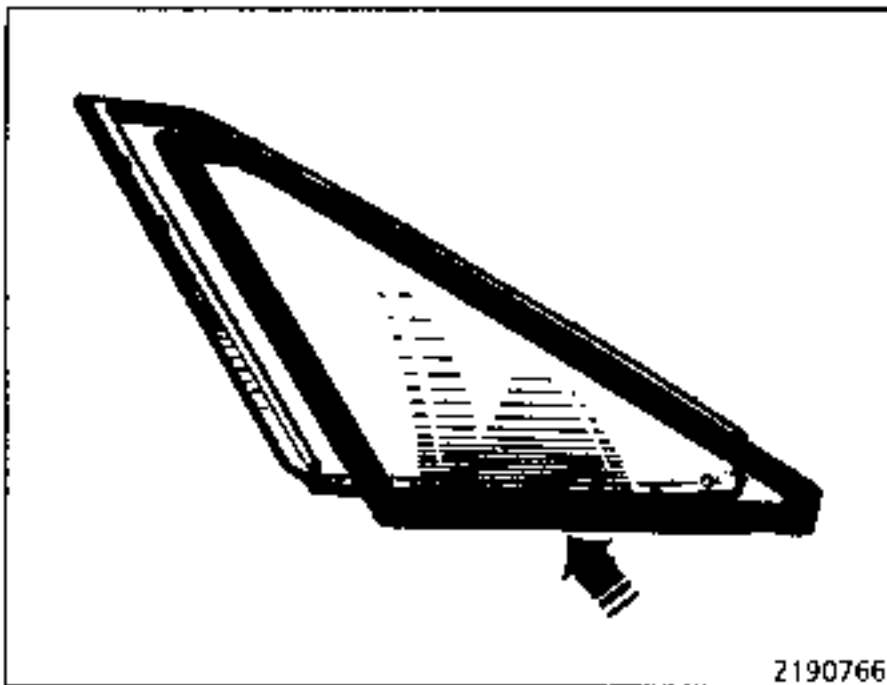

When the primer is dry, insert the window into the new moulding frame. Do not touch the prepared surface with your fingers.

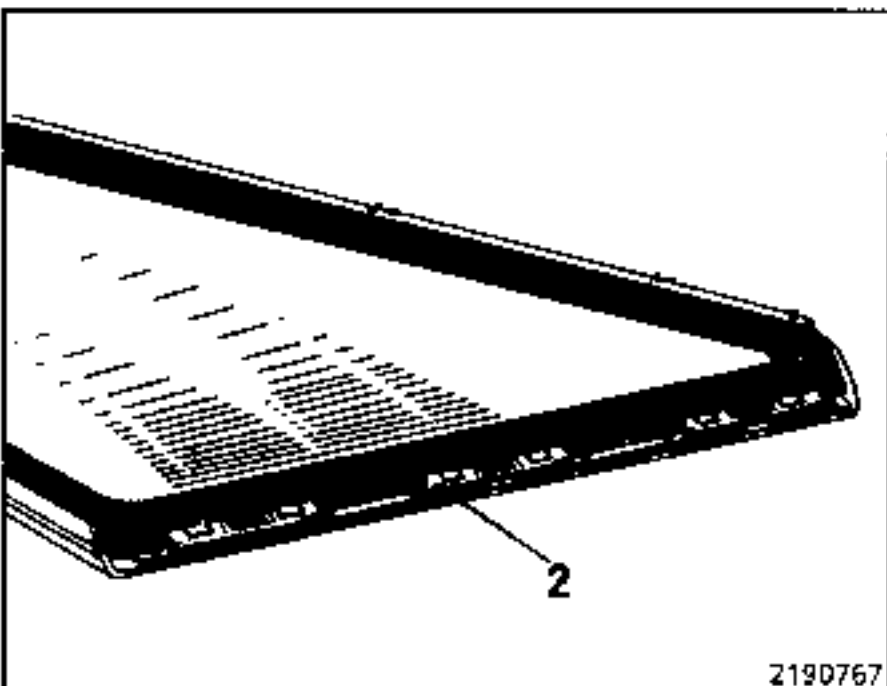

fit the clips (2) securing the moulding frame to the glass.

PREPARING THE WINDOW SURROUND

Apply a metal primer to those parts of the surround that have been damaged back to the bare metal during the removing or cleaning operations.

Do not apply this primer to the remaining film of mastic. If necessary, re-cut the applicator with a pair of scissors.

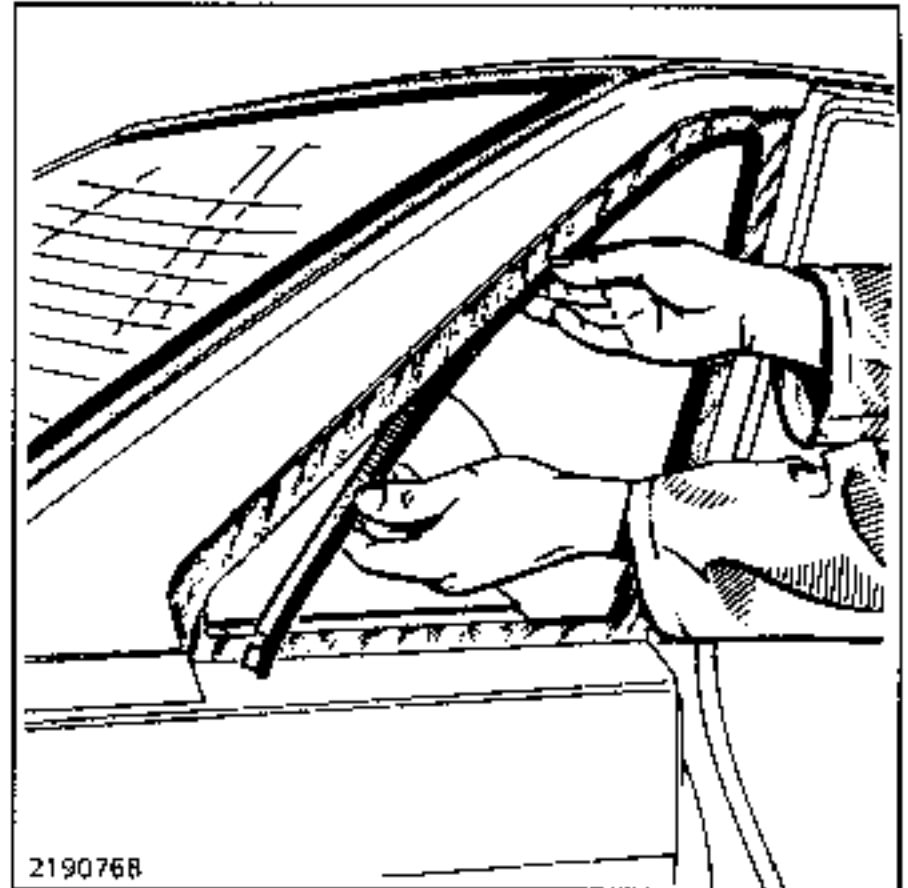

Fit the anti-overflow seal, bonding the adhesive surface inside the aperture.

REFITTING

Pierce the membrane on the mastic cartridge and screw on the nozzle pre-cut to a triangular shape.

NOTE : If you do not have this nozzle, cut the one found in your kit so as to obtain a triangle with a base approximately 7 mm long and height 10 mm.

Remove the bottom of the cartridge and take out the drying agent.

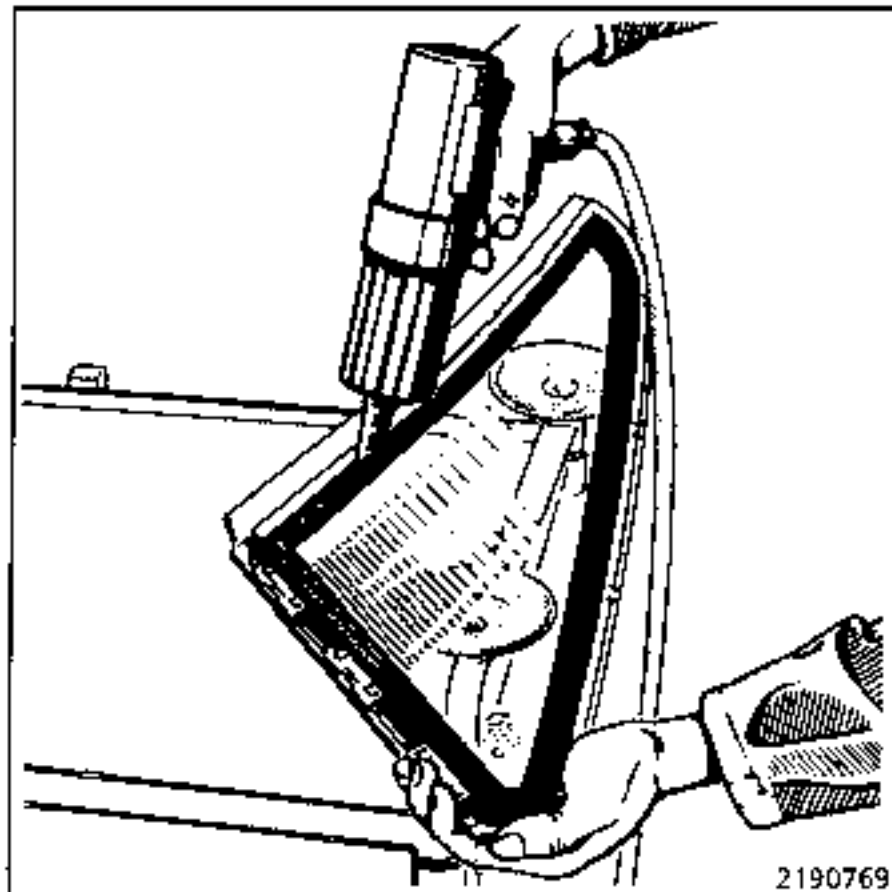

Using the spray gun, apply a bead of mastic to the window running along the edge of the clips and following the edge of the moulding frame. Use a spatula to smooth down the join where the ends of the mastic bead meet.

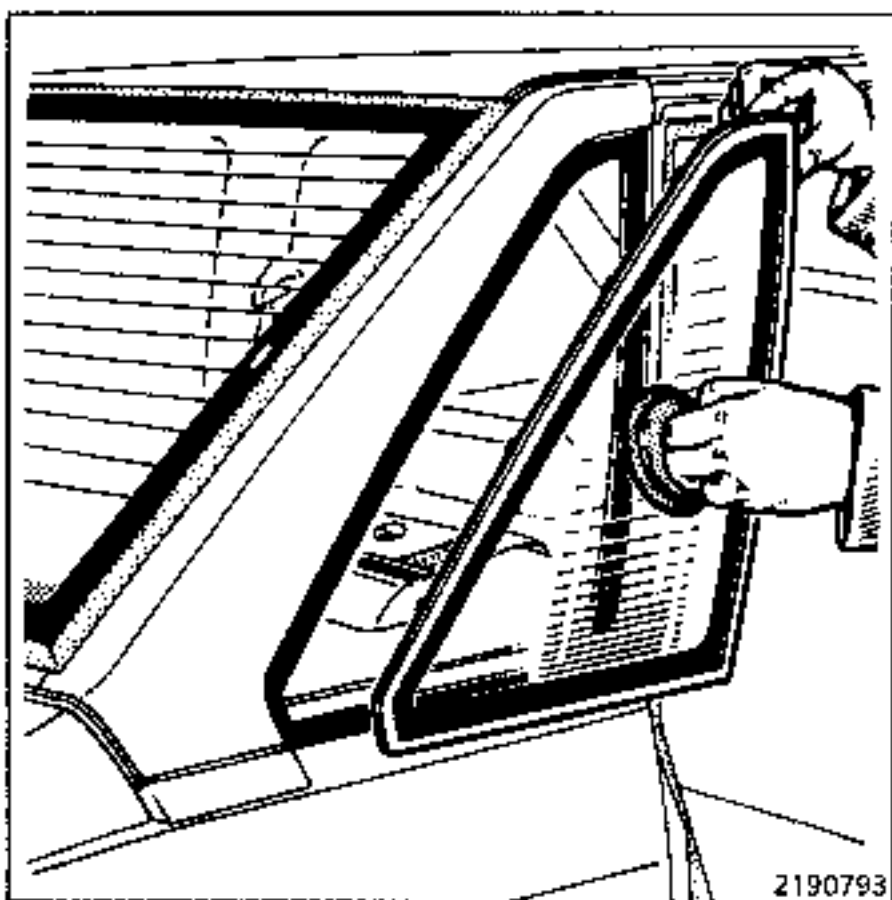

Using a single suction pad (for the part number see the beginning of the section), fit the window to the vehicle offering it up parallel to the aperture.

Adjust the position of the window in relation to the rear door when closed and hold it in place using a strip of adhesive tape.

Refit the double seal and the quarter panel internal trim.

NOTE : The speed of polymerisation of the bonding mastic is the same as for the windscreen or the rear screen. However, if the customer so wishes, the vehicle may be returned to him at the end of the operation. If this is the case, hold the window in position using a wide strip of strong adhesive tape stuck around the glass so as to prevent any risk of its lifting.

REMOVING THE TRIM

Remove the trim from inside the rear quarter panel.

REMOVAL

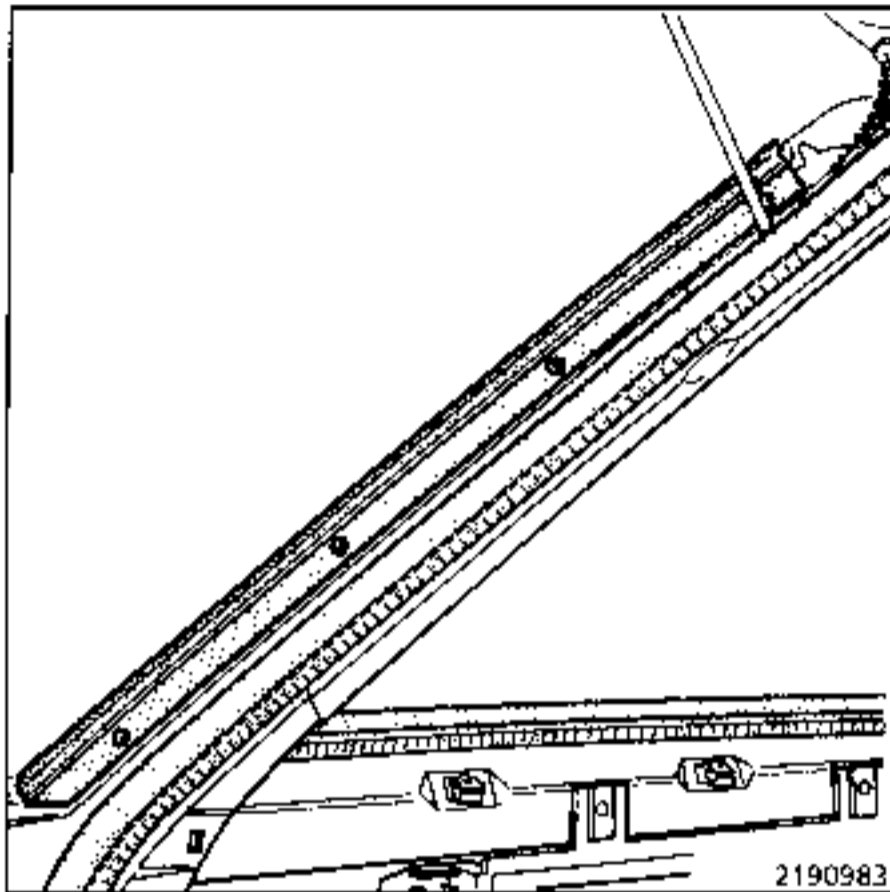

Remove the 4 rivets holding the rear moulding.

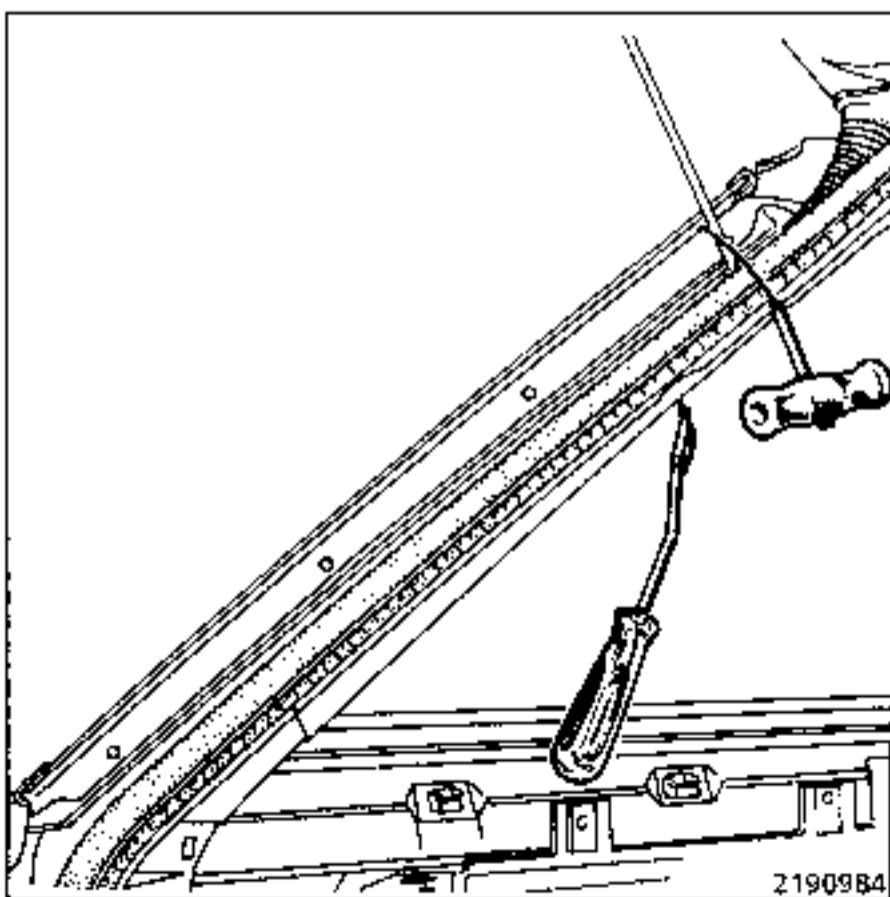

Using a wide strip of adhesive tape, protect the bodywork around the edge of the window.

Pass a piece of steel wire approximately 30 cm long through the mastic bead at the upper rear corner. Fit in place the pricker tool and pulling handle.

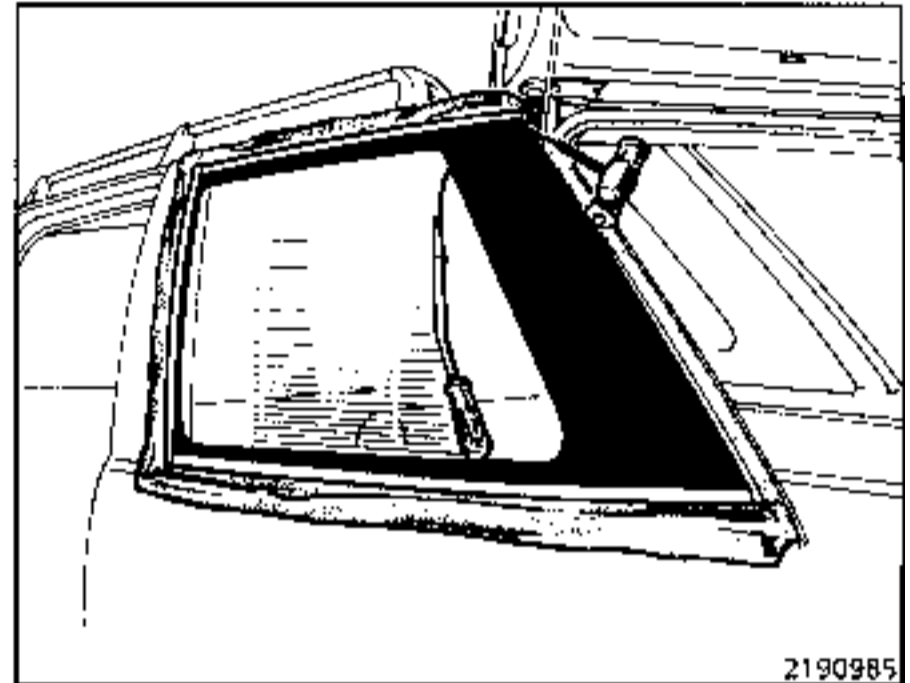

Cut the mastic bead as shown in the drawing above.

NOTE : The 3 mouldings (upper, lower and front) stay fitted on the window when it is removed. Keep a constant watch on the cutting wire.

When the window has been removed, check the condition of the mouldings.

CLEANING THE WINDOW SURROUND

Using a spatula approximately 20-25 cm wide, the edge of which has been sharpened, cut and smooth down the mastic bead to leave a thickness of approximately 0.5 to 1 mm of mastic on the surround.

NOTE : It is essential to leave a film of mastic on the window surround to act as a key for the new bead.

Remove all mastic residue and dust by blowing it with an air gun.

NOTE : Only use dry air, free from all traces of oil.

As a general rule, no cleaning or degreasing product is to be used on the remaining film of mastic.

PREPARING THE WINDOW SURROUND

Apply a metal primer to those parts of the surround that have been damaged back to the bare metal during the removing or cleaning operations.

Do not apply this primer to the remaining film of mastic. If necessary, re-cut the applicator with a pair of scissors.

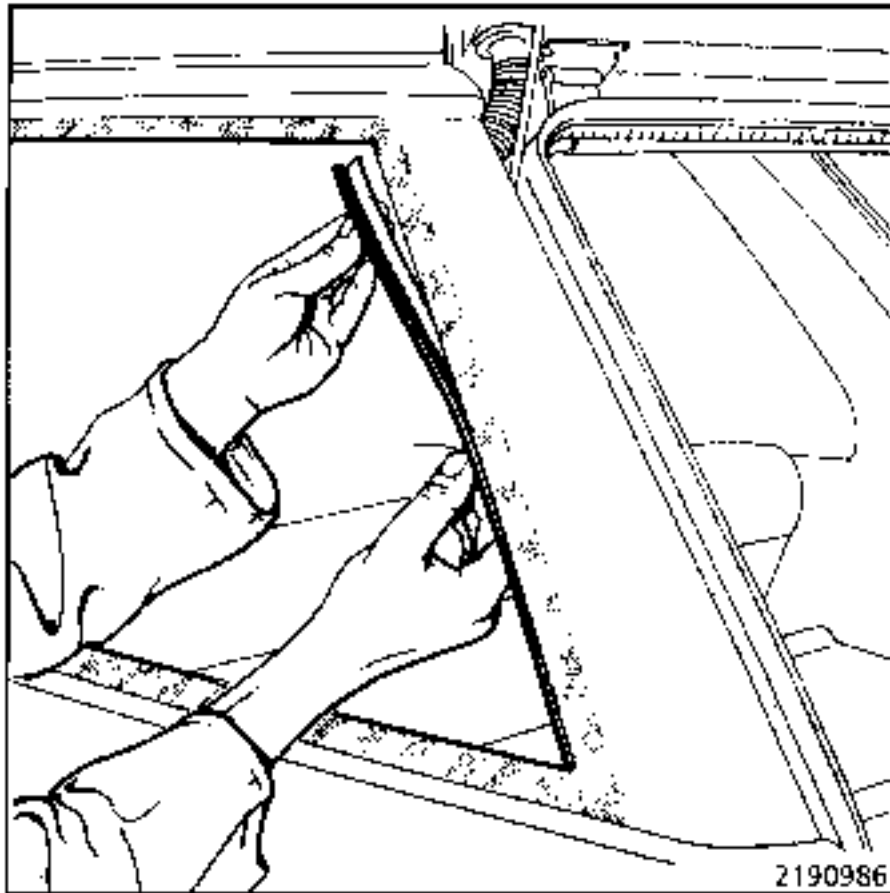

Fit the anti-overflow seals (1 per side), sticking the adhesive surface inside the aperture.

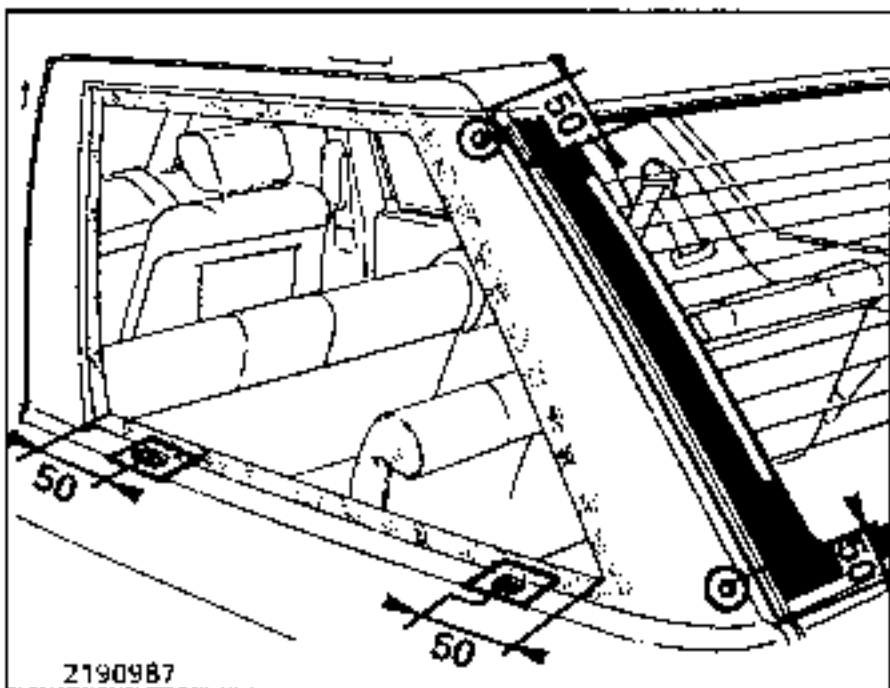

Fit the wedges for the base of the aperture and the round bearing stops as shown in the drawing above.

PREPARING THE NEW WINDOW

Carefully clean the enamelled surface around the entire periphery of the windscreen.

- 1) If possible, use de-mineralised water, wiping it off with a dry clean cloth.
- 2) Then, use a degreasing solvent, using the special cloth supplied in the kit.

Using the pad, apply the glass primer to the enamelled surface approximately 5 mm from the edge of the enamelled surface on the inner edge and over a width of 20 mm.

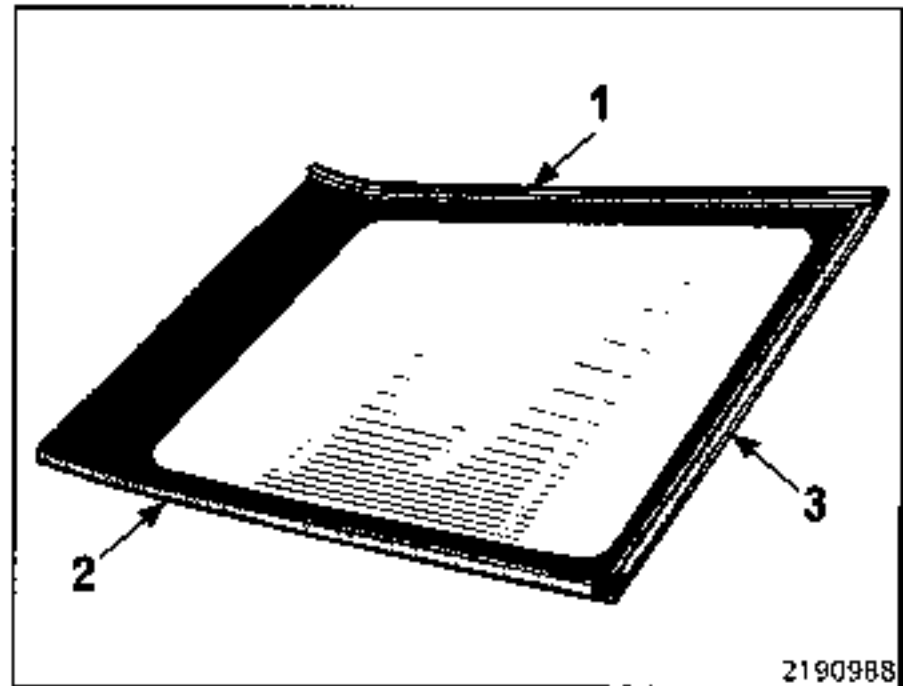

Fit the upper and lower trim pieces (1) and (2) to the edge of the window pushing them down to approximately half the depth of the U shape. Then fit the front moulding (3) in the same way.

Offer up the screen to the vehicle.

Rectify the positions of the mouldings to obtain a clearance of approximately 2 mm between them and the window surround.

REFITTING

Pierce the membrane on the mastic cartridge and screw on the nozzle pre-cut to a triangular shape.

NOTE : If you do not have this nozzle, cut the one found in your kit so as to obtain a triangle with a base approximately 7 mm long and height 10 mm.

Pierce the base of the cartridge.

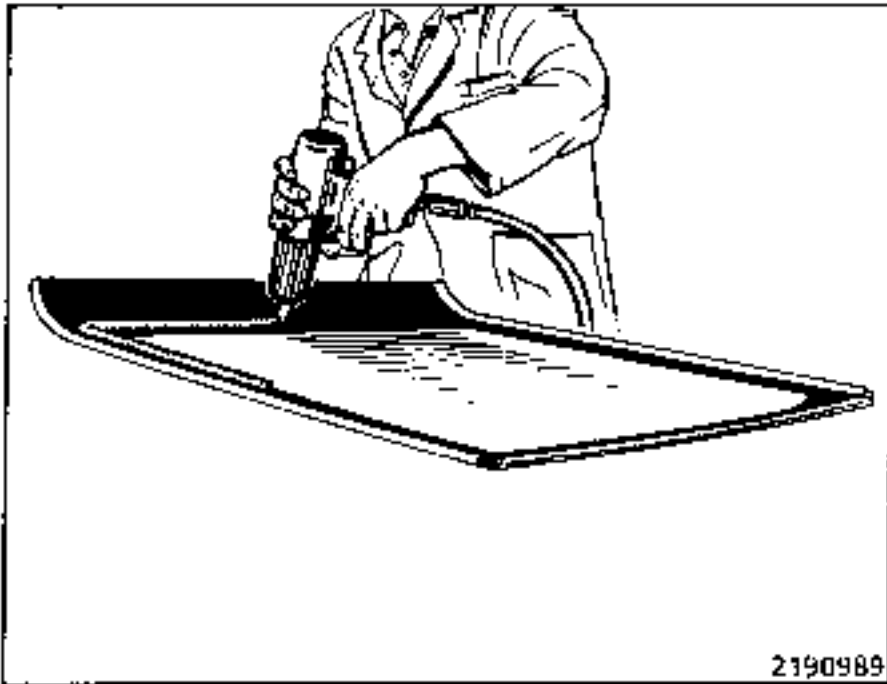

Using a spray gun, apply a bead of mastic over the primer strip, using the mouldings as a guide.

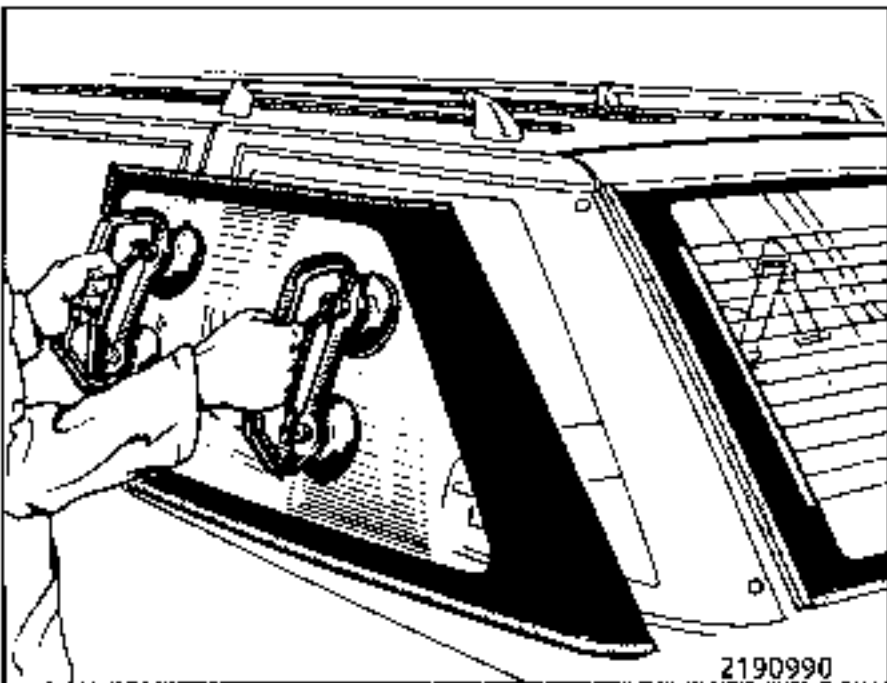

Using the suction pads, fit the window to the vehicle offering it up parallel to the aperture.

Alter the position of the window in relation to the aperture and the rear screen. Hold the window in place using a wide strip of adhesive tape.

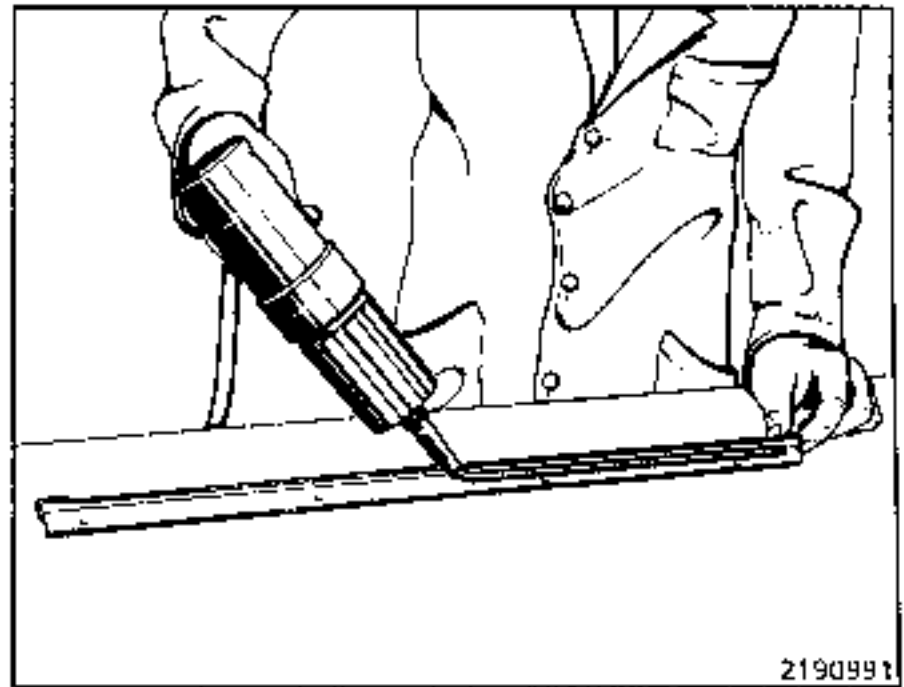

If the moulding has to be replaced, prepare it by applying a small bead from the mastic remaining in the cartridge.

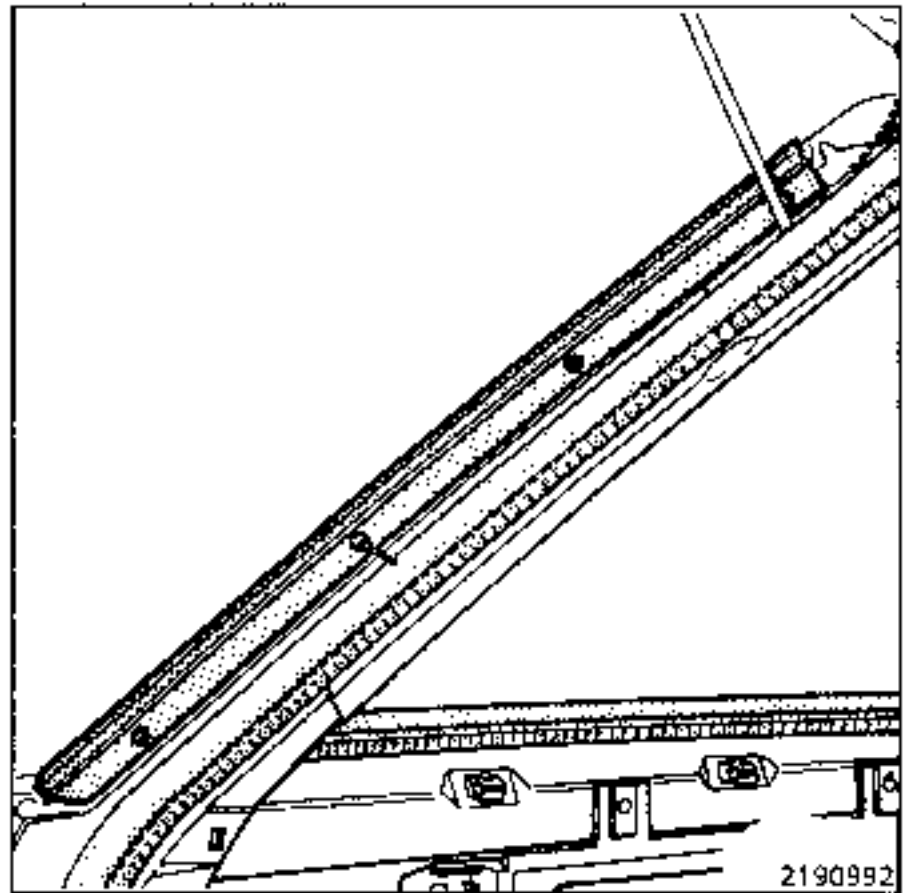

Fit the moulding and align it with the 2 upper and lower mouldings and the rear screen.

Secure it using leaktight rivets, Part No :77 03 072 051.

Check that the window is held in place correctly with the adhesive tape. If necessary, use a strap to ensure that it is held.

NOTE : The vehicle must remain stationary for at least 3 hours. You are strongly recommended to use this time to run water over the edge of the windscreen in order, on the one hand, to find any areas where the sealing is poor and, on the other hand, to accelerate polymerisation of the mastic which is of the moisture-cured type.

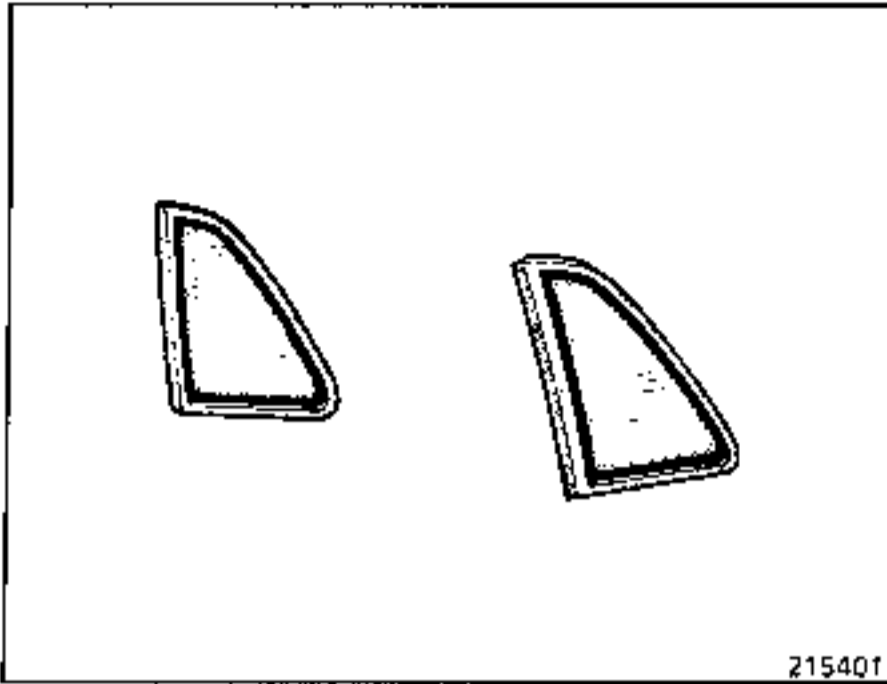

This window is of the moulded type, that is, the moulding is moulded around its edge. It is impossible to separate the moulding from the window.

REMOVAL

Two methods may be used to cut the bonding mastic bead. In each case proceed with care so as not to damage the moulding.

Method 1

Remove the trim from the rear quarter window.

Partially remove the double seal.

Using a strip of wide adhesive tape, protect the bodywork around the window.

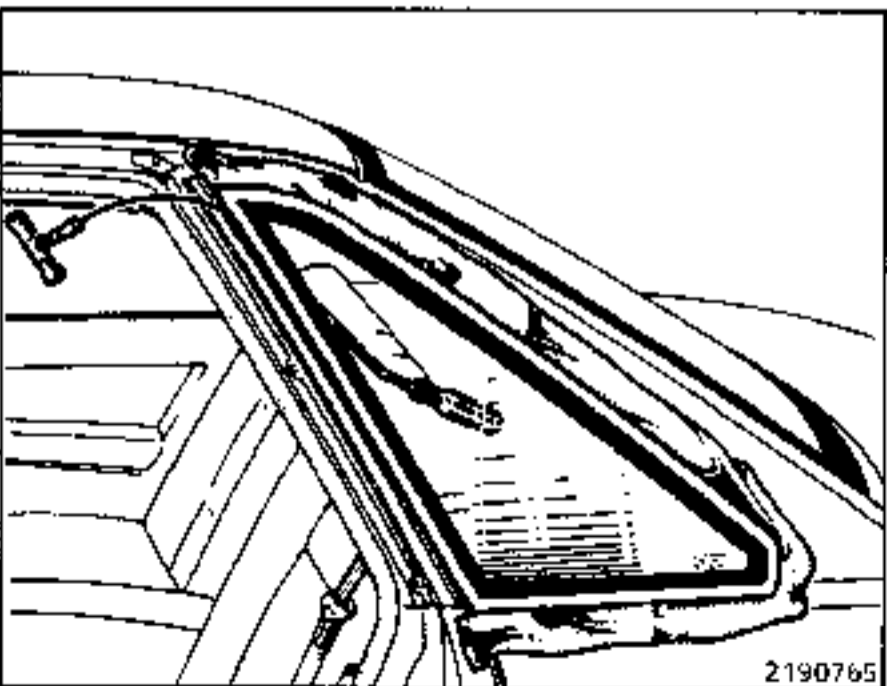

Pass a piece of steel wire approximately 30 cm long through the mastic bead at the upper corner. Fit in place the pricker tool and pulling handle. cut the mastic bead following the direction shown in the drawing.

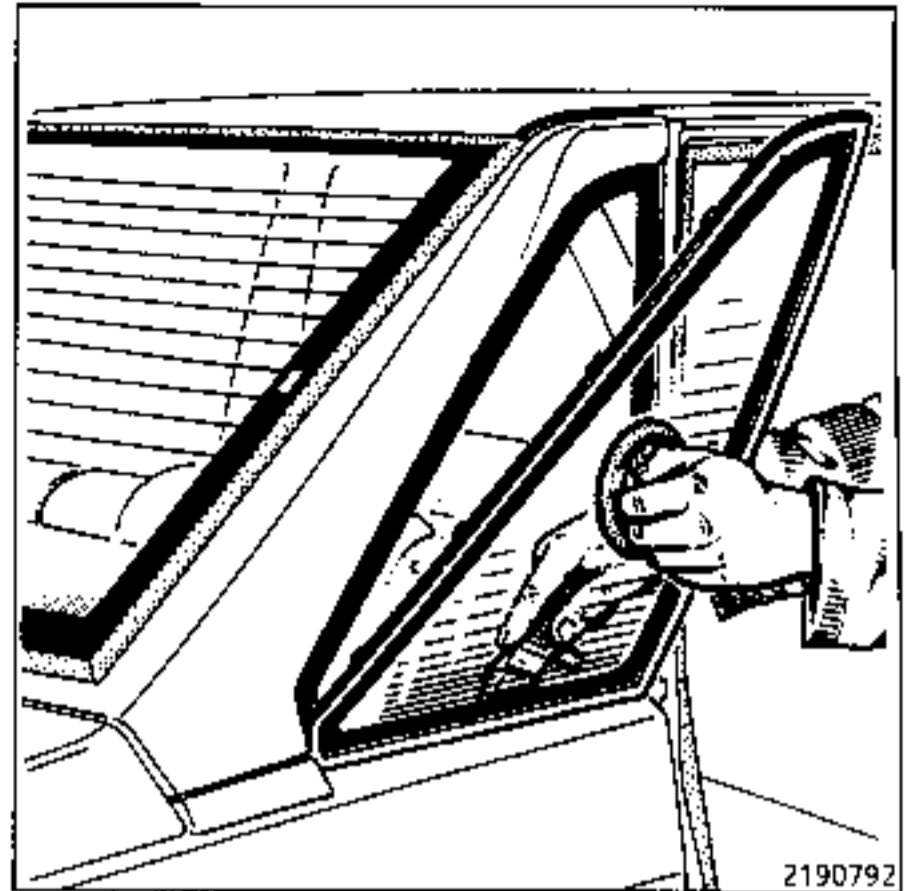

After the first two sides have been cut, move the window away and cut the remaining mastic using a cutting blade.

Method 2

The window may be removed using a FEIN electric blade. In this cases use blade, Part No : 63903097018.



2193650

Sharpen the blade using the machine on setting position 2.

Remove the trim from the rear quarter panel. Cutting is carried out from inside the vehicle. Start cutting by inserting the blade in the bead of glue (machine running on setting position 2).

Cut the mastic, varying the power of the machine to suit the stress applied for cutting.

NOTE : It is most important that the blade is sharp. The blade should be sharpened each time it is used.

REFITTING**CLEANING THE WINDOW SURROUND**

Using a spatula approximately 20-25 cm wide, the edge of which has been sharpened, cut and smooth down the mastic bead to leave a thickness of approximately 0.5 to 1 mm of mastic on the surround.

NOTE : It is essential to leave a film of mastic on the window surround to act as a key for the new bead.

Remove all mastic residue and dust by blowing it with an air gun.

NOTE : Only use dry air, free from all traces of oil.

As a general rule, no cleaning or degreasing product is to be used on the remaining film of mastic.

PREPARING THE NEW WINDOW

Carefully clean the enamelled surface around the entire periphery of the windscreen.

- 1) If possible, use de-mineralised water, wiping it off with a dry clean cloth.
- 2) Then, use a degreasing solvent, using the special cloth supplied in the kit.

Using the pad, apply the glass primer to the enamelled surface.

PREPARING THE WINDOW SURROUND

Apply metal primer to those parts of the surround that have been damaged back to the bare metal during the removing or cleaning operations.

FITTING THE WINDOW

Apply a bead of bonding mastic with a triangular cross-section to the window.

Guide the cartridge nozzle over the edge of the moulding.

Smooth down the join where the ends of the bead meet.

Using a suction pad, fit the window in place in its location.

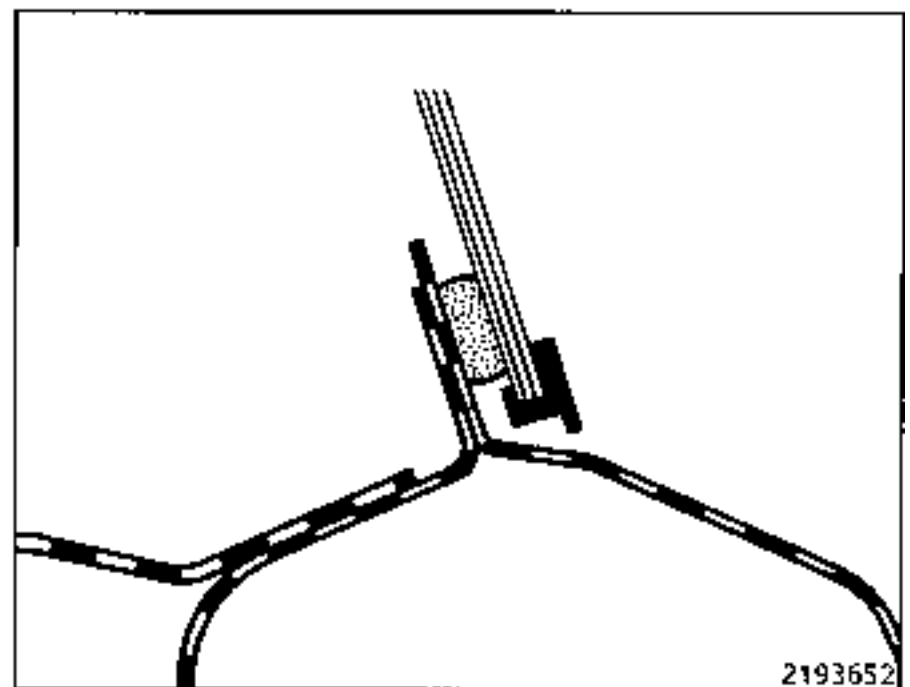

2193652

Centre the window so that a clearance of 2 mm is obtained between the edge of the moulding and the side panel.

NOTE : The vehicle must remain stationary for at least 3 hours. You are strongly recommended to use this time to run water over the edge of the windscreen in order, on the one hand, to find any areas where the sealing is poor and, on the other hand, to accelerate polymerisation of the mastic which is of the moisture-cured type.

STRIPPING

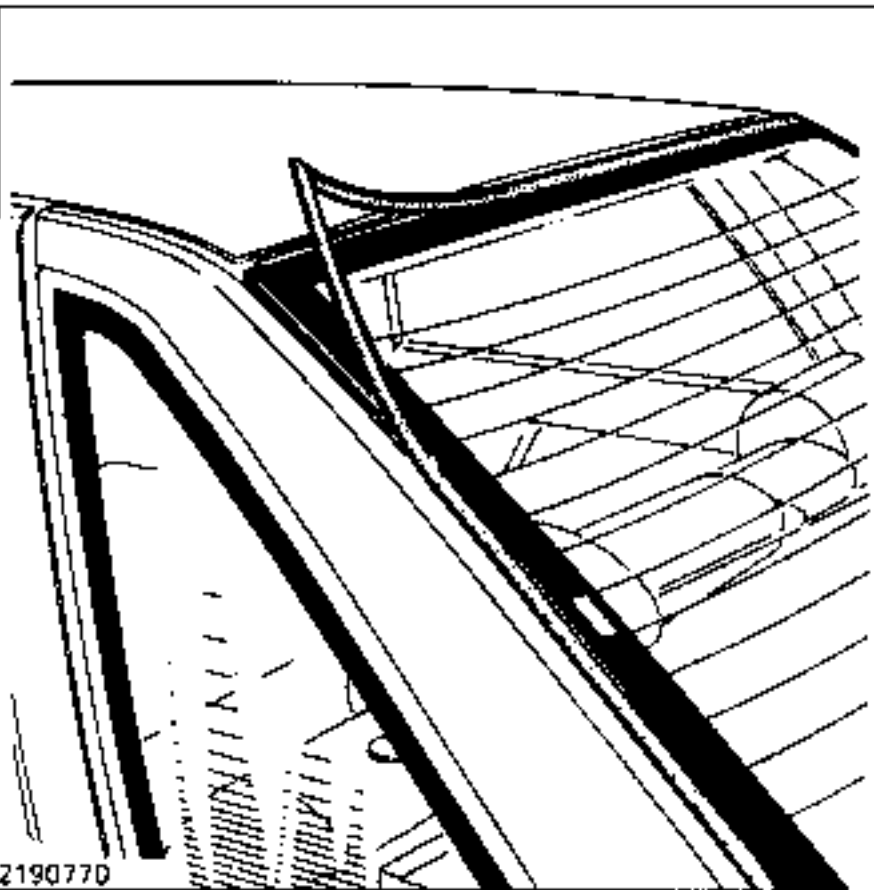

Remove :

- the outer moulding (in one part),
- the inner trim from the right-hand and left-hand rear quarter windows, to reach the connectors for the heated screen. Disconnect the connectors and fold back the tabs on the screen.

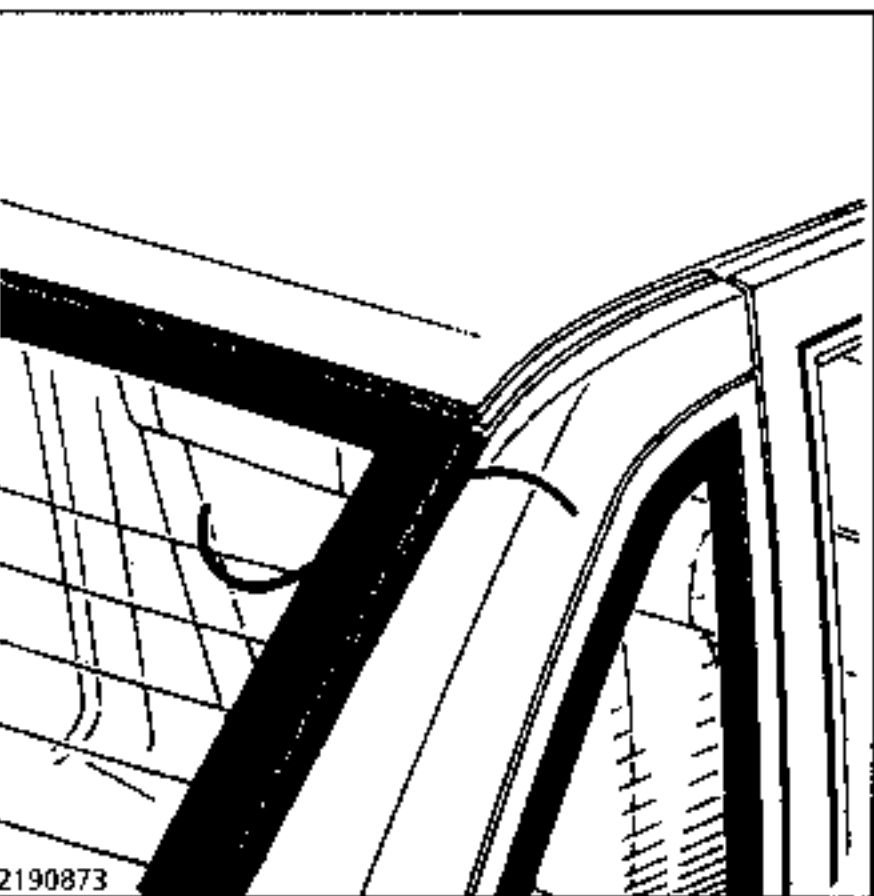

From outside the vehicle, check to see whether it is possible to pass the wire freely under the moulding mountings in all four corners of the screen when the seal is being cut. If it is not, remove the mounting or mountings which are in the way, after first protecting the frame with tape.

NOTE : It is easier to remove the mountings by heating them gently with a hot air torch.

In one corner, pass a piece of steel wire through the mastic bead. Fit in place the pricker tool and pulling handle. Cut the mastic bead taking care in the corners that the wire passes under the moulding mountings.

CLEANING THE WINDOW SURROUND

Using a spatula approximately 20-25 cm wide, the edge of which has been sharpened, cut and smooth down the mastic bead to leave a thickness of approximately 0.5 to 1 mm of mastic on the surround.

NOTE : It is essential to leave a film of mastic on the window surround to act as a key for the new bead.

Remove all mastic residue and dust by blowing it with an air gun.

NOTE : Only use dry air, free from all traces of oil.

As a general rule, no cleaning or degreasing product is to be used on the remaining film of mastic.

PREPARING THE NEW WINDOW

Carefully clean the enamelled surface around the entire periphery of the windscreen.

- 1) If possible, use de-mineralised water, wiping it off with a dry clean cloth.

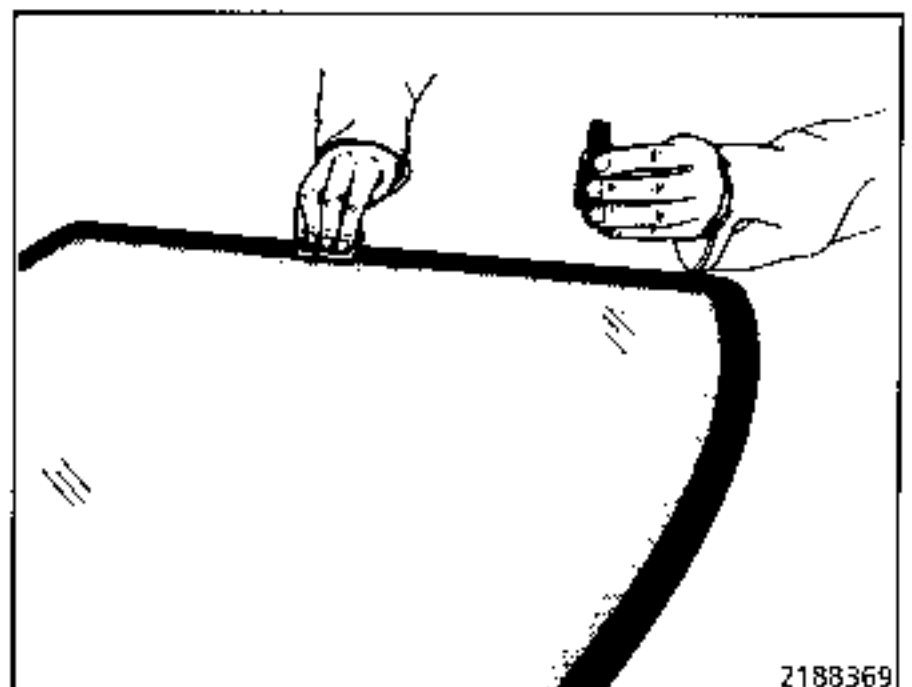

- 2) Then, use a degreasing solvent, using the special cloth supplied in the kit.

Do not touch the enamelled surface with your fingers.

Apply glass primer between the seal and the edge of the screen. Using a rubber mallet, fit on the 4 moulding mountings, after the primer has dried.

Fit in place the outer moulding.

Apply a metal primer to those parts of the surround that have been damaged back to the bare metal during the removing or cleaning operations.

Do not apply this primer to the remaining film of mastic. If necessary, re-cut the applicator with a pair of scissors.

REFITTING

Pierce the membrane on the mastic cartridge and screw on the nozzle pre-cut to a triangular shape.

Remove the bottom of the cartridge and take out the drying agent.

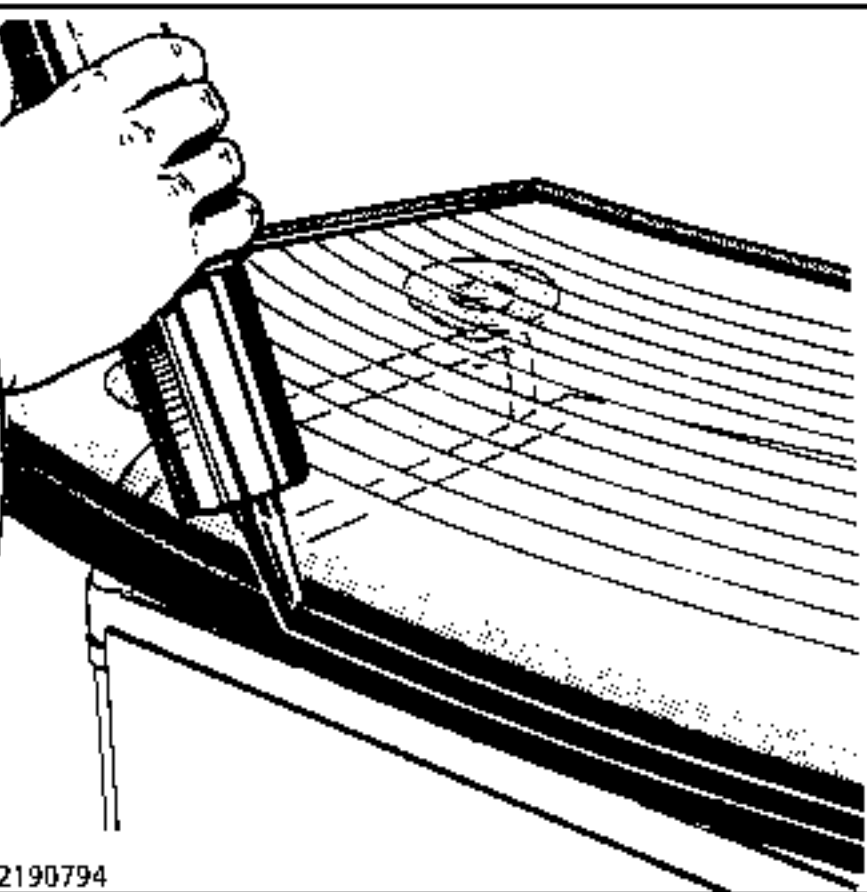

Using a spray gun apply a bead of mastic to the screen passing along the anti-overflow seal. Use a spatula to smooth down the join where the ends of the mastic bead meet.

Using the suction pads, fit the screen in place.

Reconnect the tabs for the heated screen and refit the rear quarter panel internal trim.

NOTE : The vehicle must remain stationary for at least 3 hours. You are strongly recommended to use this time to run water over the edge of the windscreen in order, on the one hand, to find any areas where the sealing is poor and, on the other hand, to accelerate polymerisation of the mastic which is of the moisture-cured type.

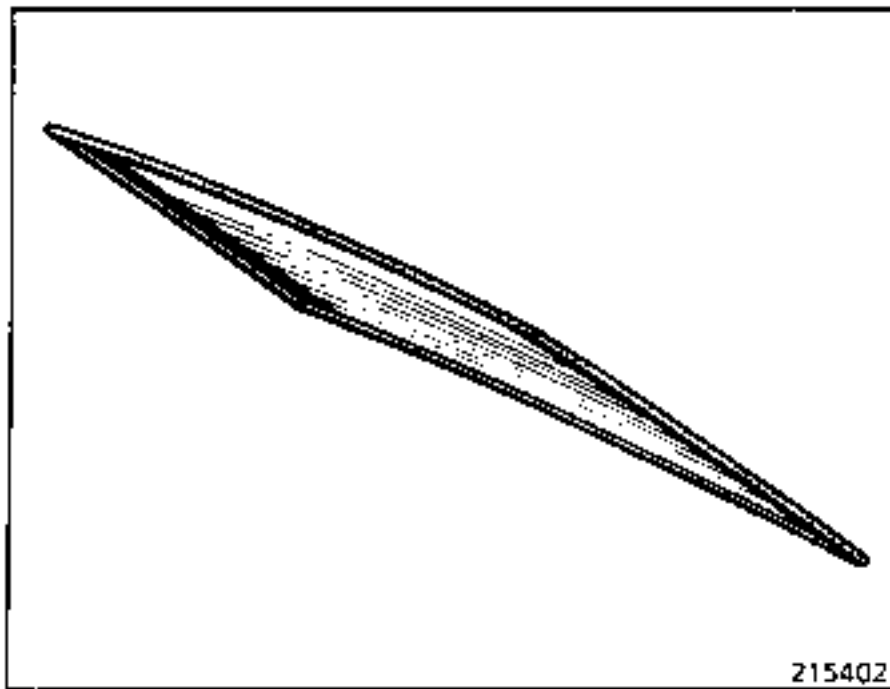

This window is of the moulded type, that is, the moulding is moulded around its edge. It is impossible to separate the moulding from the window.

REMOVAL

Two methods may be used to cut the bonding mastic bead. In each case proceed with care so as not to damage the moulding.

Method 1

Disconnect the feed wires from the heated screen.

Remove the anti-overflow seal.

The seal may have to be pulled relatively hard to remove it from the screen surround if this is set in the bonding mastic.

Stick a strip of adhesive tape to the upper and lower edges of the tailgate.

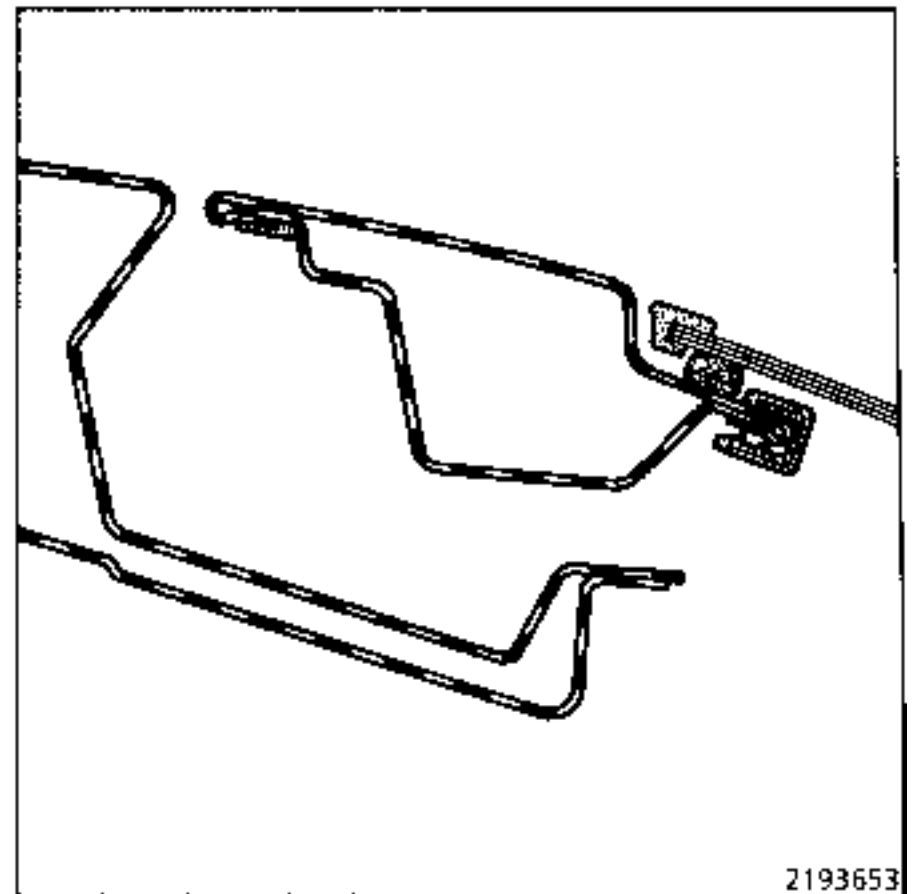

At the edges (lower and upper) check to see whether the clearance between the moulding and the surround is sufficient to pass through the cutting wire. If it is not, use Method 2.

Pass a piece of cutting wire through the mastic bead, in one of the 2 upper corners.

Cut the mastic bead finishing at the opposite lower corner.

Method 2

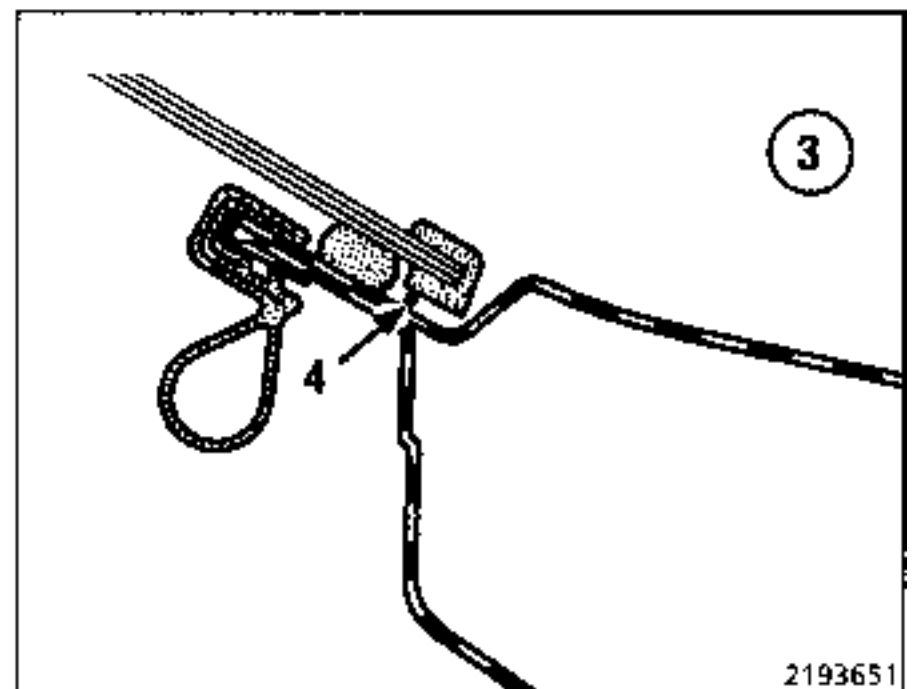
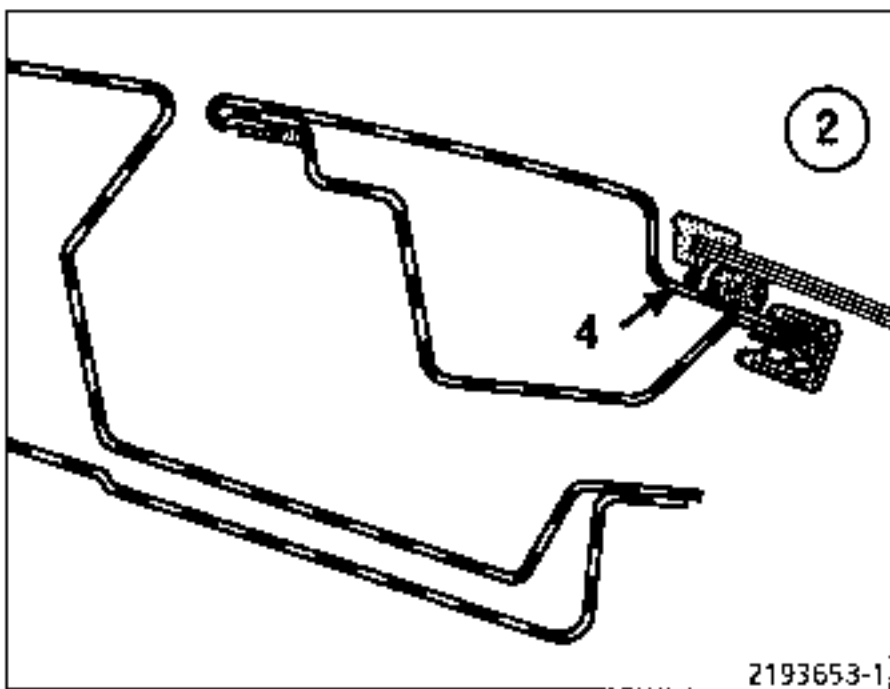
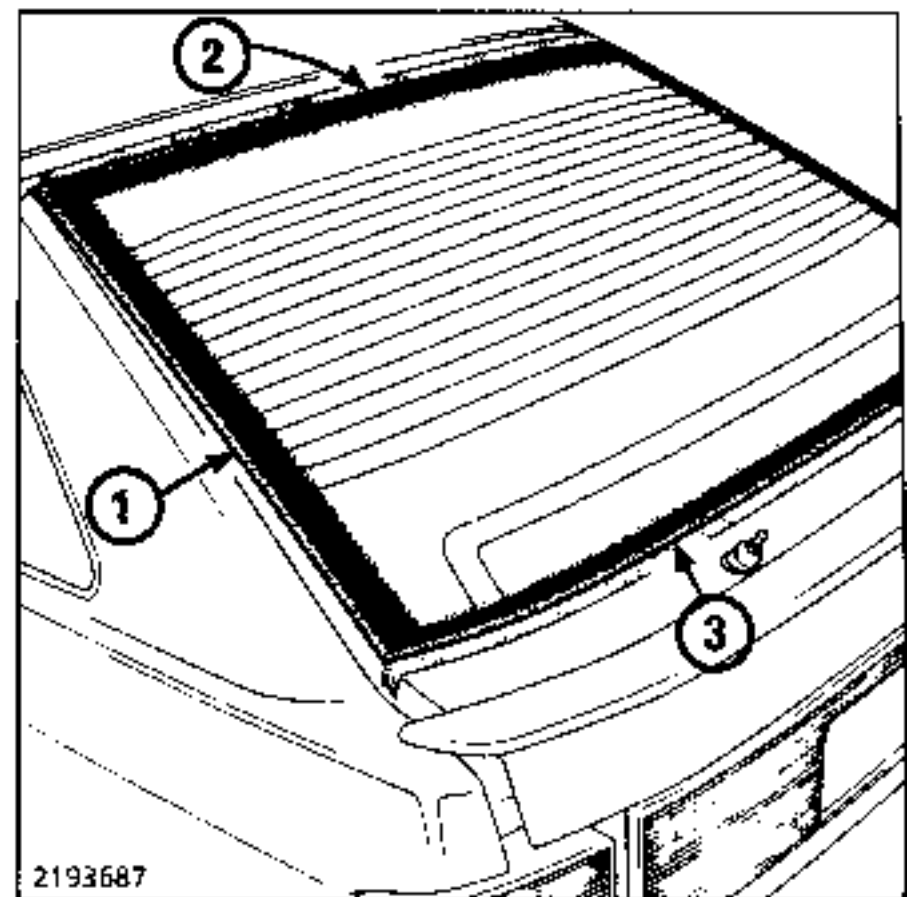
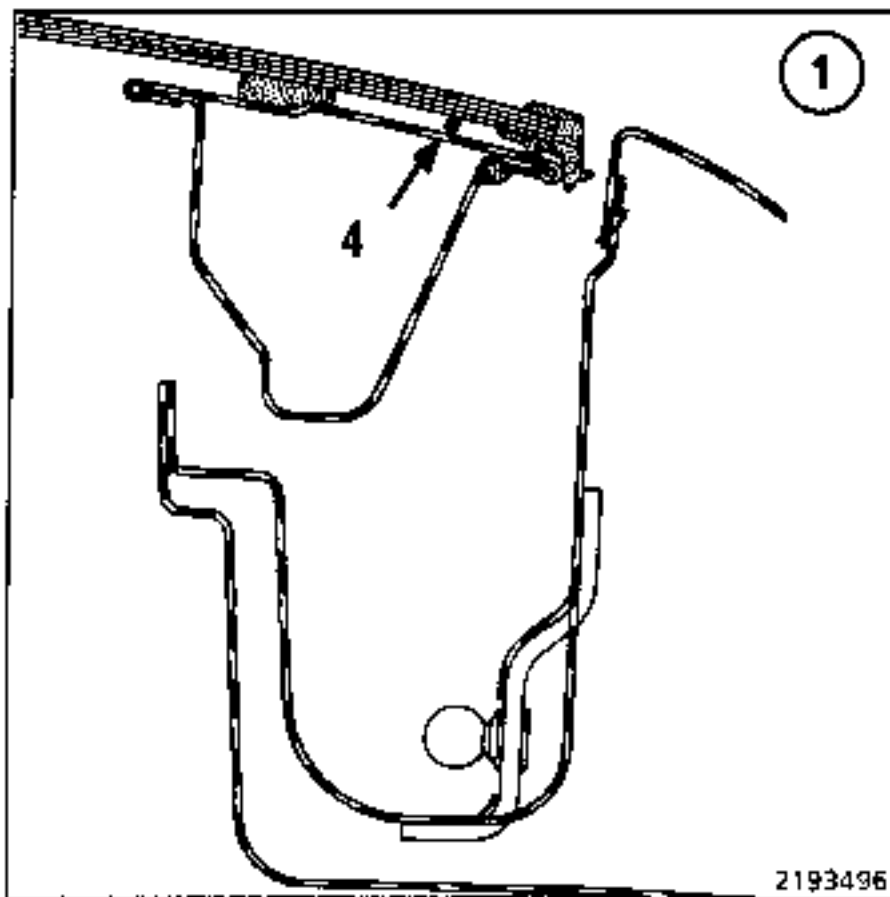

Use a piece of cutting wire 5 mm long.

In one of the lower corners and working from the outside towards the inside, pass approximately 15 to 20 cm of the wire through the mastic bead.

On the outside, pass the wire (4) under the moulding, all around the screen. Apply pieces of adhesive paper at regular intervals to ensure that it does not move.

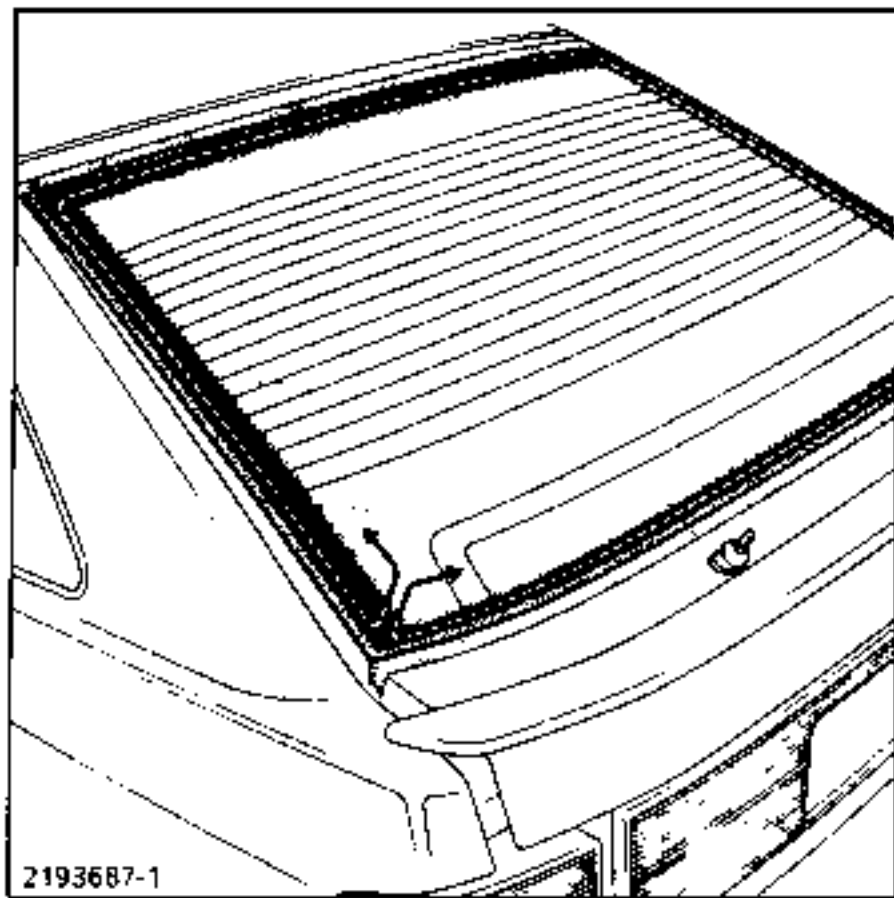

After cutting around the entire screen pass the other end of the wire through the mastic bead as shown in the drawing.

From the inside of the tailgate, fit in place the pulling handle and pricker tool. Cut the mastic bead without changing the position of the pricker tool.

As you cut, reduce the length of the wire at the handle and ensure that the wire passes correctly under the moulding so as not to damage it.

REFITTING

CLEANING THE WINDOW SURROUND

Using a spatula approximately 20-25 cm wide, the edge of which has been sharpened, cut and smooth down the mastic bead to leave a thickness of approximately 0.5 to 1 mm of mastic on the surround.

NOTE : It is essential to leave a film of mastic on the window surround to act as a key for the new bead.

Remove all mastic residue and dust by blowing it with an air gun.

NOTE : Only use dry air, free from all traces of oil.

As a general rule, no cleaning or degreasing product is to be used on the remaining film of mastic.

PREPARING THE NEW WINDOW

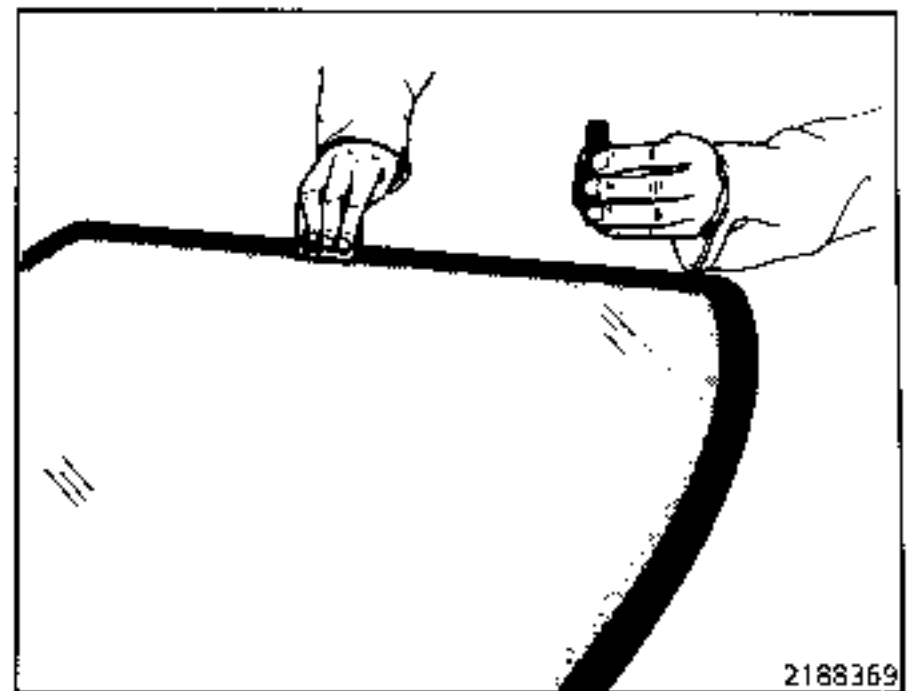

Carefully clean the enamelled surface around the entire periphery of the windscreen.

- 1) If possible, use de-mineralised water, wiping it off with a dry clean cloth.
- 2) Then, use a degreasing solvent, using the special cloth supplied in the kit.

Apply glass primer over the entire enamelled area of the upper and lower edges and over a 30 mm wide strip in the centre of the enamelled area on the sides.

PREPARING THE WINDOW SURROUND

Apply metal primer to those parts of the surround that have been damaged back to the bare metal during the removing or cleaning operations.

Using a mallet, fit a new anti-overflow seal.

FITTING THE SCREEN

Apply a bead of bonding mastic with a triangular cross-section to the screen. Centre the mastic bead in relation to the strip of primer. Using a spatula, smooth down the join where the ends of the mastic bead meet. Using suction pads, fit the screen in place centring it at the sides. Reconnect the tabs for the heated screen.

NOTE : As the vehicle cannot be driven for at least 3 hours, we strongly recommend that this period be used to pour water around the periphery of the screen both to detect any leaks and to accelerate the curing of the mastic, which is of the moisture-cured type.

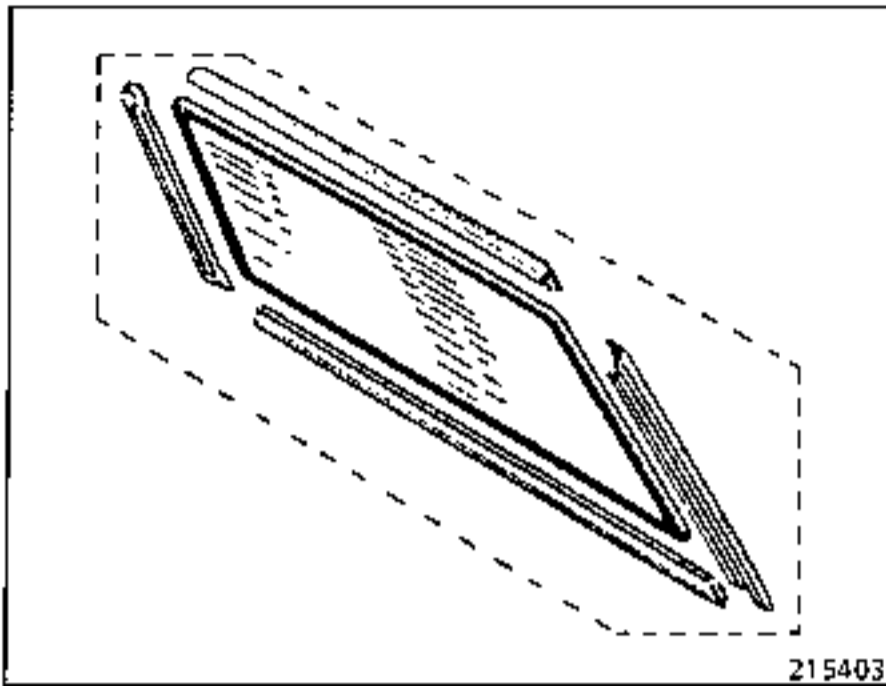

DEPOSE

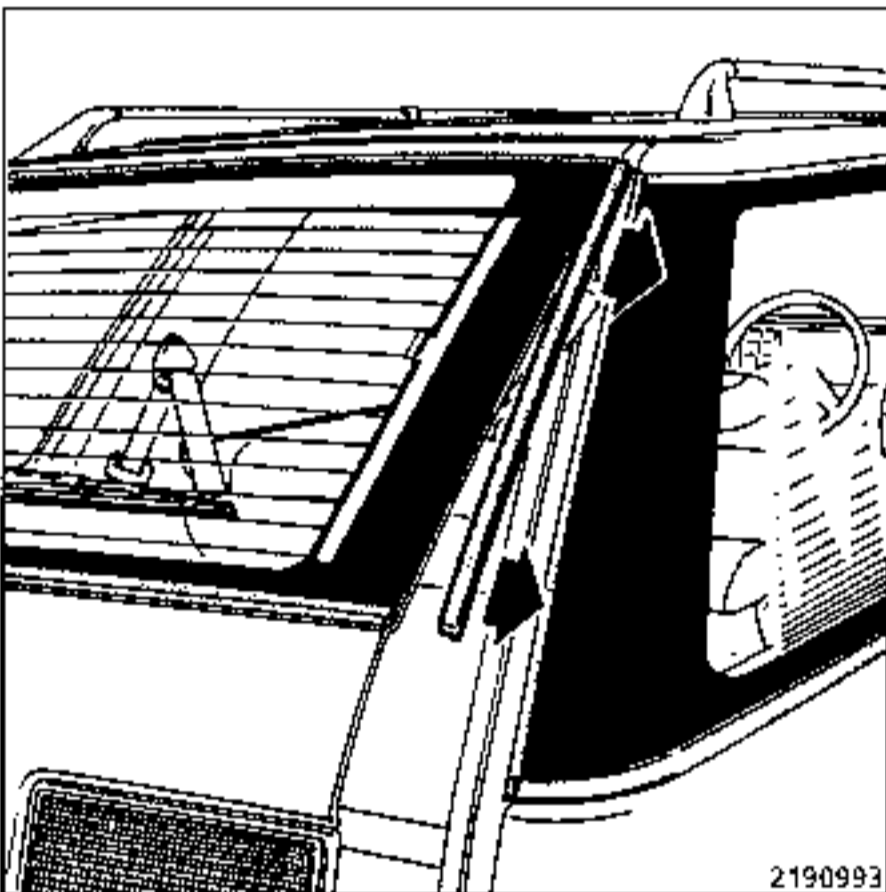

Pull the mouldings to remove them (there are no positive mountings).

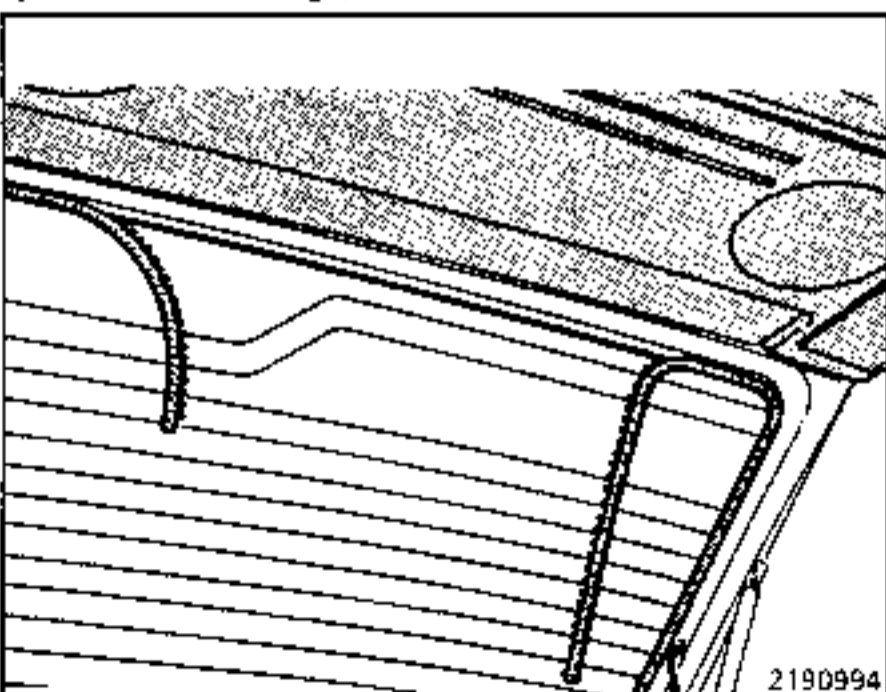

Disconnect the tabs for the power supply to the heated screen. Pull on the anti-overflow seal to remove it.

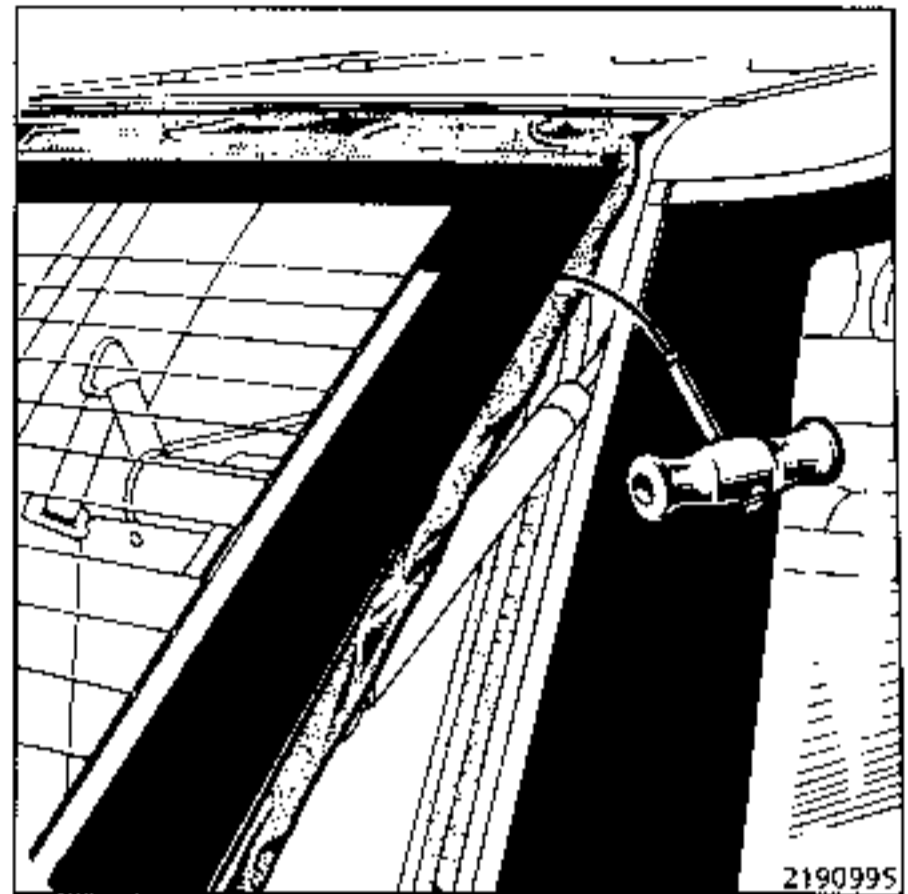

Using adhesive tape, protect the bodywork around the edge of the screen.

Pass a piece of steel wire approximately 30 cm long through the mastic bead.

Fit in place the pricker tool and pulling handle and cut the mastic bead. In the corners take care that the wire passes correctly under the mouldings.

CLEANING THE WINDOW SURROUND

Using a spatula approximately 20-25 cm wide, the edge of which has been sharpened, cut and smooth down the mastic bead to leave a thickness of approximately 0.5 to 1 mm of mastic on the surround.

NOTE : It is essential to leave a film of mastic on the window surround to act as a key for the new bead.

Remove all mastic residue and dust by blowing it with an air gun.

NOTE : Only use dry air, free from all traces of oil.

As a general rule, no cleaning or degreasing product is to be used on the remaining film of mastic.

PREPARING THE WINDOW SURROUND

Apply metal primer to those parts of the surround that have been damaged back to the bare metal during the removing or cleaning operations.

Do not apply this primer to the remaining film of mastic. If necessary, re-cut the applicator with a pair of scissors

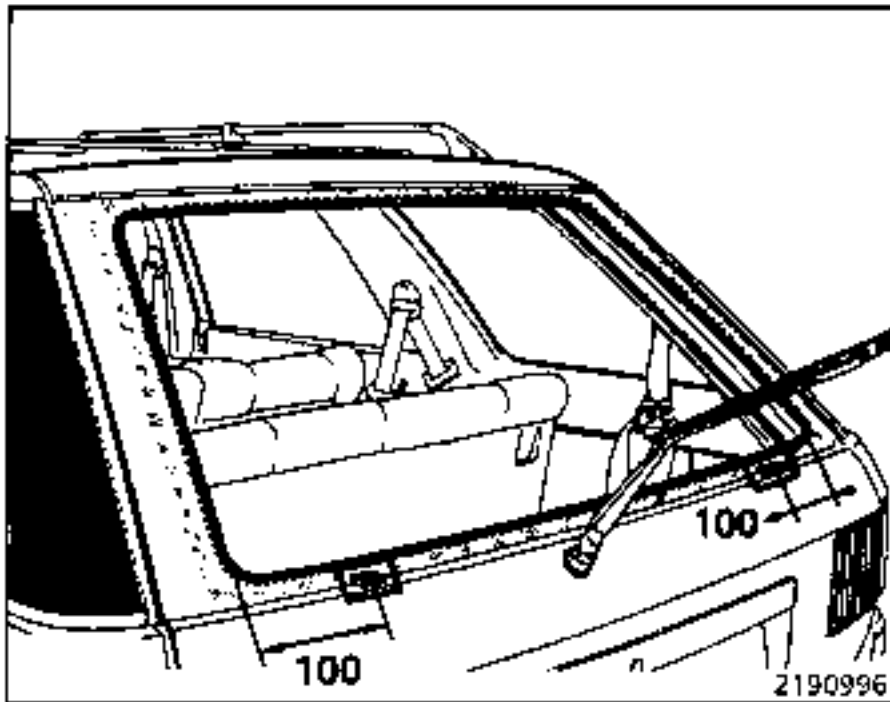

Using a rubber mallet tap the anti-overflow seal onto the screen surround (with the clips on the outside of the vehicle).

Fit the lower pads as shown in the above illustration.

PREPARING THE NEW SCREEN

Carefully clean the enamelled surface around the entire periphery of the screen.

- 1) If possible using de-mineralised water, wiping it with a clean, dry cloth.
- 2) Then with degreaser, using the special cloth supplied in the kit.

A Using the pad, apply the glass primer to the enamelled surface to the following dimensions :

- approximately 10 mm from the inner edge of the enamel over a 20 mm width on the upper and lower edges,
- approximately 20 mm from the inner edge of the enamel over a width of 20 mm on the two side edges.

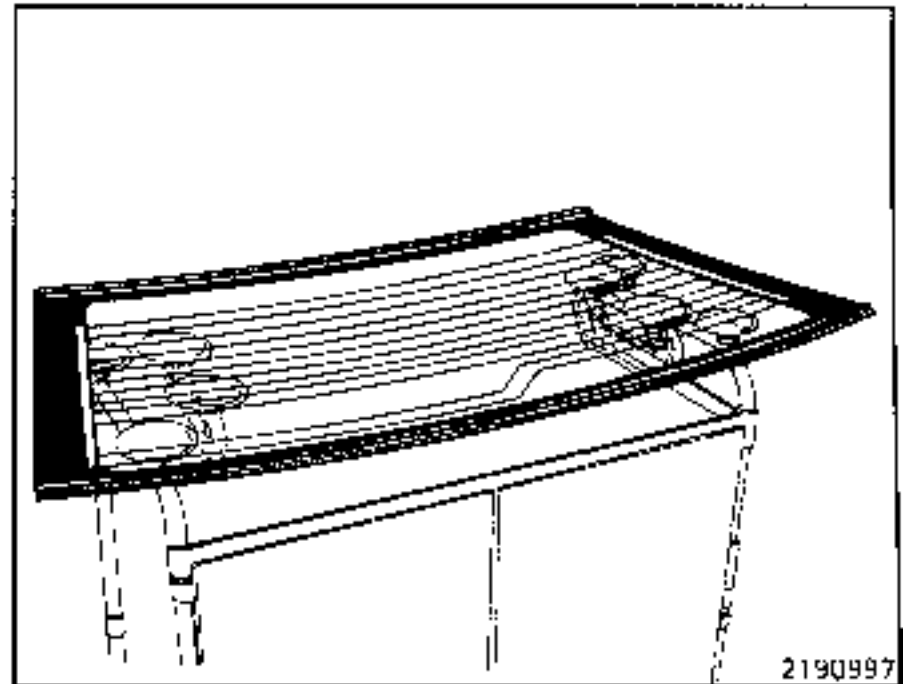

Fit the upper and lower mouldings to the edge of the screen, pushing them down to approximately half the depth of the U shape.

Offer up the screen to the vehicle.

Rectify the positions of the mouldings to obtain a clearance of approximately 2 mm between them and the window surround.

REFITTING

Pierce the membrane on the mastic cartridge and screw on the nozzle pre-cut to a triangular shape.

NOTE : If you do not have this nozzle, cut the one found in your kit so as to obtain a triangle with a base approximately 7 mm long and height 10 mm.

Pierce the bottom of the cartridge.

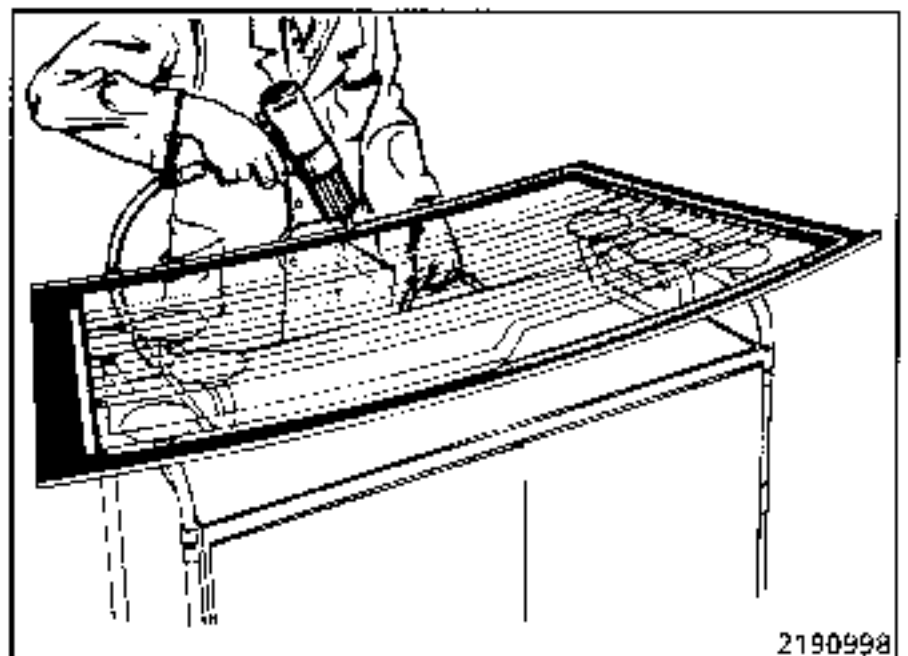

Using a spray gun, apply a bead of mastic to the primer strip, using the mouldings as a guide on the upper and lower edges..

Using the suction pads, place the screen on the vehicle parallel with the window surround.

Adjust the position of the screen laterally and hold it in place with wide adhesive tape.

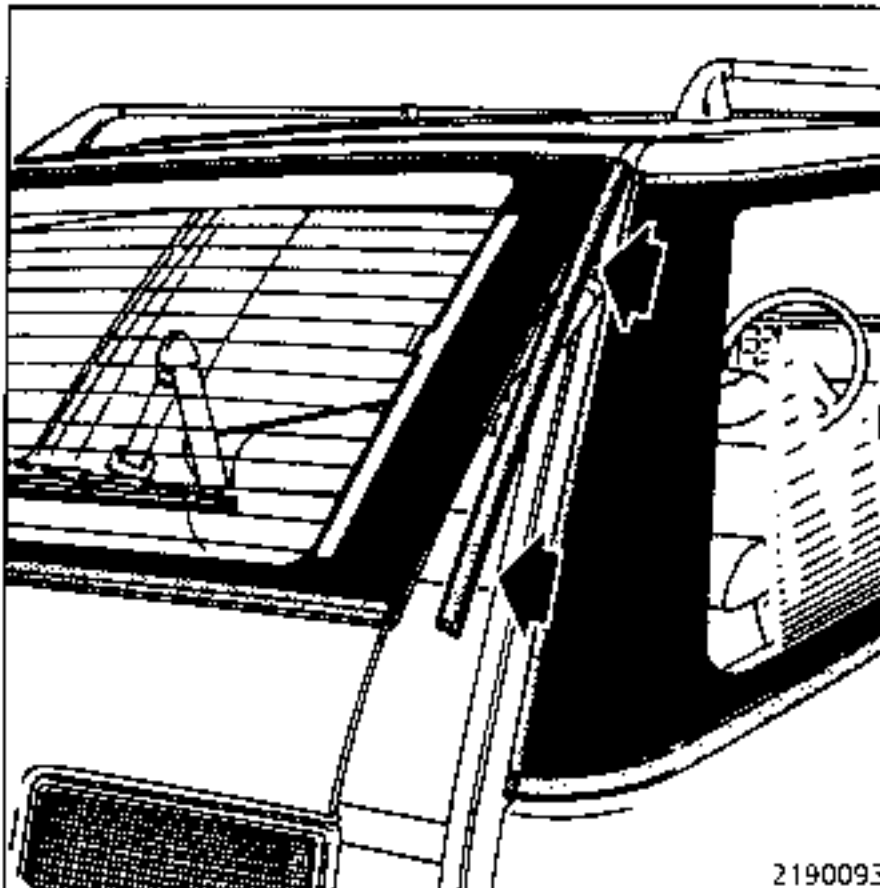

Fit the side trim pieces to the screen and adjust the position of the screen to bring it in line with the quarter lights..

NOTE : As the vehicle cannot be driven for at least 3 hours, we strongly recommend that this period be used to pour water around the periphery of the screen both to detect any leaks and to accelerate the curing of the mastic, which is of the moisture-cured type.

REMOVING THE WINDOW

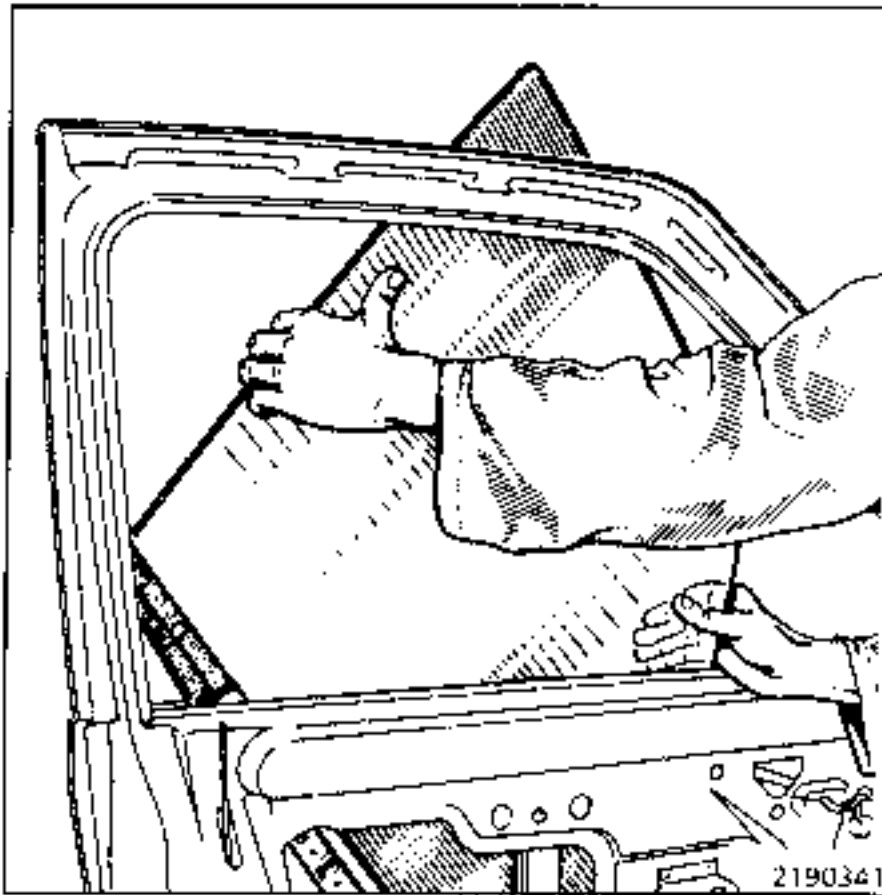

NOTE : The mechanism does not have to be replaced when replacing the window.

Tilt the window as shown in the drawing above.

The mobile section of the rail is at the bottom.

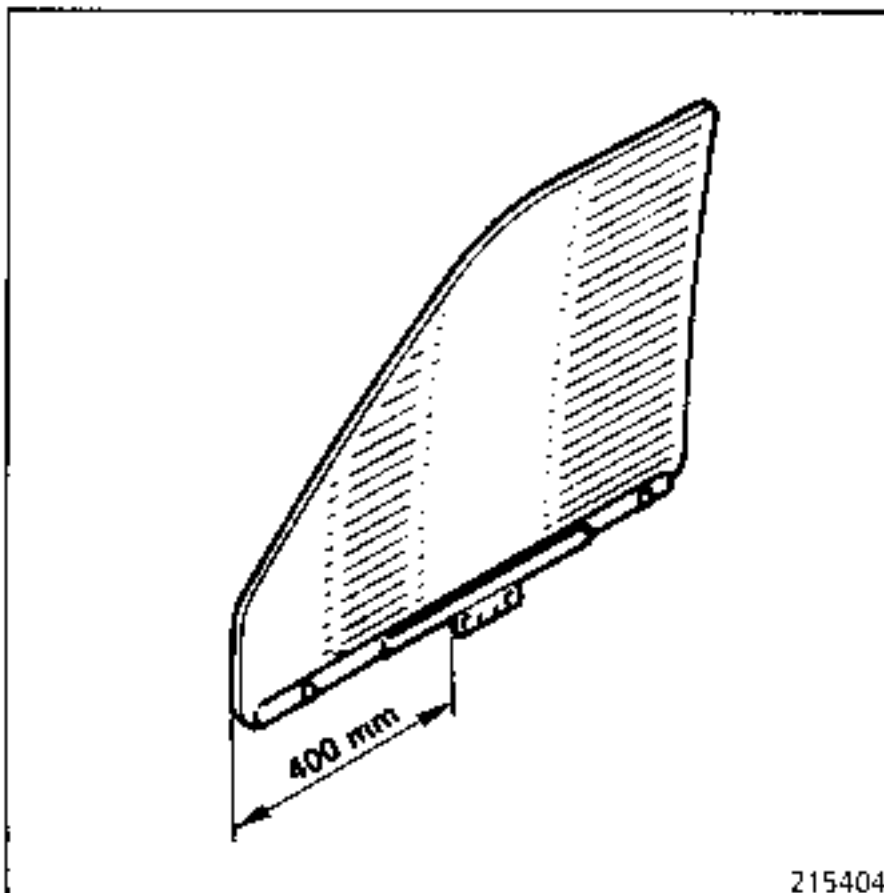

Dimension for the bottom of the window.

REMOVING THE WINDOW

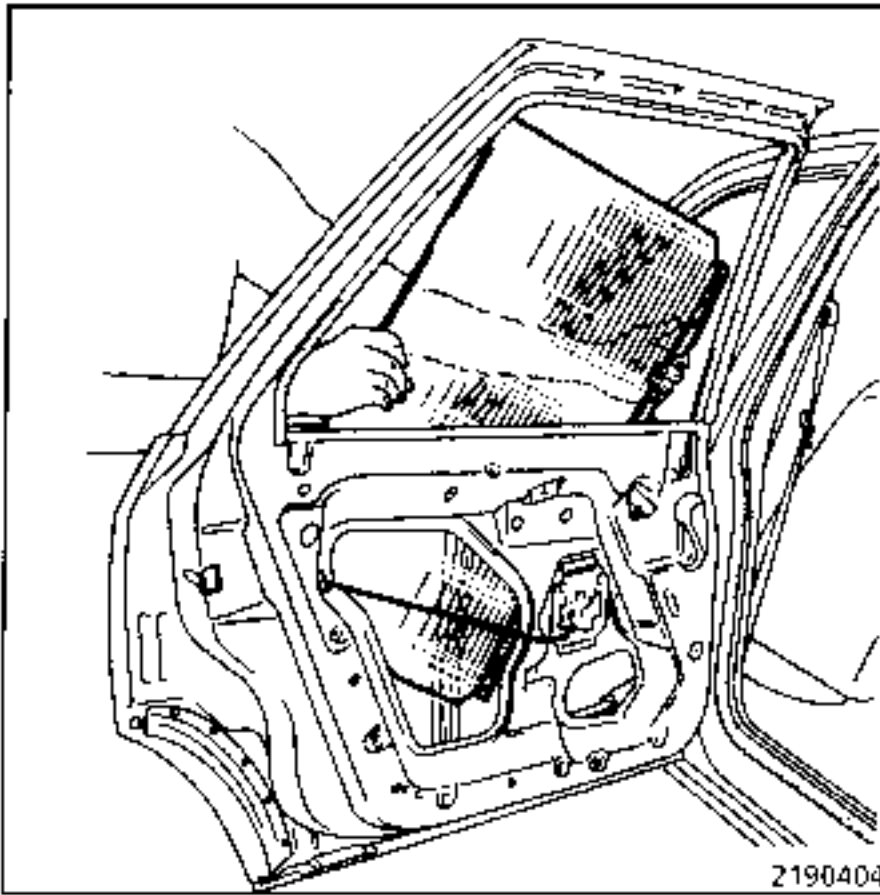

NOTE : The mechanism does not have to be replaced when replacing the window.

Tilt the window as shown in the drawing above.

The mobile section of the rail is at the bottom.

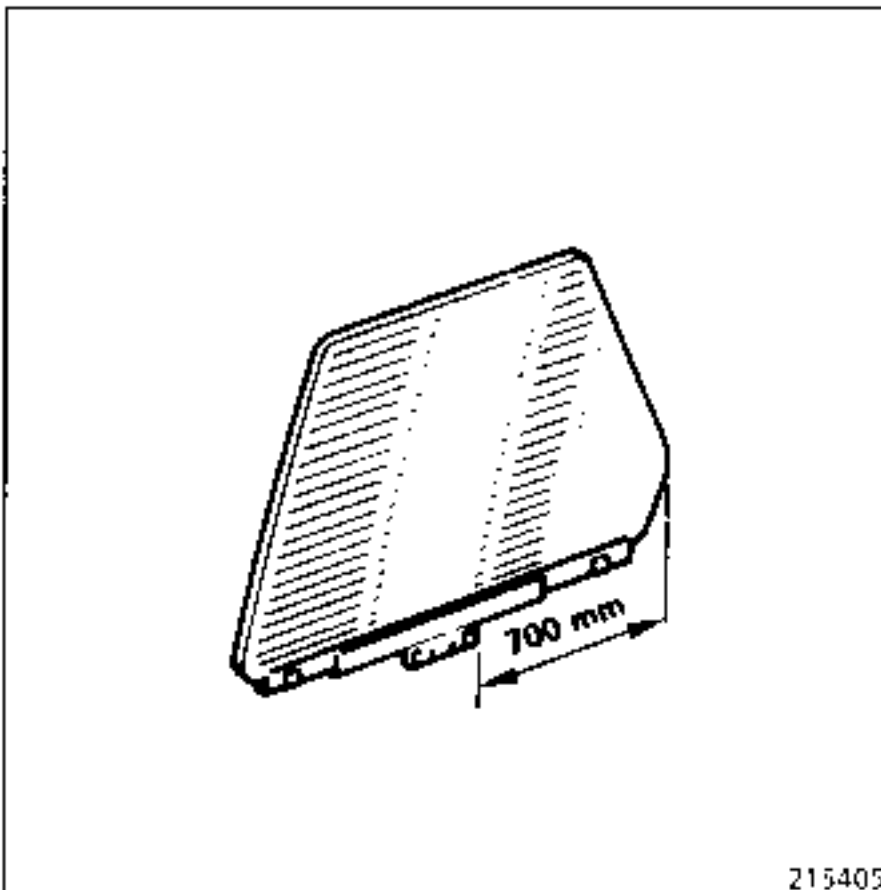

Dimension for the bottom of the window.

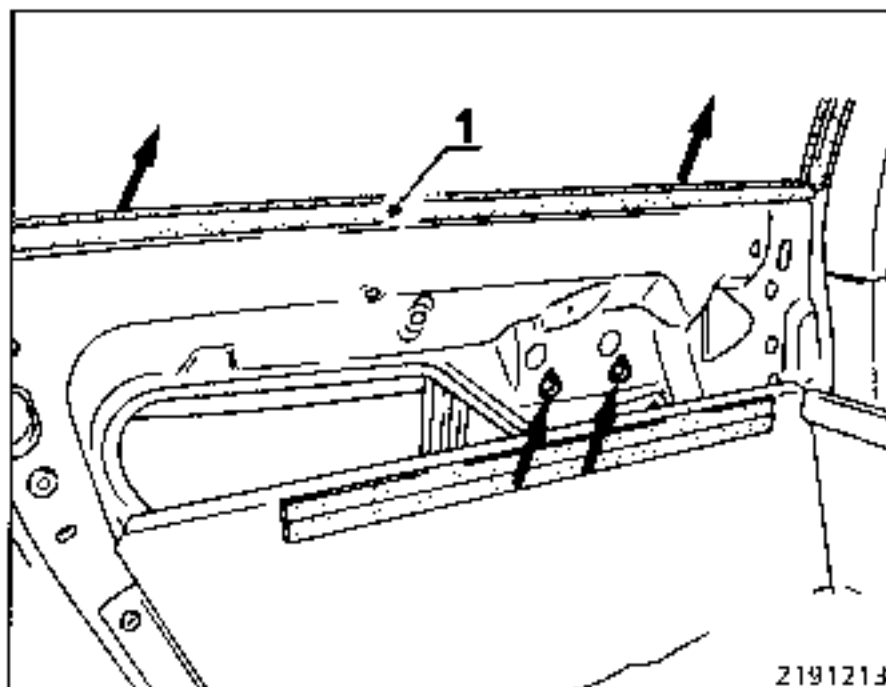

REMOVING THE WINDOW

The window in the rear door is retained in the raised position by a window support bolted to the door and to the bottom of the window (the mechanism has been removed).

The window is removed by removing the window support mountings from the door and the mountings for the bottom of the window from the window support.

Lower the window into the door.

Remove the inner rubbing strip (1) and the inner and outer frame seals.

Take out the window from the outside of the door.

NOTE : The door does not have to be opened in order to remove the window.

Remove part of the spoiler in the vicinity of the shield mounting (1).

Remove the right-hand and left-hand sections of the protection skid so that shield bolts (4) can be reached.

Remove :

- bolts (1), (2), (3), (4).

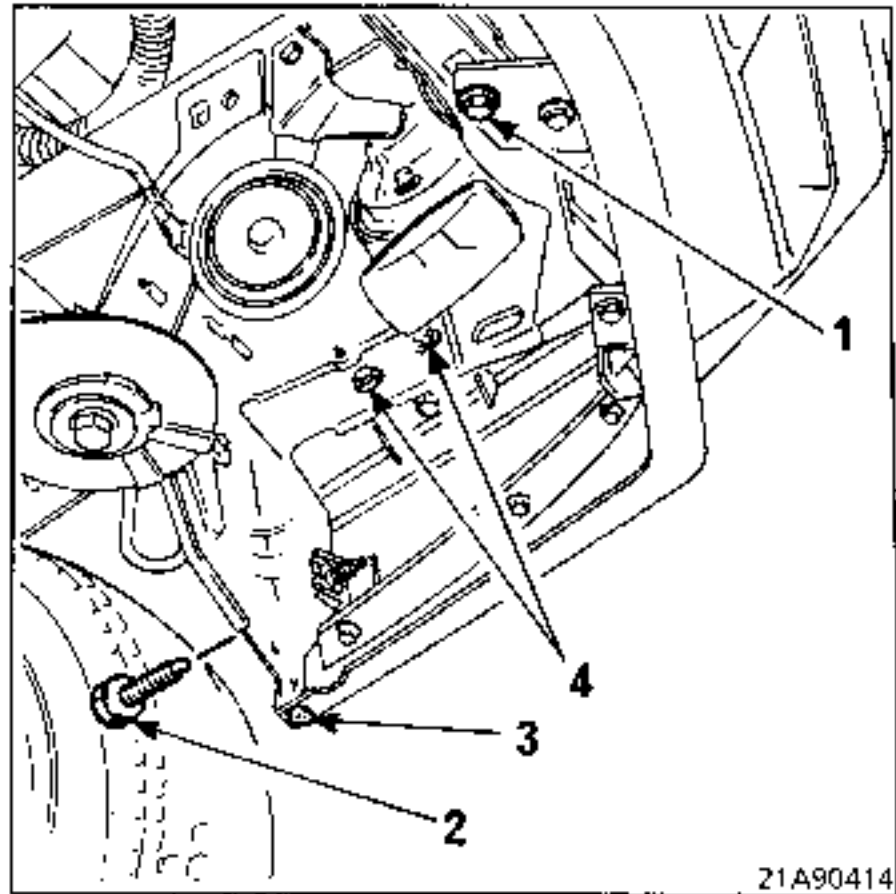

Phase 1 - Rear bumpers

Left-hand side



Remove :

- the side mountings, located behind the side panel trim,
- the mud flap outer mounting.

Right-hand side

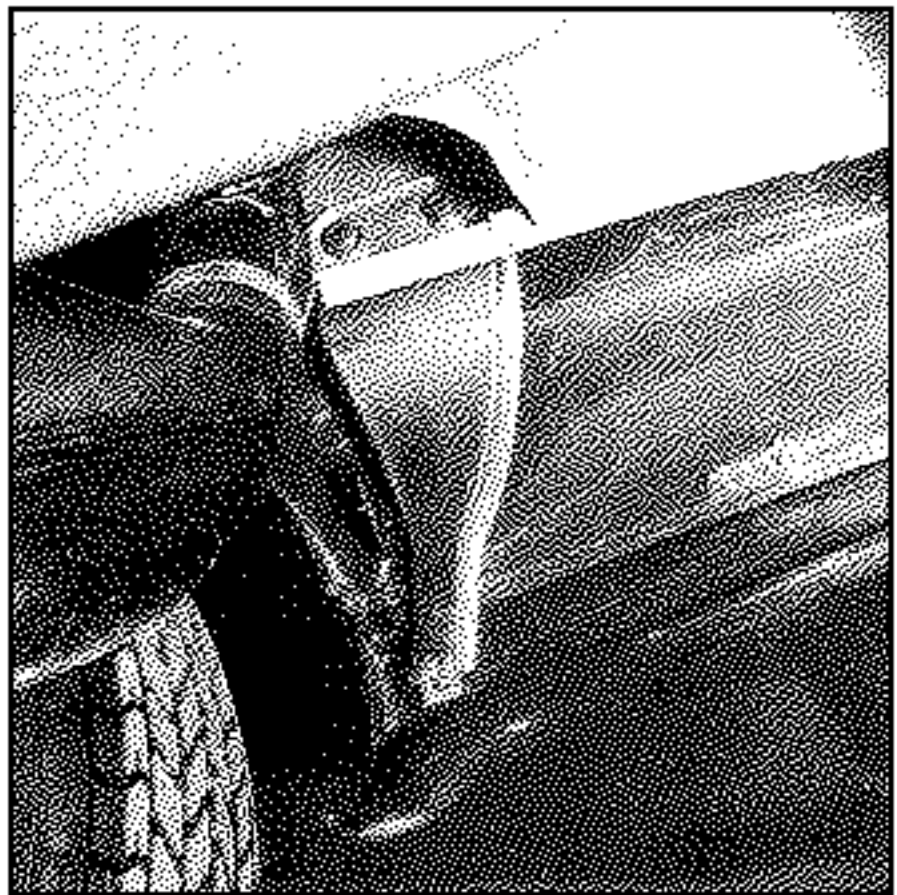

Remove:

- the side mountings which can be reached through the wheel arch,
- the shield, by pulling it backwards. The impact absorbing pads are not secured.

REMOVAL

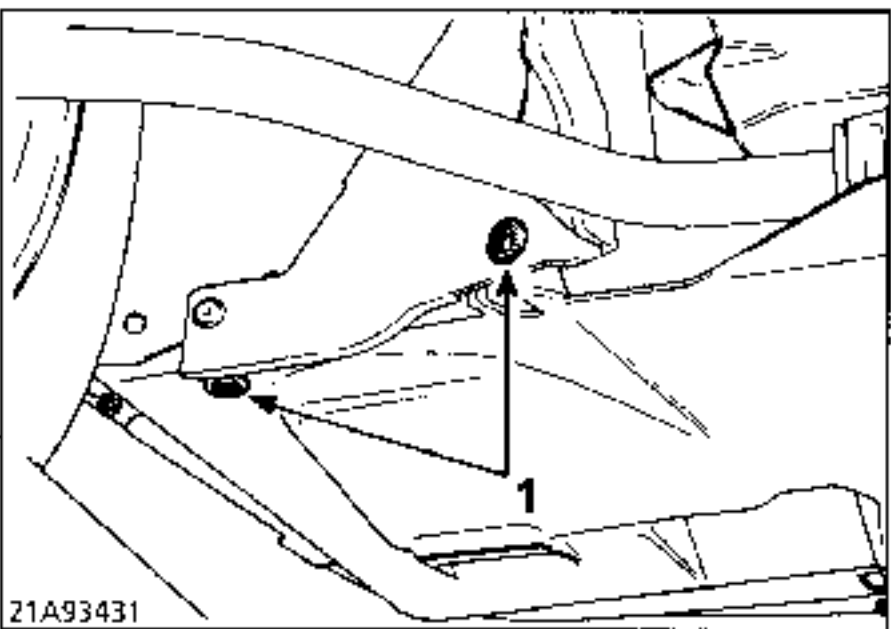
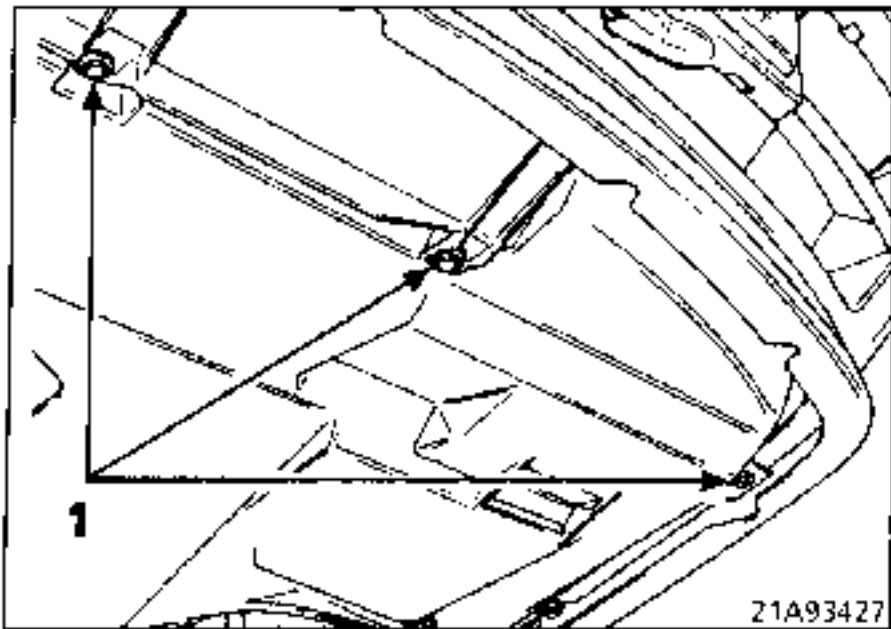

- Remove :
- the two bolts (1) holding the engine undertray in place,

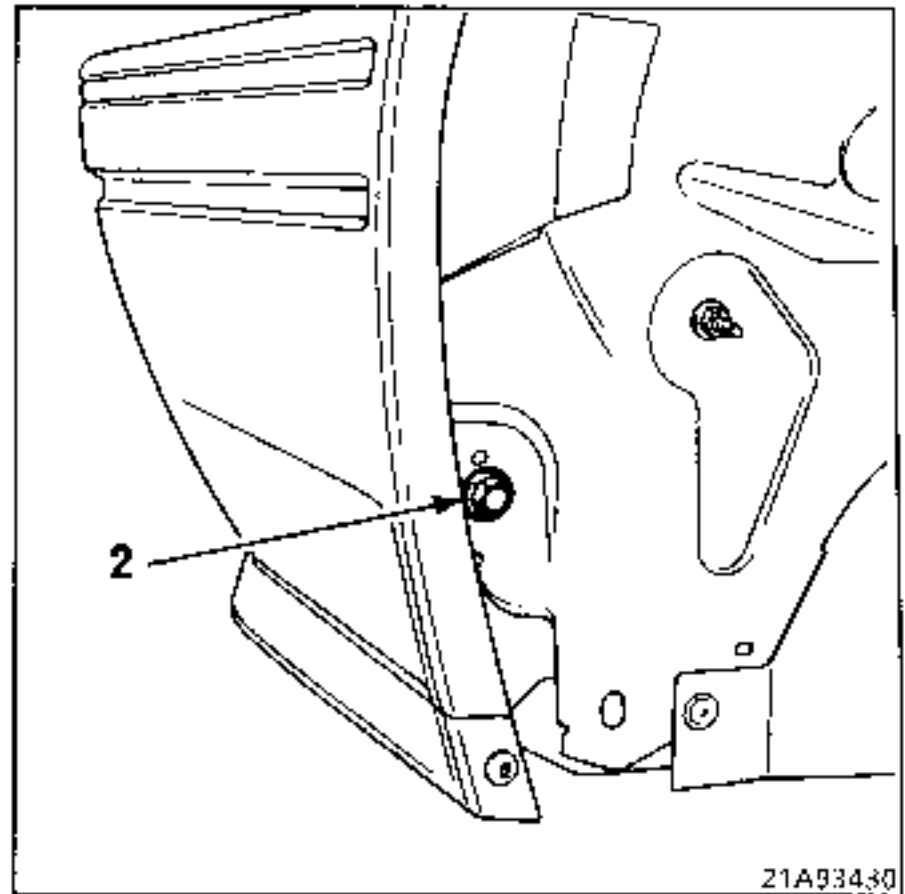

- the two bolts (2) for the rear mounting.

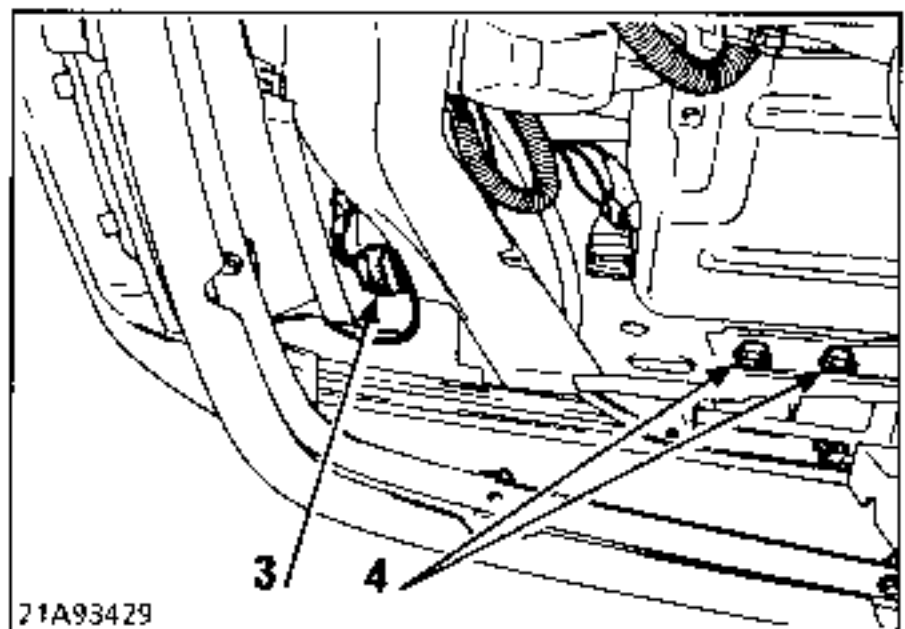

- Disconnect the fog light connector (3).
- Remove the four side mounting bolts (4) and remove the shield.

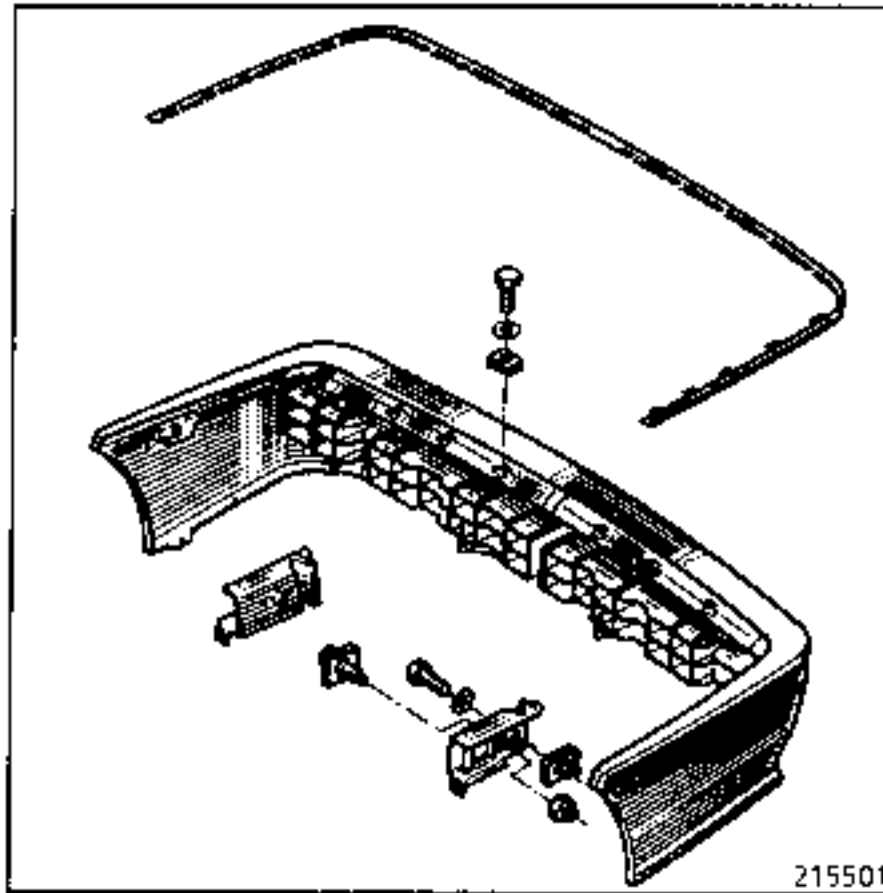

REMOVAL

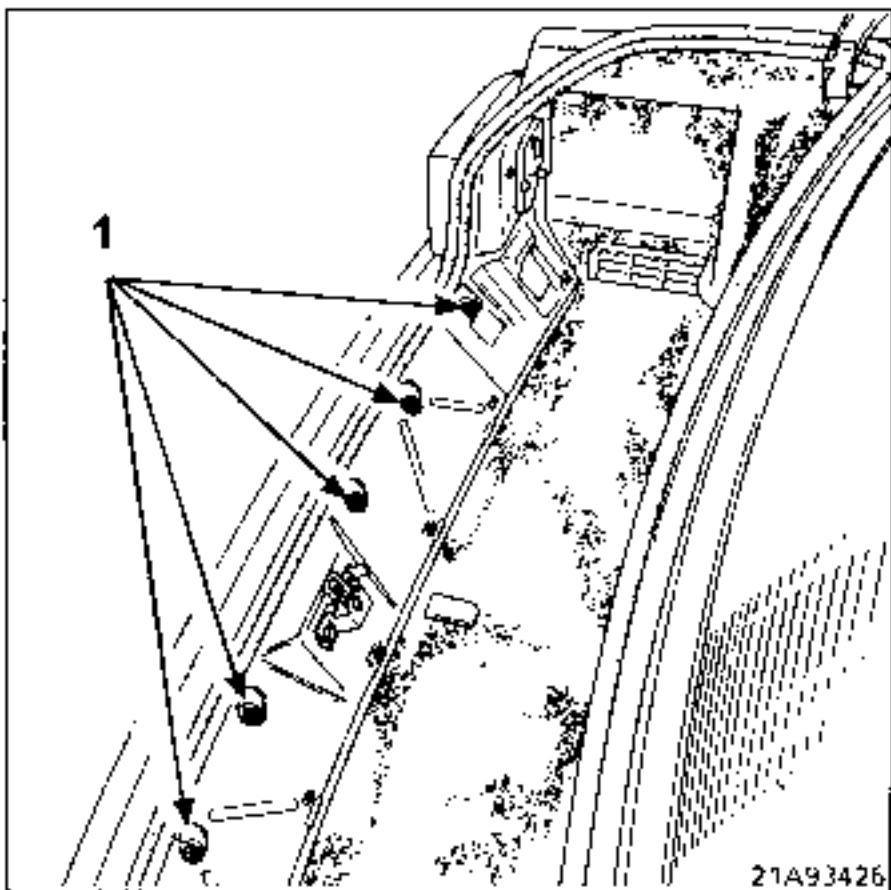

Remove:

- the inner trim from the rear end panel secured by nine Torx type bolts,
- the six bolts (1) securing the top of the shield,

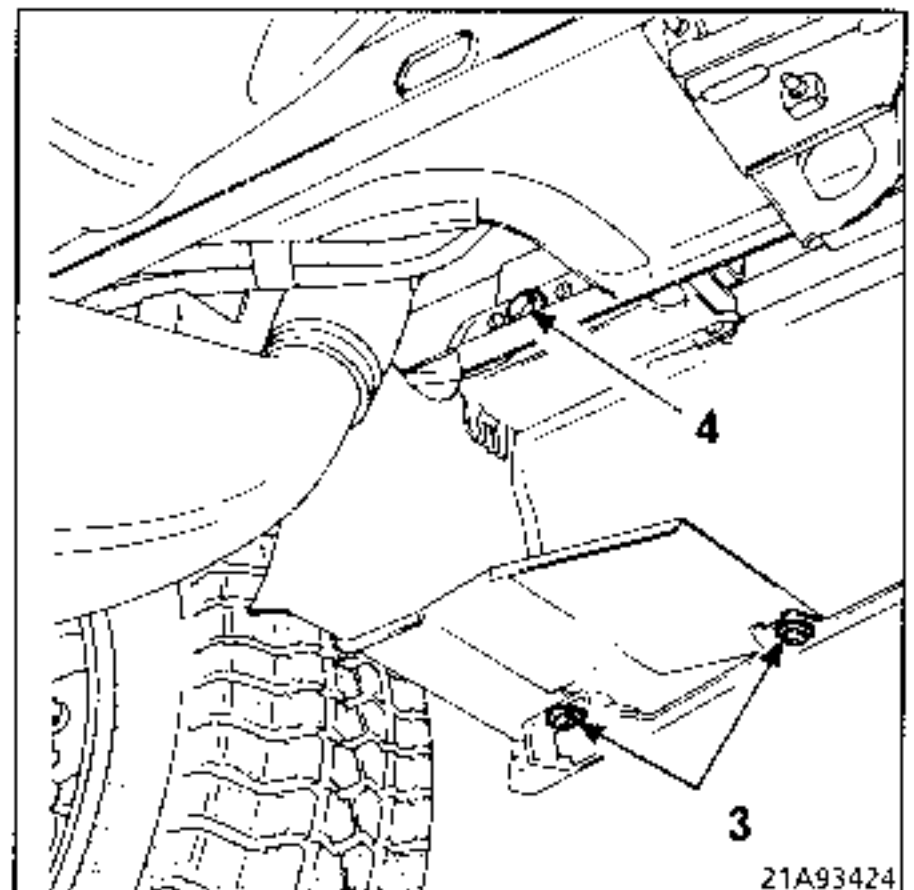

- the four bolts (3) securing the wheel arch protectors,
- on the right-hand side, bolt (4) for the side mounting,

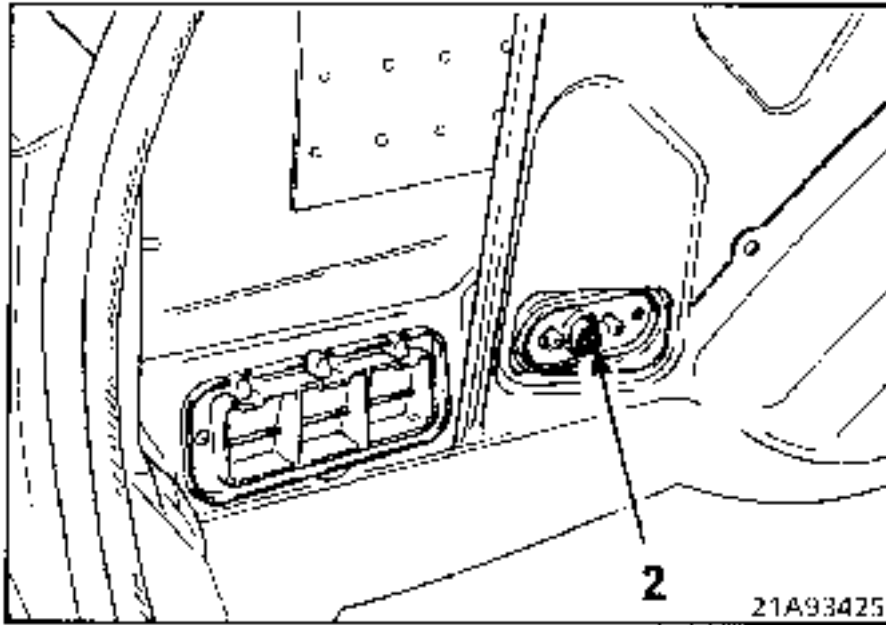

- remove the left-hand side mounting bolt (2), after moving away the wheel arch trim,

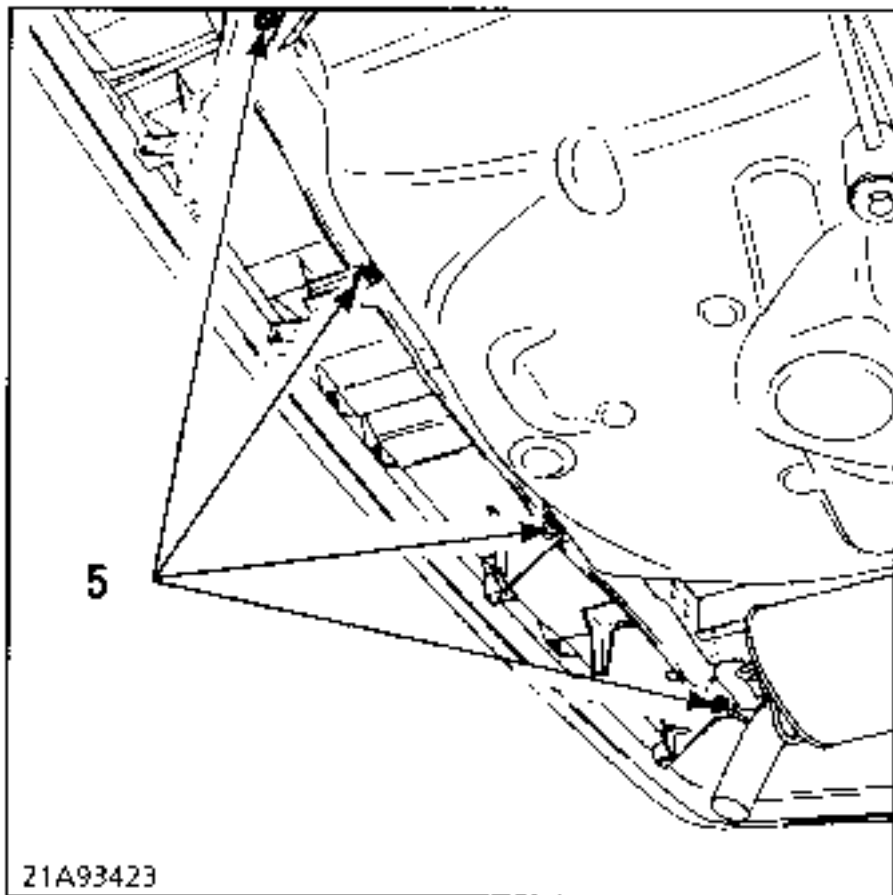

- the four bolts (5) on the lower cross member,
- the shield.

REMOVAL

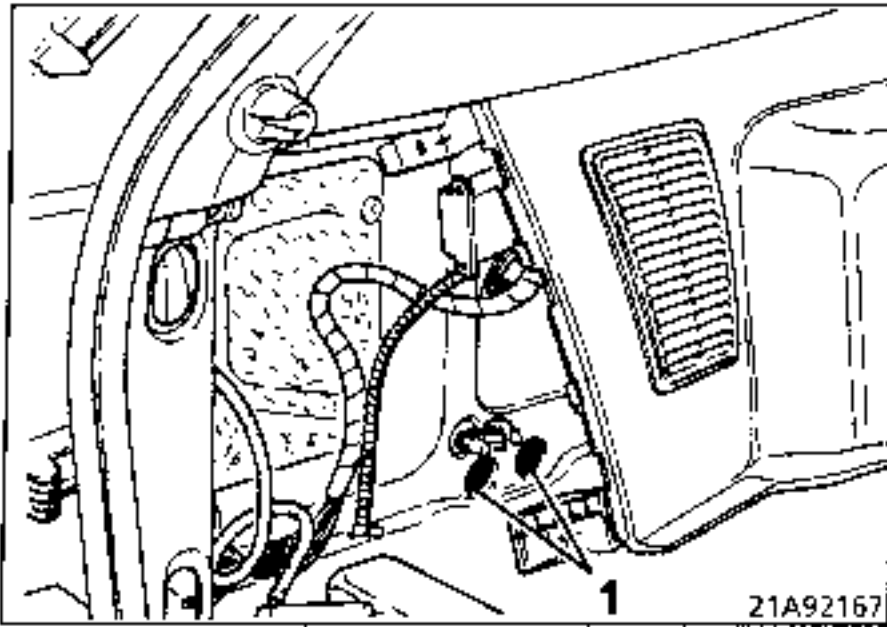

Remove the small door supporting the windscreen washer bottle.

Move aside the wheel arch trim.

Remove the left-hand side mounting bolts (1).

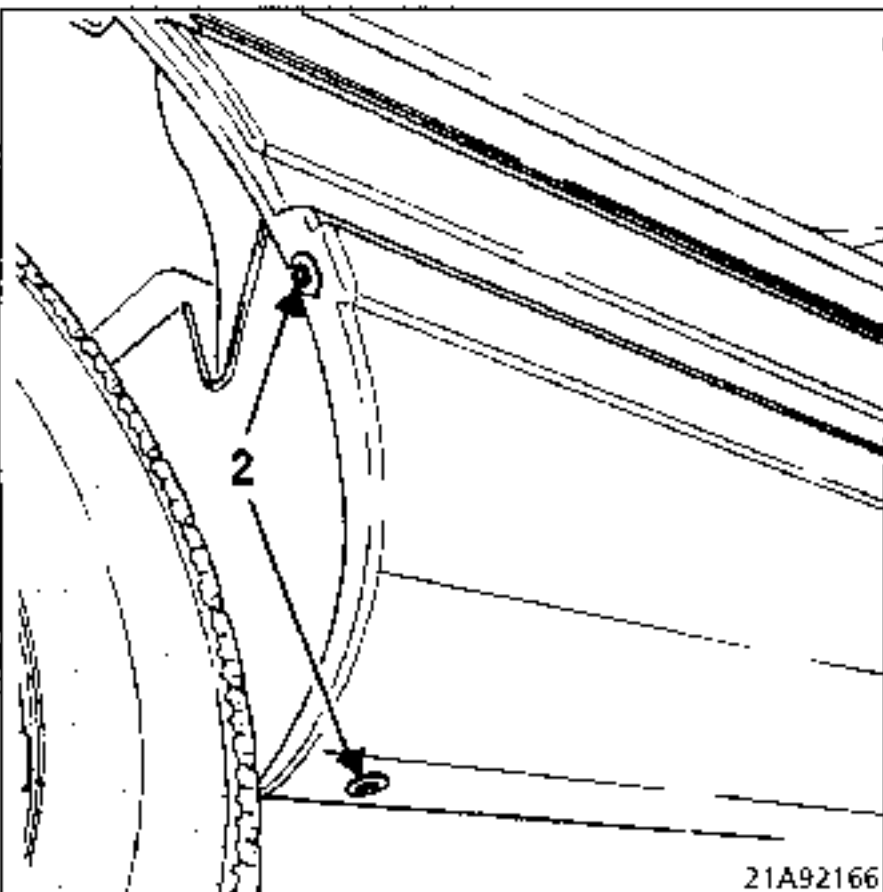

On the left-hand and right-hand sides, remove the two bolts (2) securing the plastic protectors for the wheel arches.

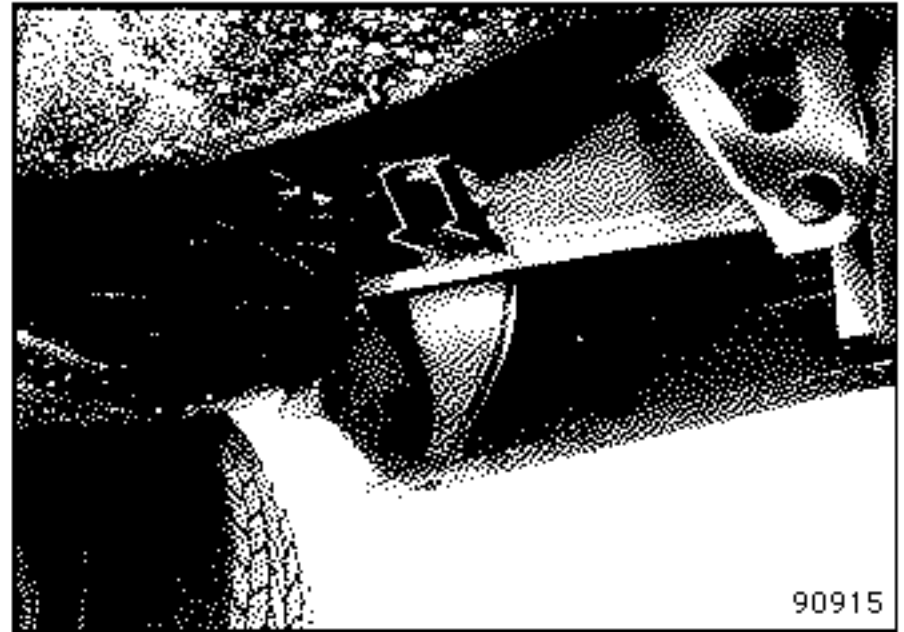

From underneath the vehicle, remove the two right-hand side mounting bolts (3).

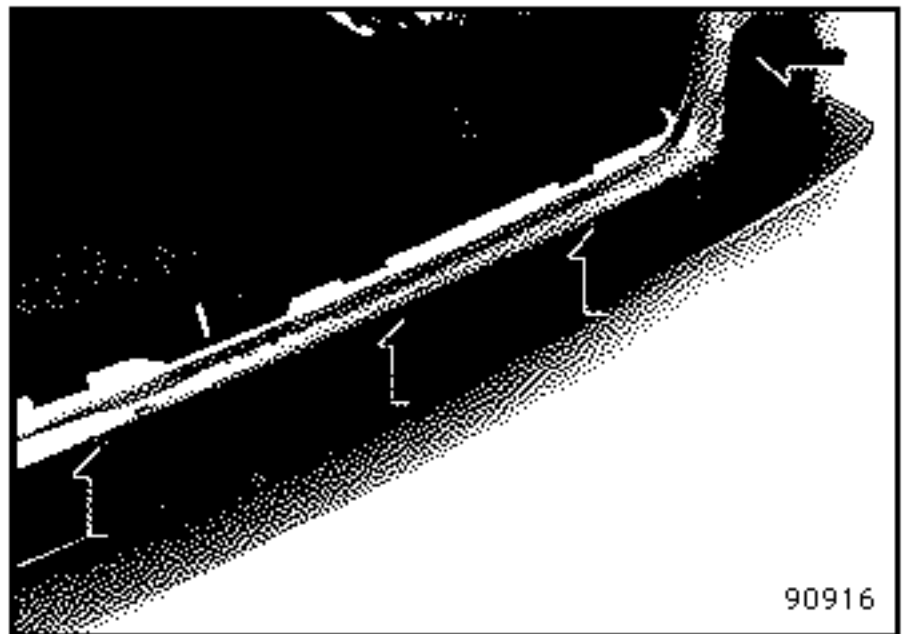

Remove the upper mounting bolts and take off the shield, pulling it backwards.

REMOVAL

Drill :

- rivet head (1) securing the rear end of the spoiler,

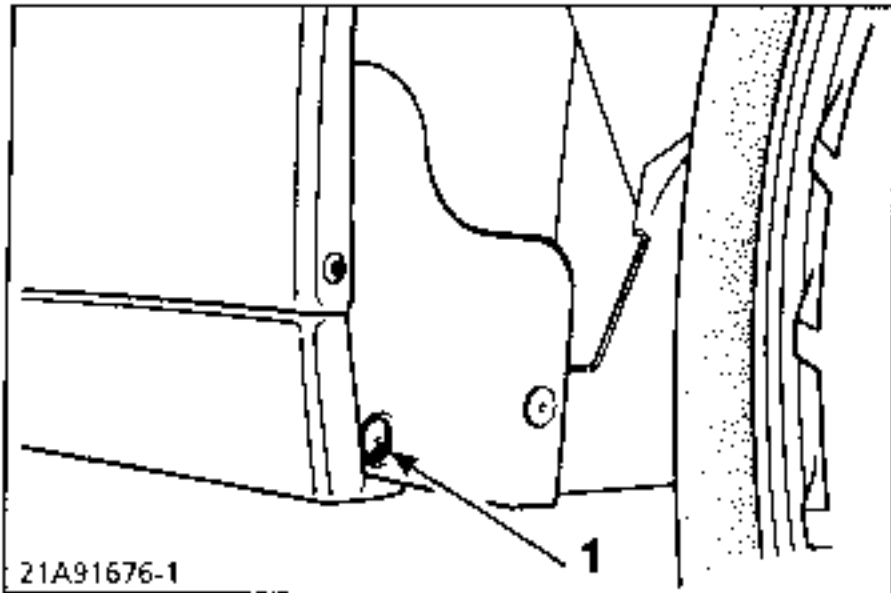

- the 3 rivet heads (2) securing the spoiler to the lower cross member by means of metal lugs (3).

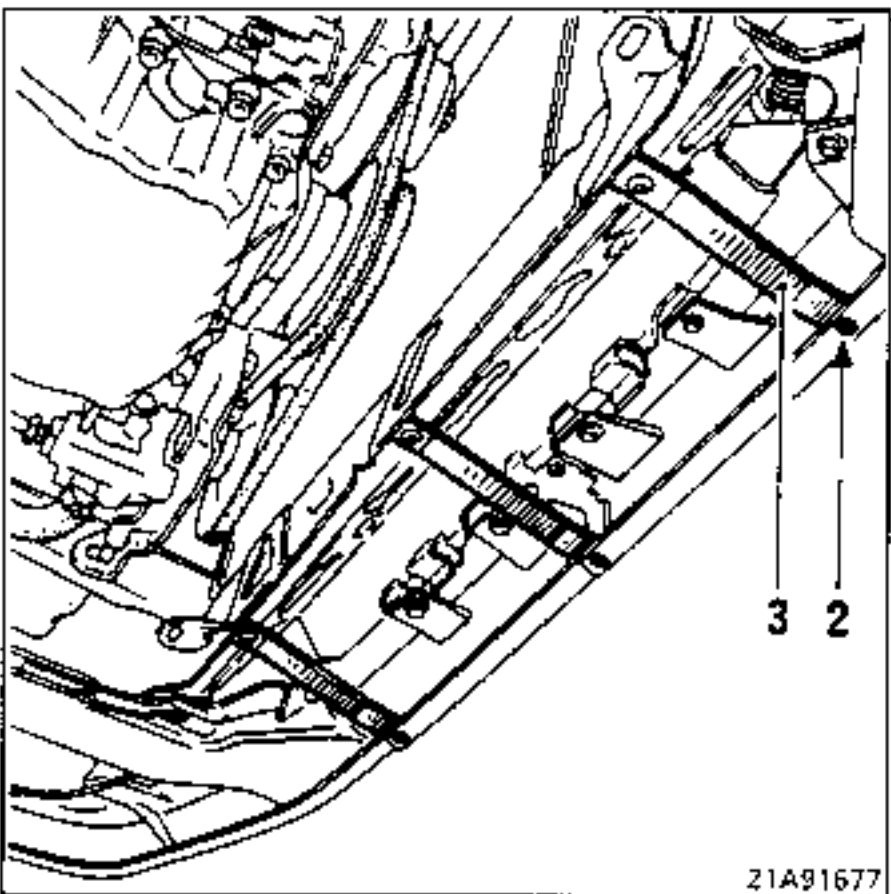

Remove :

- the bolts (4) securing the air ducts to the spoiler,

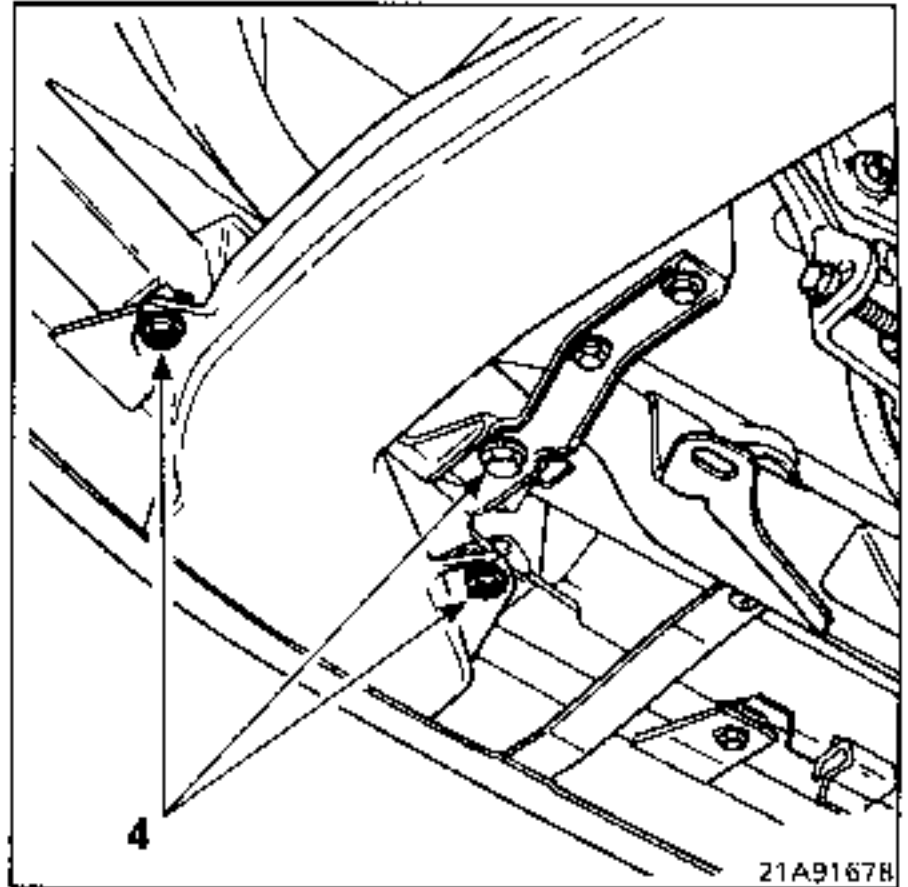

- the two bolts (5) securing the sides of the shield.

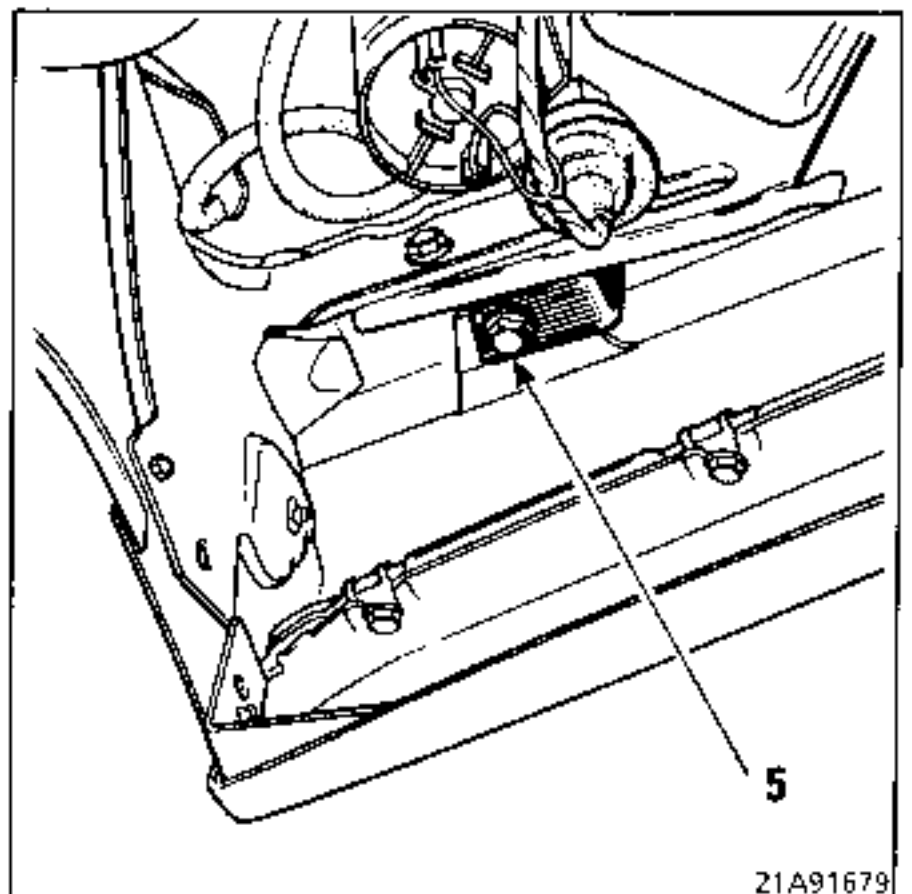

There are 2 types of spoiler, depending on the shape of the shield :

1st version

Shield with ventilation grille

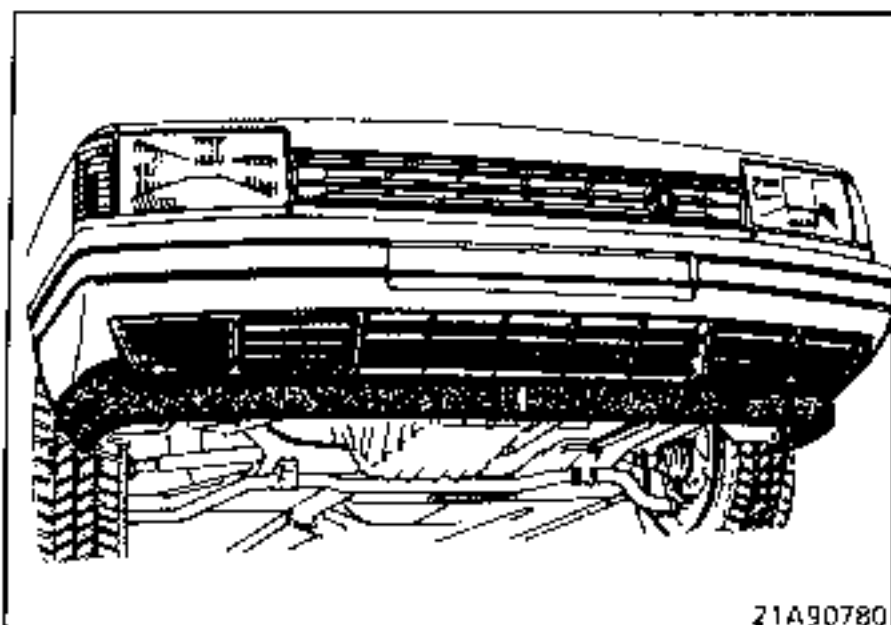

The kit consists of :

- 1 right-hand 1/2 component,
- 1 left-hand 1/2 component,
- 1 sachet.

The sachet contains :

Mark	Quantity
2 rivet C6 - 9.3	77 03 072 236 2
3 base screw M6 x 100	77 03 002 020 16
4 sheet metal nut 4.2	77 03 046 069 3
5 Aluminium rivet C3 4.8 - 13	77 03 072 202 2
6 sheet metal nut M6 AC200/4	77 03 046 034 16
7 sheet metal RLX bolt 4.2 (black stainless steel)	77 03 016 340 3
8 base screw M8 x 125	77 03 020 006 2
9 sheet metal nut M8	77 03 046 020 2

2nd version

Shield without ventilation grille

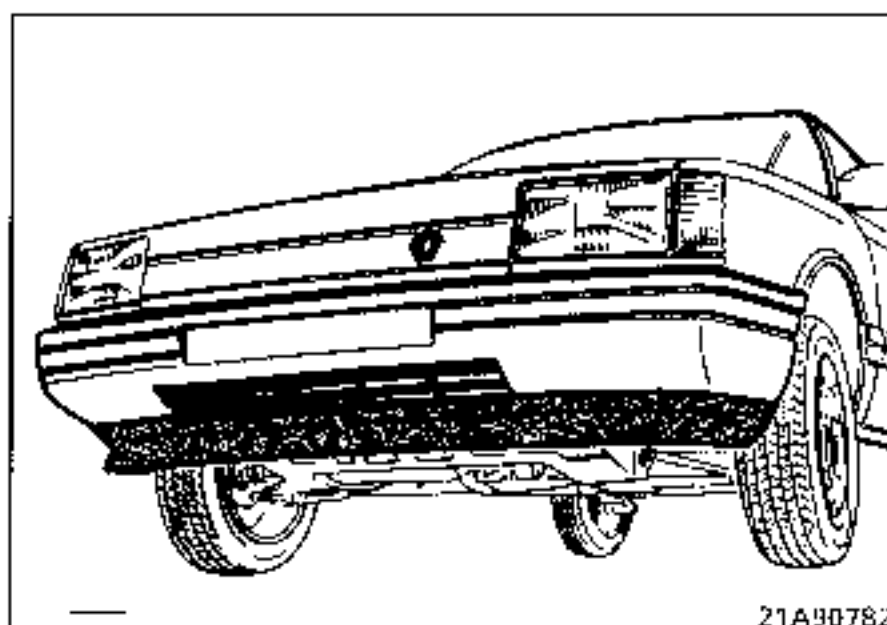

The kit consists of :

- 1 right-hand 1/2 component,
- 1 left-hand 1/2 component,
- 1 sachet.

The sachet contains :

Mark	Quantity
1 base nut M6	77 03 035 015 4
2 rivet C6 - 9.3	77 03 072 236 2
3 base screw M6 x 100	77 03 002 020 10
4 sheet metal nut M6 x 100	77 03 046 034 10
5 Aluminium rivet C3 4.8 - 13	77 03 072 202 2
6 sheet metal nut 4.2	77 03 046 069 3
7 sheet metal RLX bolt 4.2 (black stainless steel)	77 03 016 340 3
8 base screw M8 x 125	77 03 020 006 2
9 sheet metal nut M8	77 03 046 020 2

1st version

On assembly, it is essential to follow the order as given below. This is due to the special way in which components B and C are clipped under the ventilation grilles on shield A.

To fit component C, it must be positioned simultaneously under the ventilation grille whilst B and C are connected.

IMPORTANT

Fit in order B to A, then C to A and connect B with C.

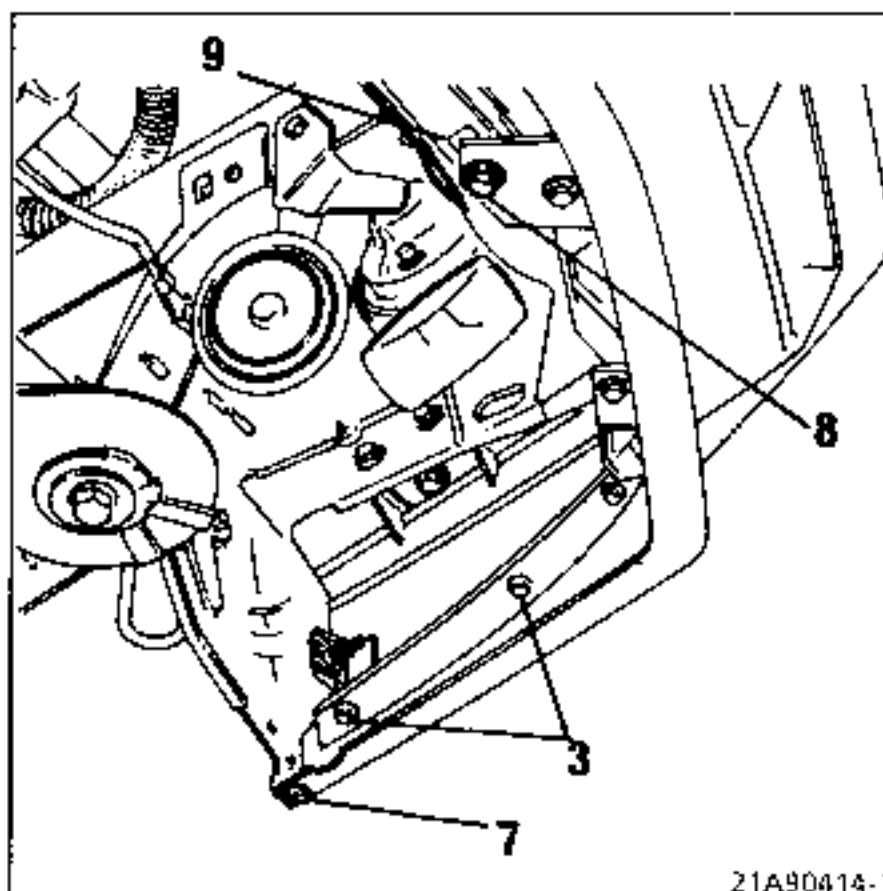
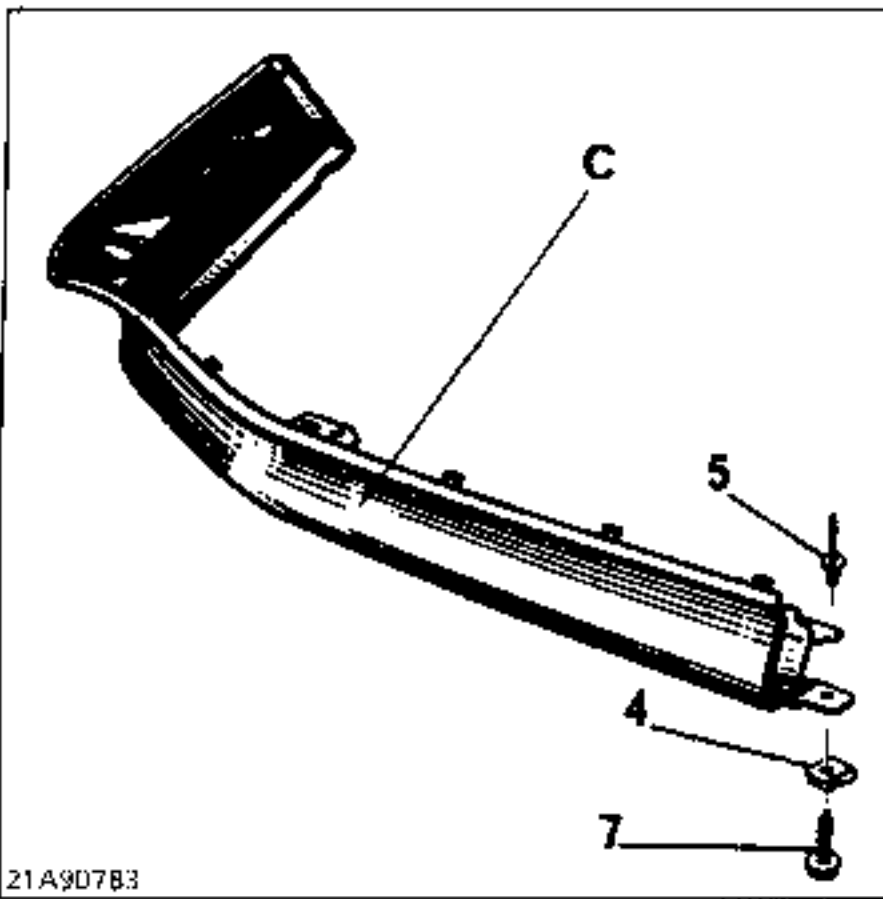

2nd version

Shield without ventilation grille. The two components can be assembled before they are secured to the shield, which makes it easier to fit rivet (5), bolt (7) and sheet metal nut (4).

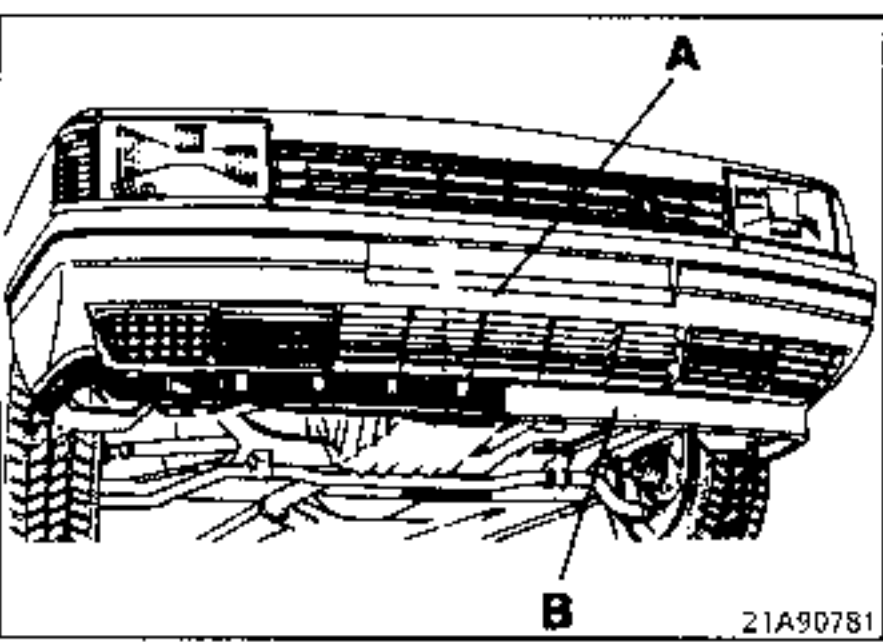

Fit the spoiler to the shield (in the order given above) and secure it using bolts (3), (8) and (7), after first positioning the sheet metal nuts.

Check that all the clips are correctly in place (see page 3).

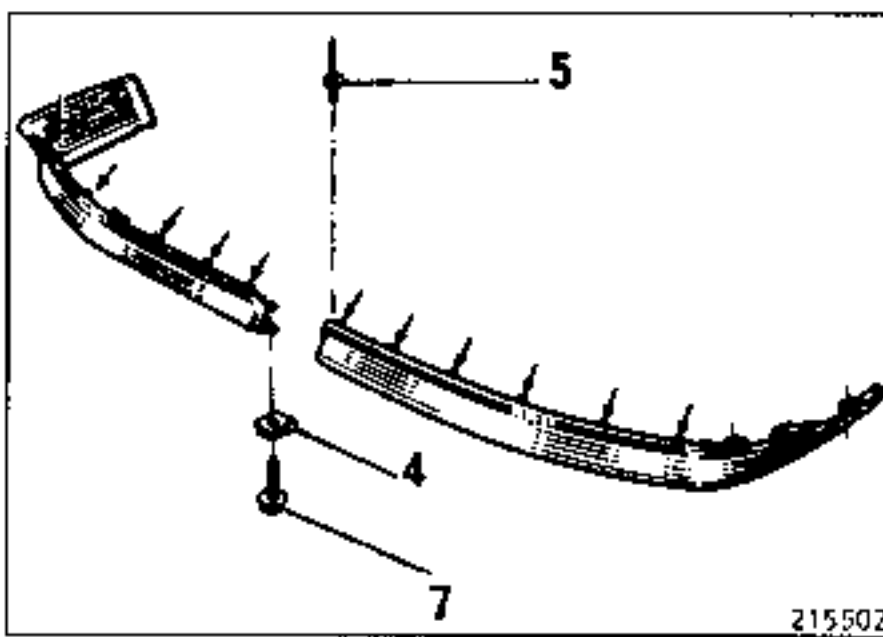

The difference in respect to the first version is the base nut (1), which requires the position of the components to be determined by fitting the base screws (1) in their locations.

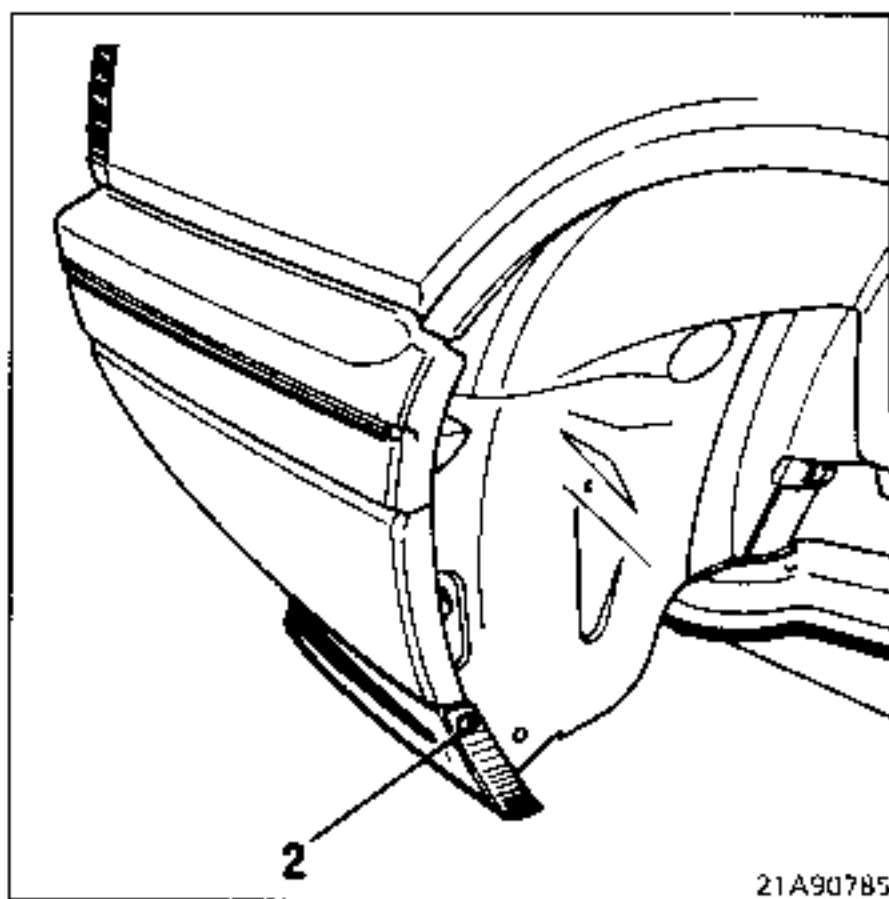
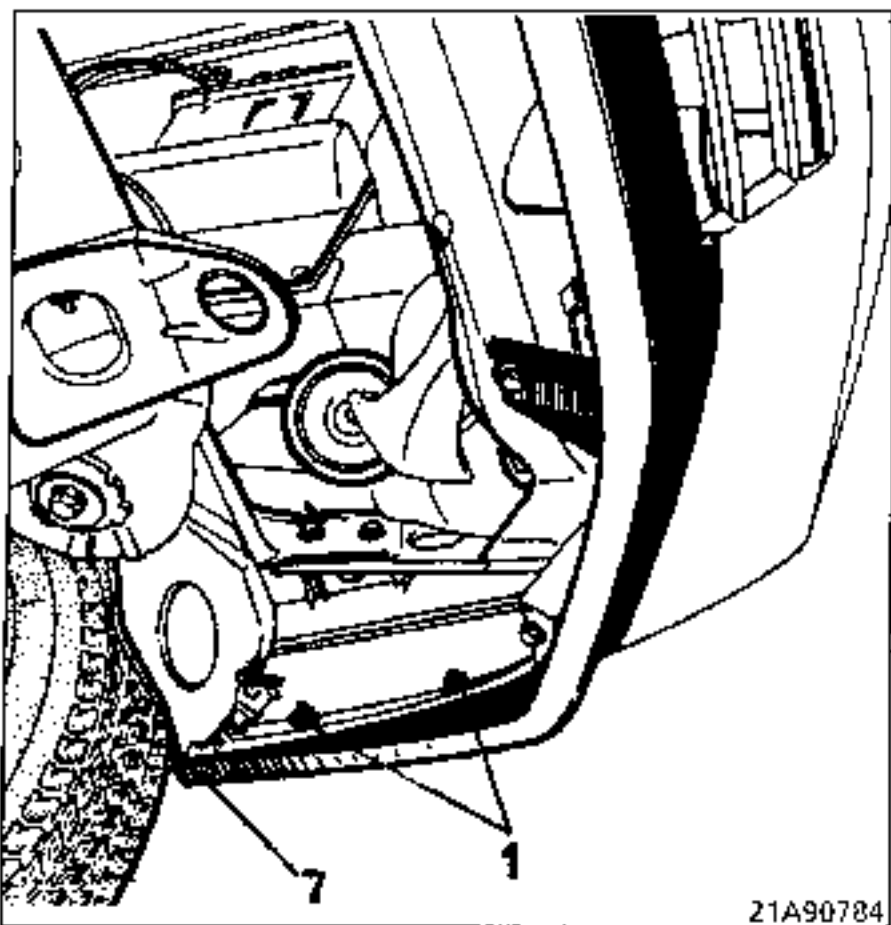

1st and 2nd versions

IMPORTANT : It is essential to make sure that the clips are correctly positioned in their locations.

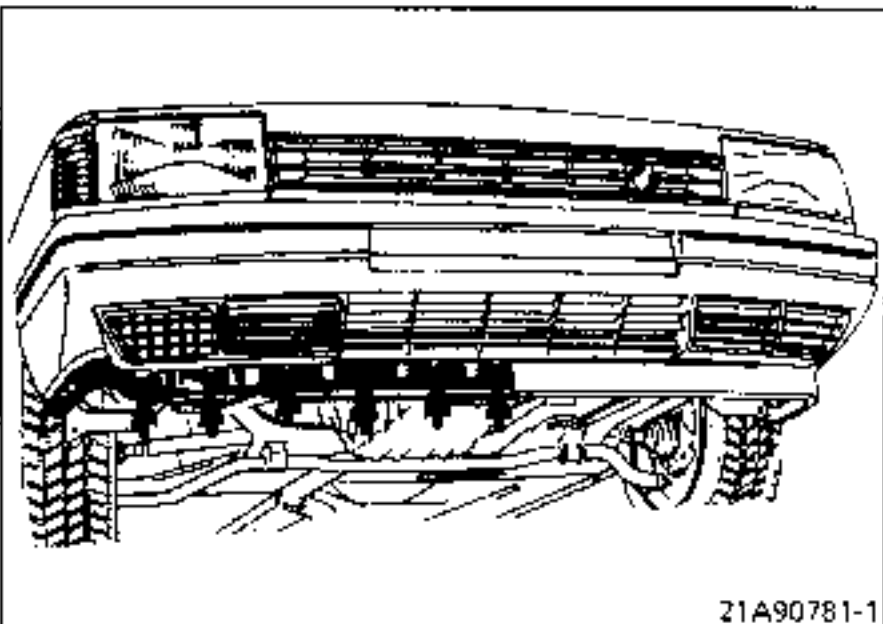

Secure the ends of the spoiler using mountings (2).

NOTE : Mountings (2) may be replaced by bolts (7) and their sheet metal nuts (6).

FITTING

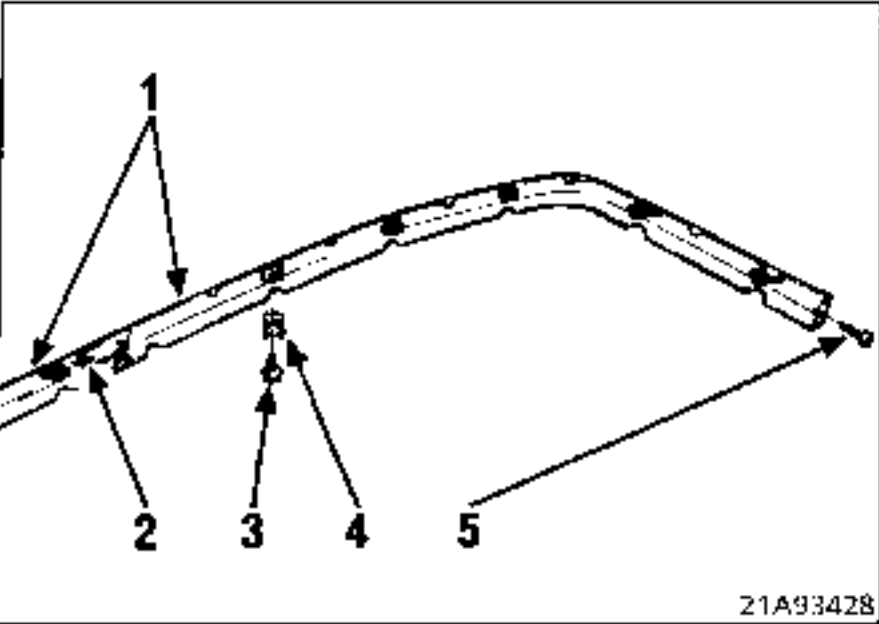

The kit consists of :

- 1 left-hand and right-hand side spoiler component
- 2 3 rivets
- 3 12 bolts
- 4 12 sheet metal nuts
- 5 2 sheet metal screws

Assemble the two left-hand and right-hand sides of the spoiler and secure them using rivets (2).

fit the sheet metal nuts (3) in place on the spoiler.

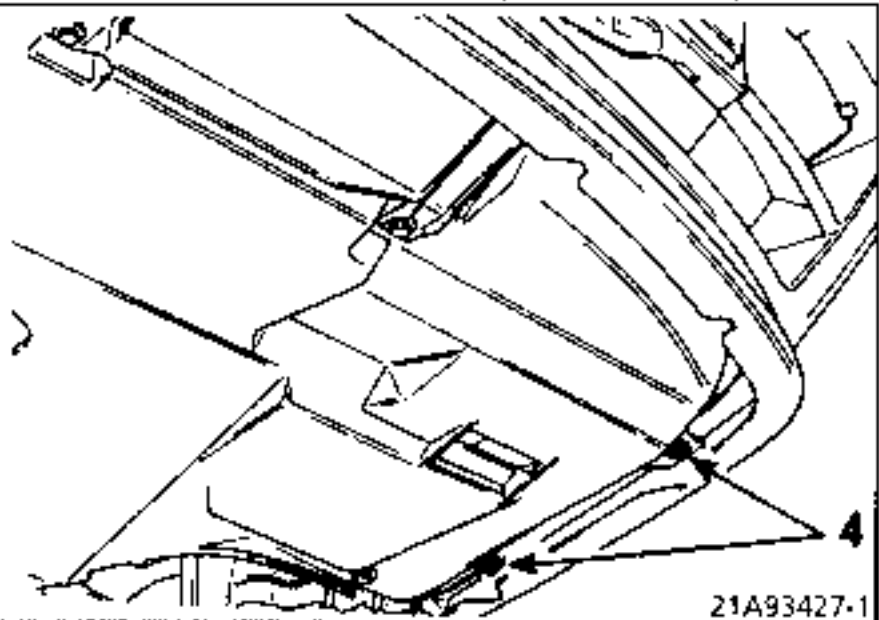

Fit the spoiler to the vehicle.

Check that the undertray is correctly positioned below the engine.

Secure the spoiler using the 12 bolts (4).

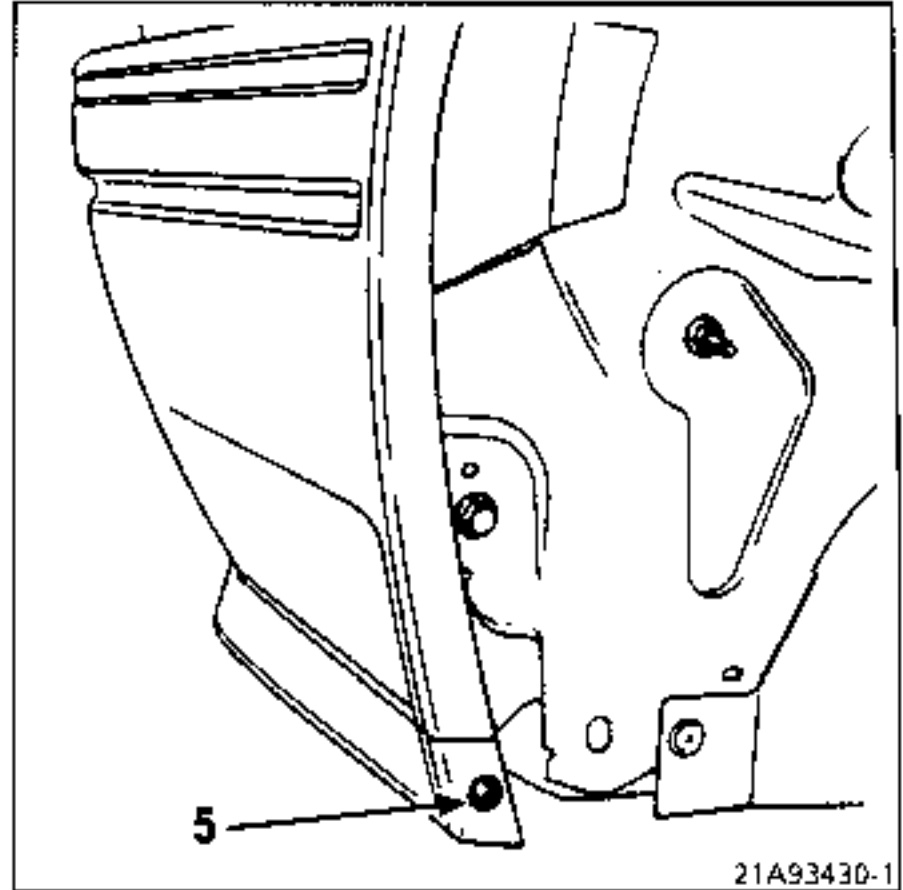

Secure the spoiler at the ends using the two screws (5).

ASSEMBLY

Contents of the kits :

Spoiler (Part No : 77 01 465 493).

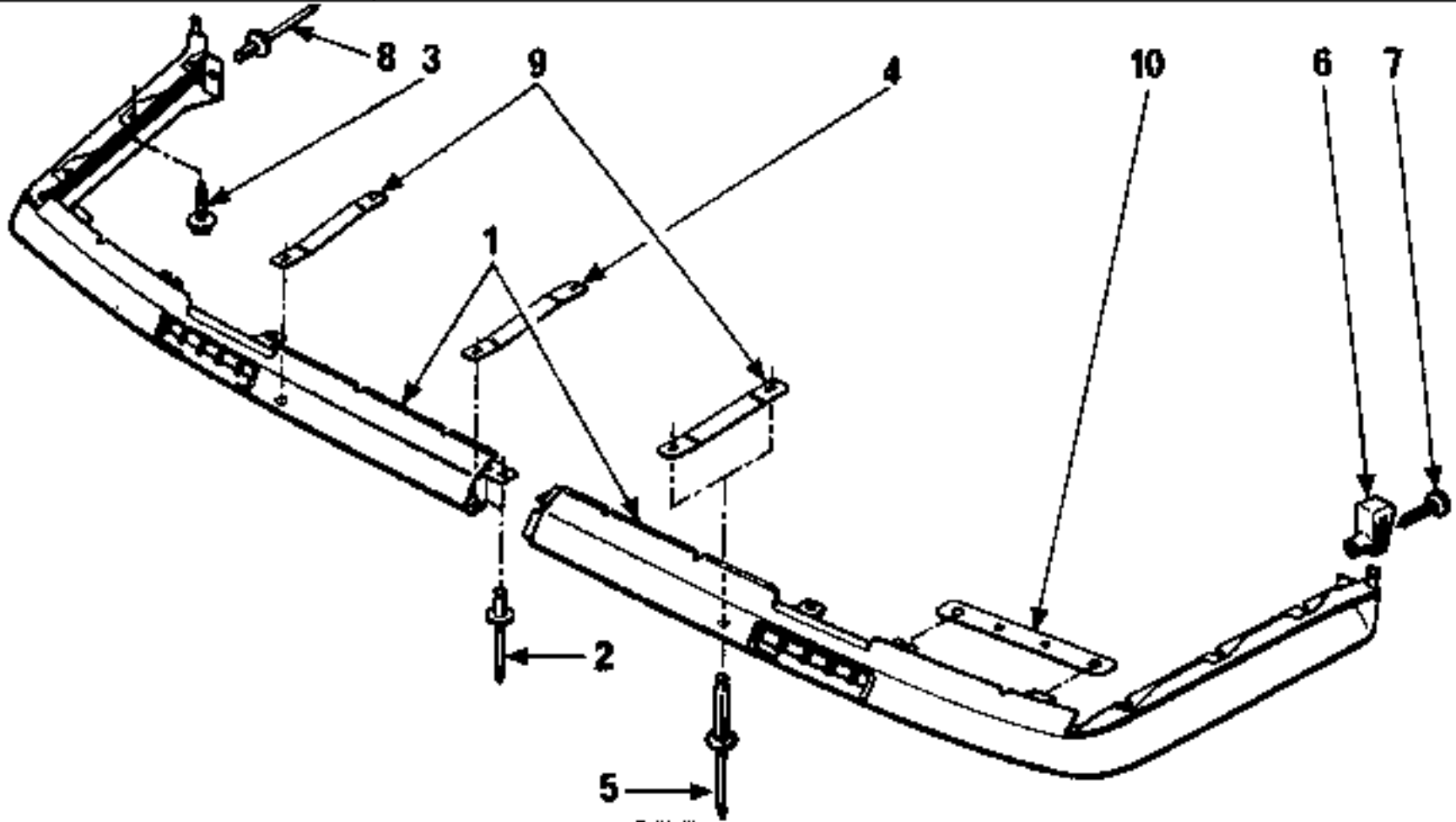

21A91703-1

	Quantity
1 Left-hand and right-hand spoiler components	1 1
2 4.8 mm diameter-12 rivet for assembling the 2 sides of the spoiler	2
3 Captive bolt with washer for securing the spoiler to the shield	16
4 Lug for the connection between the spoiler and lower cross member (black)	1
5 4.8 mm diameter rivet for securing connection lugs	8
6 4.2 mm diameter plastic nut for securing spoiler to shield	2
7 4.2 mm diameter-16 sheet metal screw	2
8 Rivet for securing spoiler to protective shield	2
9 Lugs for connection between spoiler and lower cross member (gold)	2
10 Lug for securing air ducts to spoiler	2

Air ducts :

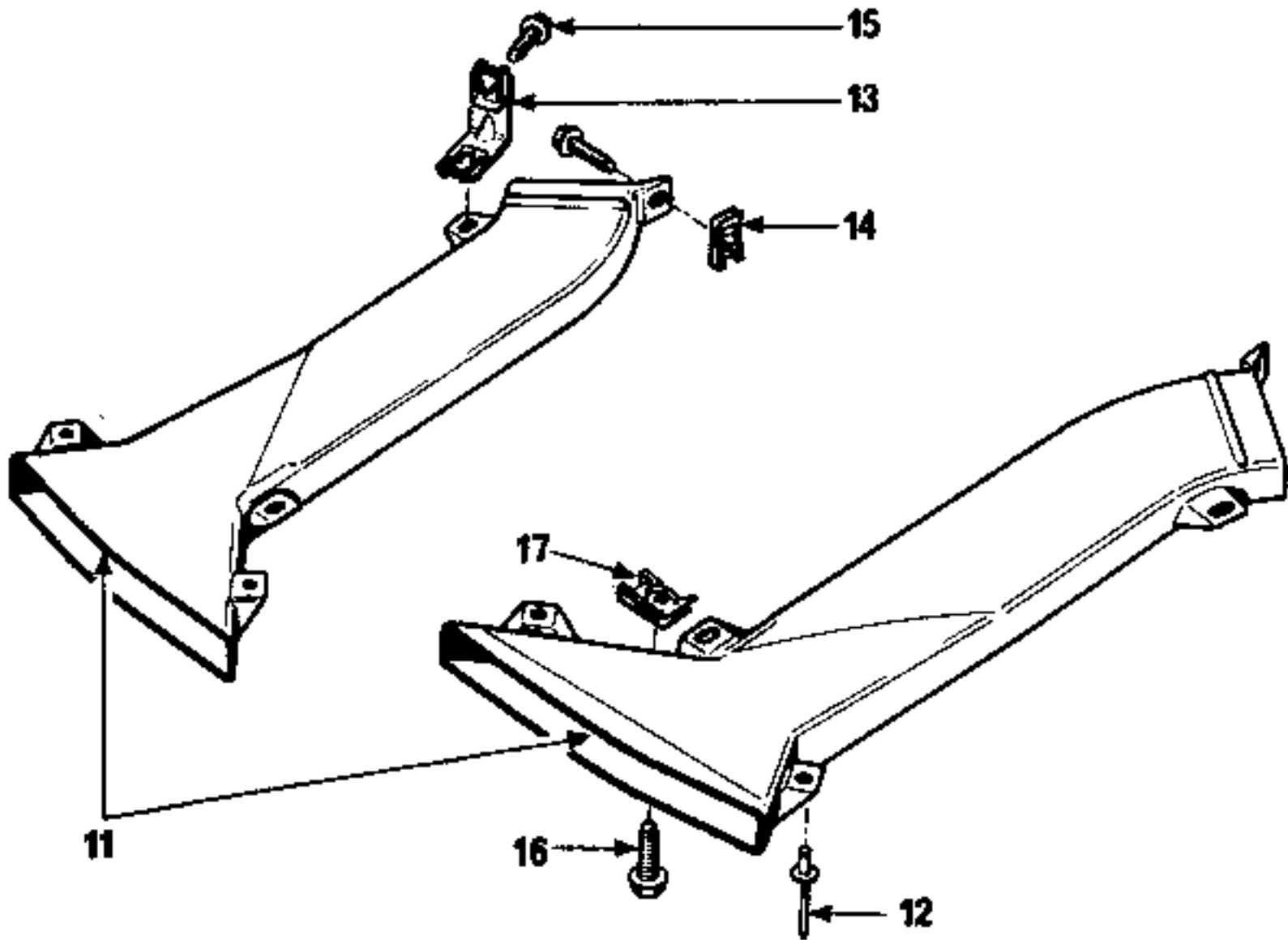

21A92882

	Quantity
11 Right-hand and left-hand side air duct	1 – 1
12 Rivet for mounting duct on spoiler	2
13 Corner piece for connection with protective shield	2
14 M6 sheet metal nut	6
15 M6 base screw	6
16 M8 base screw	2
17 M8 sheet metal nut	2

PREPARING THE PARTS BEFORE ASSEMBLY

Assemble the 2 left-hand and right-hand sides of the spoiler using rivets (2).

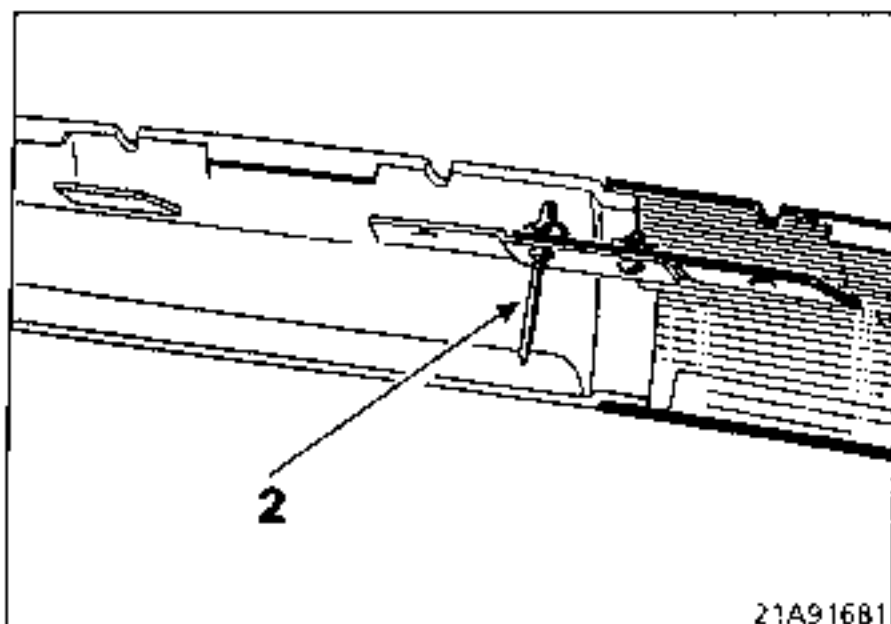

Fit retaining clips (6) at the 2 ends of the spoiler.

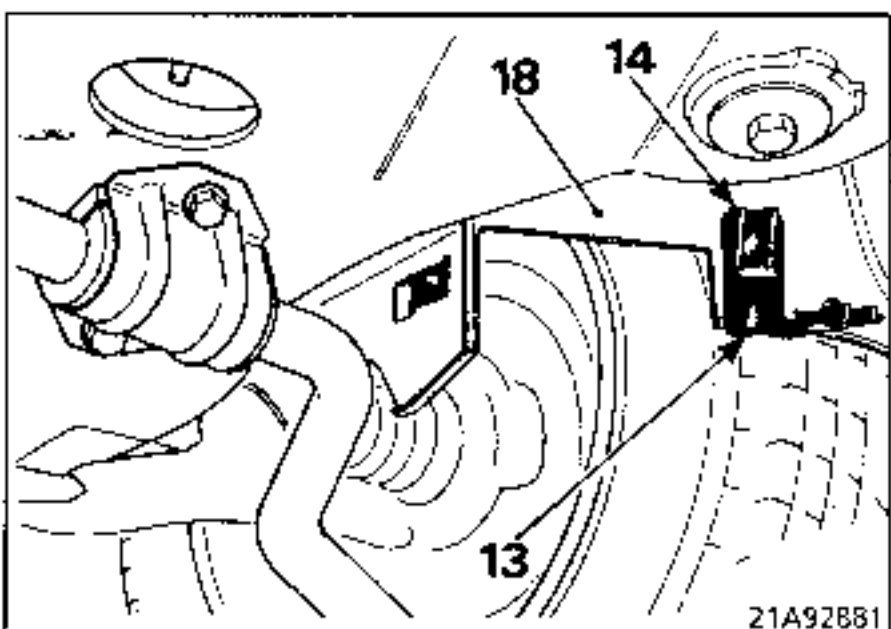
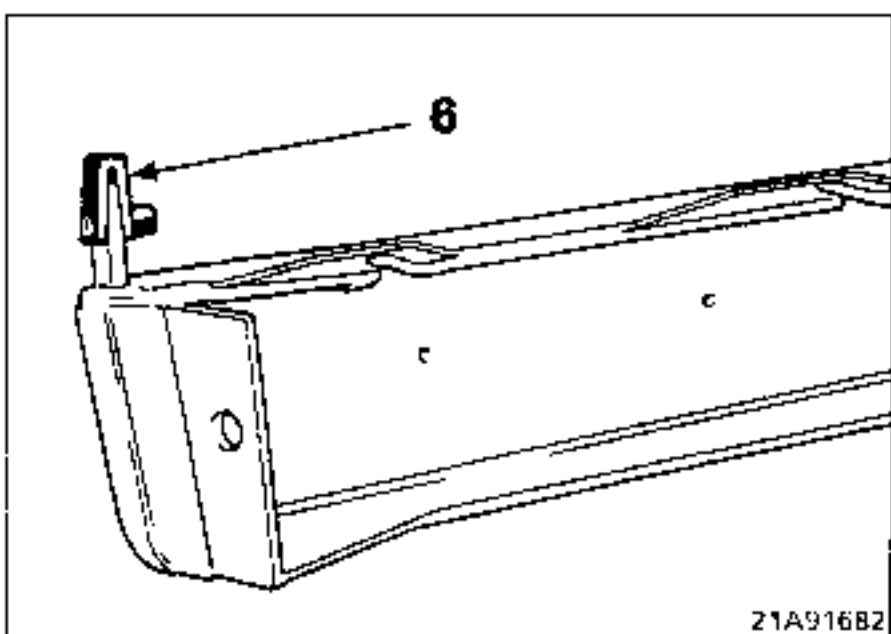

Assemble the sheet metal nuts (14) on the corner pieces (13).

Fit the corner pieces to the 2 protective screens (18).

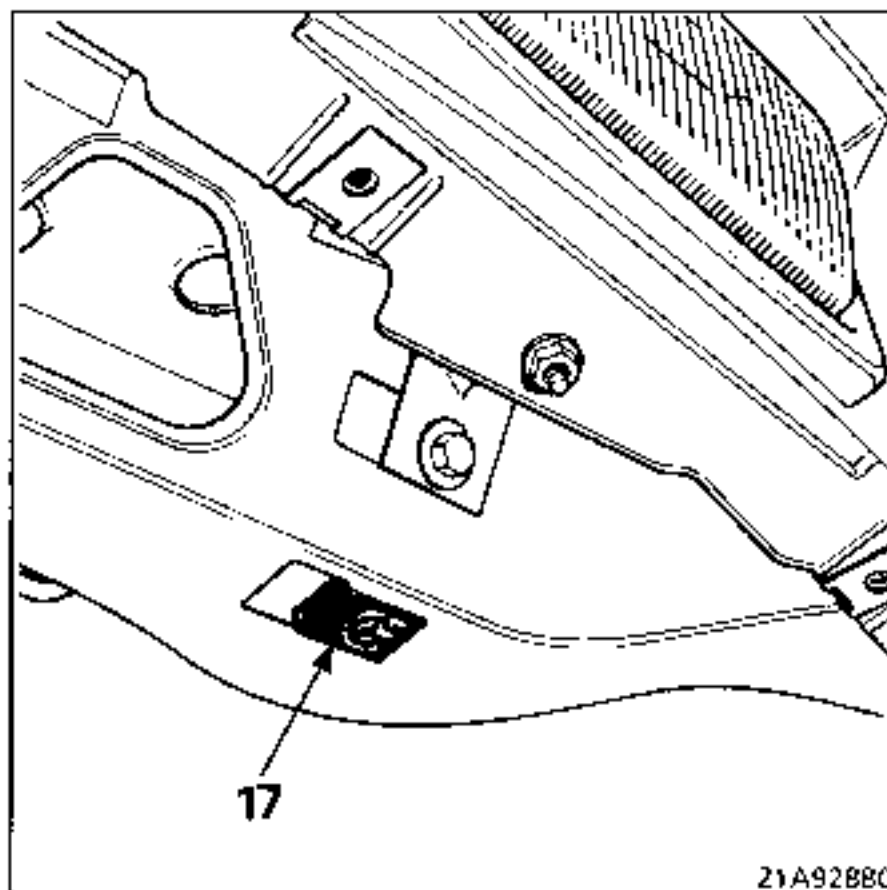

Fit the sheet metal nuts (17) to the front lower cross member

ASSEMBLY

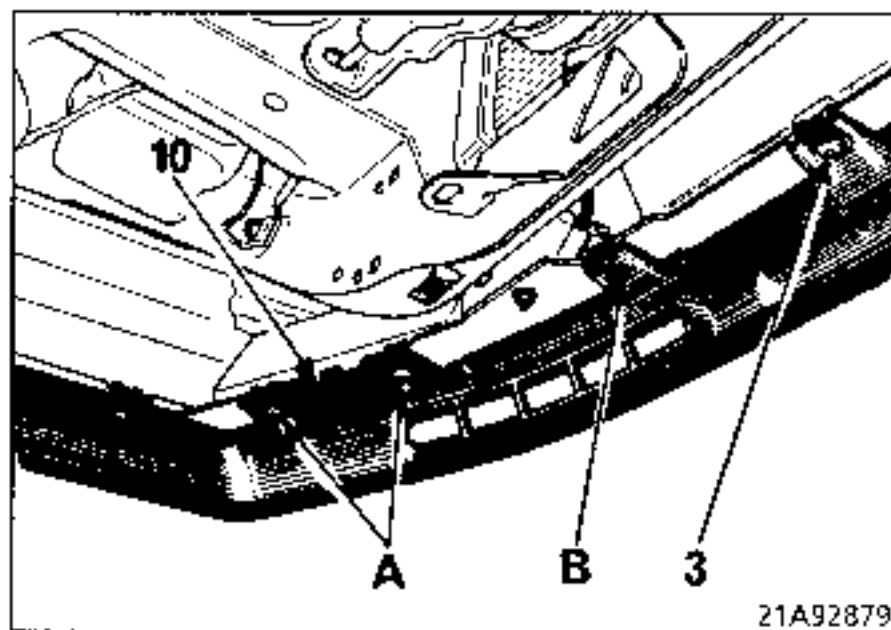

Fit the spoiler to the vehicle and secure it using the captive washer bolt (3).

Place lug (10) at A between the mounting bolts and the spoiler.

Fit the air duct before securing the spoiler at B.

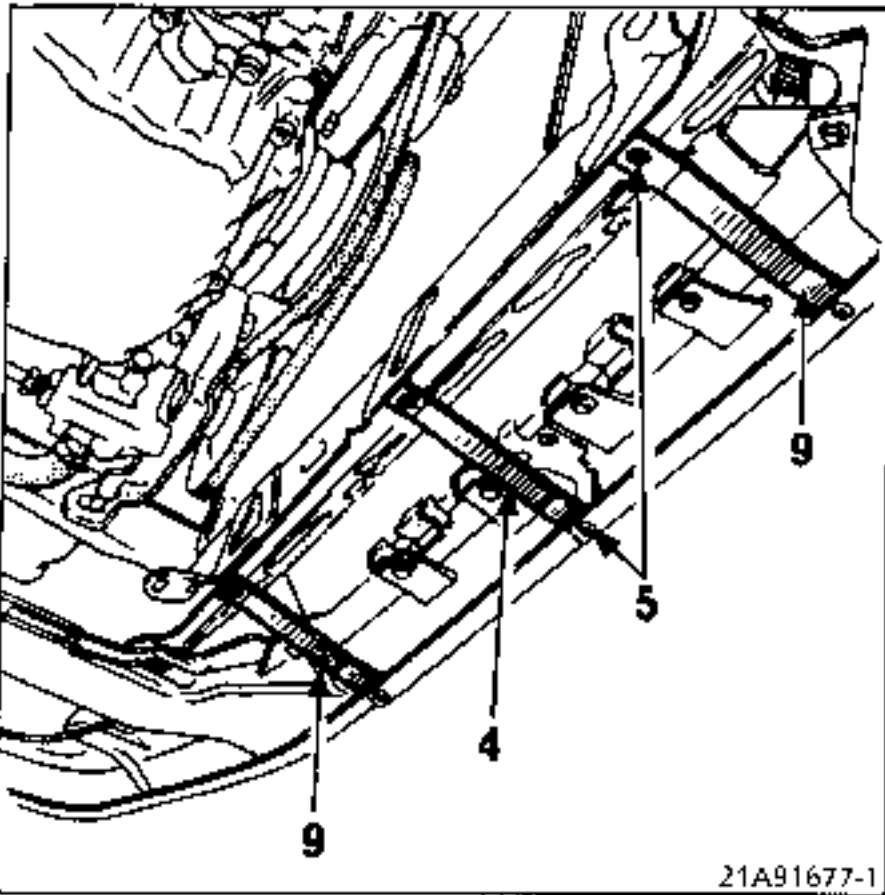

Fit the 3 connecting lugs (4) and (9) connecting the spoiler to the lower cross member by rivets (5).

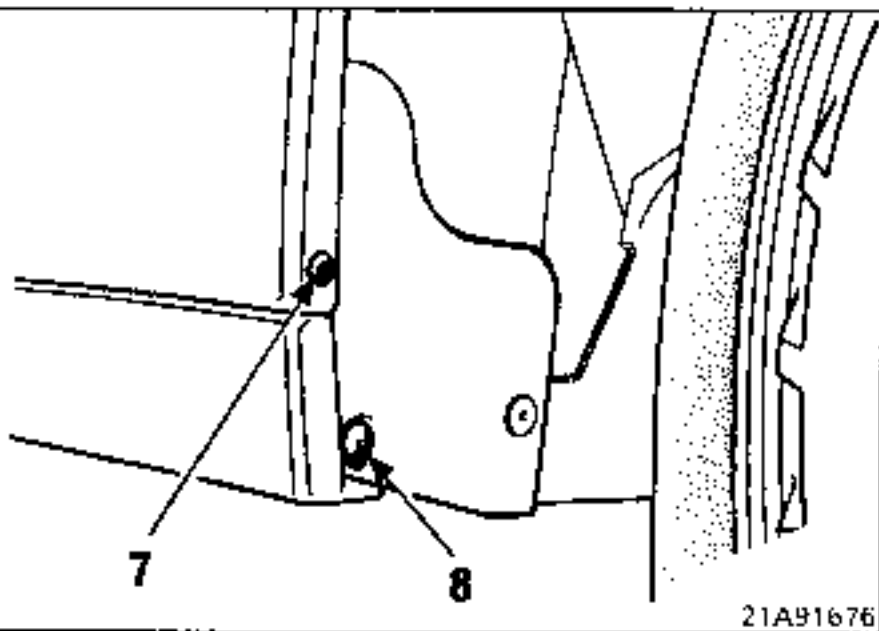

Secure the ends of the spoiler using sheet metal screws (7) and rivets (8).

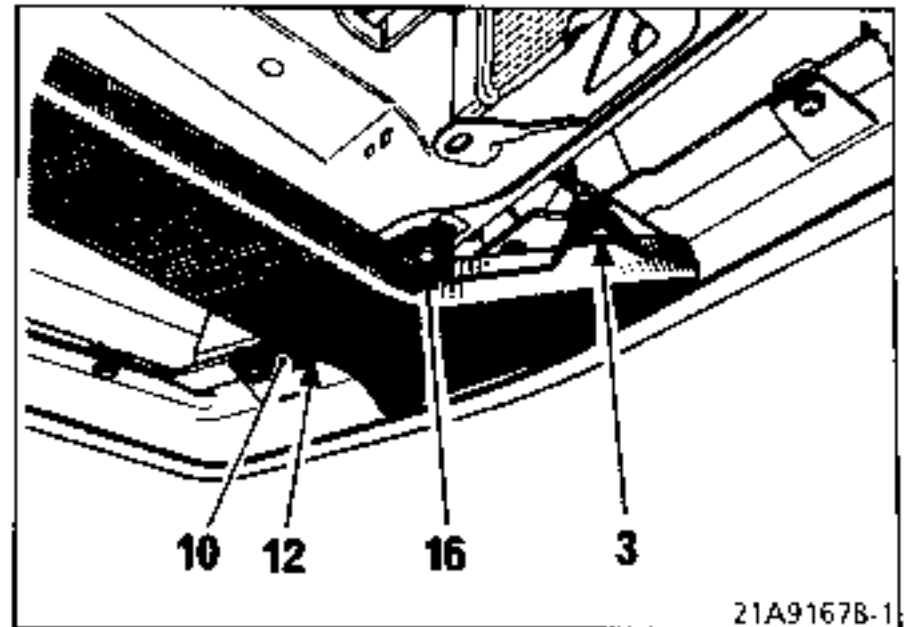

Offer up the air ducts and secure them using rivets (12) on lugs (10), screws (16) on the lower cross member and screws (3) on the spoiler.

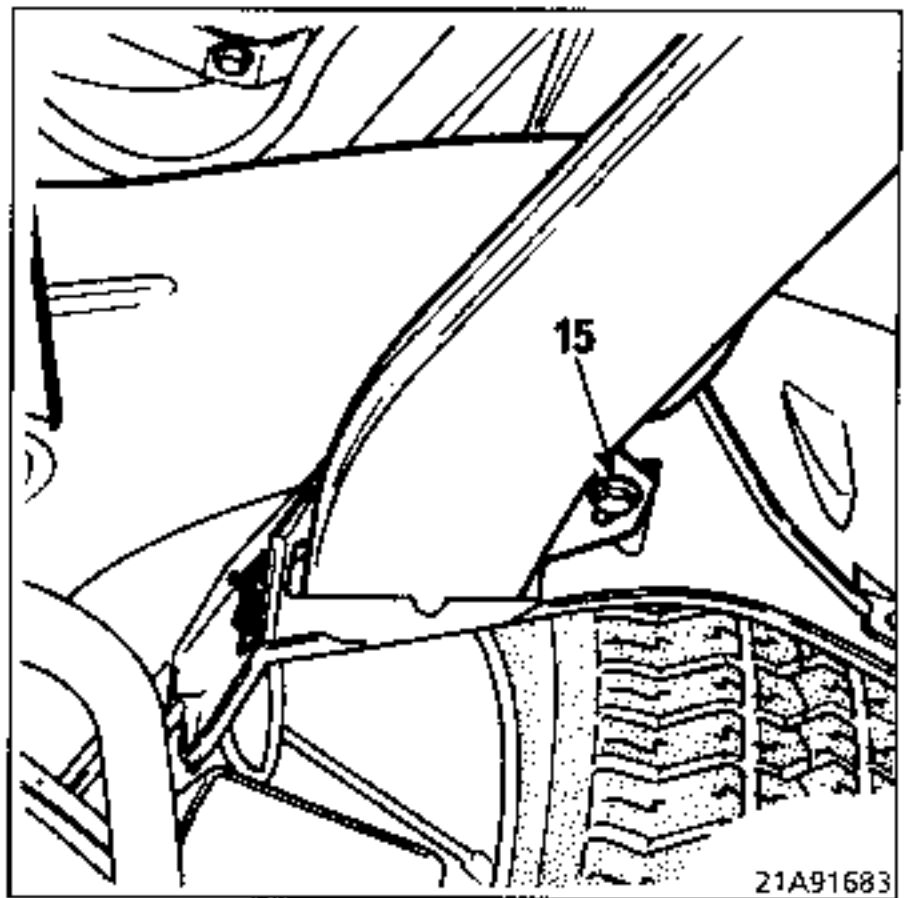

Secure the rear part to the protective shield using bolts (15).

FITTING THE GRILLE AND AIR INTAKE CASING

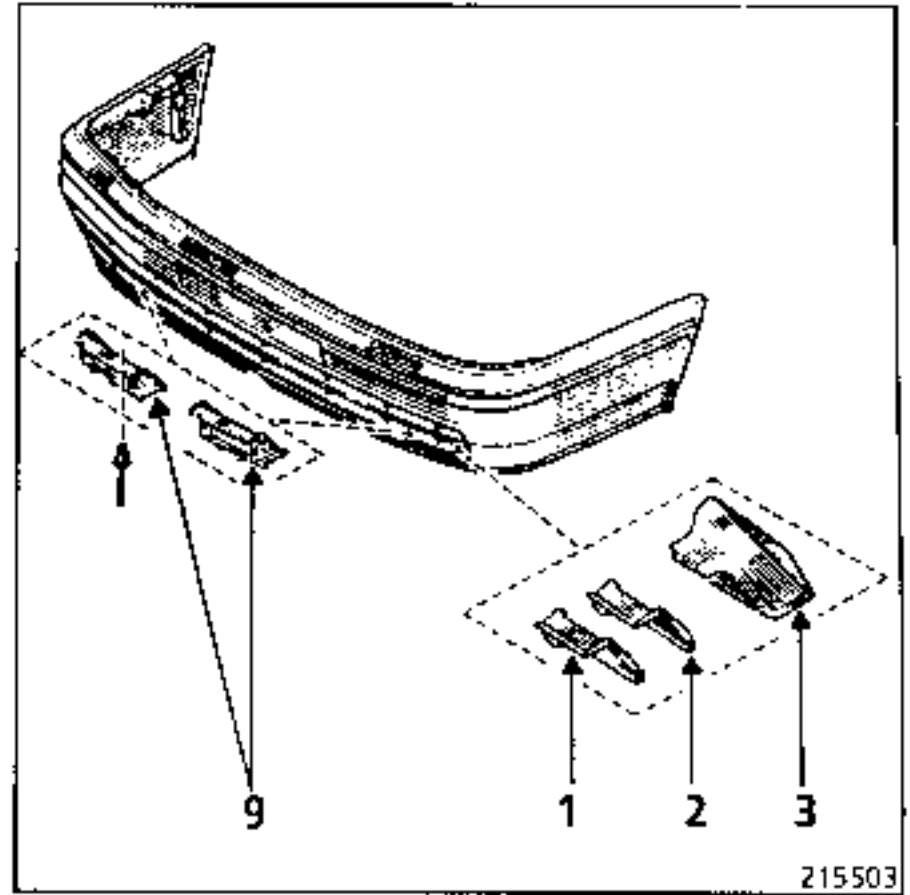
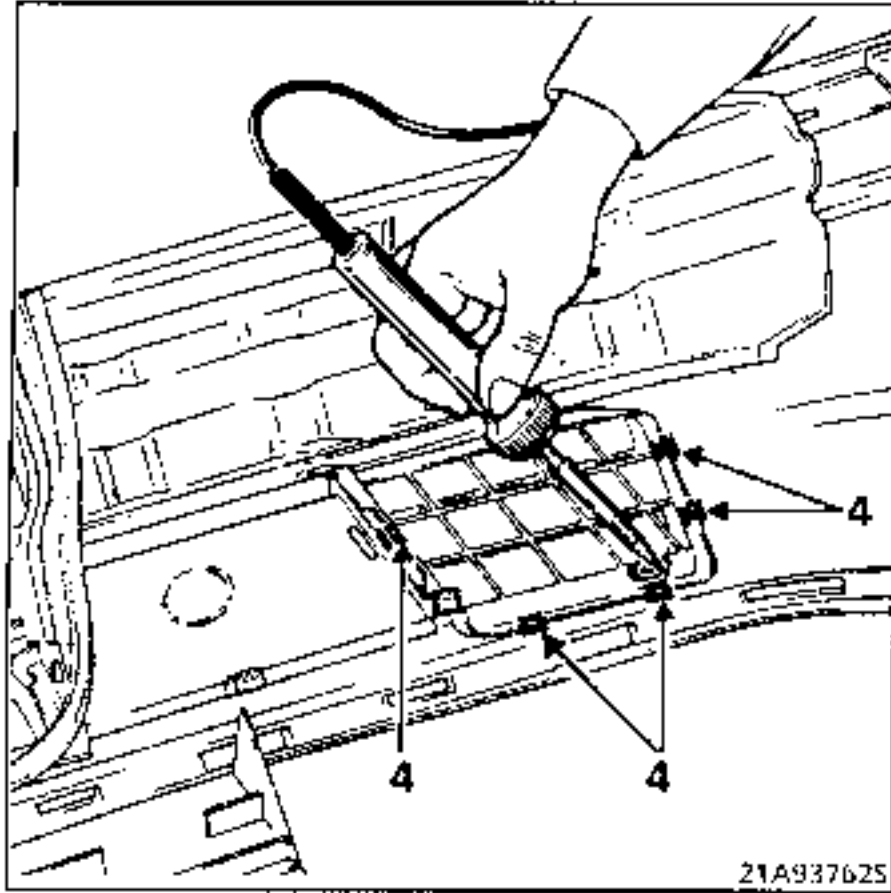

Fit the 5 clips (4) (supplied in the kit containing the grille) around the edge of the grille as shown in the drawing.

Then carry out the same operation for the blanking cover to secure the grille.

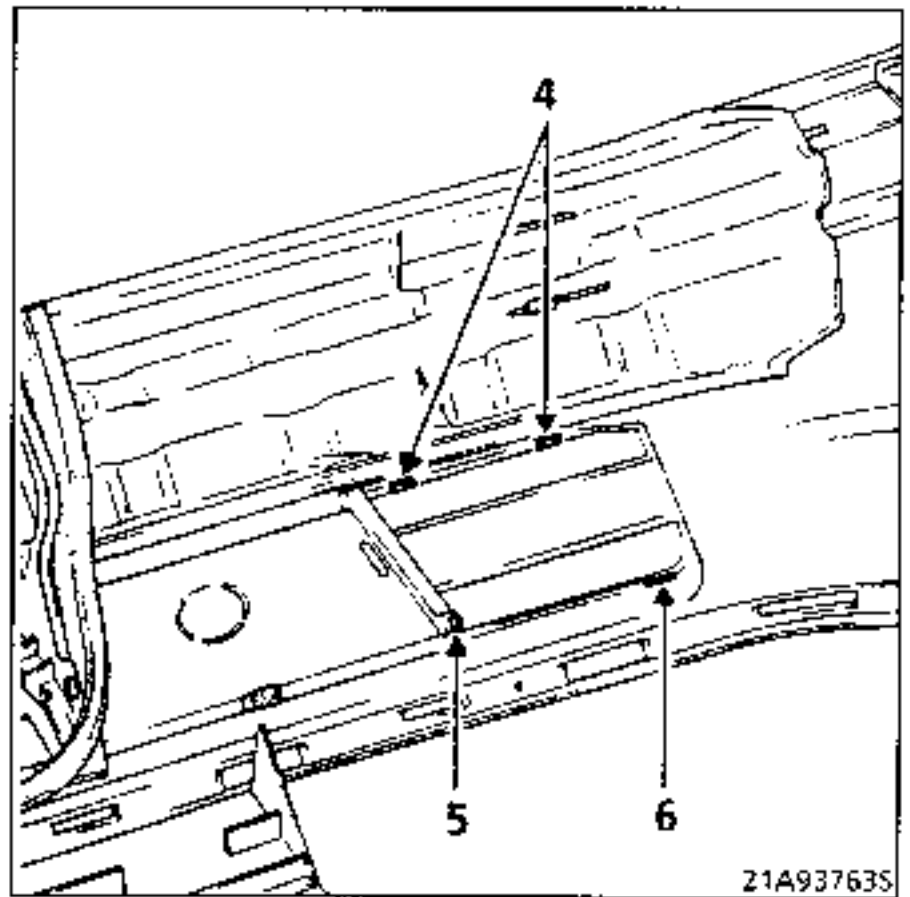
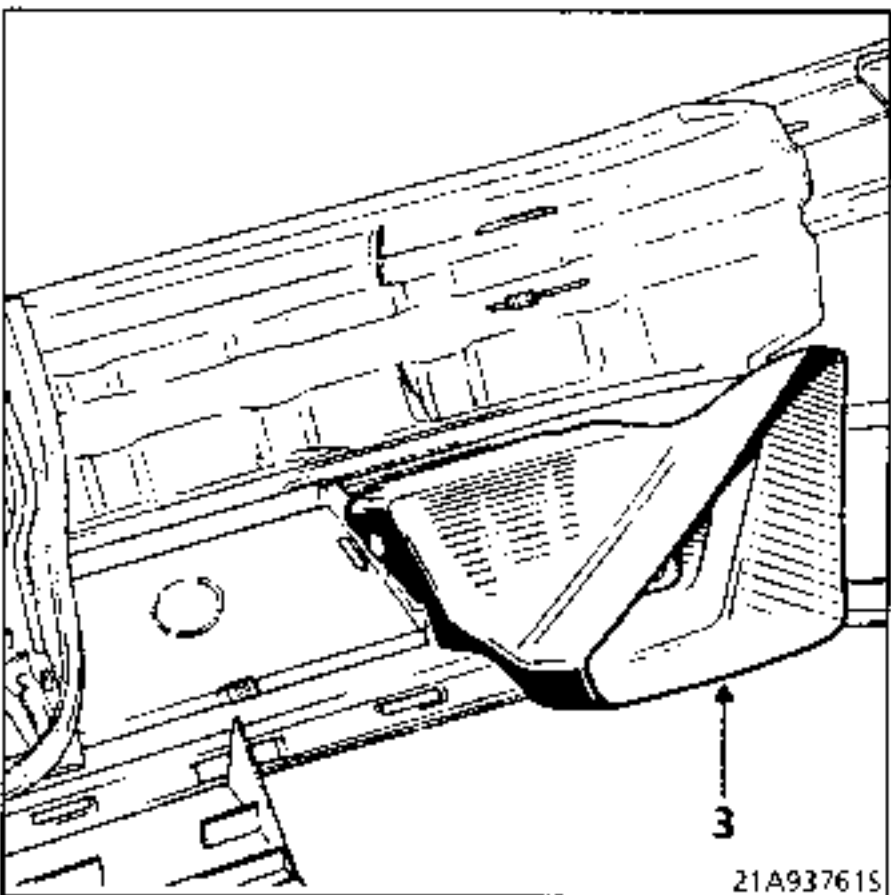

The front bumper supplied by the Parts Department comes fitted with 2 clips (4) which are used to secure the blanking cover (1) or the grille (2).

To enable these parts to be fitted, the two lugs (5) and (6) are not soldered in place.

Fit the air intake casing (3) over the grille and fit it down onto the clips (4) to secure it in place.

FITTING THE BLANKING COVER

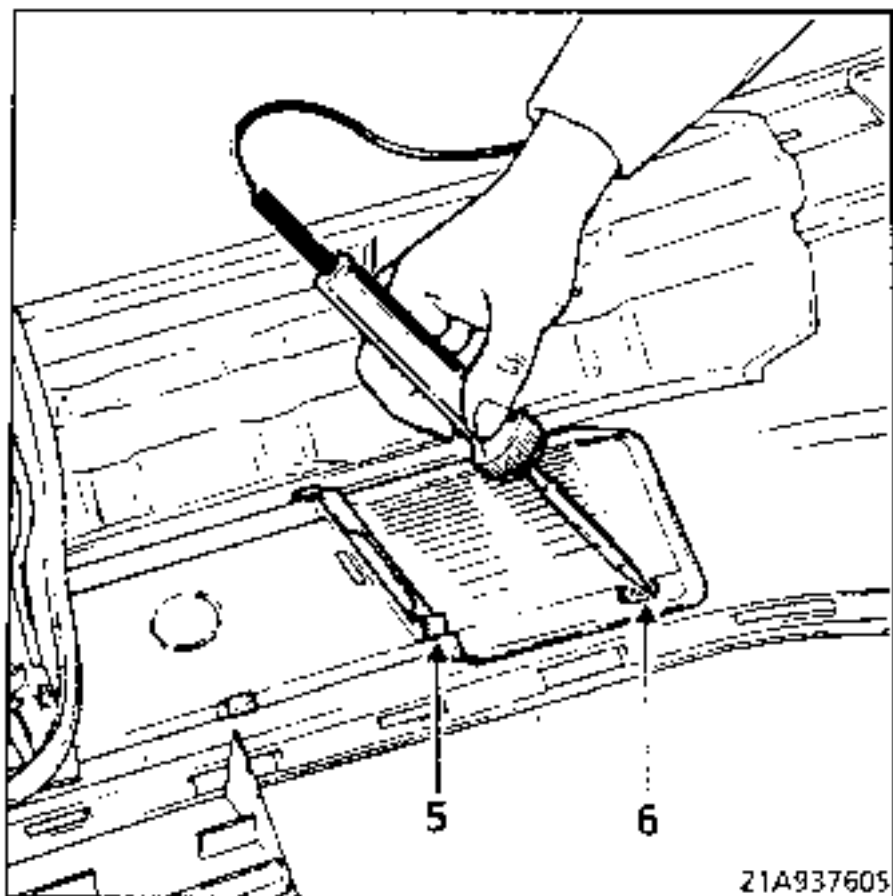

Fit the blanking cover by engaging it in the two clips (4) and on the plastic lugs (5) and (6).

Using a soldering iron which has first been dipped in some grease or wax to prevent the plastic sticking, solder the two lugs (5) and (6).

FITTING BRACKETS FOR ADDITIONAL LIGHTS

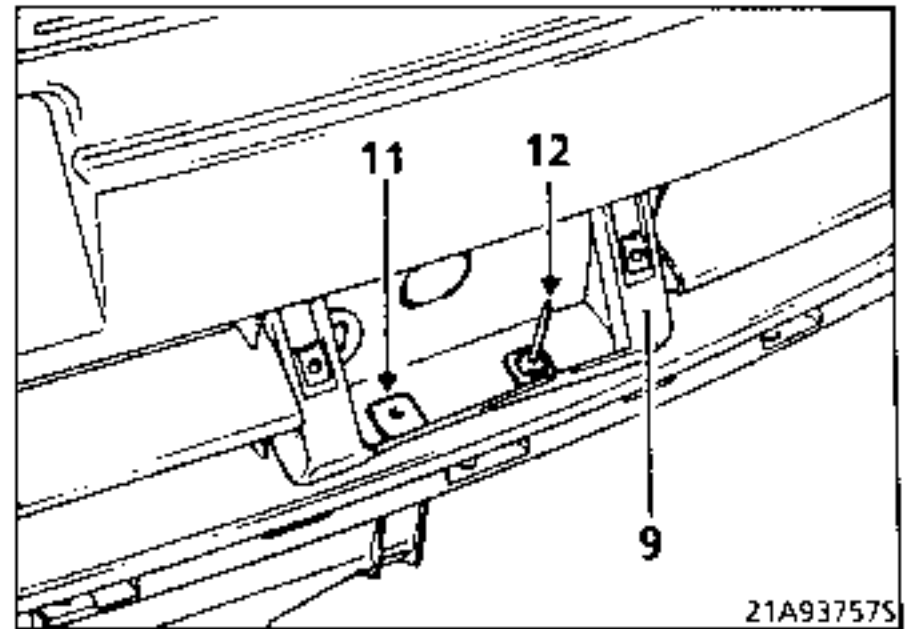
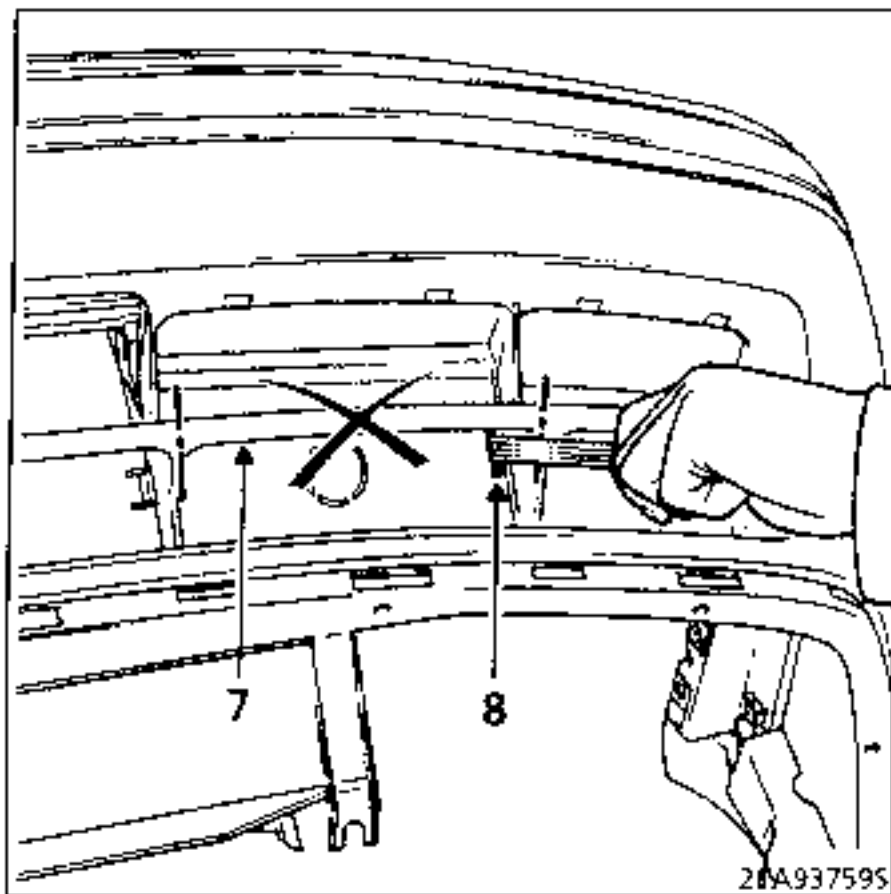

Mark the position of the two lower securing points (11) on the bumper.

Remove the bracket (9) and drill the four securing points to a diameter of 4.5 mm.

Refit the bracket and secure it using 4 rivets (12), Part No : 7 03 072 152.

Using a hacksaw blade, cut the plastic bar (7) making use of the two oblong holes (8) situated at the bottom of the fitting location.

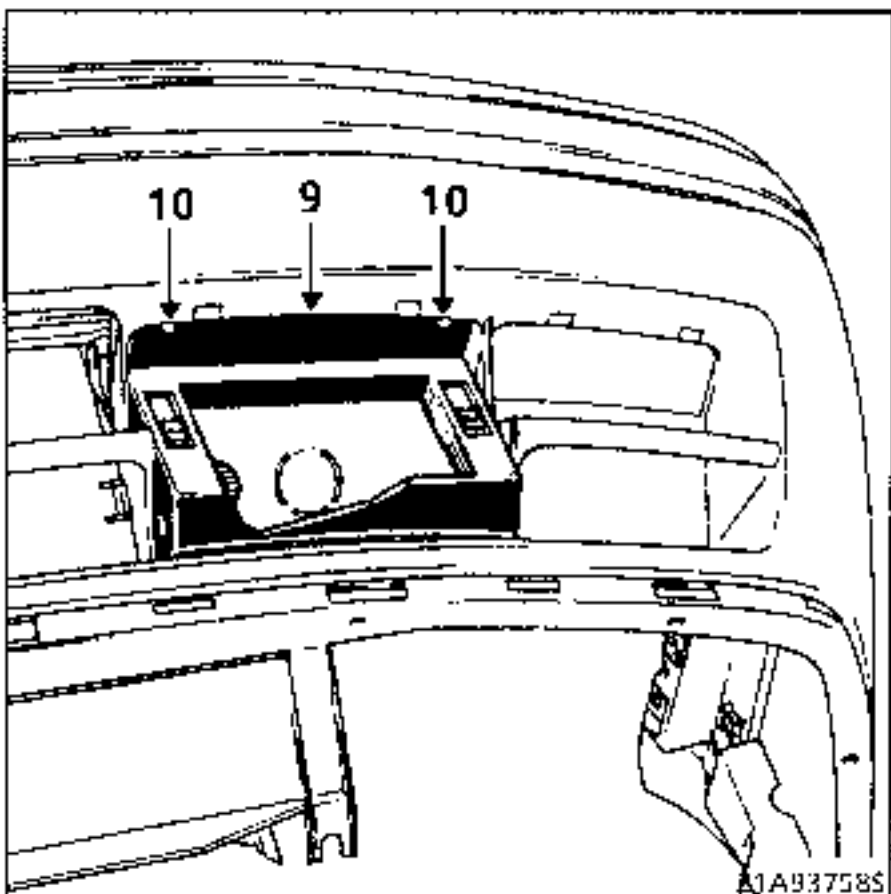

Clip the empty light bracket (9) into its fitting location.

Mark the position of the two upper securing points (10) on the bumper.

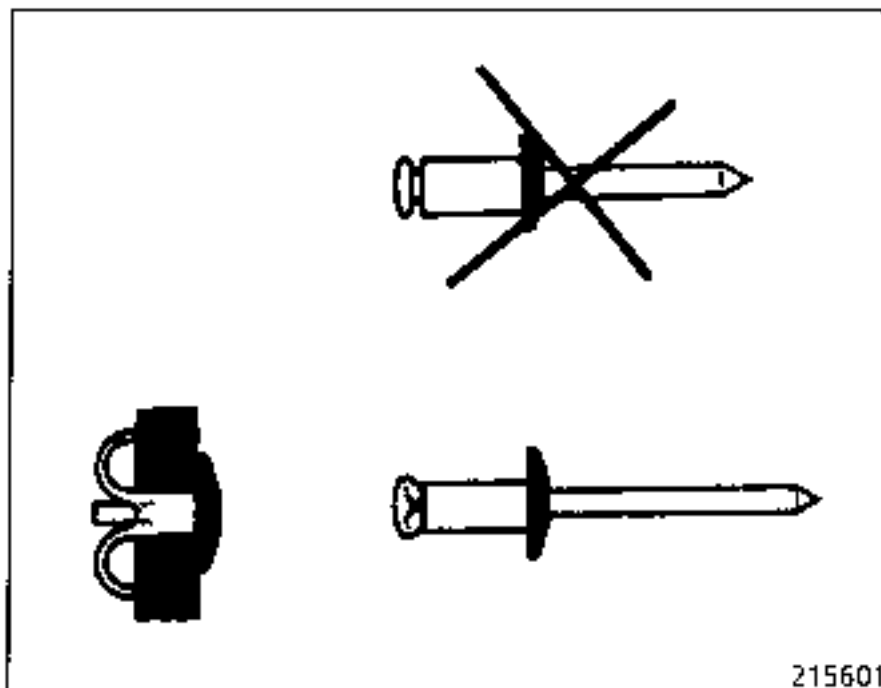

Black anodised rivets (sachet of 83) Diameter
4 mm x Length 10 mm, Part No : 77 01 406 442.

Recommended dimensions : 520 x 110 mm

In view of the mounting material (plastic) and its thickness, use **10 mm rivets of the exploded or fan type which give an excellent hold**, to secure the number plates.

IMPORTANT NOTE : L48 phase 1

When drilling the number plate mounting, all the necessary precautions must be taken to ensure that the drilling depth does not exceed **5 - 10 mm** beyond the thickness of the mounting. This is to prevent damage to the panel of the boot lid (risk of corrosion).

NOTE : L48 phase 2

Renault 21 Phase 2 vehicles are provided with a pre-drilled number plate mounting. Suitable plates must therefore be used - see **NT 147** and **NT 174**.

For drilling dimensions, see Section 4 "Valence".

FITTING

Fit:

- the 8 plastic clips in the upper holes,

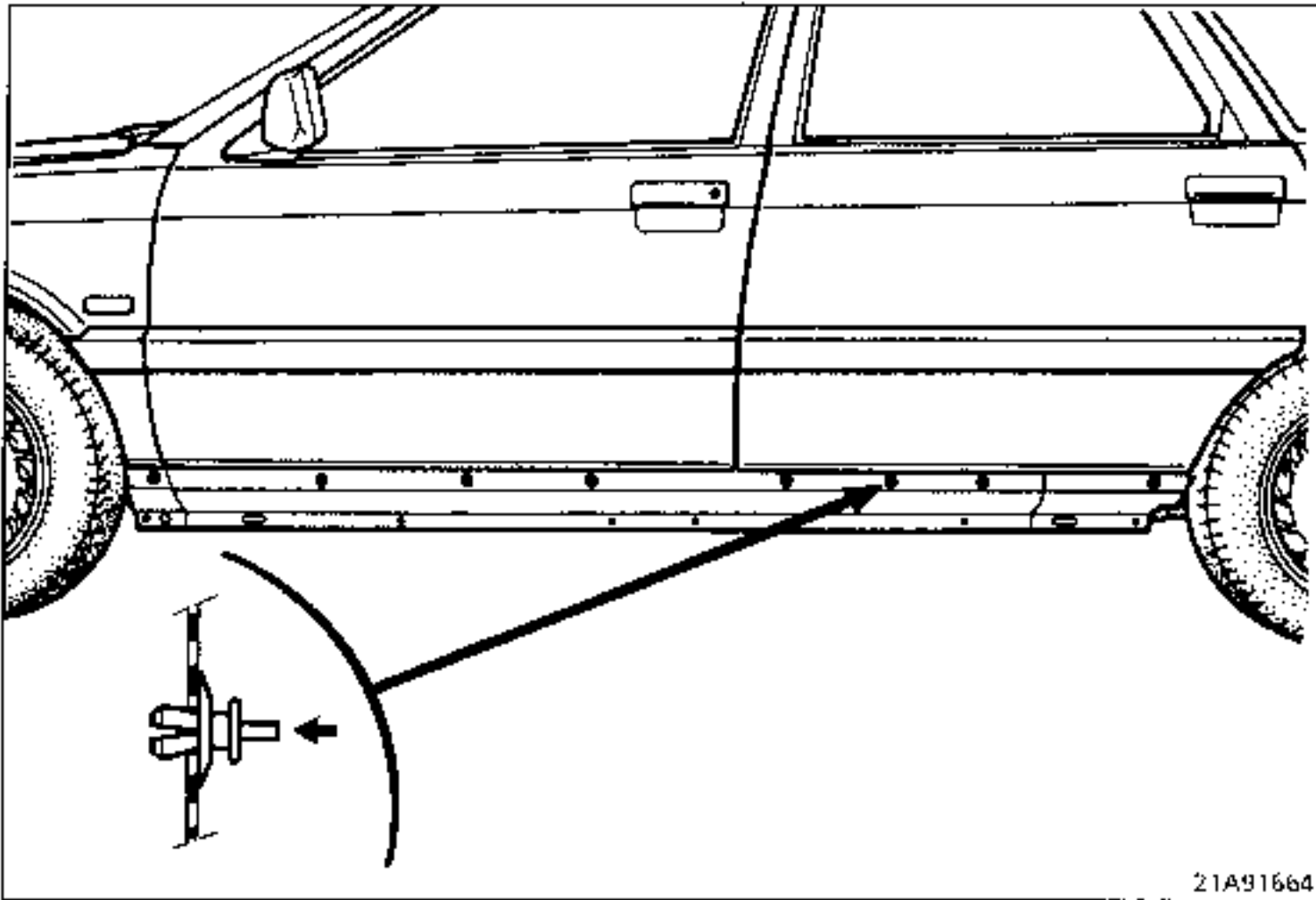

- the skirt, clipping its upper section and pulling it towards the rear of the vehicle.

Secure the sill skirt by clipping its lower section in place.

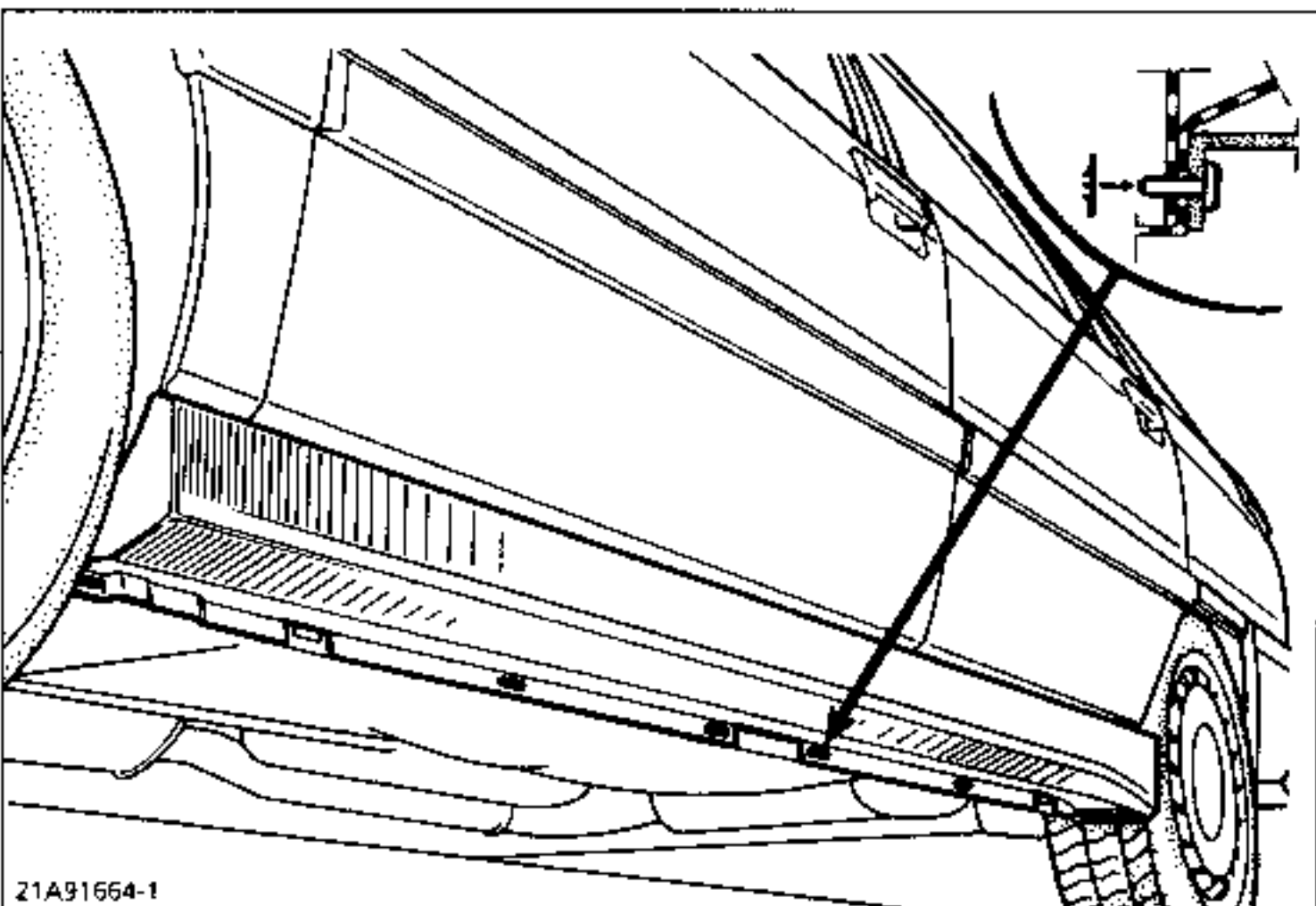

The skirt is removed by unpicking the lower plastic pins and pulling the skirt towards the front of the vehicle.

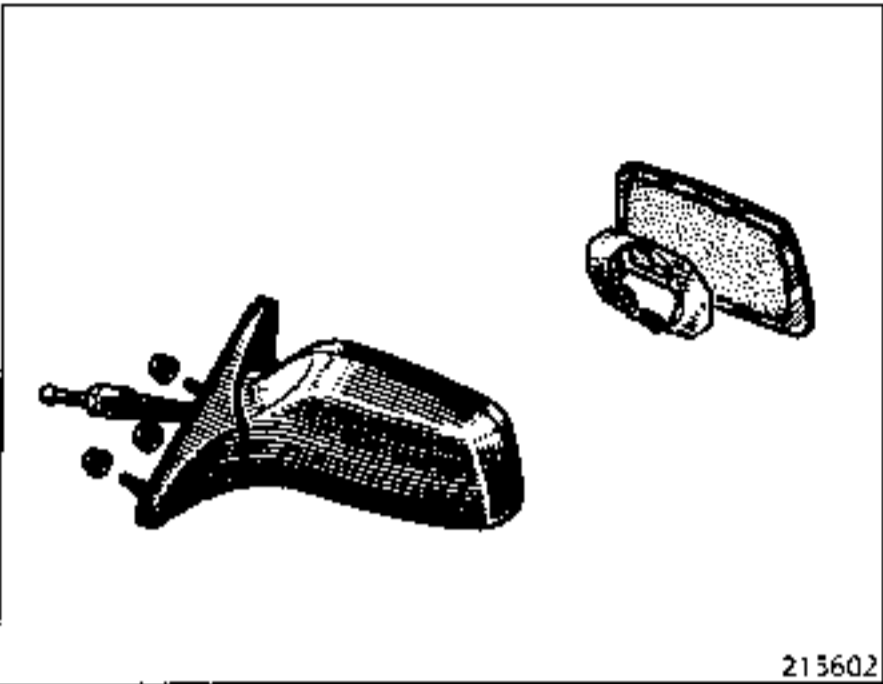

Rear view mirror with manual control.

215602

Rear view mirror with electric control.

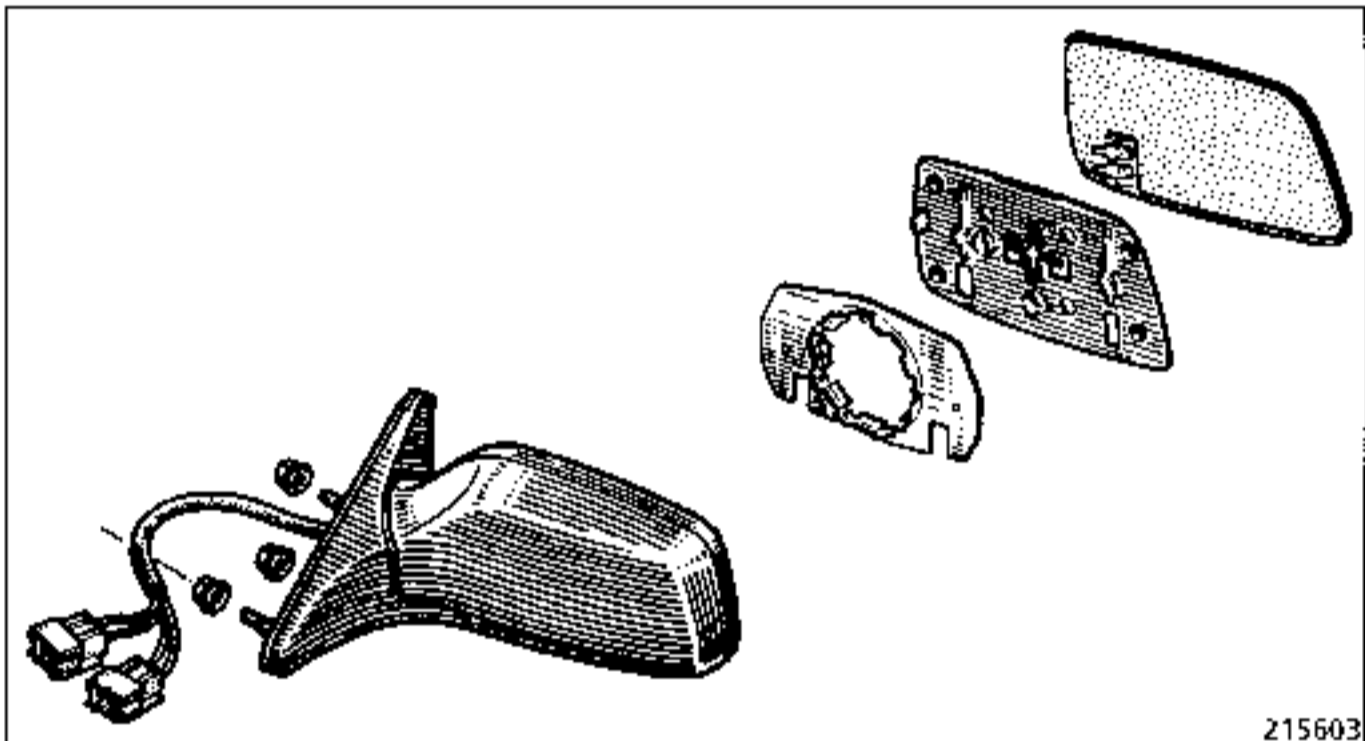

215603

Method for removing a damaged mirror glass.

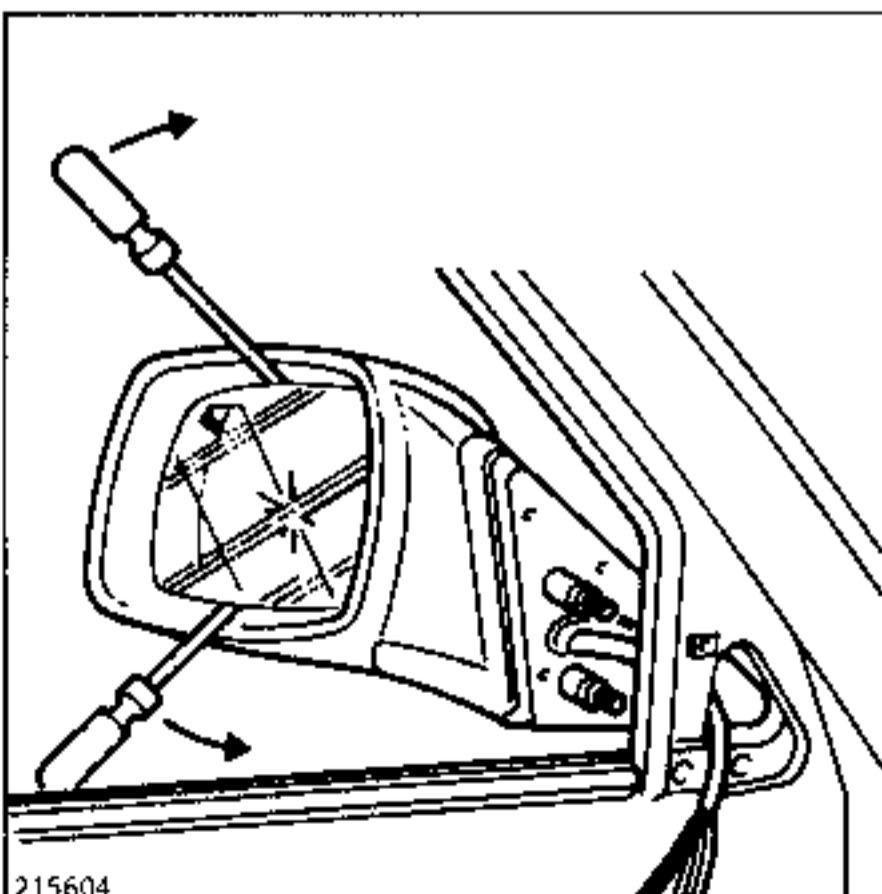

215604

Use a suction pad to remove a mirror which has not been damaged (see section on "Tooling").

REMOVAL

The electric rear view mirror may be dismantled (without removing the trim) after the speaker and its mounting have been removed.

Disconnect the wiring harness and slide it between the trim and the door.

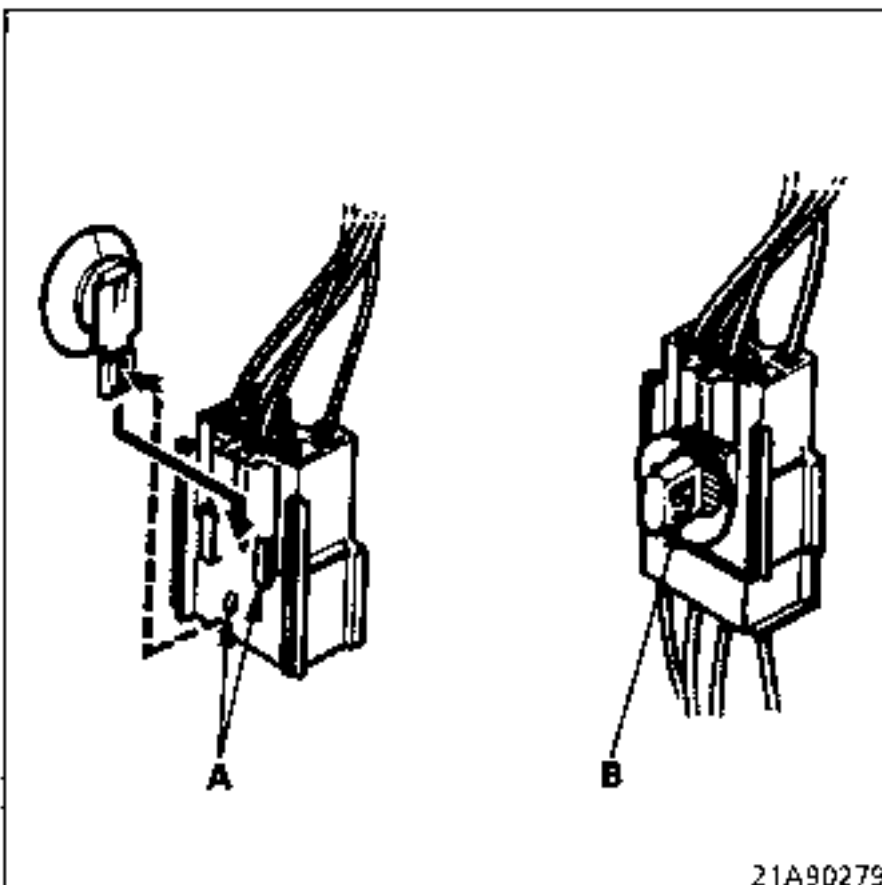
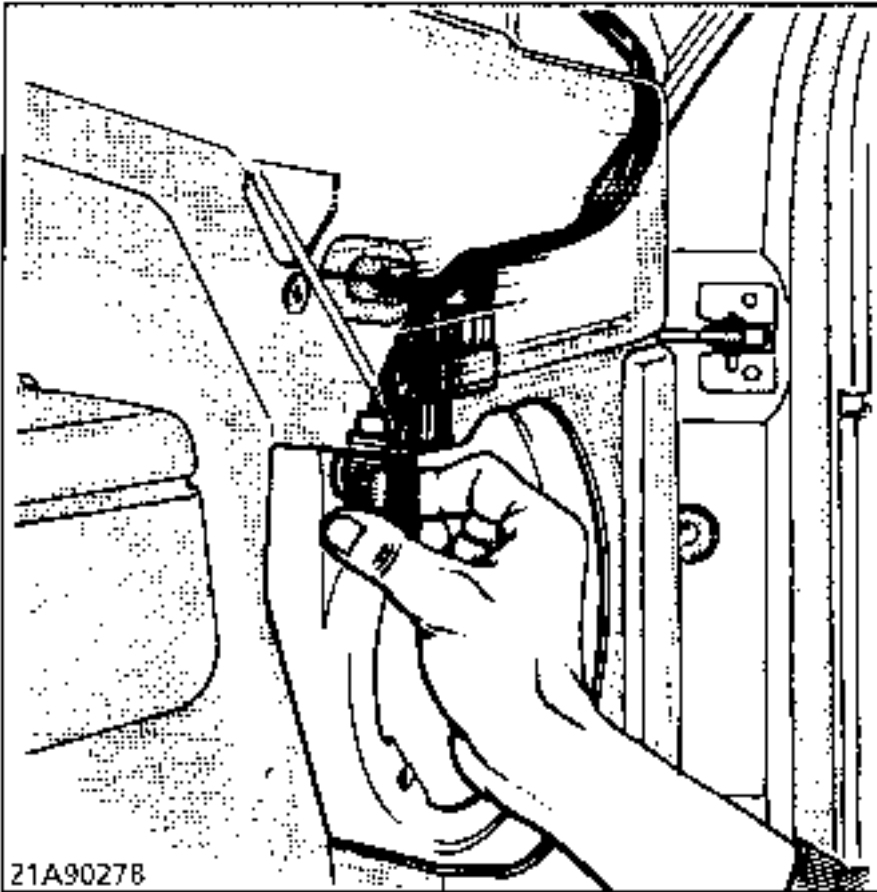

A Female socket mounting on door

B Male socket connecting tab

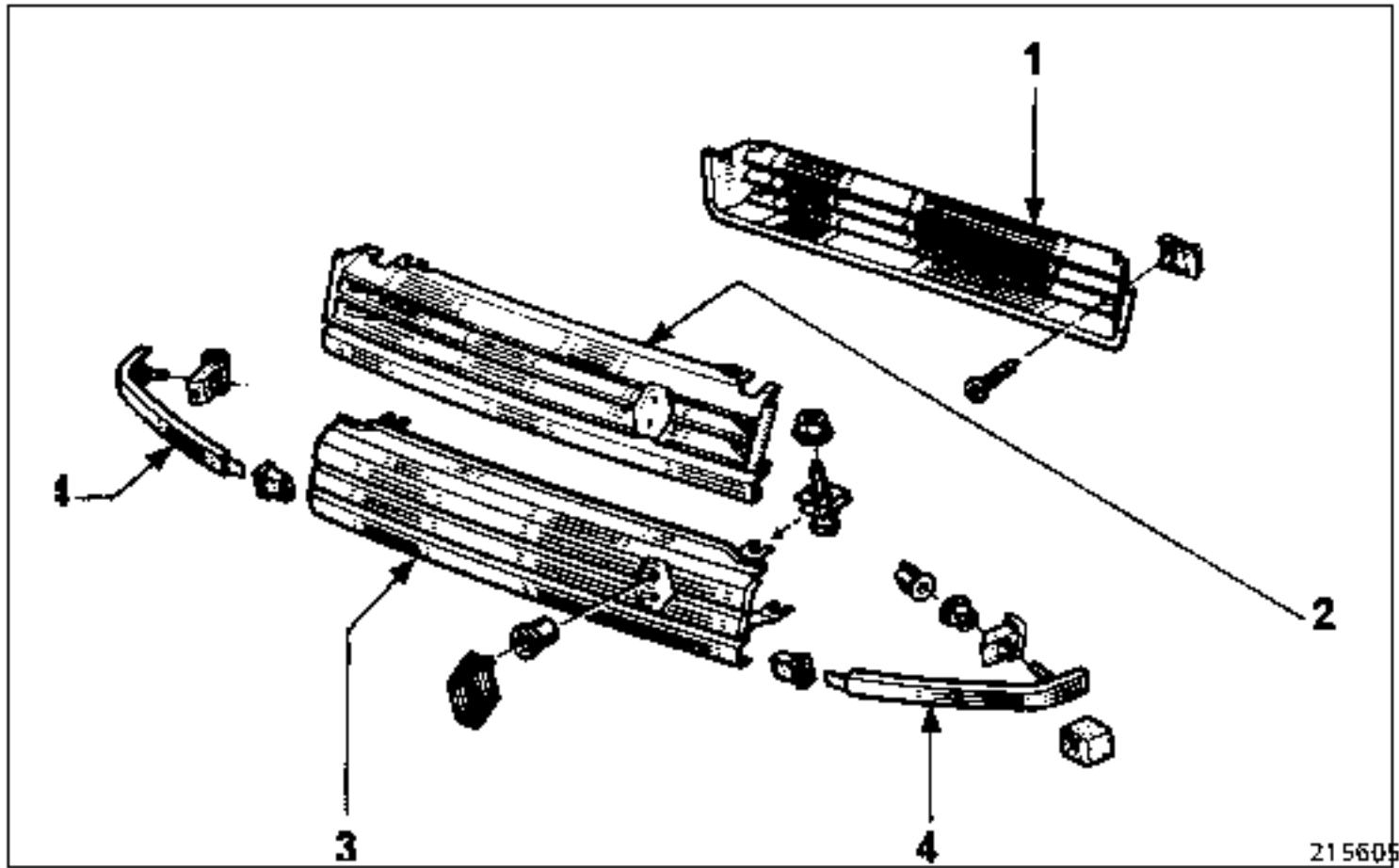

(1) (2) - ABS material

(3) (4) - sheet metal

L485

REMOVAL

Remove the 2 screws (1) and tilt the grille to take it out.

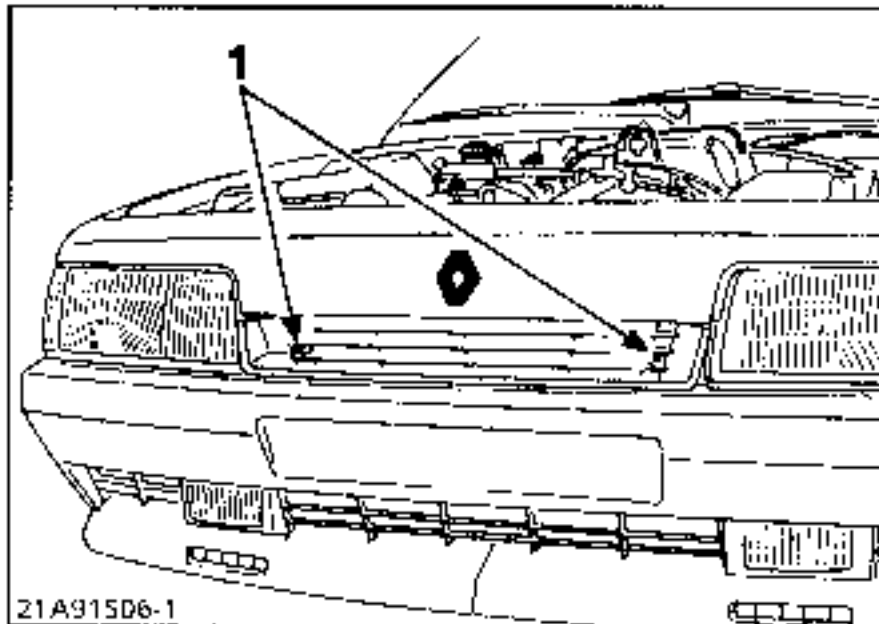

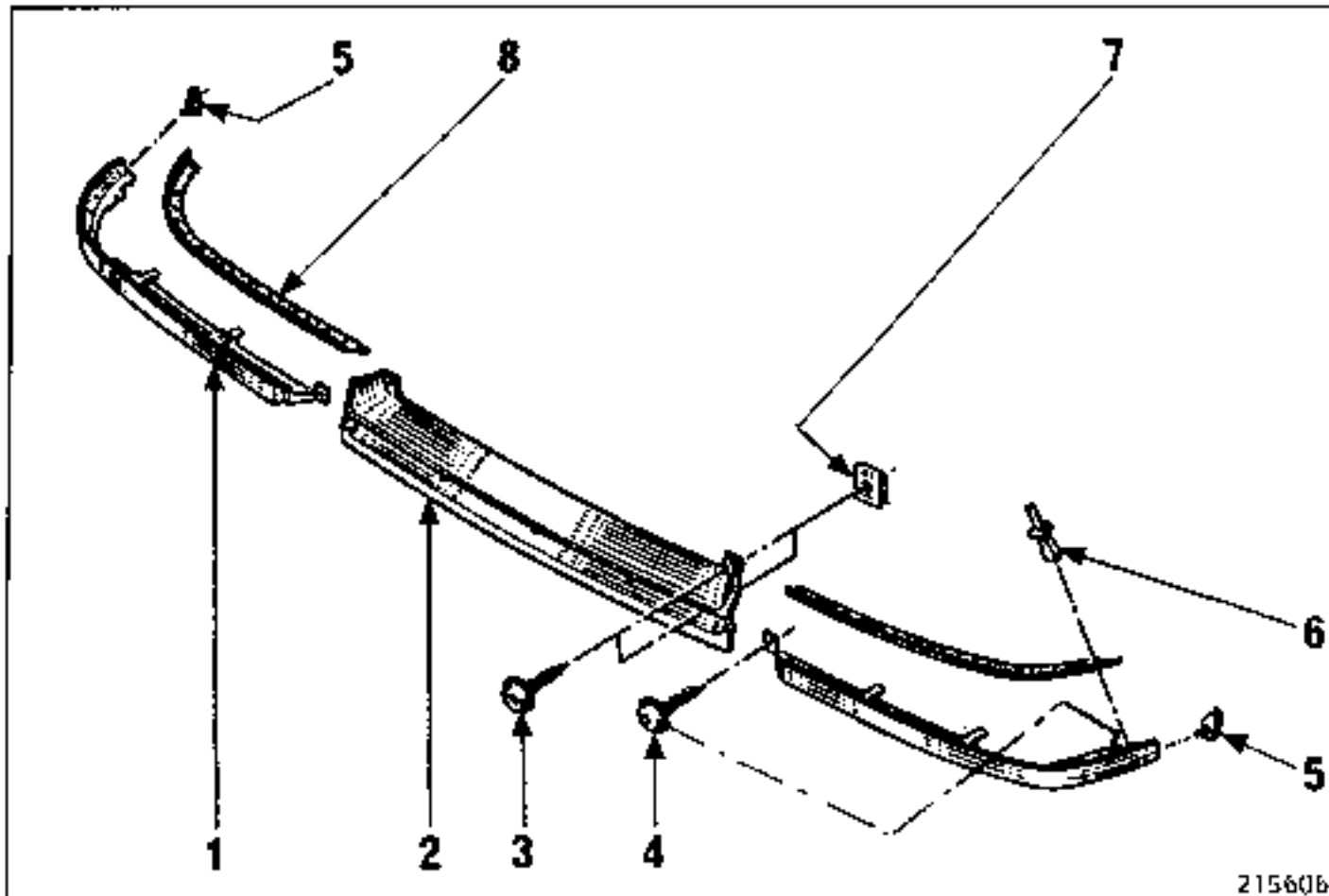

- 1 Front end moulding
- 2 Radiator grille
- 3 Sheet metal screw
- 4 Sheet metal screw

- 5 Front end moulding stop
- 6 Plastic pin
- 7 Sheet metal screw clip
- 8 Front end moulding adhesive seal

REMOVAL

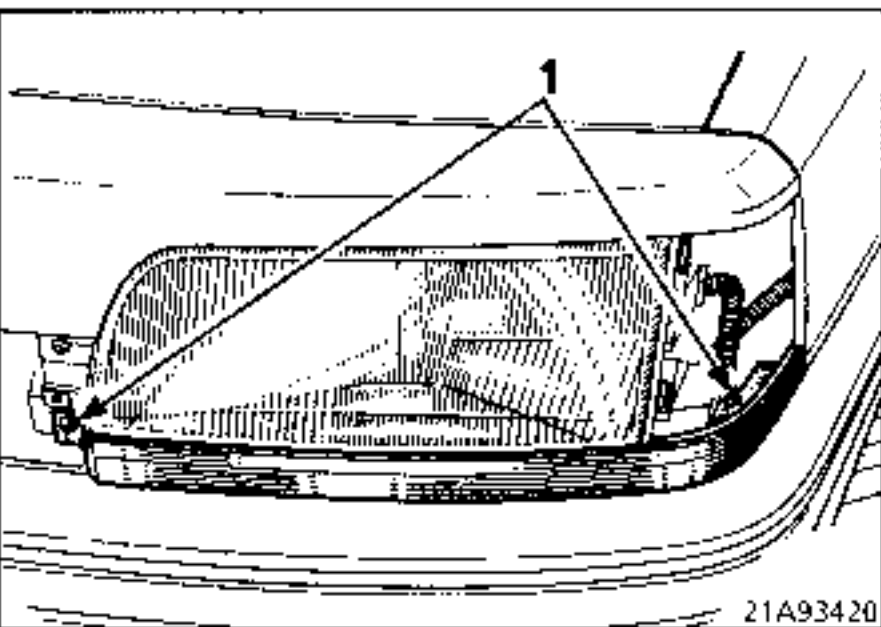

Remove :

- the radiator grille,
- the direction indicator,
- the two Torx type screws (4) and pull the moulding towards the front.

REMOVAL

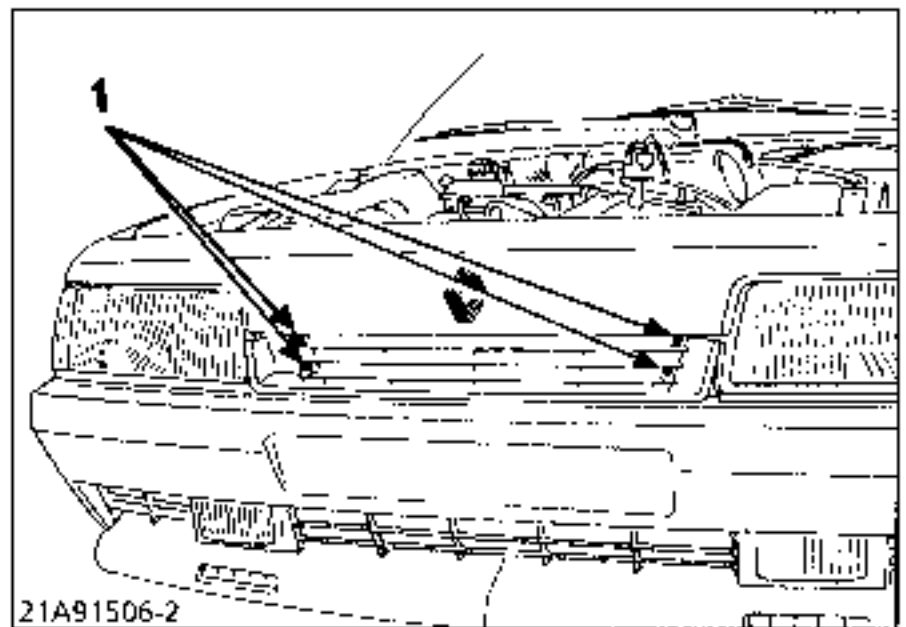

Remove the four Torx type screws (3) and free the grille from its location.

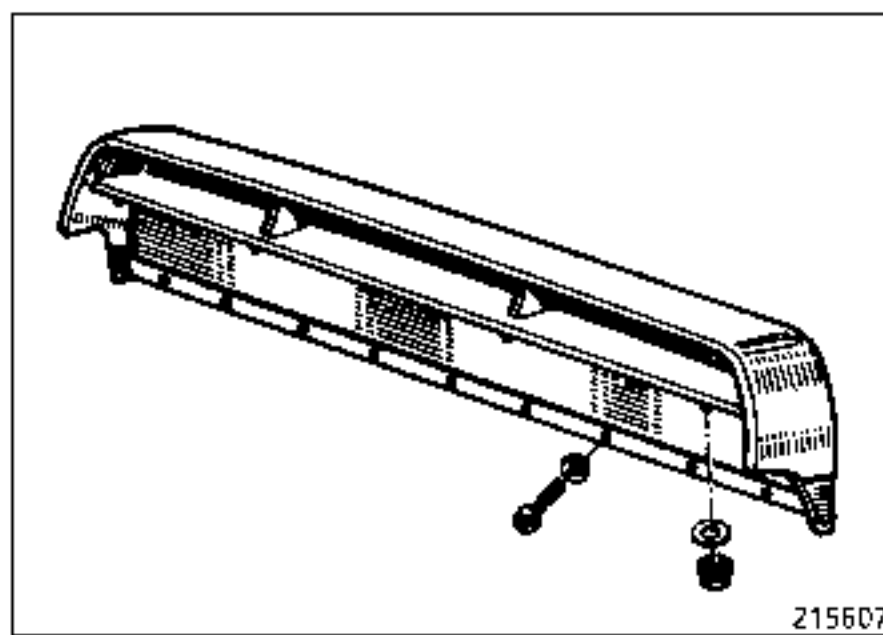

Material : Polyurethane
(P.U.)

For drilling dimensions for the boot lid, please refer to Section 4.

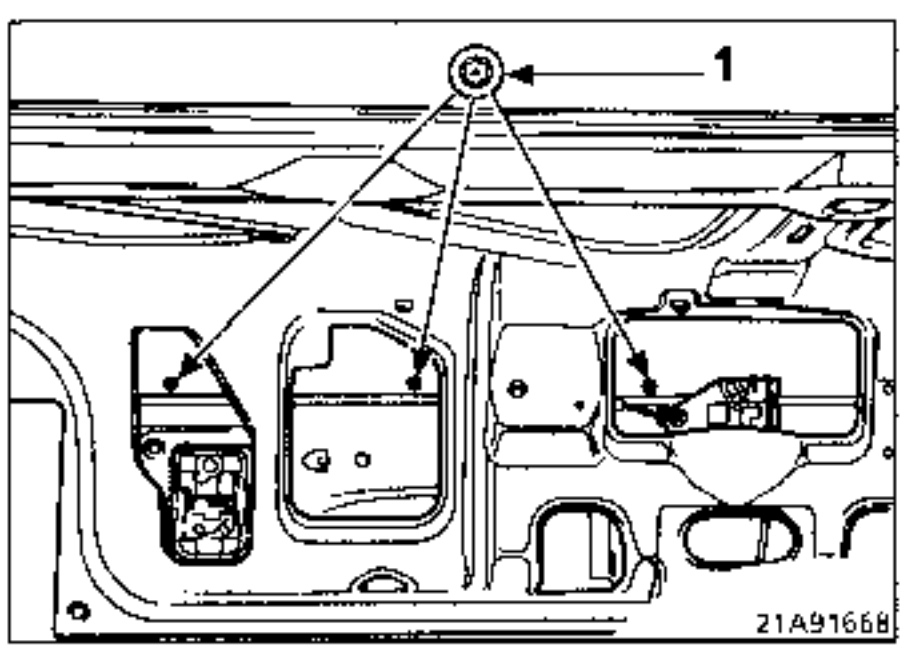

IMPORTANT :

The boot lid is balanced by special compensating springs owing to the heavy weight of the boot lid spoiler. If the boot lid has to be replaced, it is recommended that it is stripped after removal. Otherwise, if the boot lid without the spoiler is opened, great care must be taken and it must be held while it is raised.

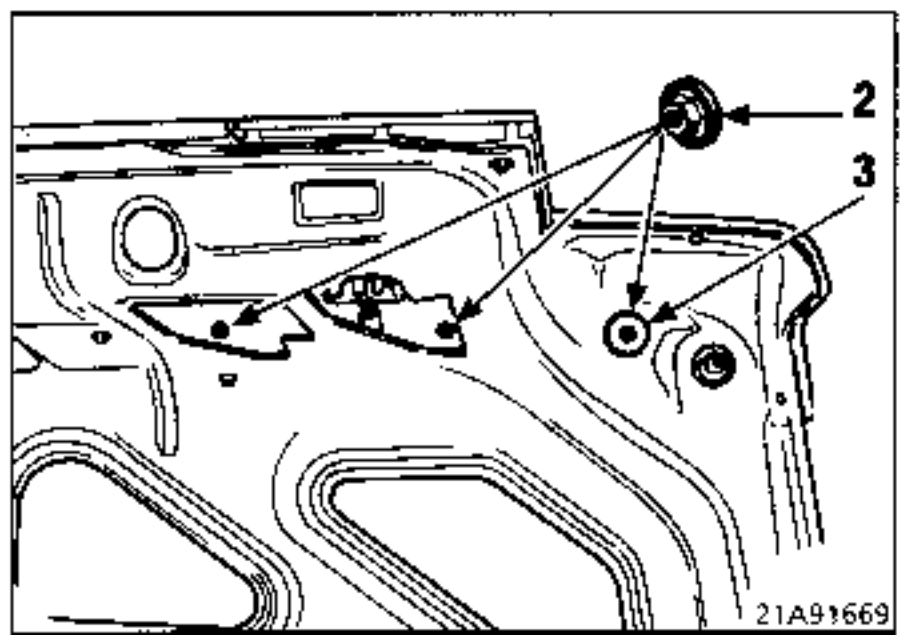

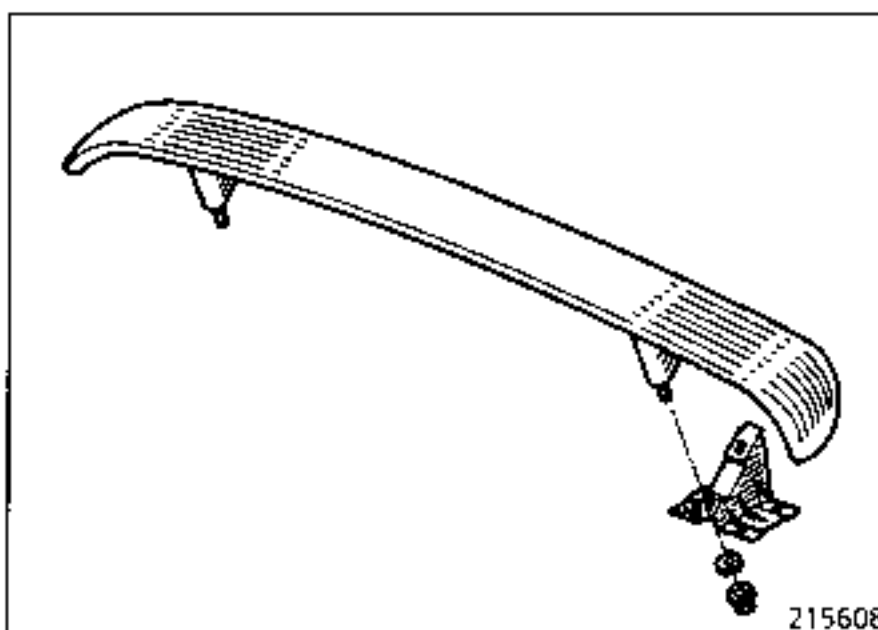

Material : Polyurethane
(P.U.)

FITTING

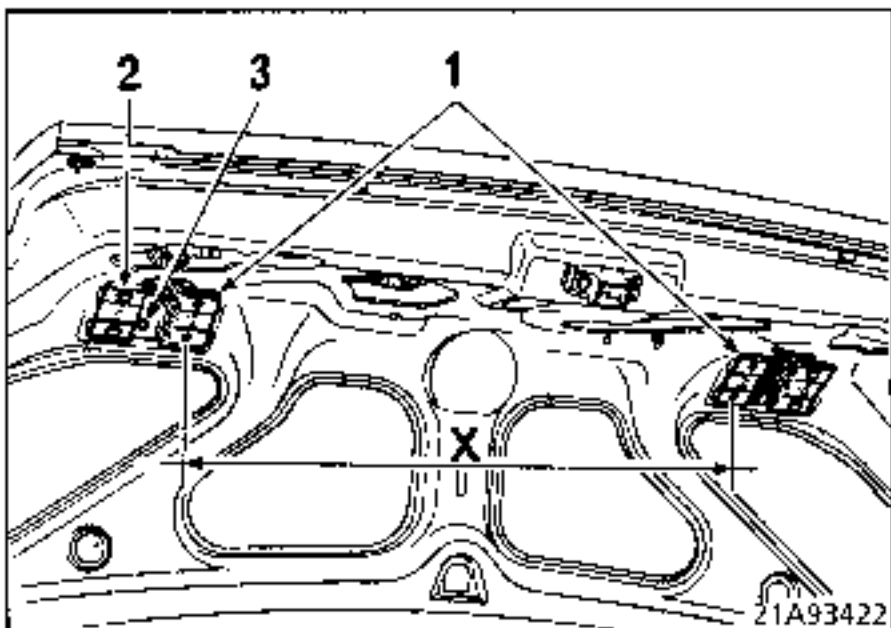

Fit in place the two strengtheners (1) using screws (2), but do not tighten them. Centre them and adjust the distance X between them to the dimension shown in the drawing :

$$X = 640 \text{ mm.}$$

Using a centre punch, mark the location of the four points (3) for mounting the boot lid spoiler.

Remove the two strengtheners.

From the outside drill the four holes (3) to a diameter of 8 mm.

NOTE : In service exchange the rear boot lid is supplied without the strengtheners.

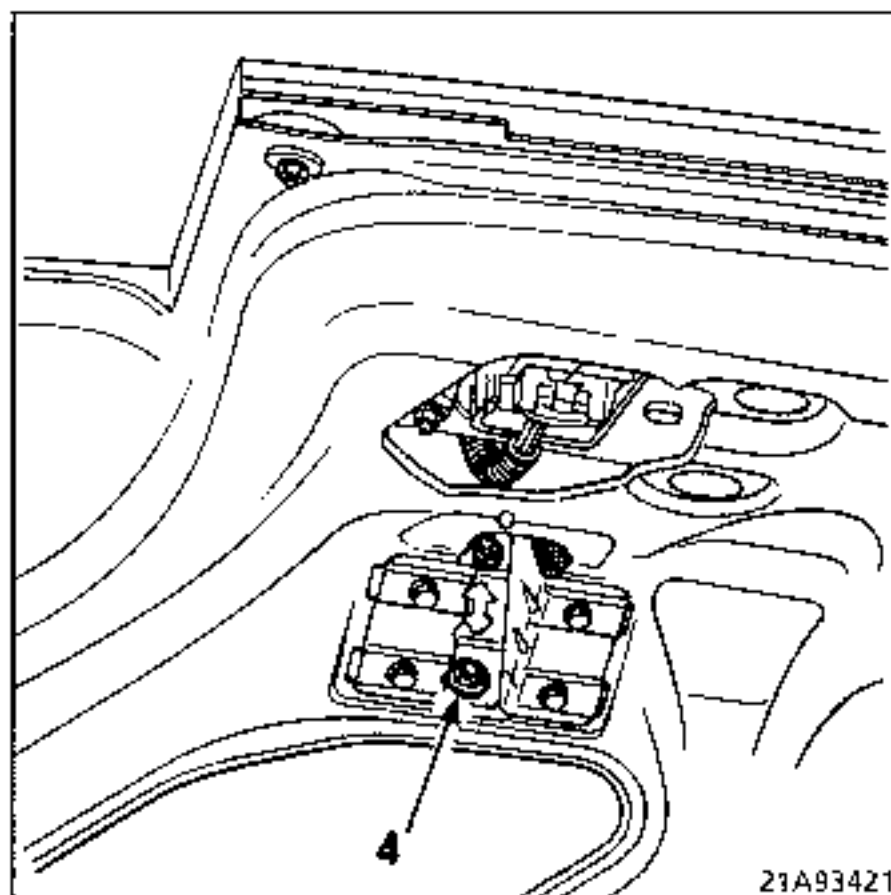

Refit the two strengtheners.

From the outside, apply sealing mastic to the edge of the mounting holes.

Fit the spoiler and secure it using the four nuts (4).

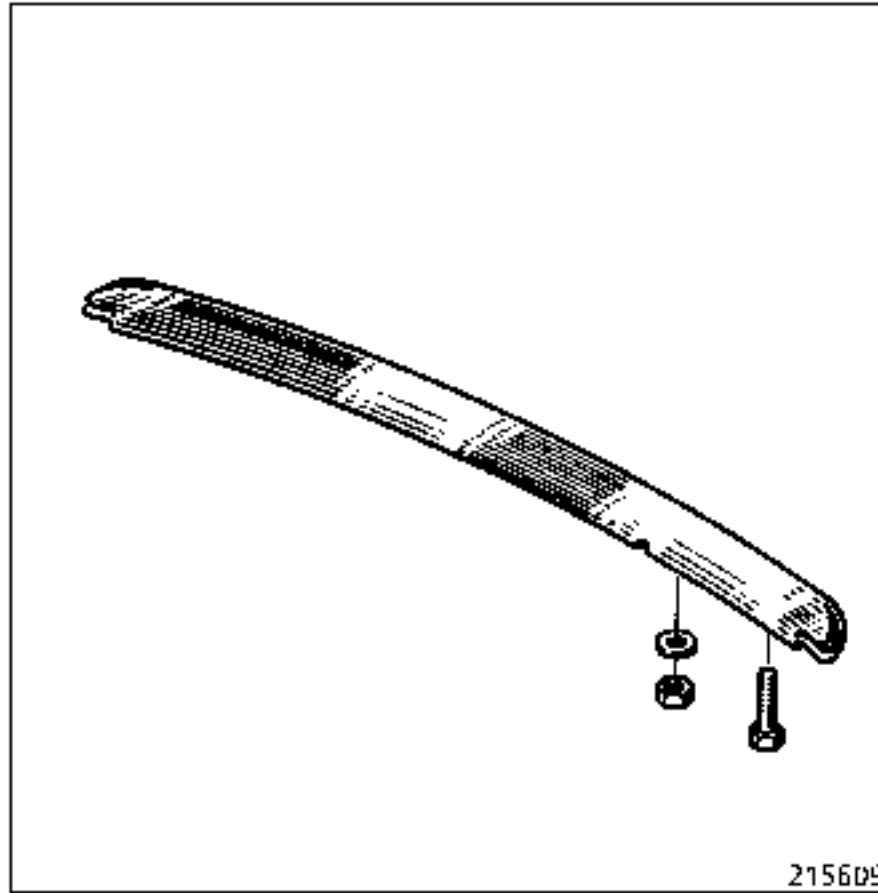

The rear screen wiper (motor) and the tailgate lock motor mounting must be removed in order to remove the tailgate spoiler.

NOTE :
In the event of removal/refitting without replacement of the spoiler, all the adhesive tape must be removed from the spoiler and the tailgate.

Carefully degrease the spoiler using an acetone type solvent.

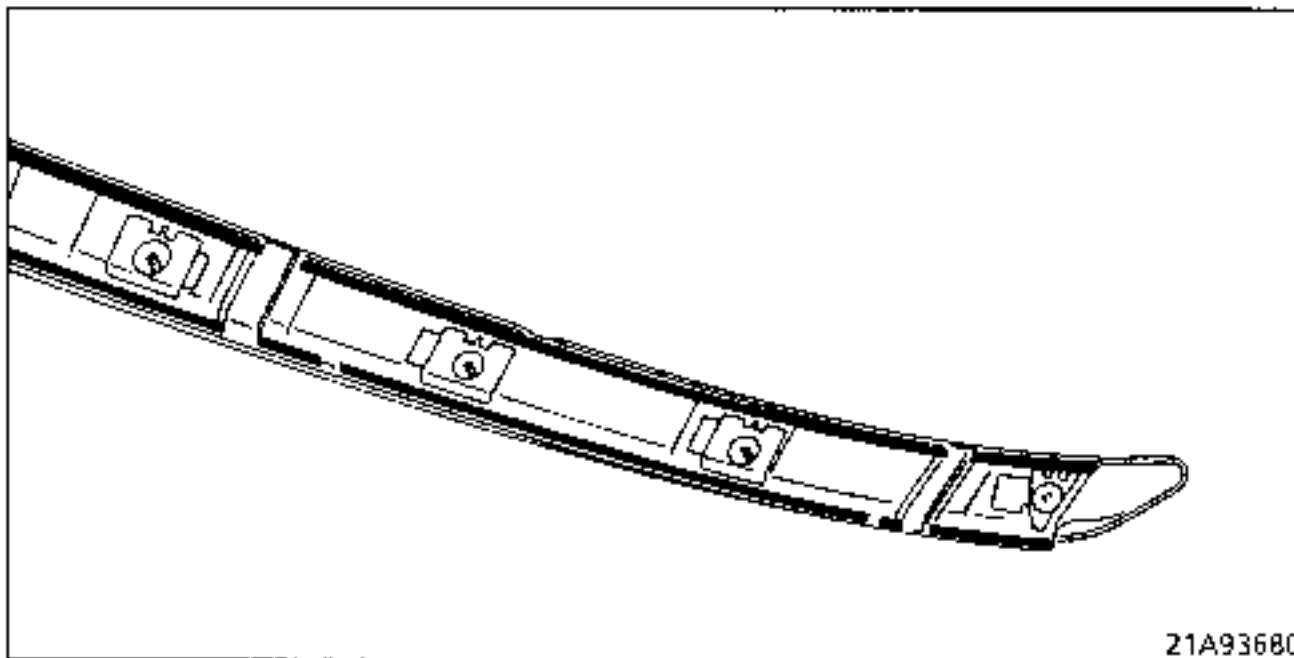

Refit double-sided tape to the spoiler taking great care to keep the drain holes clear.

1 - FITTING THE ROOF RACK BARS

It is not possible to assemble the roof rack mounting strengtheners to the service exchange body during production.

In service, therefore, when replacing a body shell or a roof on a vehicle with a roof rack, these strengtheners will have to be assembled.

This operation is to be performed when the vehicle is being painted.

- Part Number for strengtheners : **77 00 783 932** quantity 6
- Part number for bonding mastic for metal : **77 01 406 775** quantity 1

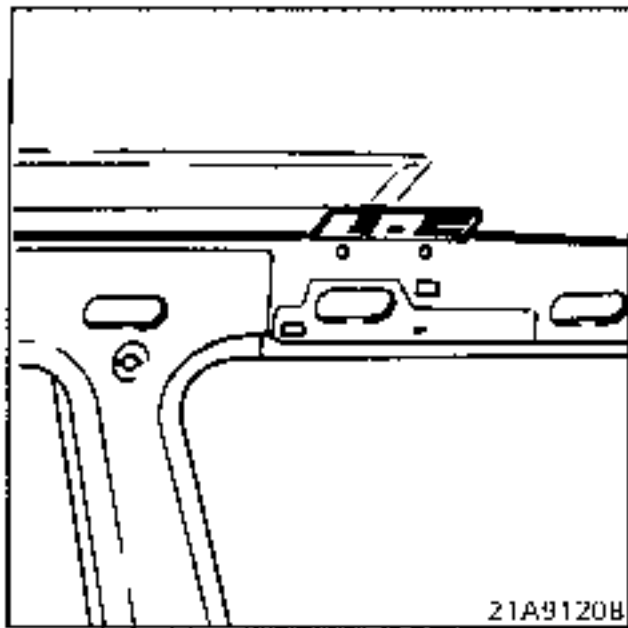

21A91208

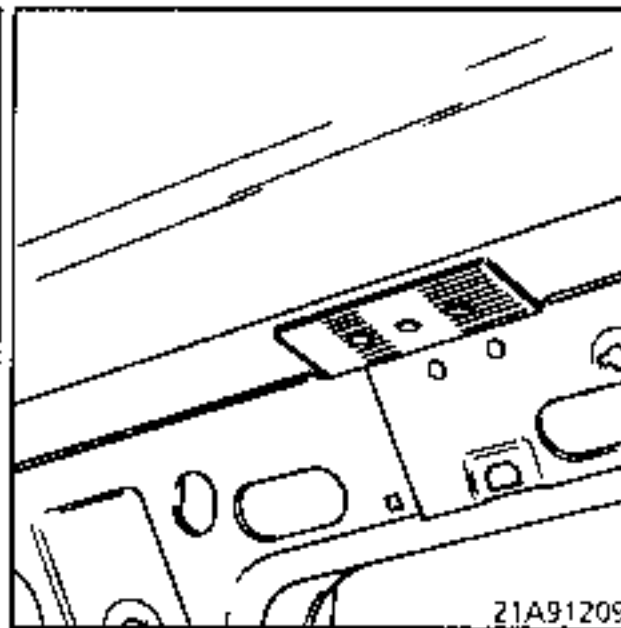

21A91209

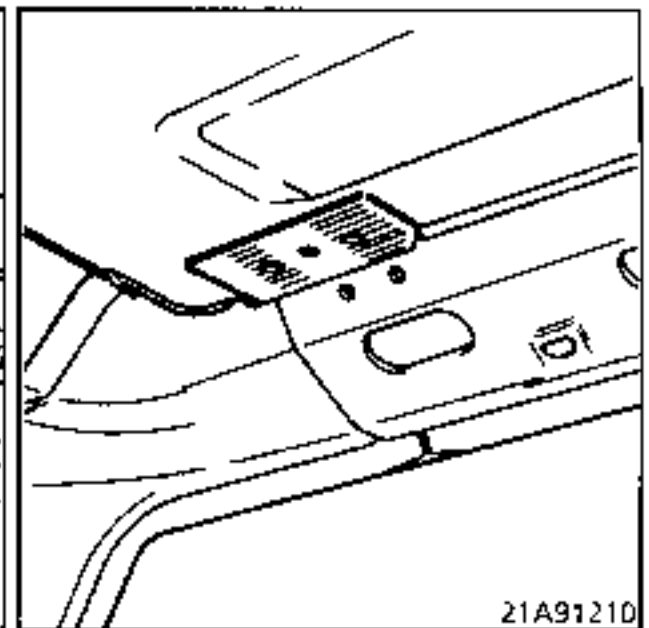

21A91210

Front mounting strengthener

Centre mounting strengthener

Rear mounting strengthener

ASSEMBLY METHOD**Drilling the mountings :**

- Drill the mountings for the side bars using the templates 1 and 2 supplied with this document.
- Drill the centre mounting using the roof rack bar as a guide.

Bonding the six strengtheners :

- Clean the bonding faces of the strengtheners and the roof.
- Prepare the bonding mastic for metal.
- Apply the required quantity of mastic to each strengthener.
- Fit the strengtheners in place and retain them by means of nuts and side bars (run the bolts up by hand without tightening them to a torque of 500 g).
- Leave the bonding mastic for metal to polymerise.

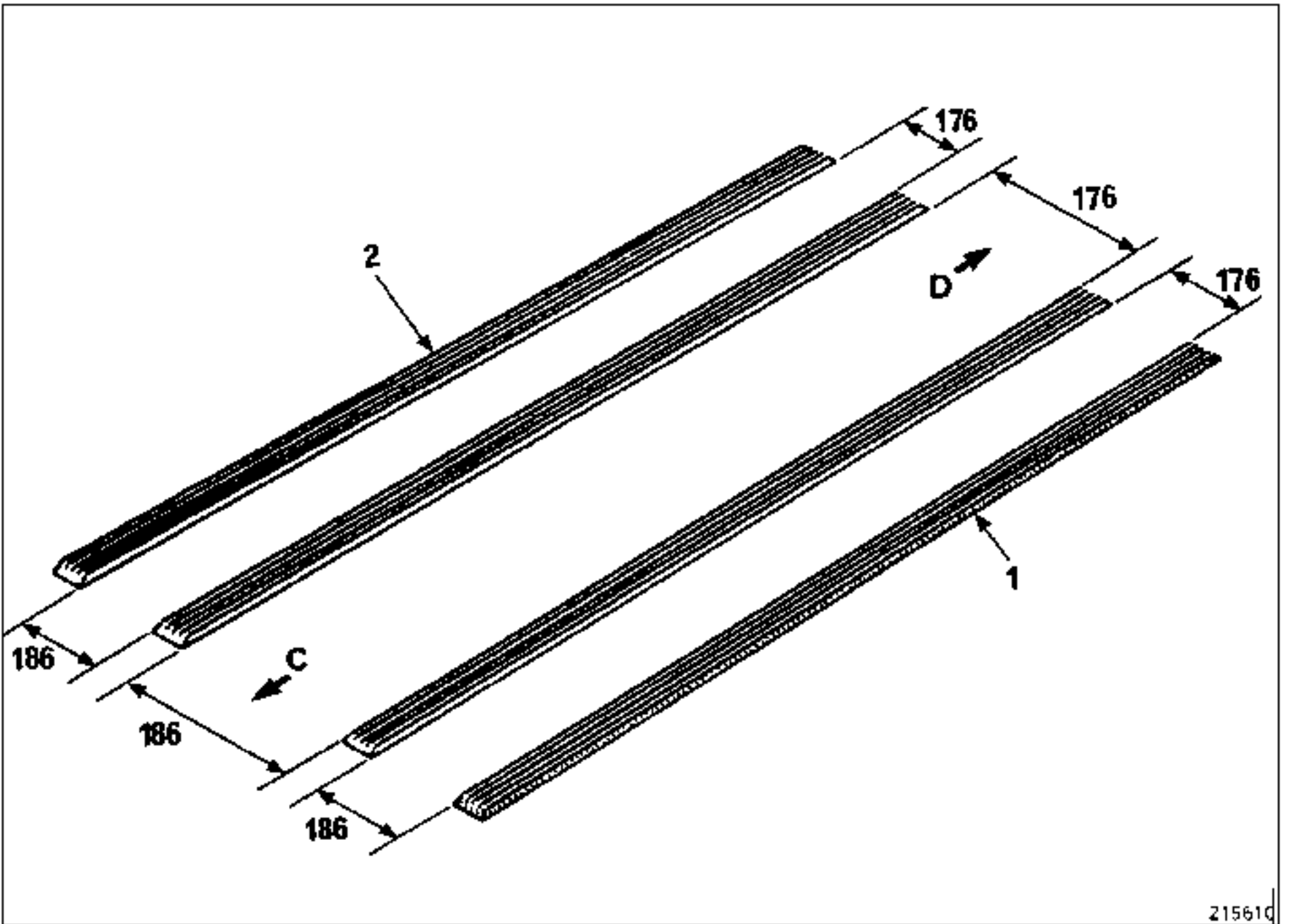

C Front of vehicle

D Rear of vehicle

Dimensions for sticking on the self-adhesive strips.

See the template for positioning strips 1 and 2.

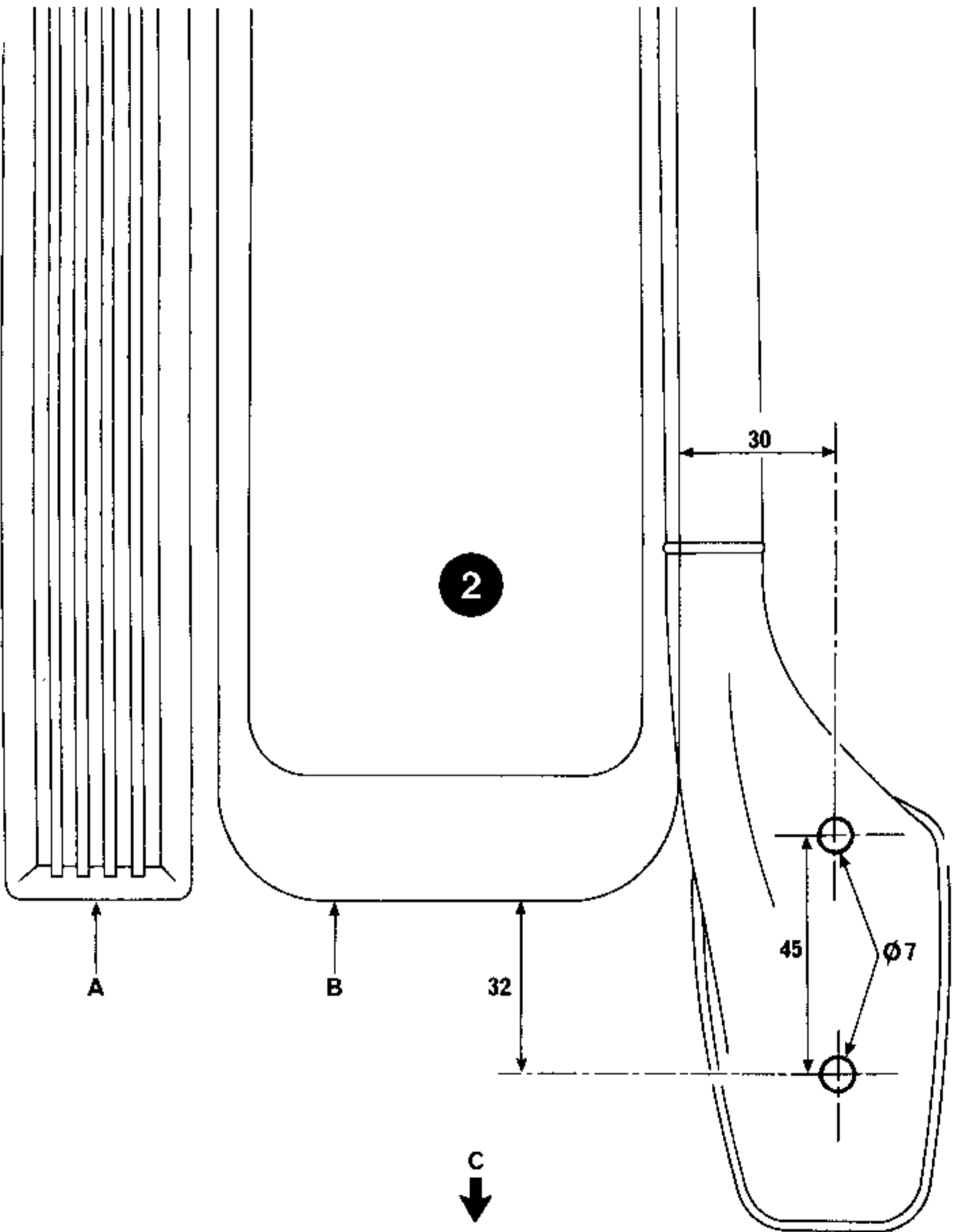

2

30

45

Ø7

32

A

B

C

Z1A91201

A Self-adhesive strip
B Roof moulding rib
C Front of vehicle

(2) FRONT LEFT-HAND MOUNTING DRILLING TEMPLATE
(right-hand side symmetrical)

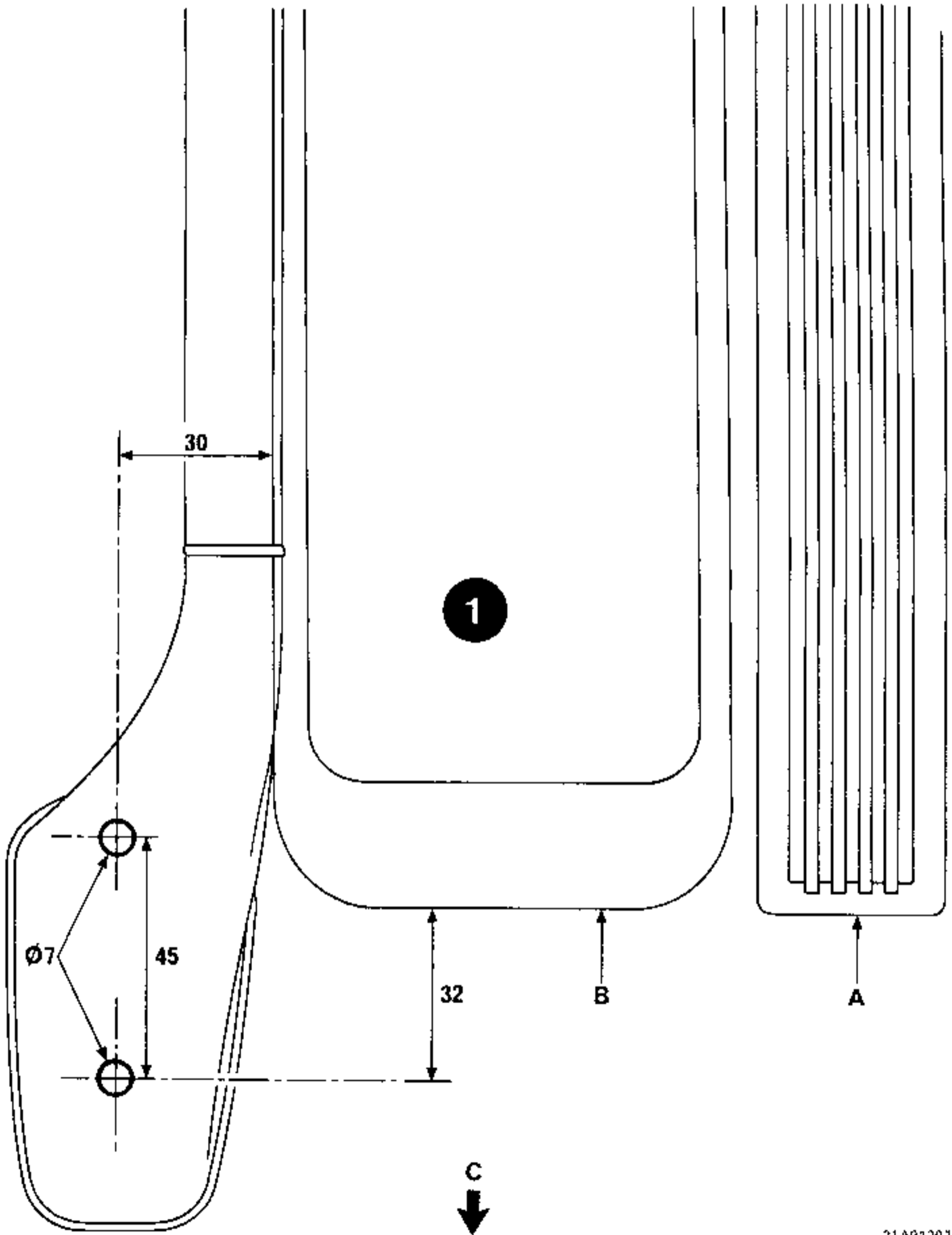

A Self-adhesive strip
B Roof moulding rib
C Front of vehicle

(2) FRONT LEFT-HAND MOUNTING DRILLING TEMPLATE
(right-hand side symmetrical)

21A91207

- 1 Upper face
- 2 Face mounting screw
- 3 Gaiter plastic frame
- 4 Gaiter
- 5 Upper face (automatic transmission)
- 6 Sliding cover
- 7 Gear indicating plate
- 8 Bulb
- 9 Handbrake console
- 10 Handbrake console nut
- 11 Clip for metal screw
- 12 Milled metal screw
- 13 Plastic clip for metal screw
- 14 Clip for metal screw
- 15 Console mounting
- 16 Mounting securing nut on tunnel
- 17 Centre console
- 18 Clip
- 19 Console mounting screw

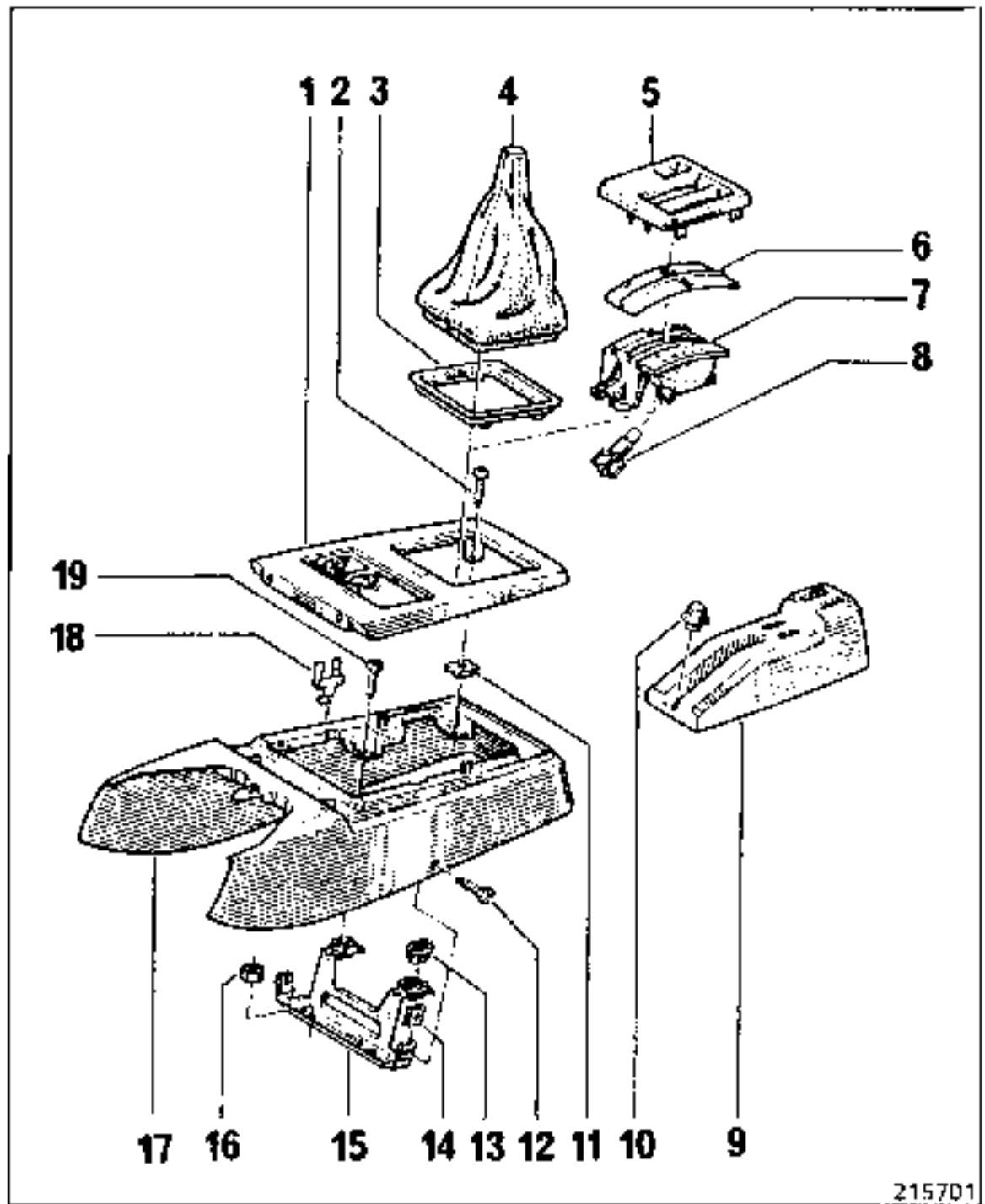

215701

Removal

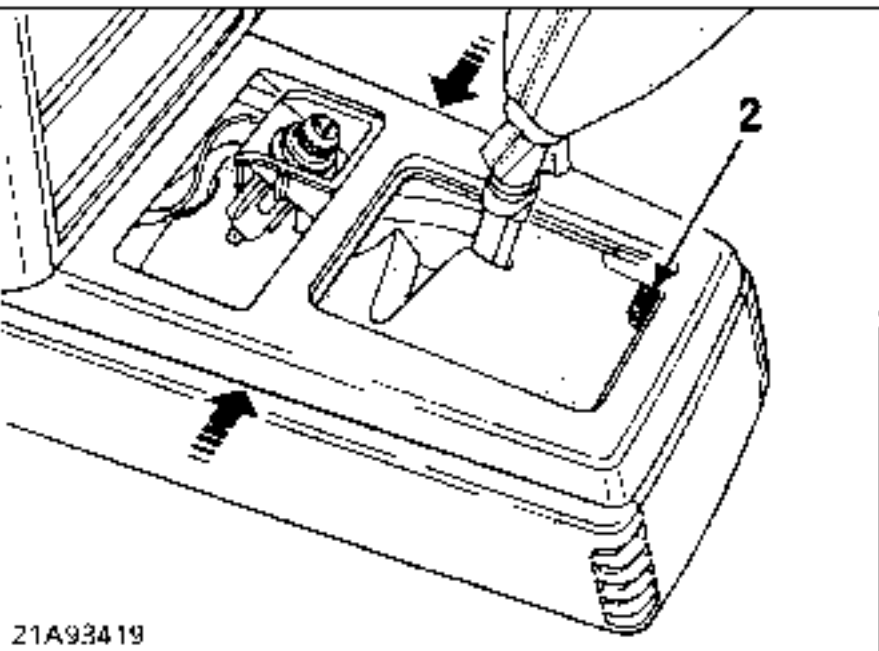

21A93419

- Remove the ash tray.
- Disconnect the cigar lighter.
- Disengage the gear lever gaiter.

Remove :

- the two screws (2) and unclip the upper face from the console to remove it,

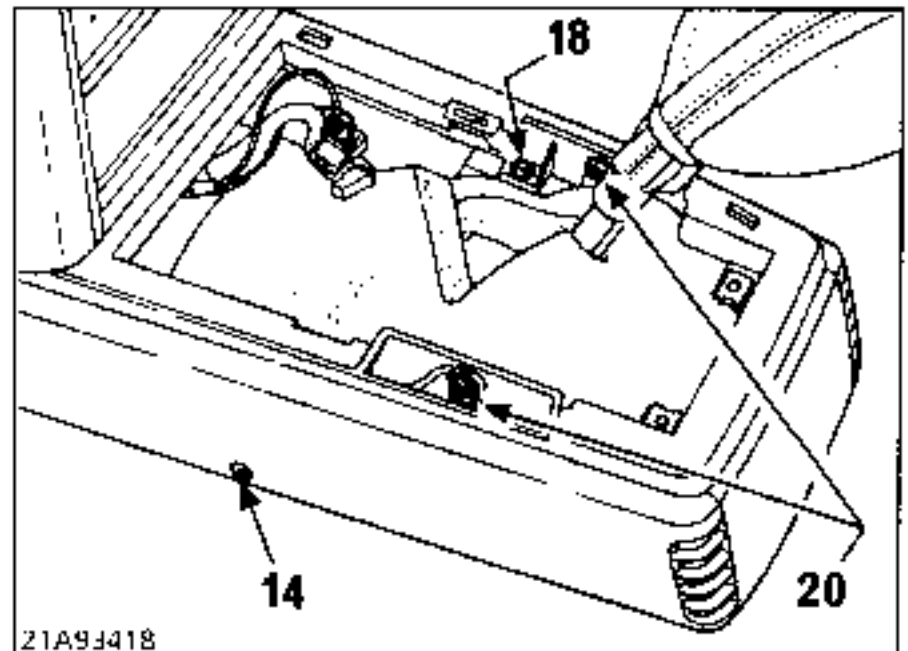

21A93418

- the two screws (20) securing the air ducts,
- the four screws (14) and (18) securing the console.

Pull on the handbrake lever and the console lifting towards the rear to remove it.

Removal

Disconnect the battery.

Remove :

- the centre console,
- the lower trim on the left and right-hand body sides,
- the steering wheel, after first marking its position,
- the lower and upper half shells from the steering wheel which are secured to one another by four screws.

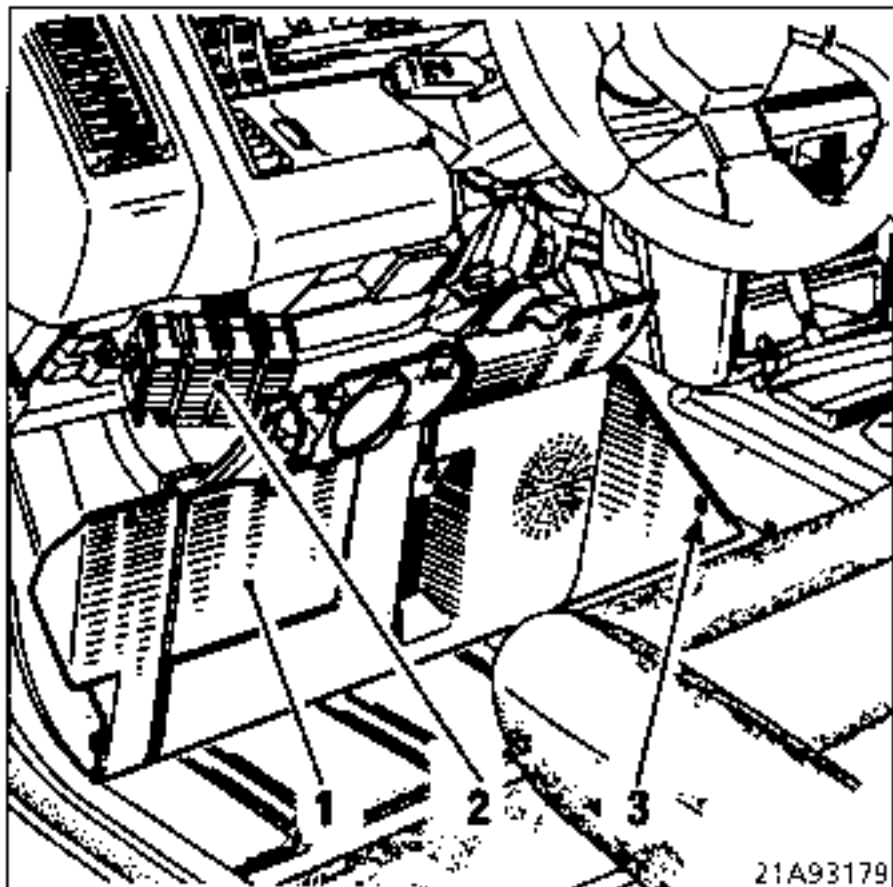

21A93179

Open flap (1).

Unclip the fuse box (2).

Raise the steering wheel height adjusting control lever.

Remove :

- the nine screws (3) securing the trim under the steering wheel and tilt the trim to remove it,
- the trim on the left-hand side of the glovebox.

COLD START DEVICE (DEPENDING ON VERSION)

Removal

Unclip the cable from the carburettor.

Remove the two anti-noise foam pads located on the control sheath.

Unclip :

- the warning light connector,
- the choke knob from the dashboard and remove the entire control equipped with the sheathing and the cable.

STEERING COLUMN

Removal

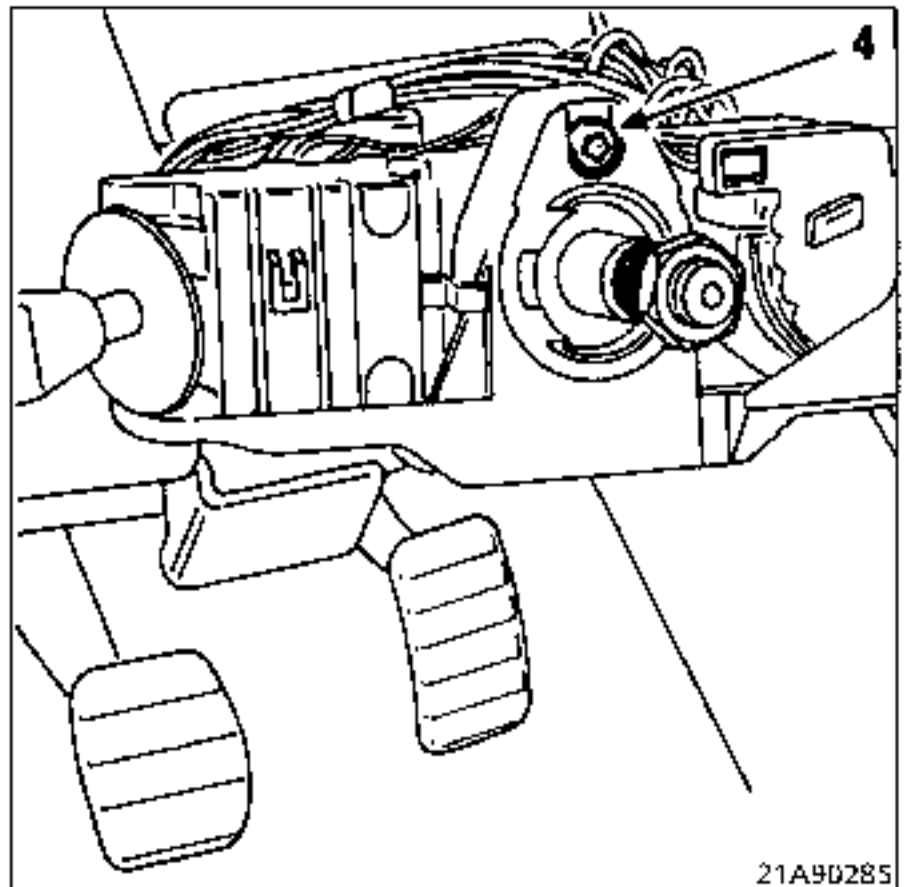

21A90285

Slacken screw (4) but do not remove it, then push it in so as to release the tightening cone.

Disconnect :

- the connectors and remove all the controls,
- the starter switch.

Fit in place the steering wheel without securing it and turn it so that the universal joint mounting bolt can be reached.

Remove the universal joint mounting bolt.

Remove the ignition key and lock the starter switch.

Remove the five steering column mountings (two hexagon head bolts, two nuts and a Torx type bolt).

Tilt the steering column downwards and pull it to remove.

HEATING/VENTILATION CONTROL PANEL AND RADIO MOUNTINGS

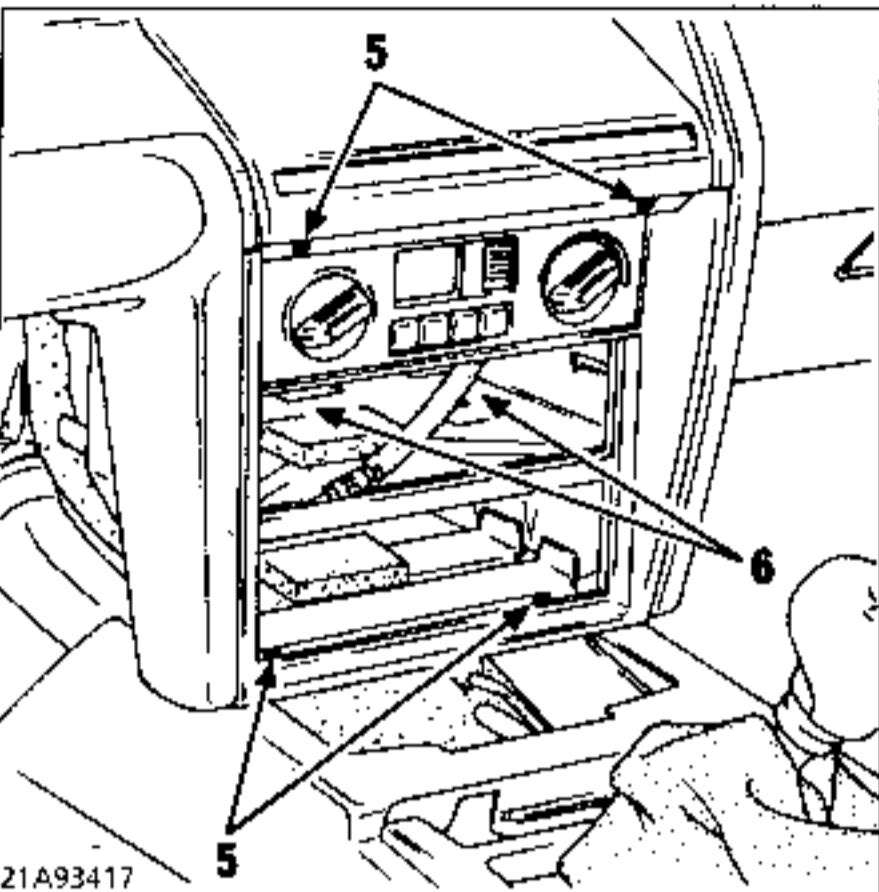

Remove :

- the radio or the radio compartment moulding,
- the lower compartment unit,
- the four screws (5) holding the front panel.
- the two nuts (6) securing the base of the mounting.

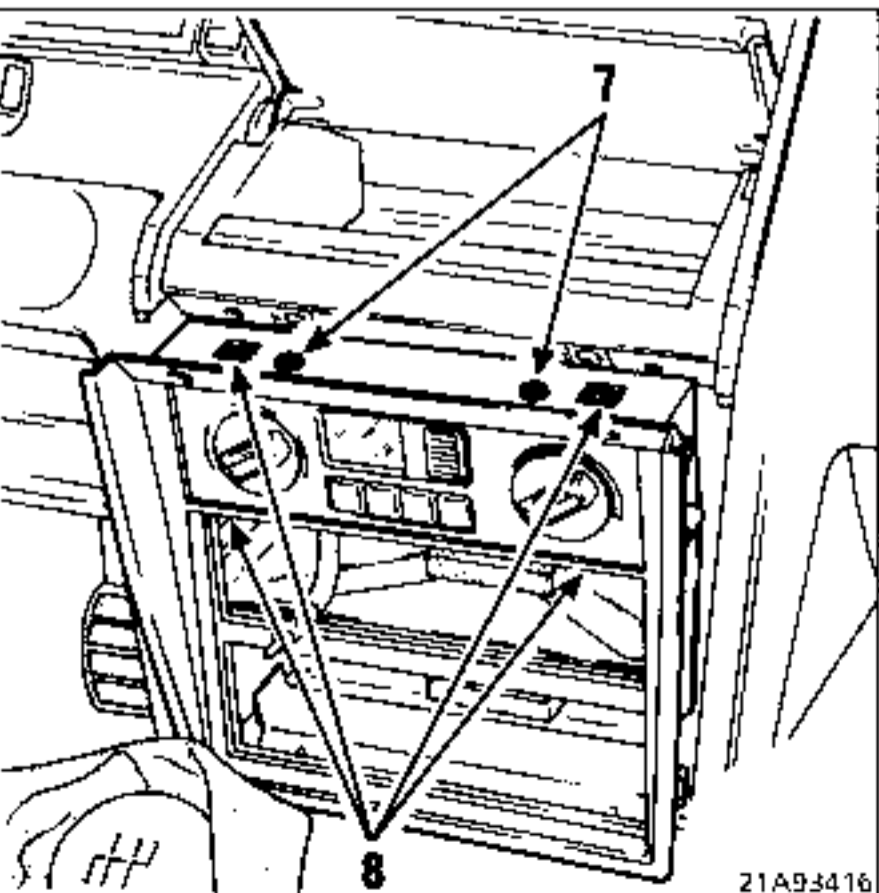

Gently take out the dashboard mounting.

Remove the two screws (7) holding the control panel on its mounting.

Unclip the four lugs (8) holding the panel and push the panel inwards.

Remove the mounting bracket by tilting it downwards.

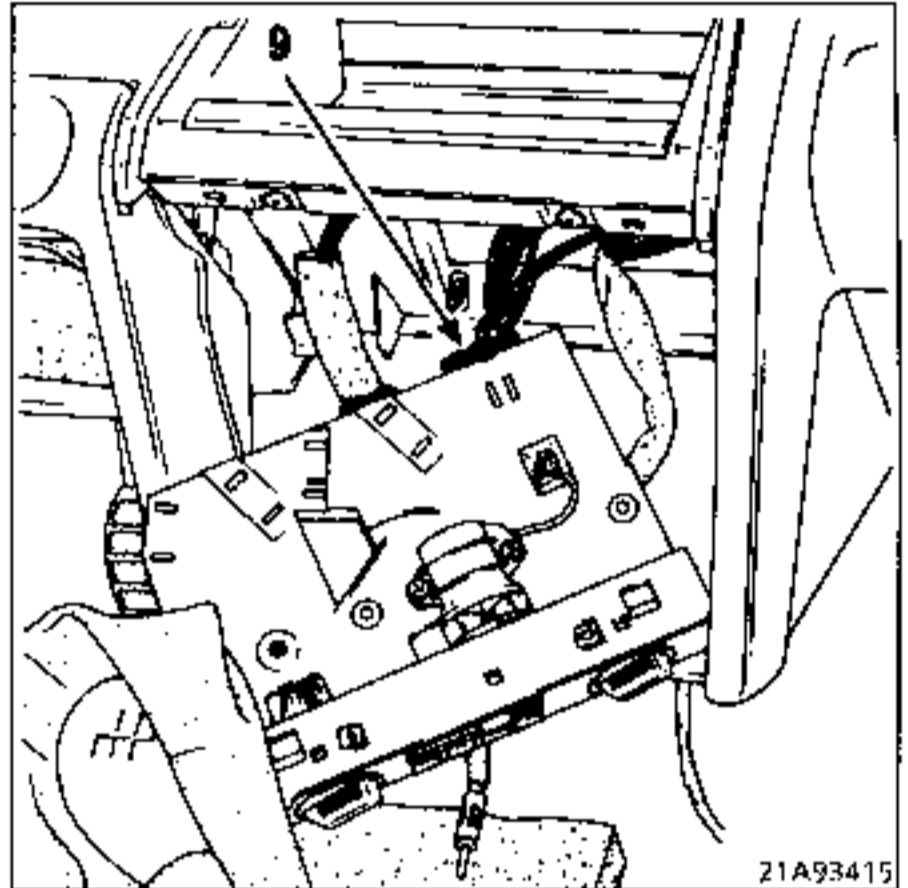

Disconnect the electric feed connector (9) (colour brown) from the dashboard without removing it.

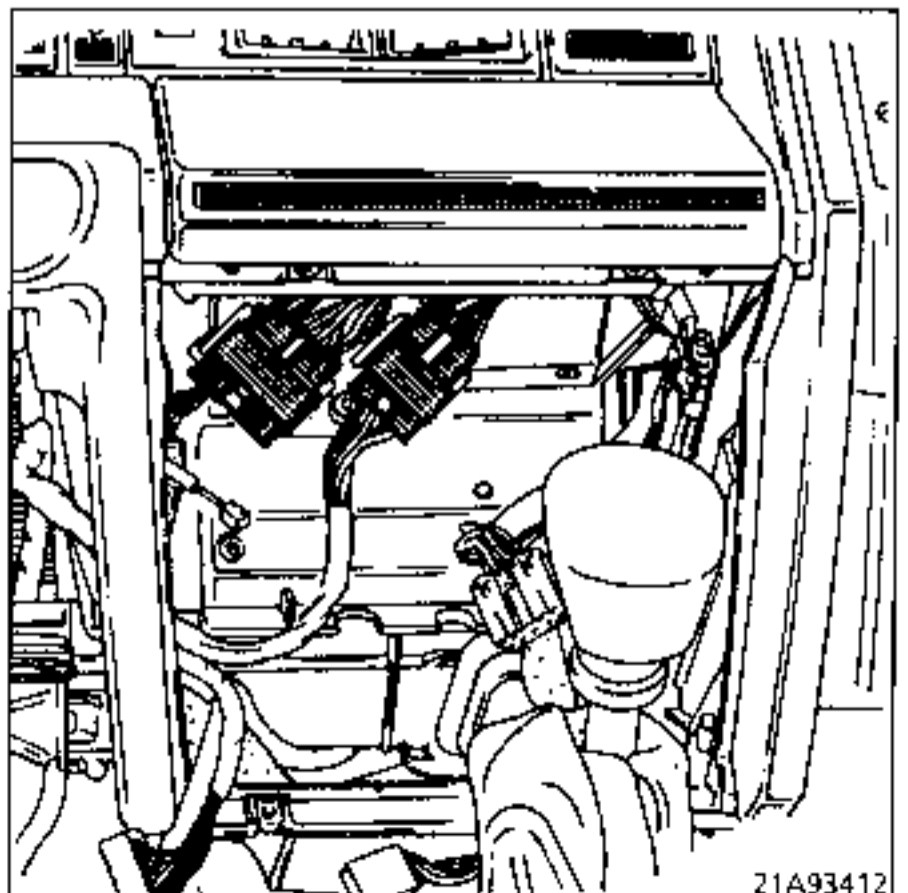

Disconnect the two connectors located on the air distribution unit.

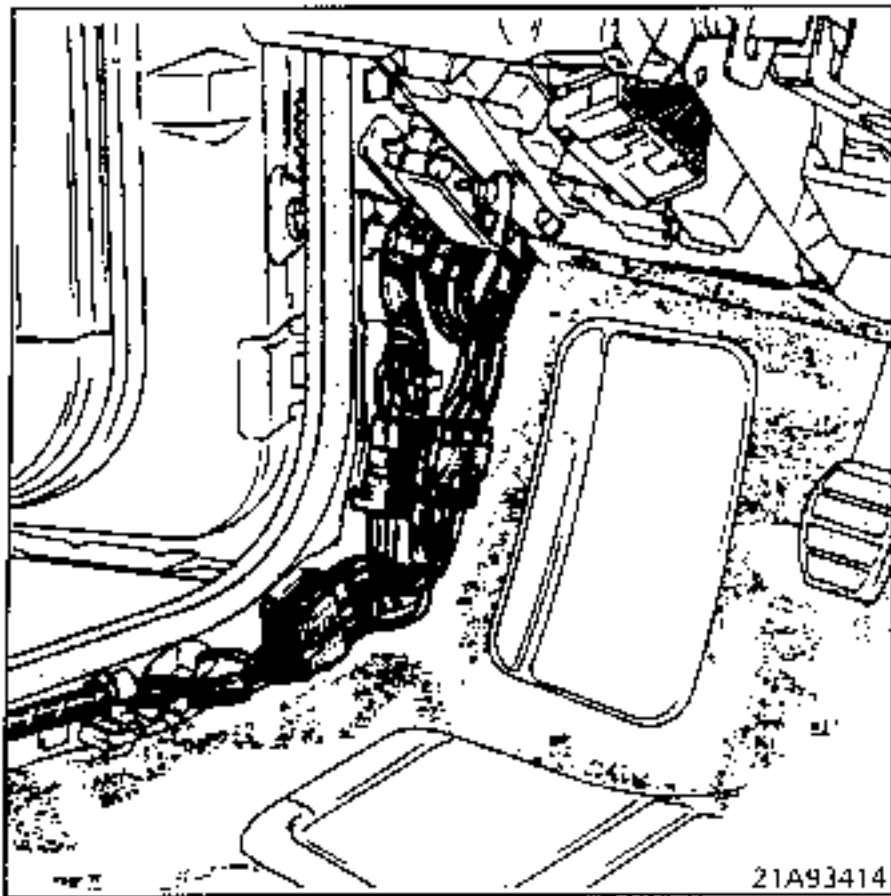

Disconnect :

- the speedometer cable,
- the pulse generator located on the speedometer cable (depending on version),

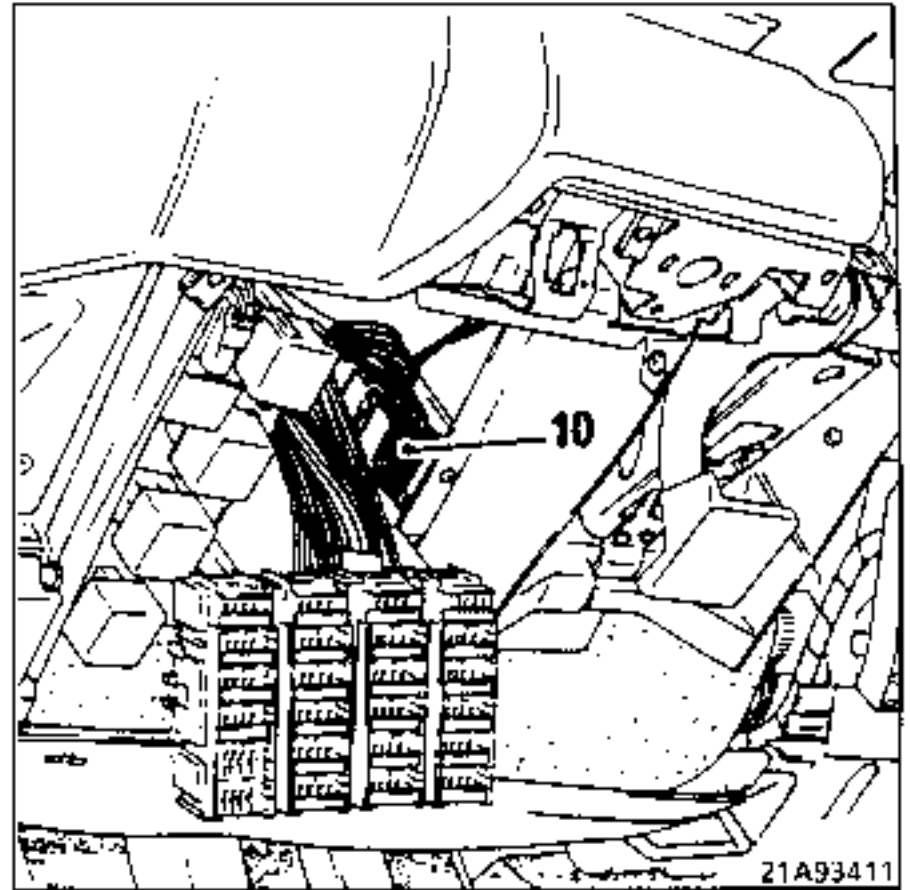

- connector (10) from the scuttle panel harness.

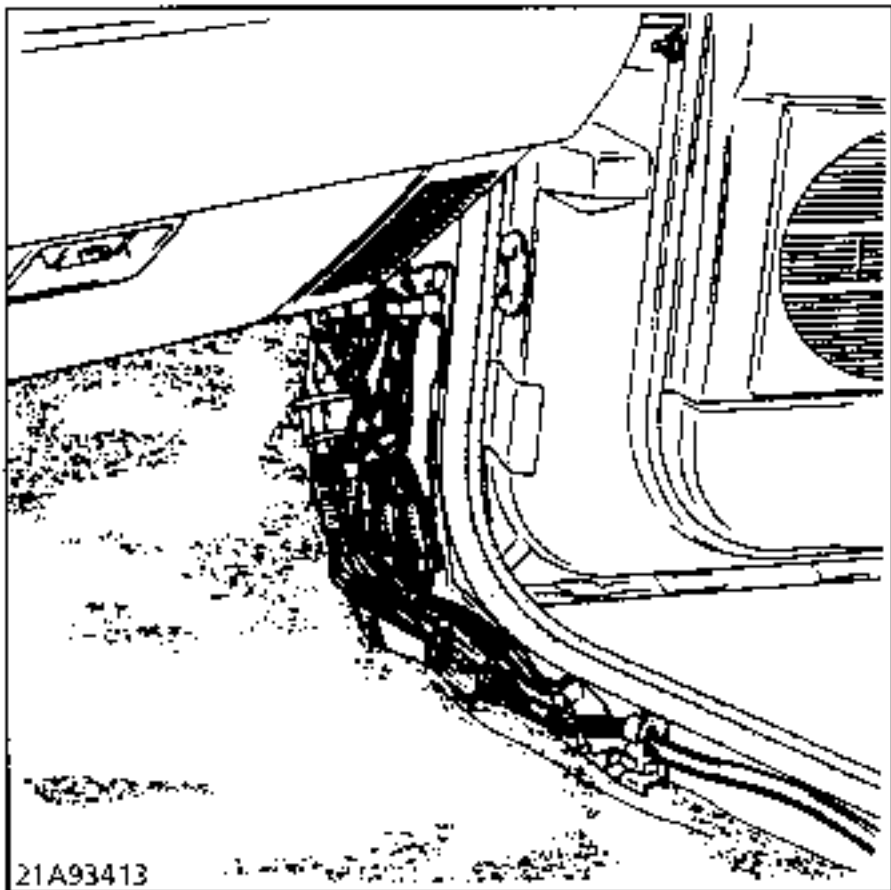

Disconnect the connectors from the front left-hand and right-hand pillars and remove the mounting bolts from the earth terminals.

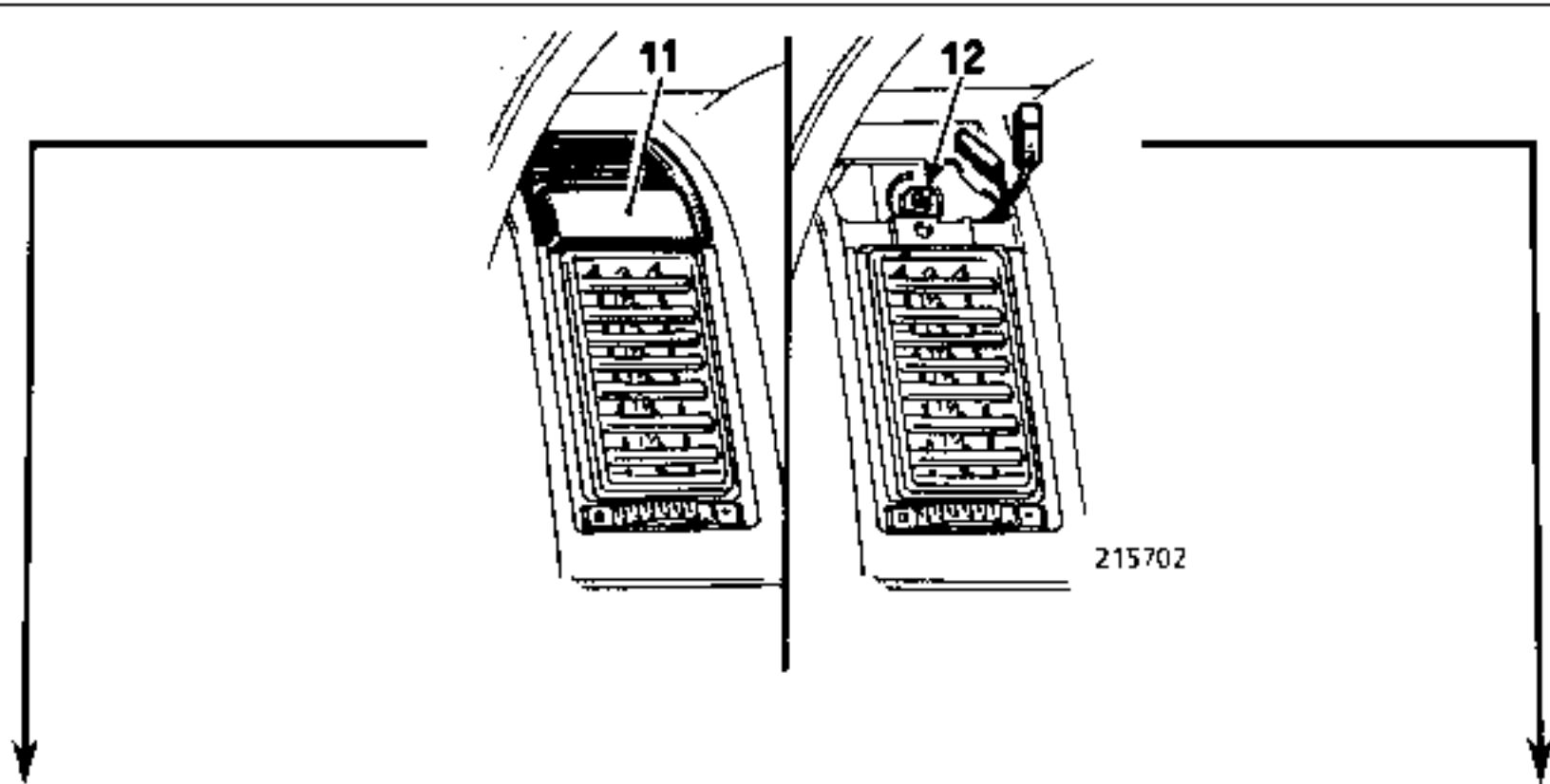

On the left and right-hand sides :

Unclip moulding (11).

Remove :

- the speaker grille,
- the two lower mounting bolts (13),
- the two upper mounting nuts (12),
- the dashboard.

Refitting

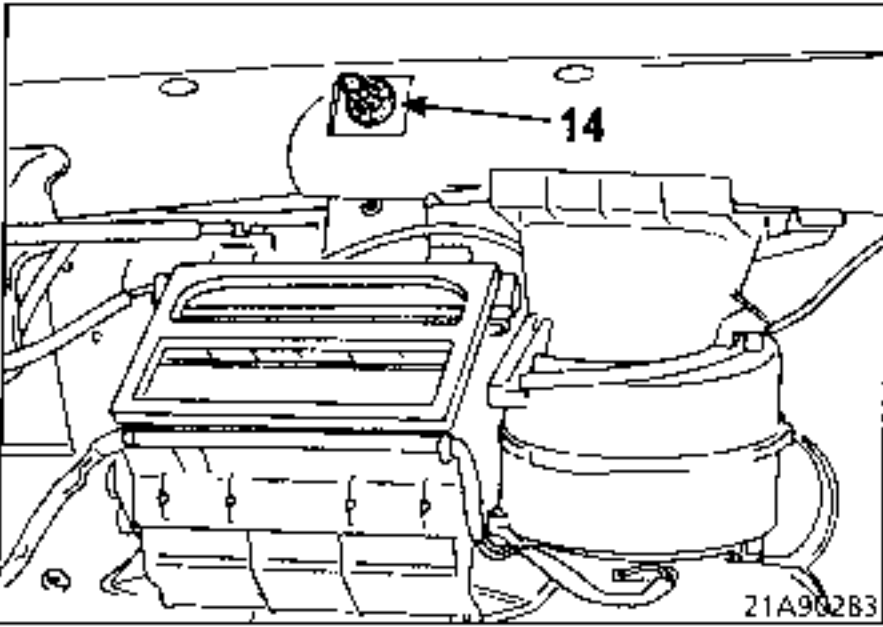

Check that the plastic locating device (14) is fitted.

Fit the dashboard on the locating device and the four mounting points (make sure that the wiring harness and the steering intermediate shaft are routed correctly).

Secure the dashboard.

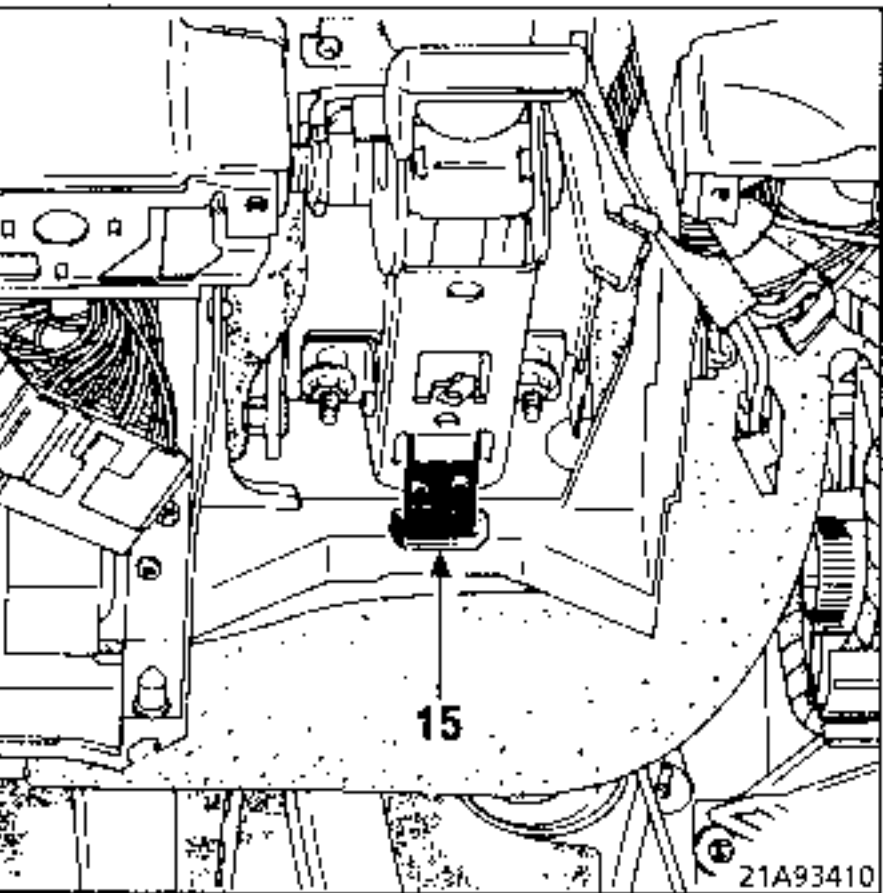

Offer up the steering column, engaging tab (15) in its location and the steering shaft in the universal joint.

Secure the steering column.

Fit the universal joint mounting bolt but do not tighten it.

When refitting the steering wheel, adjust the depth to which the steering wheel shaft is inserted and tighten the universal joint bolt.

Refit :

- the radio mounting,
- the heating/ventilation control panel.

Reconnect :

- the speedometer cable,
- all the connectors and earth leads.

Connect the battery, with the ignition switched off and check all functions before refitting the trim.

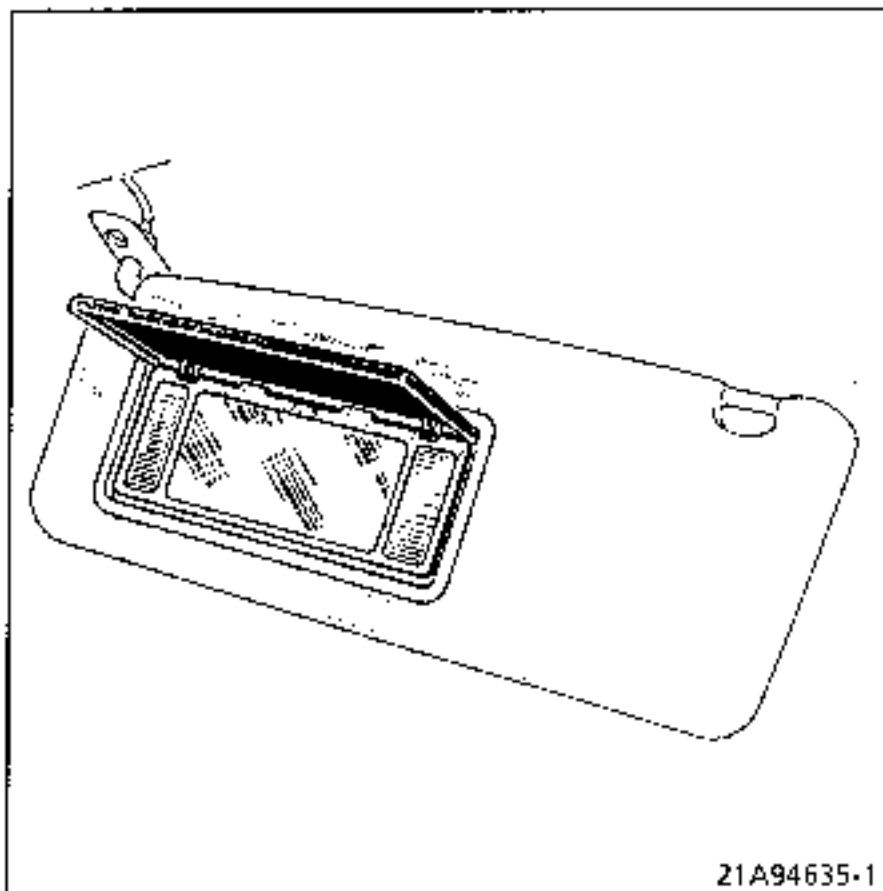

REMOVAL

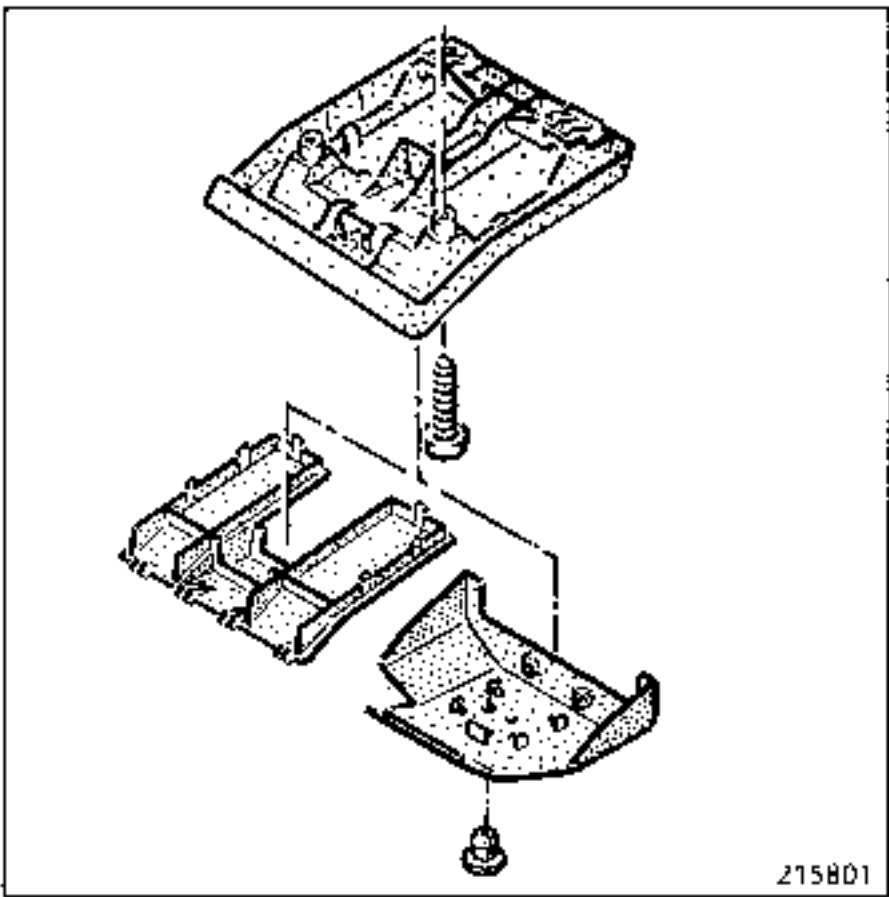

Remove the roof panel console.

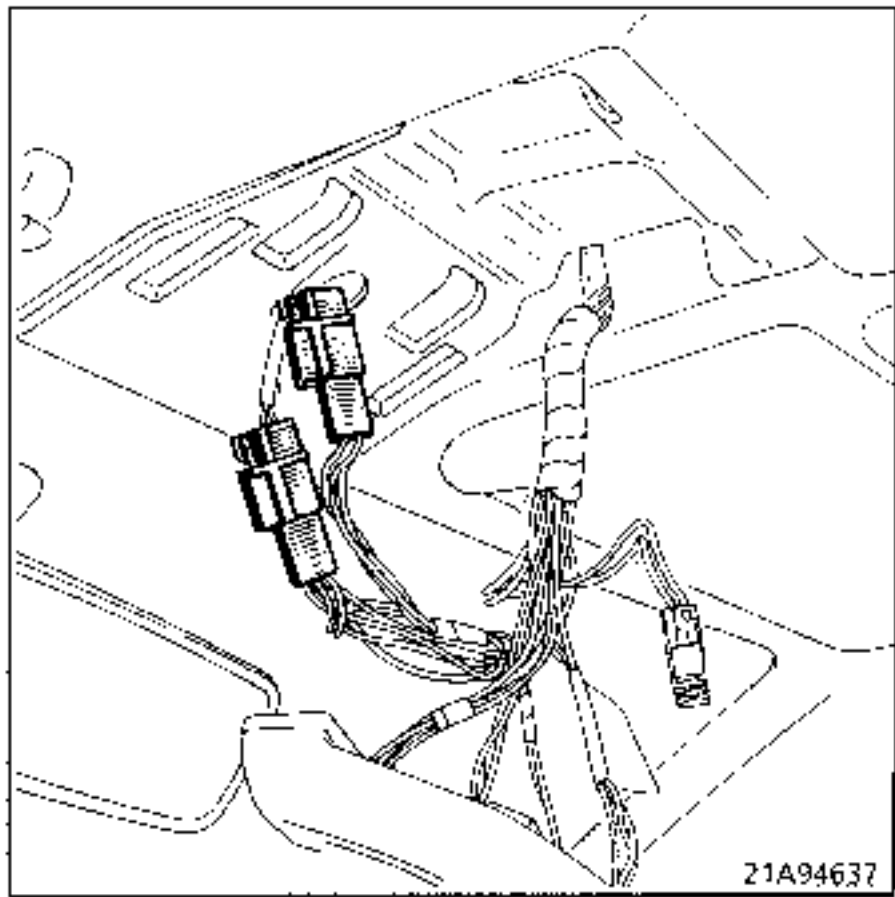

Disconnect the harness for the sun visor concerned.

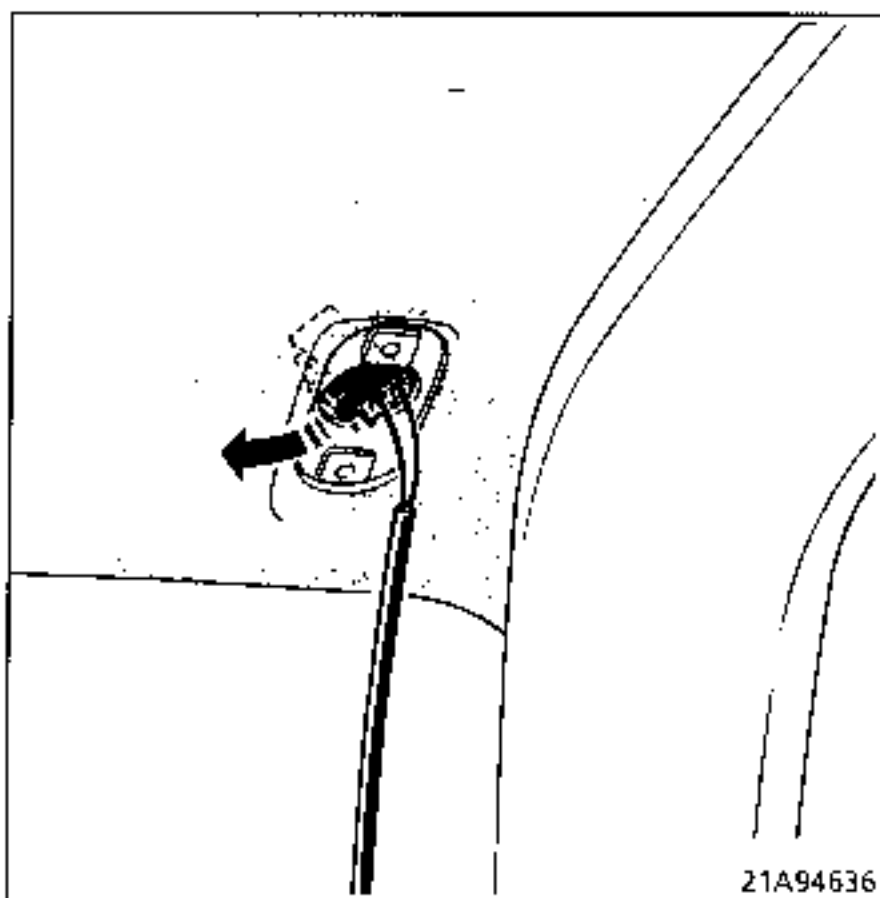

Remove the sun visor screws.

Take out the connector from the position shown above.

Sun visor bulbs

REMOVING A BULB

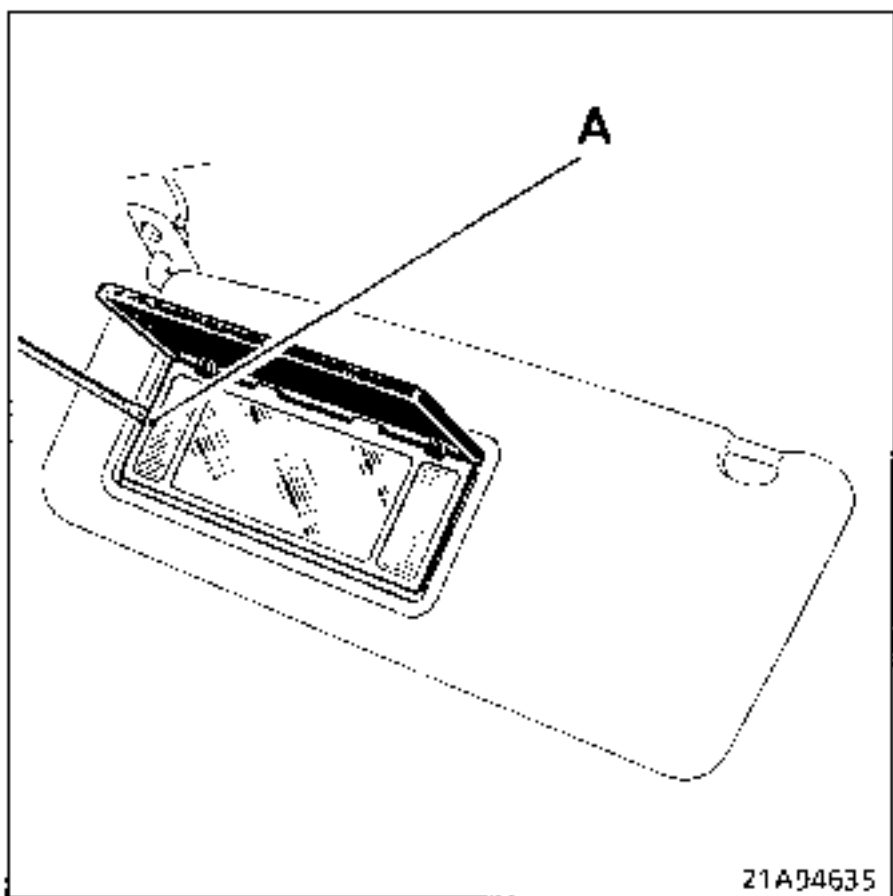

Open the courtesy mirror cover.

Unclip the sides of the mirror assembly (A).

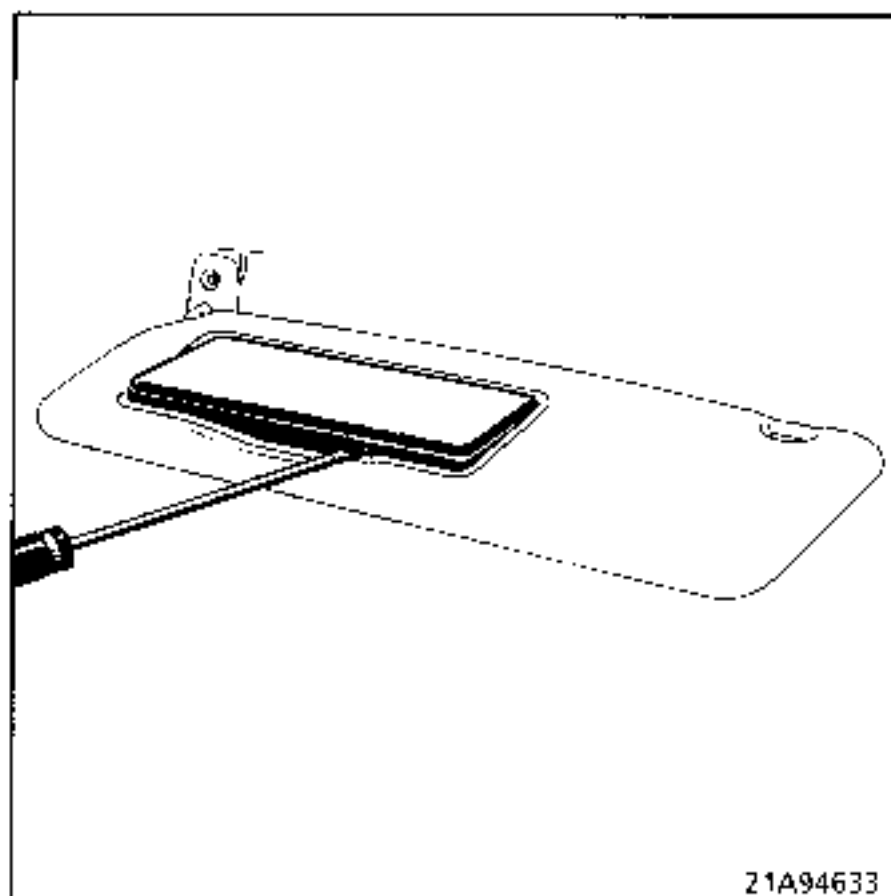

Close the mirror cover back down to prevent the springs from falling out.

Finish unclipping the assembly.

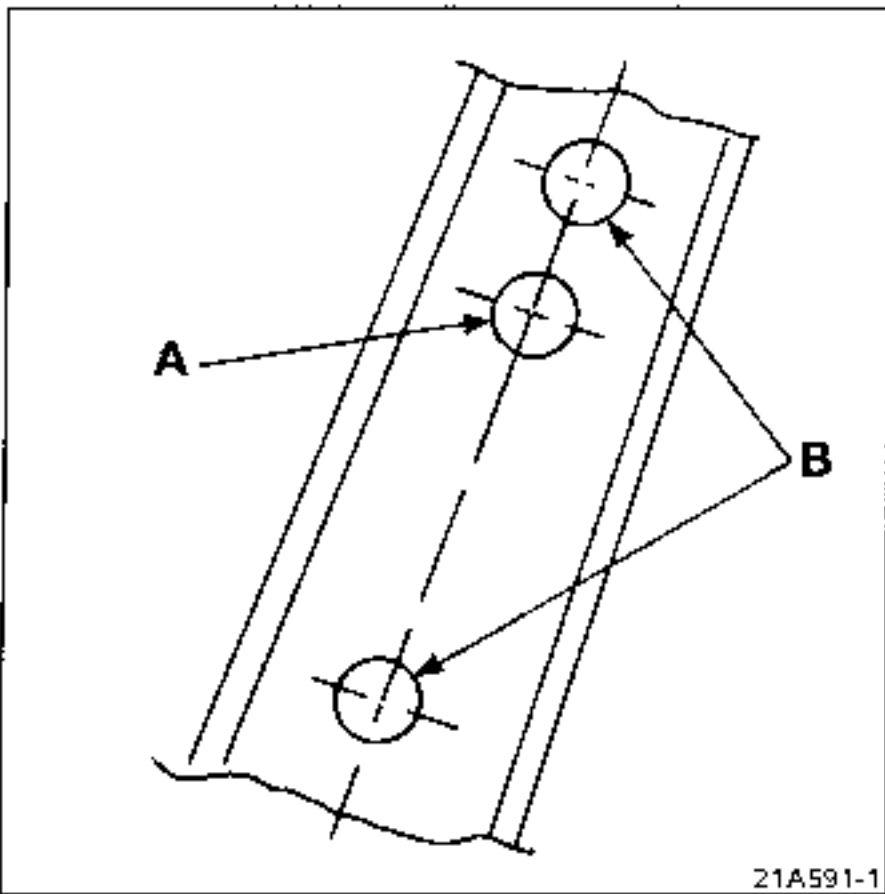

ATTENTION

(A) : X48 phase 1

"Only anchorage point for seat belt which may be used to secure a fixed mounting".

(B) : X48 phase 2

"These two anchorage points for the seat belts are reserved exclusively for fitting the adjustable seat belt system".

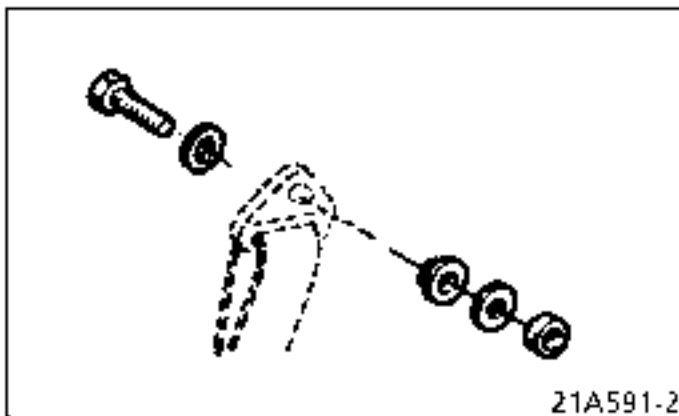

← Seat belt with fixed mounting.

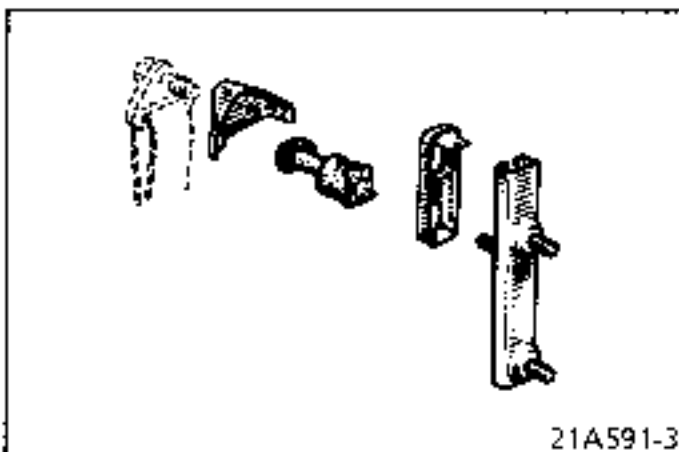

← Seat belt with height adjustable mounting.

In service exchange, the Parts Department only supplies centre pillars comprising three nuts for securing the safety belts.

IMPORTANT :

When replacing a centre pillar on vehicles equipped with safety belts having fixed shoulder strap mountings (eg- X48 phase 1), it is essential to mount the safety belt as it was originally mounted on the pillar (see diagram above).

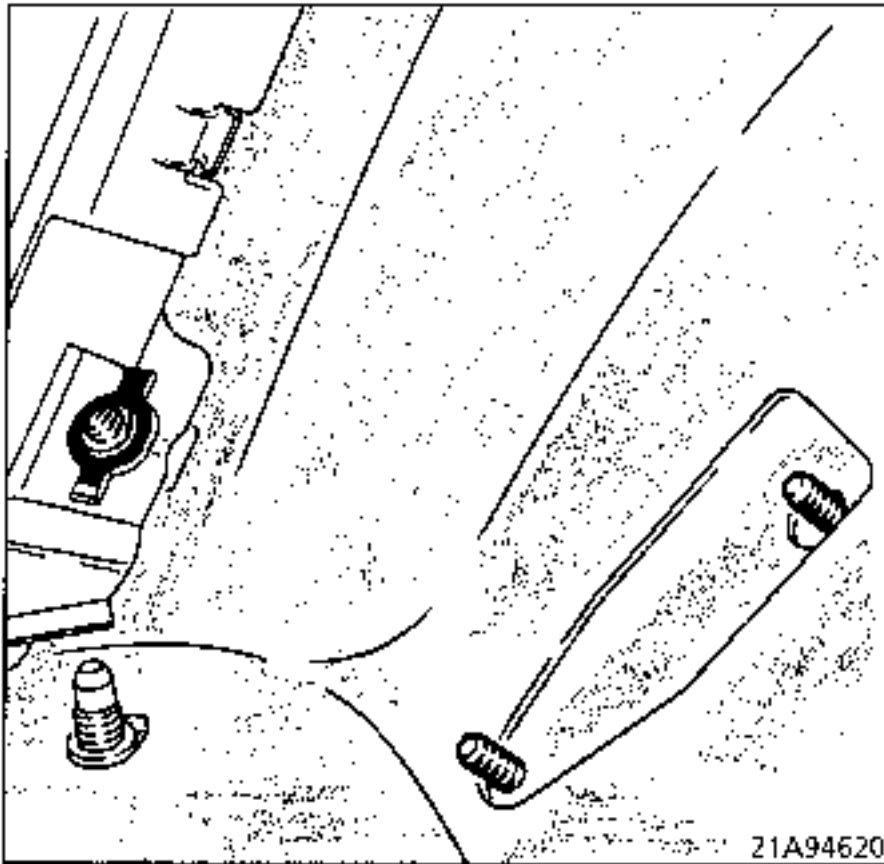

Remove the lower securing bolts on the body..

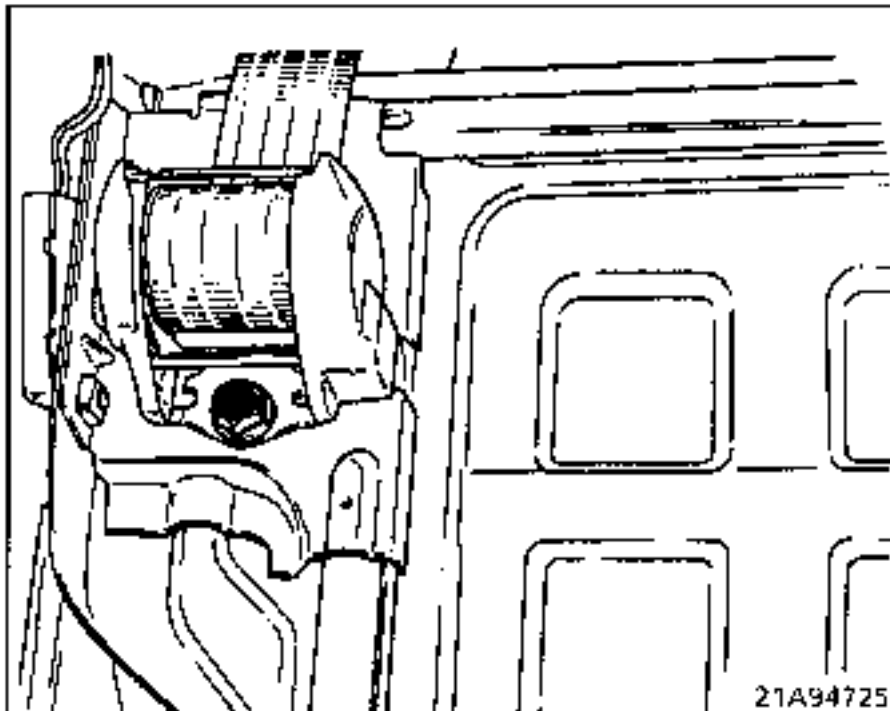

After removing the seat back trim, remove the seat belt mounting.