

VEHICLE TYPE	MECHANISM	DISC
--------------	-----------	------

B-L-K 48D

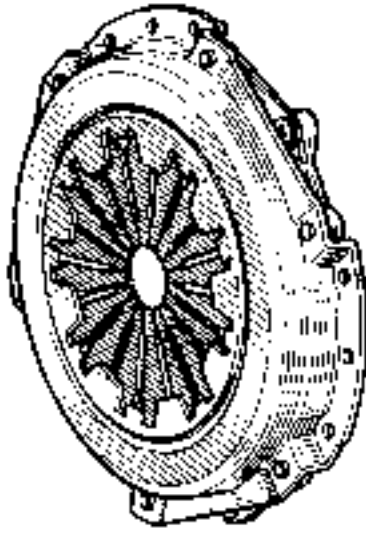

858735

180 CP 3300

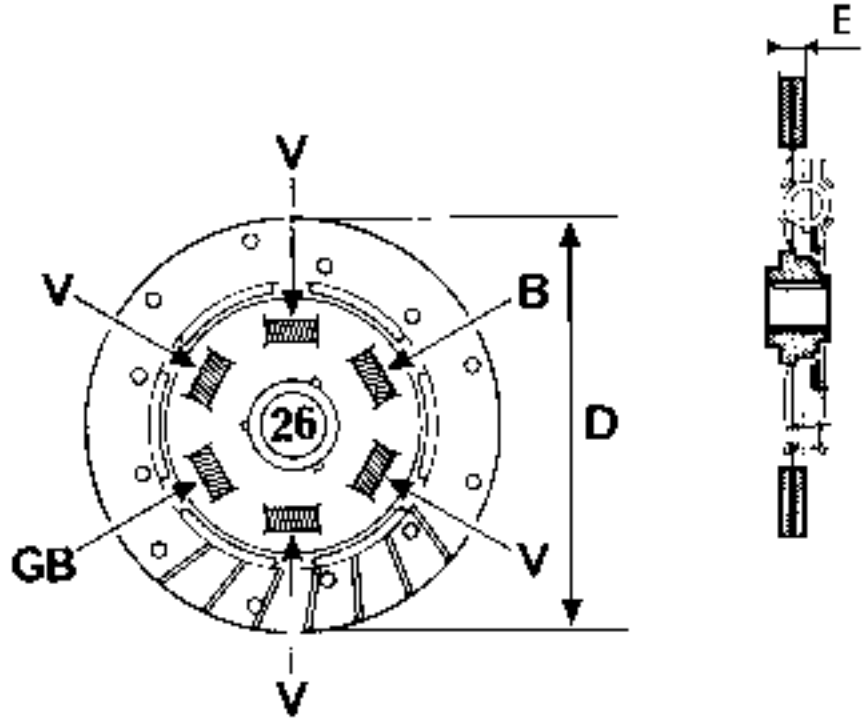

90693R

76905R

26 splines

E = 7.7 mm

D = 181.5 mm

B = White

GB = Blue grey

V = Green

B-L-K-S 481
B-L-K-S 482
B-L-K 48E
B-L-K 48F
B-L-K 48J
L-K 48M
L-K 48N

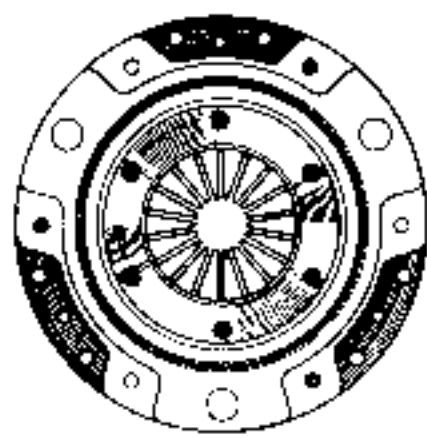

769075

200 CP 425
or
200 CP 4000

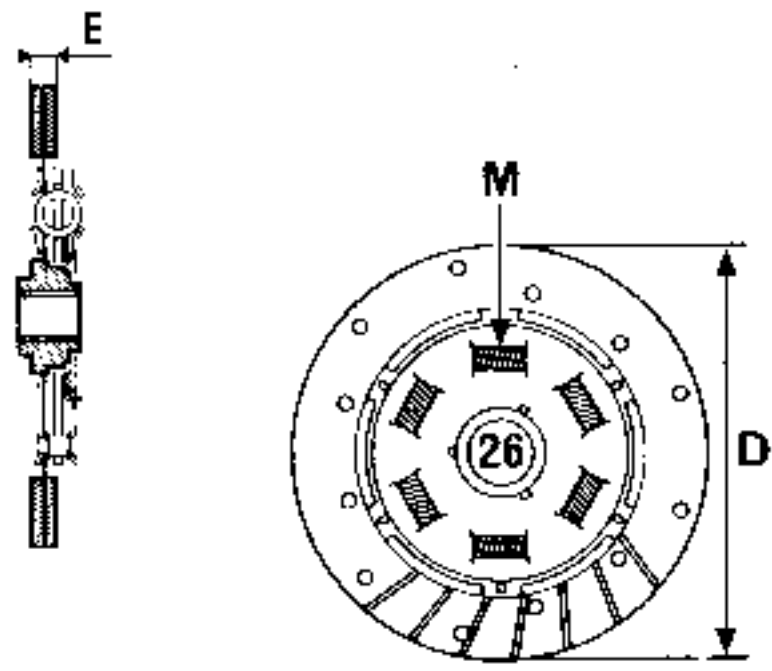

76906R



90693R1

26 splines

M = 6 light pink springs

E = 7.7 mm

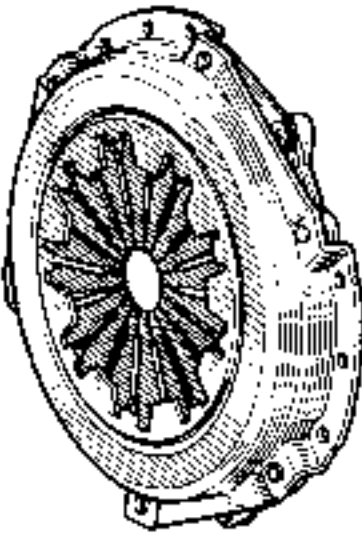
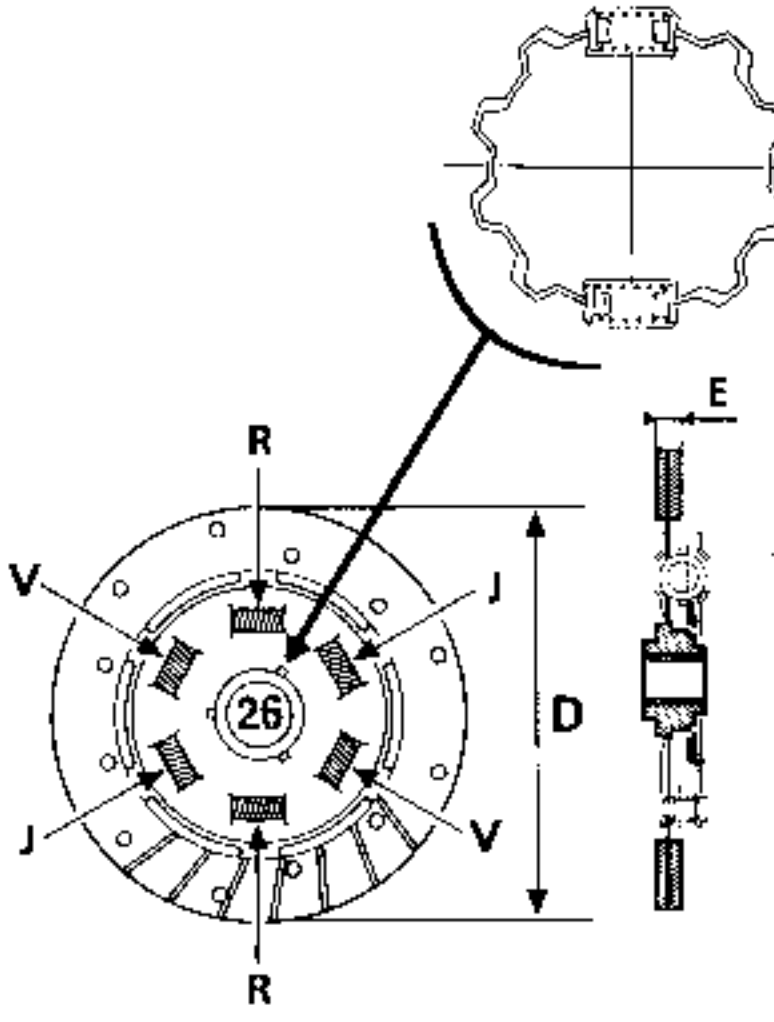
D = 200 mm

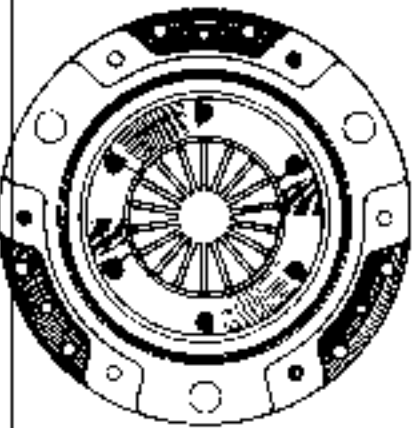
VEHICLE TYPE	ENGINE TYPE	FLYWHEEL PROFILE	MECHANISM	DISC
B-L-K-5 48H	F8Q	 <p>937275</p>	 <p>858735</p> <p>200 CP 4000</p>	<p>Special note: 2 additional springs on hub</p>  <p>90693G1</p> <p>76906R</p>
		 <p>937285</p>	 <p>769075</p> <p>200 CPV 3500</p>	<p>26 splines E = 7.7 mm D = 200 mm</p> <p>R = Red J = Yellow V = Green</p>

IMPORTANT

Special features of "diesel" clutch discs :

These are fitted with a damping pre-hub, the efficiency of which is best when its internal components operate dry.

If there is an excess of grease on the hub and this penetrates into the damper pre-hub it will render the hub less efficient and gearbox noise will occur.

VEHICLE TYPE

MECHANISM

DISC

B-L-K 486
B-L-K-S 48V

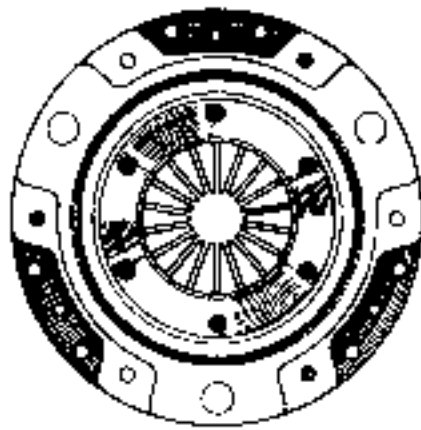

769075

200 CP 375
200 CP 3500

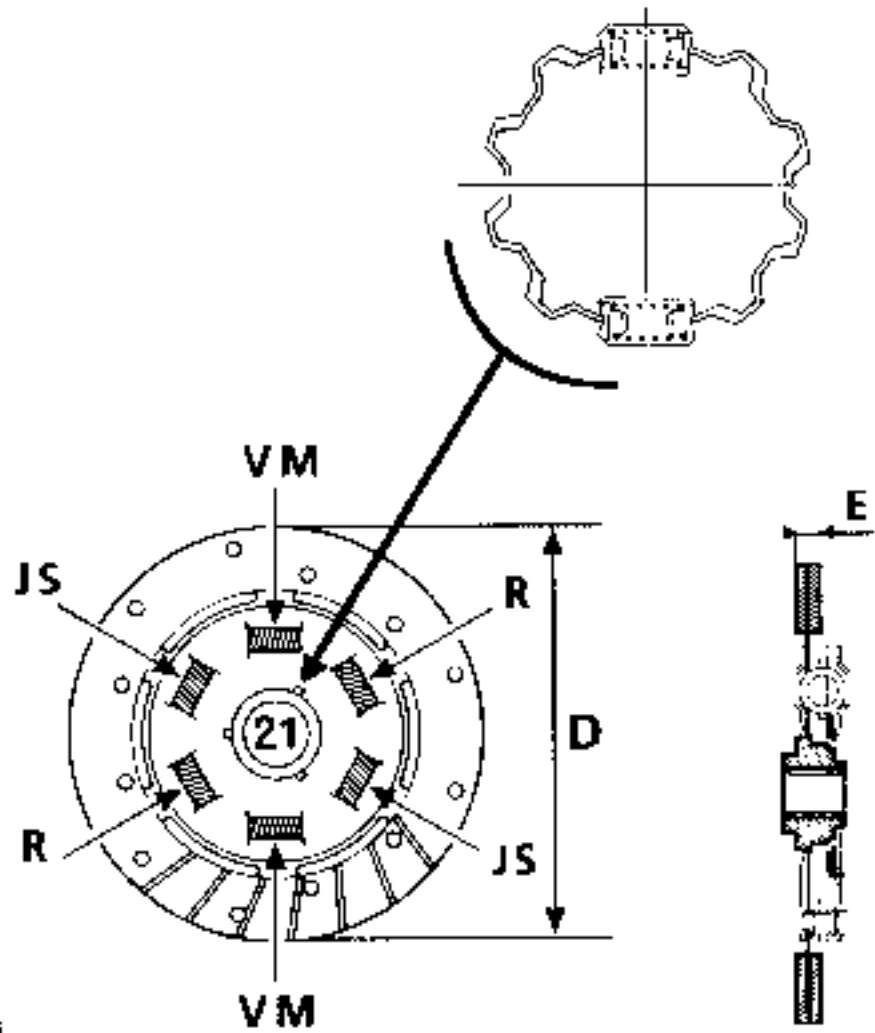

90693G2

21 splines

E = 7.7 mm

D = 200 mm

76906R

JS = Sand yellow

VM = Moss green

R = Red

B-L-K 488
B L K 48W

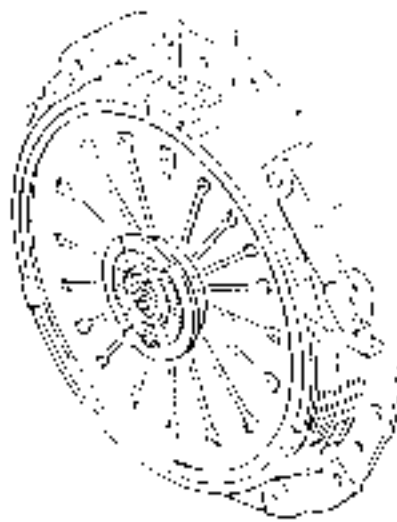

21203

215 DT 4900



76906R

21 splines

E = 6.8 mm

D = 215 mm

BC = Light blue

GB = Blue grey

J = Yellow

VEHICLE TYPE

MECHANISM

DISC

4 × 2

1st assembly

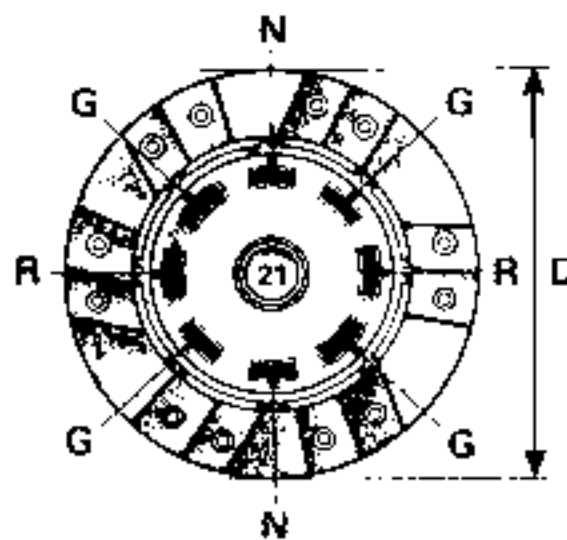

2182168 1

21 splines
E = 6.8 mm
D = 215 mm

G = Grey
N = Black
R = Red

2nd assembly



76906R

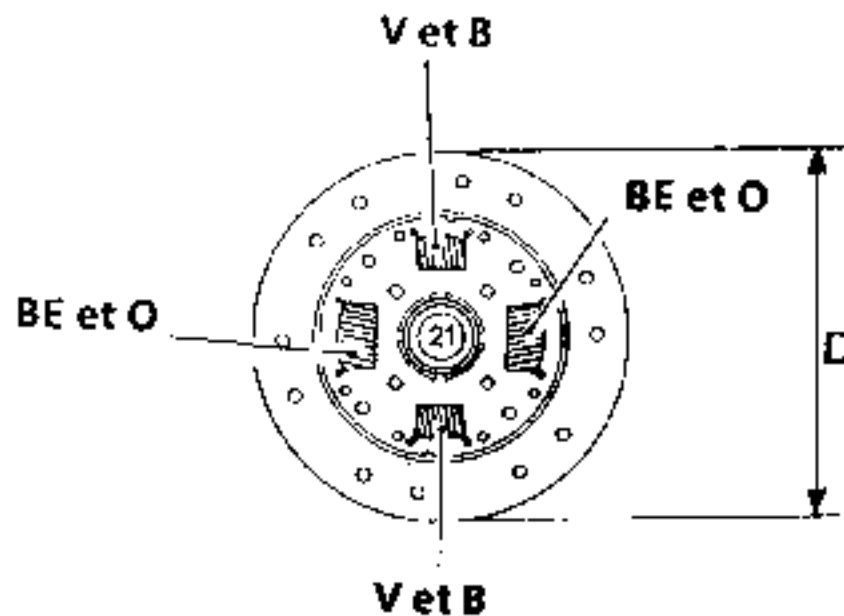

2190693-1

21 splines
E = 6.8 mm
D = 215 mm
V = Green
B = Blue
BE = Beige
O = Orange

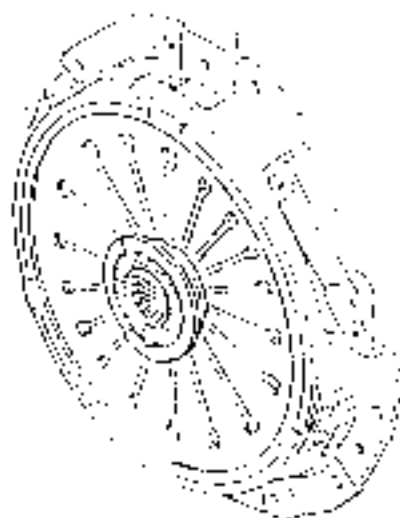

21703

215 DT 475

or

215 DT 4900

B-L-K 48K
B-L 48Q
B-L 48R
B-L 48Y
B-K-L 483
L 489

VEHICLE TYPE

MECHANISM

DISC

4 × 2

1st assembly

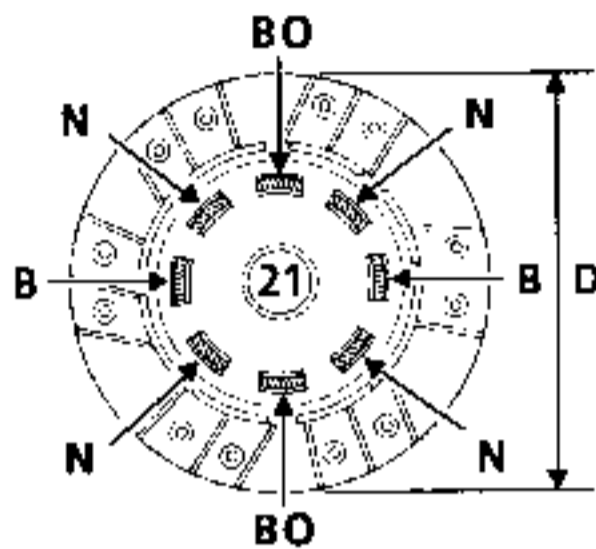

90693 1R5

21 splines

BO = Olive brown

E = 7.7 mm

N = Black

D = 228.6 mm

B = Blue

L485

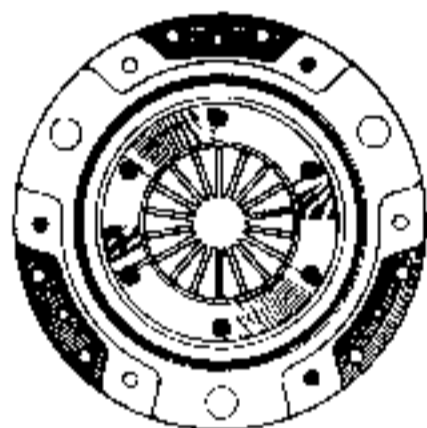

769075

235 CP 6250

2nd assembly

76906R

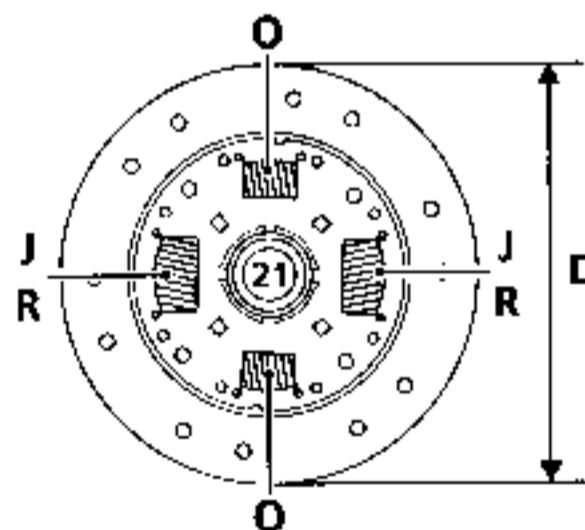

90693-2R5

21 splines

E = 7.7 mm

D = 228.6 mm

J = Yellow

R = Red

O = Orange

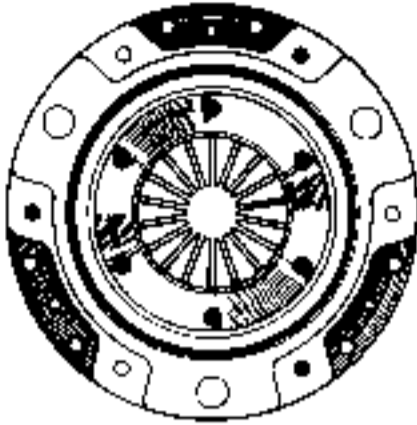
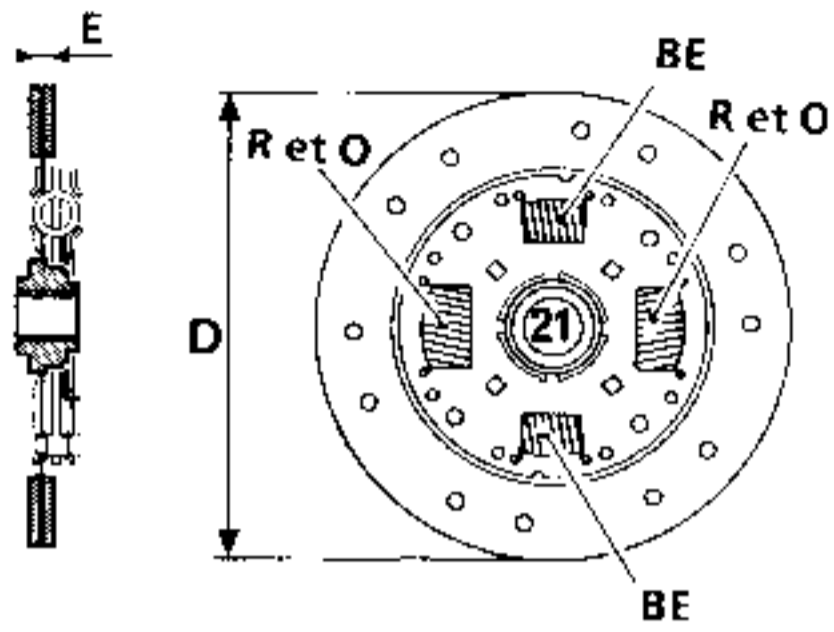
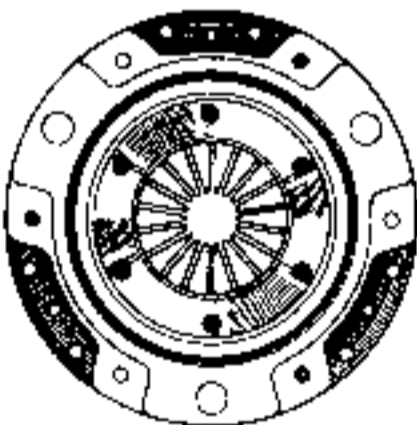
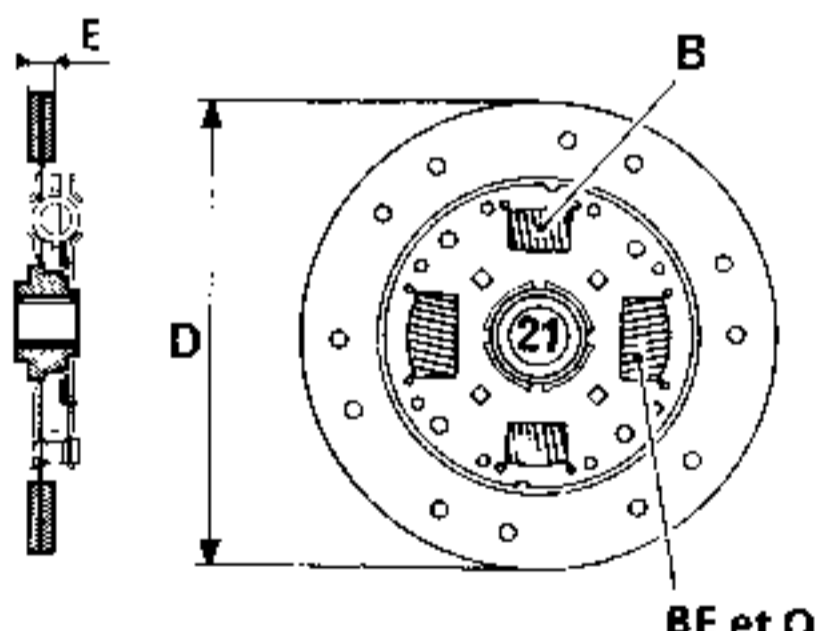
VEHICLE TYPE	MECHANISM	DISC
<p>4 x 4</p> <p>B-L 48R B-L 48Y</p>	 <p>769075</p> <p>215 CP 4500</p>	 <p>76906R</p> <p>2190693-4</p> <p>21 splines E = 6.8 mm D = 215 mm</p> <p>BE = Beige O = Orange R = Red</p>
<p>4 x 4</p> <p>L 485</p>	 <p>769075</p> <p>235 CP 6250</p>	 <p>76906R</p> <p>2190693-5</p> <p>21 splines E = 7.7 mm D = 228.6 mm</p> <p>B = Blue BE = Beige O = Orange</p>

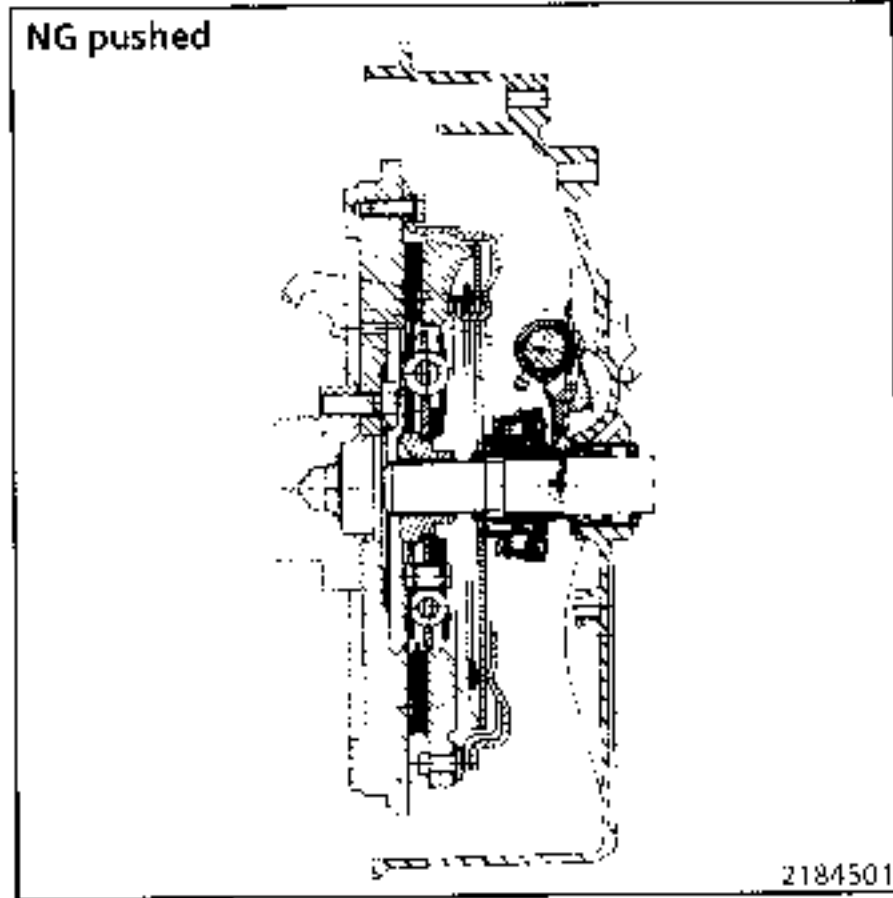
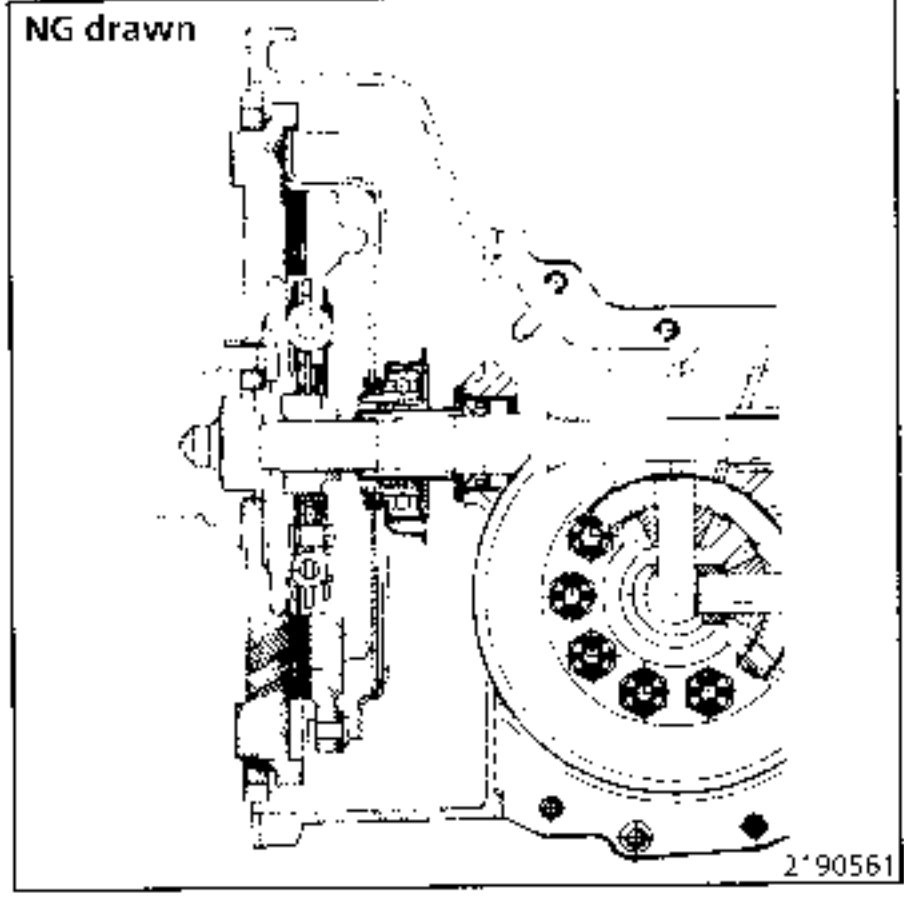
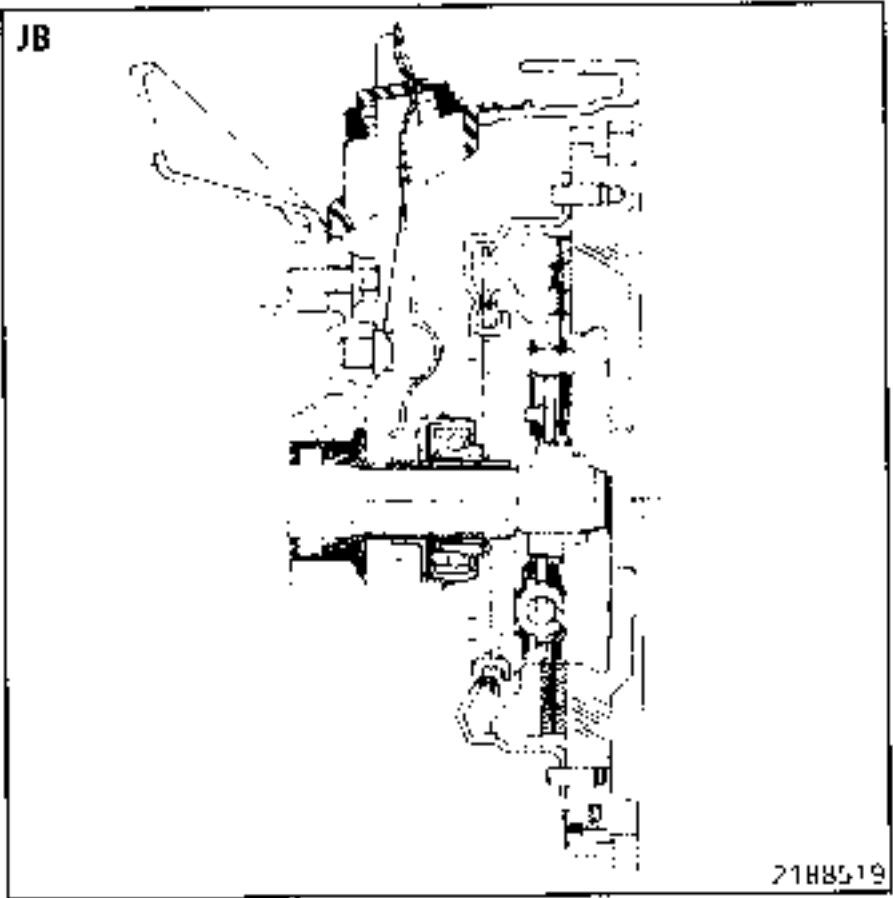

Single disc, cable controlled disc, operating dry.
Clutch plate with diaphragm.
Clutch disc with resilient hub.

"Pushed" type clutch:

Self-centring guided ball bearing type thrust pad in constant contact.

"Drawn" type clutch:

Ball bearing type thrust pad integral with diaphragm.

Automatic wear take-up.

UN

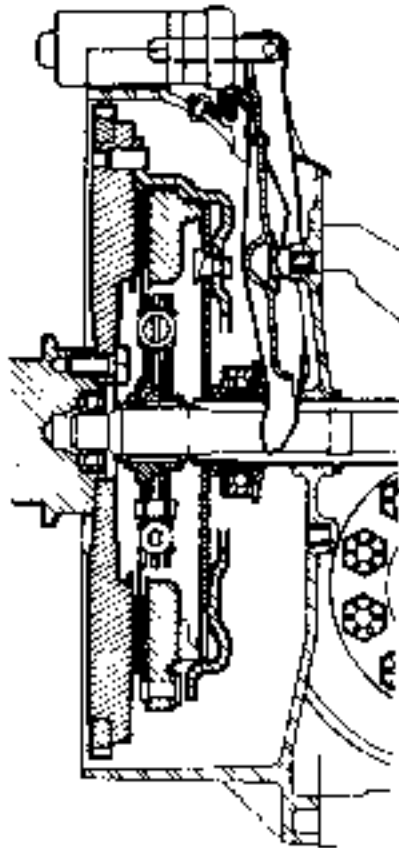

2177392

Single disc clutch operating dry.

Clutch plate with diaphragm.

Clutch disc with resilient hub.

Self-centring guided ball bearing type thrust pad in constant contact.

Mechanically assisted clutch control.

Hydraulic control:

- The principle of this control is the same as for a brake control.
- The clutch pedal acts on a master cylinder which causes the slave cylinder piston to move and act on the fork.

Clearance can not be adjusted at the pedal.

BENDIX control :

- The hydraulic circuit is supplied with the fluid contained in the brake fluid reservoir.

"Automotive Products" control:

- The fluid reservoir is integral with the master cylinder.
- This equipment is supplied ready filled and bled.

Hydraulic clutch controls

BENDIX

TIGHTENING TORQUES IN daN.m

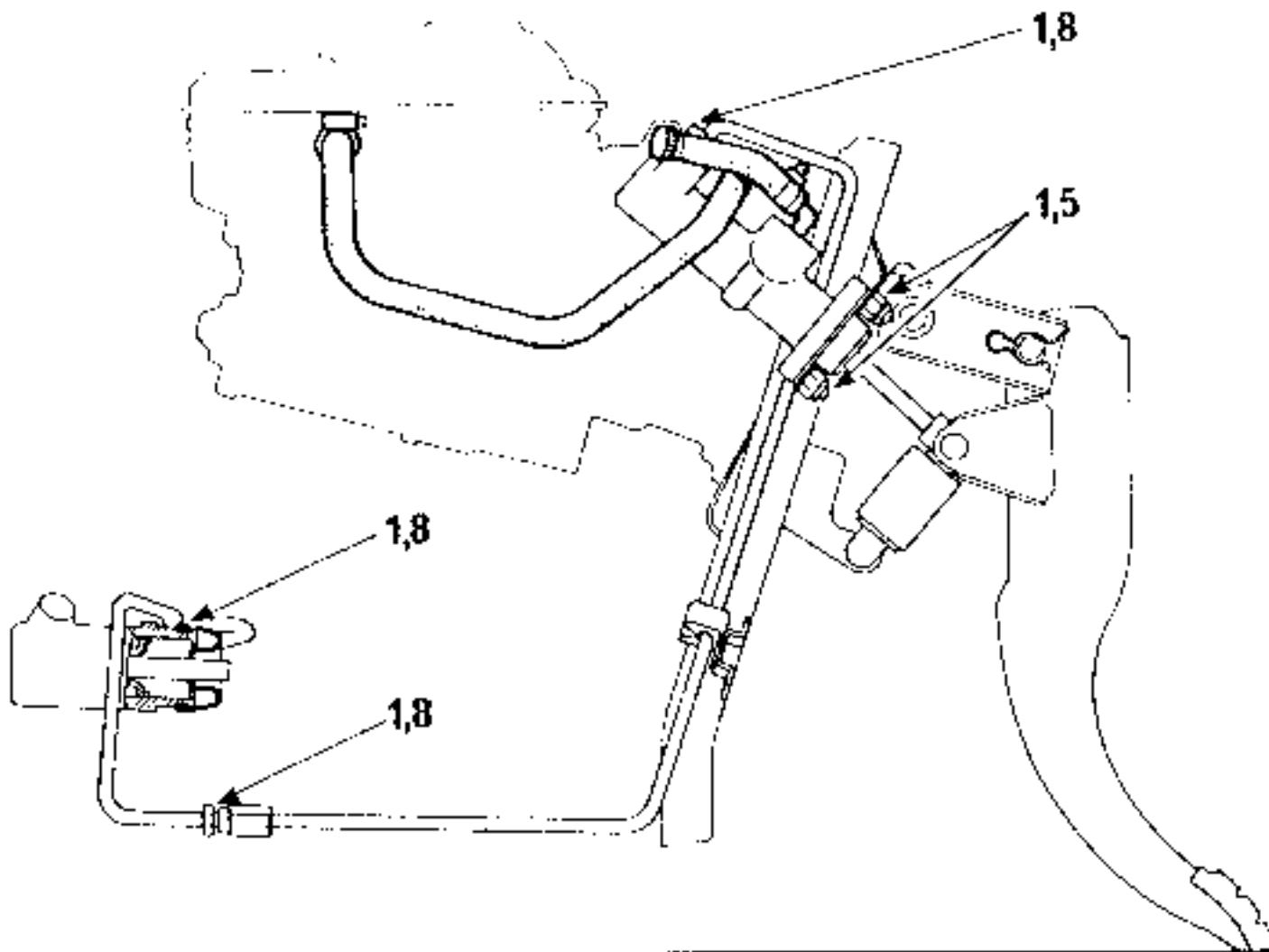

7191578

AUTOMOTIVE PRODUCTS

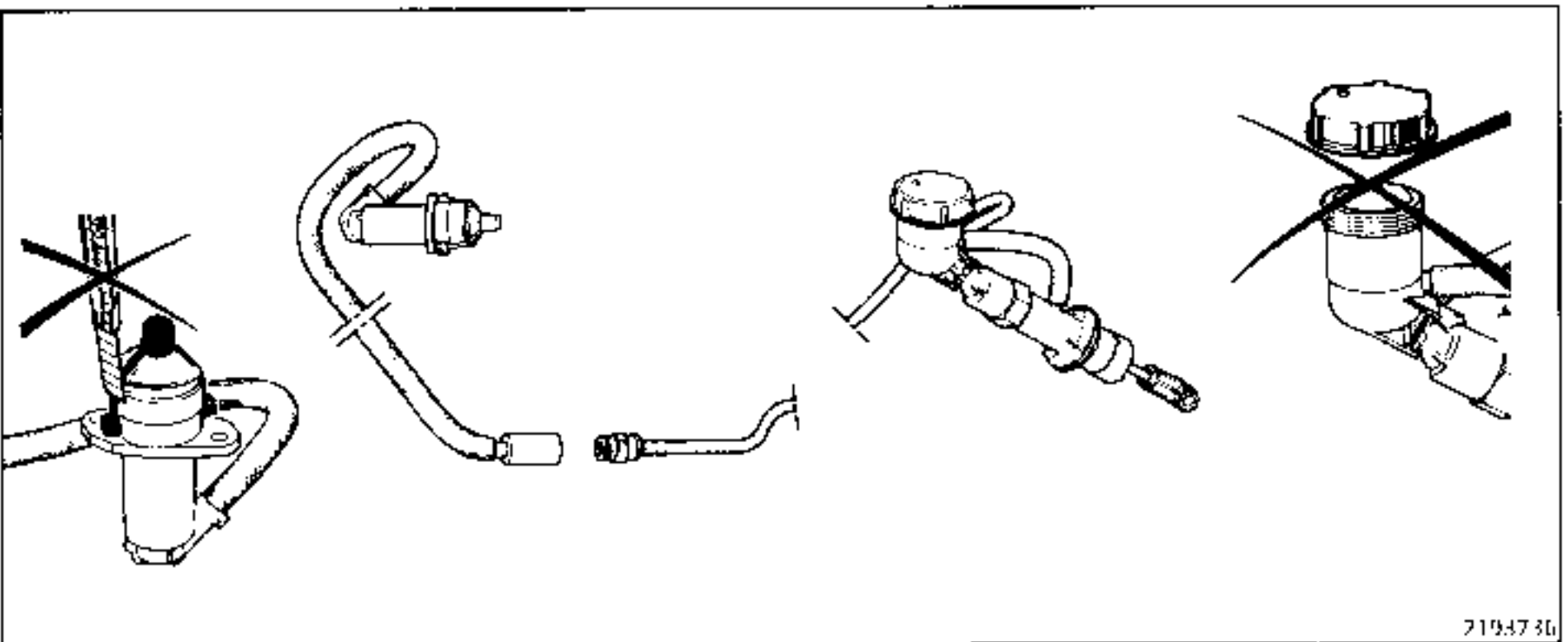

7193736

AP control - Special notes: This equipment is supplied ready filled and bled.

- The master cylinder is mounted using a bayonet type mounting.
- The slave cylinder push rod is held in its initial position by two tabs which divide the first time the pedal is pressed.

Refer to section 37.

"PUSHED" TYPE CLUTCH (JB gearbox)

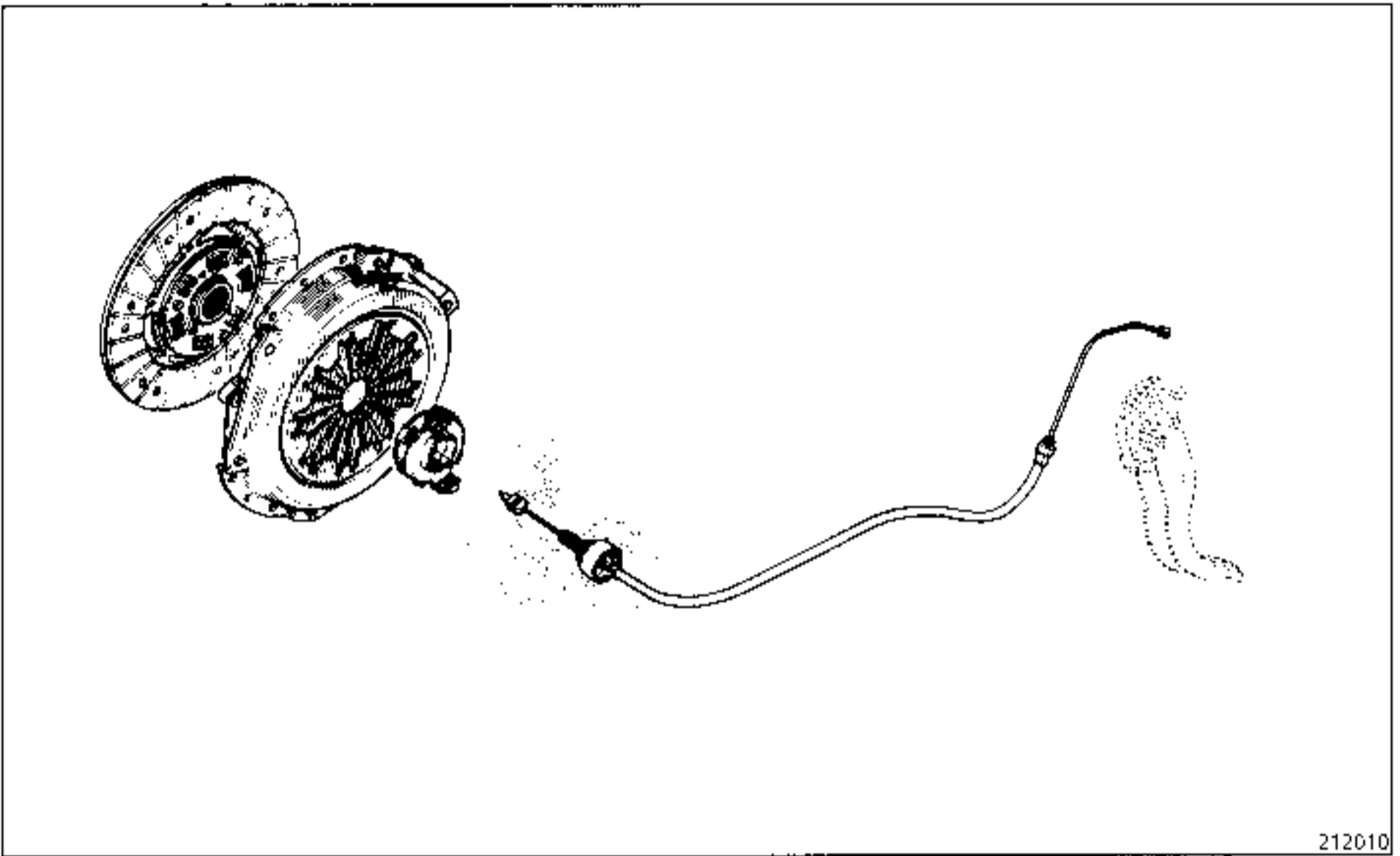

212010

"PUSHED" TYPE CLUTCH (NG gearbox)

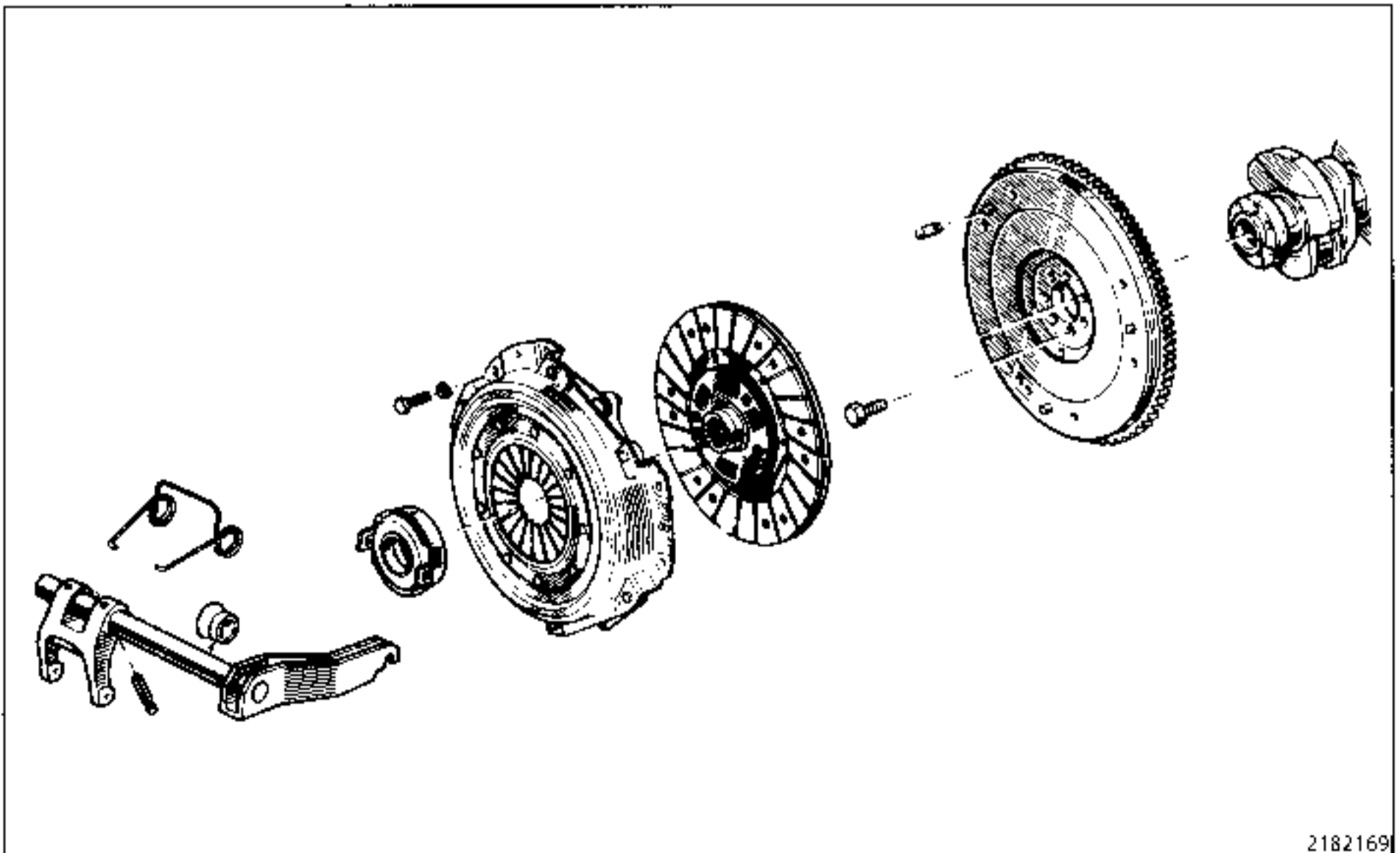

2182169

"PUSHED" TYPE CLUTCH (UN gearbox)

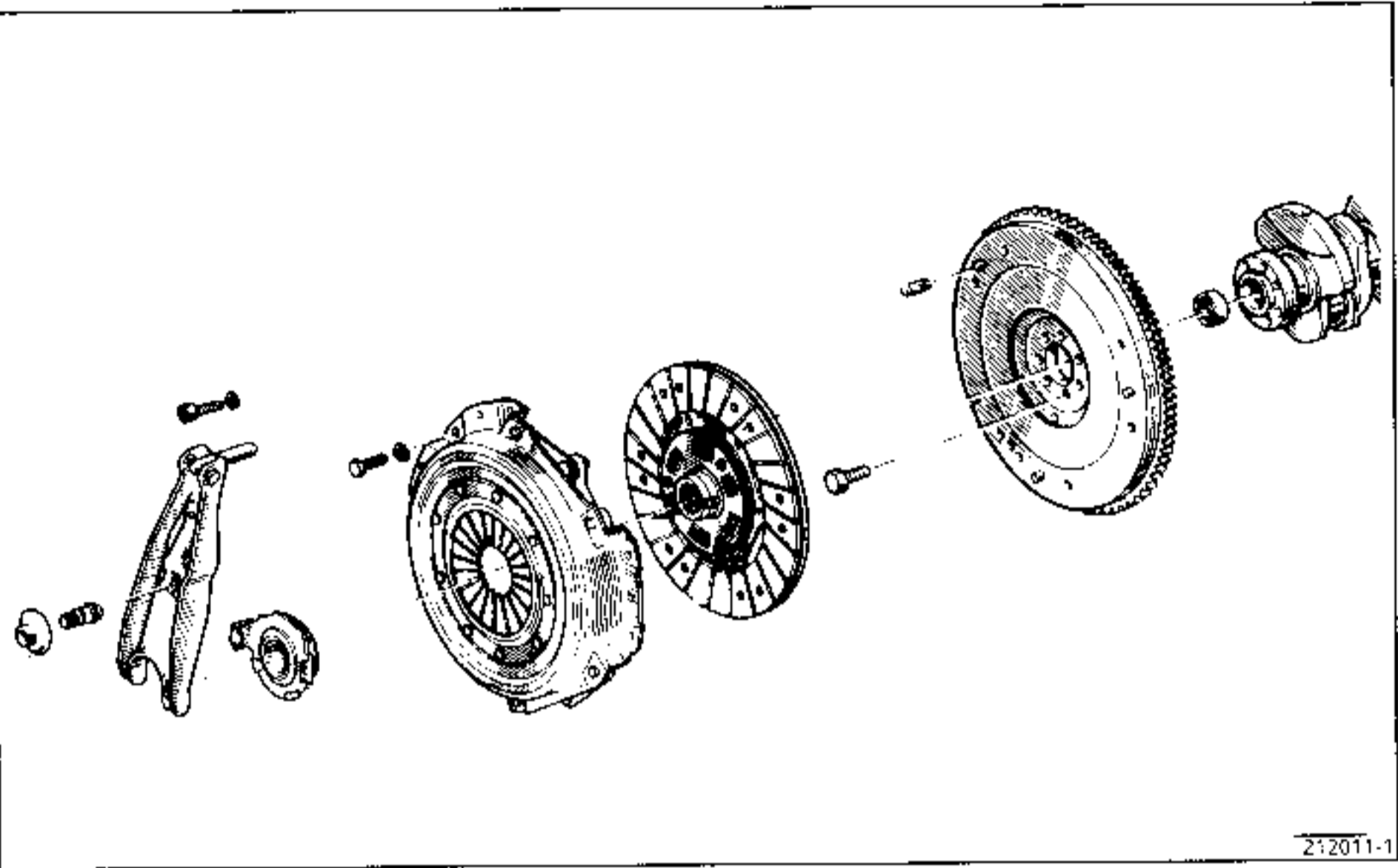

"DRAWN" TYPE CLUTCH (NG gearbox)

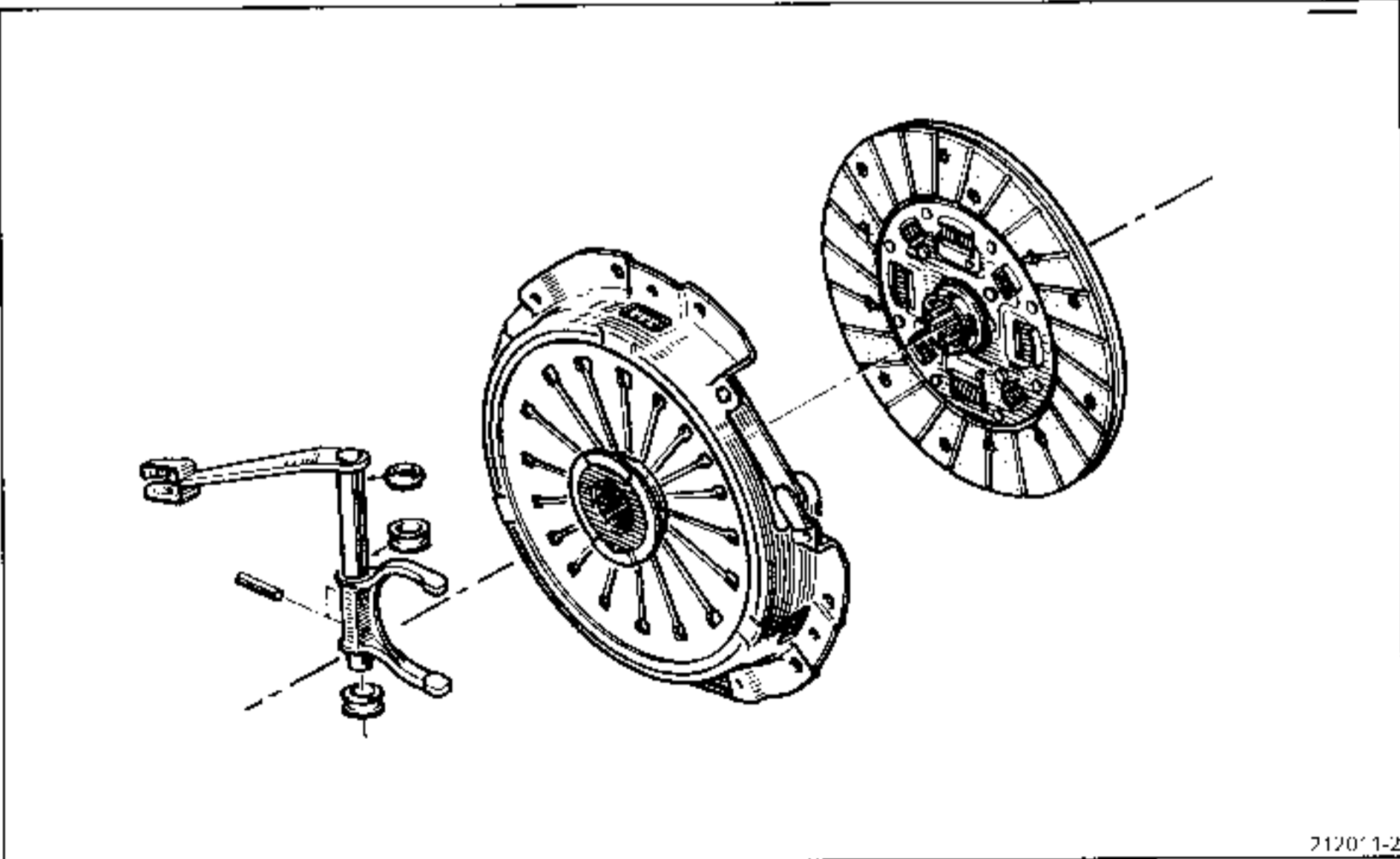

REPLACEMENT

This operation is carried out when the gearbox has been separated from the engine.

SPECIAL TOOLING REQUIRED	
Mot. 582	Locking tool

TIGHTENING TORQUES (in daN.m)		
7 mm diameter mechanism mounting bolt	2.5	
8 mm diameter mechanism mounting bolt	3	

REMOVAL

Fit the locking tool **Mot. 582**.

Remove the mounting bolts from the mechanism and remove the mechanism together with the clutch disc.

Check and replace any faulty parts.

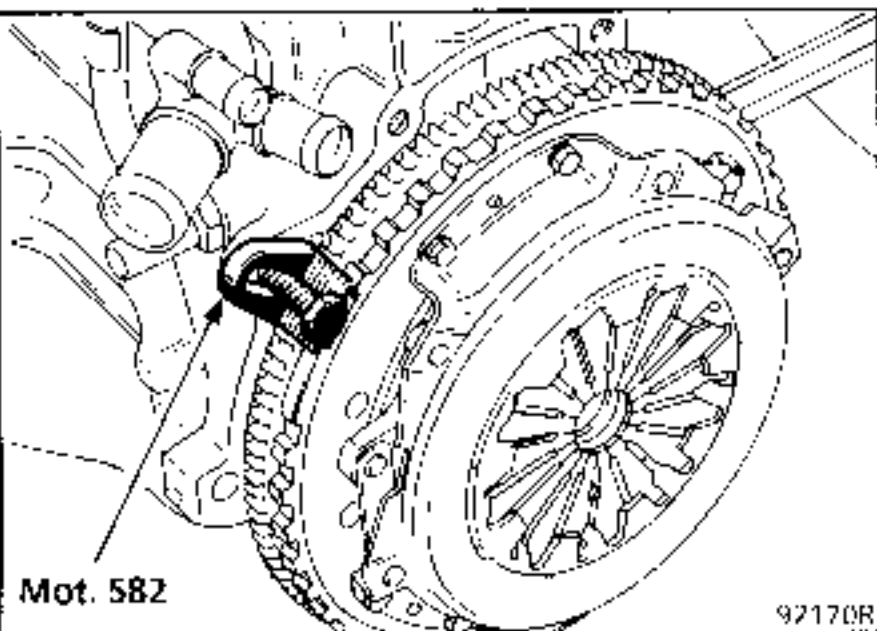

REFITTING

ALL TYPES

PRECAUTIONS TO BE TAKEN WHEN REPAIRING THE CLUTCH

To improve the sliding of clutch discs, the hubs are now nickel coated.

Clean the clutch shaft splines and refit the assembly, **without lubricant**.

Special notes for diesel engine clutch discs :

These are equipped with a damper pre hub which is most efficient when its internal components are operating dry.

Fit the disc into position: offset (A) of the hub should be at the gearbox end.

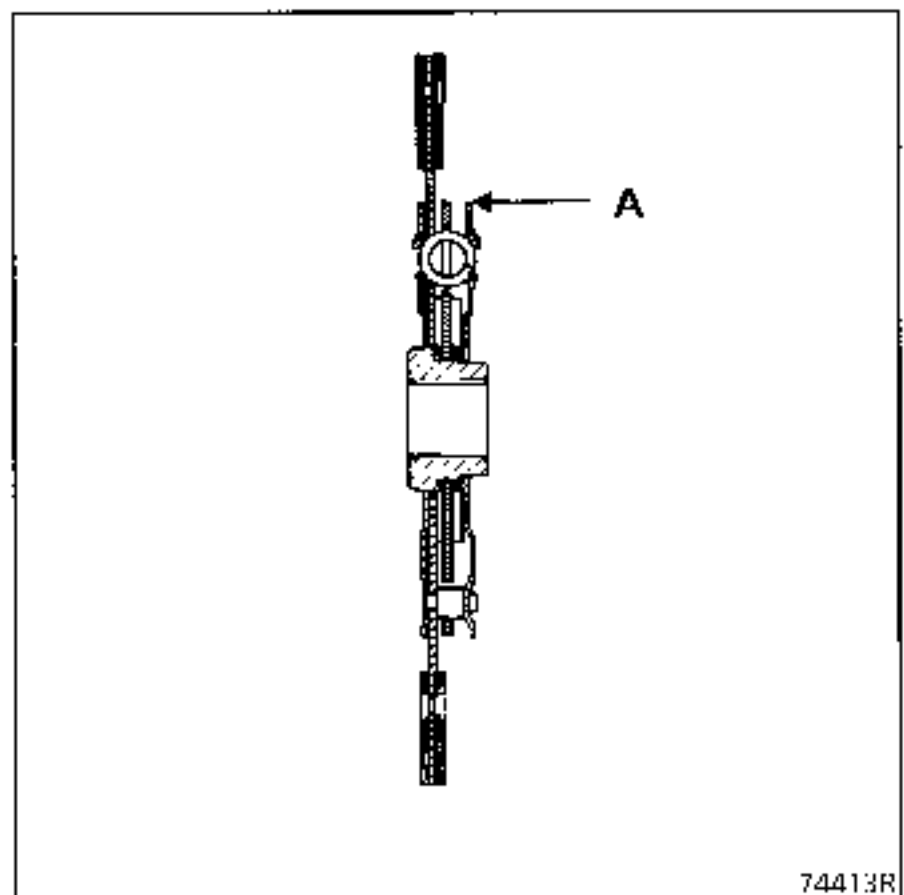

Use the plastic centring device provided in the kit to fit the disc.

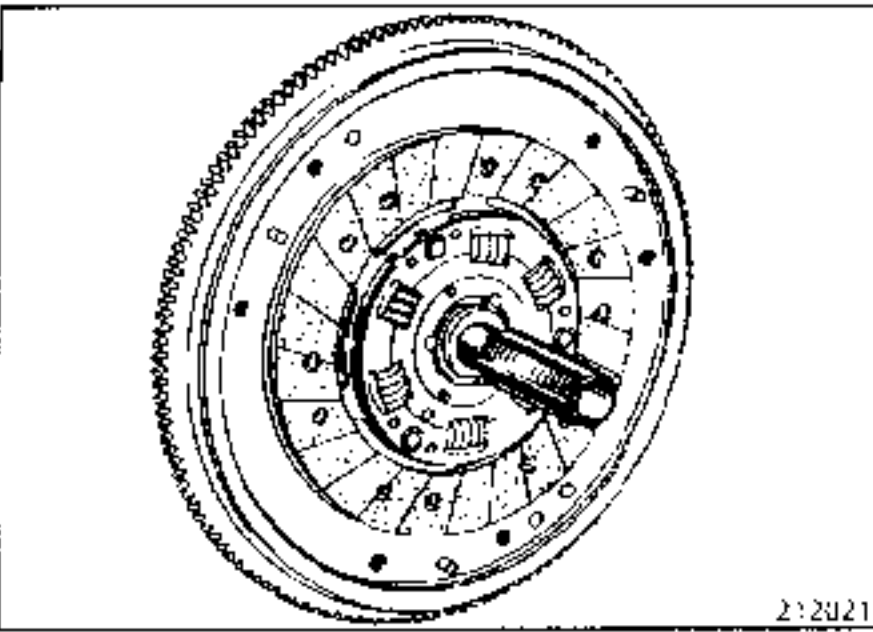

Fit the mechanism.

Gradually tighten then torque tighten the mechanism mounting bolts.

Remove the locking tool **Mat. 582**.

Coat the following components with **MOLYKOTE BR2** :

- thrust pad bore,
- guide tube,
- fork pads,
- pivot.

After refitting the gearbox, reset the toothed segment and check the automatic take-up system operates correctly (depending on version).

Check the fork travel . It should be :
X = 17 to 18 mm

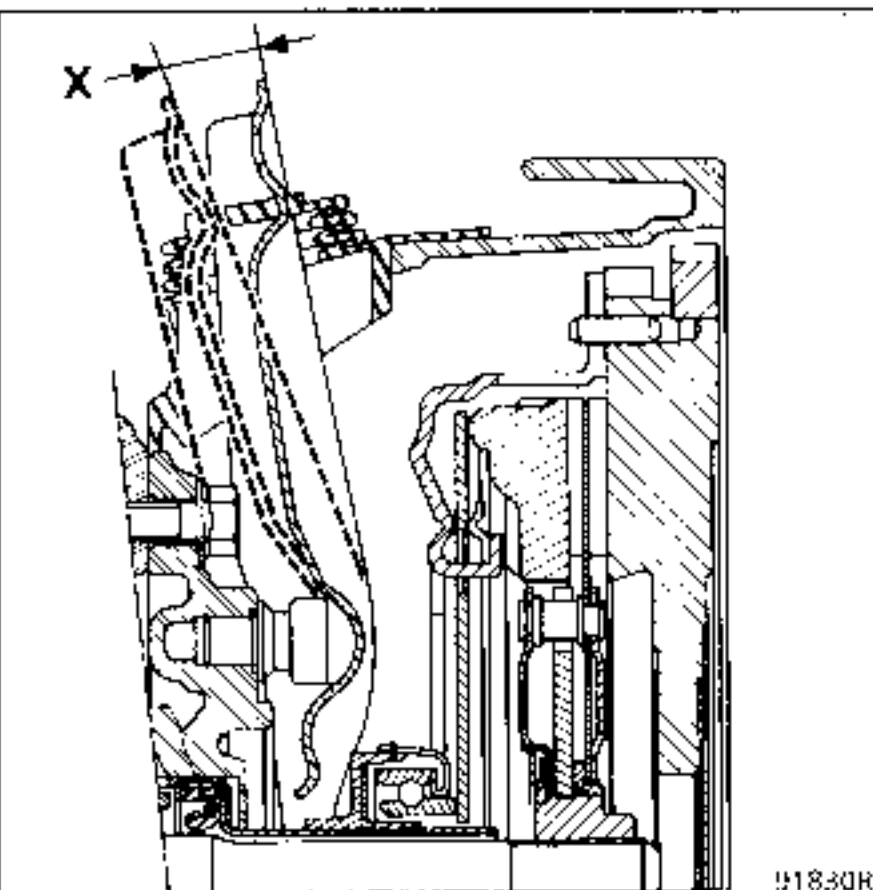

NOTE : to centre the disc on **J** and **F** engines, use the centring rings.

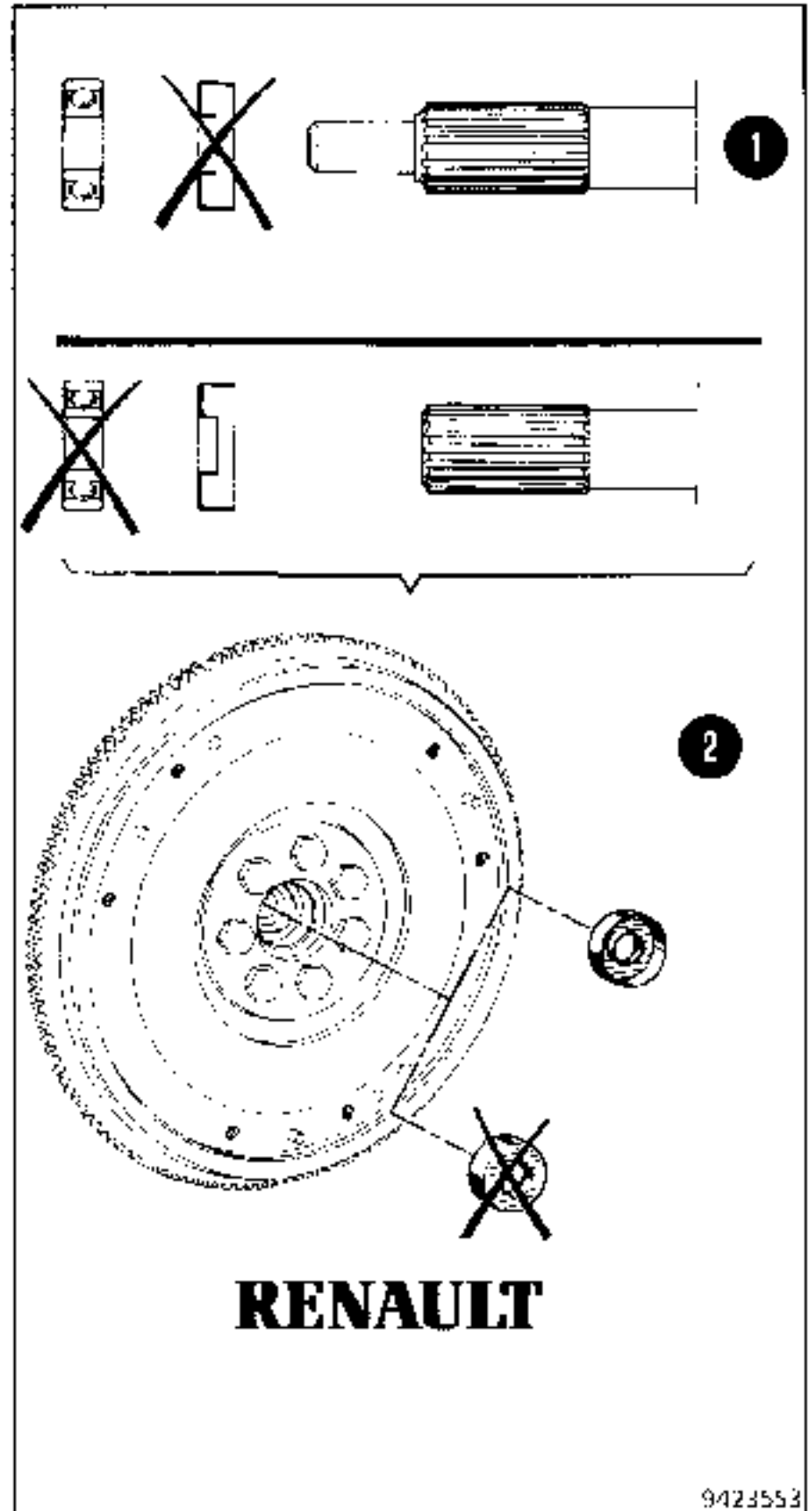

REPLACEMENT

This operation is carried out when the gearbox has been separated from the engine.

REMOVAL

Remove the thrust pad by tilting the fork.

Remove the rubber protector and pull the fork to the interior of the clutch bellhousing.

REFITTING

Coat the walls of the guide tube and the fork pads using **MOLYKOTE BR2**.

1st fitting

Position the fork by placing the spring (1) behind the cup (2) on the pivot.

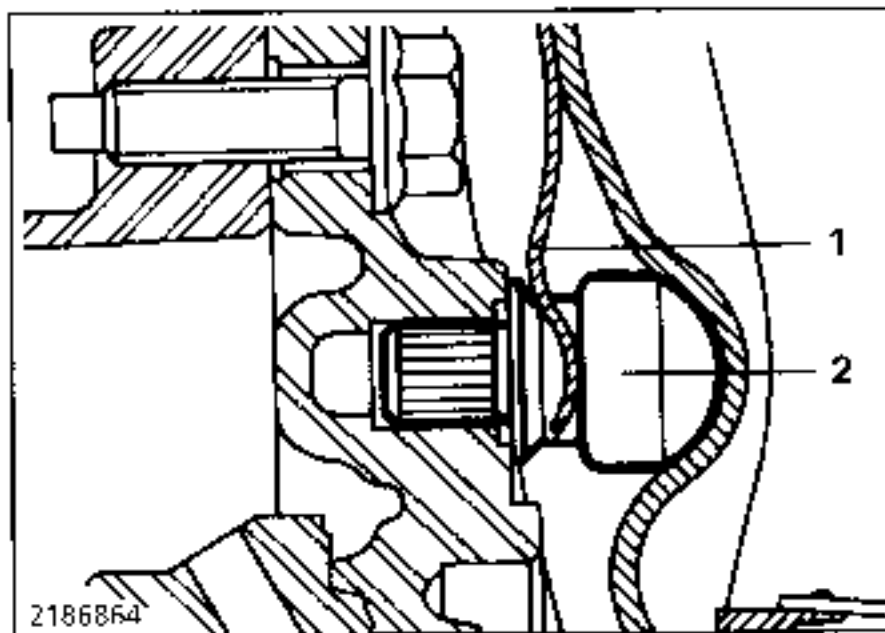
**2nd fitting**

There is no clutch fork thrust spring (1) on the pivot.

Place the thrust pad on the guide tube, placing clip (B) in the fork.

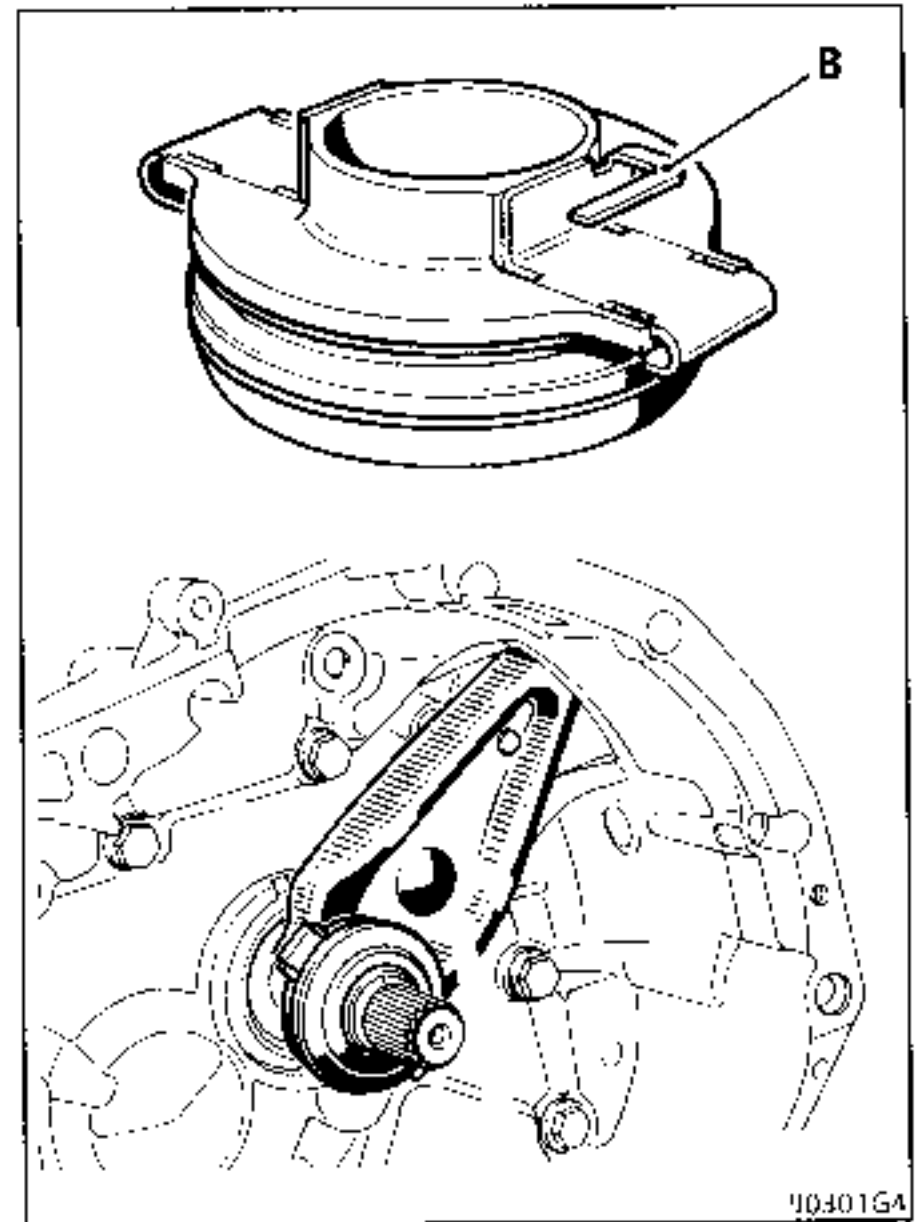

Refit the rubber protector.

Ensure the assembly operates correctly.

NOTE : when carrying out operations which do not require the gearbox to be removed or after replacing the gearbox, **DO NOT** lift the fork as this may release the clip (B) on the thrust pad.

REPLACEMENT

This operation is carried out when the gearbox has been separated from the engine.

THRUST PAD**Removal**

Tilt the fork to remove the thrust pad.

Refitting

Coat the walls of the guide tube with **MOLYKOTE BR2**.

Fit the thrust pad on the guide tube, inserting clip (A) into the fork.

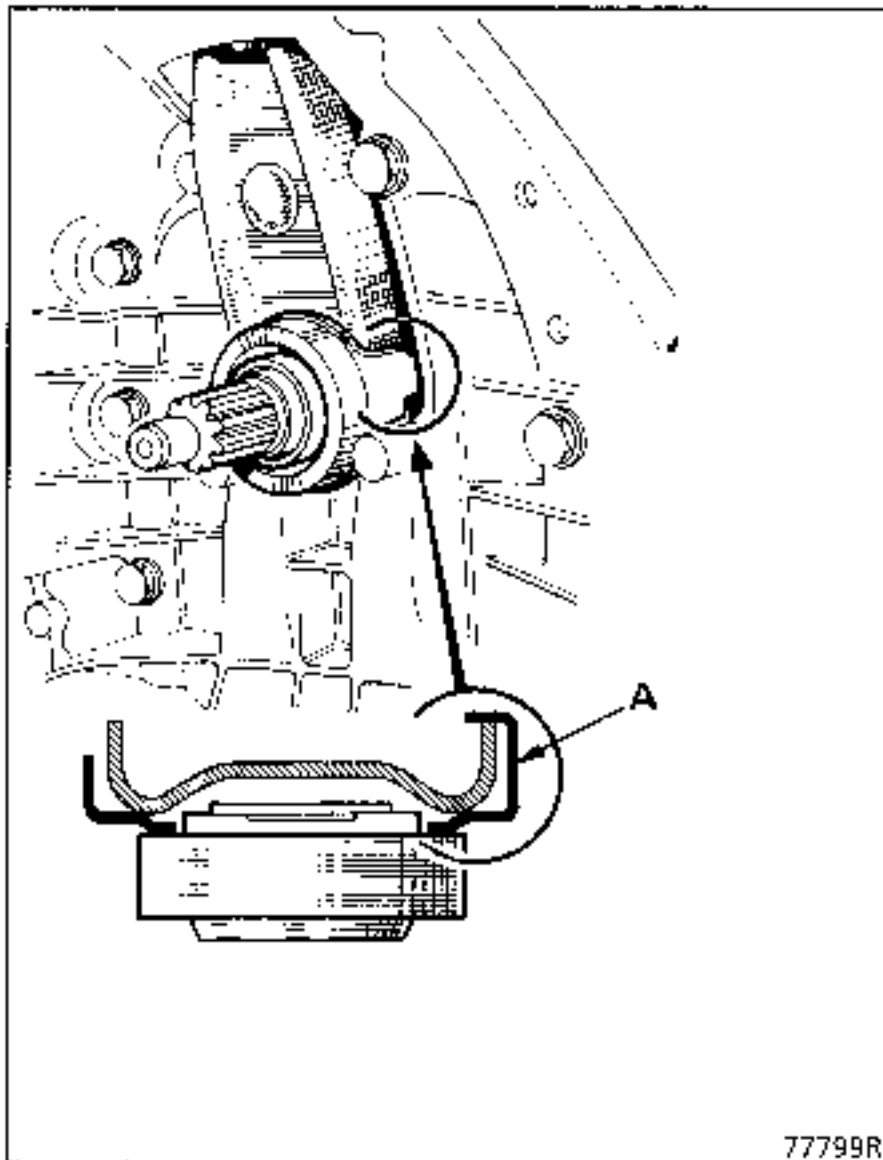

77799R

Ensure that it slides correctly.

FORK**Removal**

Pull the fork towards the outside of the gearbox to remove it.

Refitting

Lightly coat the fork pivot with "MOLYKOTE BR2".

Fit the fork into position, positioning spring (1) behind cup (2).

Ensure the assembly operates correctly.

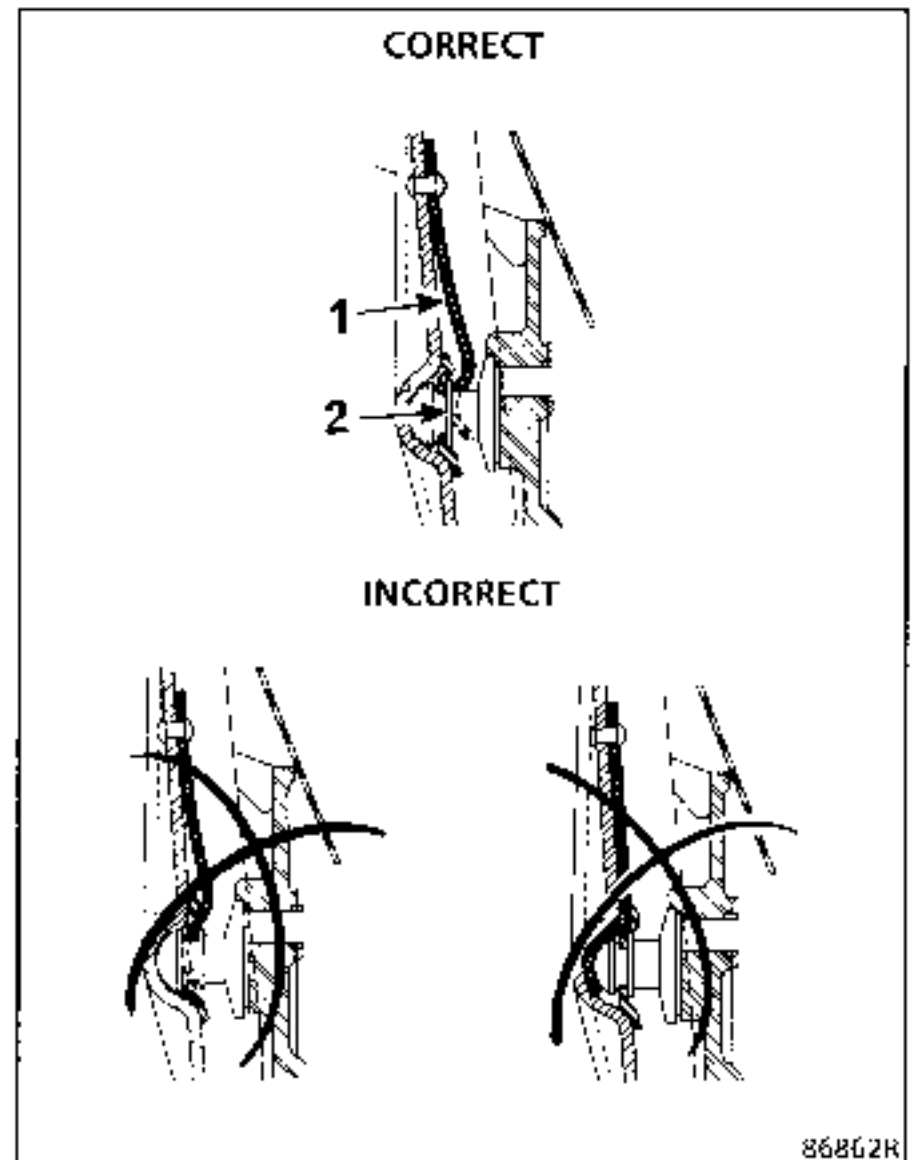

86862R

REPLACEMENT

SPECIAL TOOLING REQUIRED	
Emb. 880	Roll pin extractor

This operation is carried out when the gearbox has been separated from the engine.

REMOVAL

Remove the roll pins from the fork using tool Emb. 880.

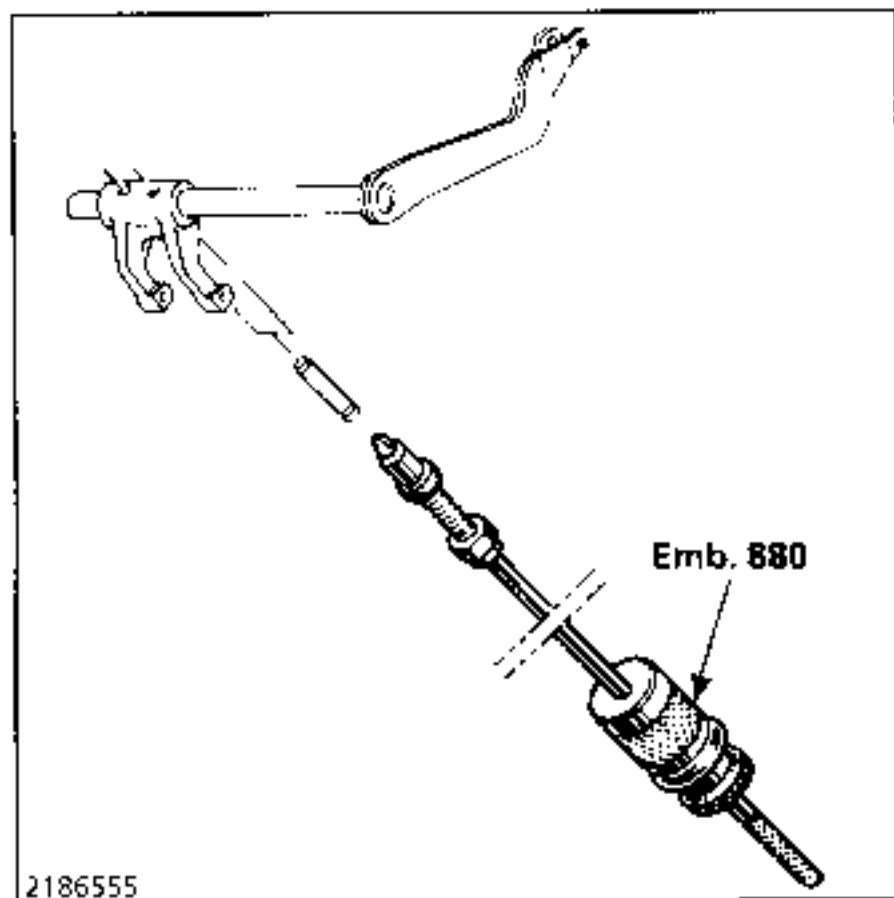

REFITTING - Special notes

Lubricate the fork shaft using **MOLYKOTE BR2**.

Fit the roll pins: ensure that distance **D** in relation to the fork is observed.

$$D = 1 \text{ mm}$$

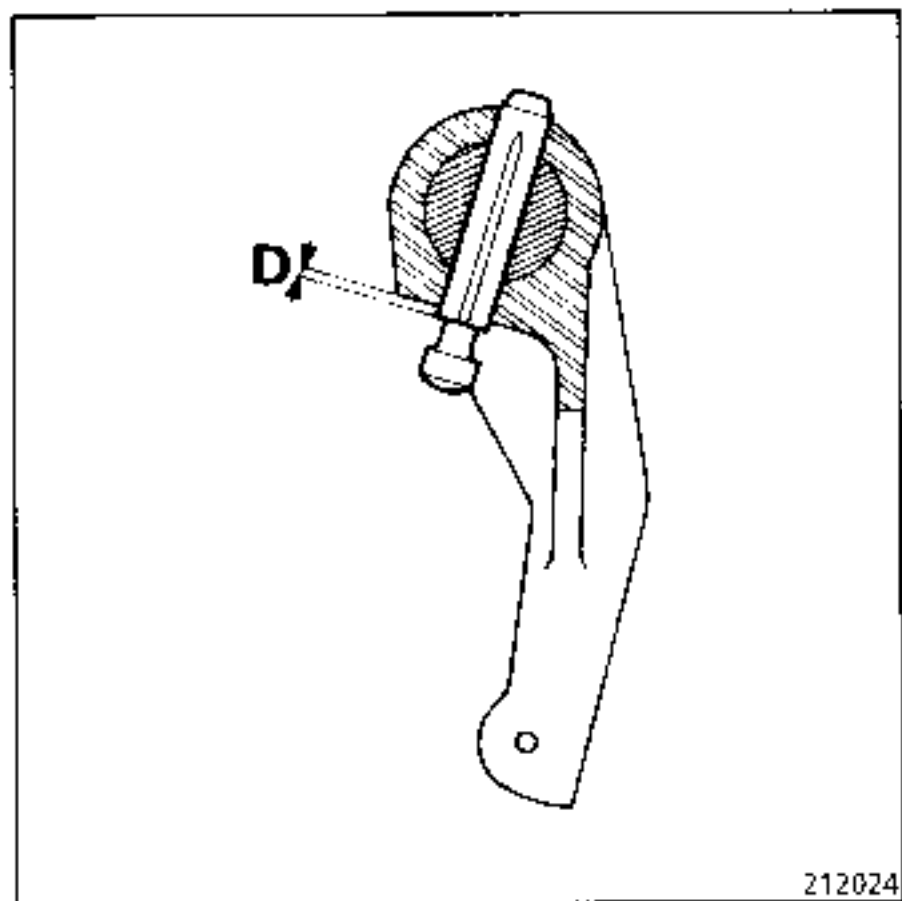

Lubricate the thrust pad guide and fork pads with **MOLYKOTE BR2**.

REPLACEMENT

SPECIAL TOOLING REQUIRED		
B.Vi.	606	Set of punches
Car.	41	Angled punch

This operation is carried out when the gearbox has been separated from the engine.

REMOVAL

Knock out the fork retaining roll pins half way using tool **B.Vi. 606** then remove them using tool **Car. 41**.

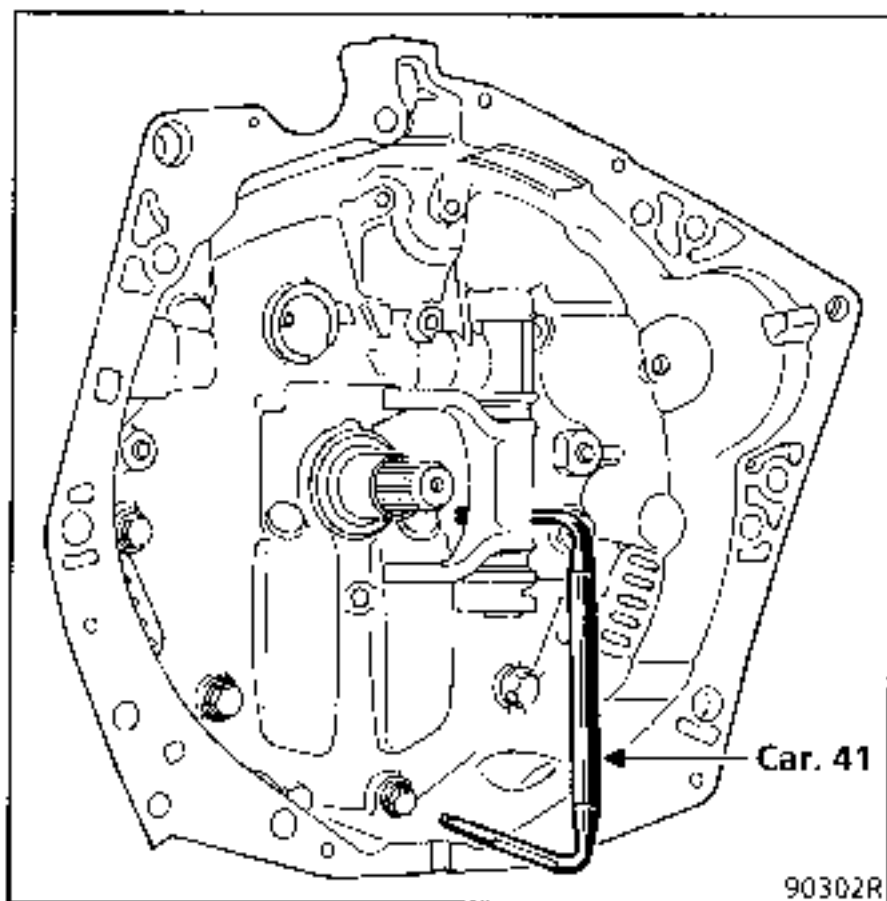

REFITTING

Lightly grease the fork shaft (**MOLYKOTE BR2**).

Engage the shaft (fitted with sealing rubber) and fit the fork and the two plastic spacers. Observe the fitting direction for the fork: boss at the clutch bellhousing end.

Align the holes in the fork with those on the shaft and fit the roll pins.

Make sure that the roll pins are fitted the correct way round. The slots in the roll pins should be perpendicular to the fork shaft and facing in opposite directions.

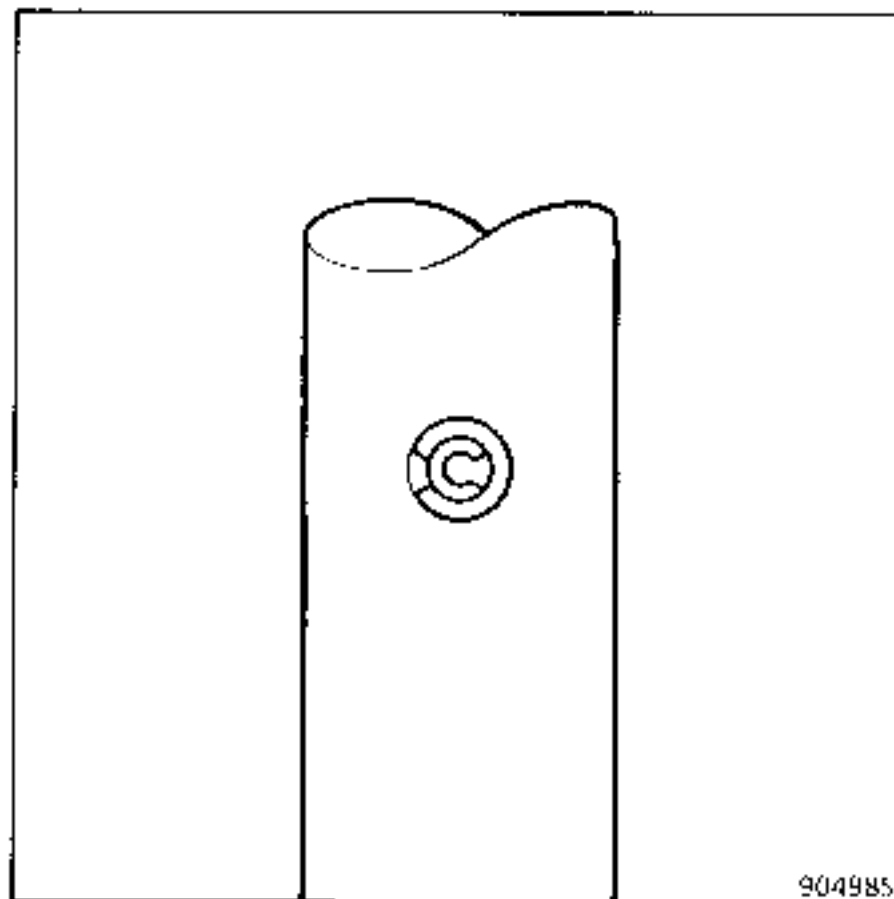

REPLACEMENT

This operation is carried out when the gearbox has been separated from the engine and the clutch removed.

SPECIAL TOOLING REQUIRED

Mot. 11 Hub extractor
Plus tooling for removing the gearbox

REMOVAL

Extract the bearing using tool Mot. 11.

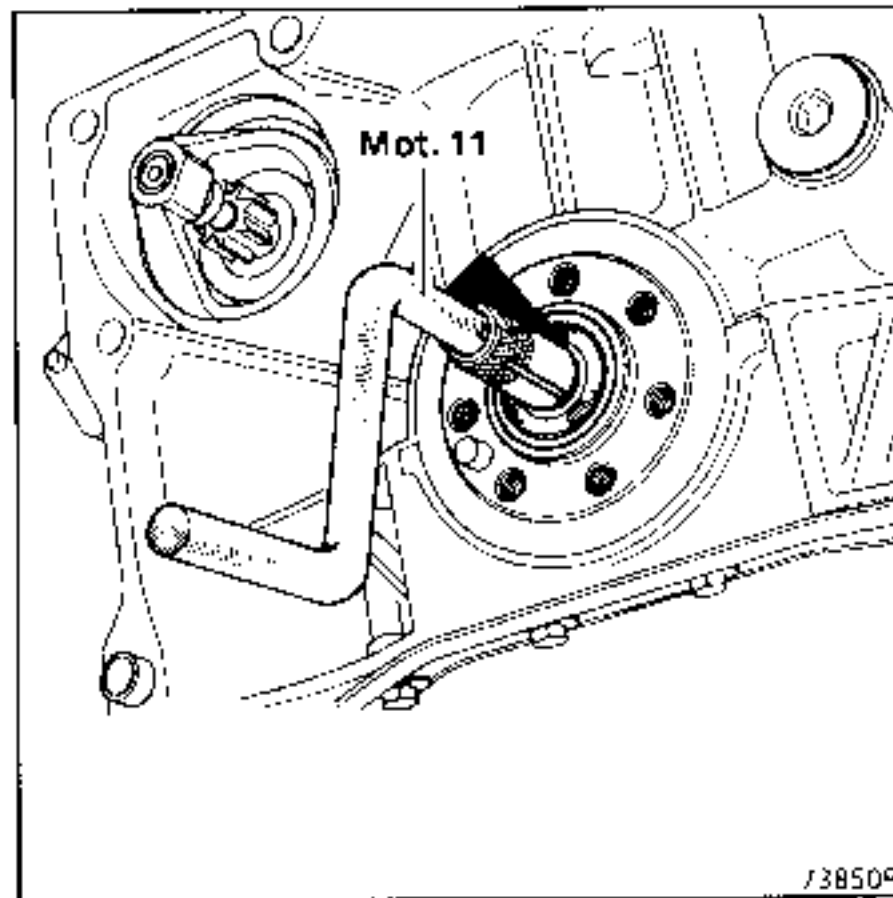
**REFITTING**

Fit the new bearing; this is supplied greased - only the outer diameter requires cleaning.

Coat the outer diameter of the bearing with **LOCTITE FRENBLOC**.

Fit the bearing using a tube, taking the weight on the outer cage.

JB2

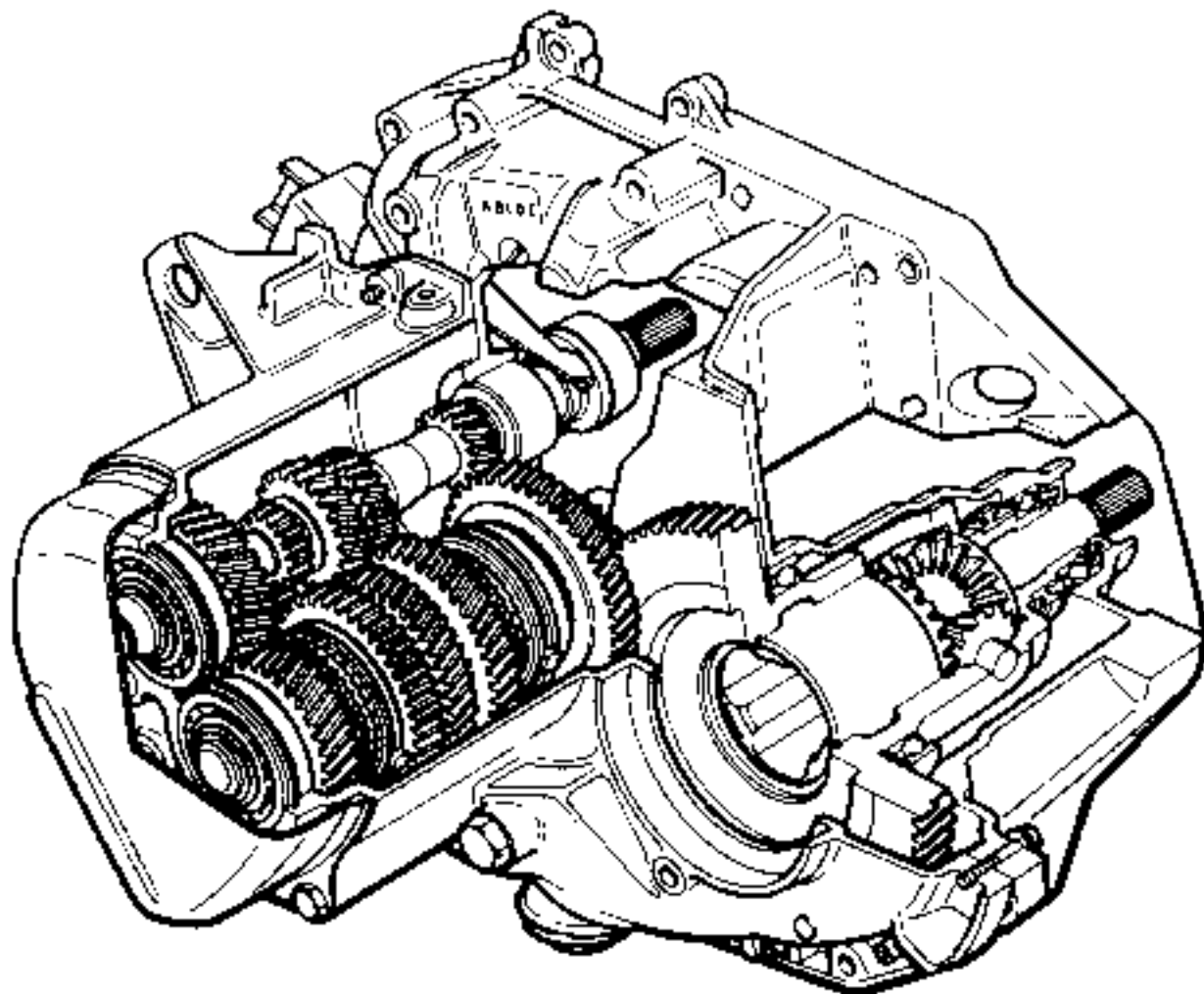

71211-1

JB1
JB3

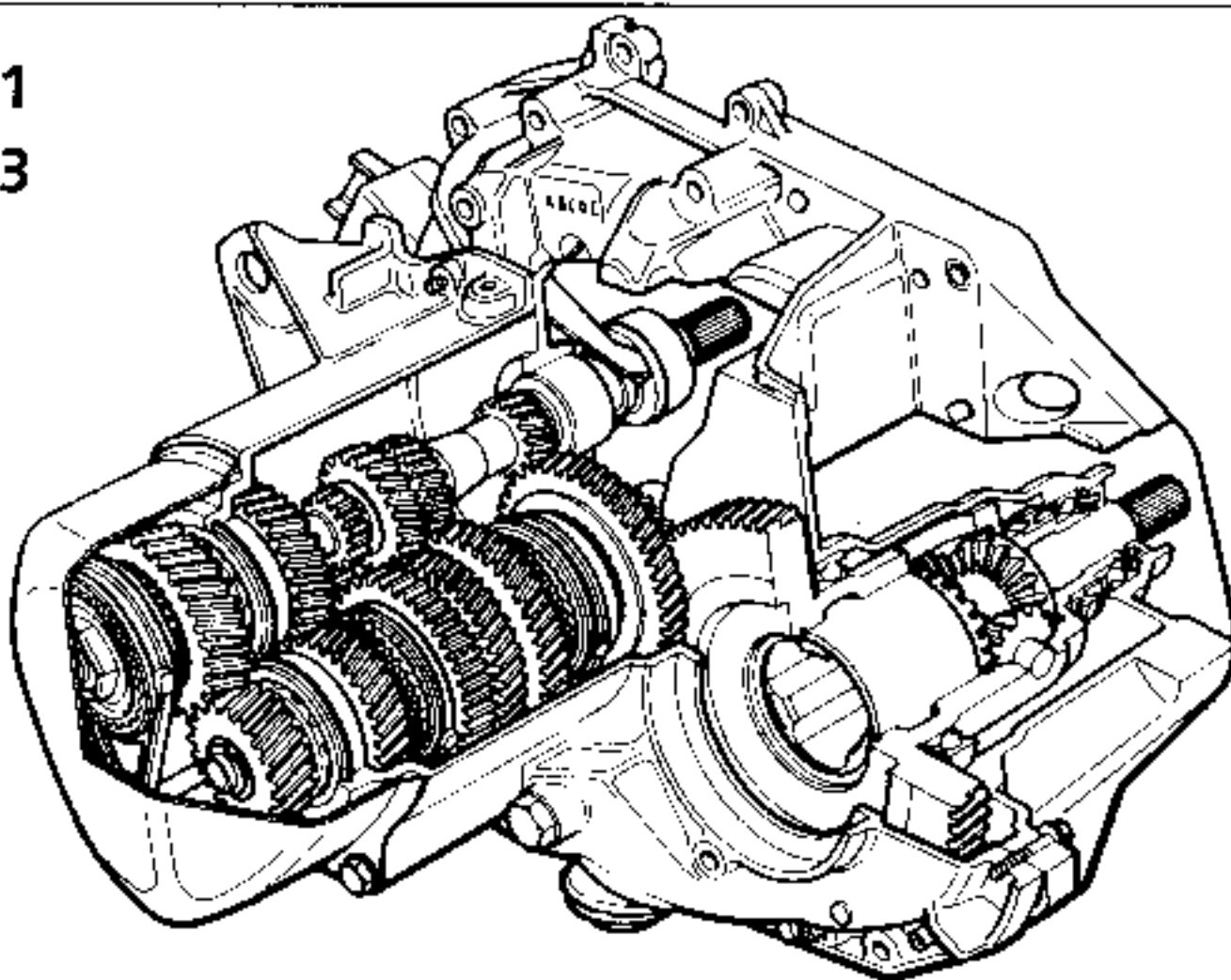

71211-2

NG9

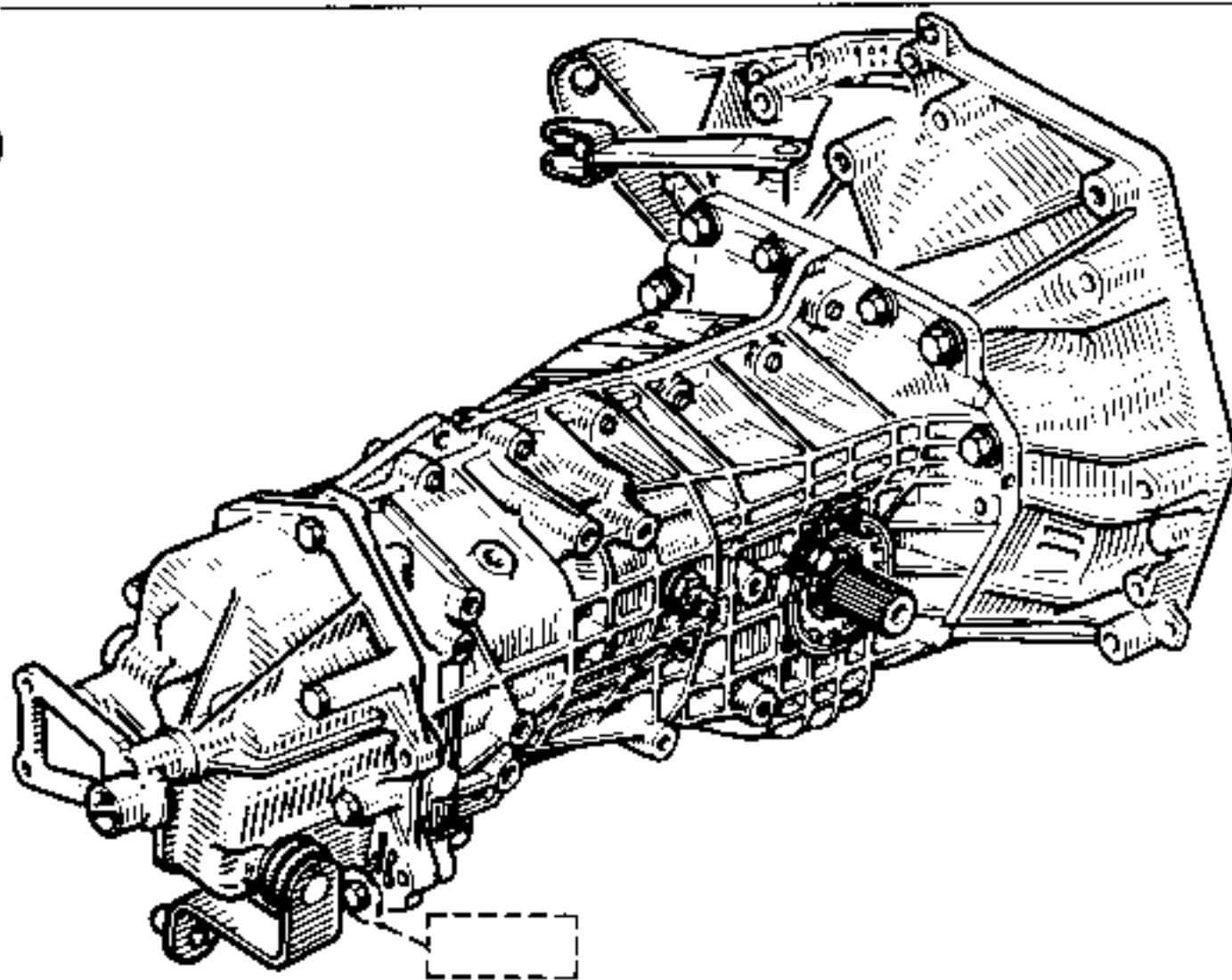

212'2'

NG7

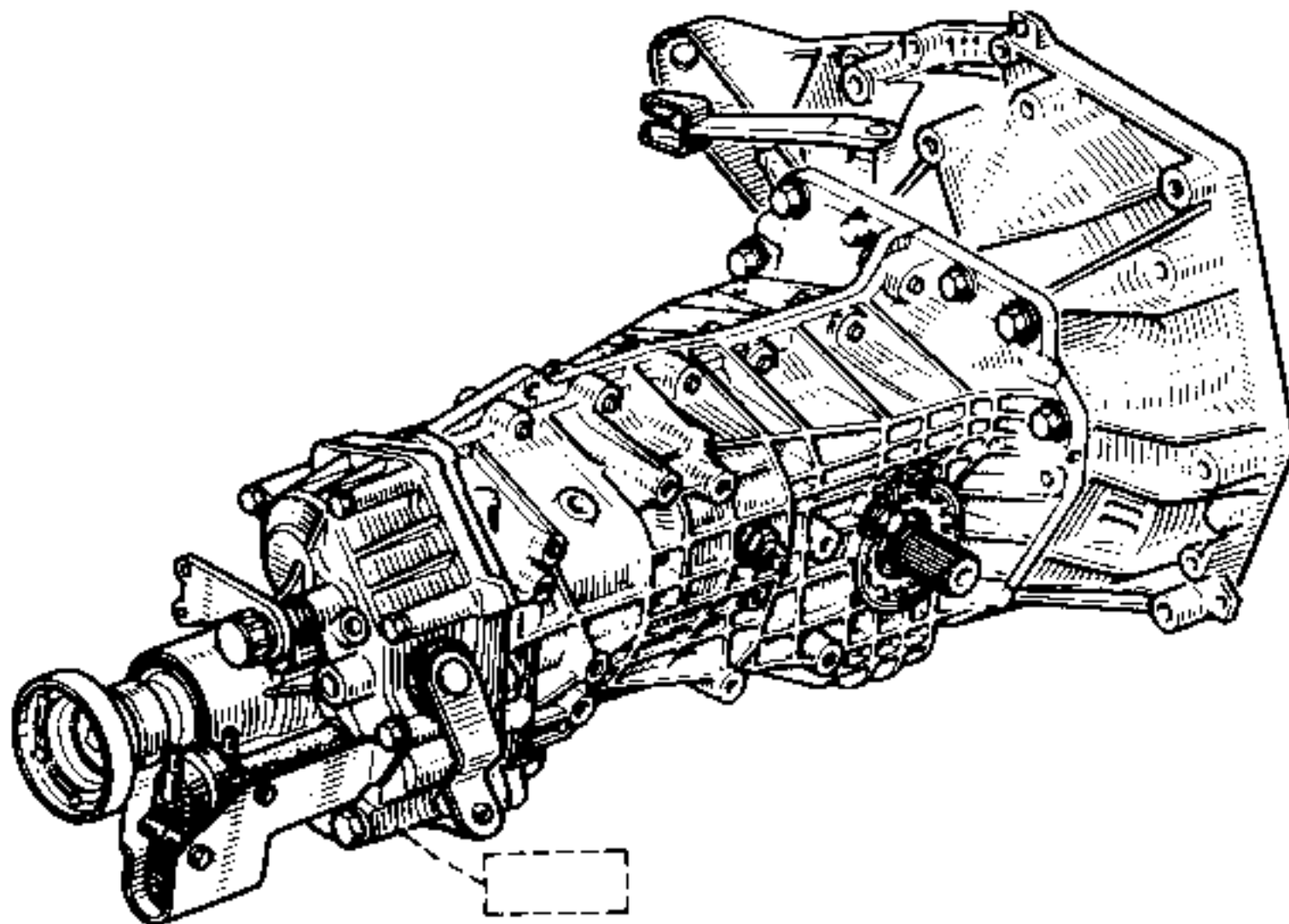

21212-2

UN1

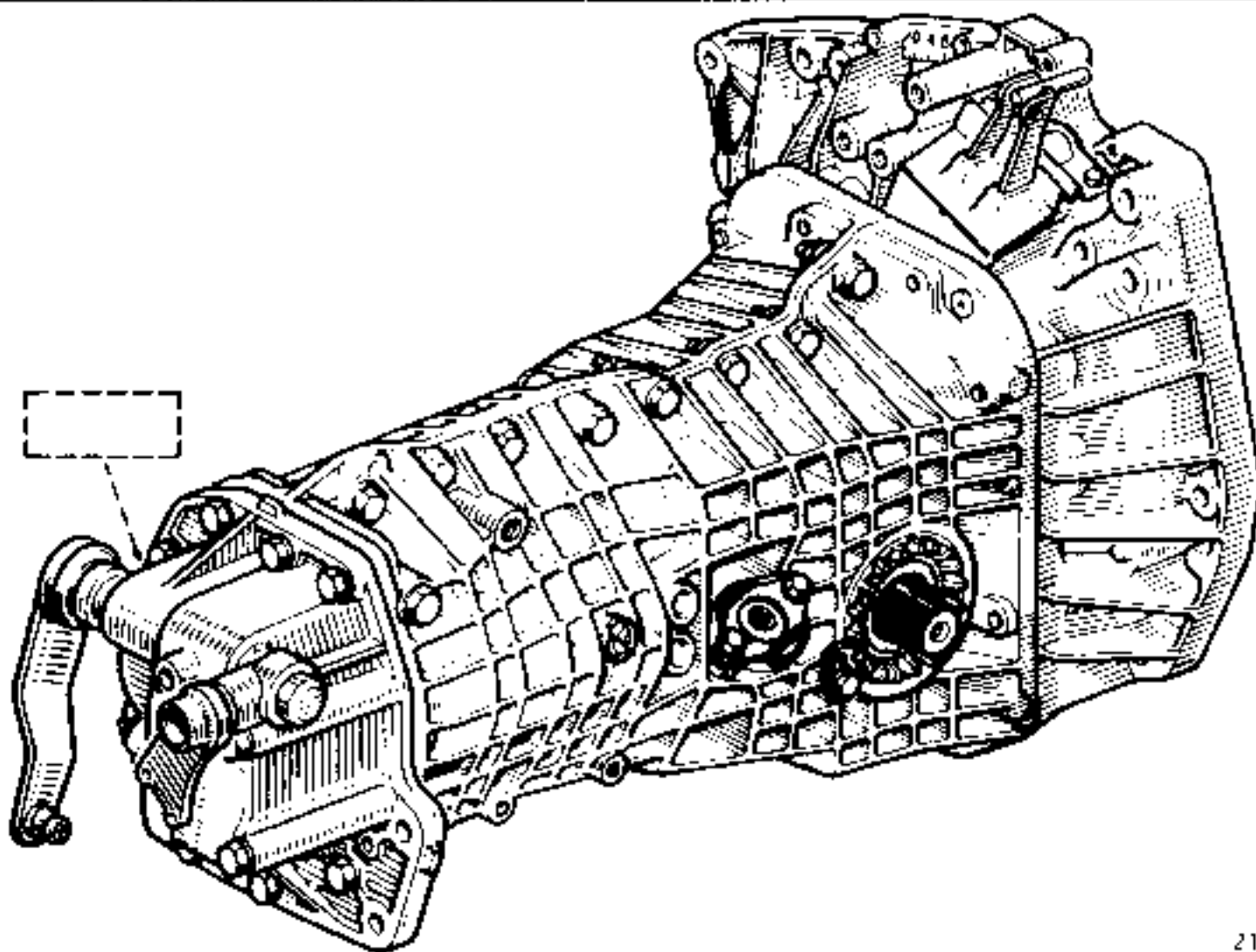

21213-1

UN7

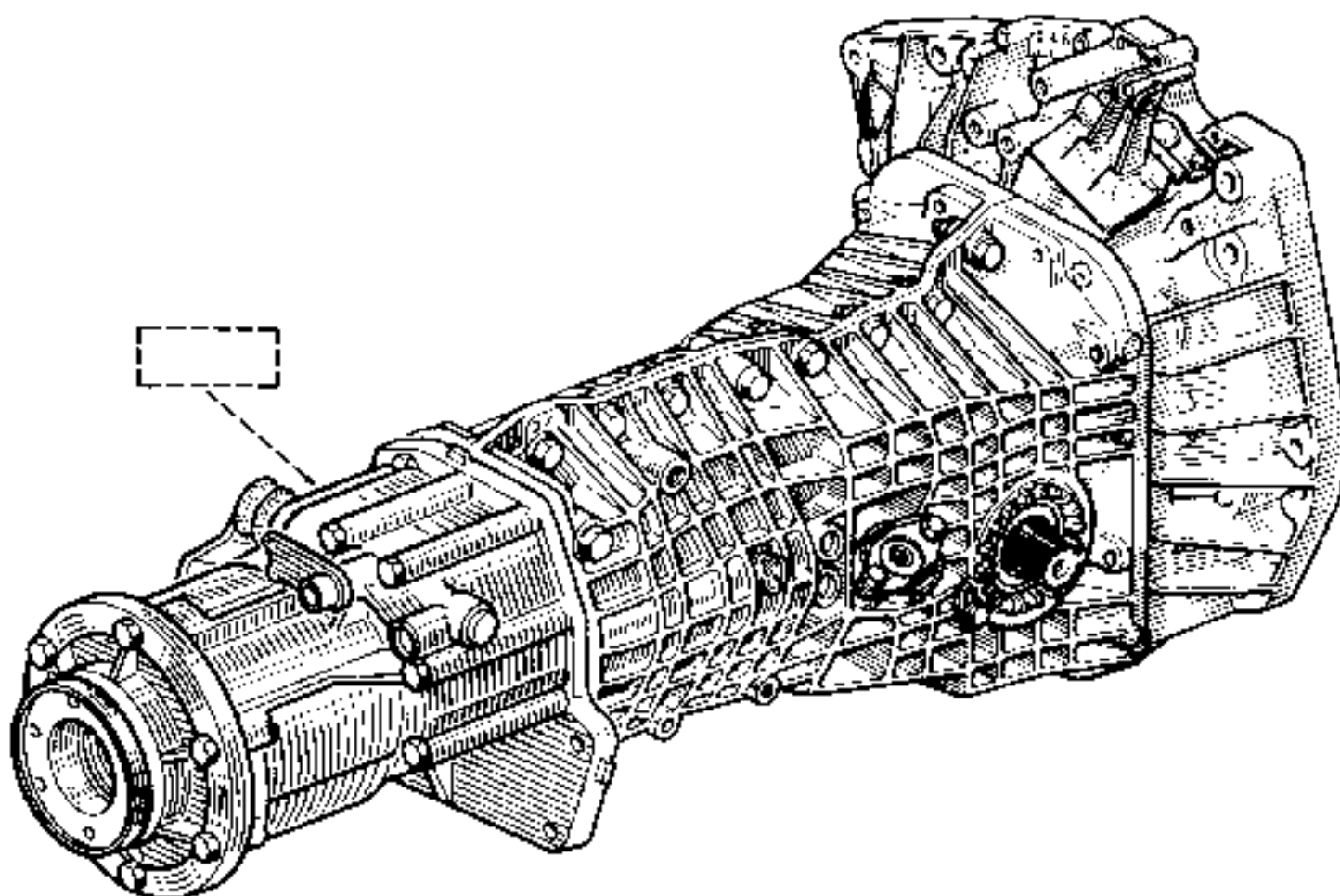

21213-2

X48 vehicles with "transverse engines" are fitted with the JB type gearbox.

Workshop Repair Manual "B.V. JB" deals with the complete overhaul of this component.

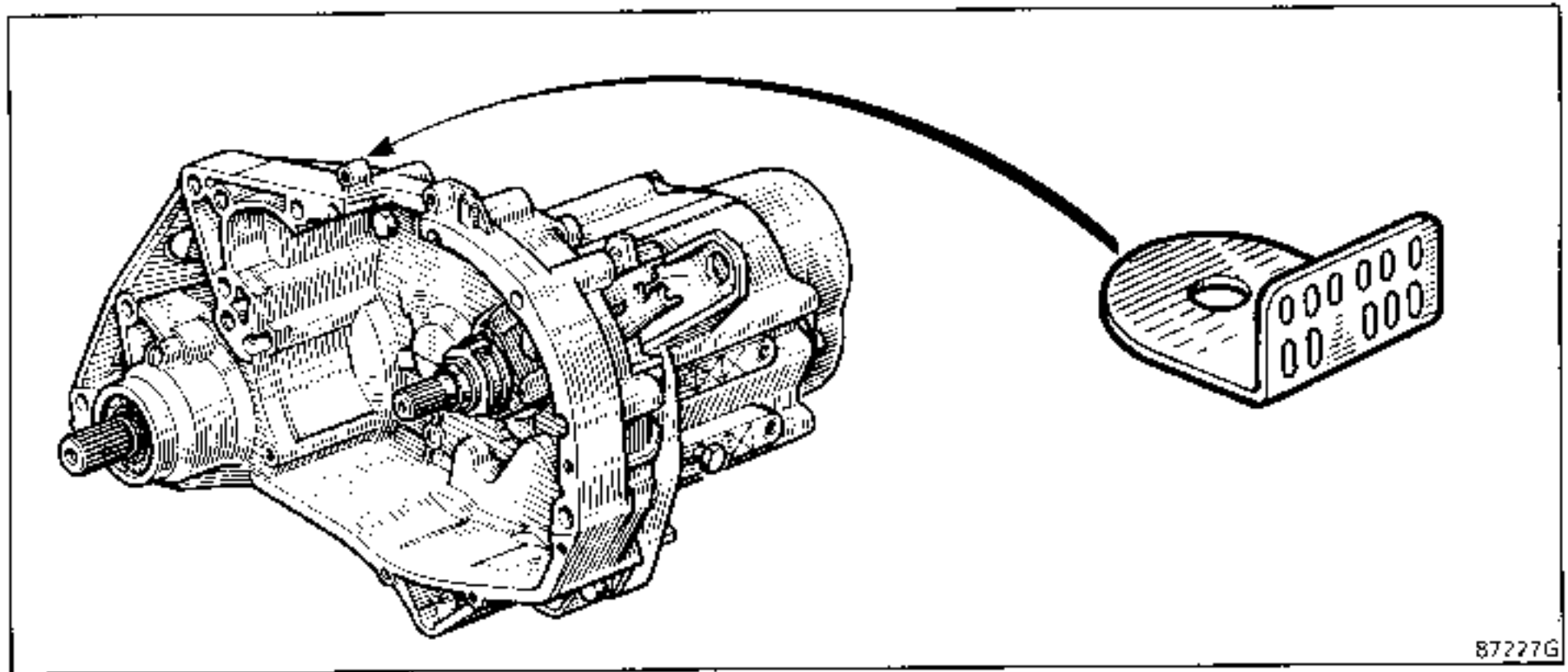

An identification plate on the clutch bellhousing shows:

- at **A** : the gearbox type,
- at **B** : the gearbox suffix,
- at **C** : the fabrication number,
- at **D** : the factory of manufacture,
- at **E** : a notch when the gearbox is assembled with a C or E type engine,
- at **F** : a letter preceding fabrication numbers greater than 999 999.

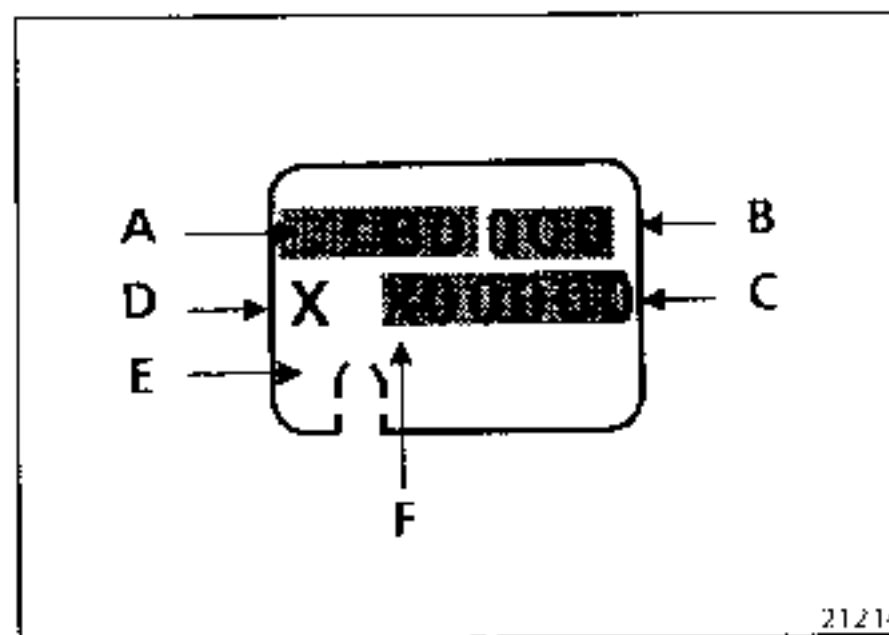

TWO COLOUR MARKING (JB1 - JB2 - JB3)

2/3 of the surface is painted with a colour specific to each gearbox, enabling them to be matched with the driveshafts.

The remaining 1/3 of the surface is painted with a colour specific to the gearbox suffix.

X48 vehicles with "in line" engines and X48 "4 x 4" vehicles are fitted with **NG** or **UN** type gearboxes.

Workshop Repair Manuals "BV - NG", "BV - UN and BV - UN7" deal with the complete overhaul of these components.

A plate mounted on the rear housing shows:

- at **A** : the gearbox type,
- at **B** : the gearbox suffix,
- at **C** : the fabrication number,
- at **D** : the factory of manufacture.

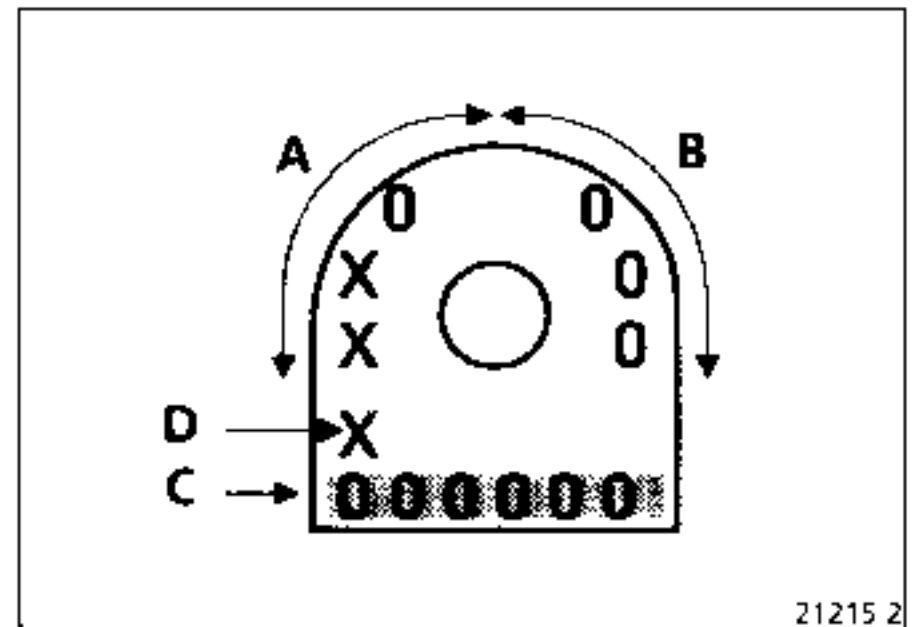
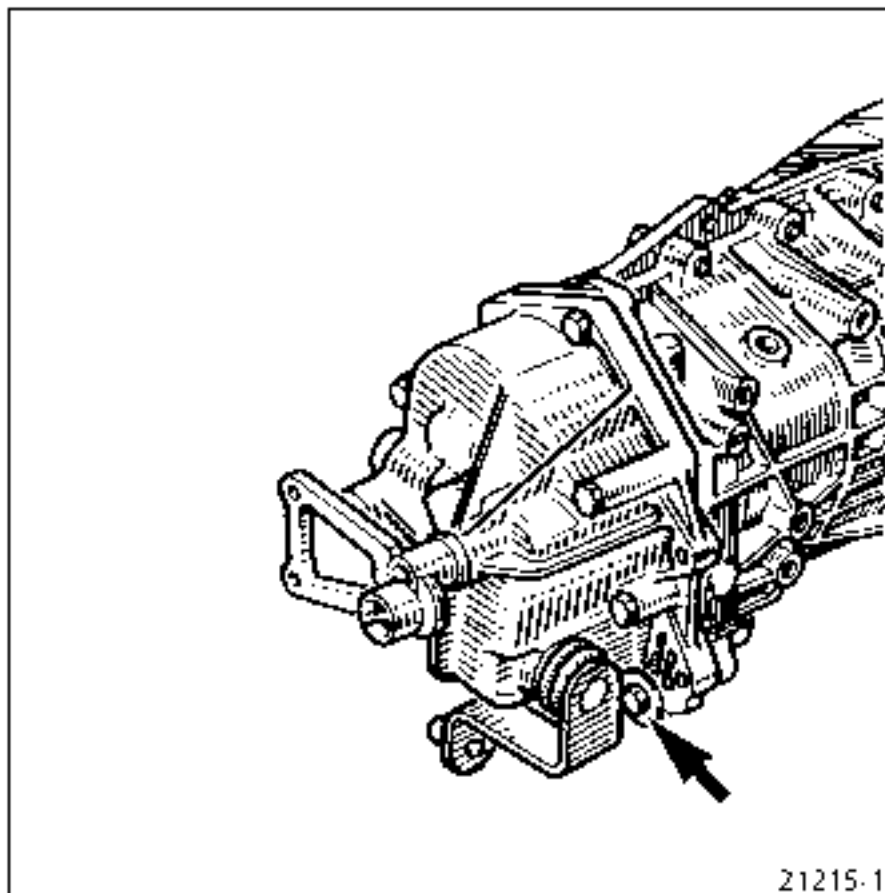

JB1									
Suffix	Vehicle	Final drive	Speedo drive	1st	2nd	3rd	4th	5th	Reverse
029	B-L-K 48D	15 — 61	21 — 19	11 — 41	21 — 43	28 — 37	30 — 29	39 — 31	21 — 26 39

JB2								
Suffix	Vehicle	Final drive	Speedo drive	1st	2nd	3rd	4th	Reverse
000	L-K-S 481 L-K 48 M	17 —	21 —	11 —	19 — 39	25 — 33	31 —	11 — 26 39
002 004	B-L-K-S 481 B-L-K 48M	56	19	41	21 — 43	28 — 37	28	

JB3										
Suffix	Vehicle	Final drive	Speedo drive	1st	2nd	3rd	4th	5th	Reverse	
010	L-K-S 482 L-K 48F L-K 48 M	16 — 57	21 — 19	11 — 41	19 — 39	25 — 33	30 — 29	34 — 27	11 — 26 39	
017	L 482 L-K 48J L-K 48N L-K 48E	15 — 61		11 — 34	19 — 35			33 — 25		
022	L-K 482 Spain	15 — 58		11 — 41	19 — 39			34 — 27		
027 059	B-L-K 481 B-L-K 482 B-L-K 48E B-L-K 48J B-L-K 48N	15 — 61		11 — 34	22 — 41			41 — 31		28 — 37
028 060	B-L-K-S 481 B-L-K 482 B-L-K 48F B-L-K 48H B-L-K 48M	16 — 57		11 — 41	21 — 43			39 — 31		

JB3										
Suffix	Vehicle		Final drive	Speedo drive	1st	2nd	3rd	4th	5th	Reverse
031	B-L-K	482	15							
061	B L K	484	— 58	21	11	21	28	30	39	11
				—	—	—	—	—	—	— 26
038	B-L K	48V	15	19	41	43	37	29	31	39
063	B	484	—							
	L	482	61							

NG9																																										
Suffix	Vehicle		Final drive	Speedo drive	1st	2nd	3rd	4th	5th	Reverse																																
000	B-L-K	48C	9 — 31	6	11 — 45	17 — 37	22 — 31	33	36	11 — 23 39																																
	B-L-K	483		—				34	31																																	
	B-L-K	489		—				—	—																																	
	B-L-K	48K		18				34	31																																	
	B-L-K	48B		—				—	—																																	
001	B-L-K	487	9	6				11 — 45	17 — 37		22 — 31	34	37	11 — 23 39																												
	B-L-K	488	—	—								33	29																													
	B-L-K	48W	31	18								33	31																													
	B-L-K	48P	—	—								—	—																													
002	B-L-K-S	486	9	8								11 — 45	17 — 37		22 — 31	33	36	11 — 23 39																								
	B-L-K-S	48V	—	—	34	31																																				
	B-L-K-S	480	29	23	34	31																																				
003	L-K	48A	10	8	11 — 45	17 — 37	22 — 31			34						37	11 — 23 39																									
			—	—						33						29																										
005	L-K	483	9	6						11 — 45						17 — 37			22 — 31	33	36	11 — 23 39																				
			—	—				34	19																																	
006	L-K	486	9	6							11 — 45			17 — 37									22 — 31	33	36	11 — 23 39																
			—	—																							31	18														
007	L	489	9	6																									11 — 45	17 — 37	22 — 31	34	31	11 — 23 39								
			—	—								32	19																													
008	L-K	485	9	6											11 — 45			17 — 37																	22 — 31	34	31	11 — 23 39				
			—	—																																			31	18		
009	B-L	48Y	9	6	11 — 45	17 — 37	22 — 31										28																								37	11 — 23 39
			—	—													43																								43	
			31	18						43						40																										

NG7										
Suffix	Vehicle		Final drive	Speedo drive	1st	2nd	3rd	4th	5th	Reverse
003	K	483	9 — 31	6	11 — 45	17 — 37	22 — 31	33	36	11 — 23 39
	K	48K		—				—		
	K	48B		18				34	31	
004	K	486	31	18	11 — 45	17 — 37	22 — 31	34	31	11 — 23 39
	K	48V								

UN1										
Suffix	Vehicle		Final drive	Speedo drive	1st	2nd	3rd	4th	5th	Reverse
013	L	485	9	23	11	17	21	27	39	11
	L	48L	—	—	—	—	—	—	—	— 25
			31	20	37	35	29	28	32	39

UN7 (4 x 4)										
Suffix	Vehicle		Final drive	Speedo drive	1st	2nd	3rd	4th	5th	Reverse
000	L	485	9							
	L	48L	—							
001	L-B	48Y	9	23	11	17	21	27	39	11
	L-B	48Q	—	—	—	—	—	—	—	— 25
	L-B	48R	37	20	37	35	29	28	32	39
002	B-L	483	9							
	B-L	48K	—							
			35							

CAPACITY (in litres)

JB2	3.25	TRX 75W 80W
JB1 JB3	3.4	TRX 75W 80W
NG9	2.2	TRX 80W
NG7	2.4	TRX 80W
UN1	3	TRX 80W
UN7	3.35	TRX 80W
OT2	1.3	TRX 80W

CHECKING THE LEVEL

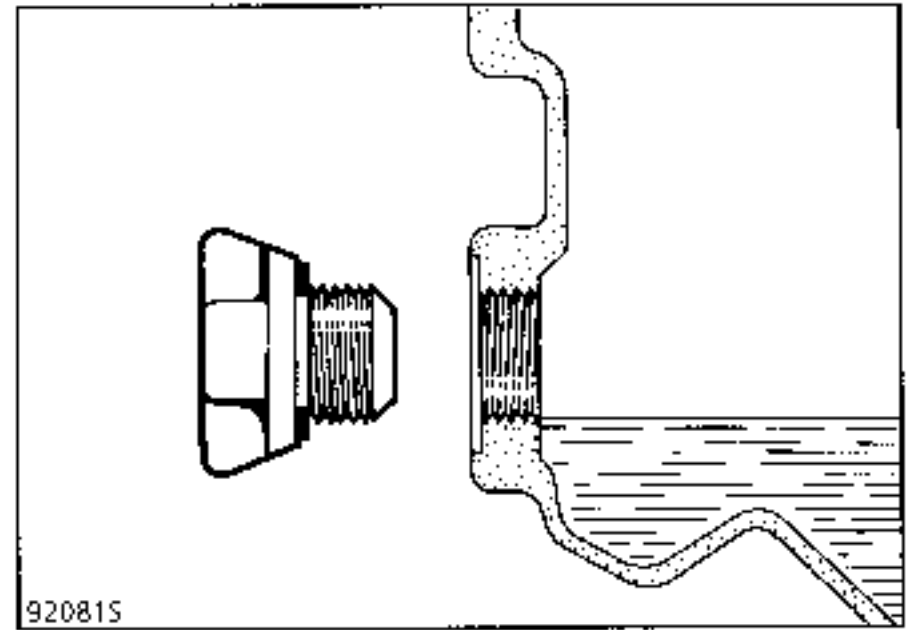

Fill to the level of the aperture.

SPECIAL PRECAUTIONS

TRANSELF TRX oil is a high technology product requiring certain precautions to be taken in order to prevent foreign bodies entering it, which could damage the quality of the oil and make gear changing difficult. The following recommendations should therefore be observed:

Storage of oil cans

Cans must be stored:

- away from inclement weather (rain, snow, splashes),
- in a dry place (avoid locations near to washing equipment),
- hermetically sealed.

Storage of components (gearbox or final drive)

When storing a gearbox or final drive which has not been drained, plug any air inlets.

Store components in a dry location.

Using the oil

Oil cans must be closed after each use. Never decant oil into a larger container as this brings a greater surface into contact with the outside air.

Pressure washing (of the vehicle or a component)

Plug the gearbox and final drive breathers.

If the gearbox or final drive is removed, plug the openings correctly to prevent water from entering.

The following gearboxes:

JB2 4 forward gears
1 reverse gear

JB1 5 forward gears

JB3 1 reverse gear

are fitted with **BORG-WARNER** synchronisers.

NG and **UN** gearboxes with:

5 forward gears
1 reverse gear

are fitted with :

- **RENAULT** synchronisers for 1st and 2nd,
- **BORG-WARNER** synchronisers for 3rd, 4th and 5th.
- **NG7** : prop shaft differential lock control.
- **UN7** : New 1st/2nd synchro, which is smaller and has shorter travel.
- The intermediate housing contains the 5th gear, central differential and visco coupling.

GEAR SELECTOR

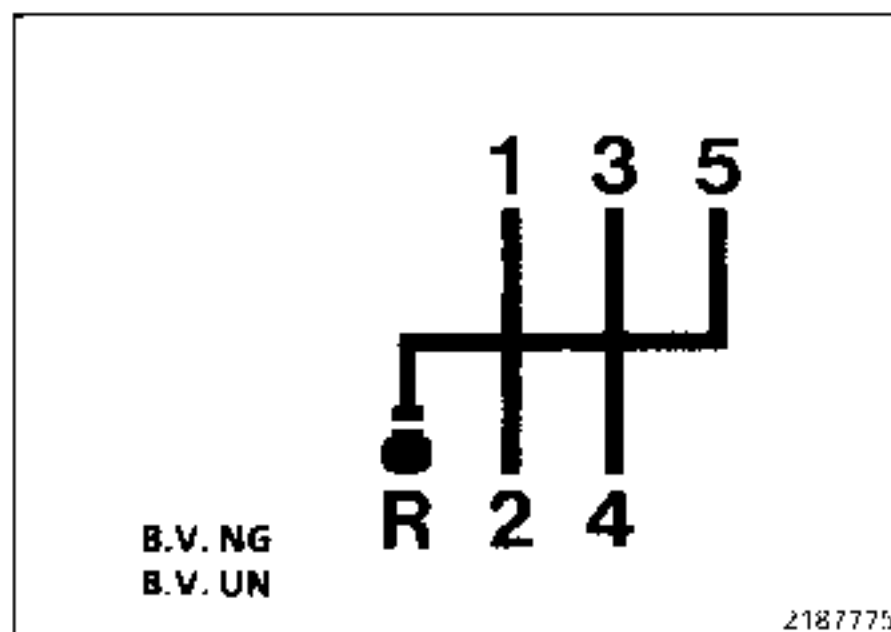
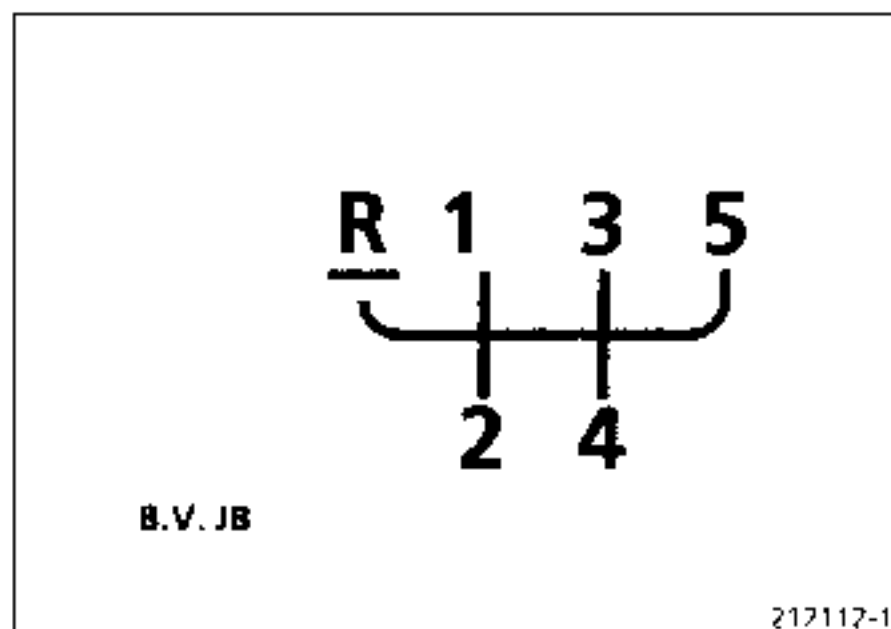

To select reverse, lift the locking ring (A) and move the lever.

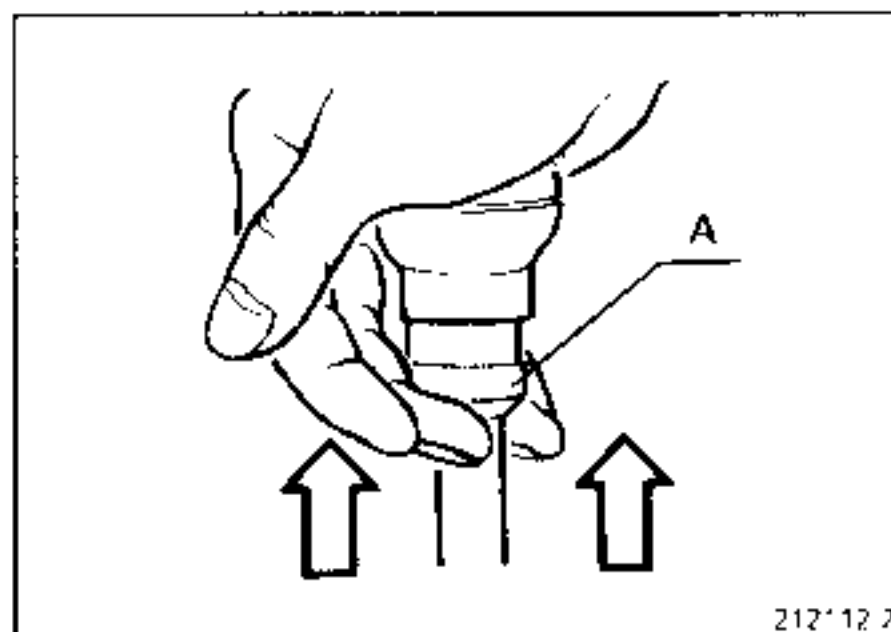

2ND GEAR SYNCHRO ASSISTANCE DEVICE

This device enables 2nd gear to be selected more easily.

Operation

When selecting 2nd gear, some of the force applied to the fork in order to move the sliding gear is absorbed by spring (R) located in the shaft (NG gearbox) or on the shaft (UN1 gearbox) in order to enable the selector lever to move immediately and to retard the complete movement of the fork.

NG gearbox

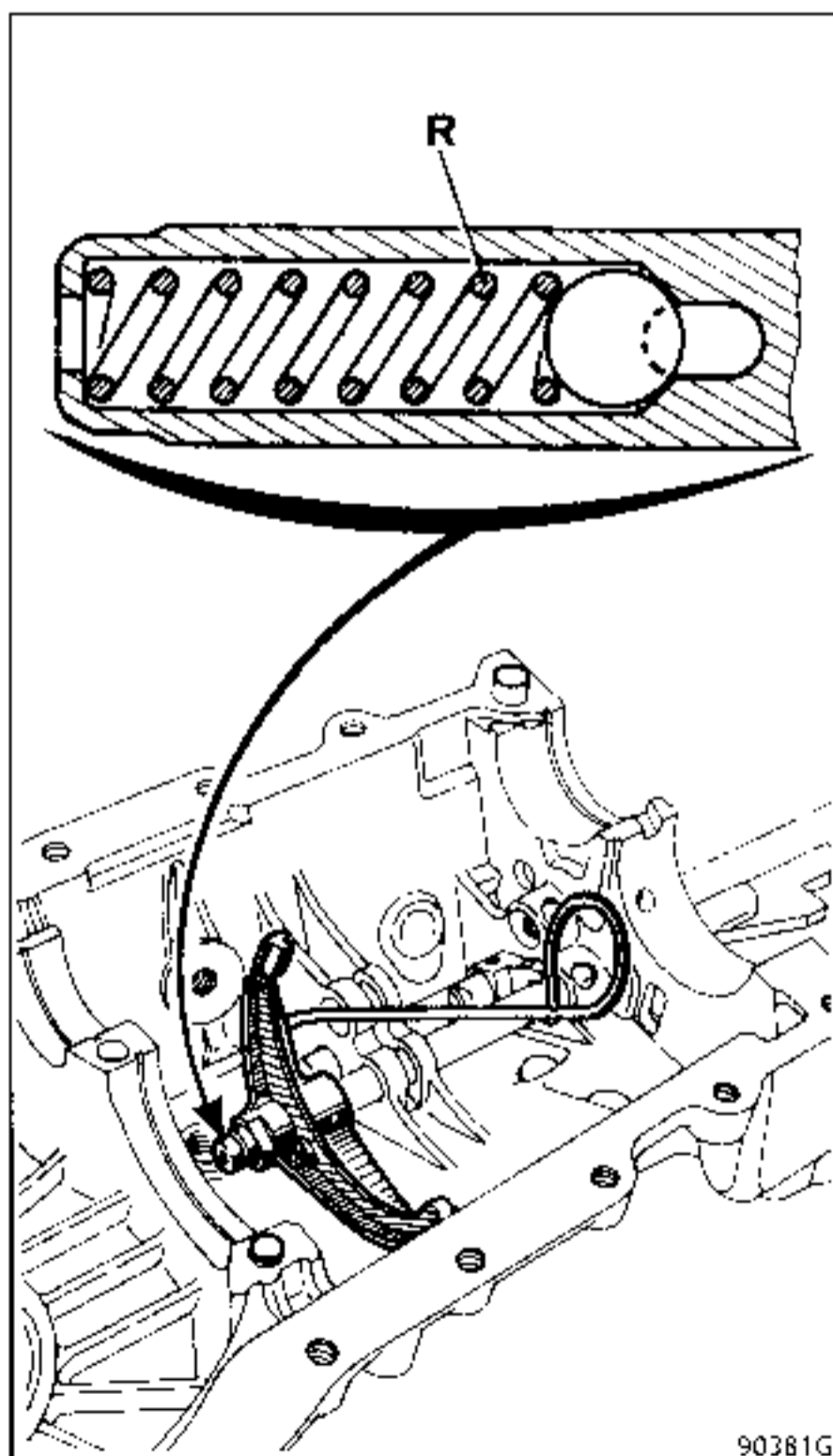

After fitting the roll pin, ensure that the fork slides on its shaft.

NOTE : with this modification, a 1/2nd locking plunger is fitted instead of a ball.

UN1 gearbox

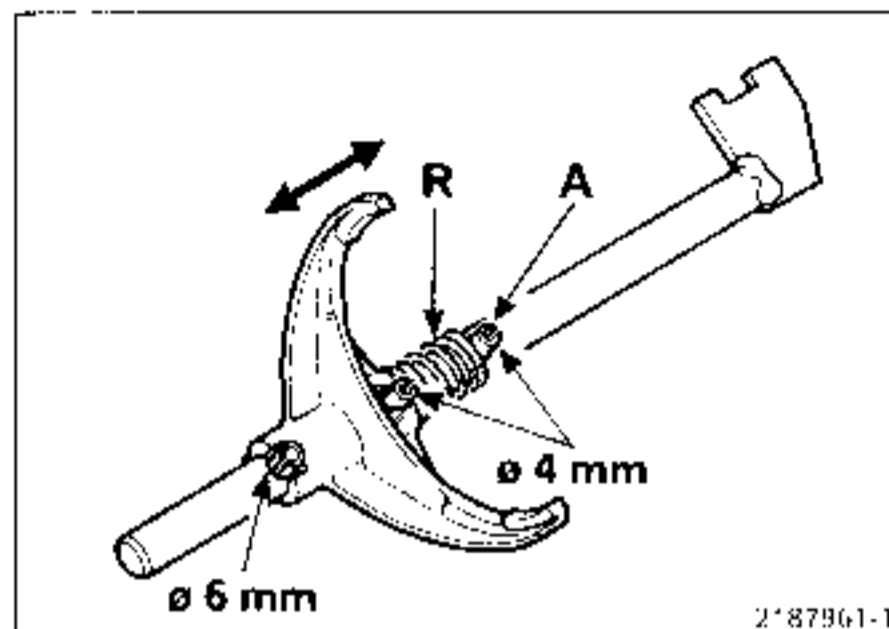

PRECAUTIONS

When fitting the 1st/2nd fork shaft, the roll pin (A) must be fitted correctly to avoid contact with the 1st gear : it should not project beyond the spring coils at the top.

REVERSE GEAR POSITIVE LOCKING

This system prevents reverse being engaged by mistake when the gears are changed quickly from 3rd to 2nd.

Operation

To select reverse gear, lift the locking ring (A) and move the lever; by means of a cable, the locking ring acts on the finger of a latch (V) mounted on the rear housing of the gearbox.

If this finger moves away, reverse gear is able to be selected.

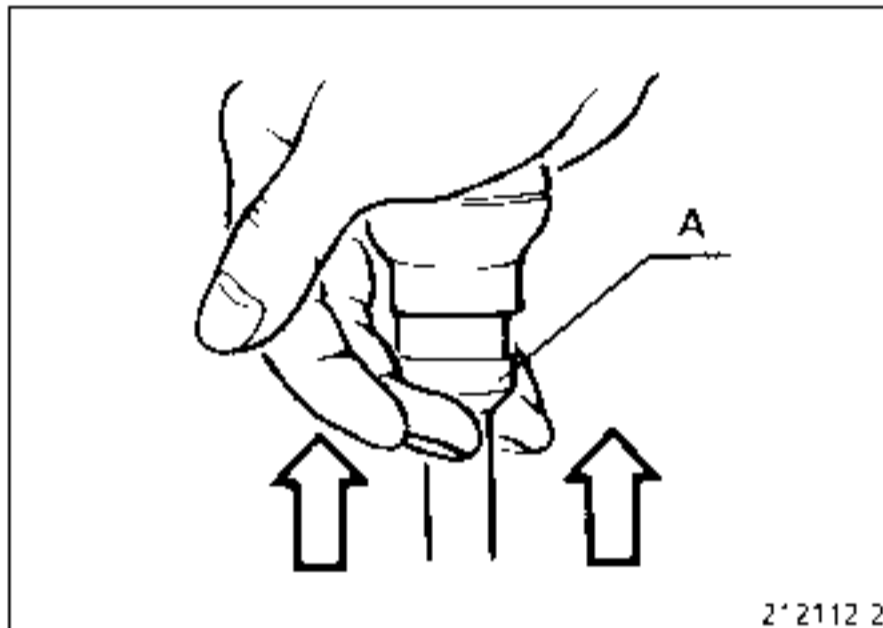

2' 2112 2

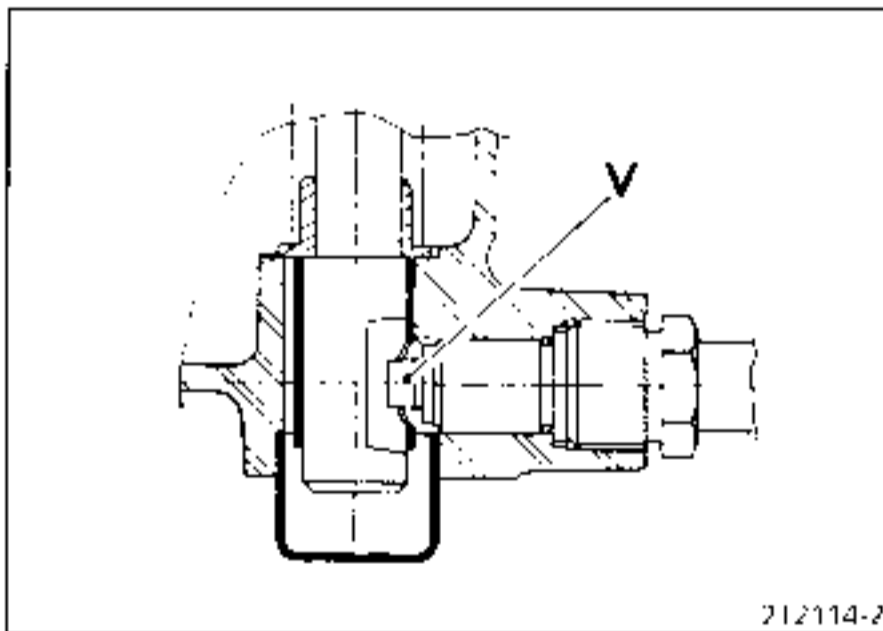

212114-2

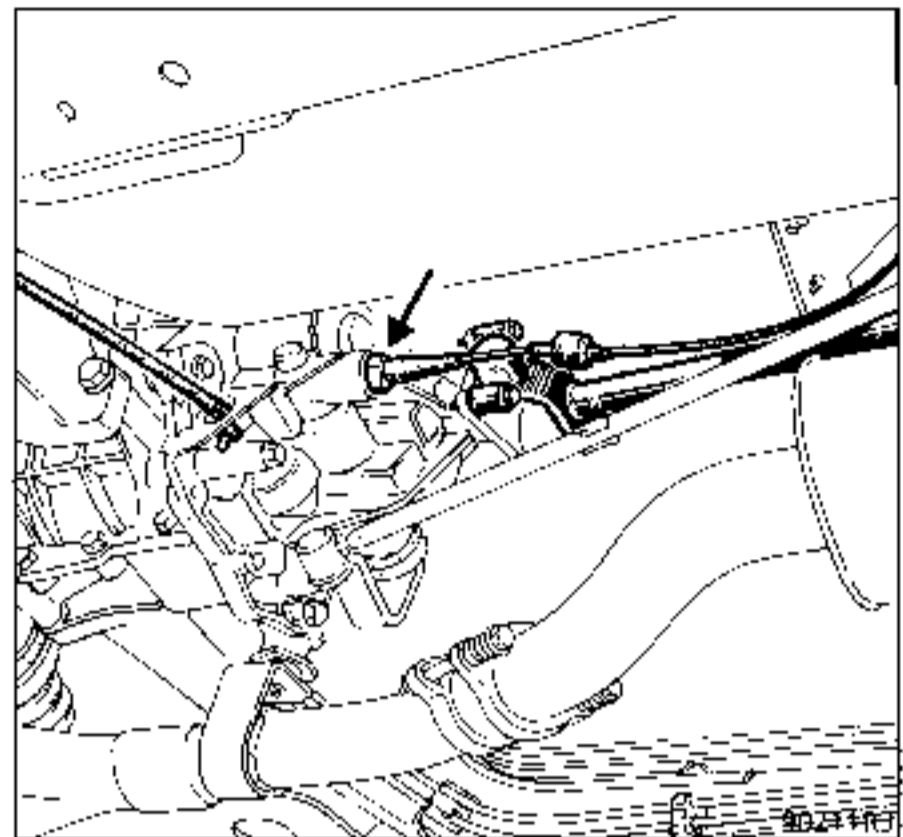

MATCHED PARTS

- Final drive pinion and crown wheel.
- Synchro hubs and sliding gears.
- Differential cups and bearing cones.

FINAL DRIVE MATCHING (NG and UN gearboxes)

The final drive pinion and crown wheel are ground together during production.

They are therefore inseparable.

If one of the parts has to be replaced, the other must also be replaced.

There is a common marking on the crown wheel and pinion.

The backlash cannot be adjusted.

HUB / SLIDING GEAR MATCHING

In all cases it is advisable to mark the sliding gears in relation to the hubs.

NG7

The speedo crown wheel is moulded onto the hub (output shaft), therefore if this crown wheel is damaged, the gearbox output shaft will have to be replaced.

The gearbox output shaft lip seal can only be removed after the rear housing has been removed and the shaft and bearing control shafts have been dismantled.

NG9 009 : Special notes

New "Small Module" teeth for 3rd, 4th and 5th.

The primary shaft has been modified and has a dual tapered bearing (2) instead of a bearing (1) with two rows of balls on the rear bearing journal.

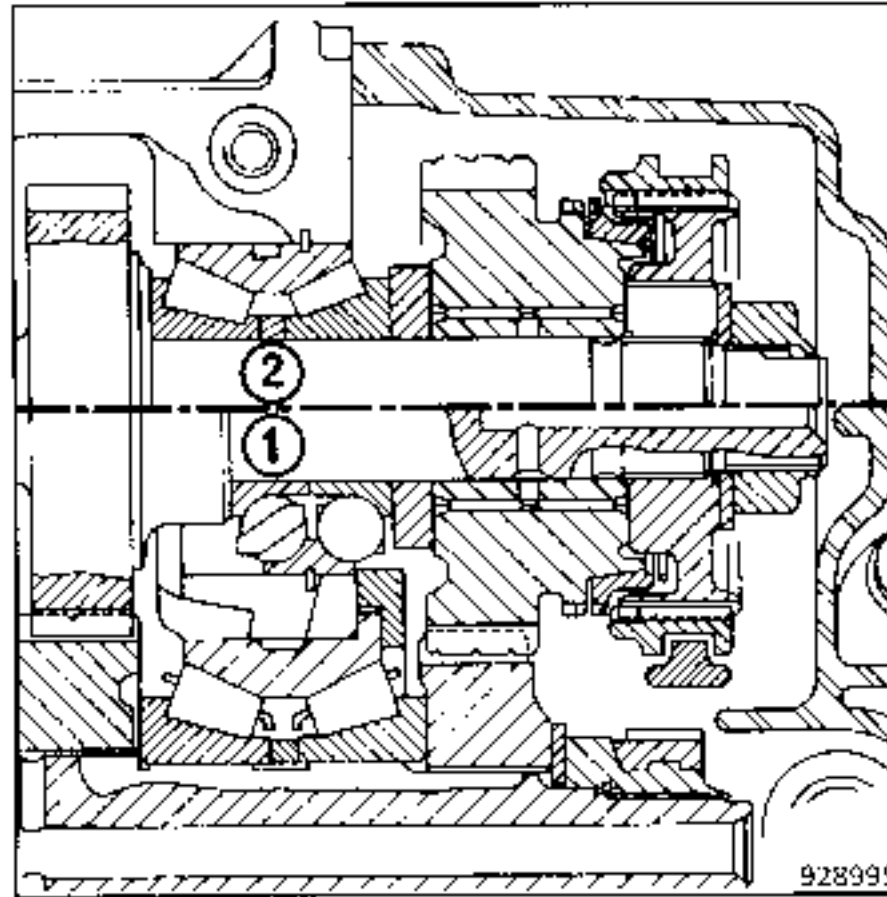

SPECIAL TOOLING REQUIRED

B.Vi.	31-01	Set of punches
T.Av.	476	Ball joint extractor

TIGHTENING TORQUES (in daN.m)



Brake caliper mounting bolt	10
Shock absorber base mounting bolt	11
Track rod end nut	3.5
Key nut on stub axle carrier	5.5
Mounting securing bolt	4 to 5
Wheel bolts	9
Left hand driveshaft gaiter mounting bolt	2.5

REMOVAL

The gearbox is removed alone (except for the **die-sel F8Q engine** fitted with increased inertia fly-wheel).

Put the vehicle on a lift or axle stands.

Drain the gearbox.

Disconnect the battery.

Remove the front wheels.

On the left hand side of the vehicle, remove:

- the track rod end using tool T.Av. 476,

- the three driveshaft gaiter mounting bolts,
- the two caliper mounting bolts, securing the caliper to the suspension spring to prevent the cable from stretching,
- the side protection housing (1 bolt and 3 rivets),

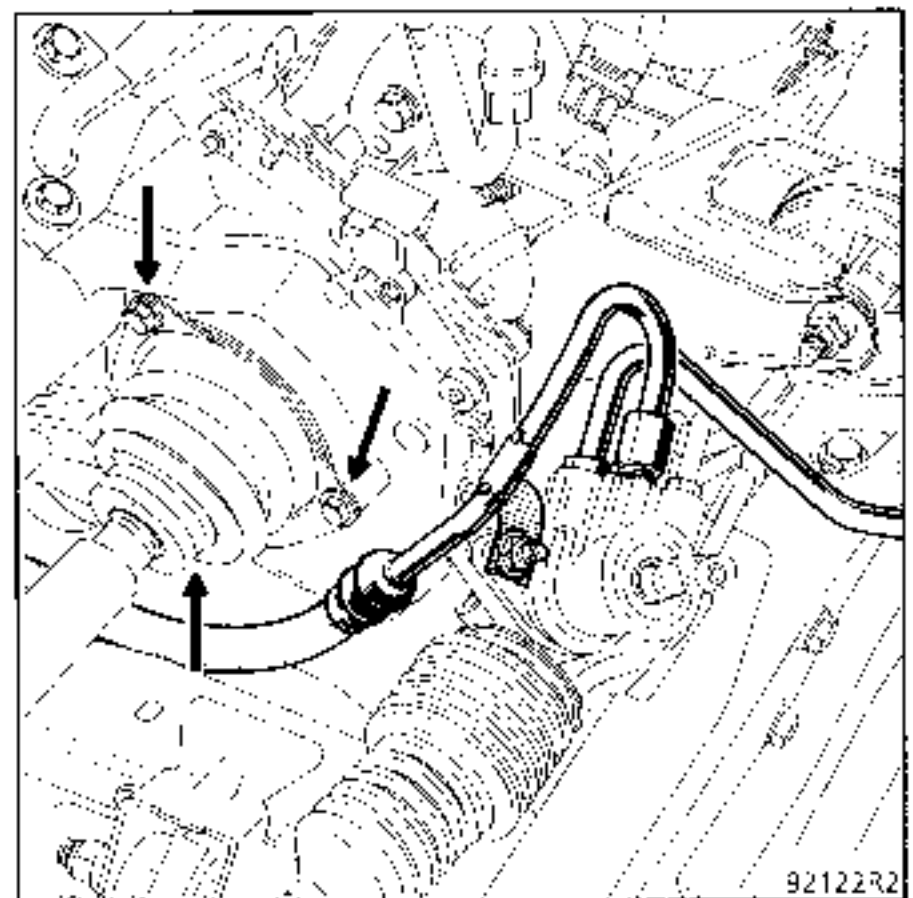
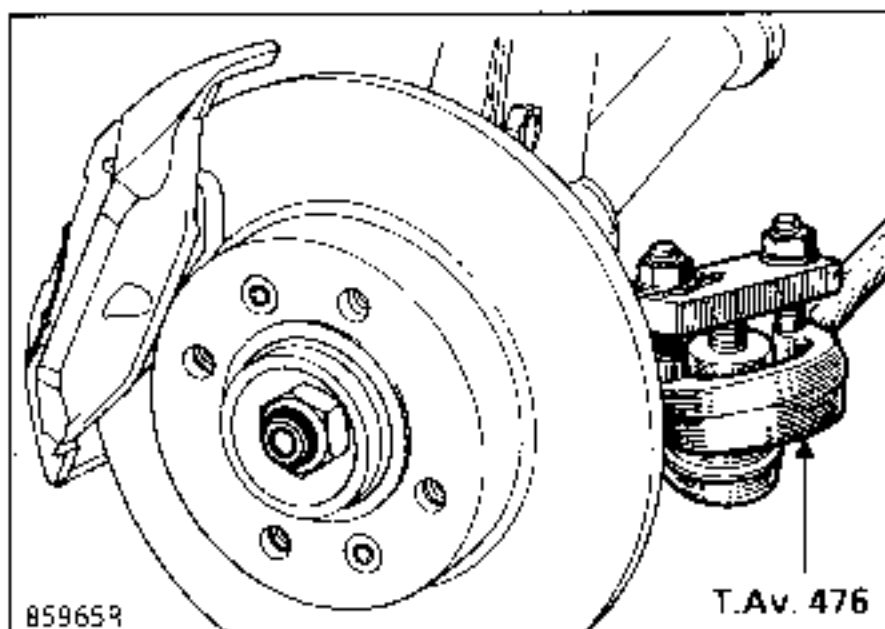

the two bolts (1) at the base of the shock absorber,

the nut and the key (2),

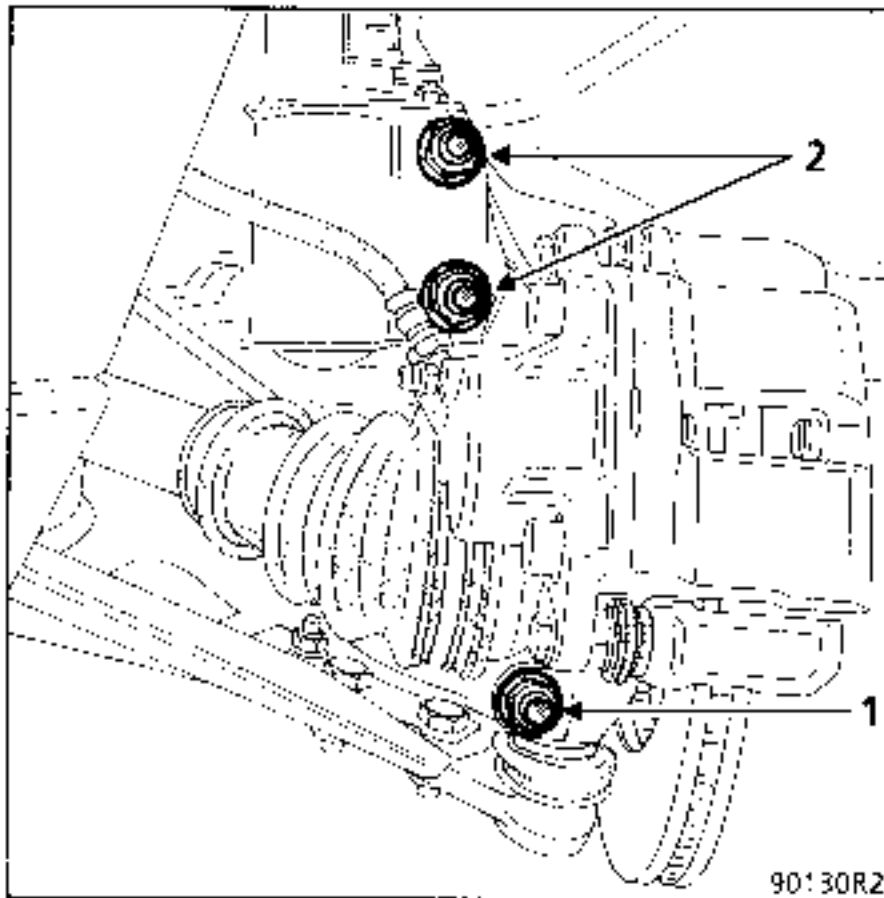

- the stub axle carrier - driveshaft assembly at the lower ball joint.

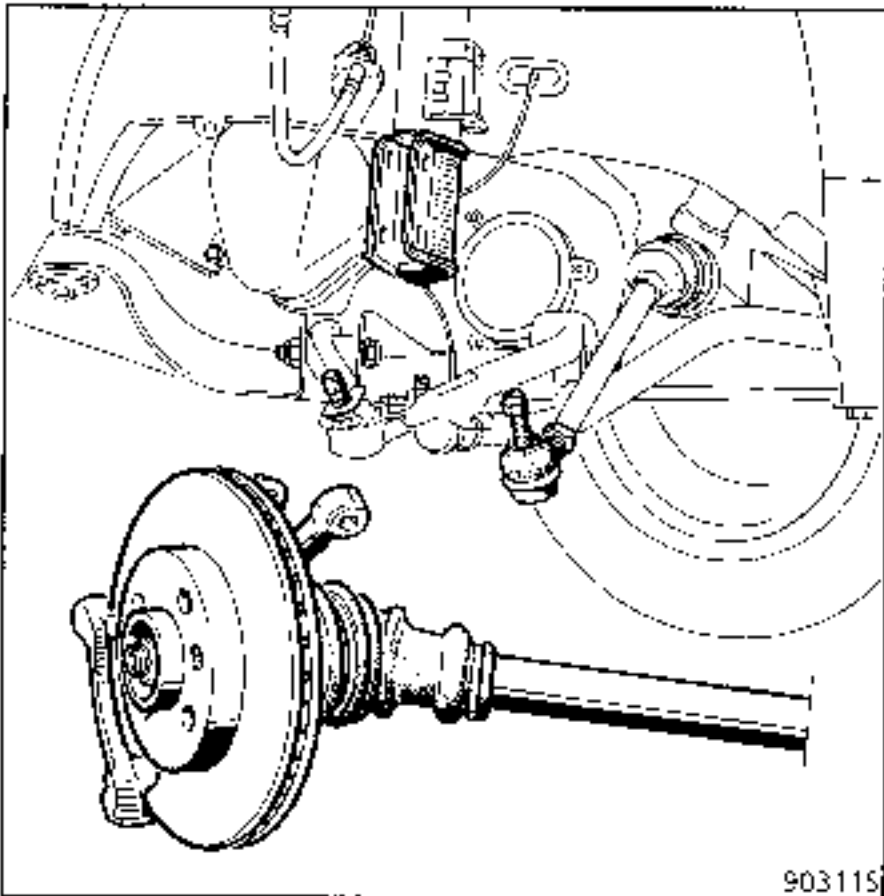

Check that the driveshaft rollers do not come out manually. If they do, on reassembly, check that the needles have not dropped into the gearbox.

On the right hand side of the vehicle, remove the driveshaft roll pins using tool B.Vi. 31-01.

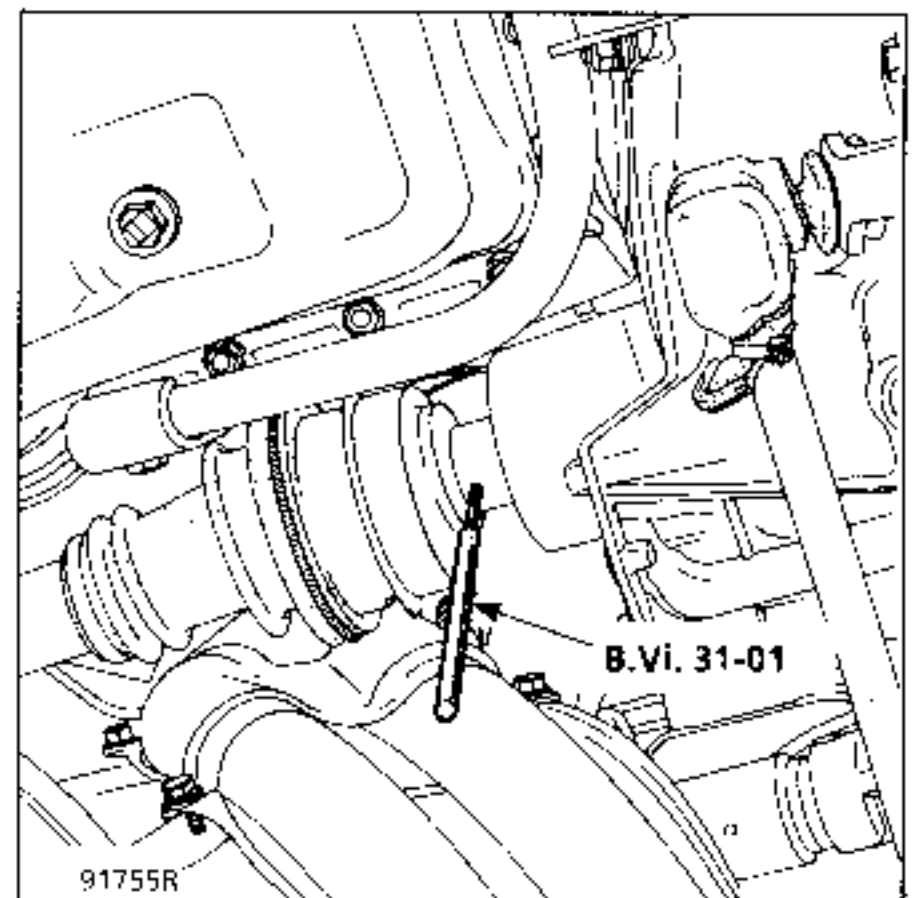

Slacken the lower shock absorber base bolt (3) and remove the upper bolt (4).

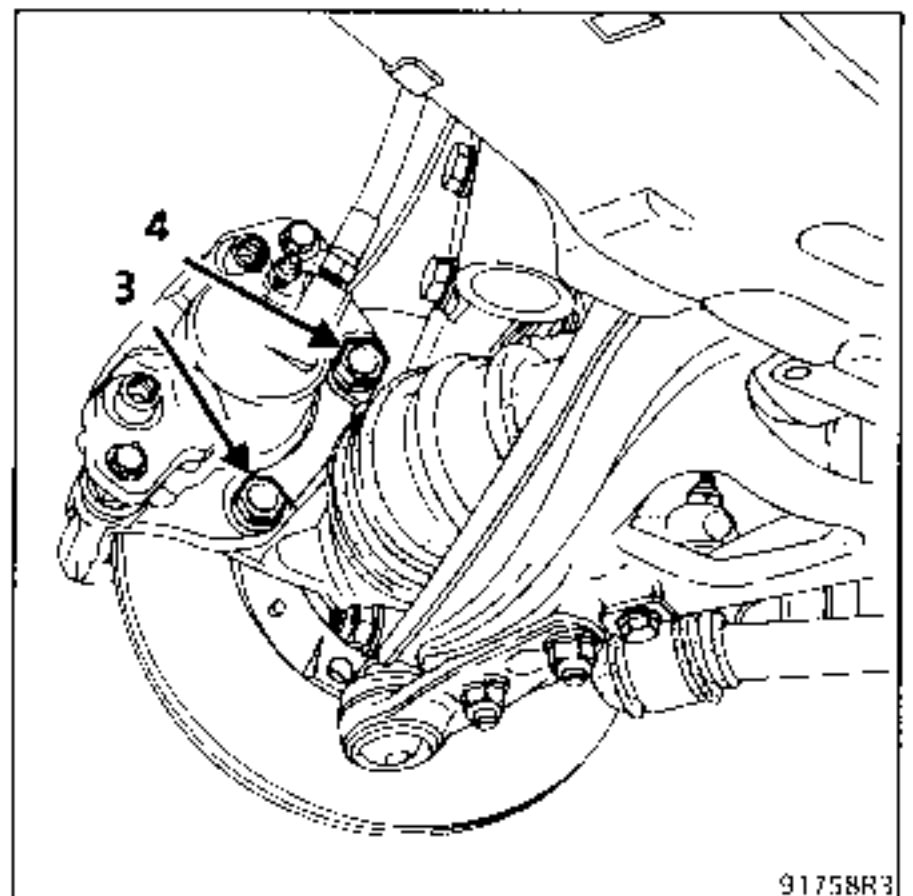

Tilt the stub axle carriers and release the driveshafts.

Under the vehicle, remove bolt (H) from the engine - gearbox tie rod and slacken the two side mounting bolts on the engine.

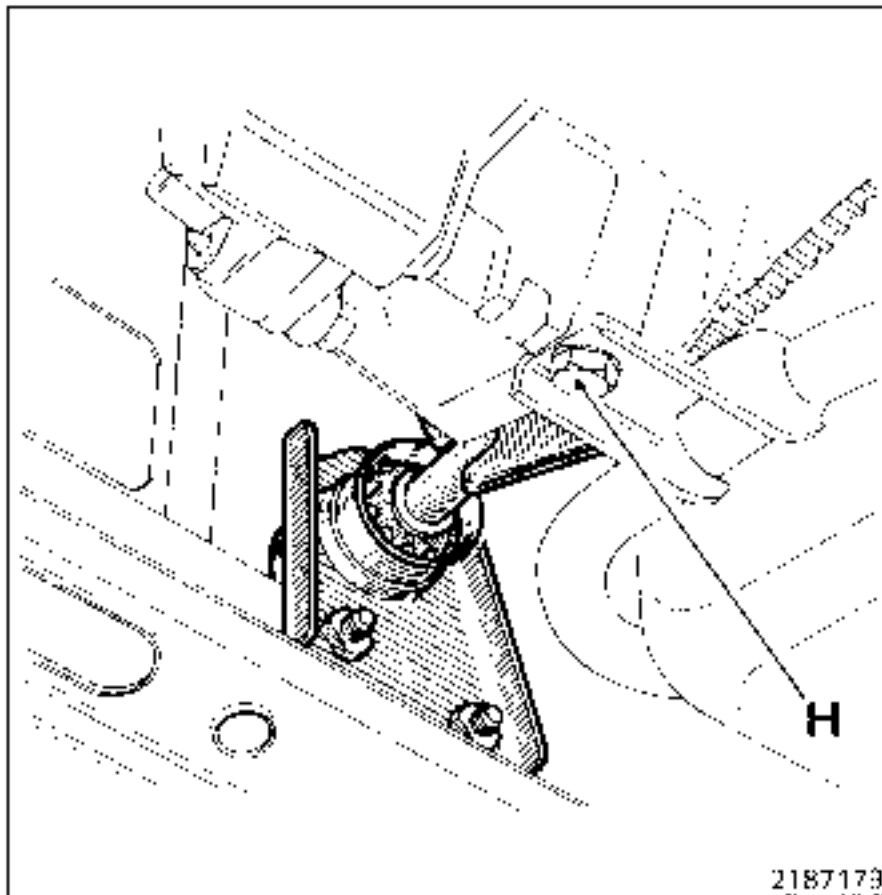

Remove:

- the movement limiter,
- the clutch protection plate,
- the gear control.

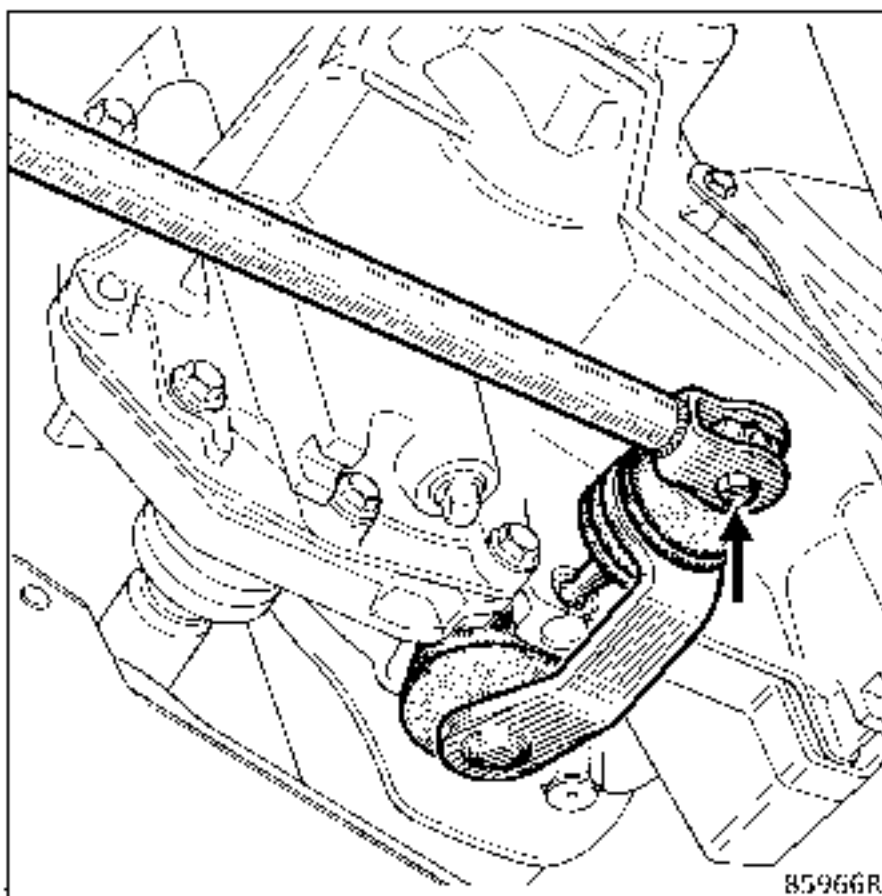

Disconnect:

- the clutch cable,

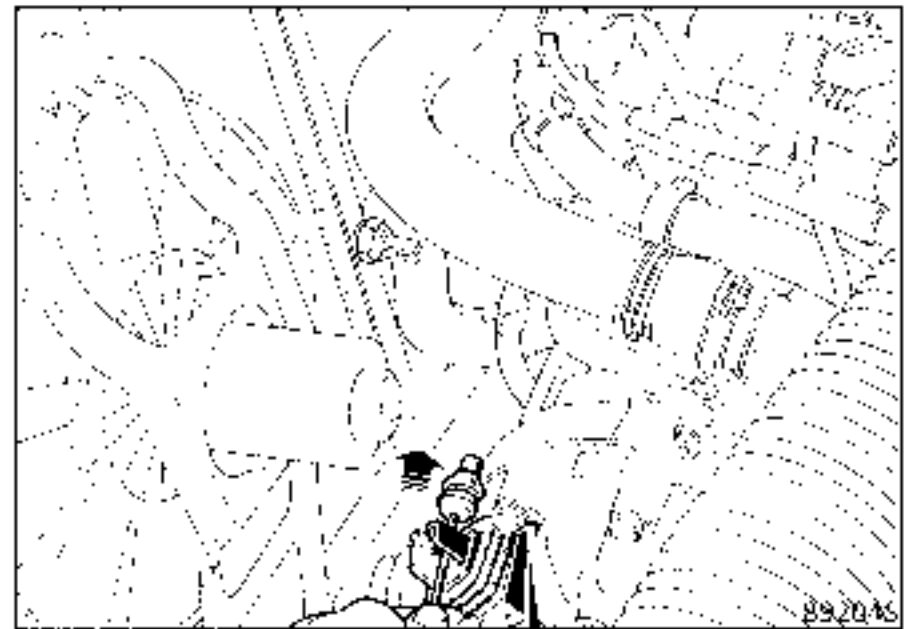

- the speedo cable and pin,

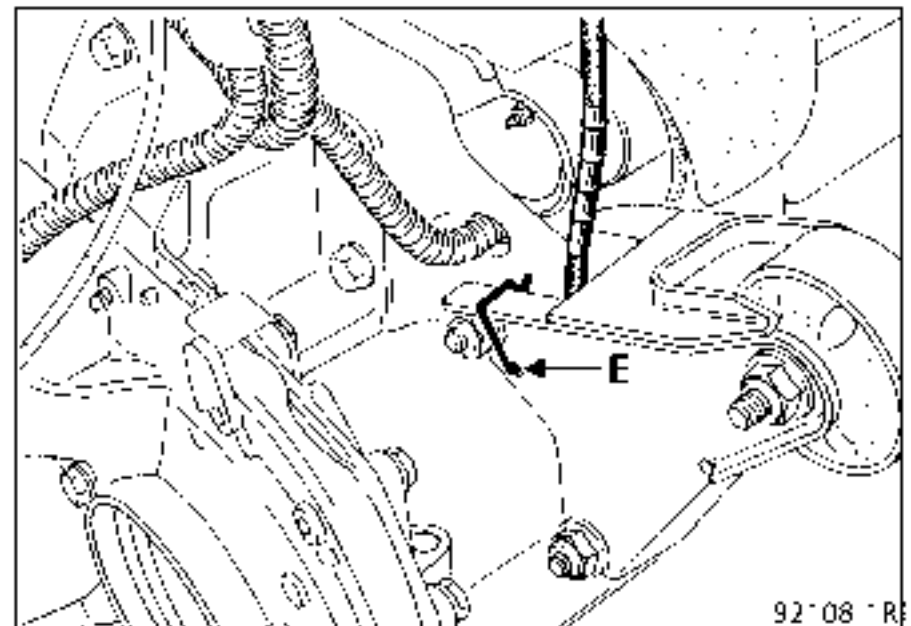

- the starter motor leads,
- the connector on the reversing lights switch,
- the TDC sensor.

"Petrol" engines - all types

Remove the air filter unit and plug the inlet apertures to the carburettor so that no foreign bodies may enter it.

Disconnect the choke cable from the carburettor.

On the cylinder head, remove the air filter mounting plate and in its place secure a locally made bracket to be used as a support.

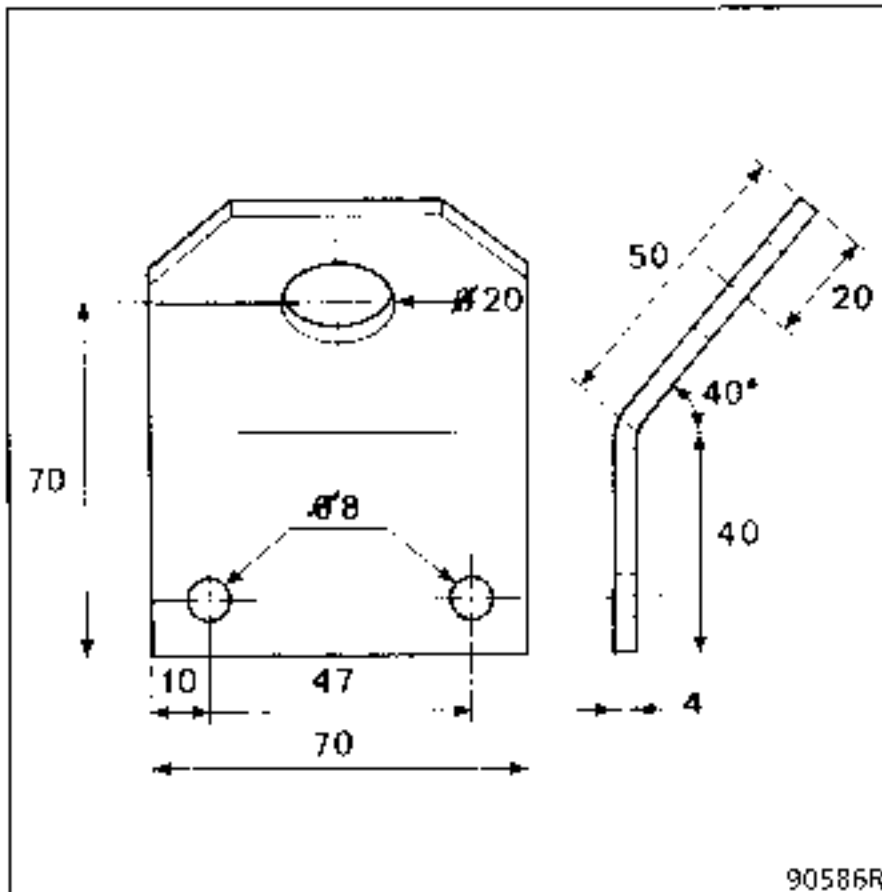

90586R

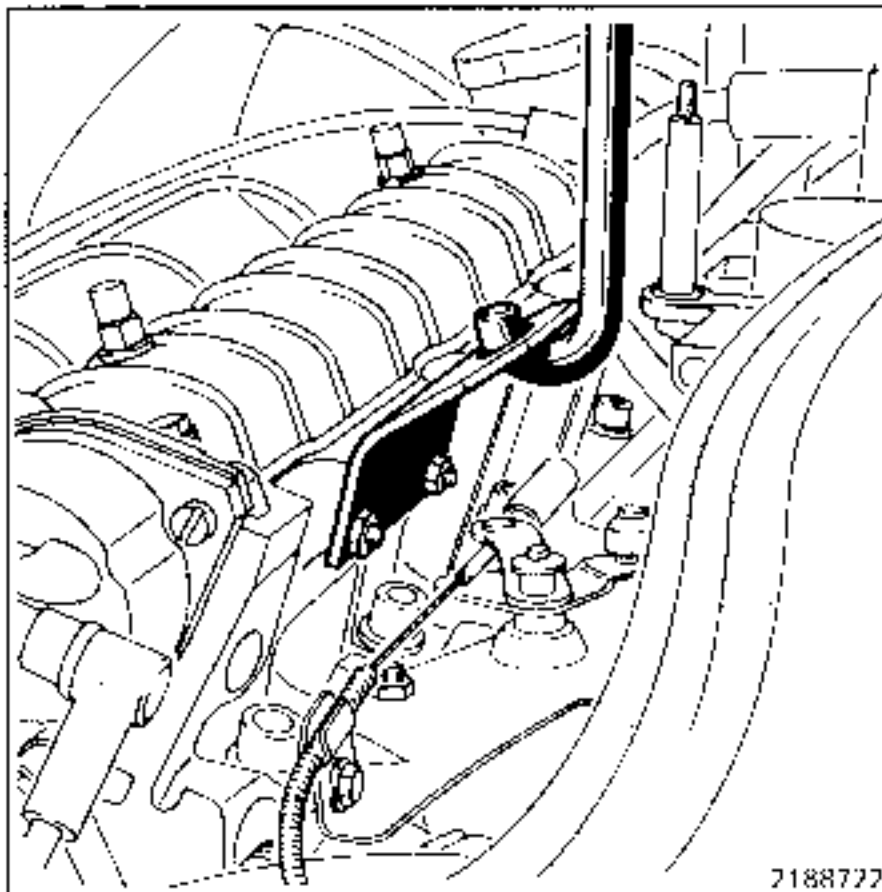

2188727

Remove:

- the mounting nut from the rear engine mounting pad.

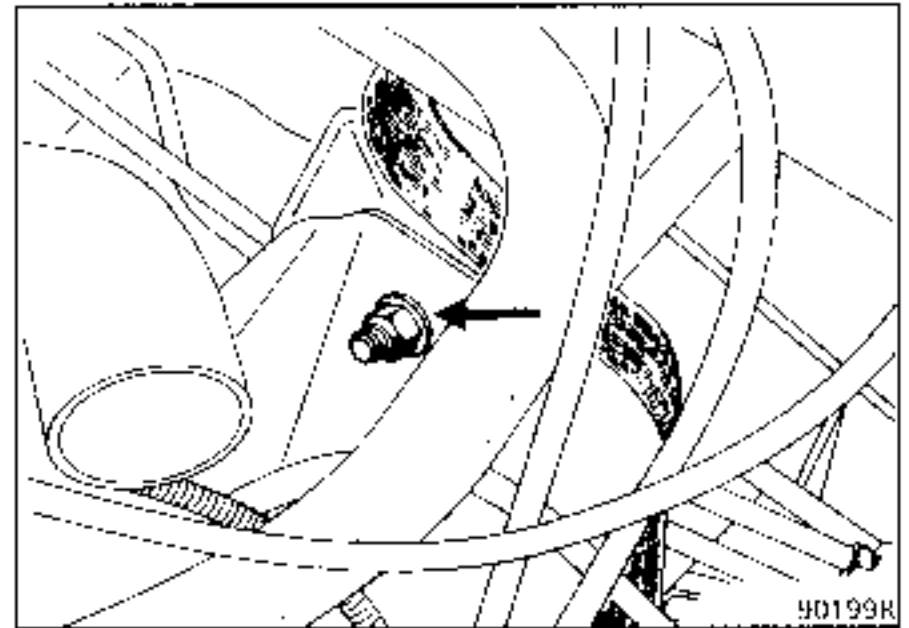

90199R

Using an engine support tool, lift the engine and remove the gearbox mountings.

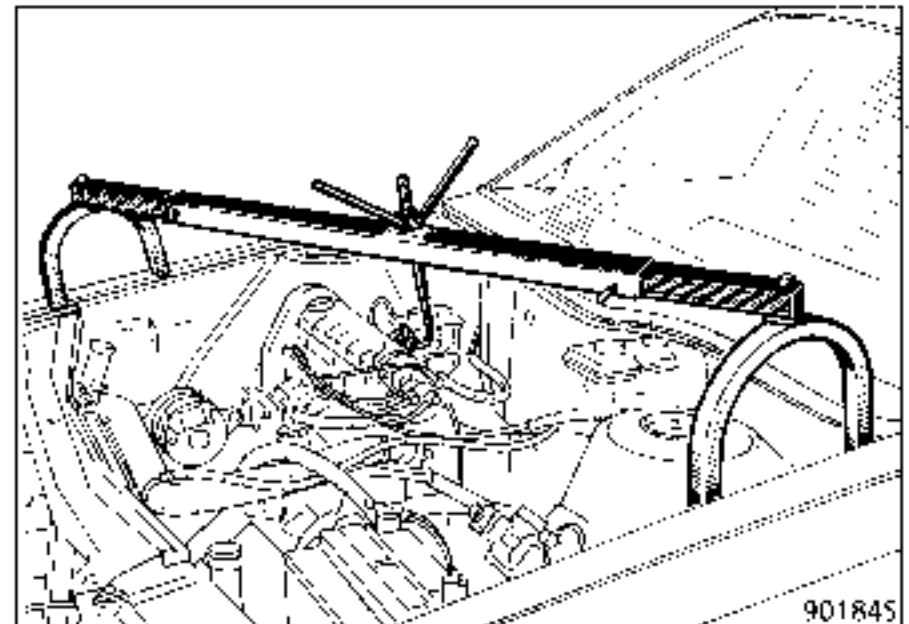

901845

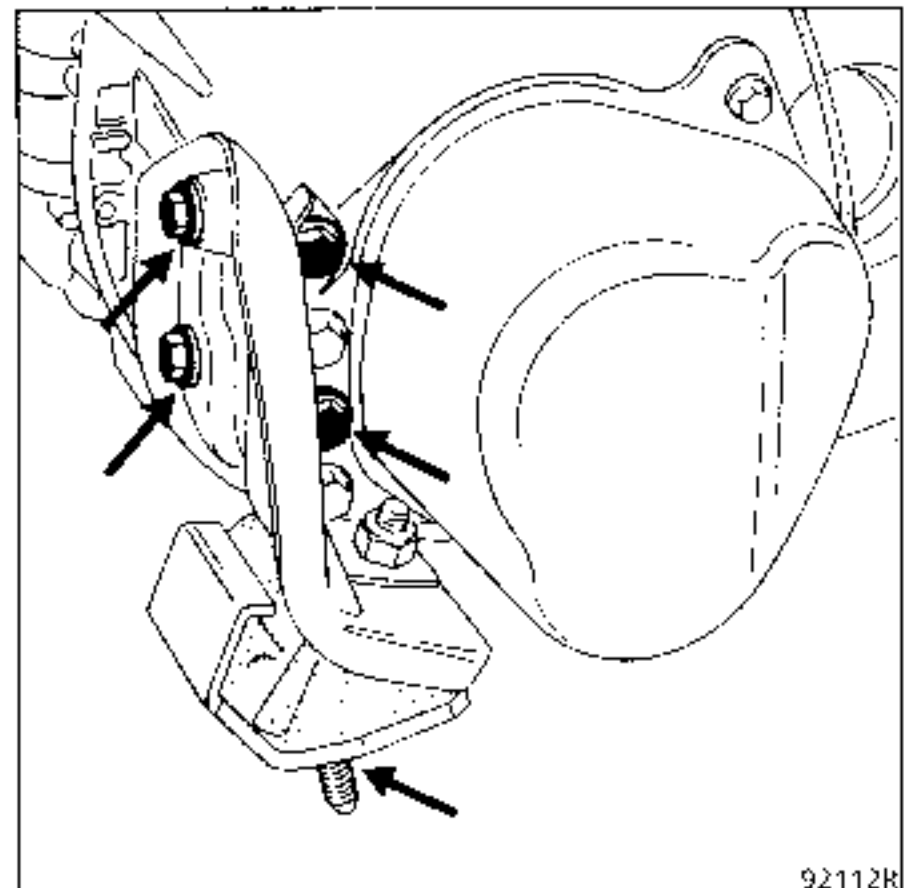

92112R

"Diesel" engines - special notes

Remove the air filter unit and its mounting.

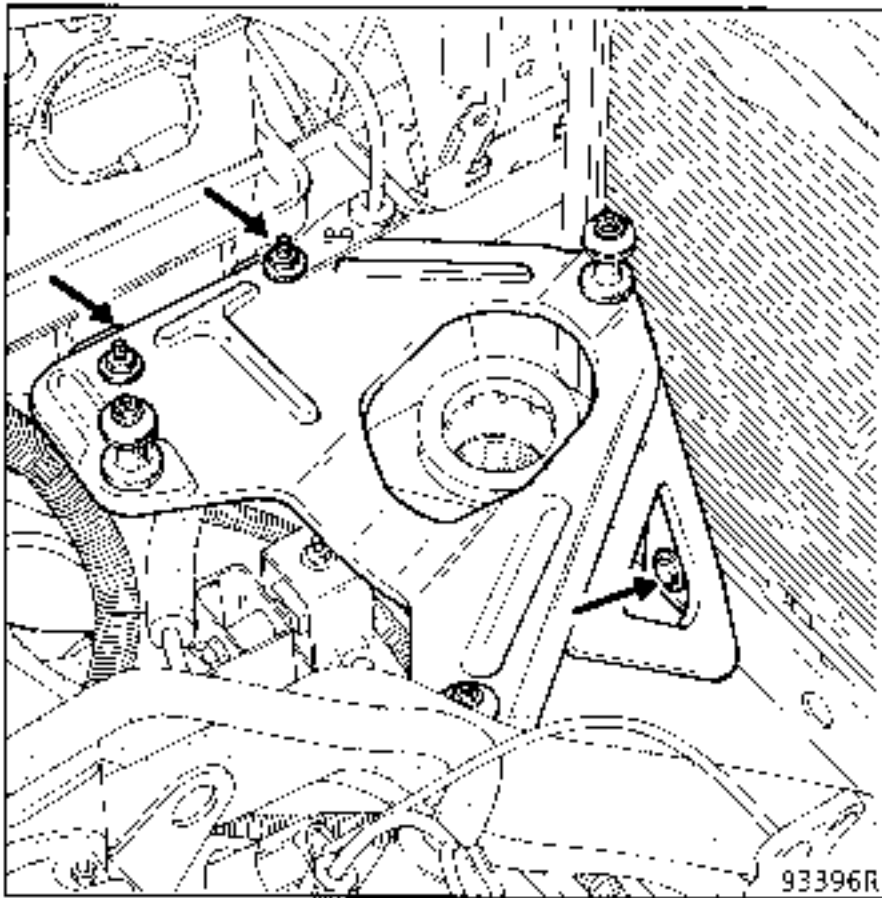

Release the coolant reservoir and the power assisted steering reservoir but do not disconnect the pipes.

Disconnect:

- the engine harness connector,
- the two connectors and the feed wire to the pre-postheating unit.

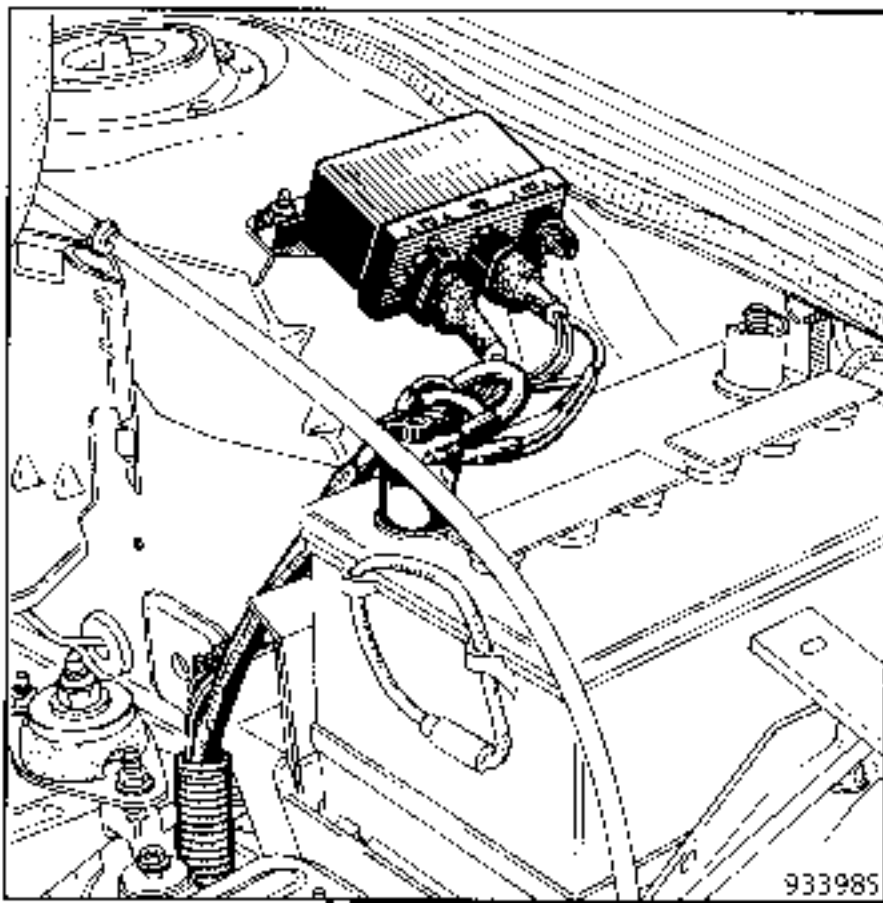

Lift the engine using an engine support tool.

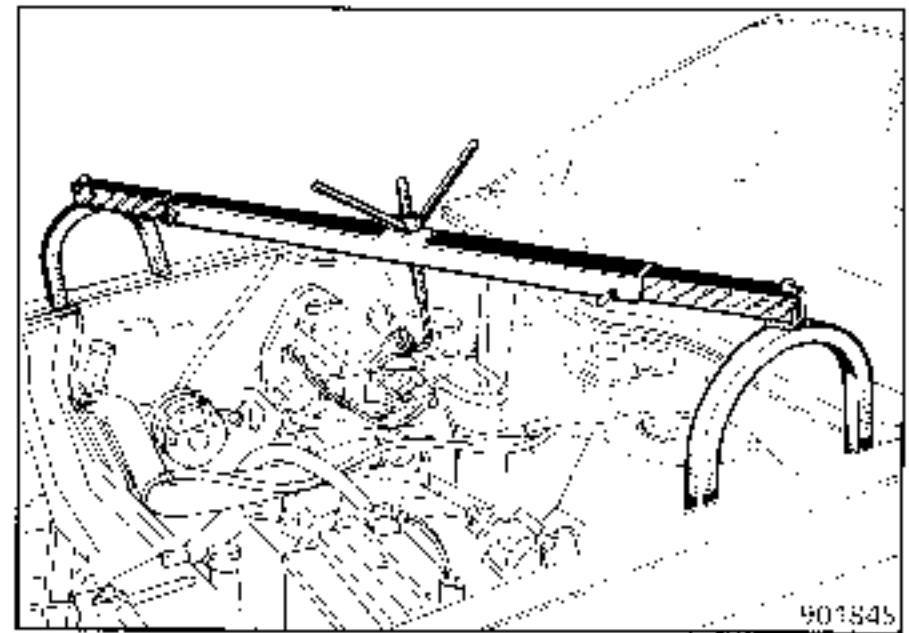

Remove:

- the front mounting,

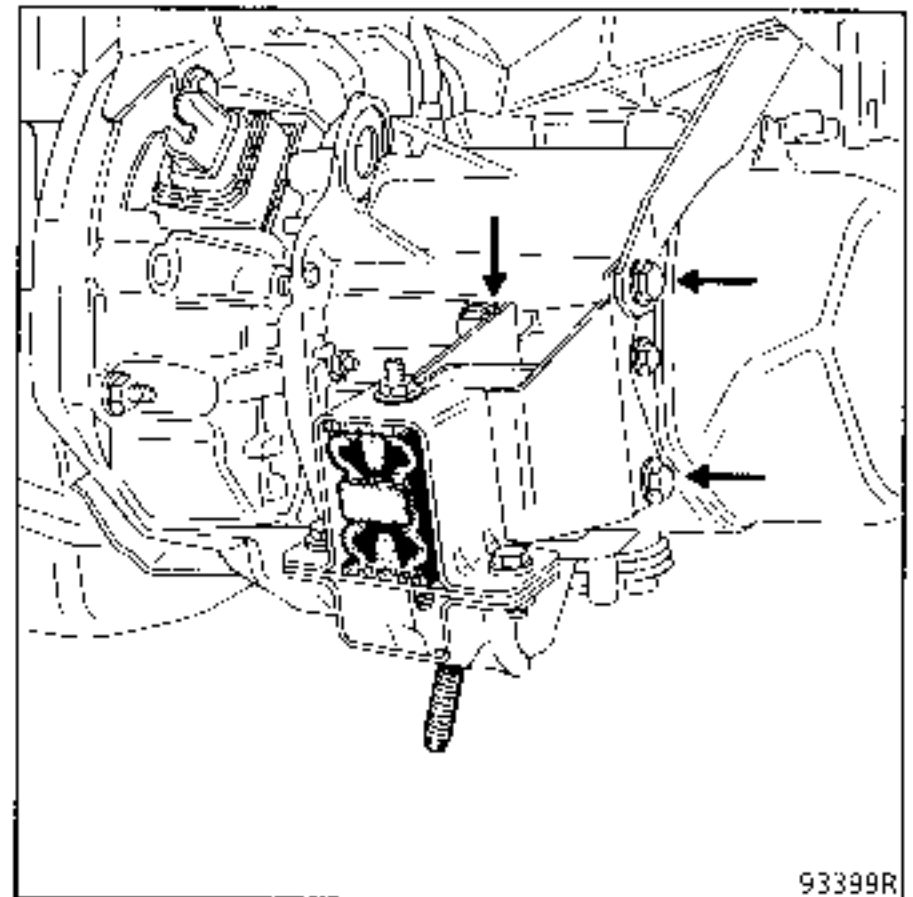

- the front left hand side shield (1 bolt and 3 rivets),

the upper mounting assembly,

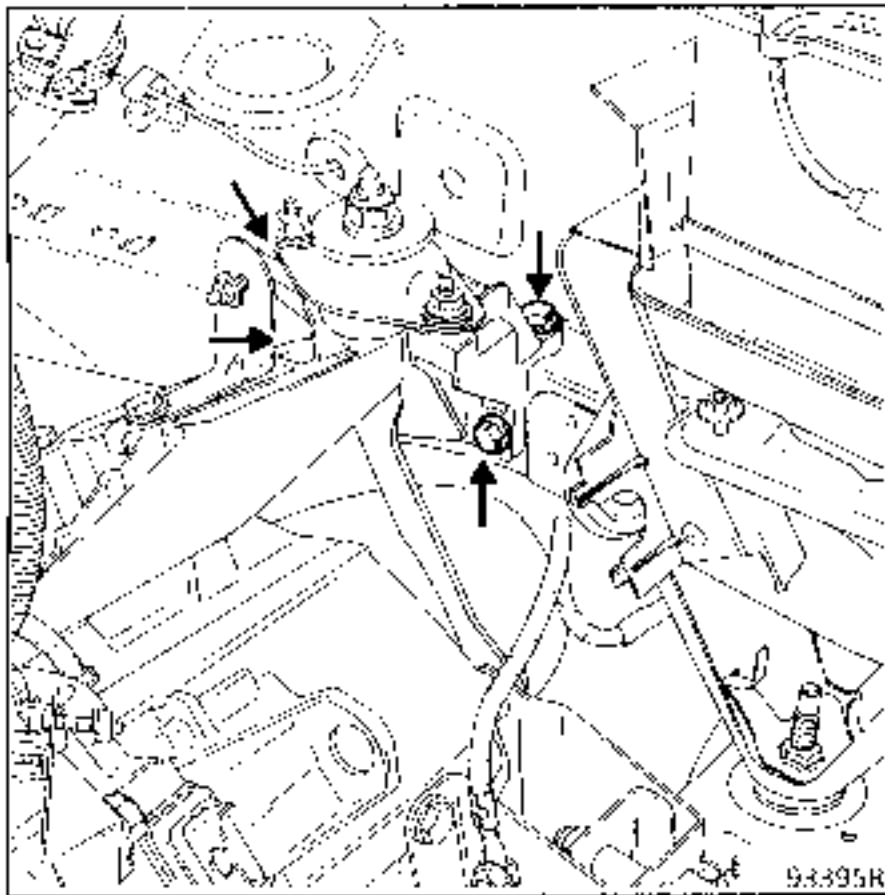

the three bolts from the rear centre mounting and remove the mounting.

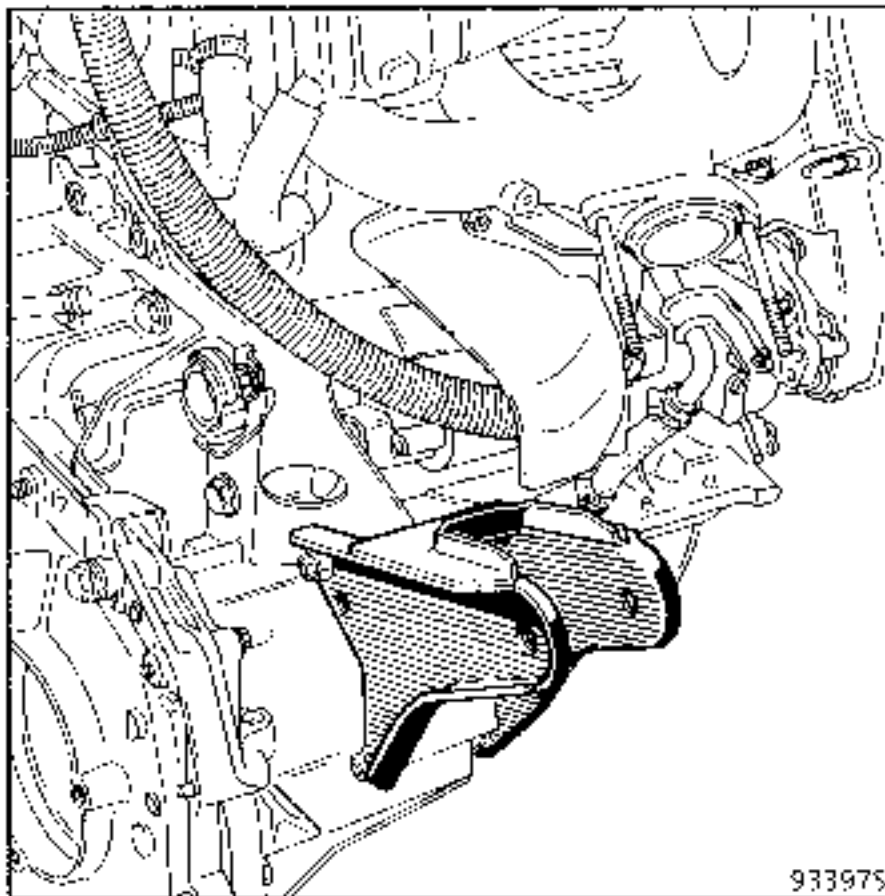

NOTE : to facilitate removal of the bolts, lift the gearbox slightly using a component jack.

Release the two side mounting bolts for the engine - gearbox tie rod.

Note: TORX bolt on starter motor side (T50 wrench).

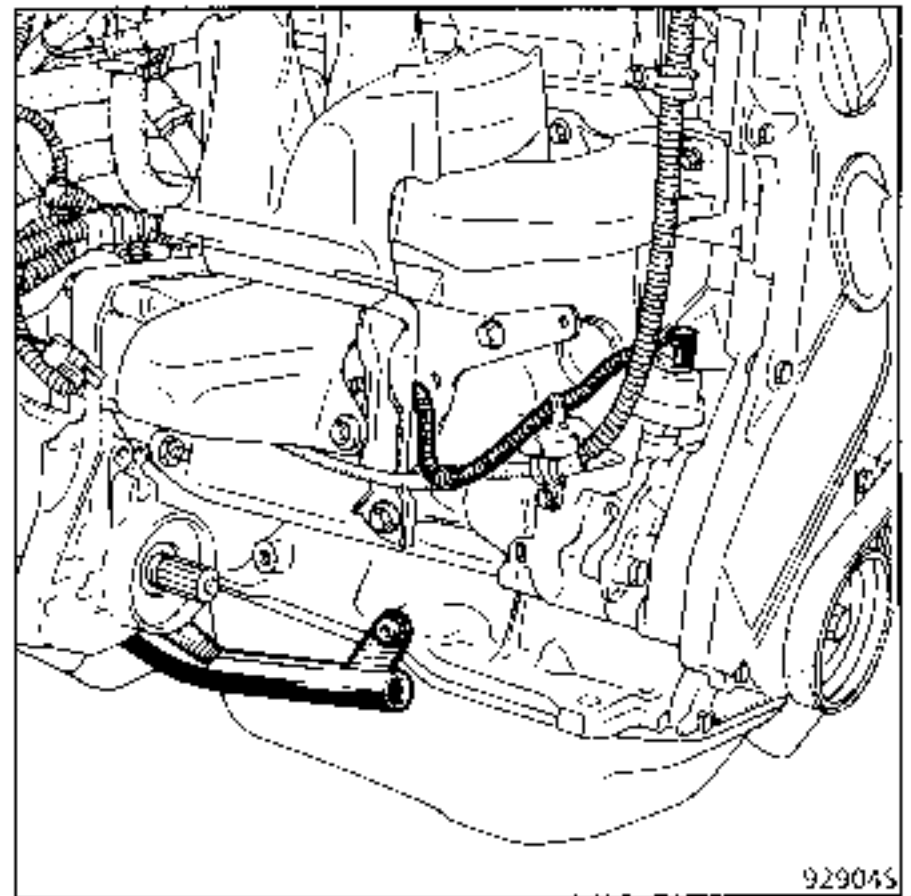

All types

Remove studs (A) and (B) using a nut and lock nut with an angled wrench and a ratchet.

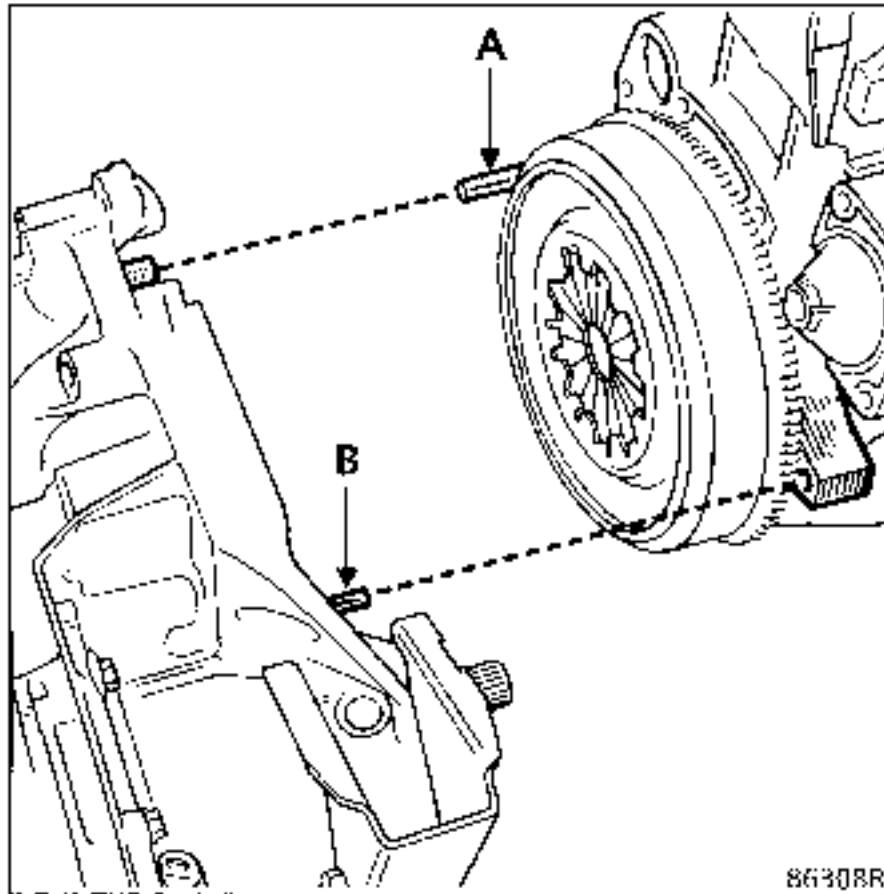

Remove:

the starter bolts,

- the bolts from the gearbox edge.

Release the gearbox from the engine by sliding the 5th gear housing between the vehicle side member and the sub-frame.

Lift the engine.

Gently pivot the gearbox forward to release the final drive section then remove the gearbox from the vehicle.

Attach the gearbox to a workshop crane, securing the fastening points to the clutch cable mounting bracket and to one bolt from the gearbox edge fitted in place of stud (B).

REFITTING - Special notes

Ensure the engine -gearbox centring rings are present and correctly positioned

- at A : gearbox assembled with a C type engine, long dowel,
- at B : gearbox assembled with an F type engine, short dowel.

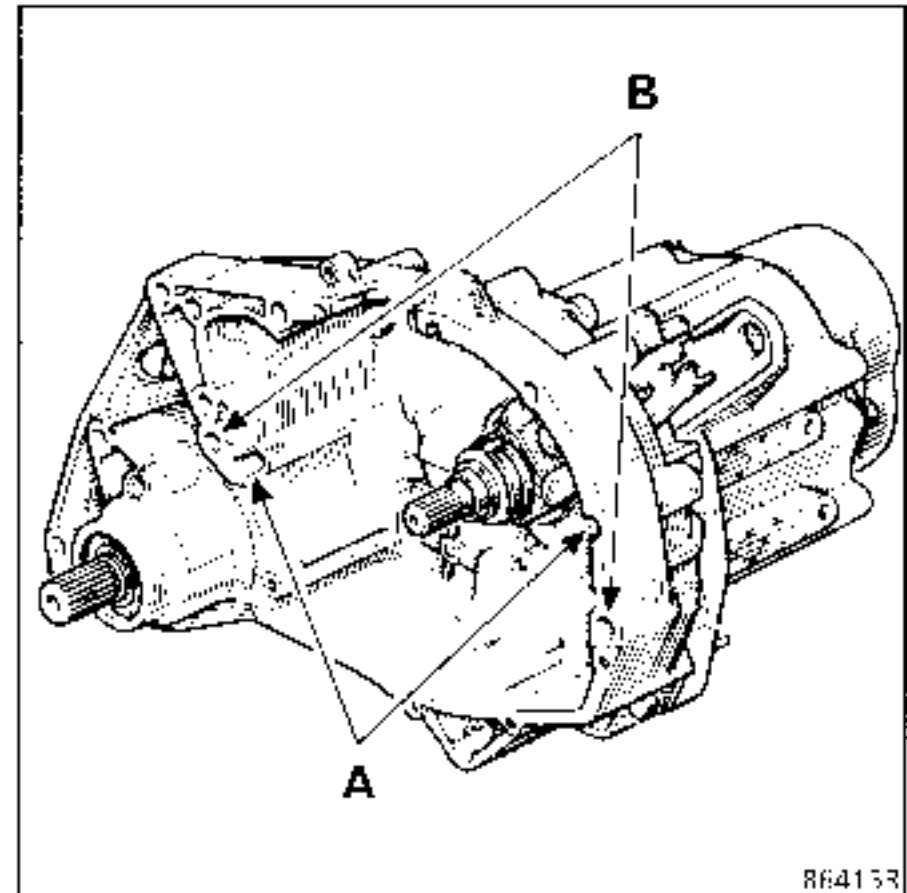

Coat the clutch shaft splines and the right hand sunwheel with **MOLYKOTE BR2**.

Special note for "diesel" clutch discs:

Diesel engines are fitted with a damping pre-hub which operates most efficiently when its internal components operate dry.

If there is an excess of grease on the hub and this grease penetrates into the damping pre-hub, it will no longer be efficient and gearbox noise will occur.

IMPORTANT

Bolt (V) and the starter motor centring dowel (D) must be fitted correctly.

The heat shields must be correctly refitted.

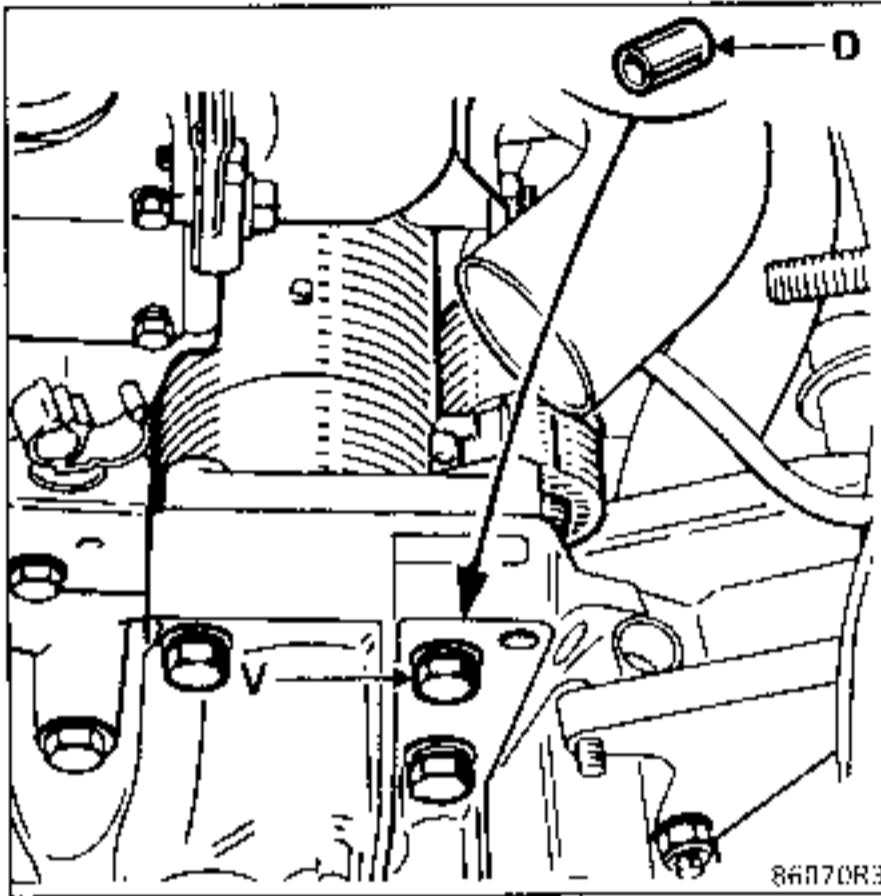
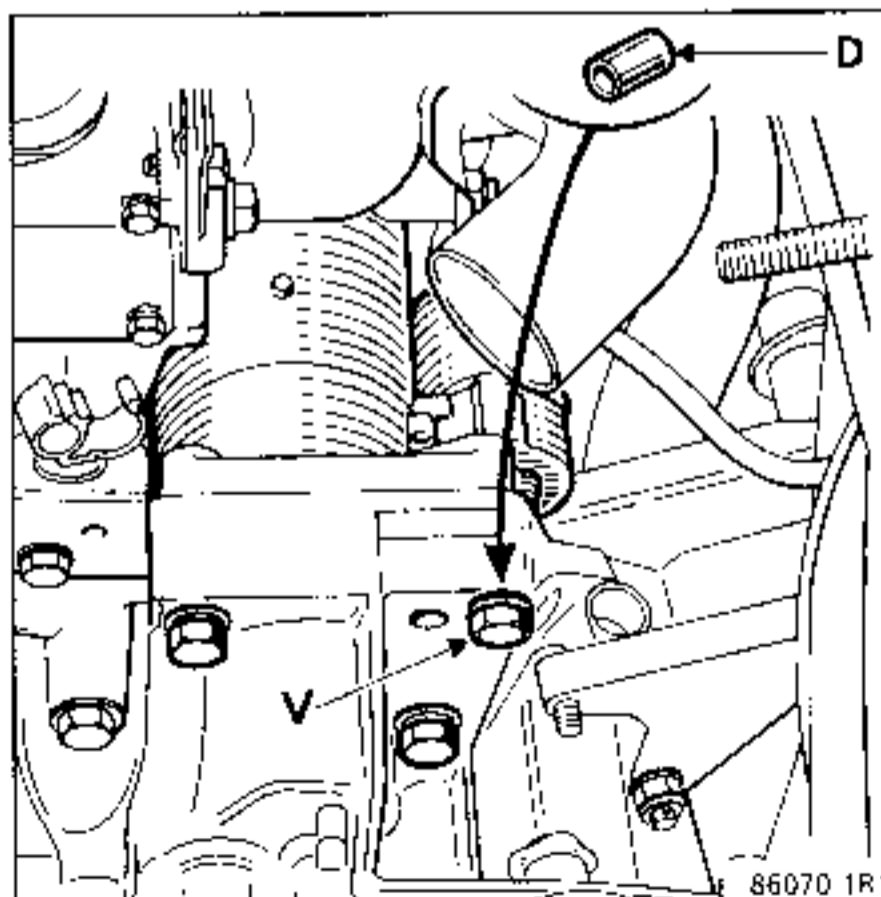
1 - C engine**2 - F engine**

Reconnect the speedo cable, ensuring the pin is fitted correctly.

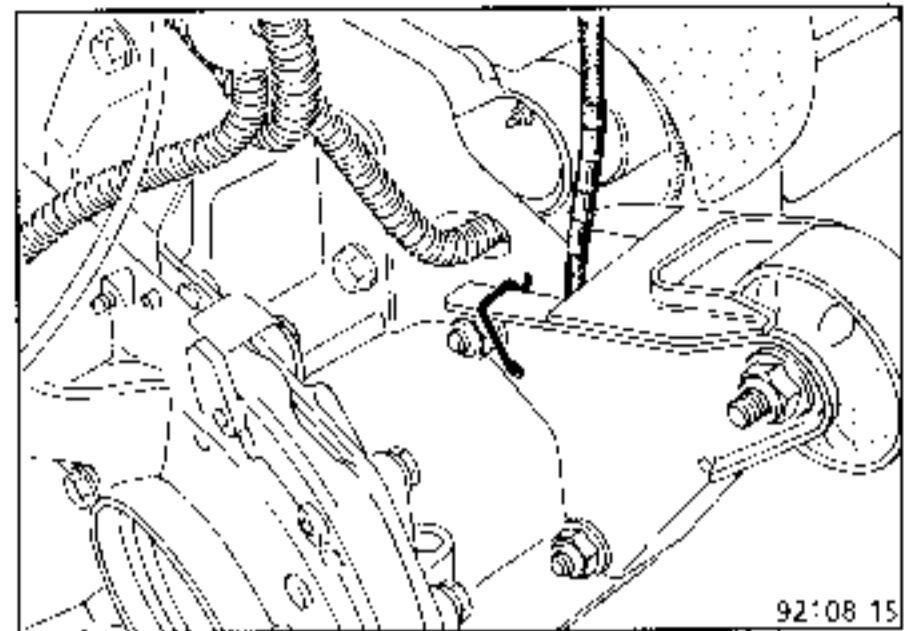

Position the driveshaft in relation to the sunwheel, pivot the stub axle carrier, engaging the driveshaft into the sunwheel using the angled pin B.Vi. 31-01 to align the holes.

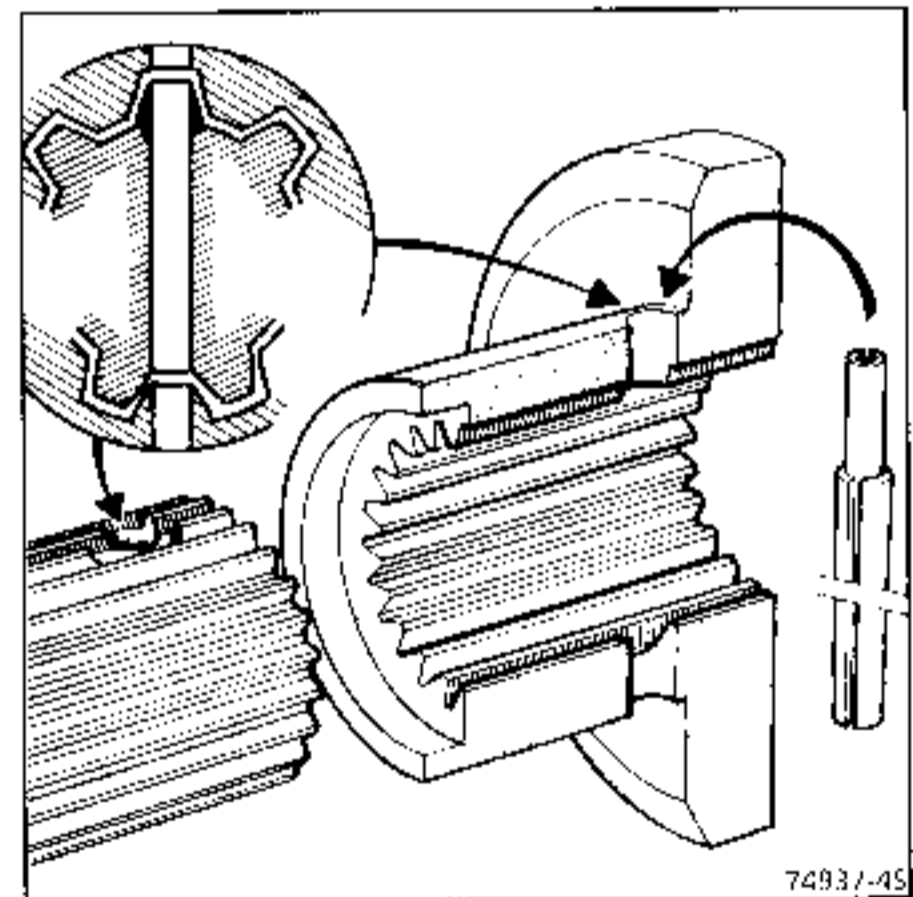

An input chamfer on the sunwheel makes fitting the new roll pins easier.

Seal the ends with (RHODORSEAL 5661).

Fit the caliper mounting bolts with **LOCTITE FRENBLOC** and tighten to the correct torque.

Press the brake pedal several times to bring the pistons into contact with the brake pads.

 Tighten all nuts and bolts to the correct torque

Fill the gearbox with oil.

SPECIAL TOOLING REQUIRED

B.Vi.	31-01	Set of punches
T.Av.	476	Ball joint extractor

TIGHTENING TORQUES (in daN.m)



Mounting pad nuts	4
Wheel bolts	9
Shock absorber base mounting bolt	20
Track rod end nut	4
Clutch bellhousing mounting bolt on engine	5

The gearbox is removed alone.

REMOVAL

Put the vehicle on a lift.

Disconnect the battery.

Remove the front wheels.

Drain the gearbox if necessary.

Remove the driveshaft roll pins using tool B.Vi. 31-01.

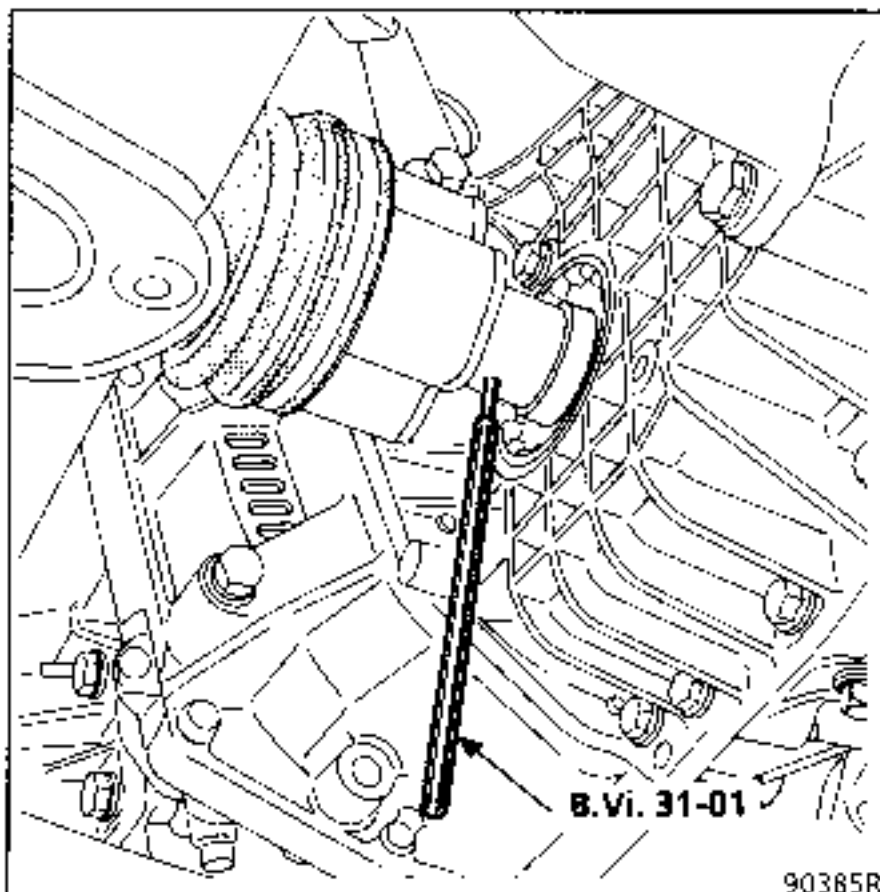

Remove:

- one track rod end using tool T.Av. 476,

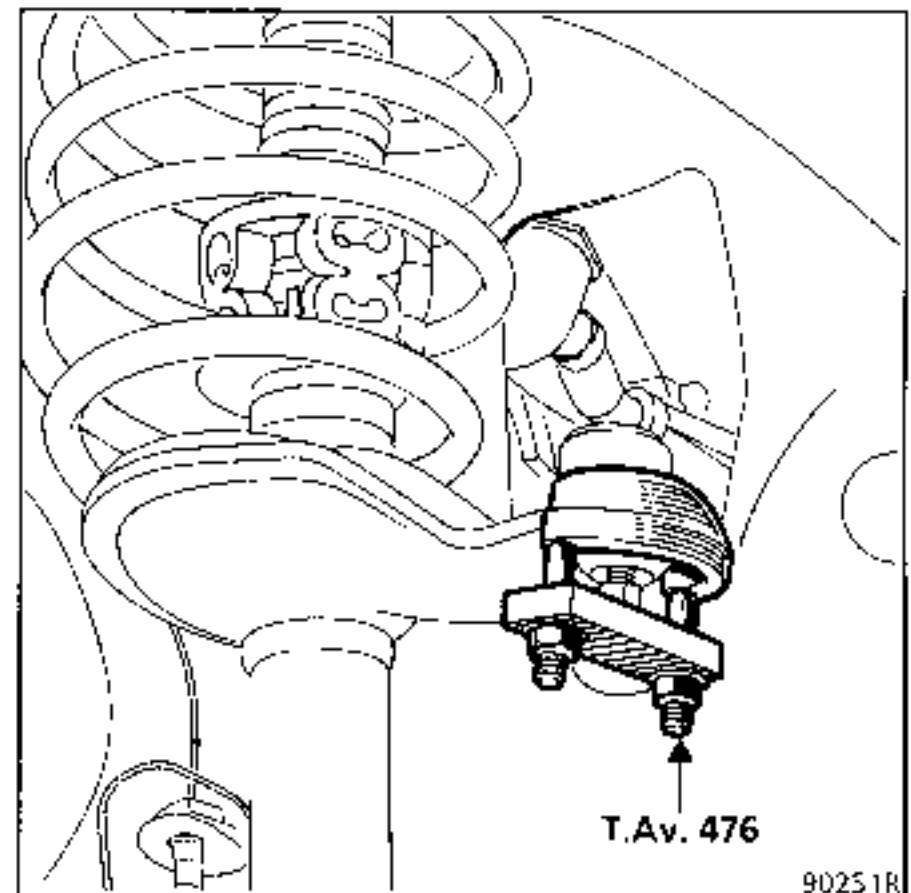

- the upper shock absorber base mounting bolts (1) and slacken the lower bolts (2).

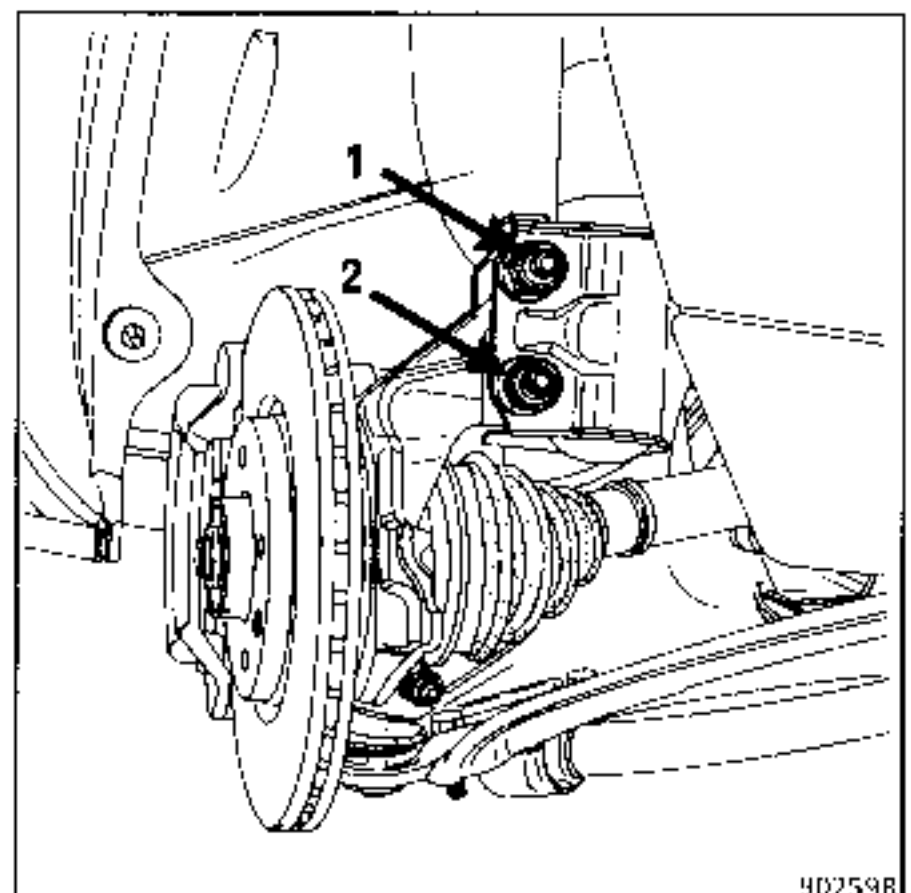

NOTE : the bolts have a splined section and a mallet must be used to remove them.

Tilt the stub axle carriers and release the driveshafts.

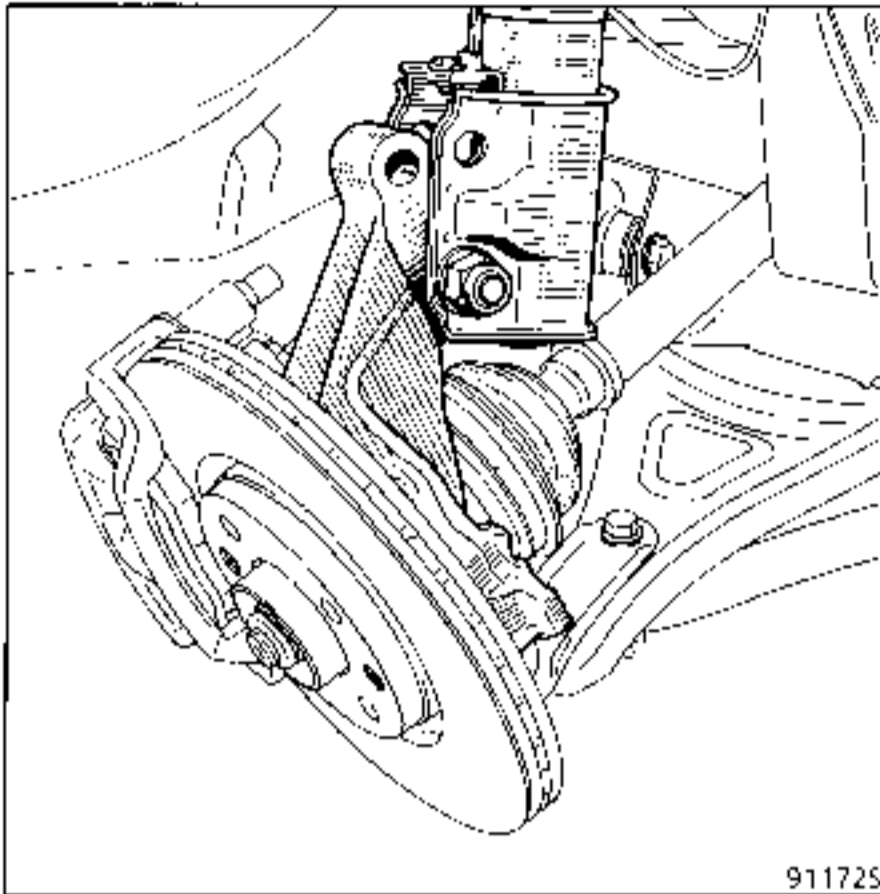

Remove:

- the upper bolts at the edge of the gearbox,
- the starter motor bolts.

Under the vehicle, remove:

- the transverse bar,
- the primary exhaust pipe,
- the selector controls (the two mounting bolts (A) and release ball joint (B)),
- the reverse gear locking device (V).

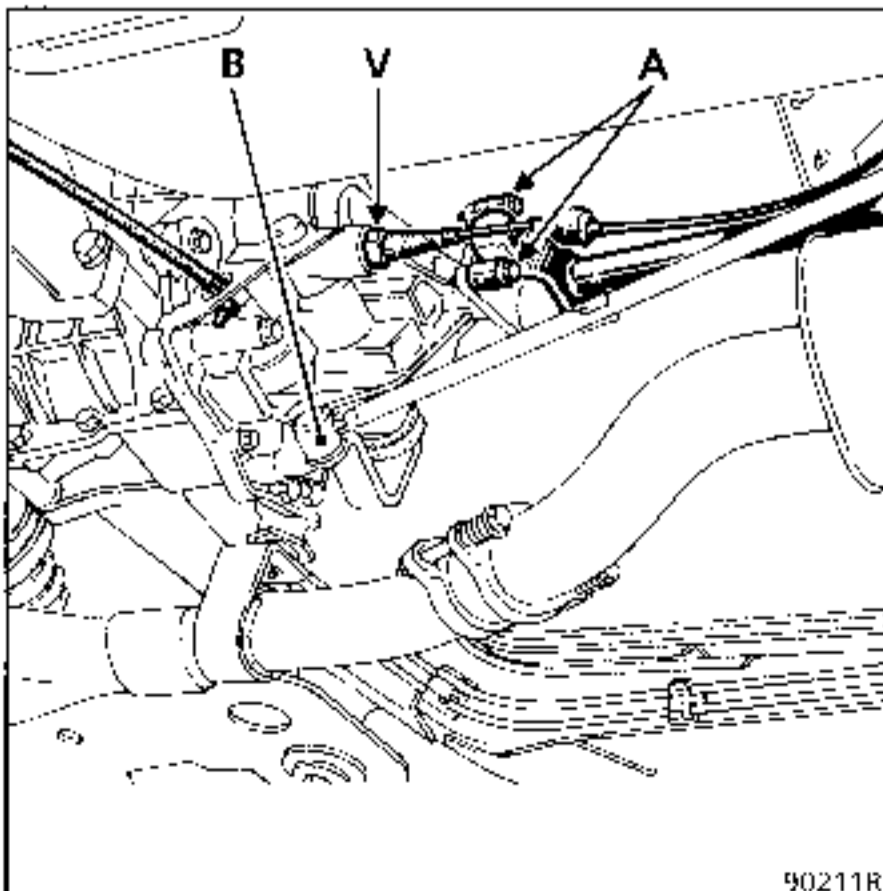

Remove:

- the earth strap,
- the lower bolts at the edge of the gearbox.

Disconnect:

- the clutch cable,
- the reversing lights switch wires,
- the speedo cable.

Petrol engine - Special note

Remove the primary exhaust pipe.

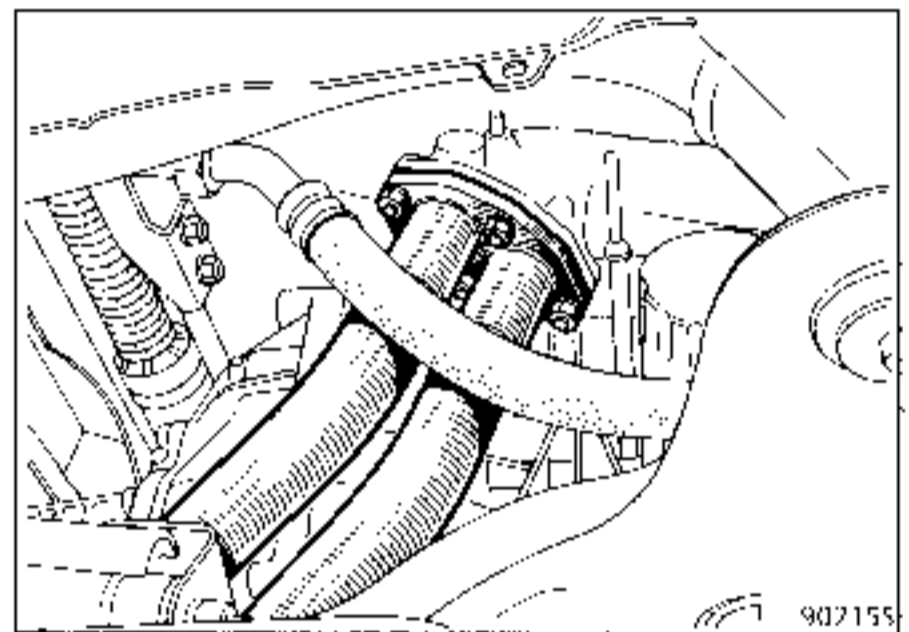

All types

Position the component jack.

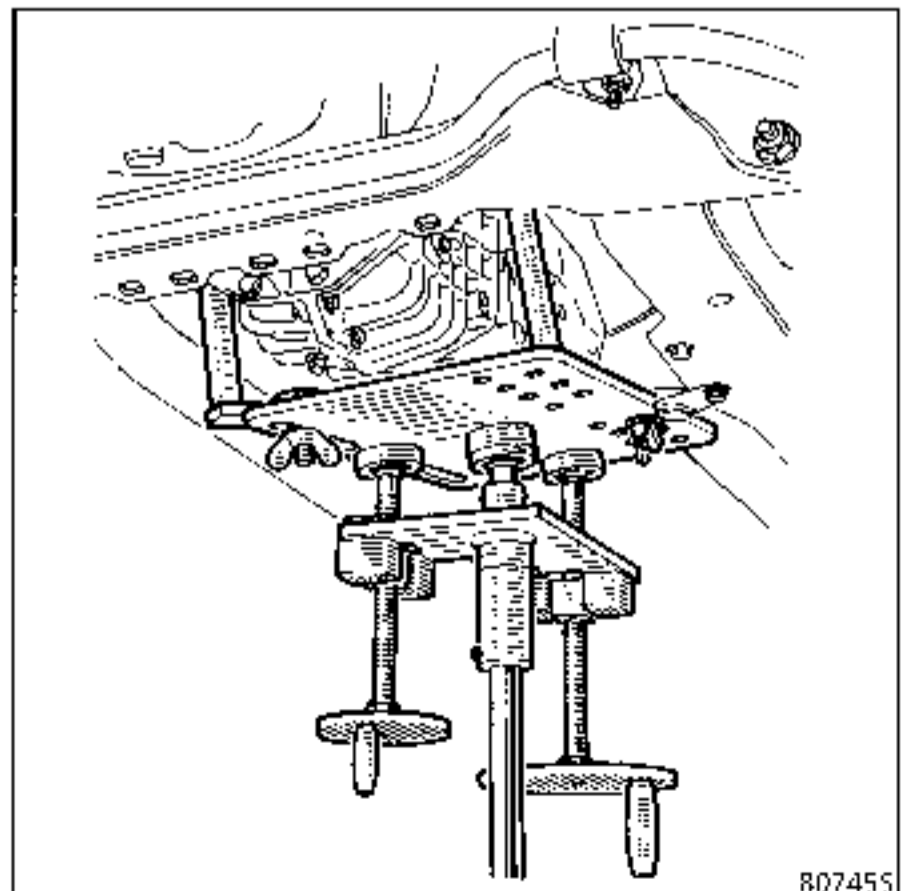

Remove the side pad mounting assemblies from the gearbox (bolts A).

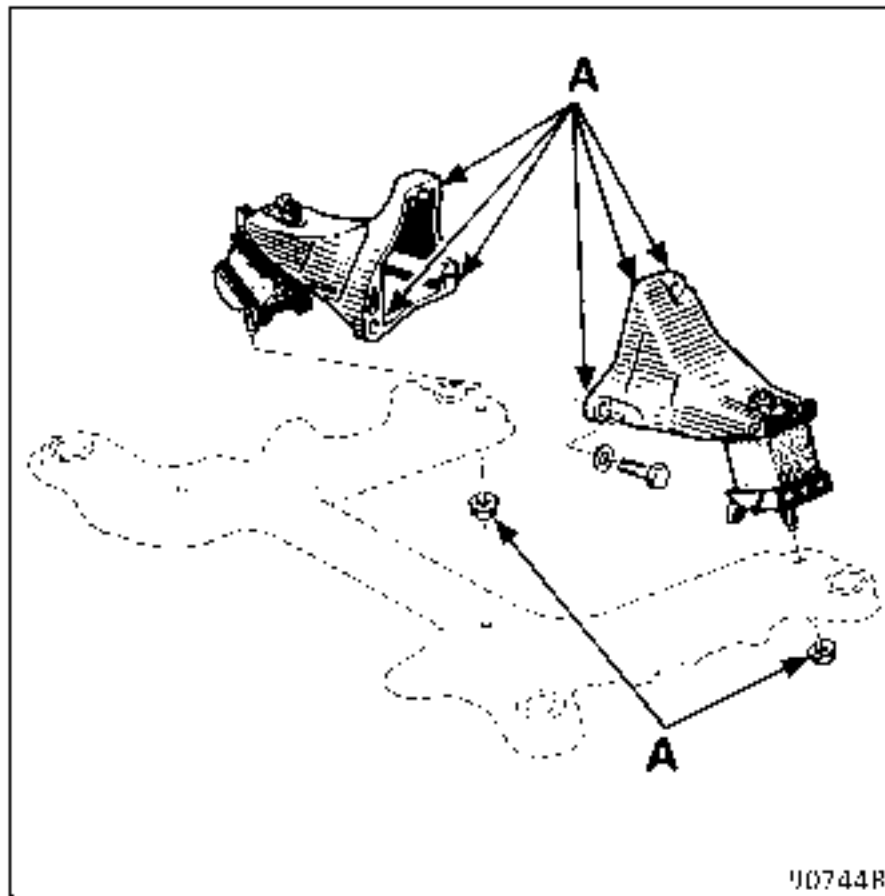

90744R

Lift the engine slightly at the front.

Pull the gearbox towards the rear of the vehicle, taking care not to catch the clutch fork control.

REFITTING - Special notes

Before refitting the gearbox to the vehicle, check the centring dowels (A), (B) are present on the engine block and dowel (C) is present on the starter motor.

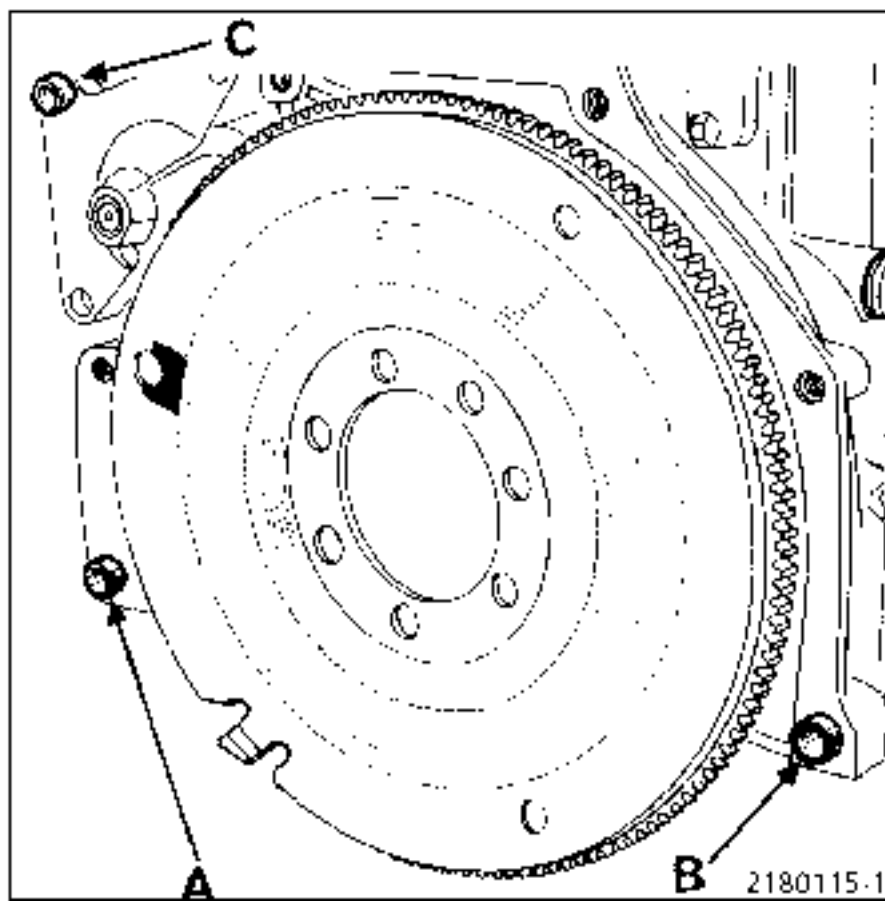

2180115-1

Special note for "diesel" clutch discs:

Diesel engines are fitted with a damping pre hub which operates most efficiently when its internal components operate dry.

If there is an excess of grease on the hub and this grease penetrates into the damping pre-hub, it will no longer be efficient and gearbox noise will occur.

Drawn clutch - Special note

Fit the gearbox in position, ensuring that the clutch fork fingers are correctly positioned behind the thrust pad shoulder (the thrust pad is integral with the clutch mechanism).

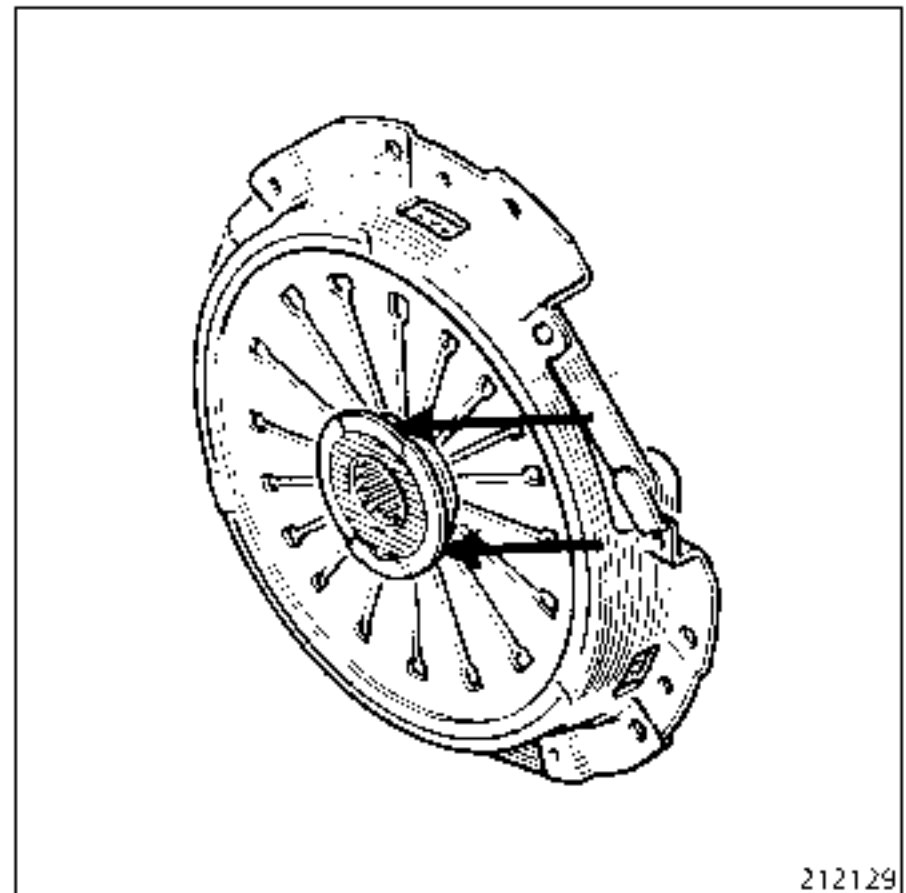

212129

NOTE : when the parts are fitted , moving the fork (without any excessive play) and the gearbox simultaneously enables you to ensure that the fork fingers are correctly positioned.

Assemble the gearbox and engine and refit the side mountings.

Ensure the rubber washer (R) is fitted which must be placed between the end of the sunwheel (P) and the base of the driveshaft yoke.

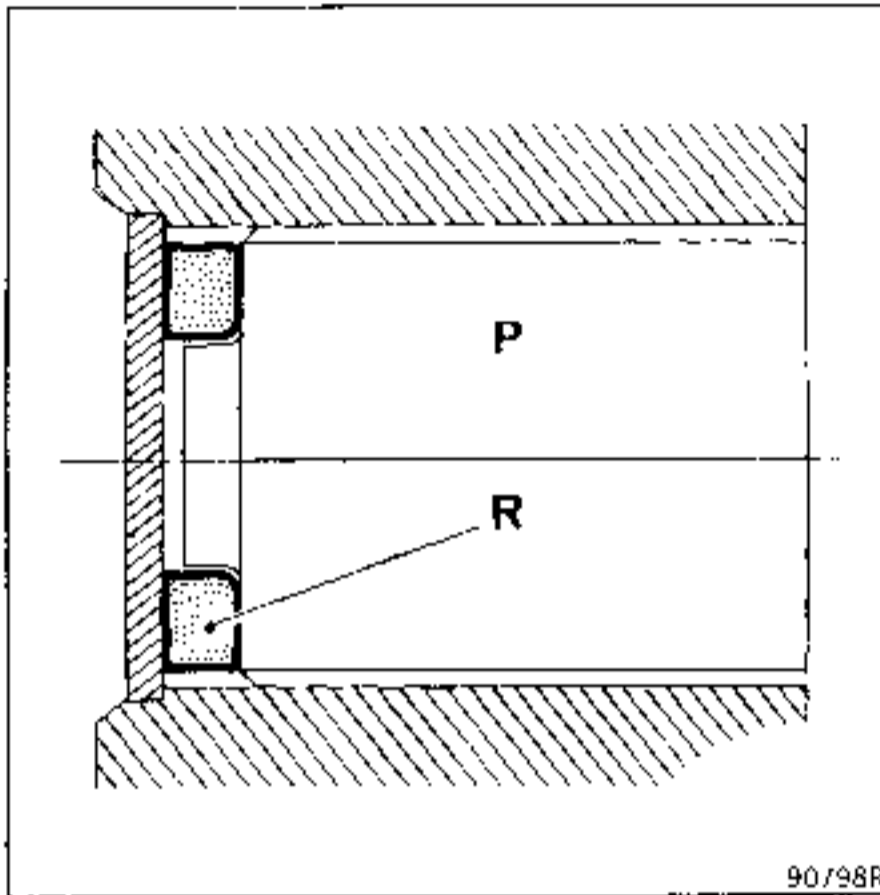

Position the driveshaft in relation to the sunwheel, pivot the stub axle carrier, engaging the driveshaft into the sunwheel using the angled pin B.Vi. 31-01 to align the holes.

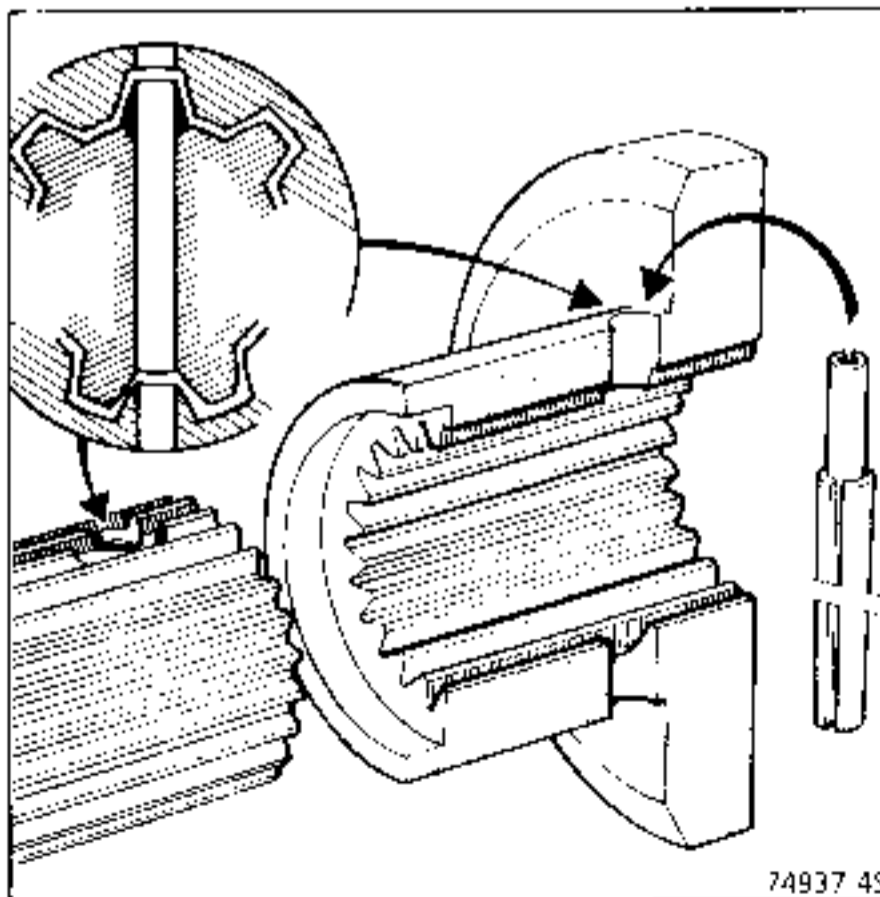

An input chamfer on the sunwheel makes fitting the new roll pins easier.

Seal the roll pin holes (RHODORSEAL 5661).

"Petrol" engine

Refit the exhaust flange

NOTE : the exhaust flange has spacers (1) which determine the spring tension. Tighten the flange until the spring is against the spacers.

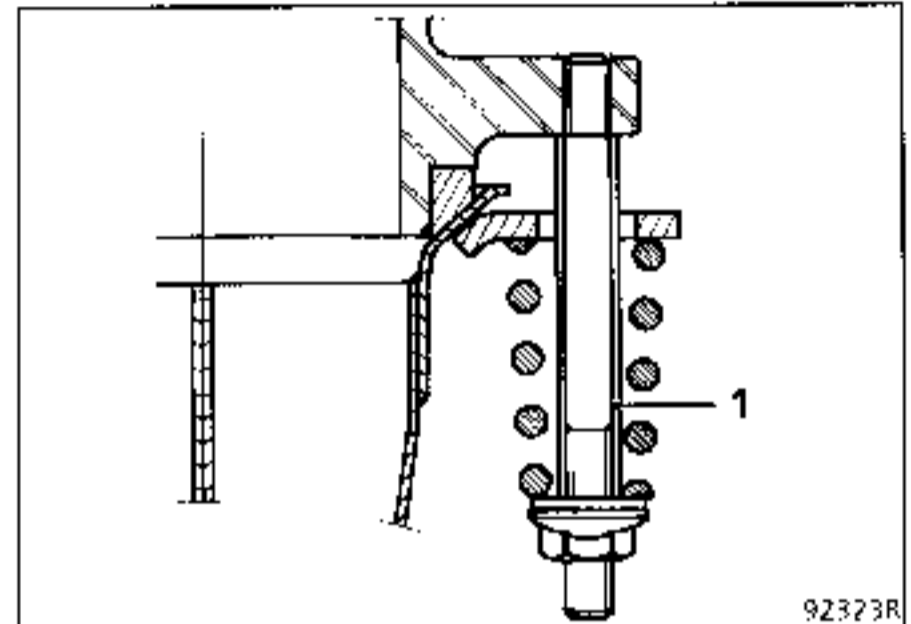

Refit:

- the gear selector controls,
- the speedo cable,
- the transverse bar,
- the earth strap.

Reconnect the clutch cable and check that the automatic wear take-up system is operating correctly.

- ⊖ Tighten all nuts and bolts to the correct torque.

Fill the gearbox with oil if necessary.

Special notes and additional information to the method given for 4 x 2 vehicles (NG9)

TIGHTENING TORQUES (in daN.m)	
Bolt on output flange	2.5

REMOVAL

Remove:

- the catalytic converter (if necessary).
- the prop shaft.

Disconnect:

- the two pipes from the differential lock pneumatic control,
- connector (C) from the differential lock warning light switch,
- the reverse gear locking device.

Use a standard wrench, modified in the workshop to give better access for this operation.

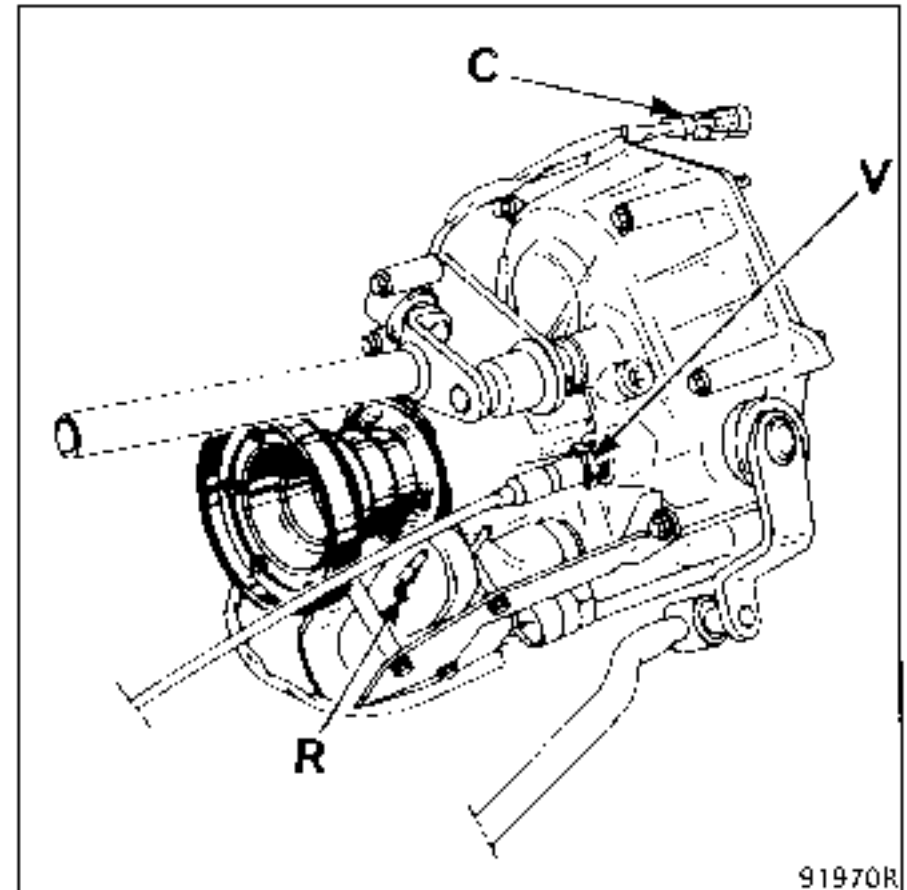

REFITTING

Special note



Tighten all nuts and bolts to the correct torque.

Ensure the differential lock pneumatic control pipes are correctly connected:

the red pipe must be connected to the marked side (red label (R)) on the vacuum capsule.

SPECIAL TOOLING REQUIRED

B.Vi.	606	Set of punches
T.Av.	476	Ball joint extractor

TIGHTENING TORQUES (in daN.m)



Pad mounting nut	4
Wheel bolts	10
Shock absorber base mounting nut	20
Track rod end nut	3.5
Gearbox edge mounting bolt	5

The gearbox is **removed alone**.

REMOVAL

Put the vehicle on a lift.

Disconnect the battery

Remove the front wheels.

Remove the oil recuperator.

Drain the gearbox.

Remove the driveshaft roll pins (tool **B.Vi. 606**).

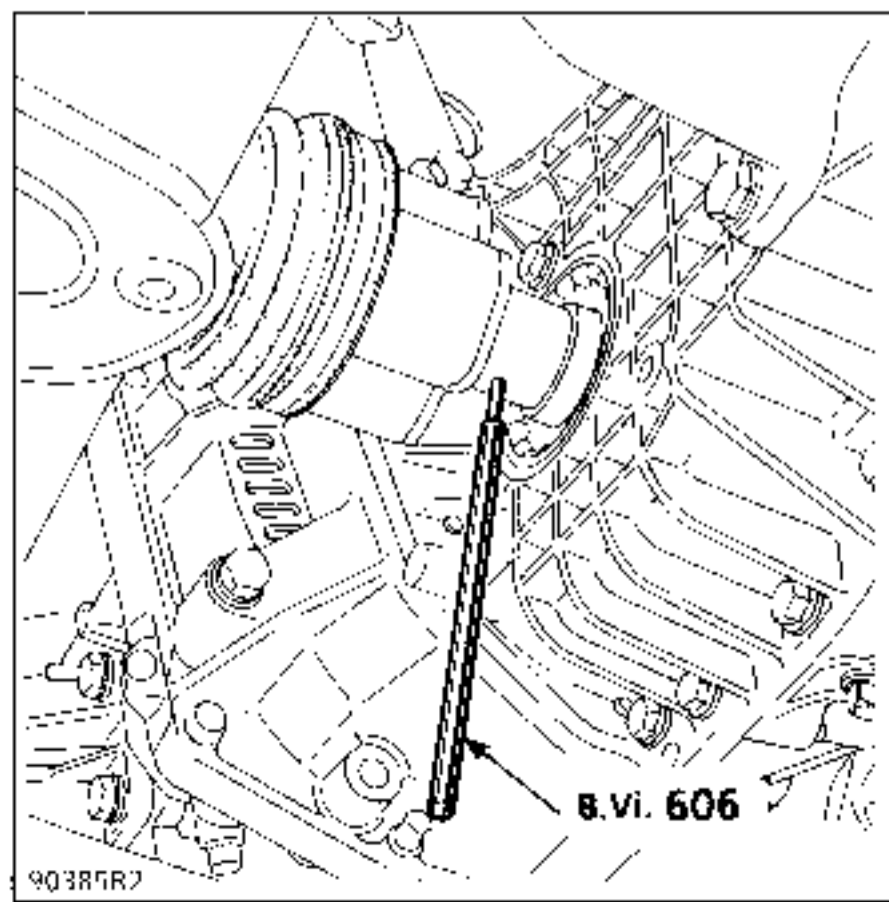

Remove one track rod end (tool **T.Av. 476**).

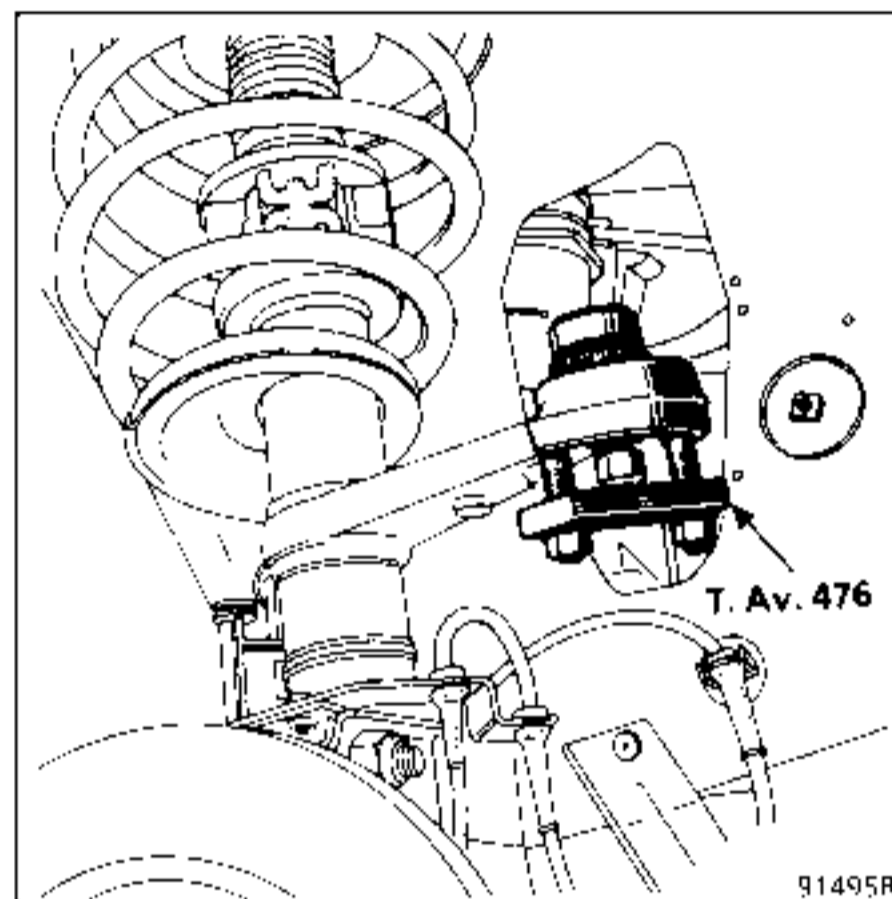

On the left and right hand sides, slacken the lower shock absorber base mounting bolts (2) and remove the upper mounting bolts (1).

NOTE : the bolts have a splined section and a mallet must be used to remove them.

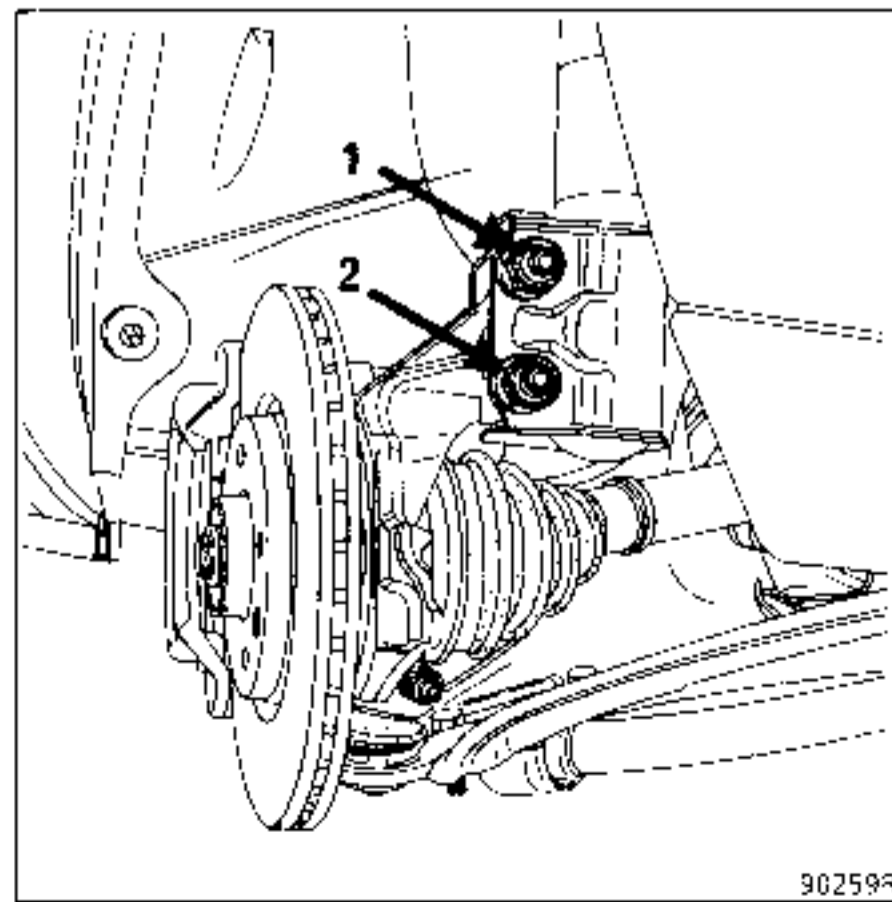

Tilt the stub axle carriers and release the driveshafts.

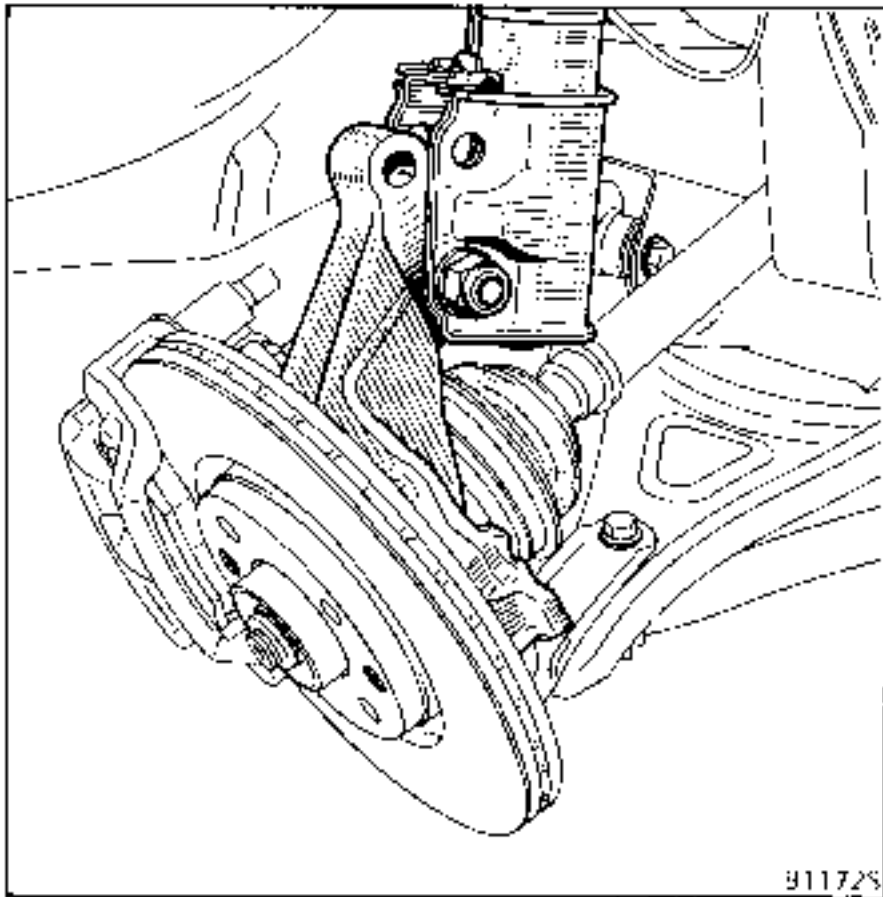

Apply adhesive tape or fit a protective cover (supplied with new driveshafts) to the differential output seal face.

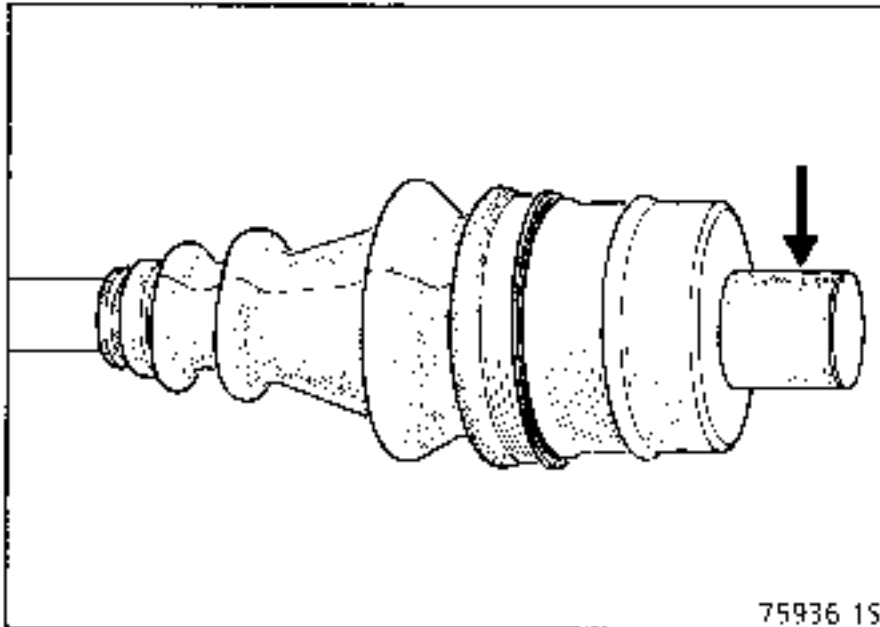

Remove:

- the turbo heat shield,
- the primary exhaust pipe flange,
- the two nuts at (A),
- the stud at (B).

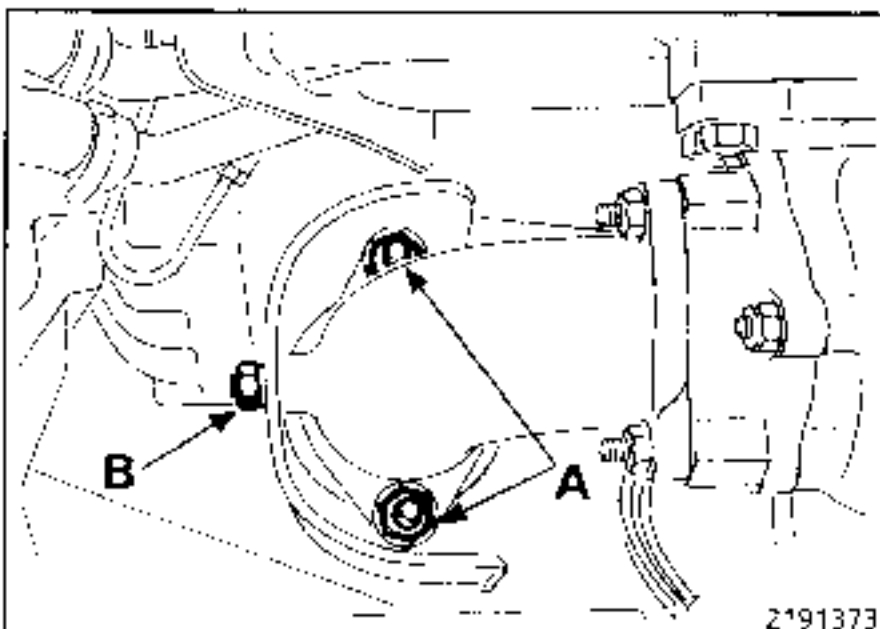

Separate the rigid coolant pipes and remove the clutch slave cylinder (do not disconnect the pipe) and attach it to the steering.

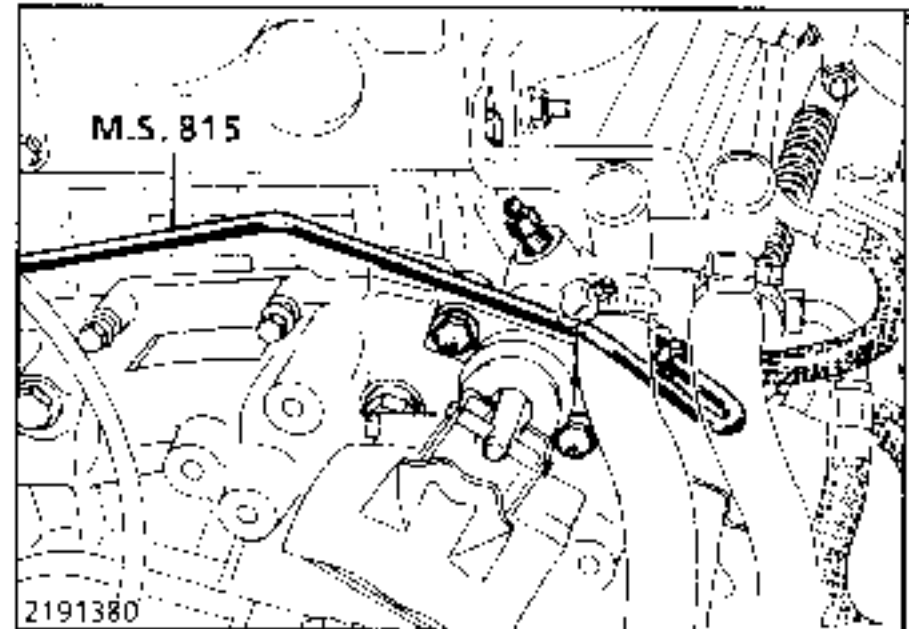

Remove:

- the A.E.I. sensor,
- the starter motor bolts,
- the upper bolts at the edge of the gearbox,
- the tie rod mounting bolt.

Disconnect:

- the speedo cable.

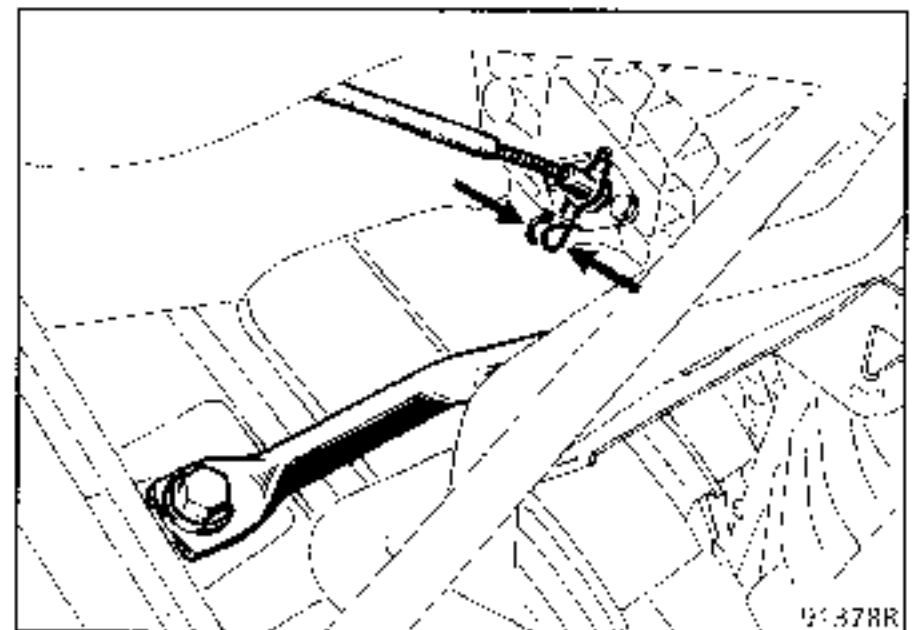

Under the vehicle, remove:

- the tie rod,
- the primary exhaust pipe,
- the gear controls:
 - at (A) the two ball joint cover bolts,
 - at (B) release the ball joint,
 - at (C) the reverse gear locking device.

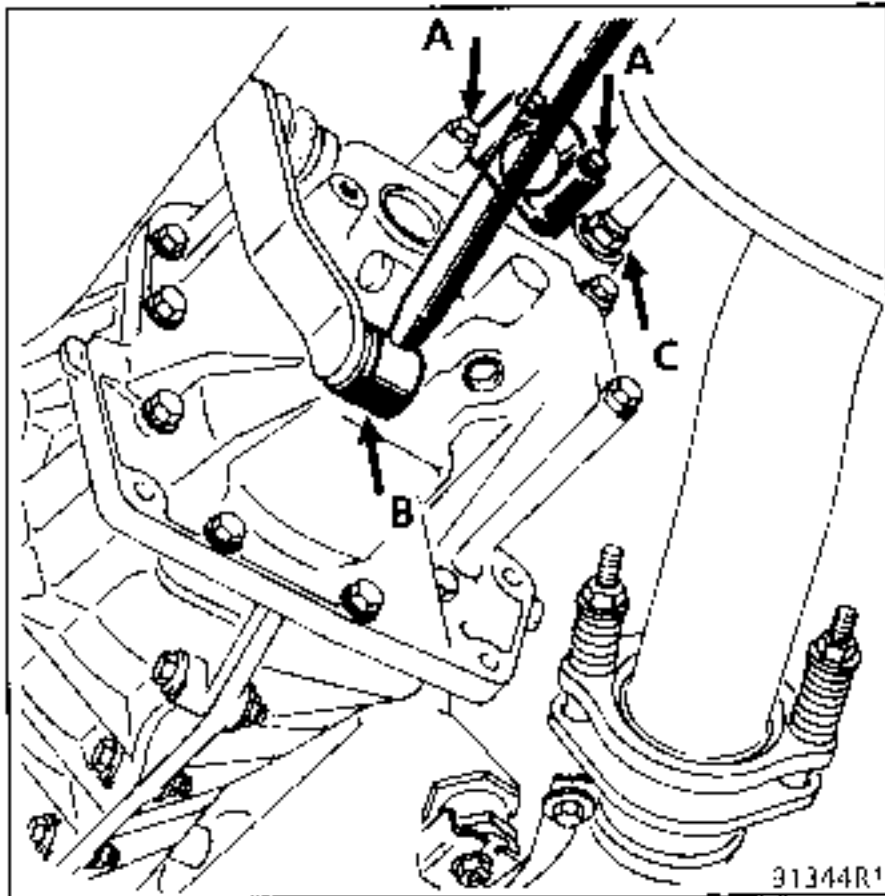

Disconnect:

- the reversing lights switch wires,
- the exhaust pipe flexible mountings.

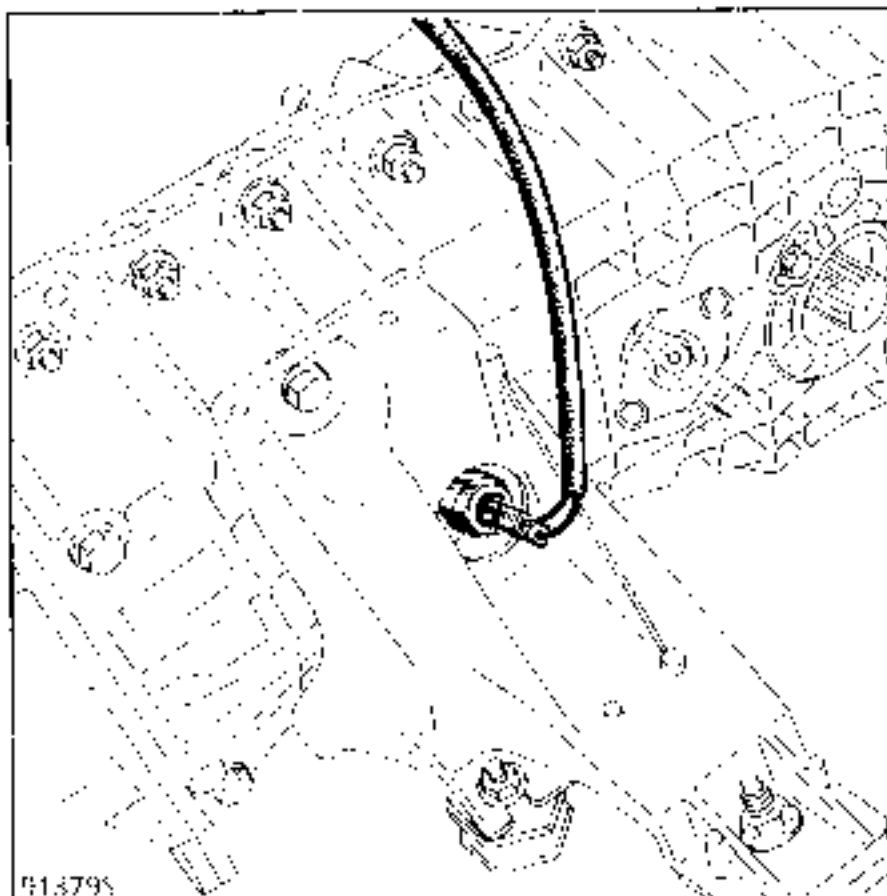

Position the component jack.

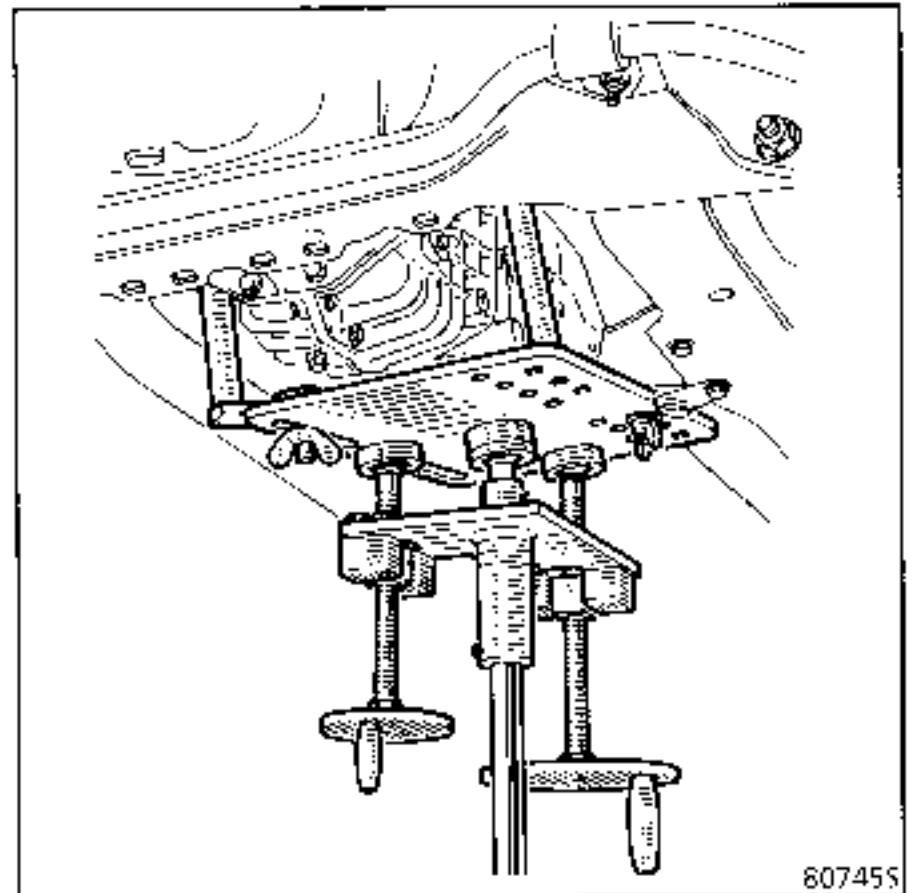

Remove the side mountings.

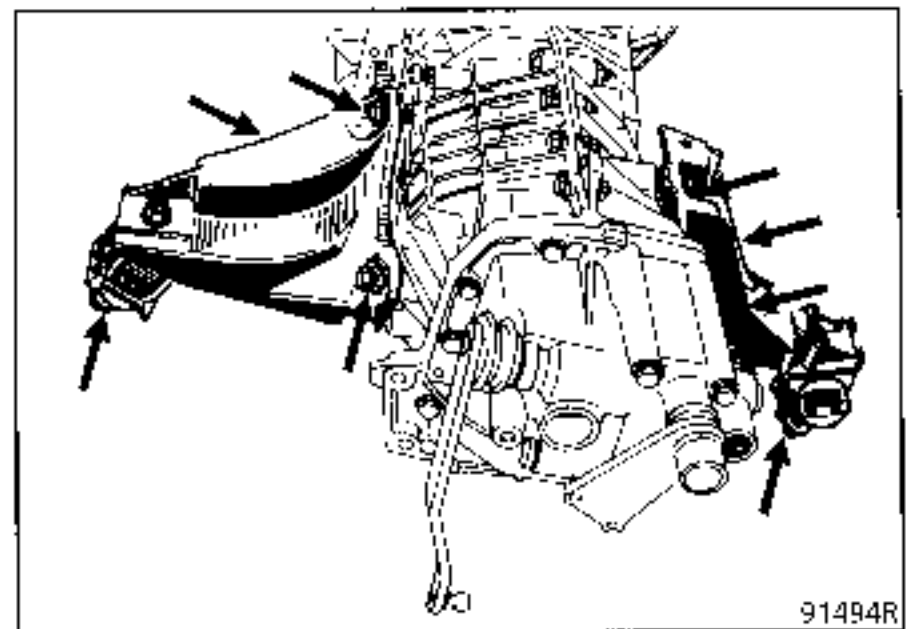

Pull the gearbox towards the rear of the vehicle taking care not to catch the gear controls.

REFITTING - Special notes

Before refitting the gearbox to the vehicle, check the centring dowels (A) and (B) are present on the clutch bellhousing.

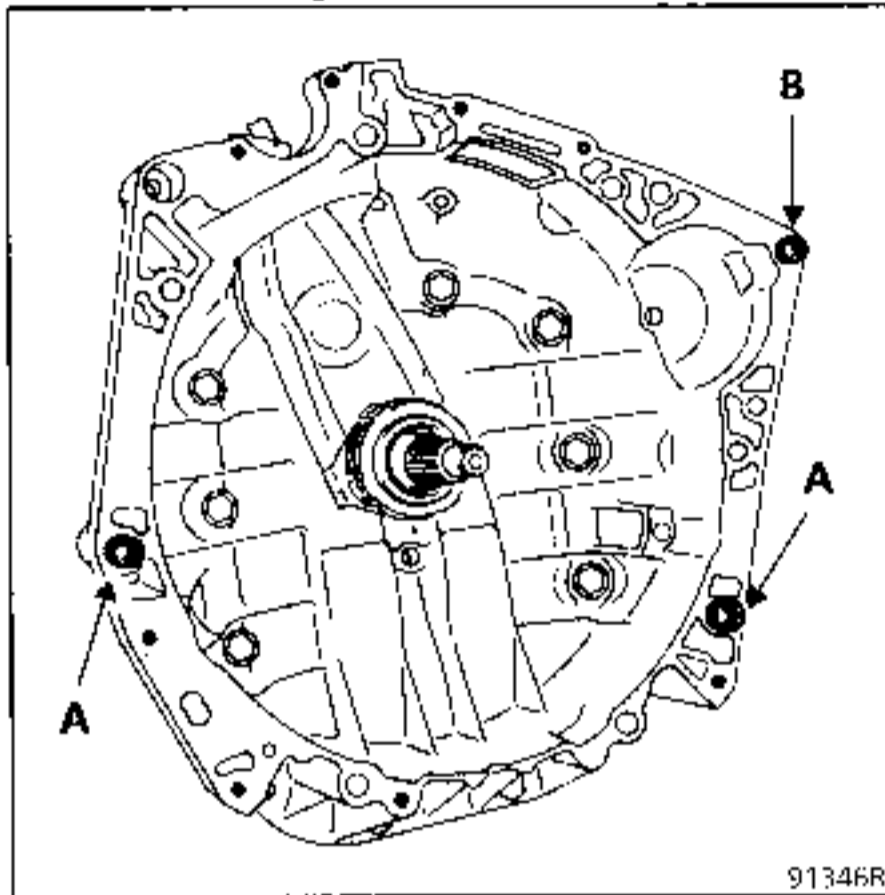

Coat the splines of the thrust pad bore, the clutch shaft and the sunwheels with **MOLYKOTE BR2**.

Assemble the engine and gearbox and refit the side mountings.

Ensure the rubber washer (R) is fitted which must be placed between the end of the sunwheel (P) and the base of the driveshaft yoke.

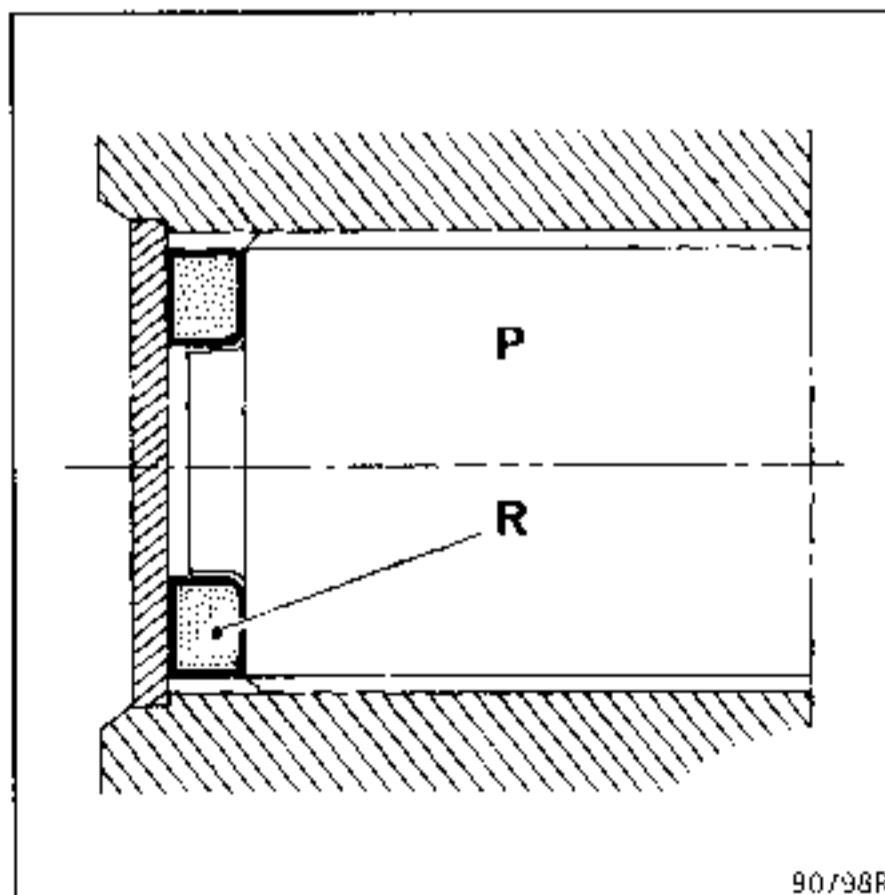

NOTE : ensure that there are no scratches or abnormal traces of wear on the lip seal bearing face on the driveshaft.

Position the driveshaft in relation to the sunwheel, pivot the stub axle carrier, engaging the driveshaft into the sunwheel using the angled pin B.Vi. 606 to align the holes.

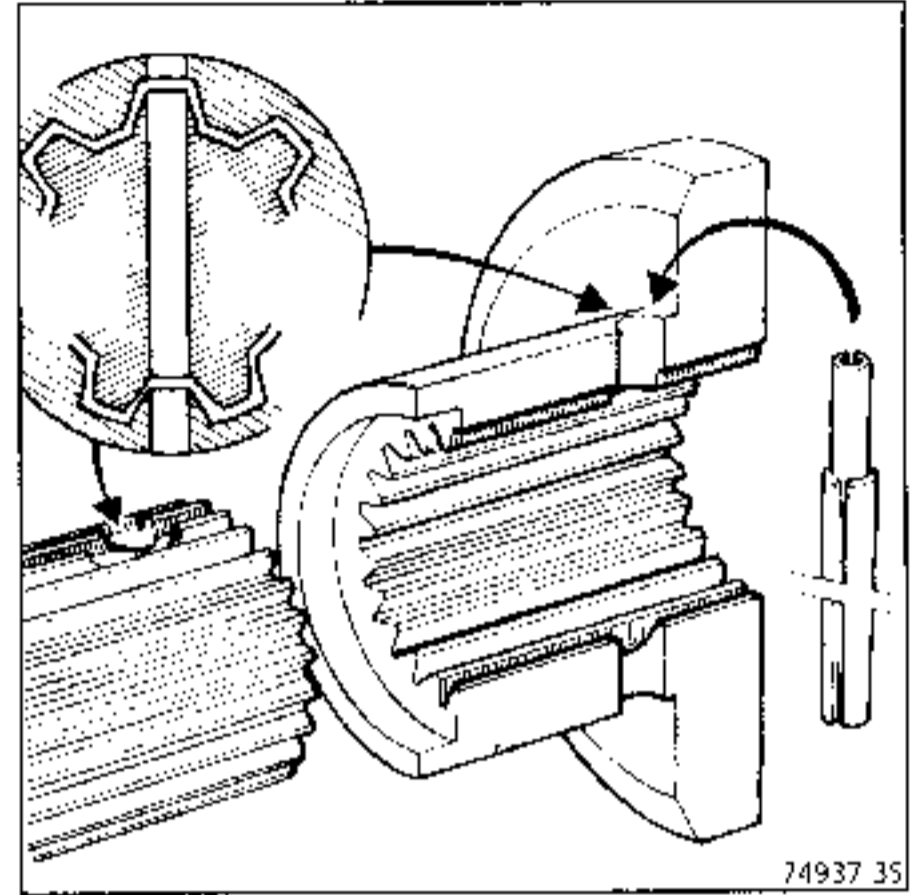

Fit new driveshaft roll pins and seal the ends (**RHODORSEAL 5661**).



Check the heat shields are correctly refitted.

Tighten all nuts and bolts to the correct torque.

Fill the gearbox with oil.

Additional information to the method given for 4 x 2 vehicles (UN1)

TIGHTENING TORQUES (in daN.m)		
Gearbox output flange bolt	2.5	
Intermediate bearing mounting bolt	2.5	

REMOVAL

Depolluted vehicles - Special notes

Disconnect the connector (2) for the oxygen sensor (1).

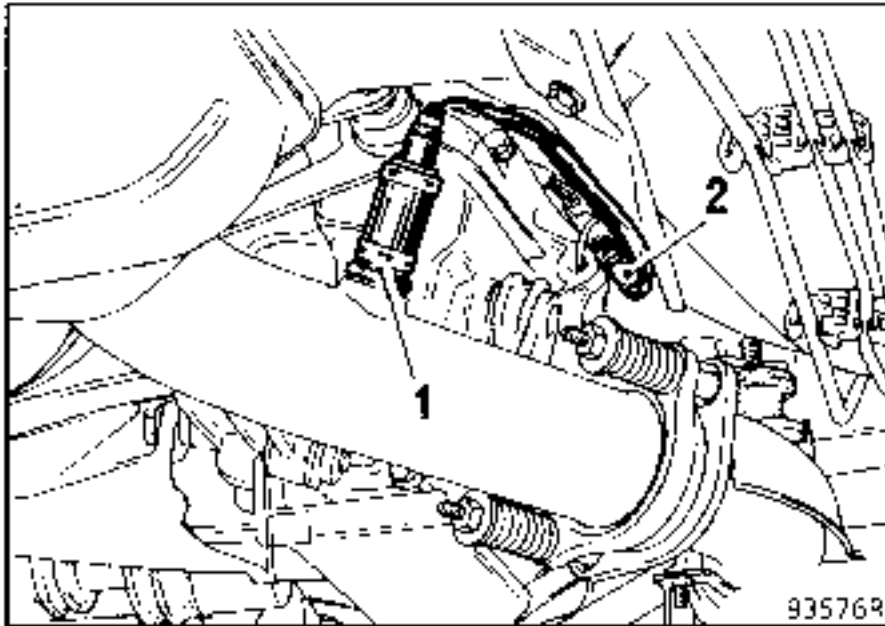

Remove the catalytic converter.

NOTE : the catalytic converter must not be subjected to any mechanical impact as it could be destroyed if the impact is repeated.

Remove the mounting bolts for the prop shaft intermediate bearing.

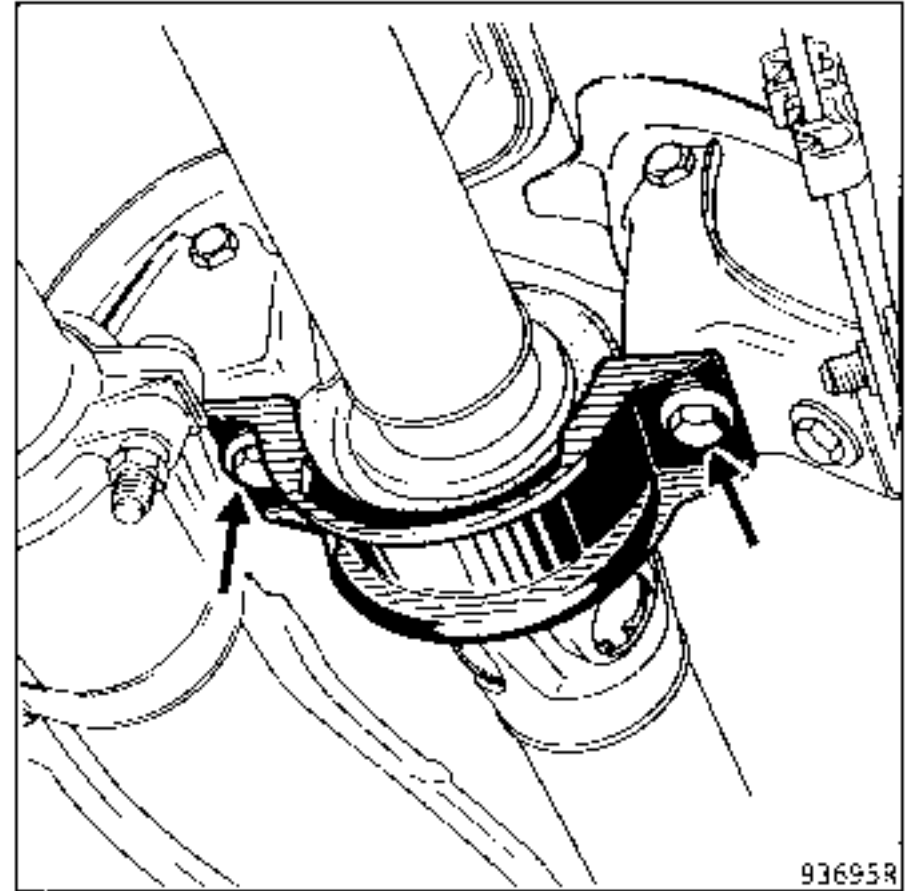

Release the driveshaft from the gearbox output flange.

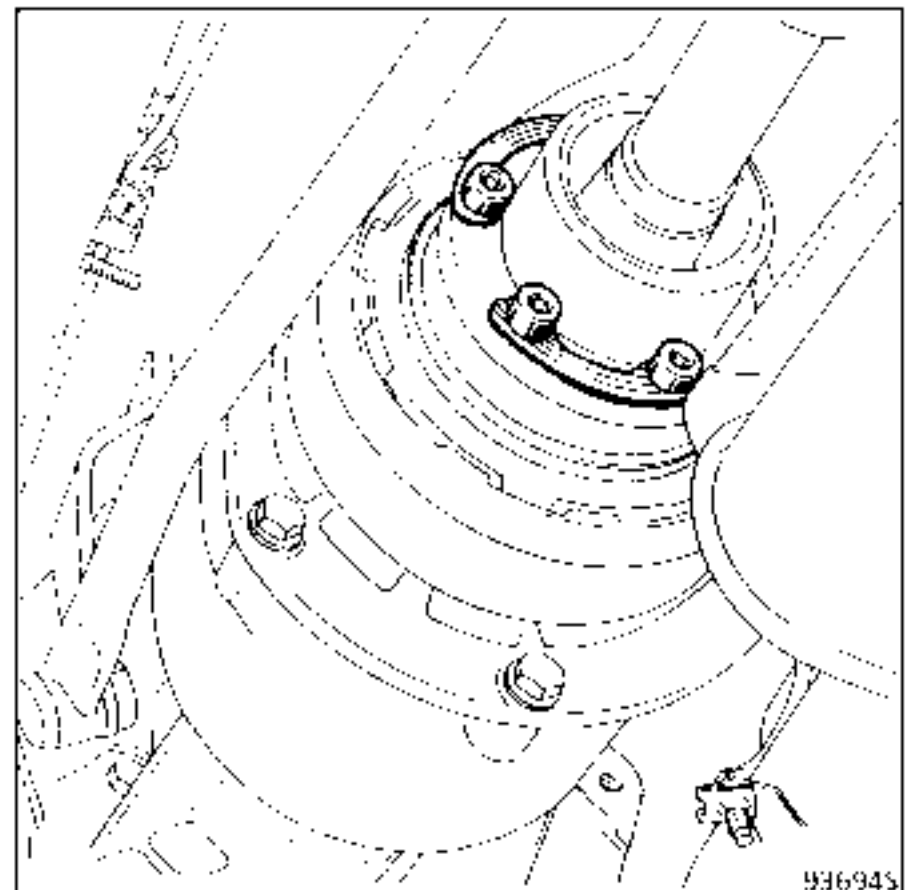

Protect the gaiter on the LOBRO joint.

Disconnect:

- the gear controls:
 - at (A) the two ball joint cover bolts,
 - at (B) release the ball joint,
 - at (C) the reverse gear locking device using a standard wrench modified in the workshop.

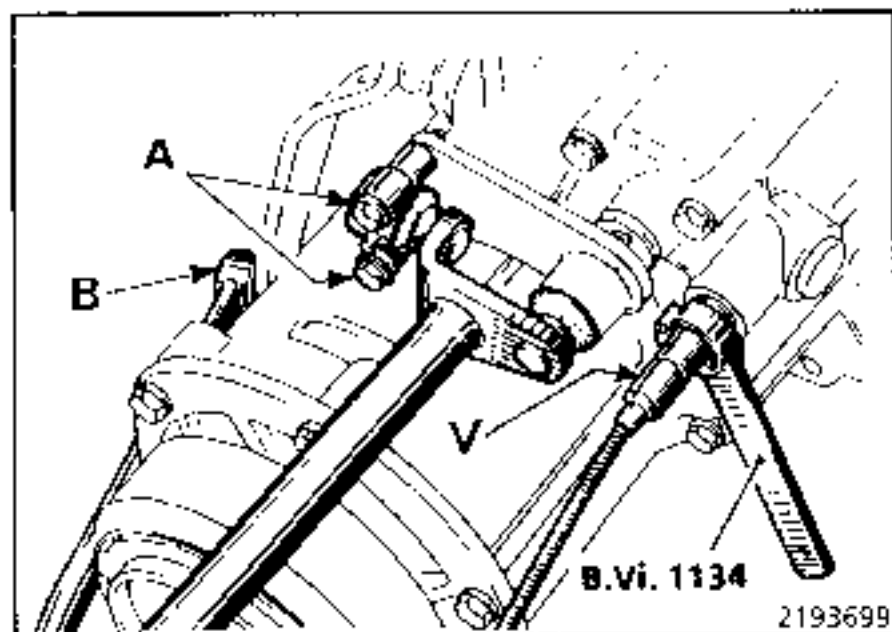

- the connectors for the reversing lights and first gear switches.

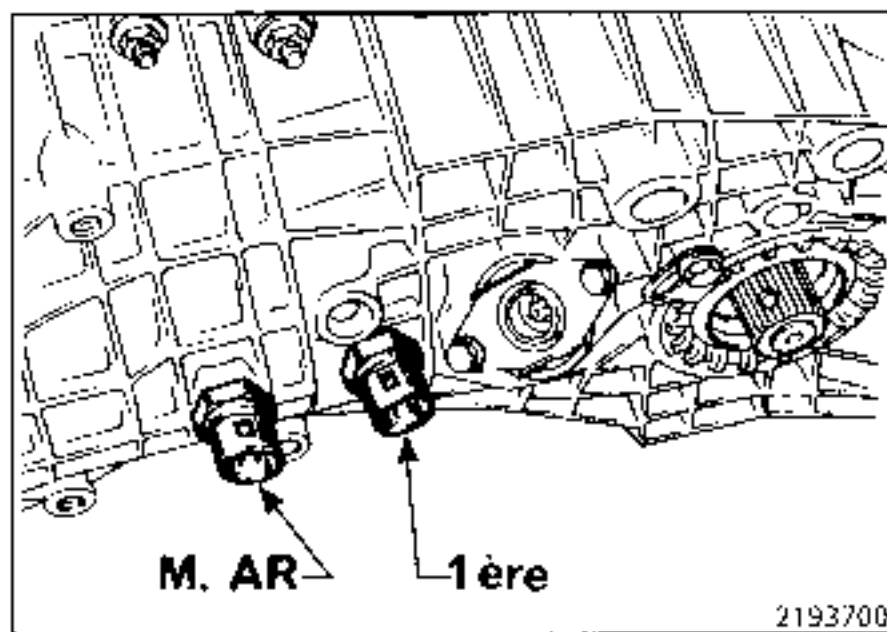

REFITTING - Special notes

Systematically renew the driveshaft mounting bolts and the flange seal which is bonded with grease before the driveshafts are fitted (depending on assembly).

Depolluted vehicles

Reconnect the oxygen sensor connector and ensure it is properly connected.

The exhaust pipe must be sealed correctly up to the catalytic converter.

The exhaust flange has spacers (1) which determine the spring tension.

Tighten until the springs touch the spacers.

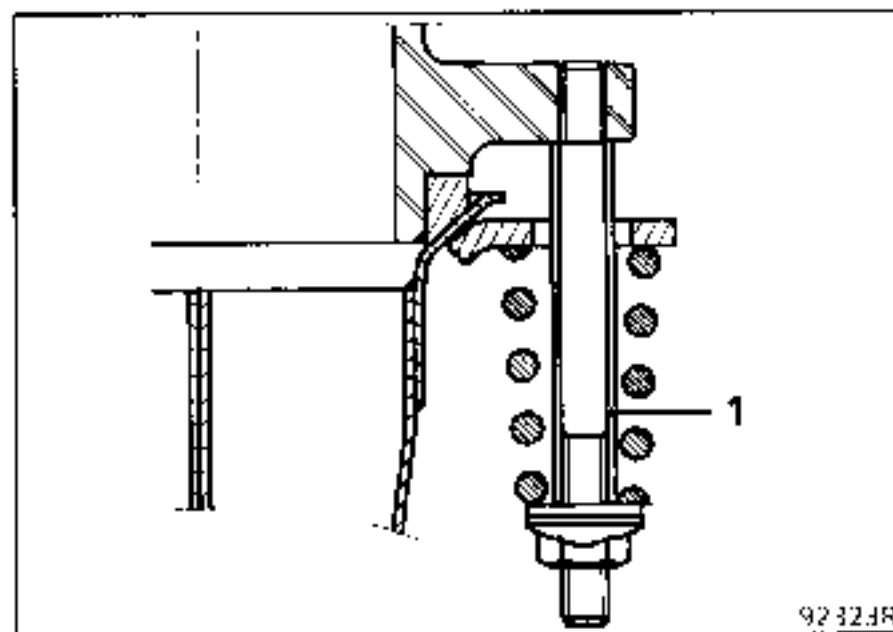

Position the clips so that their tightening surface bears equally on the two pipes to be connected.

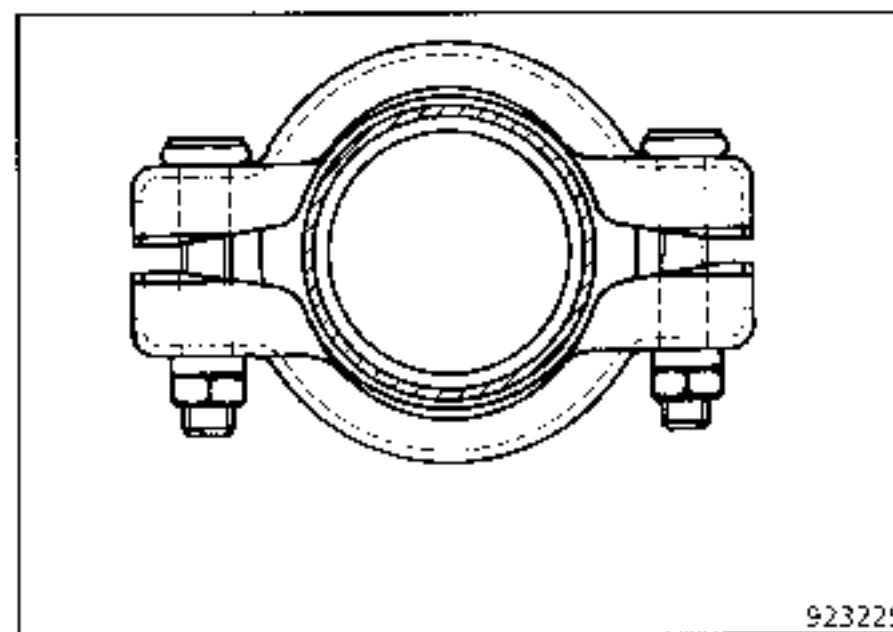

Observe the correct tightening torque.

SPECIAL TOOLING REQUIRED

B.Vi. 28-01	Extractor tool
B.Vi. 31-01	Set of punches for removing and fitting roll pins of diameter 5 mm
B.Vi. 1007	Jaws for B.Vi. 28-01

TIGHTENING TORQUES (in daN.m)



Primary shaft nut	13.5
Secondary shaft bolt	7

REMOVAL

Put the vehicle on a 2 post lift.

Remove the front left hand wheel.

Remove the wheel arch protector.

Remove the sub-frame side member tie rod.

Remove the engine undertray.

Drain the gearbox.

The rear housing must be removed along the horizontal centre line of the gearbox as it bears a lubricating duct (A) which goes into the primary shaft.

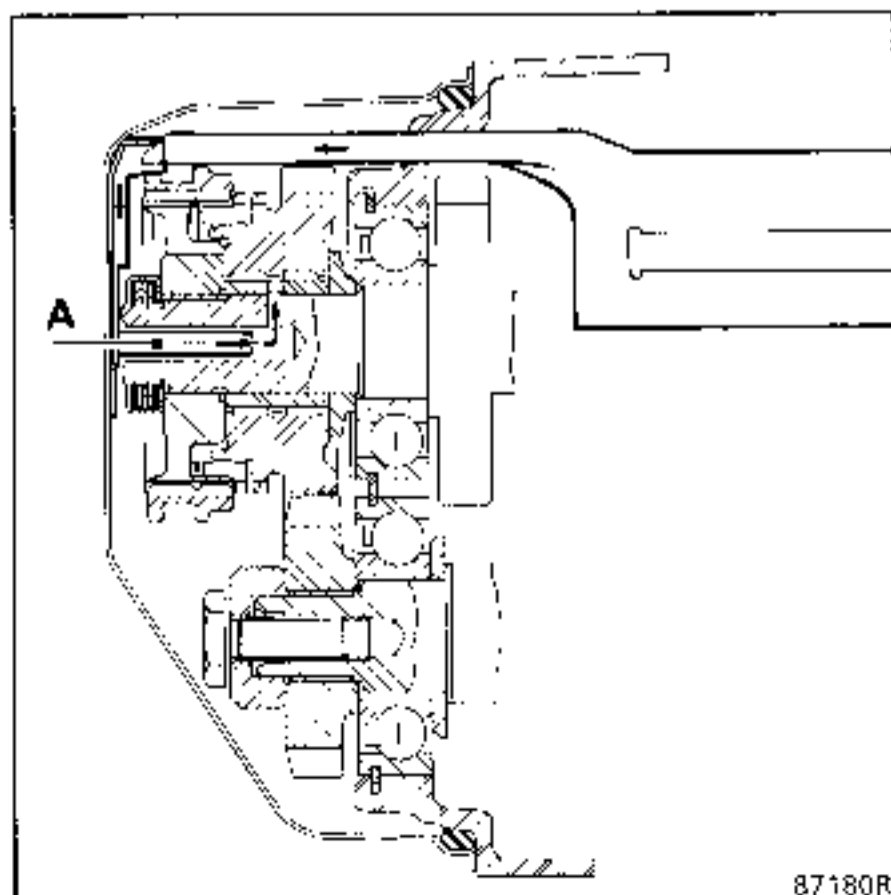

87180R

CONSUMABLES

LOCTITE FRENBLOC :

Primary shaft nut
Secondary shaft bolt
5th fixed gear
5th gear hub

Fit:

- a drainage tray under the rear housing and remove the housing,
- a wooden block between the 5th gear fork and drive pinion as a support then remove the roll pin from the fork using tool B.Vi. 31-01.

SPECIAL NOTE

Do not pull outwards on the 5th gear fork shaft as the locking plunger will fall into the gearbox. Engage a gear for safety (3rd or 4th).

Removing the roll pin may be made easier by slightly bending punch B.Vi. 31-01 to avoid having to lift the gearbox.

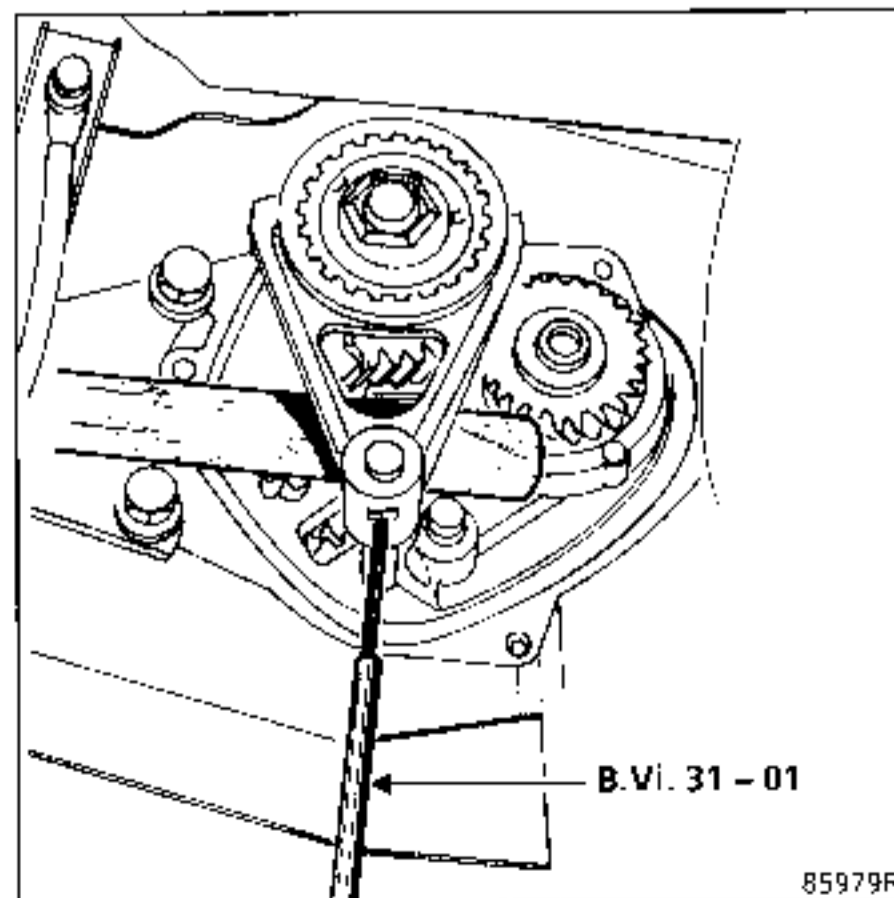

85979R

Lock the gearbox by selecting 1st at the lever and 5th in the gearbox by sliding the 5th gear fork inwards on its shaft.

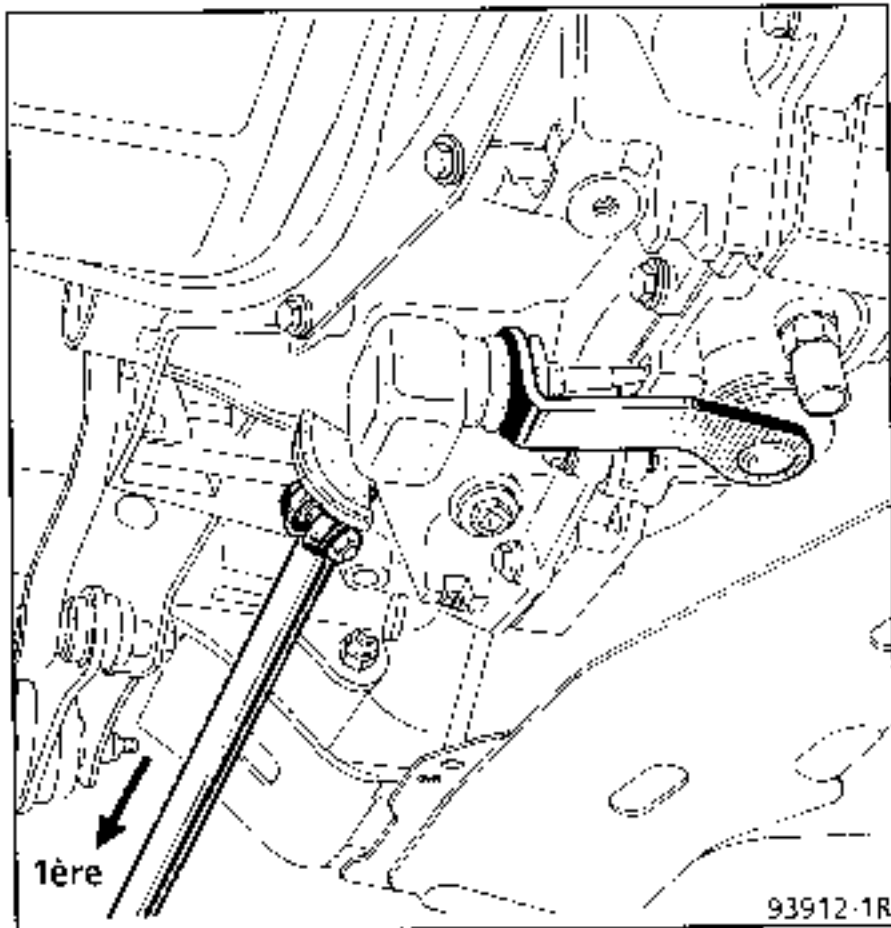

Release and remove the primary shaft nut and the secondary shaft bolt (65).

Return the gearbox to neutral.

On the primary shaft

Remove the 5th gear fork and the sliding gear, taking care not to pull the 5th gear shaft outwards.

Remove the synchro hub using tool B.Vi. 1170.

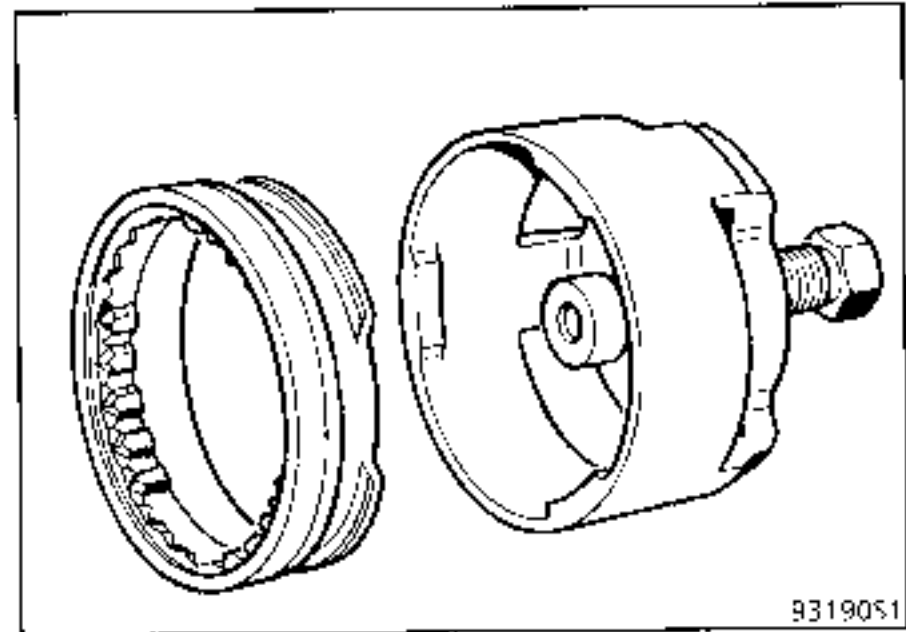

Fit the sliding gear from tool B.Vi. 1170 as if to engage 5th gear and turn it so the splines on the sliding gear are opposite those on the hub.

Remove the 5th gear assembly.

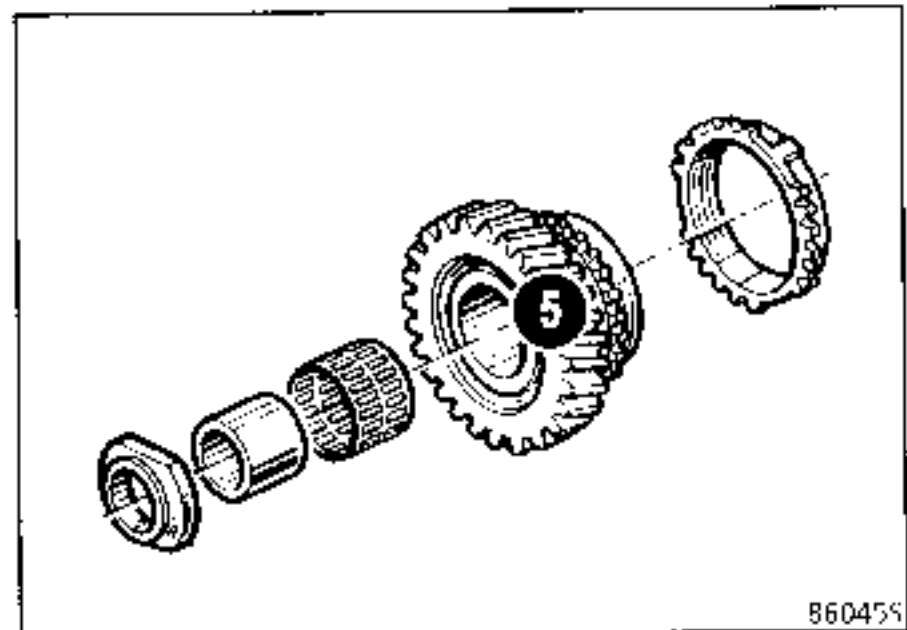

On the secondary shaft

Remove the shouldered washer (64).

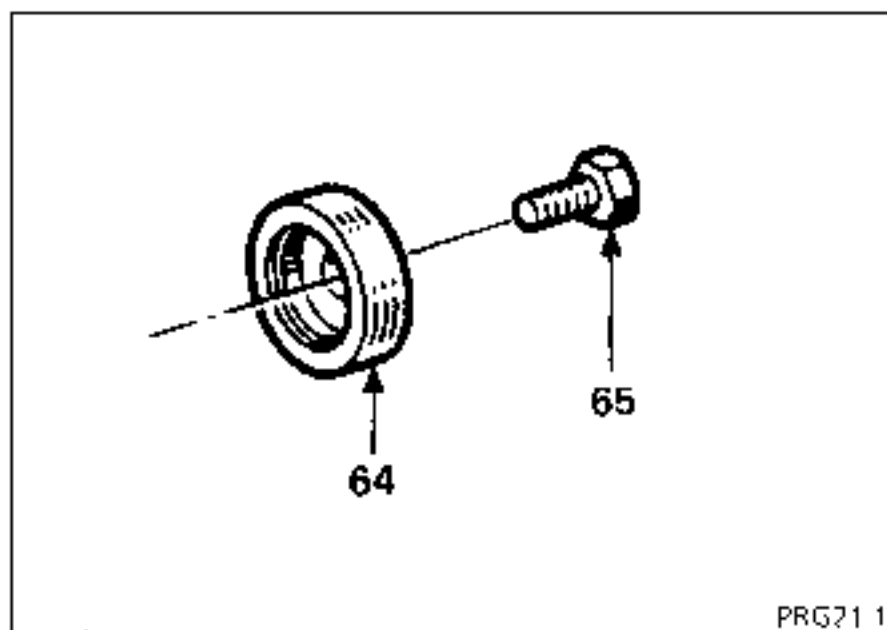

Remove the fixed gear using tool B.Vi. 28-01 with jaws B.Vi. 1007.

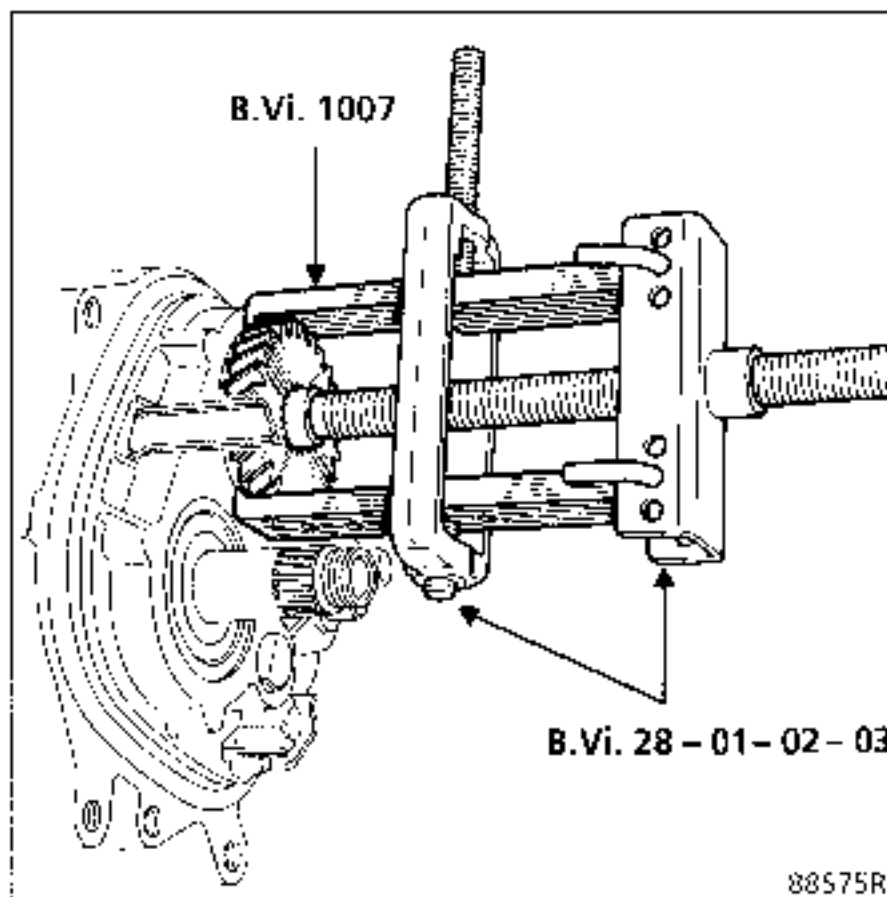
**REFITTING****On the secondary shaft**

Apply 3 drops of **LOCTITE FRENBLOC** to the splines of the fixed gear.

Fit the shouldered washer (64).

On the primary shaft

Refit the parts in the order (21) (shoulder facing ring (22), (23), (24) and (8)).

Fit the fork to the sliding gear (26) fitted with (25).

Apply 3 drops of **LOCTITE FRENBLOC** to the hub and refit the hub sliding gear and fork assembly.

Place the bosses on the synchro ring in the notches on the hub.

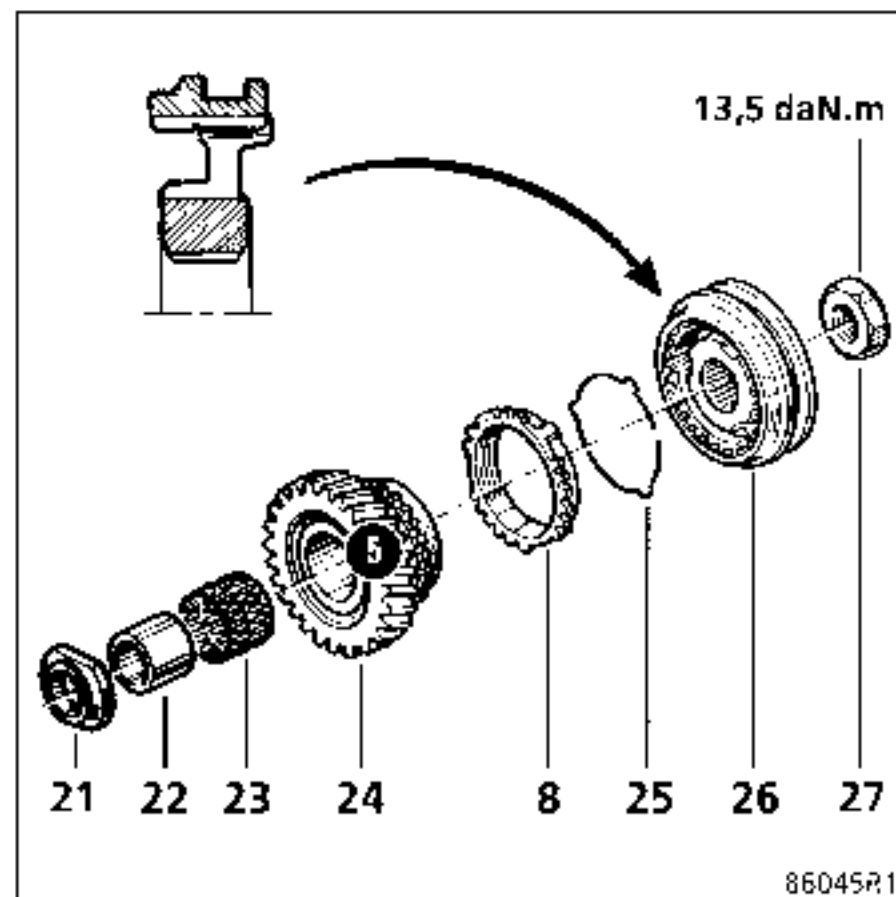

Select 1st at the lever and 5th in the gearbox by sliding the 5th gear fork on its shaft.

Apply 3 drops of **LOCTITE FRENBLOC** :

- to the nut (27) on the primary shaft and torque tighten to **13.5 daN.m**,
- to the bolt (65) and torque tighten to **6.3 daN.m** to press the fixed gear into position.

MANUAL GEARBOX

5th speed linkage on vehicle

Place a wooden block between the 5th gear fork and the drive pinion to act as a support and fit a new roll pin in the 5th gear fork using tool **B.Vi. 31-01** ensuring the pin is fitted the correct way round - the slot should be facing the rear housing.

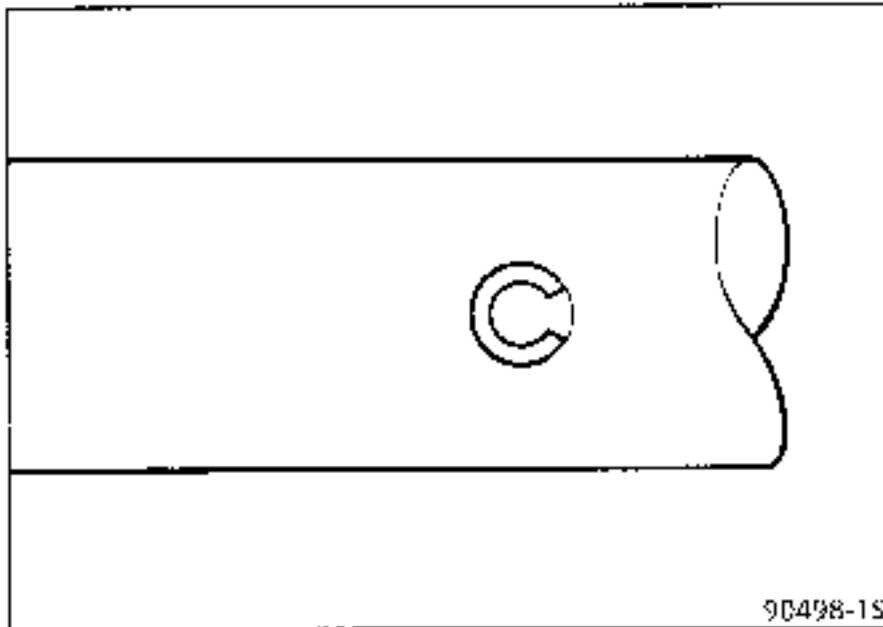

90498-15

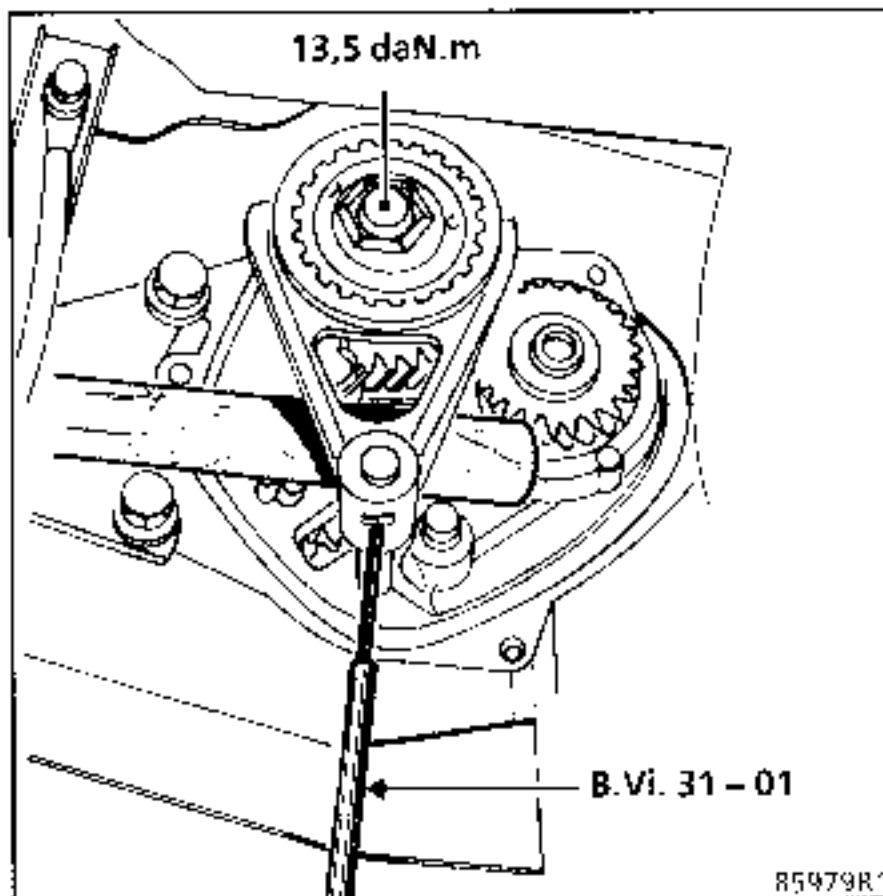

85979R

Fit a new O ring to seal the rear housing.

Return the gearbox to neutral and check that all gears can be selected.

If there is a fault, check that reverse gear is not engaged.

Fit the rear housing, fitting duct (A) into the primary shaft.

Torque tighten the mounting bolts to **2.4 daN.m**.

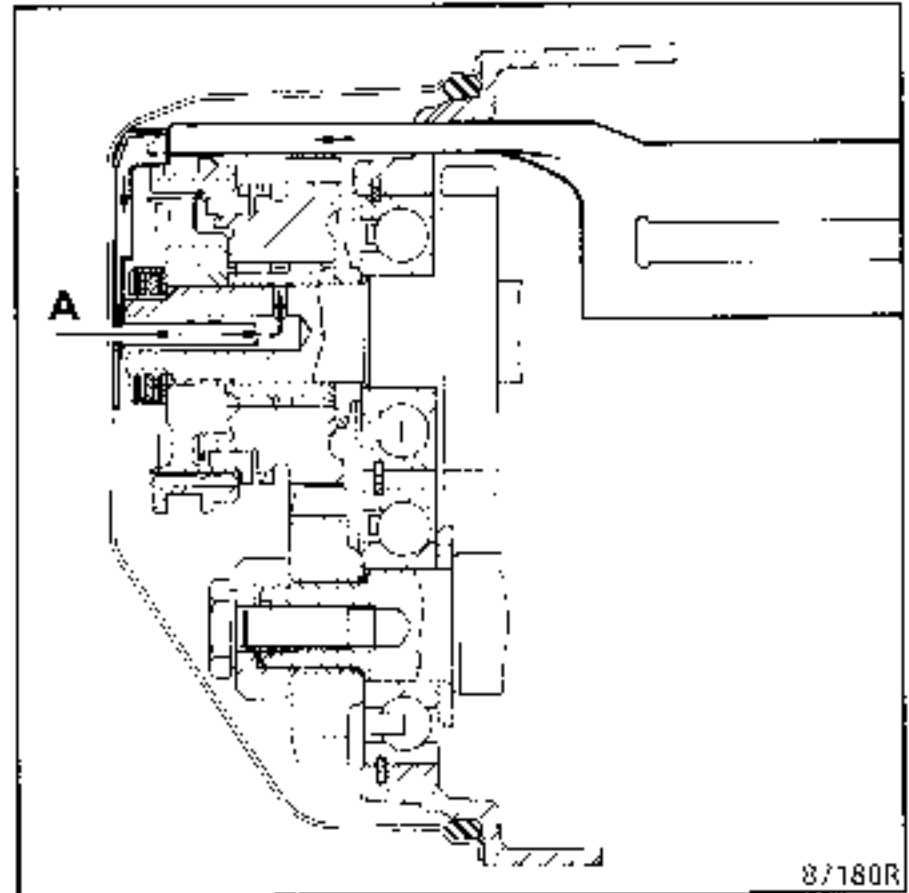

8/180R

Fill the gearbox with oil.

Check the rear housing is sealed when the engine is running.

REMOVAL - REFITTING

SPECIAL TOOLING REQUIRED

B.Vi. 31-01	Set of punches for roll pins
B.Vi. 1170	5th gear hub extractor

TIGHTENING TORQUES (in daN.m)



Primary shaft nut	13
Secondary shaft nut	20
Rear housing bolt	1.6 to 2
Output flange bolt	2.5

REMOVAL

Drain the gearbox.

Remove:

- the catalytic converter (if necessary),
- the selector controls:
 - at (A) the two mounting bolts,
 - at (B) release the ball joint,
- the reverse gear locking device (V) (use a wrench modified locally in the workshop),
- the 5th gear locking ball.

Disconnect:

- the differential lock control pipes (T),
- the speedo cable after removing the plastic roll pin,
- the differential lock switch connector.

Remove the prop shaft.

Select 3rd gear to lock the 5th gear fork shaft.

NOTE : do not remove the 5th gear fork shaft (A), as the locking ball (B) may fall into the gearbox.

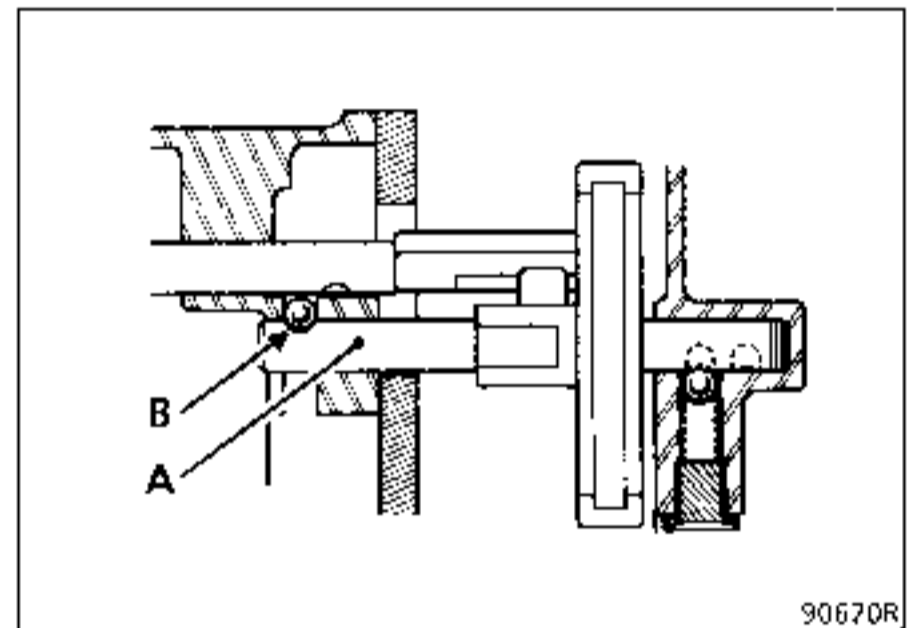

90670R

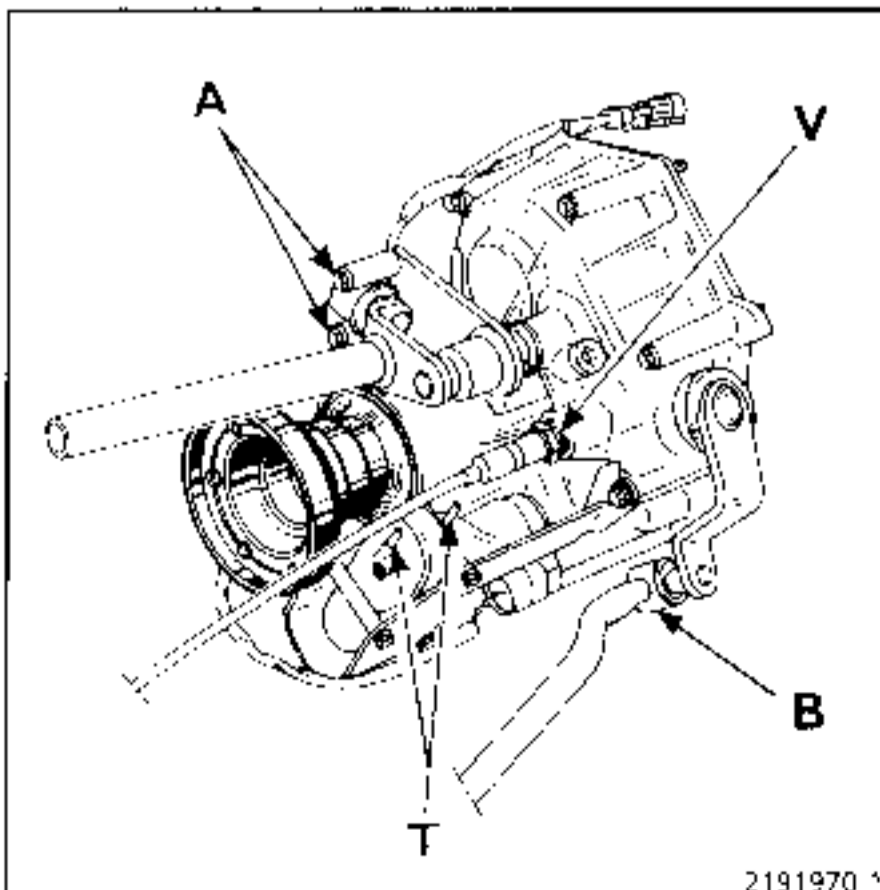

2191970 1

REMOVAL - REFITTING (cont)

Remove the rear housing bolts and remove the housing.

Remove the circlip.

Use an extractor (eg- FACOM U32-120) or similar to remove the carrier (3).

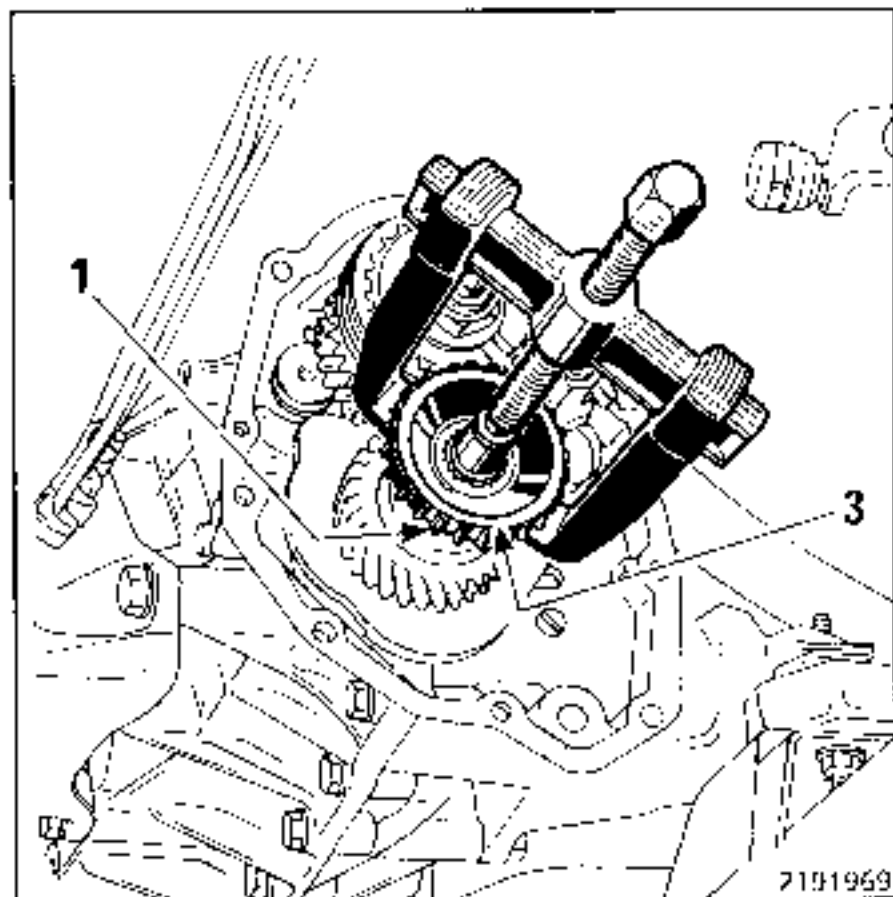

Return the gearbox to neutral, then select 5th gear and 2nd gear and slacken nut (1) using a 36 mm long socket (eg- FACOM K36LA).

Slacken the primary shaft nut.

Return the gearbox to neutral then select 3rd gear again.

Remove the roll pin from the 5th gear fork using tool B.Vi. 31-01, then remove the 5th gear sliding gear - fork assembly.

Remove the 5th gear hub using tool B.Vi. 1170.

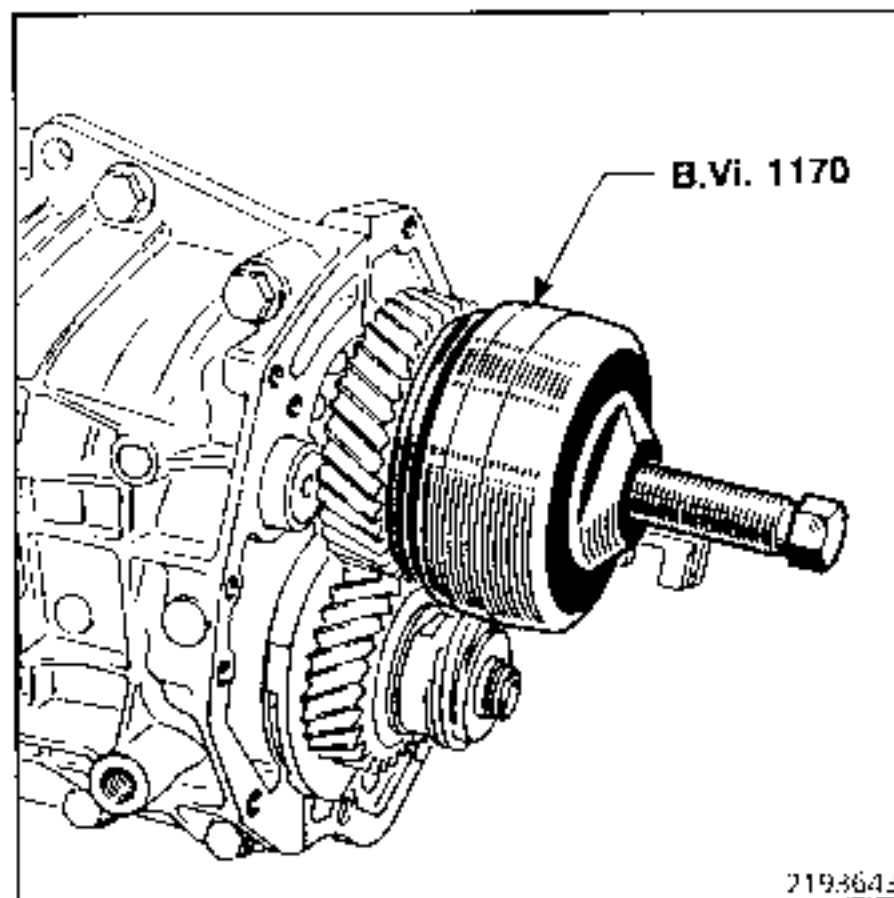

Fit the sliding gear from tool B.Vi. 1170 as if to engage 5th gear and turn it so the splines on the sliding gear are opposite those on the hub.

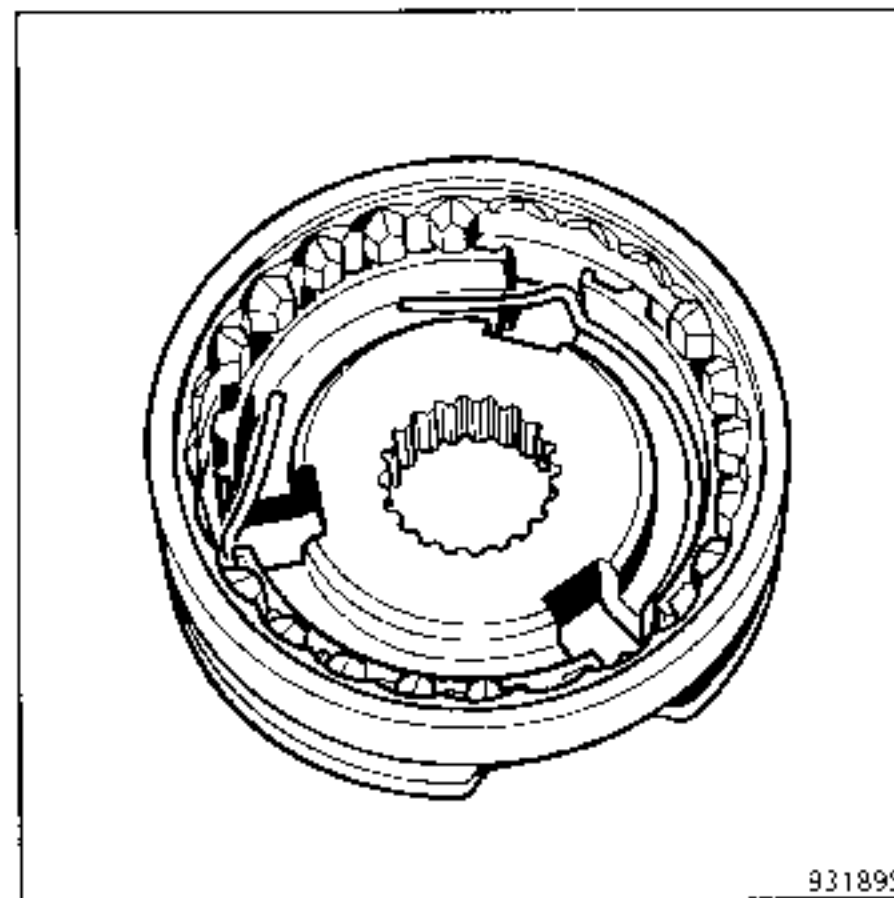

Fit the bell shaped part of the tool on the sliding gear, turn it as far as it will go then remove the hub.

On the secondary shaft

Fit the jaws of the extractor under the spacer plate and remove the 5th gear fixed gear with the plate.

REFITTING - Special notes

Ensure the fixed gear is fitted the correct way round and bond it using **LOCTITE FRENBLOC**.

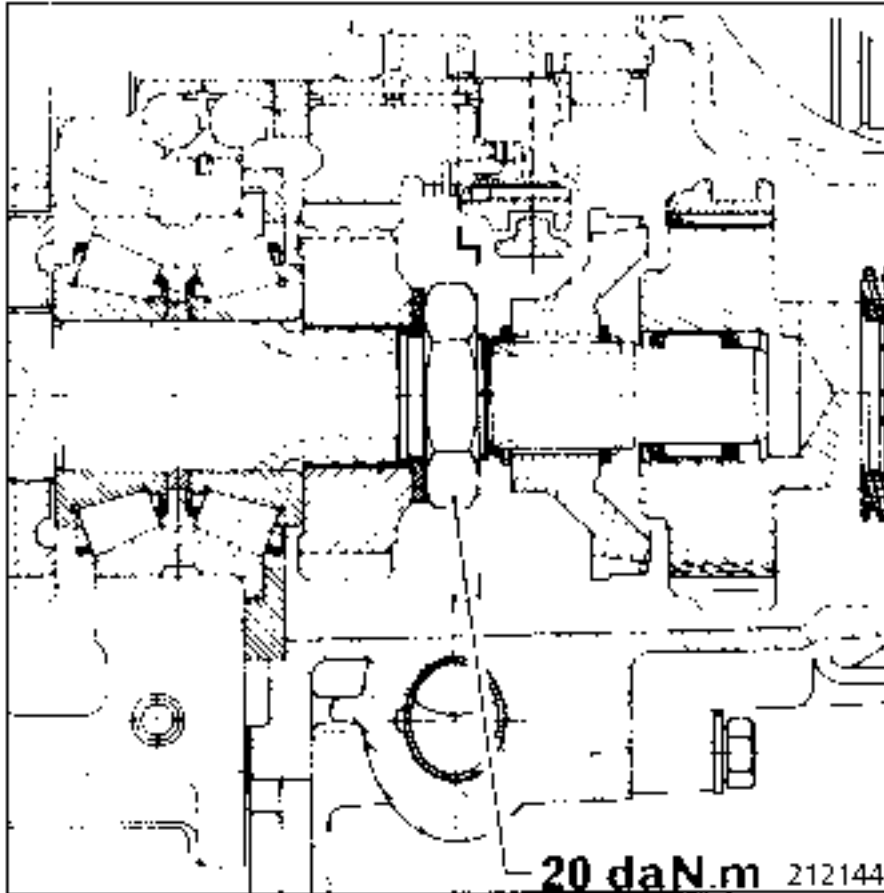
**On the primary shaft**

Bond the hub with **LOCTITE FRENBLOC** and ensure the assembly is fitted the correct way round.

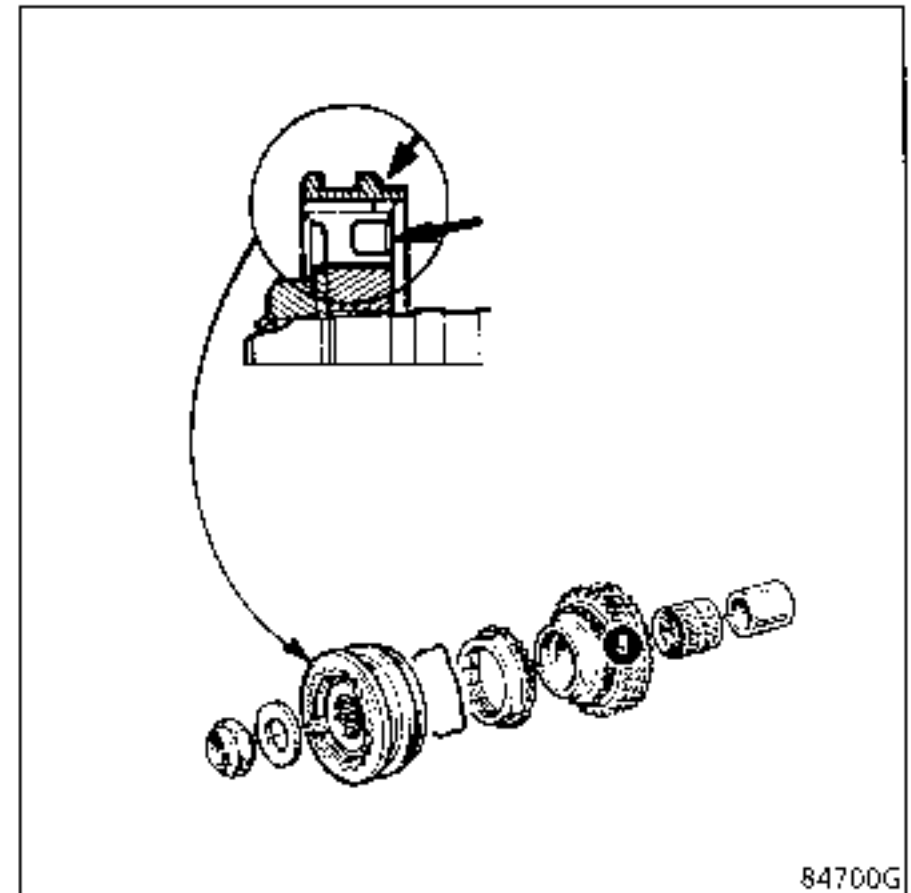

Place the bosses on the synchro ring in the notches on the hub.

Fit:

- the 5th gear synchro, hub and sliding gear and fork assembly,
- the spring washers.

Apply 3 drops of **LOCTITE FRENBLOC** to the threads of the new nuts and tighten them to the correct torque and lock the primary shaft nut.

REFITTING (cont)

Fit the roll pins to the fork using **B.Vi. 31-01**, the slot in the pin should be parallel to the shaft.

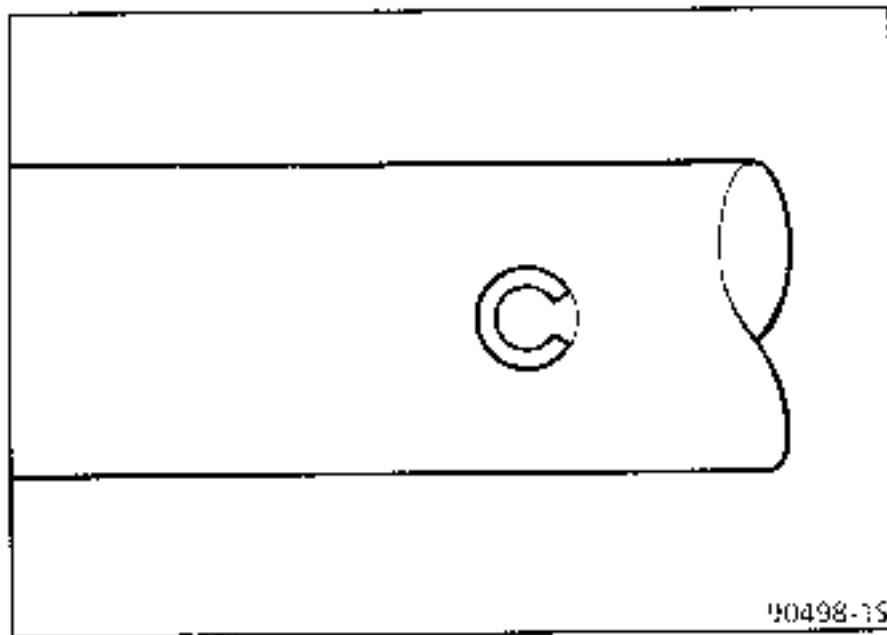

Fit the circlip.

Apply 3 drops of **LOCTITE FRENBLOC** to the carrier (3) and force fit it into position using a tube and mallet.

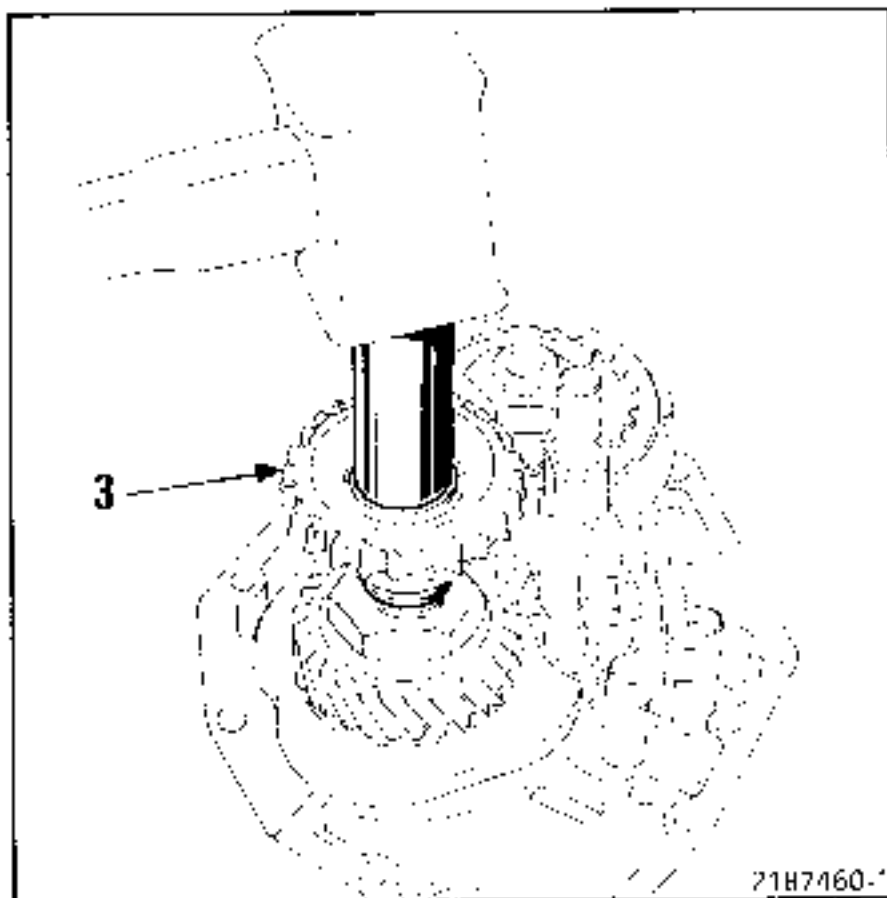

Wipe off all traces of **LOCTITE** from the output shaft bearing seat.

Fit:

- the second circlip,
- the cover seal (dry).

Select 3rd gear and fit the housing, positioning the selector finger in the 3rd gear fork shaft dog clutch.

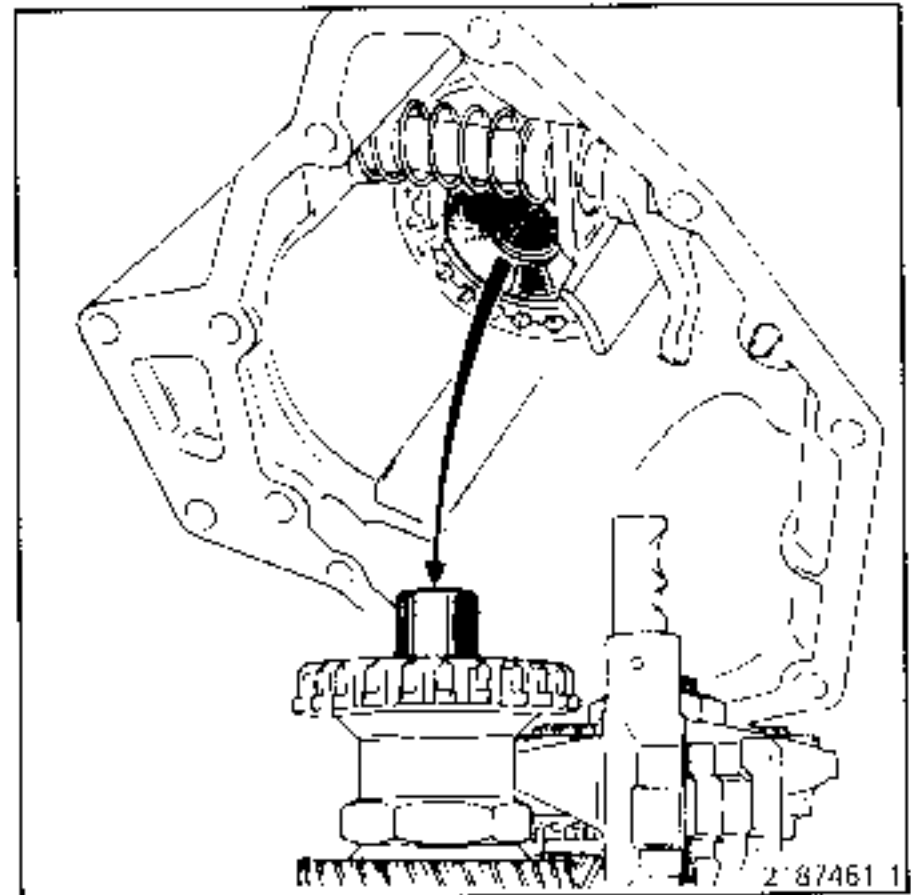

Position the spacer plate so that it fits in its seating in the rear housing and close the rear housing.



Tighten the bolts to the correct torque.

Refit the 5th gear locking ball, coat the plug thread with **RHODORSEAL 5661**.

De-select 3rd gear.

Check that all the gears can be selected.

Reconnect all the controls.

Ensure that the differential lock pneumatic pipes are correctly connected:

- the red pipe must be connected to the side marked (red label) on the vacuum capsule.

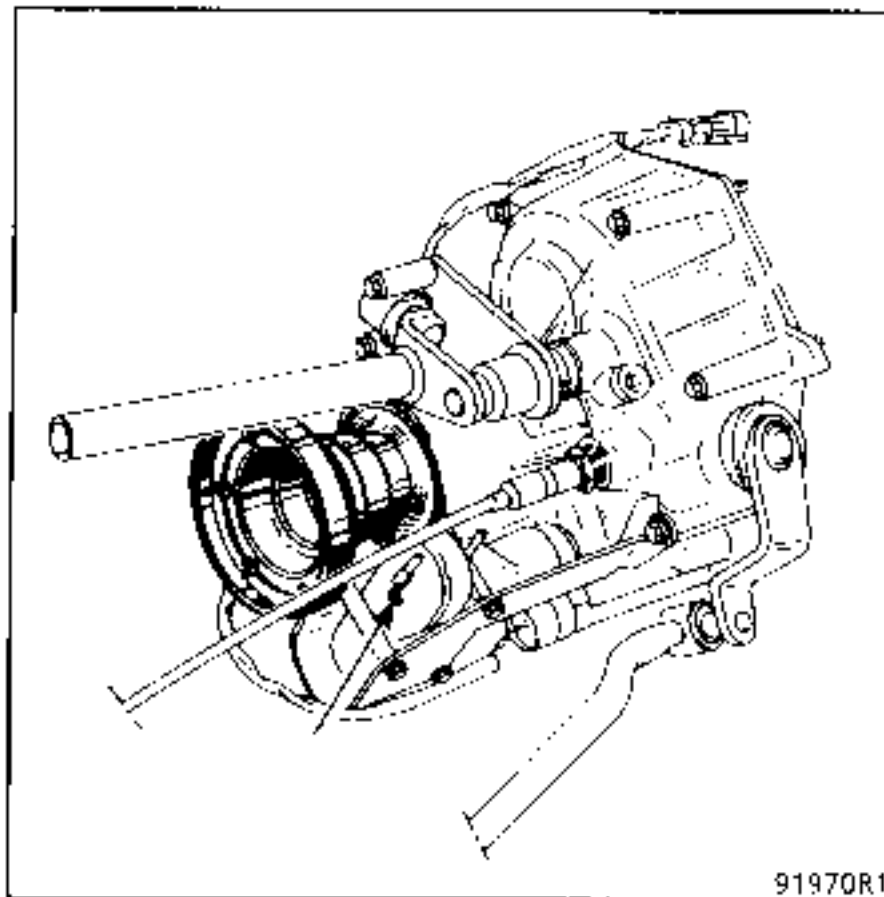

Refit the prop shaft.

Fill the gearbox with oil.

REMOVAL - REFITTING

SPECIAL TOOLING REQUIRED

B.Vi	28-01	Extractor tool (UN gearbox)
Rou.	15-01	Shaft protector end piece
B.Vi.	1007	Jaws for B.Vi. 28-01

TIGHTENING TORQUES (in daN.m)



Primary shaft nut	13.5
Secondary shaft nut	20
Rear housing bolt	2.5

REMOVAL

Drain the gearbox.

Remove:

- the gear selector controls:
 - at (A) the two mounting bolts,
 - at (B) release the ball joint,
 - at (C) the reverse gear locking device.

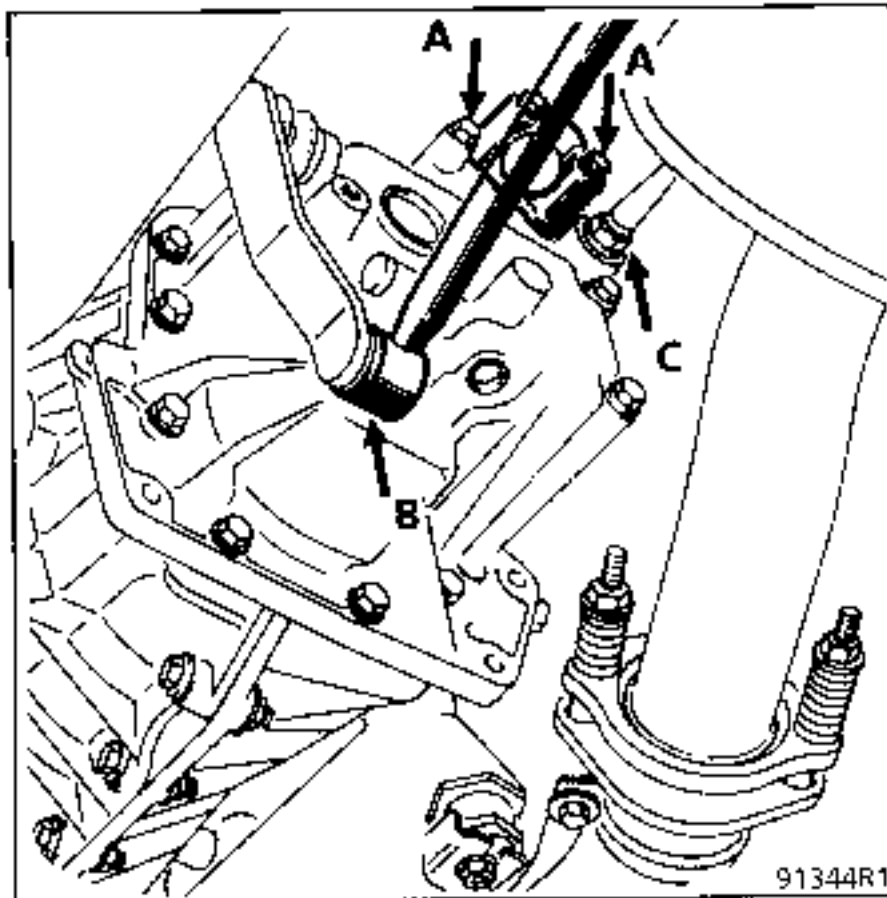

- the 5th gear locking ball plug (D).

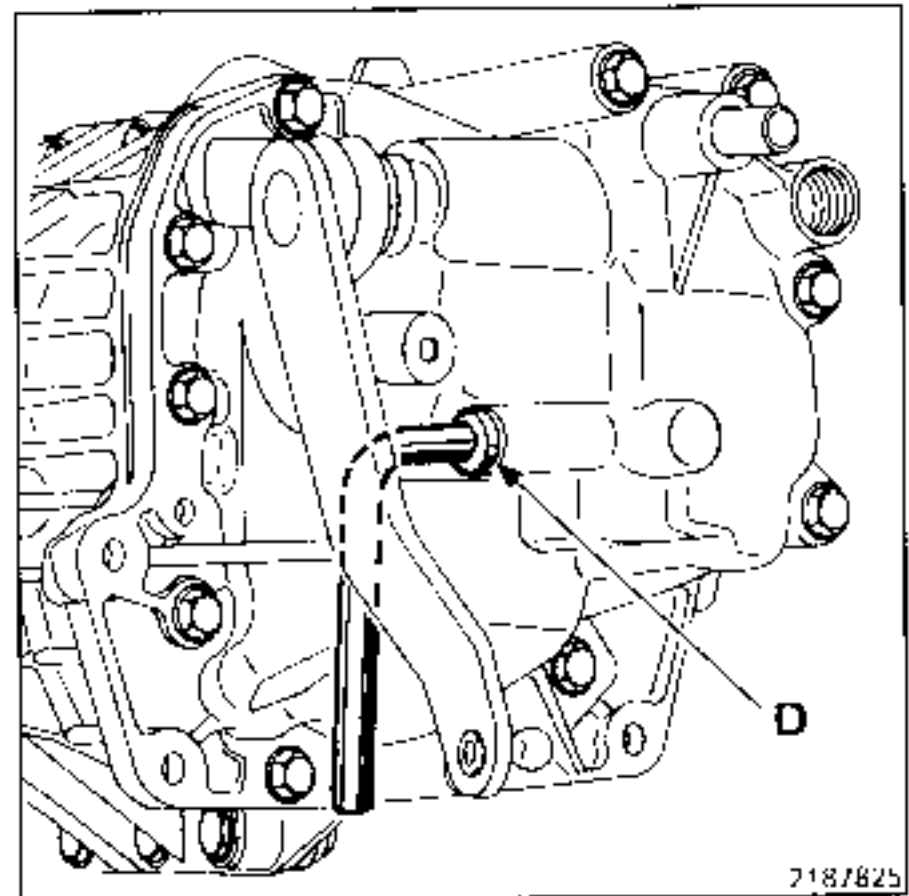

Retain the spring and the locking ball.

REMOVAL - REFITTING (cont)

- the roll pins (G) : internal diameter 4 mm
external diameter 7 mm
- the sleeve (E),

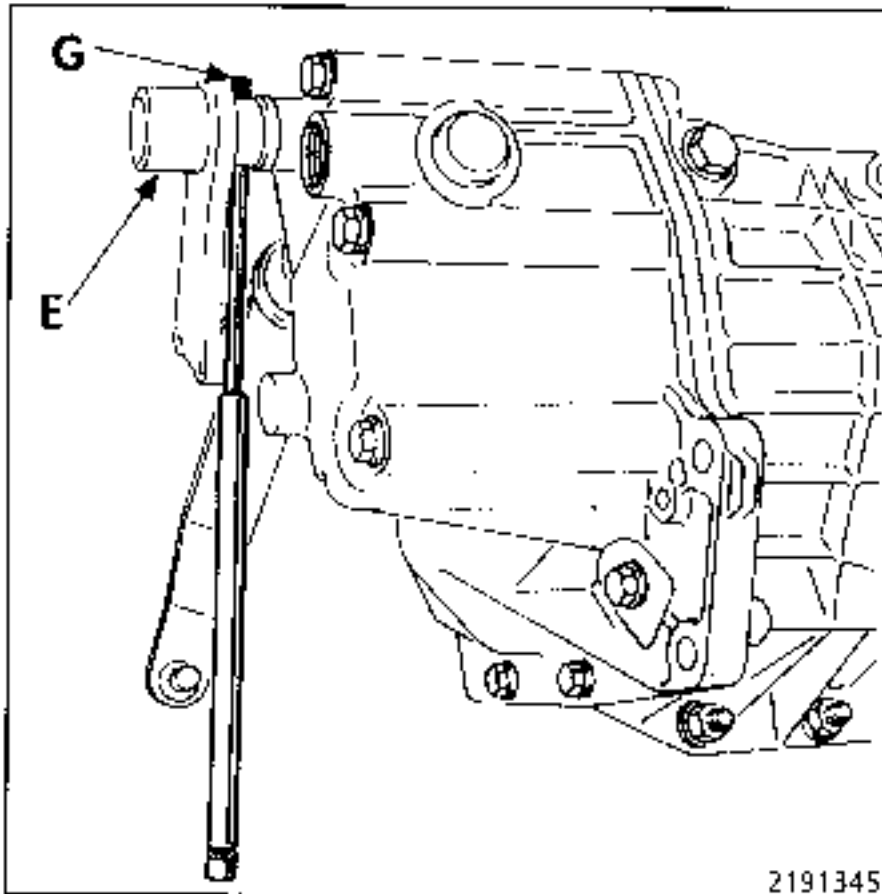

2191345

the rear housing mounting bolts.

With the gearbox in neutral, remove the housing by pushing at the same time on the tilting locking shaft.

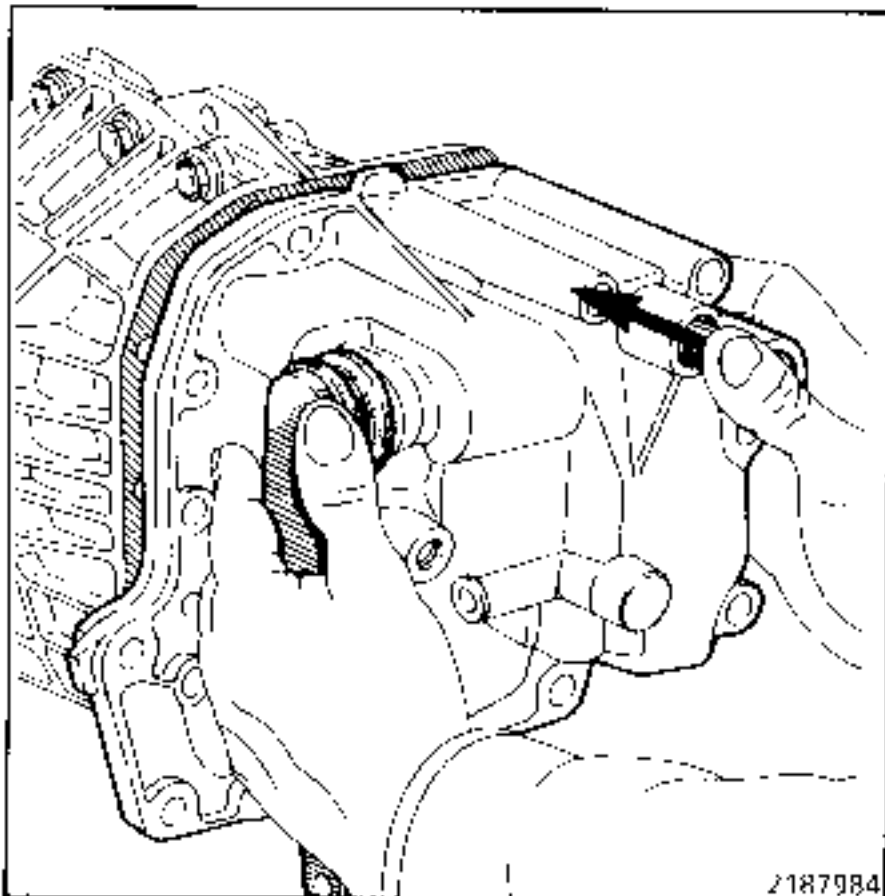

2187984

Select two gears: reverse and 4th.

Release and slacken the primary and secondary shaft nuts.

On the primary shaft

Fit an extractor tool (eg- **FACOM U32-120**) or equivalent and the shaft protecting end piece **Rou. 15-01** and extract the 5th gear assembly: idle gear, sliding gear, fork shaft, synchro ring and dog clutch.

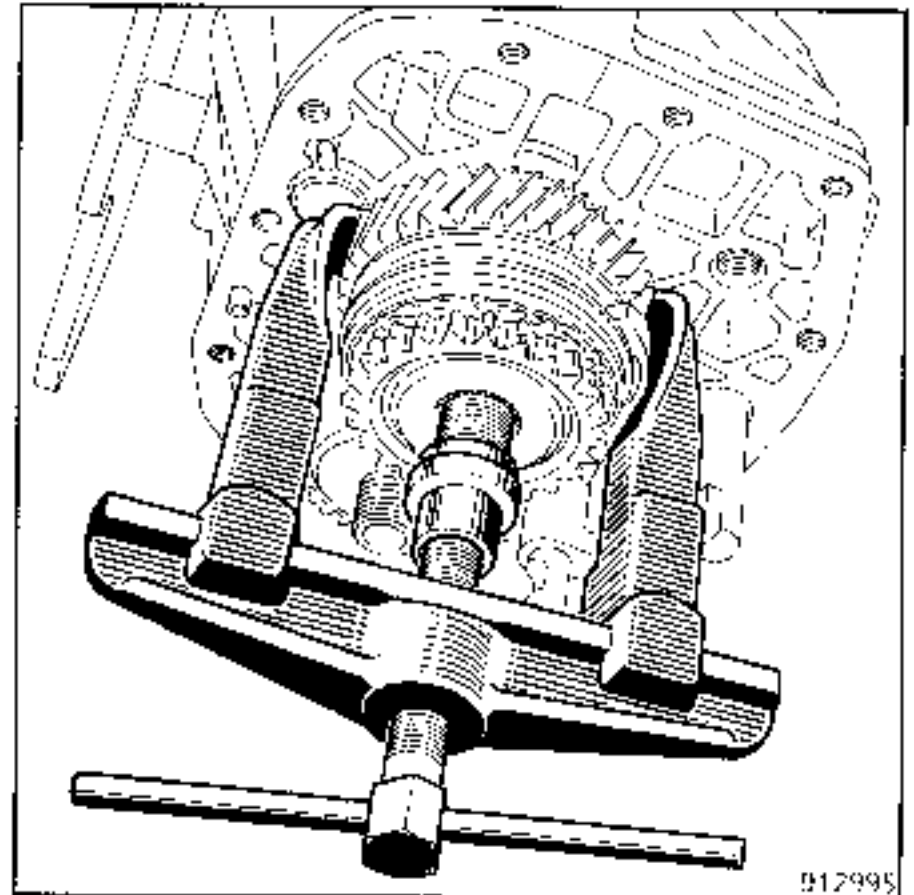

912995

REMOVAL - REFITTING (cont)**On the secondary shaft**

Remove the fixed gear using tool **B.Vi. 28-01** with jaws **B.Vi. 1007** and the protective end piece **Rou. 15-01**.

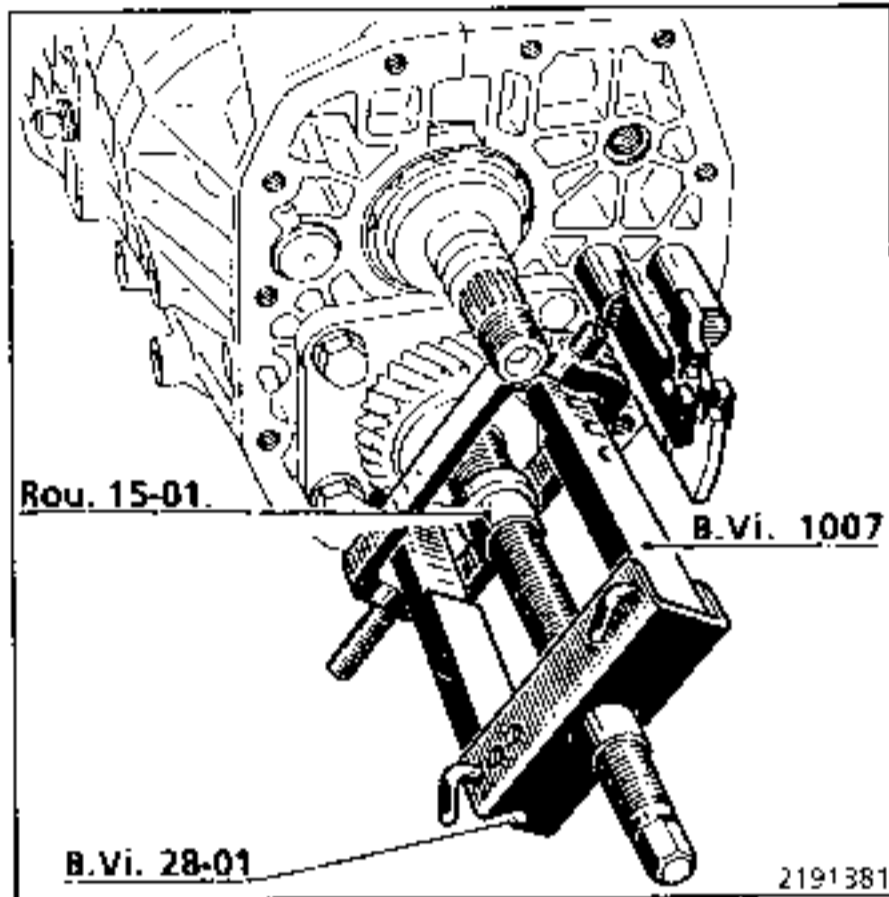
**REFITTING - Special notes****On the secondary shaft**

Ensure that the fixed gear is fitted the correct way round and bond it using **LOCTITE SCELBLOC**.

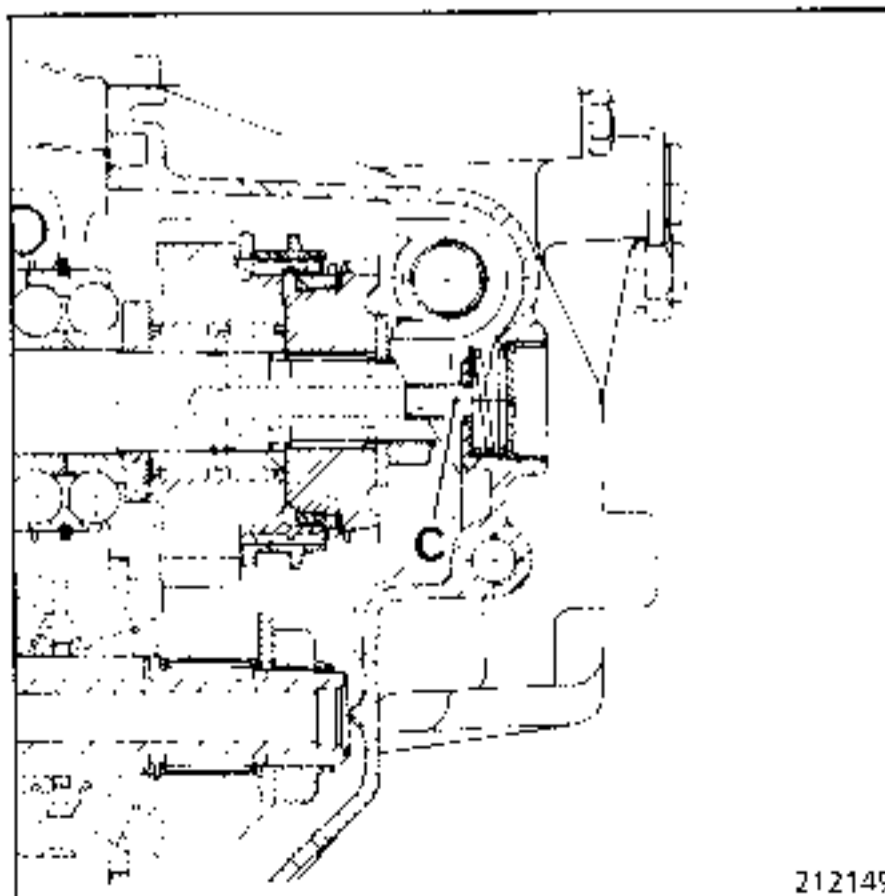
**On the primary shaft**

Refit the 5th gear synchro assembly: idle gear, sliding gear, fork shaft.

Place the bosses on the synchro ring in the notches on the hub.

Bond the dog clutch using **LOCTITE SCELBLOC**.

Apply 3 drops of **LOCTITE FRENBLOC** to the threads of the new nuts, torque tighten them then lock them.

Return the gearbox to neutral.

Fit the rear housing (seal coated with **PERFECT-SEAL**) taking care to fit the selector finger and the tilting latch in the shaft dog clutches.

Torque tighten the bolts.

Fit the anti-dust washer to the shaft and fit roll pins to the selector lever sleeve, ensuring they are fitted the correct way round.

The slots on the roll pins must be perpendicular to the shaft and opposite one another.

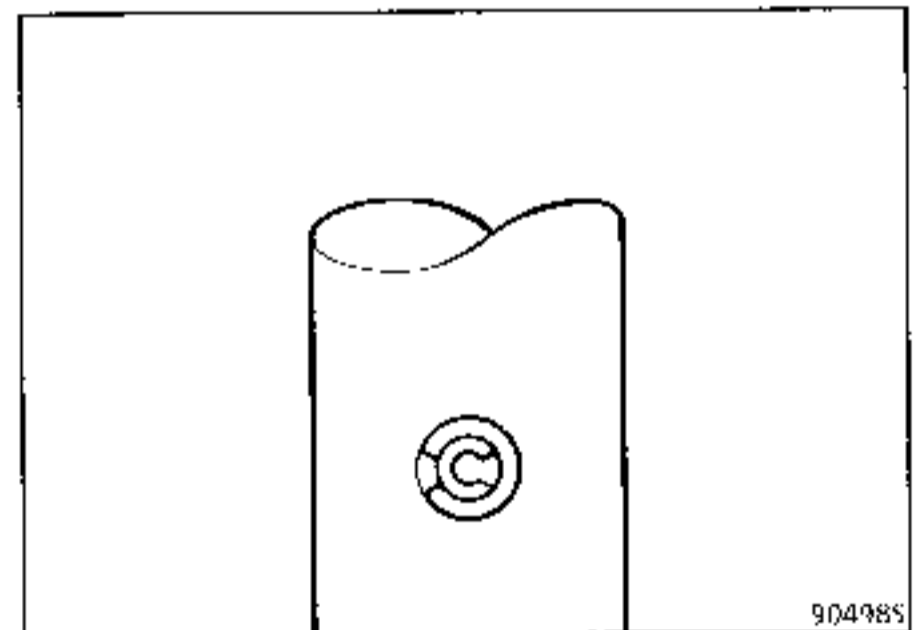

Coat the threads on the 5th gear locking ball plug with **RHODORSEAL 5661**, and also coat the reverse gear positive locking mechanism.

Check that all the gears can be selected.

Fill the gearbox with oil.

REMOVAL - REFITTING

SPECIAL TOOLING REQUIRED

B.Vi.	28-01	Extractor tool
B.Vi.	31-01	Set of 5 mm diameter punches
B.Vi.	204-01	Wrench for secondary shaft nut
B.Vi.	1007	Jaws for B.Vi. 28-01
B.Vi.	1170	5th gear hub extractor

TIGHTENING TORQUES (in daN.m)



Primary shaft nut	13
Secondary shaft nut	15
Rear housing bolt	1.5

This operation is carried out when the gearbox has been removed and the 5th speed housing removed.

Mark the hub and the sliding gear.

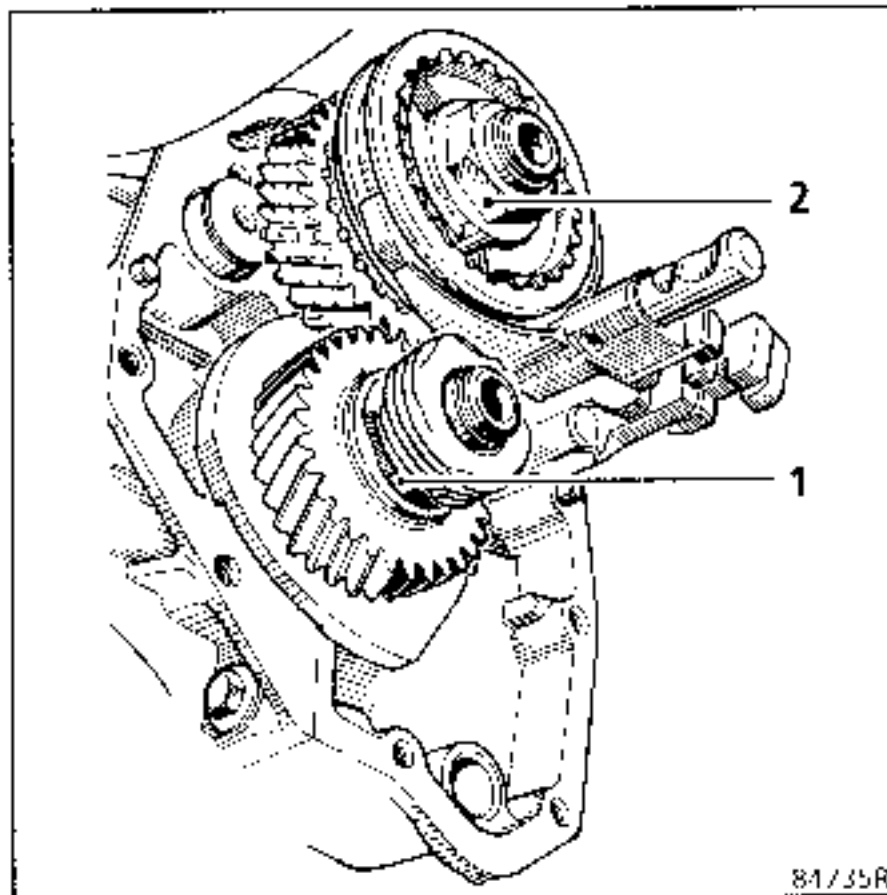

Select 1st and 5th gear.

Release and slacken the primary shaft nut (2).

Release and remove the secondary shaft nut (1) using tool B.Vi. 204-01 and a torque wrench.

When removing the 5th gear fork and shaft without separating the half housings, the gearbox must be positioned at the reversing lights switch end so that the locking ball does not fall into the gearbox.

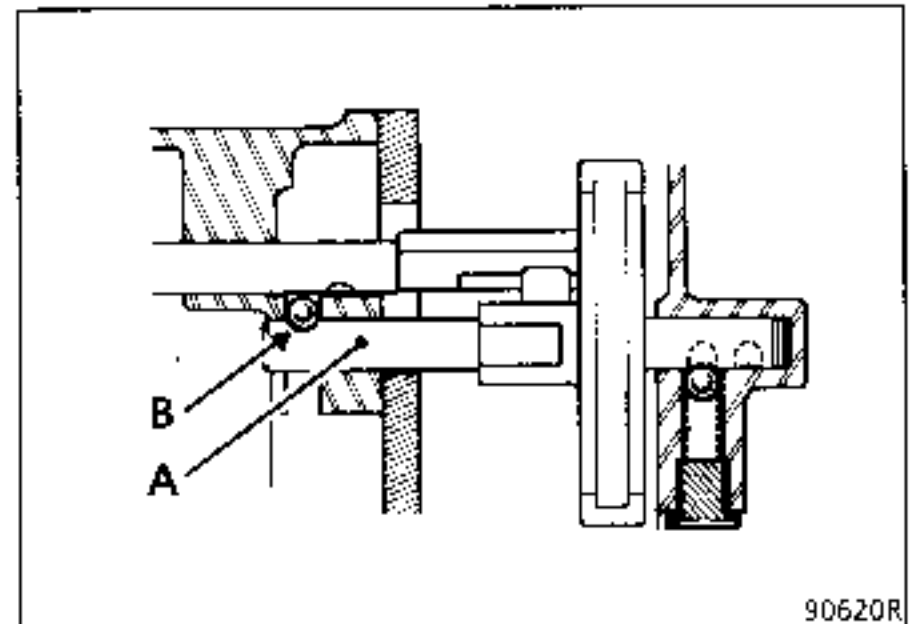

Return the gearbox to neutral.

Remove the 5th gear shaft / fork assembly and the sliding gear at the same time.

Remove the hub using tool B.Vi. 1170.

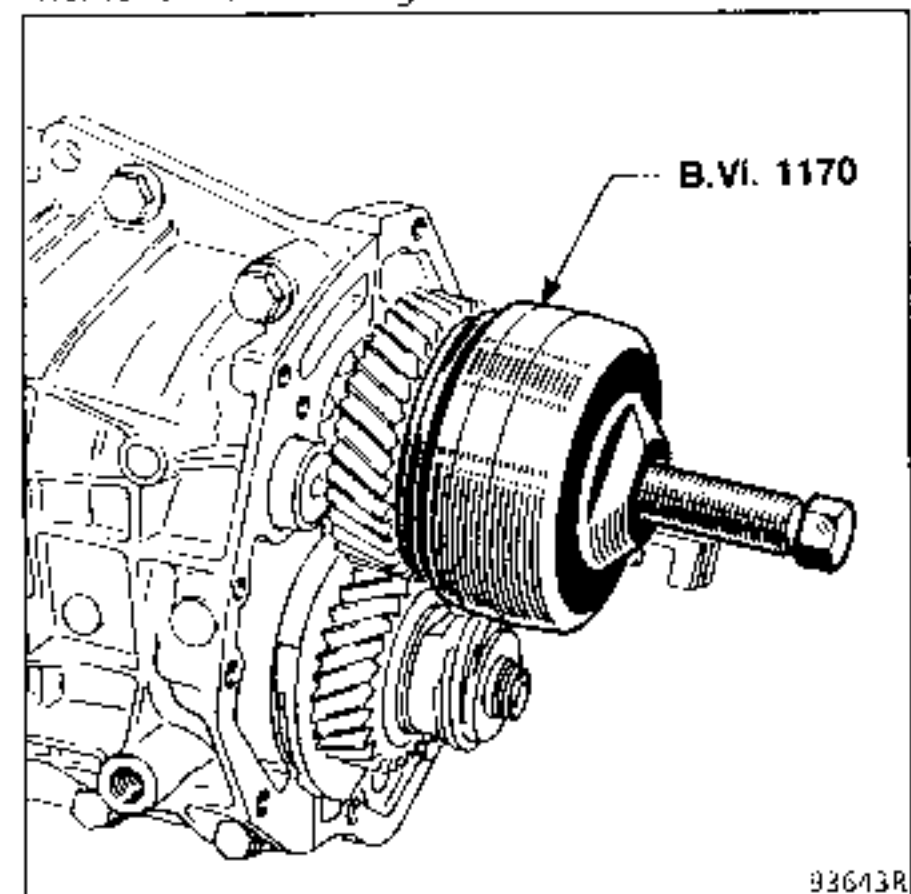

REMOVAL - REFITTING

Remove the 5th gear idle gear, the bearing and the bush.

Remove the 5th gear fixed gear using tool **B.Vi. 28-01** with jaws **B.Vi. 1007**.

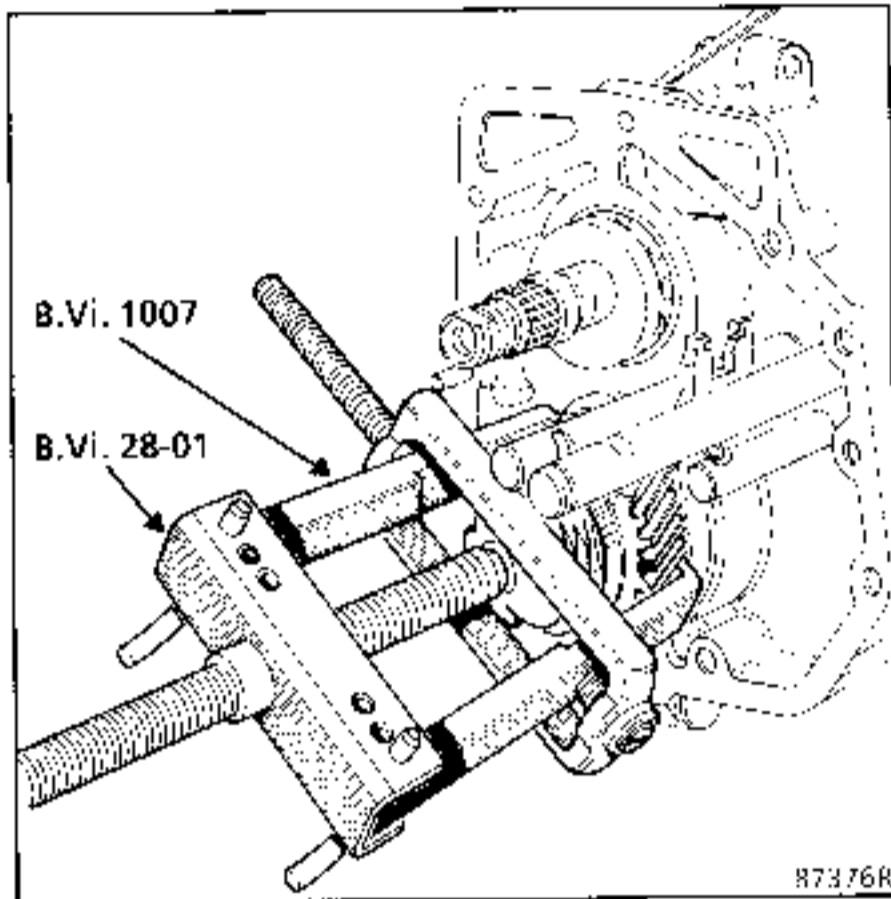
**REFITTING**

Refitting is the reverse of removal.

On the secondary shaft

Ensure the fixed gear is fitted the correct way round and bond it using **LOCTITE FRENBLOC**.

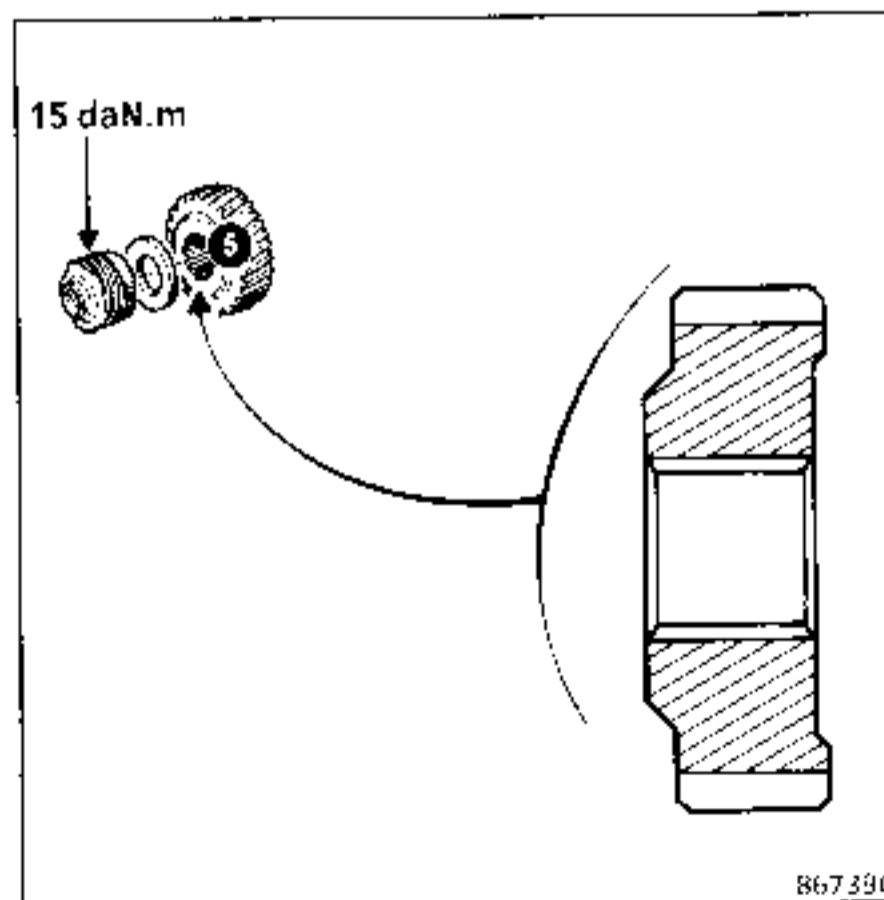
**On the primary shaft**

Bond the hub using **LOCTITE FRENBLOC** and ensure the assembly is fitted the correct way round.

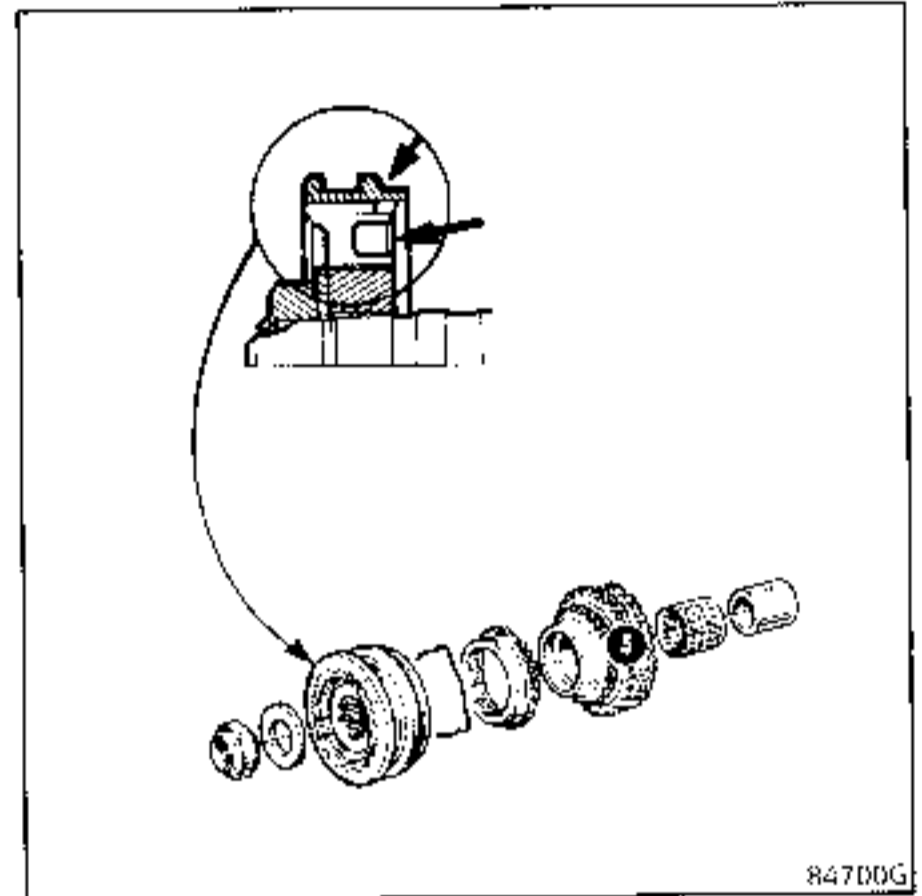

Place the bosses on the synchro ring in the notches on the hub.

Refit the 5th gear synchro assembly, the hub - sliding gear and the fork shaft.

Select 1st gear and 5th gear.

Apply 3 drops of **LOCTITE FRENBLOC** to the threads of the new nuts, torque tighten them and lock them:

- primary shaft : **13 daN.m,**
- secondary shaft : **15 daN.m.**

Refit the 5th gear housing.

Check that all the gears may be selected.

REPLACEMENT

From these fabrication numbers onwards, see the table below, kit Part Number : 77 11 106 100 may be adapted for replacing the 5th gear linkage on NG gearboxes except for NG7.

Vehicle fabrication numbers from which adaptation is possible.

RENAULT 21				
Vehicle type	Fabrication number			
L483	E 052145	S 060157	H 001114	
L486		S 025850	H 014509	U 070022
L488		S 015122	H002212	U 031112
L48V		S 001152	H 000734	
L48K		S 001526		
L48Q		S 000021		
K483	E 006208		H 012877	
K486	E 002360		H 030664	
K488	E 000865		H 010480	
K48V			H 000076	
K48K			H 003087	
S486			H 004089	
S48V			H 000191	

NOTE:

All R21 vehicles fitted with an NG gearbox may be fitted with this kit.

Before any adaptation of the kit, the operation of the clutch must be checked as if it is not correct, the reverse gear brake may not operate correctly.

Initial checks:

a) Check the clutch travel at the clutch fork at the gearbox end.

Travel : **18 to 20 mm.**

If the travel is less than **18 mm**, look for the fault at the control end (pedal assembly, cable, carpet thickness, etc.).

b) Check the clutch disc is correctly released.

- Engine and gearbox at operating temperature.
- Let the clutch out, wait for **3 seconds** (delay required for the clutch disc to stop).
- Engage reverse gear. If it makes a noise when engaging, there is a fault with the clutch itself):
 - . sliding of the disc on the clutch shaft (bevels, oxidation, incorrect disc, seizing, etc.),
 - . fault with the mechanism (plate lifting incorrectly).

IDENTIFICATION

5th GEAR SHAFT

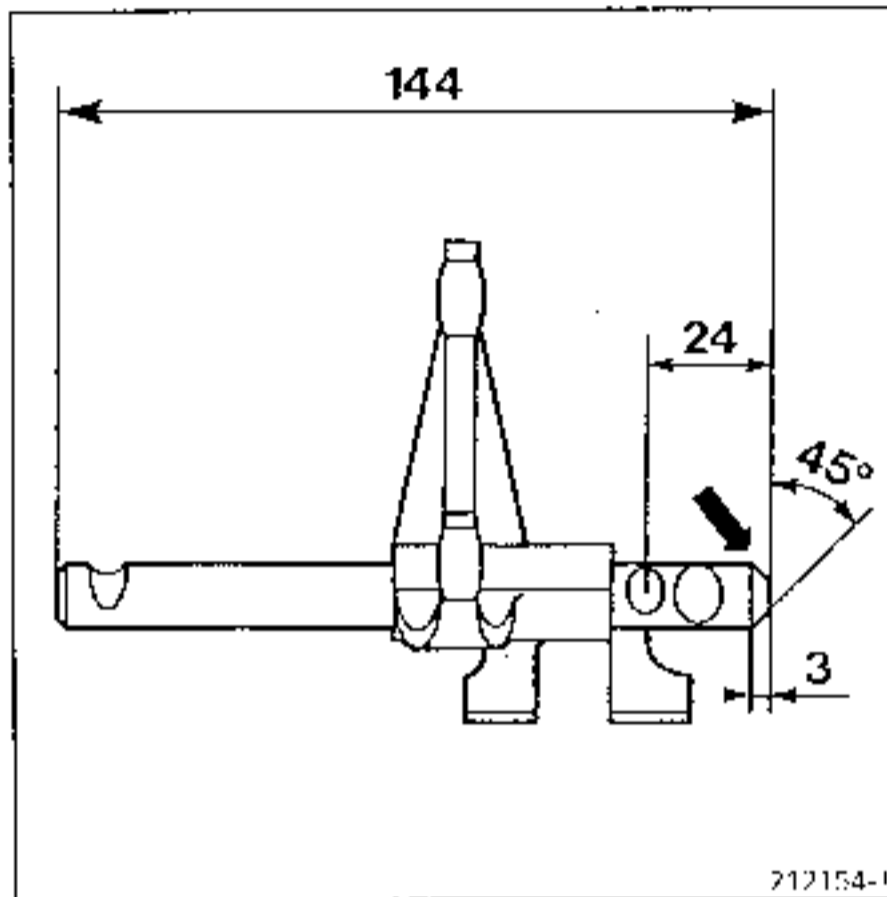
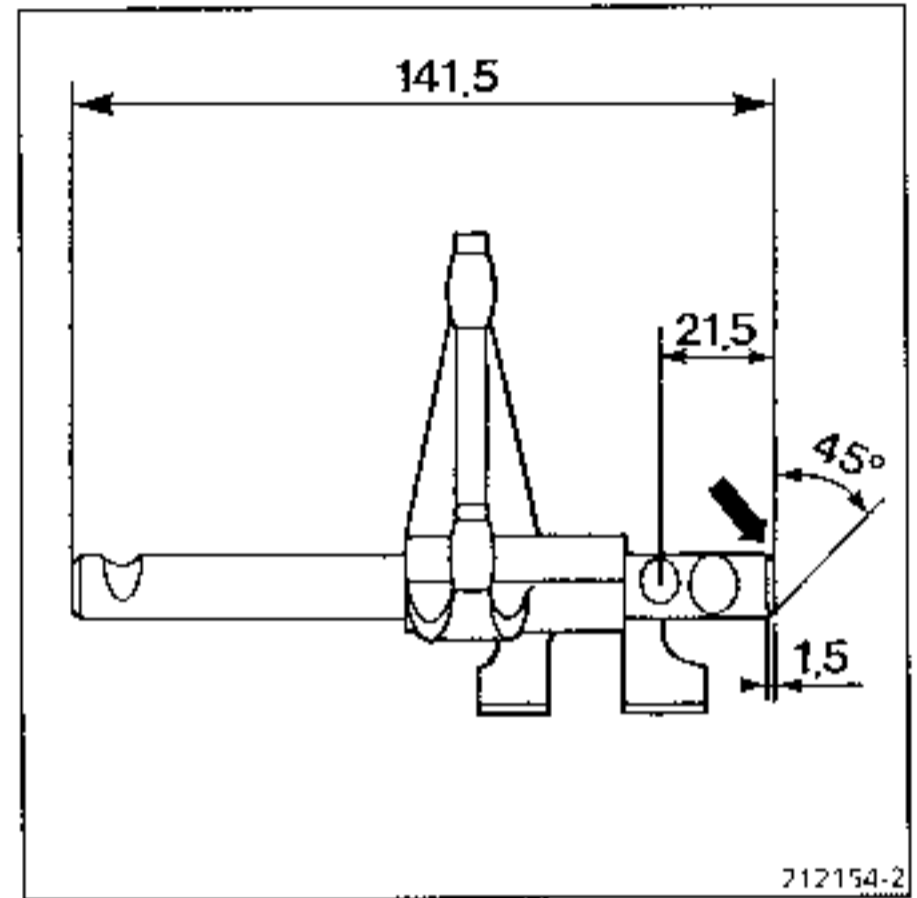
Shaft to which the kit **cannot** be fitted.Shaft to which the kit **can** be fitted.

The Parts Department only supplies shafts of length 141.5 mm.

REAR HOUSING

- The housing is machined at (A). This opening is covered by a plug on the vehicle.
- The gear selector (B) must be triangular and must have a bearing (C).

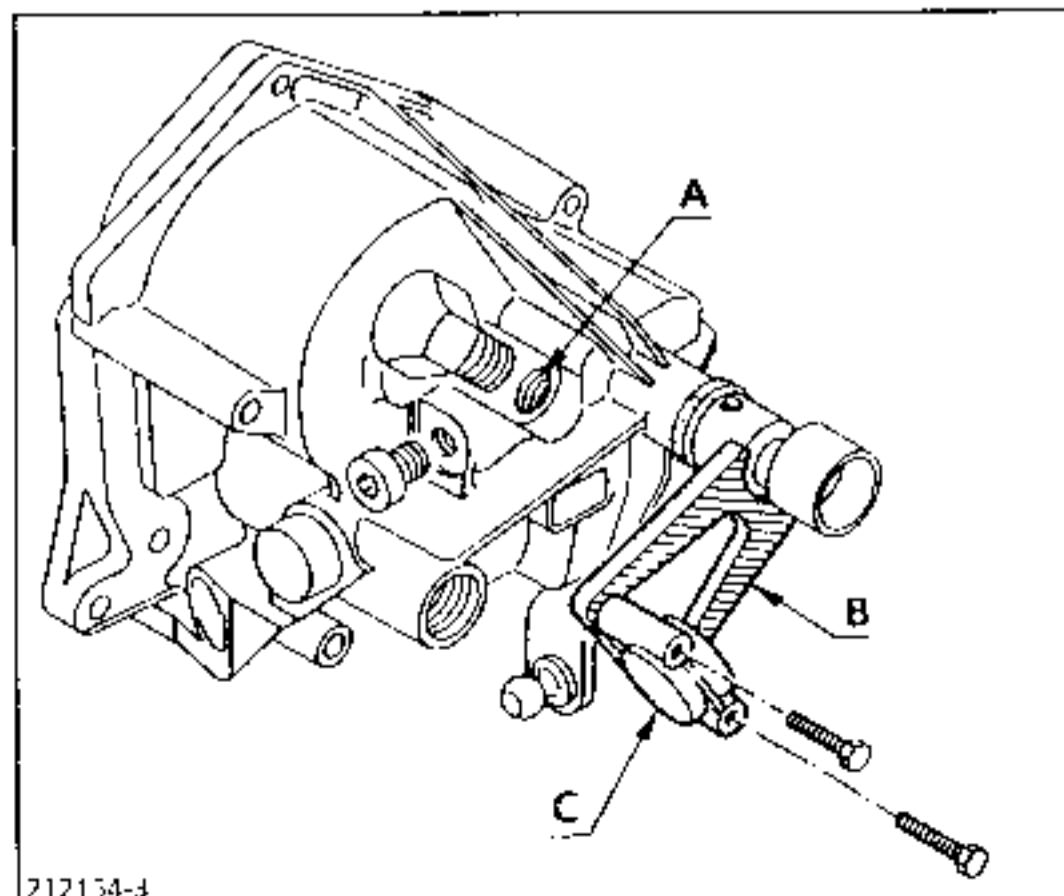

DESCRIPTION OF THE KIT

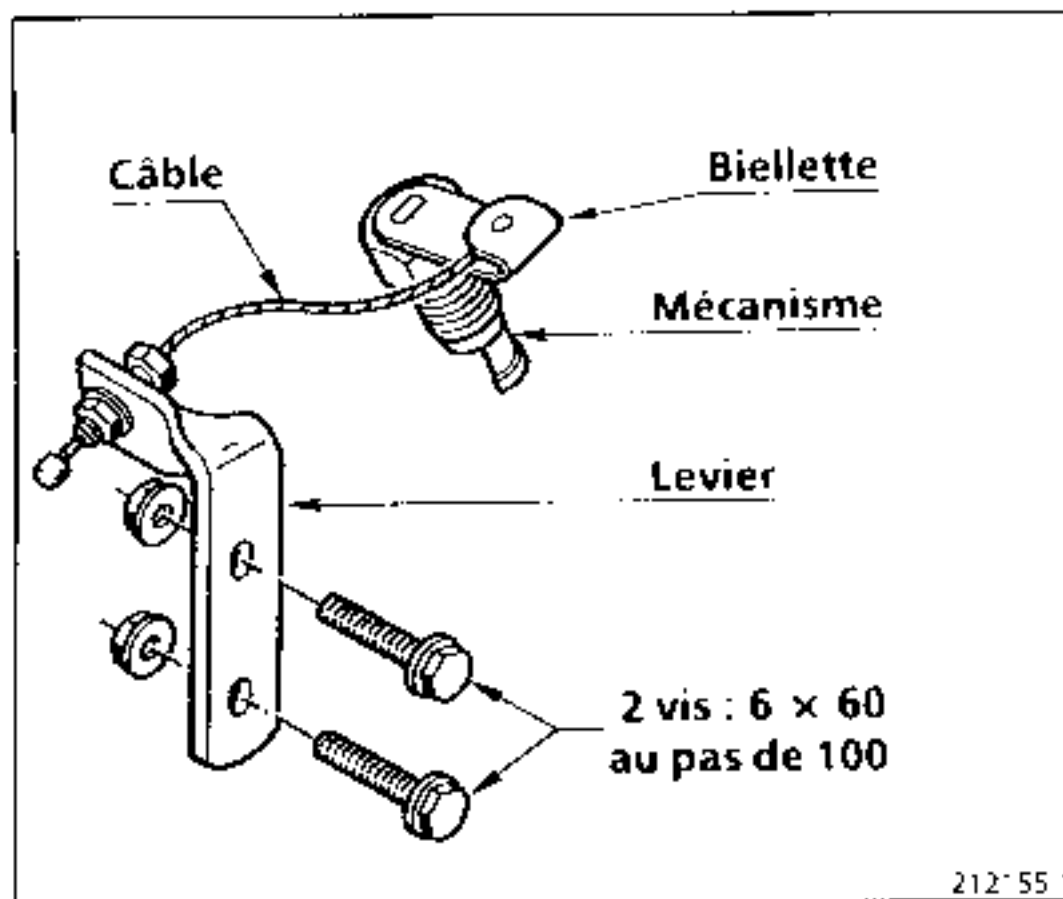

OPERATING PRINCIPLE

When reverse gear is selected, the selector lever (B) on the gearbox pulls the cable while acting on the cam.

When the cam moves round, it pushes gently against the 5th gear shaft which brings the synchro cone into contact with the 5th gear, thus braking the rotation of the primary shaft.

NOTE : as the primary shaft is stopped from rotating, this system may cause blockages when reverse gear is selected.

ADAPTATION

- Remove the two mounting bolts for the bearing (C) and replace them with those supplied in the kit (diameter 6 mm - length 60 mm - thread 100).
- Certain vehicles are fitted with washers between the bearing (C) and the gear selector (B). Remember to fit these washers.
- Remove the bolts (1) and (2), retain the spring and the 5th gear resistance ball.

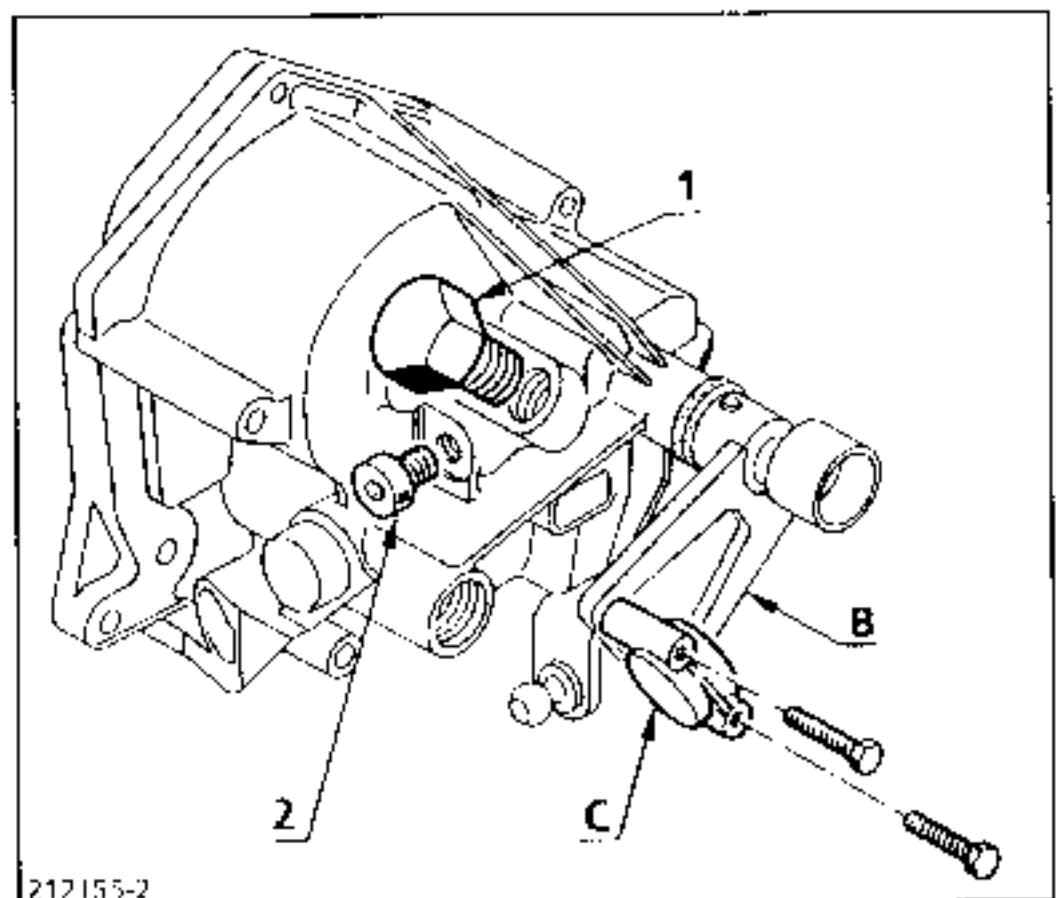

- Insert the 5th gear.
- Coat the threads of the mechanism (3) with a few drops of **LOCTITE FRENETANCH**.
- Fit the mechanism (3) into the machined location and tighten moderately.

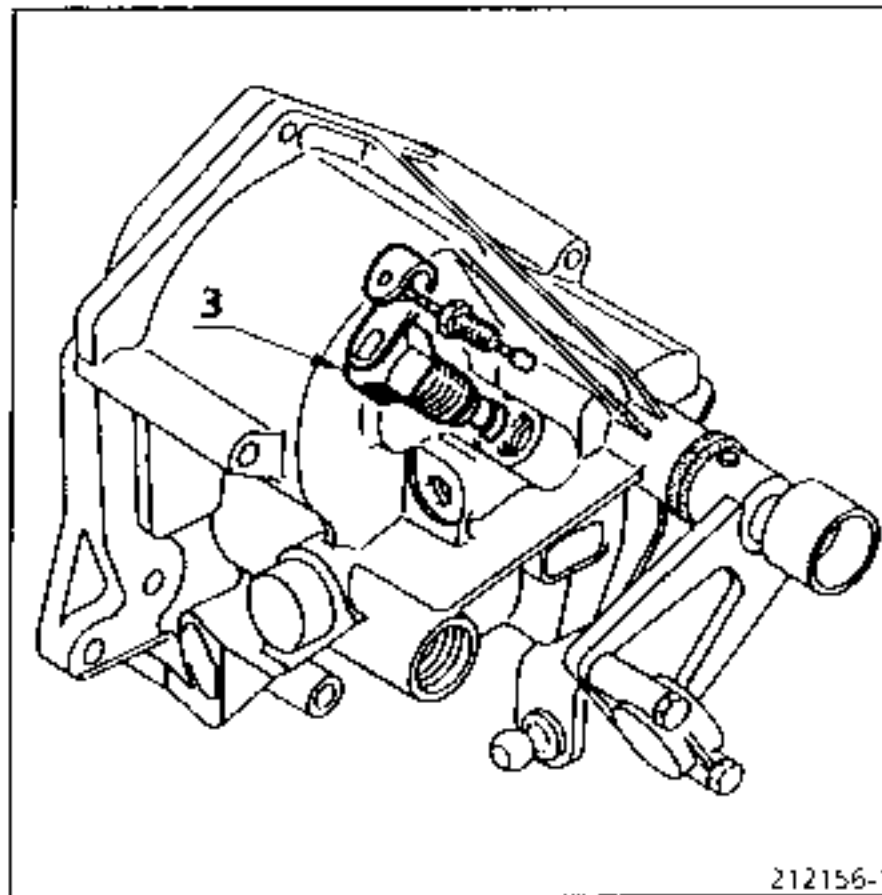

Fit:

- the lever (4) on the gear selector (B) ; lock the assembly using nuts (5).
- the cable on the lever (4).

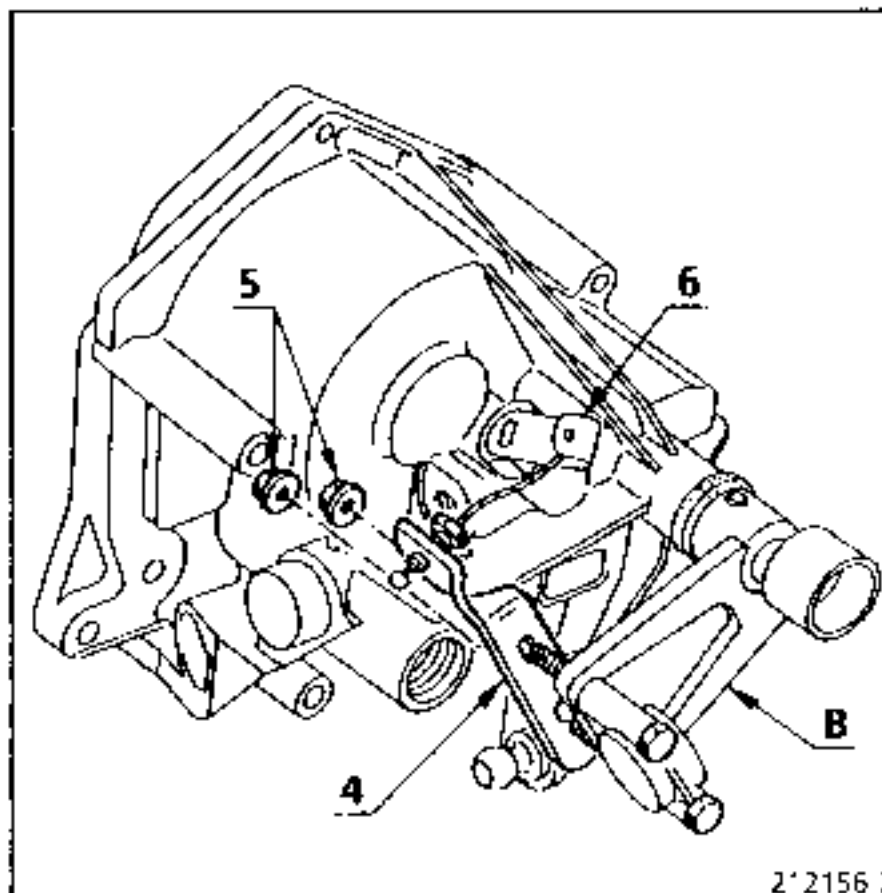

Return the gearbox to neutral and check that 3rd and 4th gears can be correctly selected.

Fit the ball and the resistance spring for 5th gear and refit the plug (2).

IMPORTANT NOTE: do not move the bar (6) by hand as the 5th gear shaft will move forward and exceed the locking ball notch position.

If this happens, try to release the assembly by engaging 2nd gear.

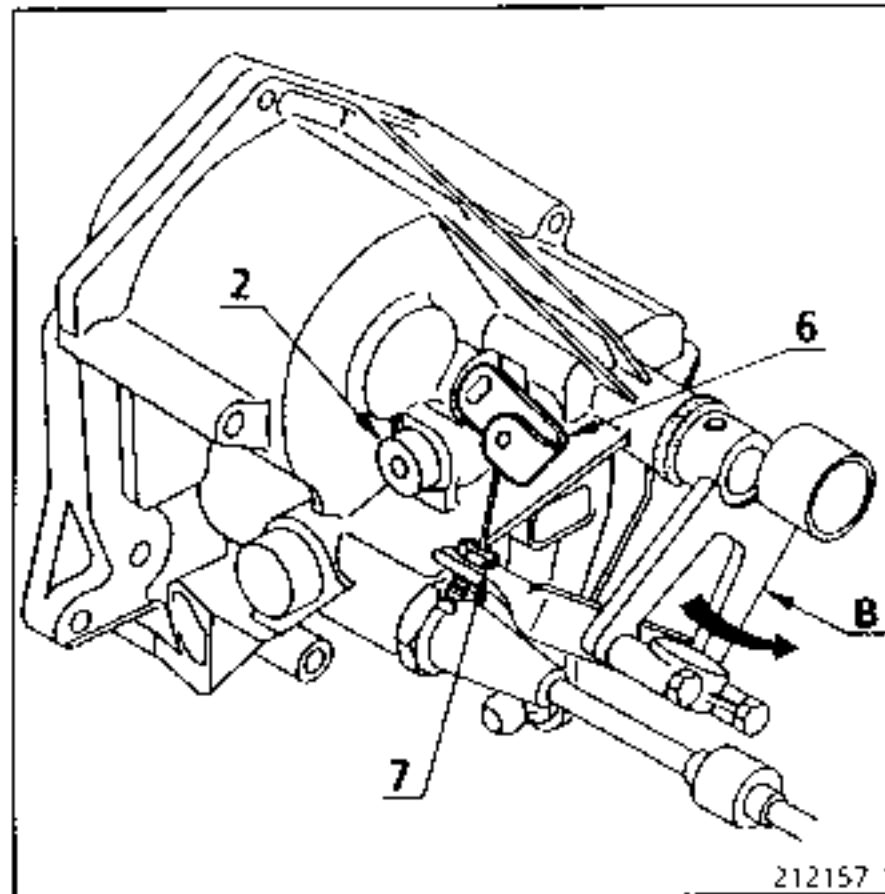

With the reverse gear shaft locking cable in position, tilt the lever (B) downwards (see arrow) without releasing reverse gear.

Bring the bar (6) against the 5th gear shaft, without forcing it.

In this position, adjust bolt (7) until the cable is taut but not stretched.

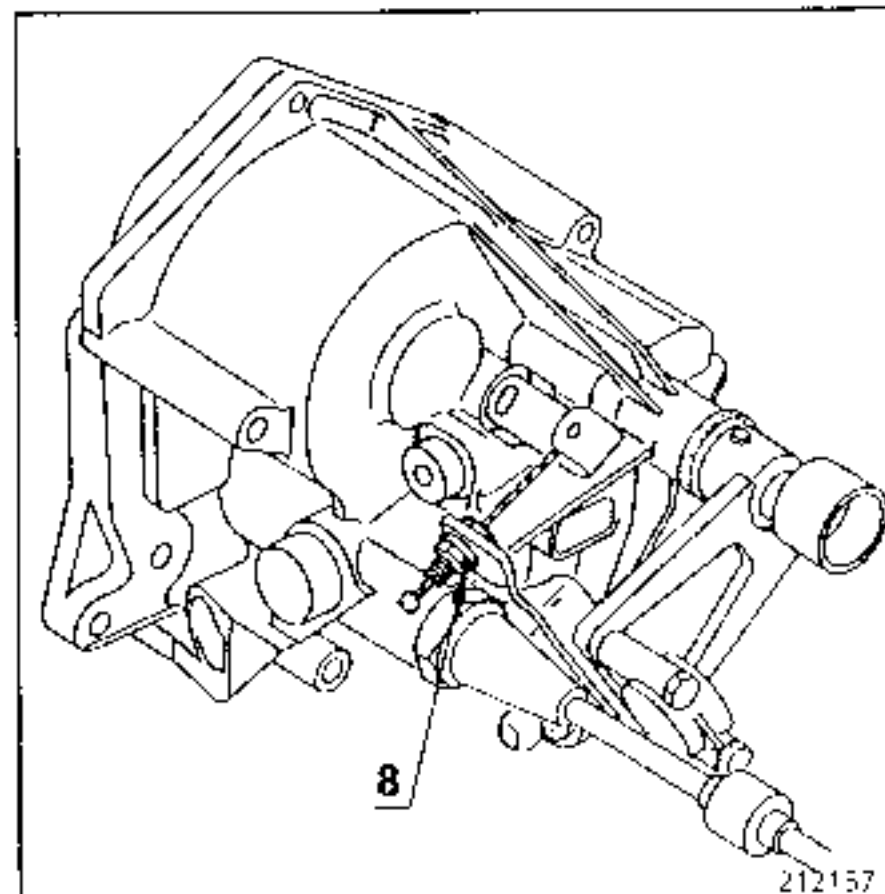

Lock the lock nut (8).

SPECIAL NOTES FOR ADJUSTMENT

The 5th gear shaft returns to the neutral position thanks to a 5th gear resistance ball and spring pressing against the shaft locking ball rail.

The efficiency of the system may be increased by turning bolt (7) one or two additional turns. In this configuration however, it is vital to check after engaging reverse gear several times that the 5th gear shaft is returning to neutral correctly.

If the shaft does not return to neutral, it will be impossible to select 3rd gear after selecting reverse since the locking ball between the shafts for 3/4 and 5th gear will prevent selection.

In this case, slacken the cable until the shaft returns to neutral correctly.

The paper seal which has until now sealed the rear housing for "NG" type gearboxes, has now been replaced by a thicker "VULCOFLEX" seal.

To enable this new seal to be fitted, the rear housing sealing face has been reduced by 0.5 mm.

Consequently, the correct type of seal must be fitted for the housing type.

To identify the housings, measure the dimension "X" between the sealing face and the secondary bearing face or consult the application numbers table.

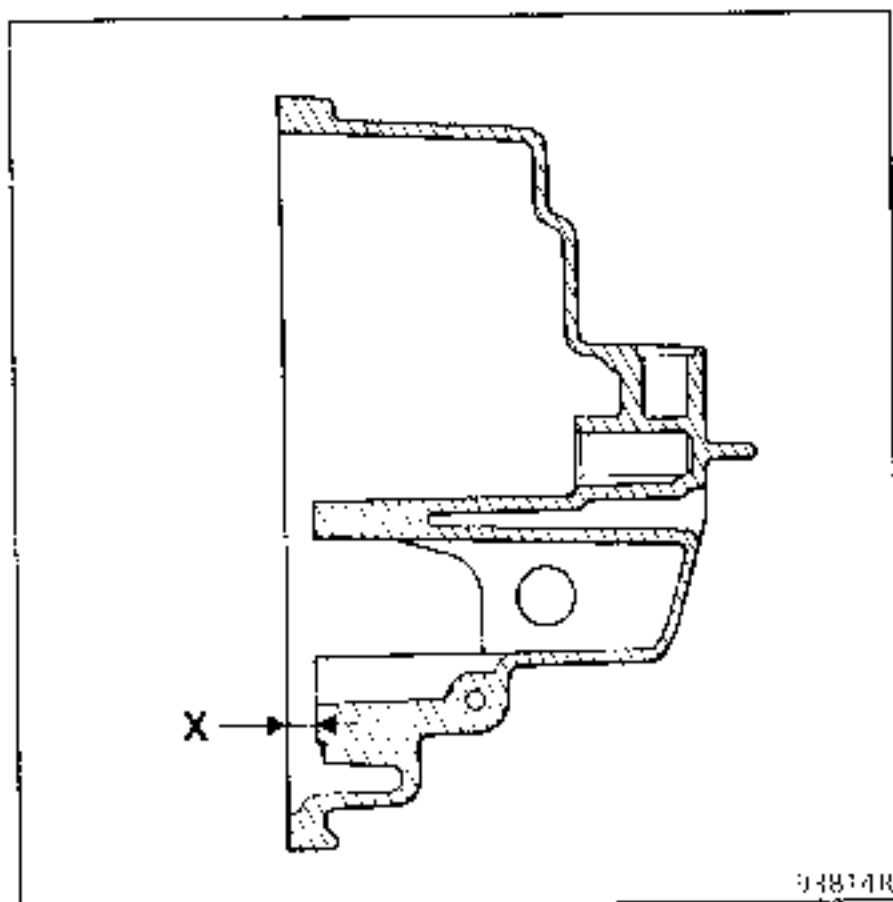

1st assembly

$$X = 8 \pm 0.03 \text{ mm.}$$

Assembly : with paper seal (thickness = 0.4 mm)
coat with **PERFECT SEAL LOWAC**

2nd assembly

$$X = 7.48 \pm 0.03 \text{ mm.}$$

Assembly : with **VULCOFLEX** seal (thickness = 0.8 mm) fit dry.

Rear housing mounting bolts tightening torque :
1.6 to 2 daN.m.

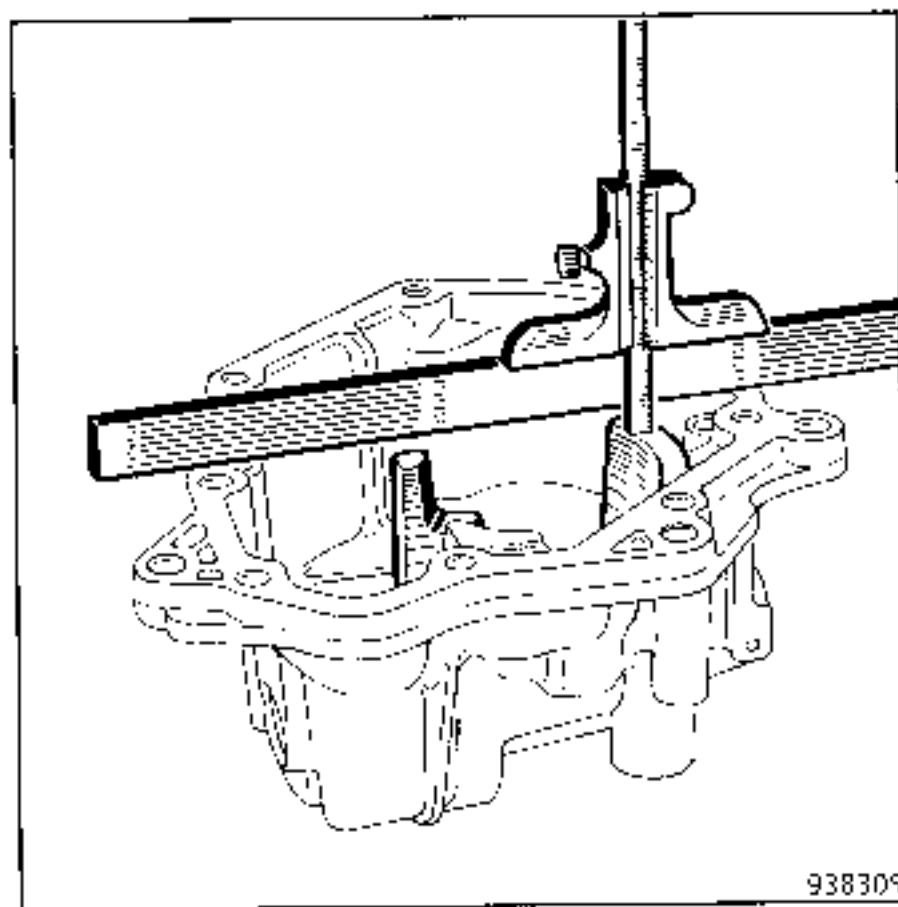

The 2nd assembly applies from the following numbers

NG9	
Suffix	Application number
00	149145
01	74416 to 74596
01	74705
02	175194
03	6890
06	16312
07	305
08	1924
09	142

SPECIAL TOOLING REQUIRED

B.Vi.	31-01	Set of punches
T.Av.	476	Ball joint extractor
B.Vi.	945	Mandrel for fitting differential seal
B.Vi.	1058	Mandrel for fitting differential seal (JB2 and JB3 with tapered bearings)

TIGHTENING TORQUES (in daN.m)



Brake caliper mounting bolt	10
Shock absorber base mounting bolt	11
Track rod end	3.5
Wheel bolts	9

REMOVAL

Remove the engine undertray.

Drain the gearbox.

Place the front right hand side on an axle stand.

Remove the wheel.

Remove the driveshaft roll pins using tool **B.Vi. 31-01**.

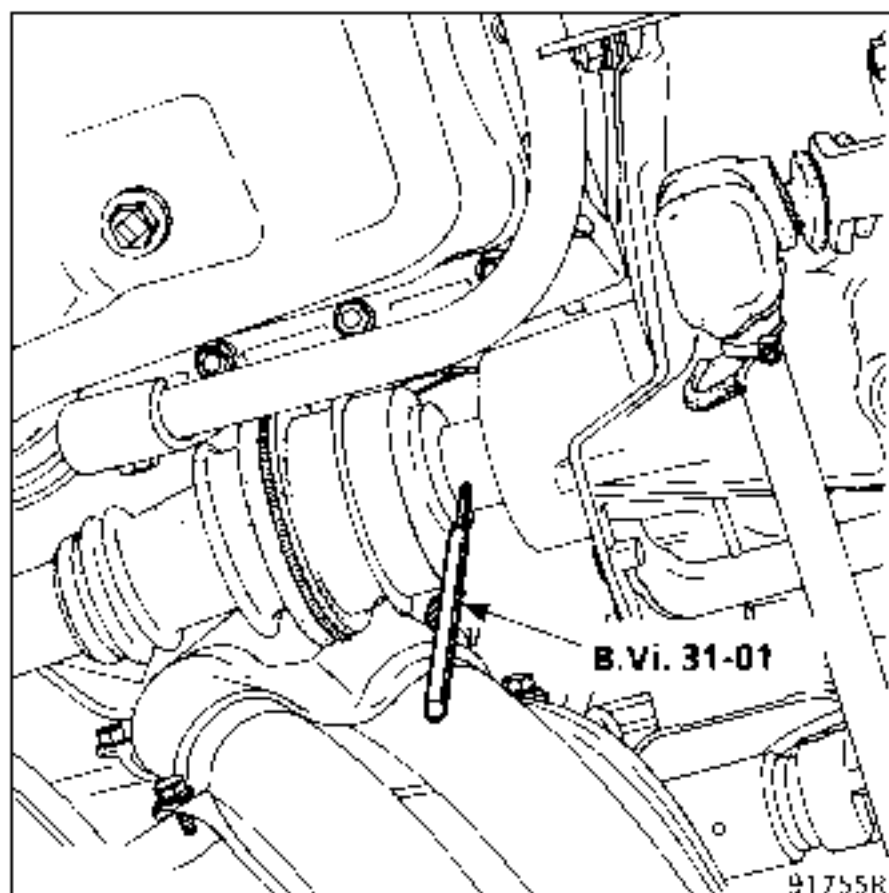

INGREDIENTS

LOCTITE FRENBLOC

Brake caliper mounting bolts

RHODORSEAL 5661

Ends of driveshaft roll pins

MOLYKOTE BR2

Right hand sunwheel splines

Remove:

- the track rod end (tool **T.Av. 476**),

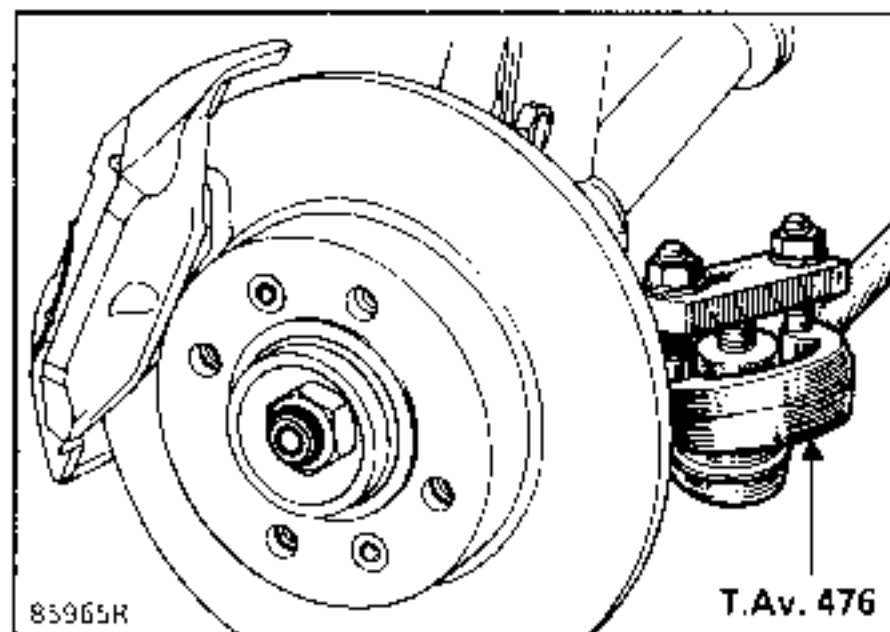

- the two mounting bolts (A) for the brake assembly.

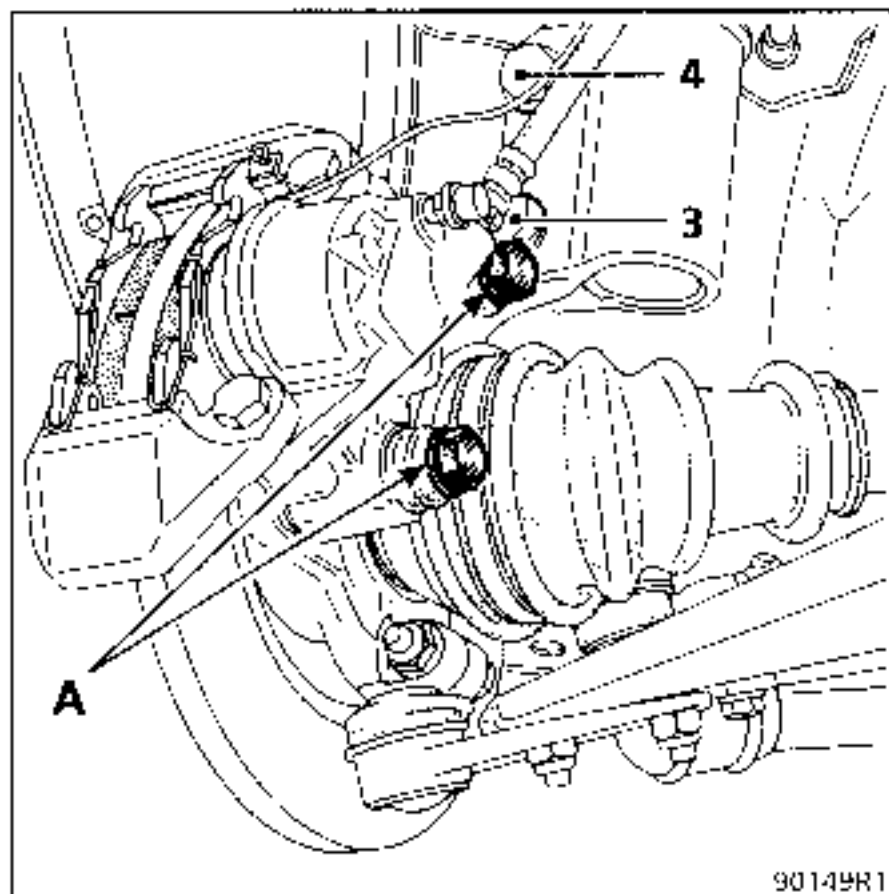

Attach the caliper to the suspension spring to prevent the hose from stretching.

Slacken the lower shock absorber base bolt (3) and remove the upper bolt (4).

Tilt the stub axle carrier and release the driveshaft (take care not to damage the gaiters during this operation).

Remove the O ring from the sunwheel.

Tap the bottom of the O ring using a roll pin punch and a small mallet to tilt it.

Once the seal has been released, remove it using pliers, taking care to avoid damaging the splines of the sunwheel.

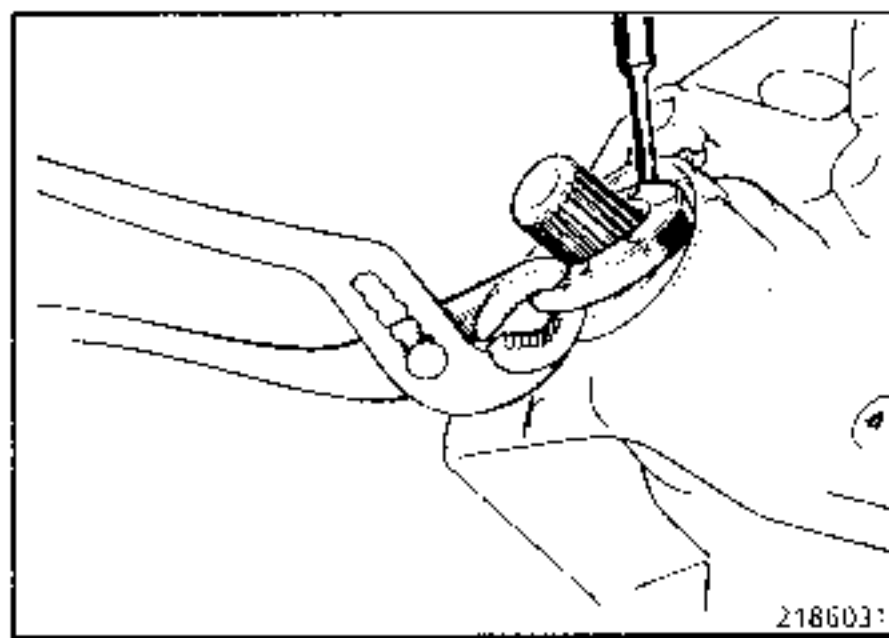

REFITTING

1. JB1 gearboxes

The seal is refitted using tool B.Vi. 945 consisting of :

- the seal protector (A),
- the seal fitting tool (B).

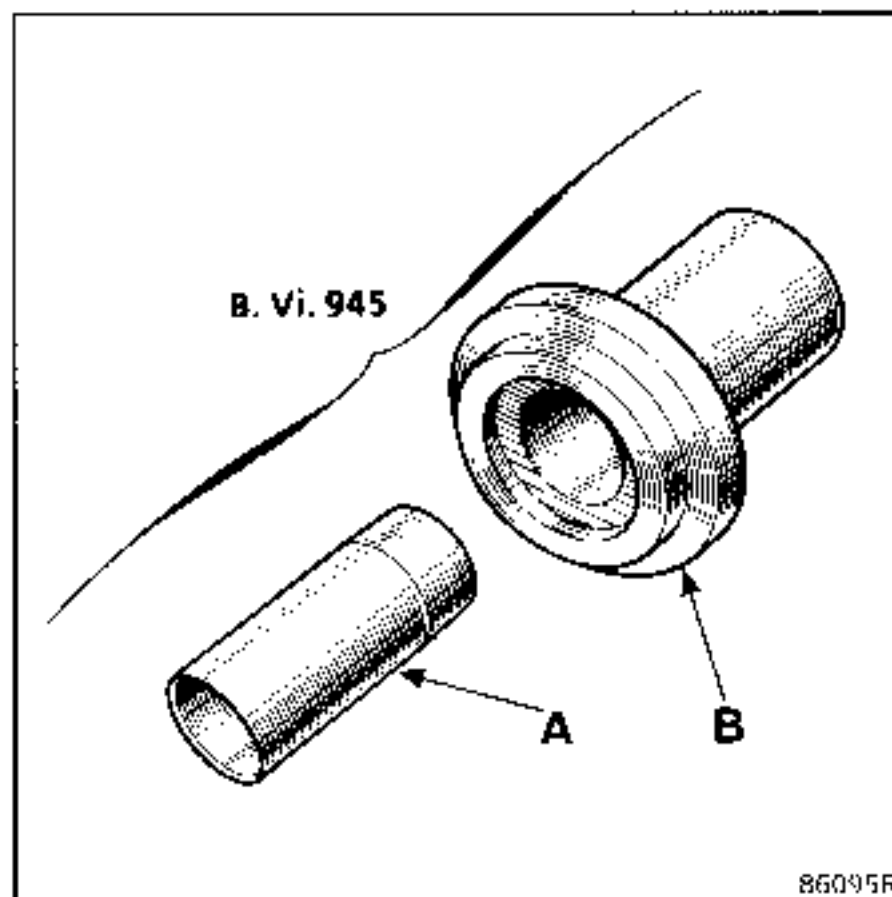

METHOD

Fit the greased protector (A) to the sunwheel and position the lubricated seal (C) using tool (B).

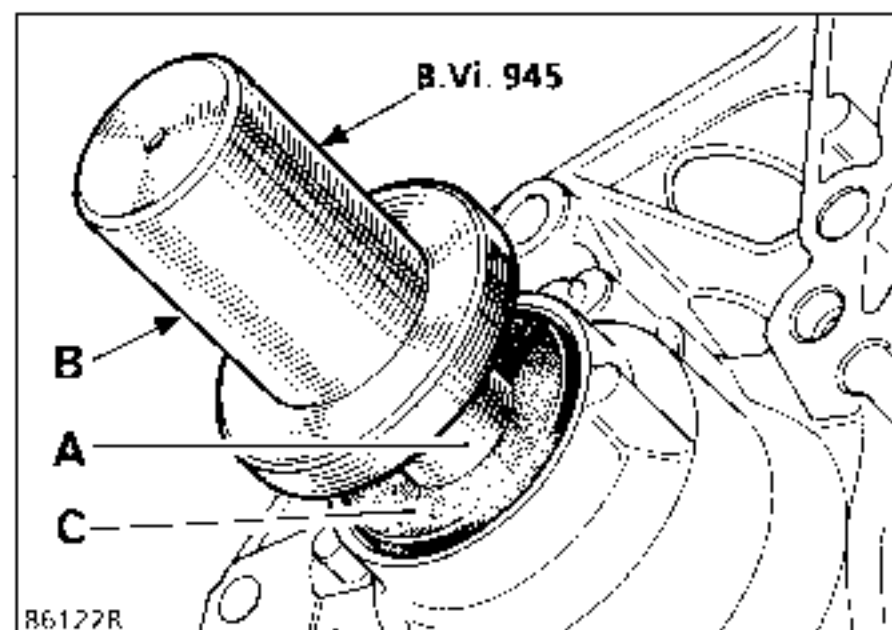

2. **JB2 and JB3 gearboxes** (differential mounted on tapered bearings).

Proceed in the same manner but use tool **B.Vi. 1058** and the protector (**A**) from tool **B.Vi. 945**.

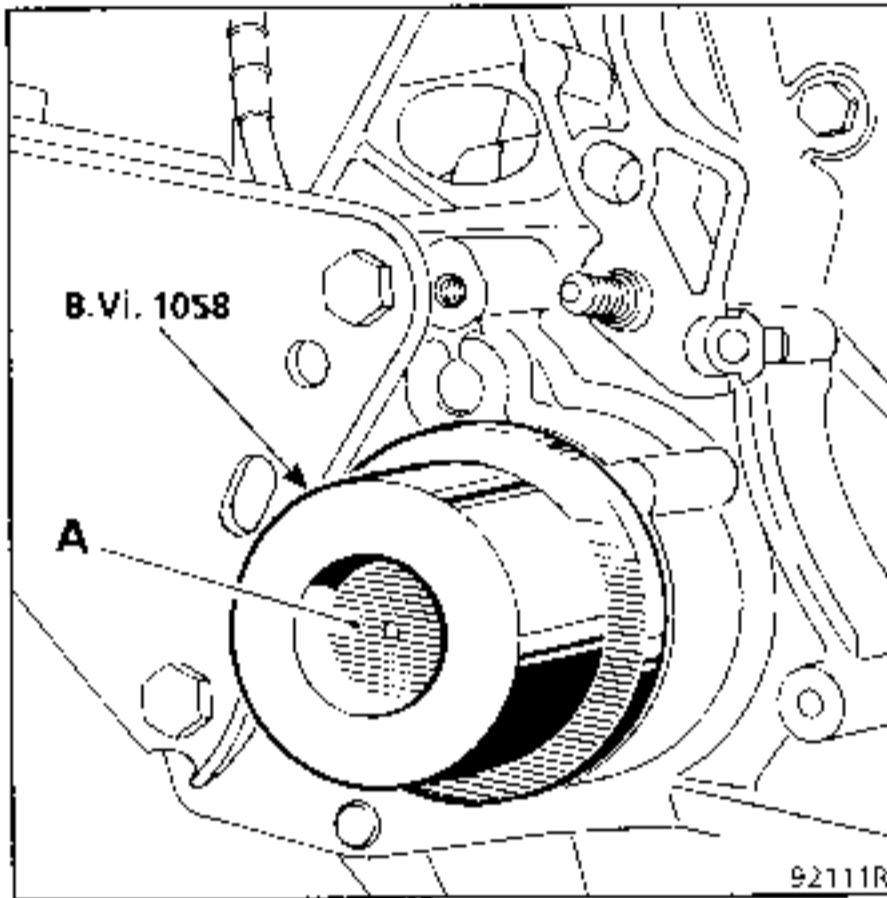

Fit the O ring on the sunwheel and coat the splines with **MOLYKOTE BR2**.

Position the driveshaft in relation to the sunwheel.

Pivot the stub axle carrier, engaging the driveshaft into the sunwheel. Use tool **B.Vi. 31-01** to align the holes.

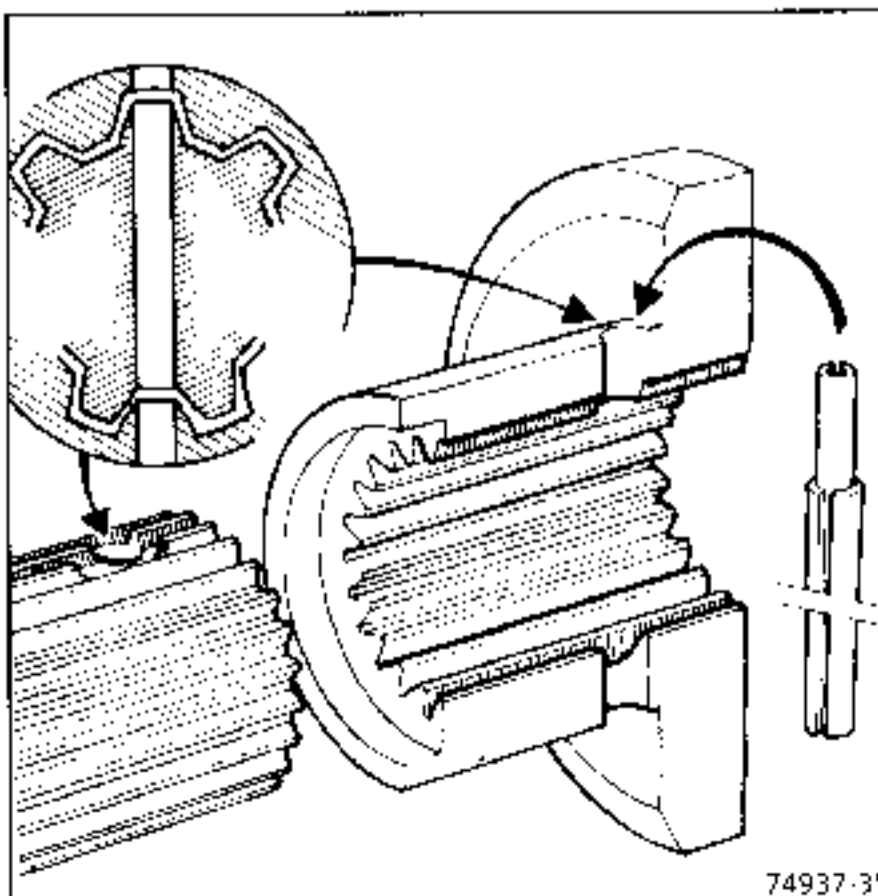

Fit the new roll pins and seal the ends using (**RHODORSEAL 5661**).



Tighten the nuts and bolts to the recommended torque.

Fit the brake caliper and coat the bolts with **LOCTITE FRENBLOC**.

Fill the gearbox with oil.

REPLACEMENT

SPECIAL TOOLING REQUIRED		
B.Vi. 807-01	Castellated wrench for differential nut	
B.Vi. 813	Seal protector	
B.Vi. 1154	Tool for fitting differential seal	

REMOVAL

Drain the gearbox.

Tilt the stub axle carriers and release the driveshaft from the sunwheel.

Mark the position of the adjusting nut in relation to the housing.

Remove the O ring and the locking plate.

Using tool **B.Vi. 807-01**, slacken the nut, counting the number of turns.

On the nut, remove:

- the O ring (A),
- the deflector (C),
- the lip seal (B).

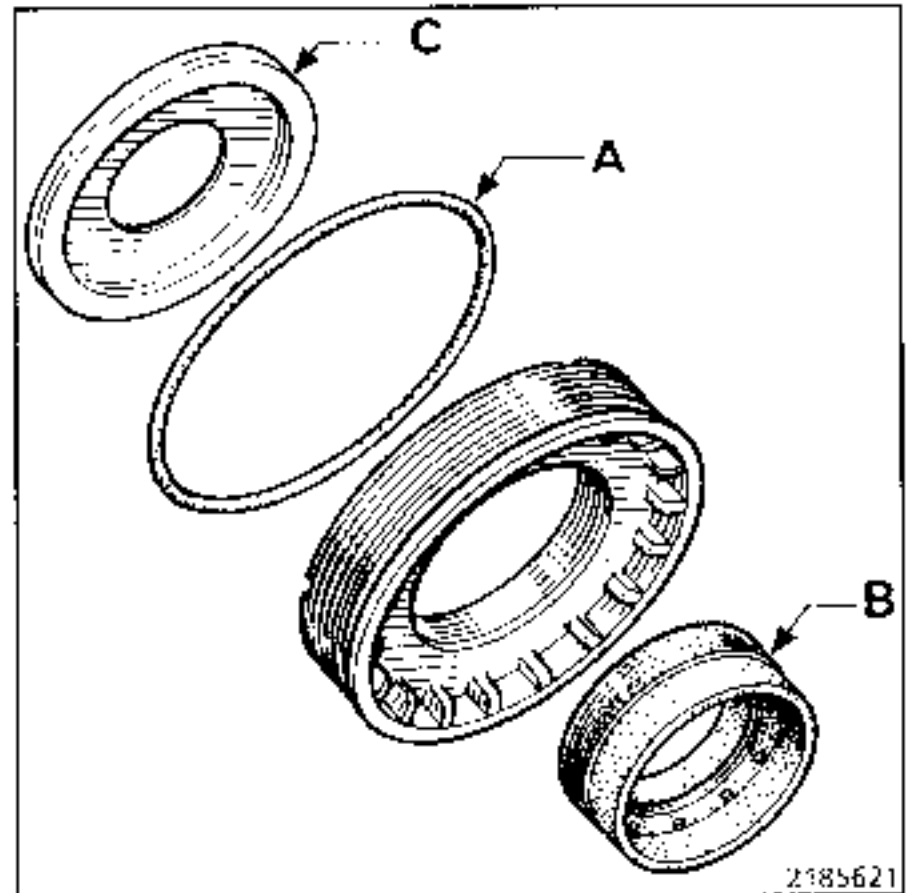

2185621

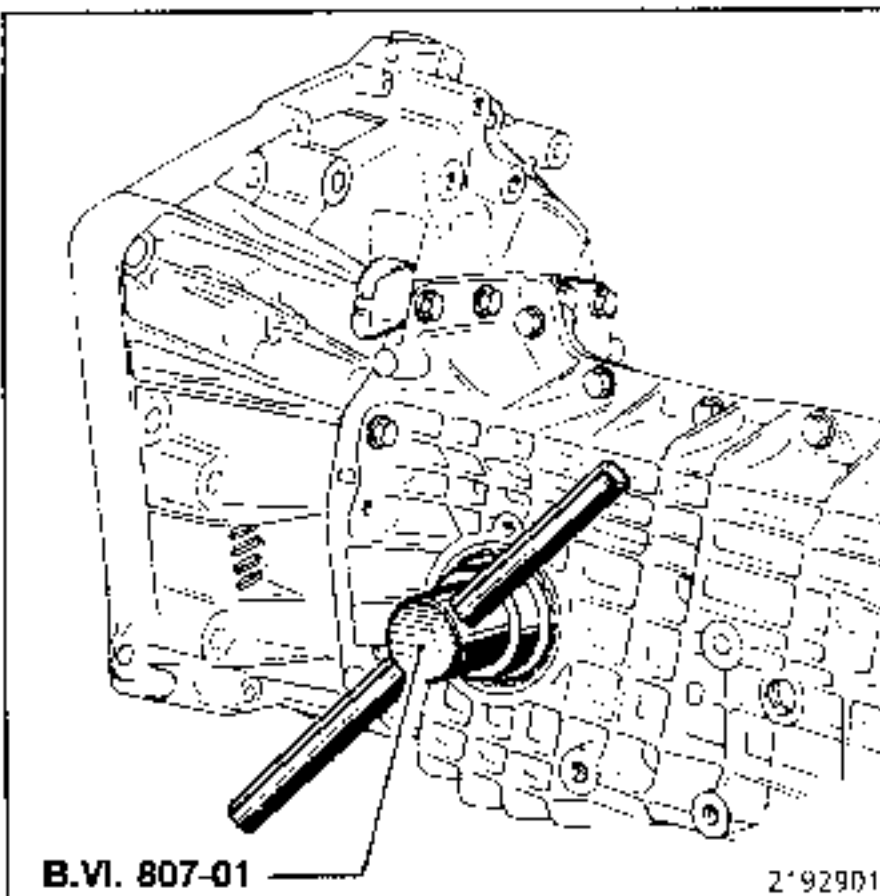

B.Vi. 807-01

2192901

REPLACEMENT (cont)**REFITTING**

Fit the deflector (C) to the nut.

The lip seal (lubricated) is fitted using tool **B.Vi. 1154** which ensures it is correctly positioned.

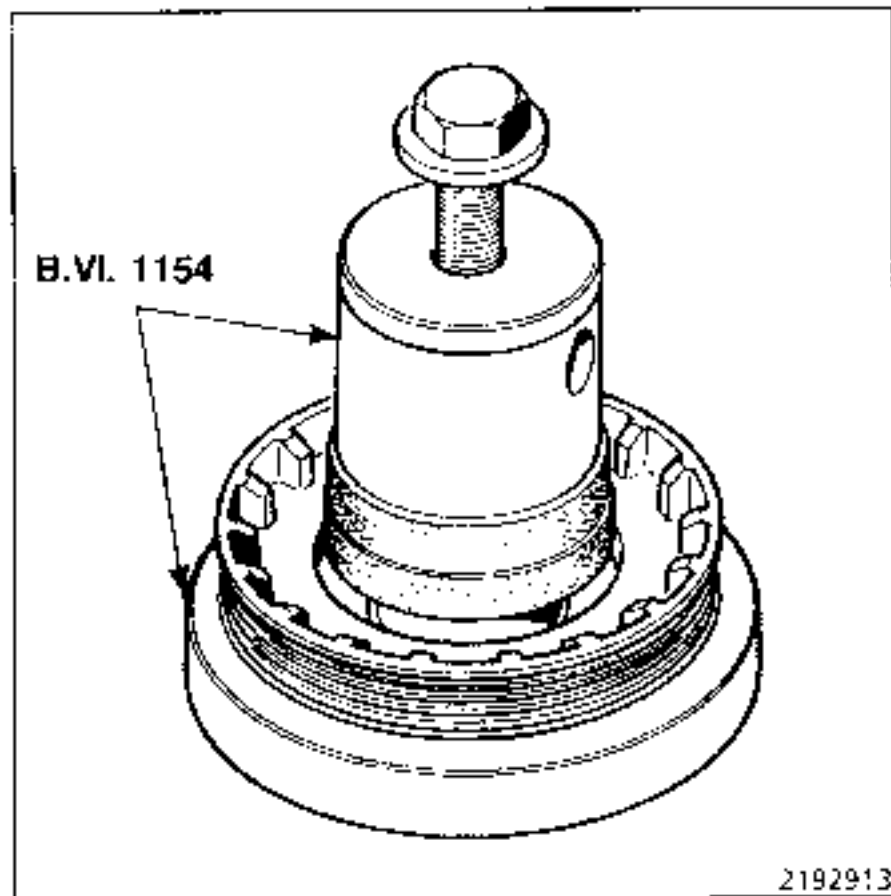

Fit the O ring (A).

Fit tool **B.Vi. 813** to the sunwheel splines.

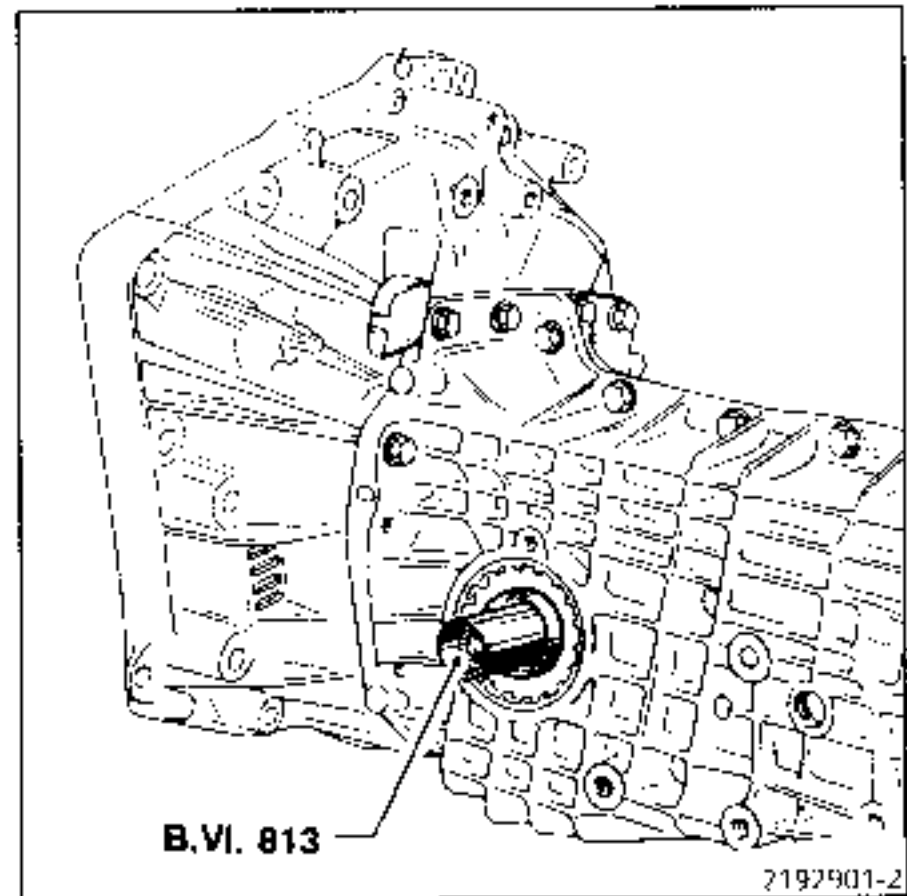

Using tool **B.Vi. 807-01**, tighten the differential nut until the reference mark on the housing is aligned.

Lock the nut using the locking plate.

Refit the O ring to the sunwheel.

Reconnect the driveshaft.

Fill the gearbox with oil.

SPECIAL TOOLING REQUIRED

B.Vi.	606	Set of punches
T.Av.	476	Ball joint extractor
B.Vi.	1081-01	Tool for fitting differential seals

TIGHTENING TORQUES (in daN.m)



Wheel bolts	9
Shock absorber base mounting nut	20
Track rod end nut	4

REMOVAL

Drain the gearbox.

Put the front of the vehicle on axle stands on the side in question.

Remove the wheel.

Remove the driveshaft roll pins (tool B.Vi. 606).

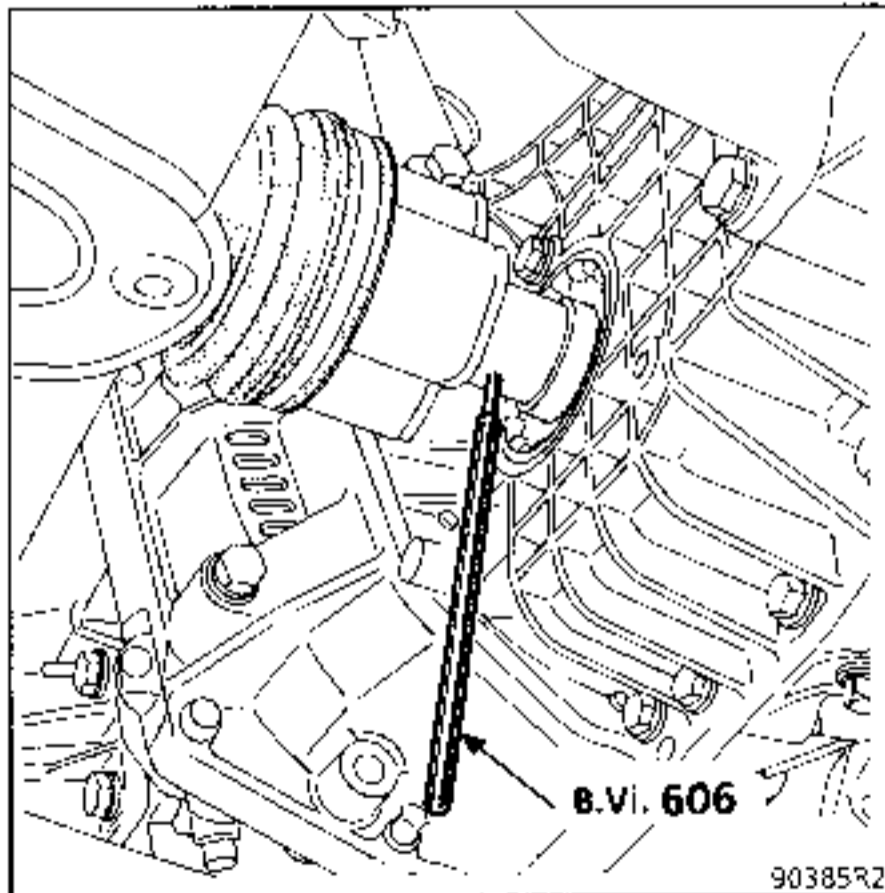

Remove the track rod end (tool T.Av. 476).

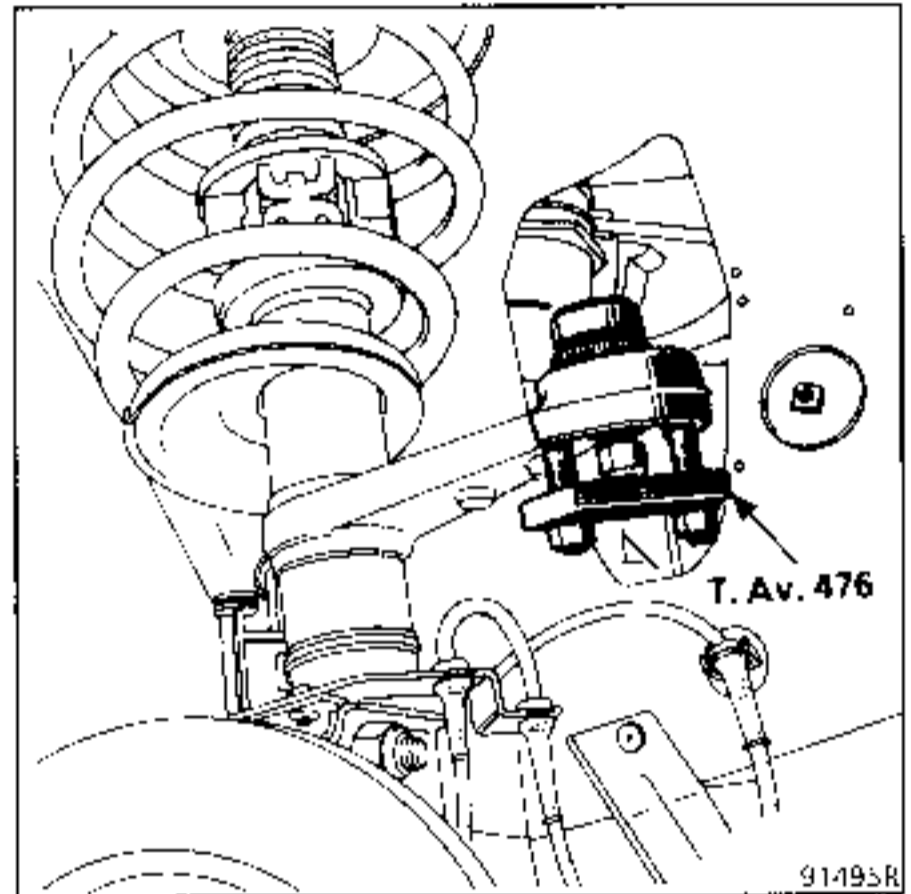

Slacken the lower shock absorber bolt (2) and remove the upper bolt (1).

NOTE : the bolts have a splined section which means that a mallet must be used to remove them.

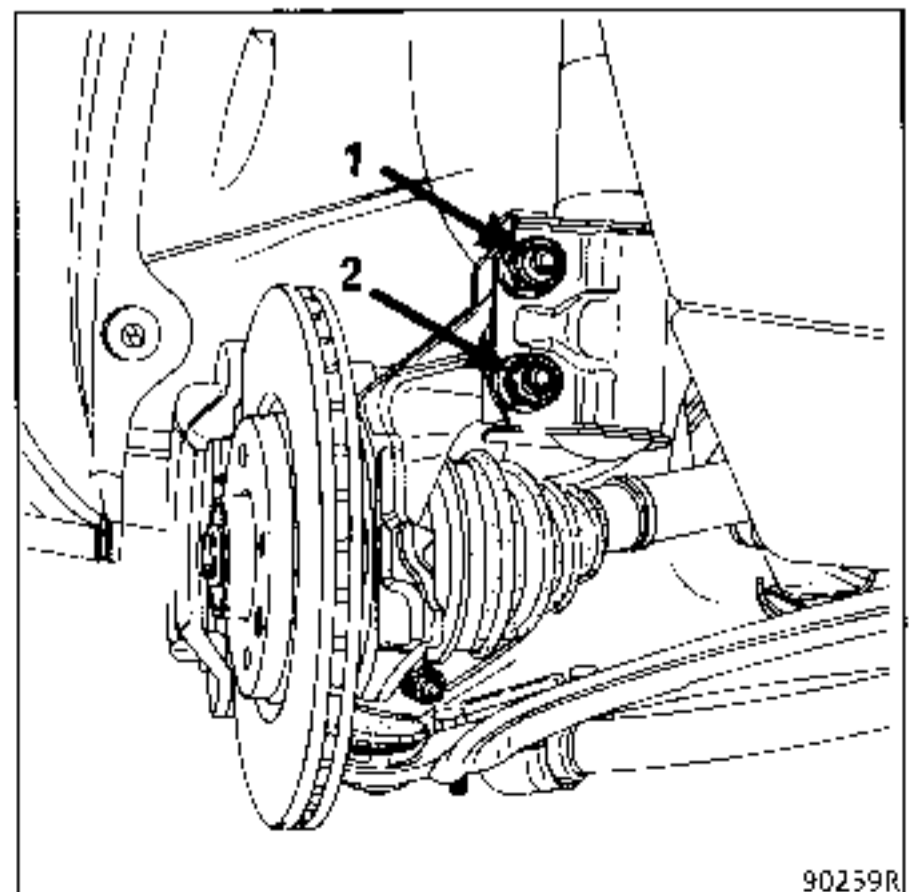

Tilt the stub axle carrier and release the driveshaft from the sunwheel.

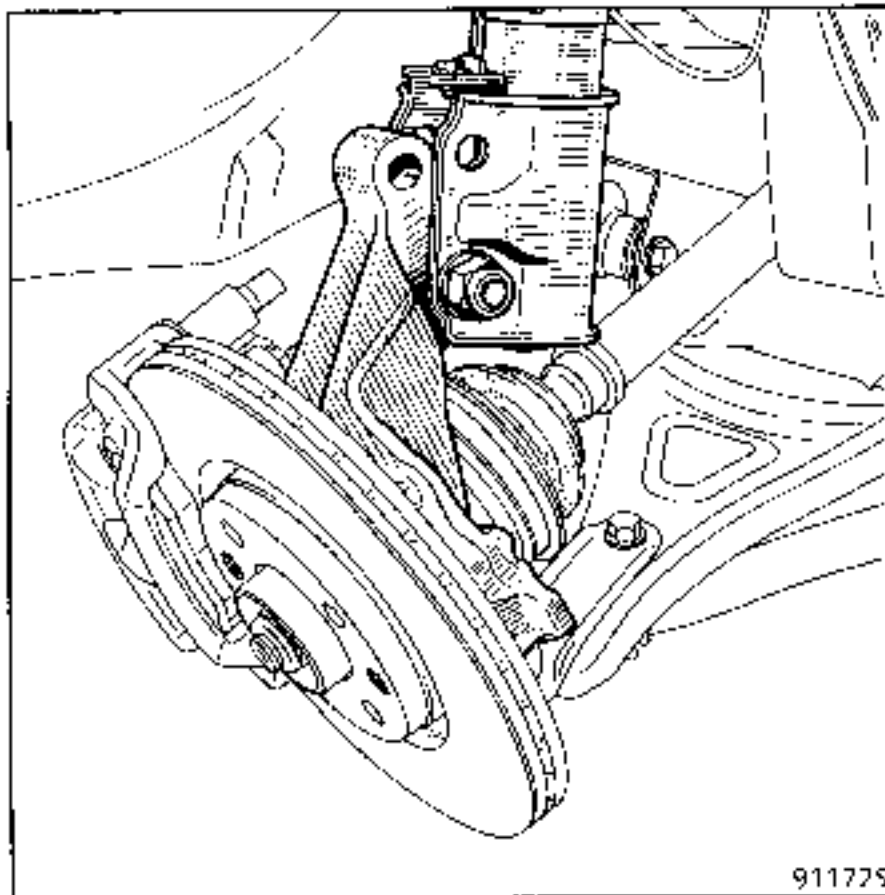

Apply adhesive tape or fit a protector (supplied with new driveshafts) to the differential output seal bearing face.

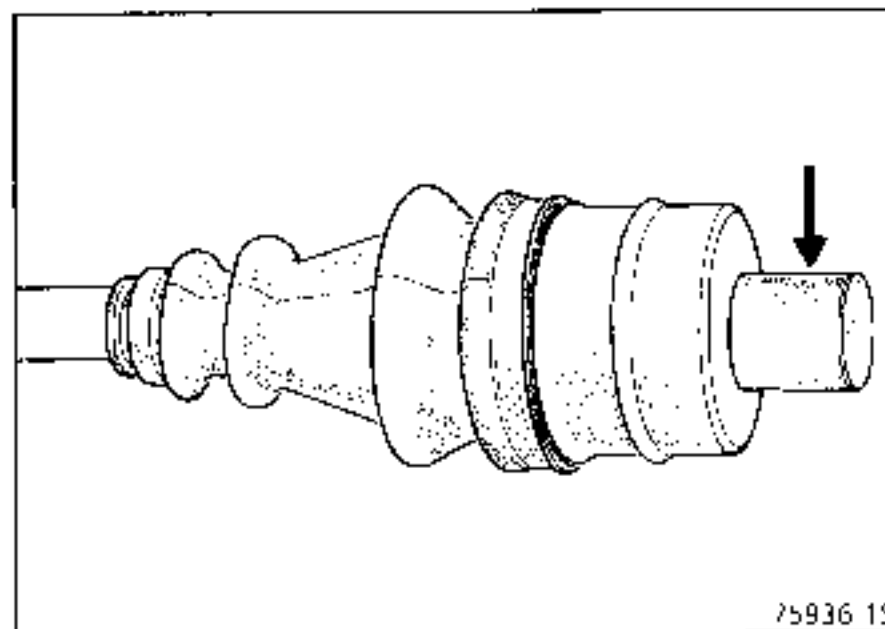

Using a roll pin punch and a small mallet, tilt the seal in its location.

Remove the seal using a screwdriver, taking care not to damage the sunwheel splines.

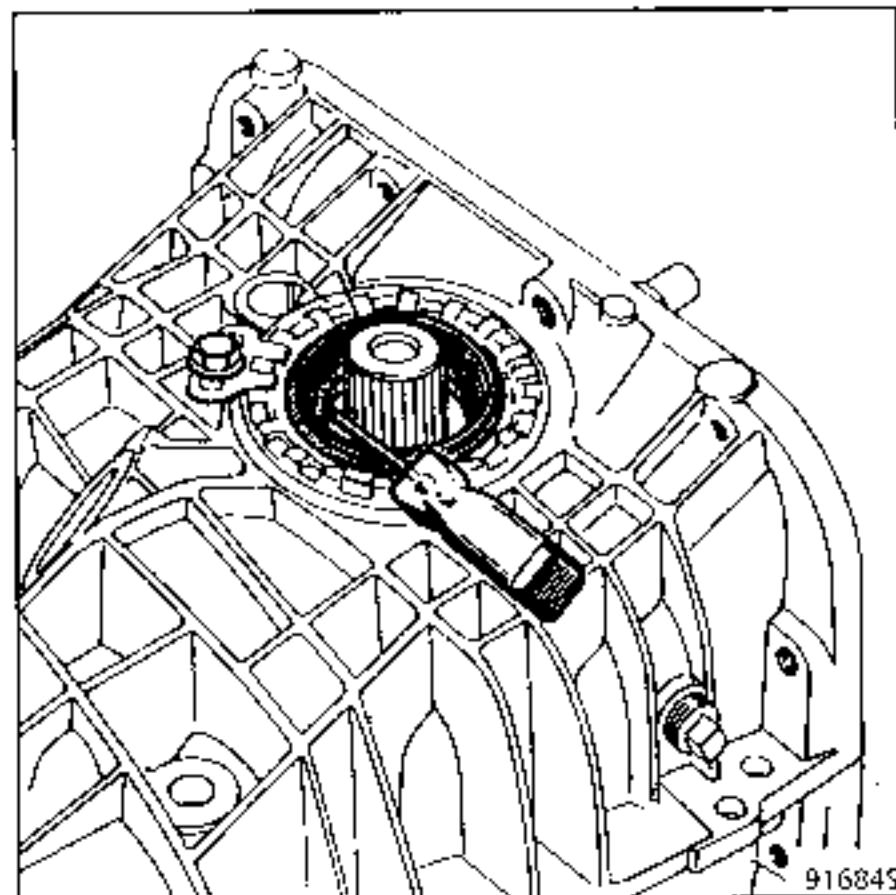

REFITTING

The lip seals are refitted using tool B.Vi. 1081-01.

Fit the locating ring (2) (corresponding to the lip seal to be fitted, chamfer towards the outside) to the sleeve (1). Fit the lubricated lip seal to tool B.Vi. 1081-01.

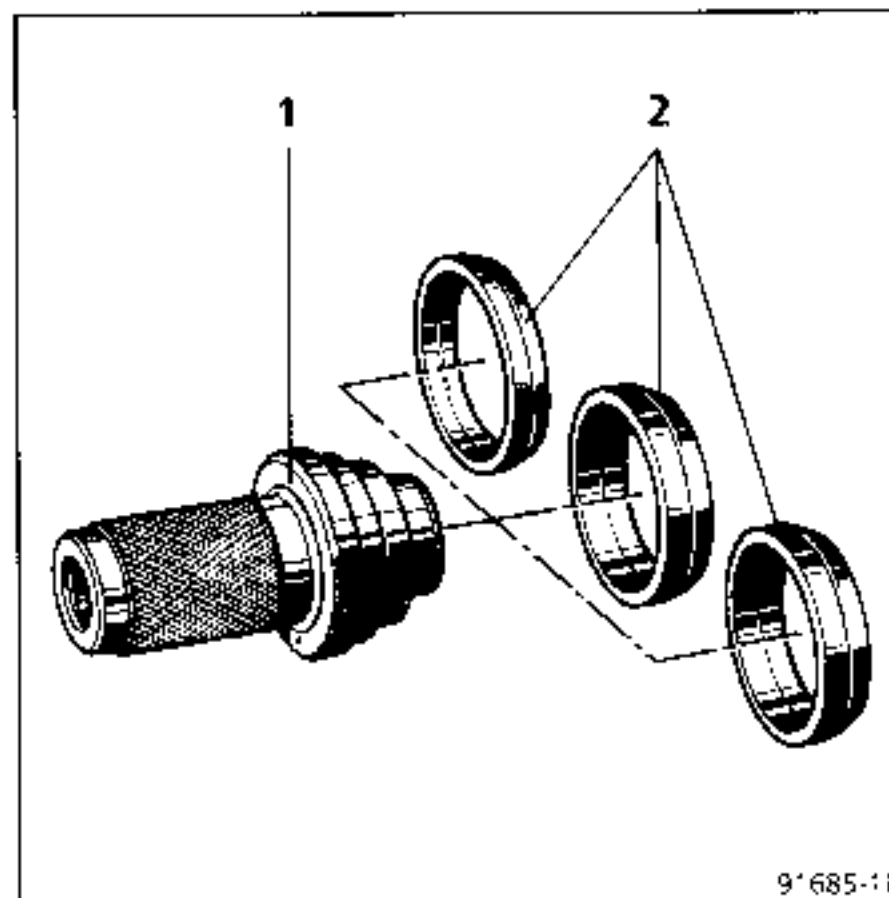

The markings I, II and III appear on the locating rings :

- Ring I : thickness 14 mm.
- Ring II : thickness 17 mm.
- Ring III : thickness 20.8 mm.

Fit the seal into position.

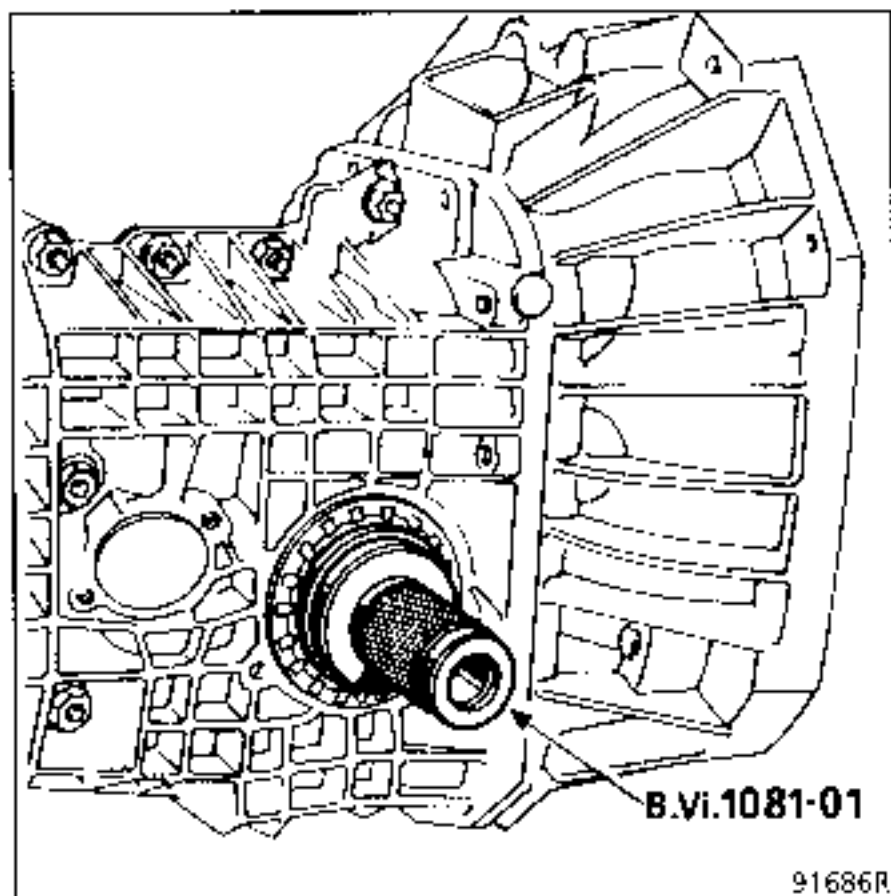

Before fitting the driveshaft, ensure the lip seal bearing face is not scratched or abnormally worn.

Coat the sunwheel splines with **MOLYKOTE BR2**.

Ensure the rubber washer is present which fits between the end of the sunwheel and the bottom of the driveshaft yoke.

Position the driveshaft in relation to the sunwheel, pivot the stub axle carriers and fit the driveshafts into the sunwheels, using tool **B.Vi. 606** to align the holes.

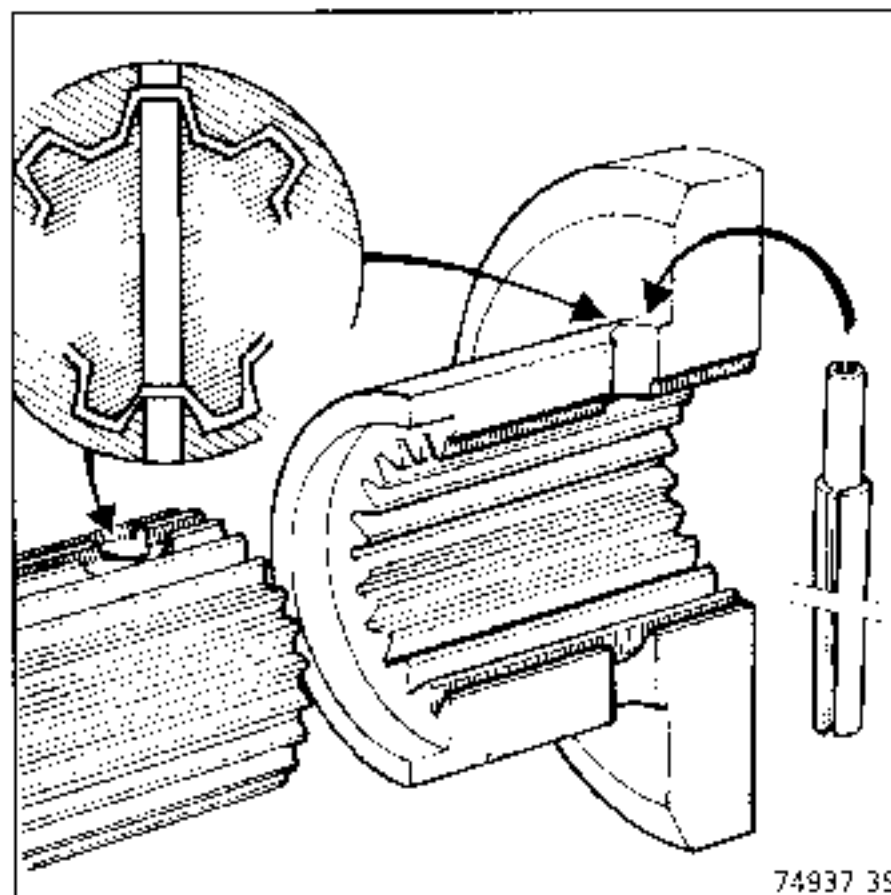

Fit the new roll pins and seal the ends (**RHODORSEAL 5661**).

Refit :

the shock absorber base bolts to the stub axle carrier and tighten them to the correct torque,

- the track rod end, then torque tighten it.

Fill the gearbox with oil.

Torque tighten the wheel bolts.

REPLACEMENT**1ST CASE**

Only the speedo drive or shaft is **damaged**.

REMOVAL

The gearbox does not need to be completely dismantled.

Release the left hand driveshaft

Remove the sunwheel spider.

Turn the differential by hand so that the speedo pinion is accessible.

Release the shaft, pulling vertically using long nosed pliers.

Use these pliers to remove the pinion from its location.

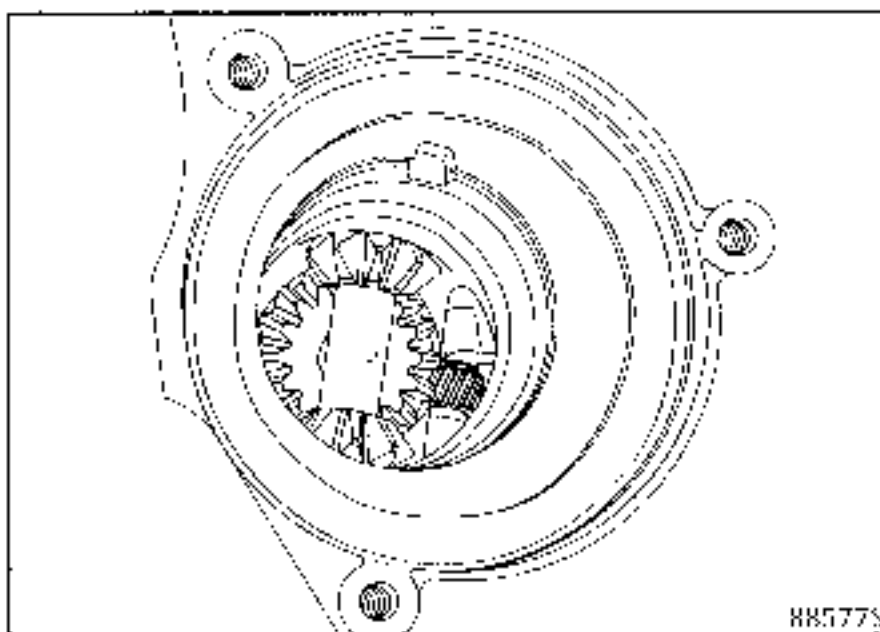

NOTE : The pinion and shaft must be renewed each time they are removed.

REFITTING

Fit the pinion, ensuring it is correctly located, the correct way round.

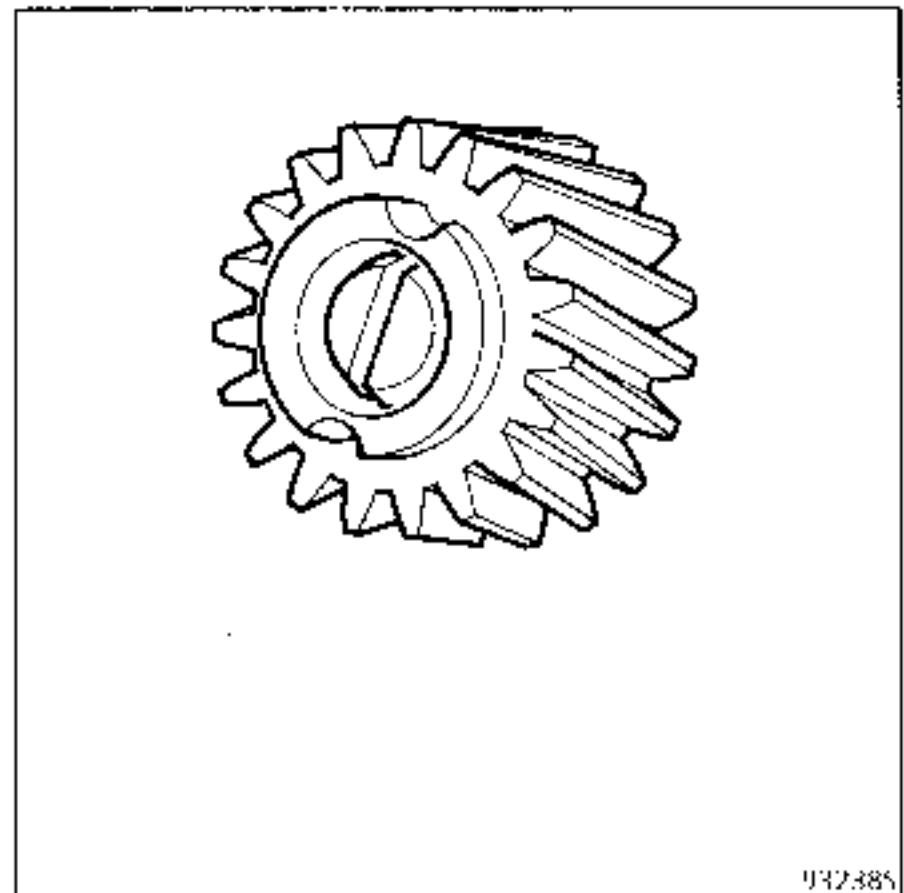

Ensure that it is correctly clipped in.

Refit the sunwheel spider.

2ND CASE

The speedo drive pinion and crown wheel are **damaged**.

The gearbox must be removed and the final drive dismantled.

SPECIAL TOOLING REQUIRED

B.Vi.	204-01	Wrench for secondary shaft nut
B.Vi.	905-02	Speedo shaft seal fitting and removal tool

TIGHTENING TORQUES (in daN.m)



Primary shaft nut	13
Secondary shaft nut	15
Rear housing bolt	1.6 to 2

It is not possible to replace the 5th speed gear linkage on the vehicle as it is essential not to remove the 5th gear fork shaft (A), as the locking ball (B) may fall into the gearbox.

This section however deals with the removal of the 5th gear housing on the vehicle for an operation on this part or replacement of the speedo drive.

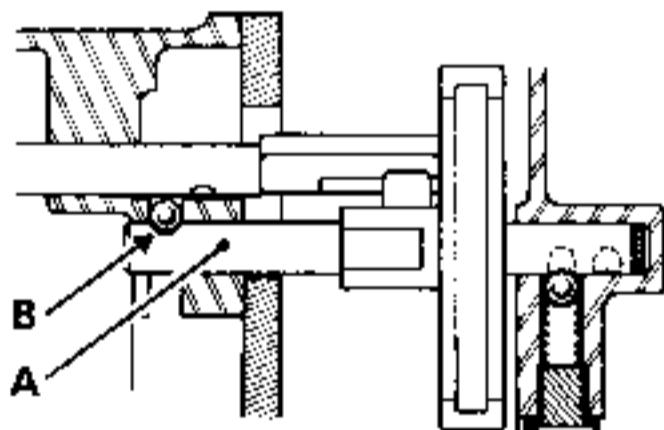

90620R

REMOVAL

Drain the gearbox.

Remove:

- the selector controls:
 - at (A) the two mounting bolts,
 - at (B) release the ball joint,
- the reverse gear locking mechanism (V),
- the 5th gear locking ball.

Disconnect the speedo cable after removing the plastic roll pin.

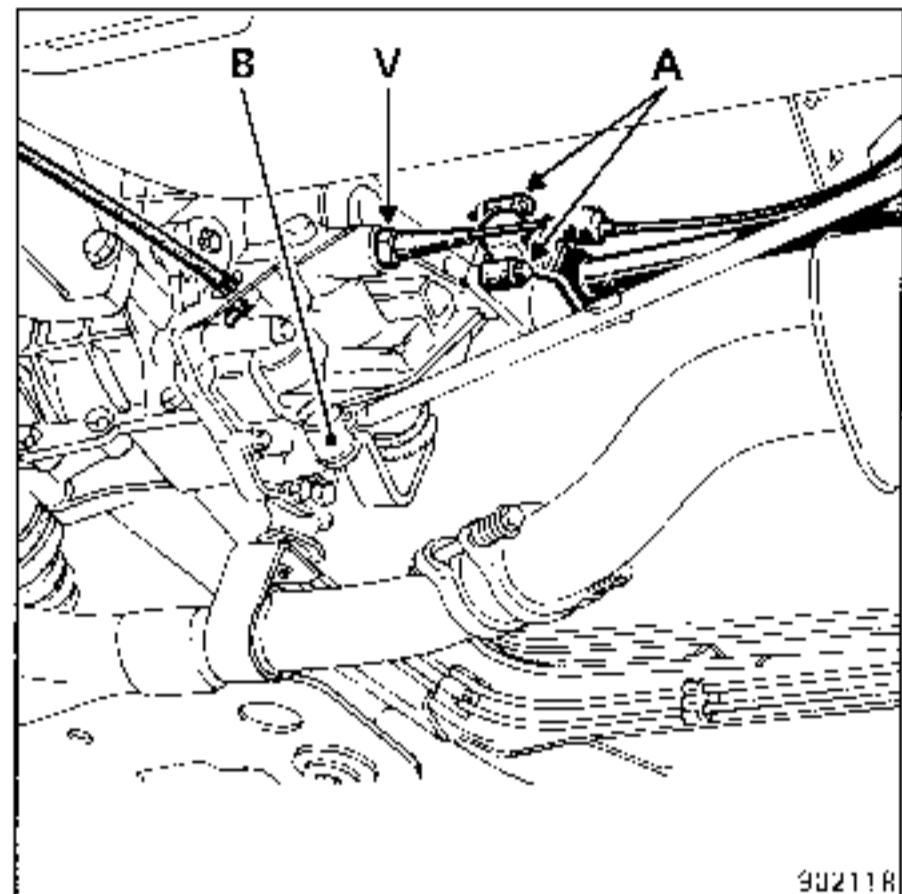

90211R

Select 4th gear so the 5th gear locking ball does not fall into the gearbox.

Remove the 5th gear housing.

Replacing the secondary shaft nut:

- return the gearbox to neutral, select 1st and 5th,
- replace the secondary shaft nut (1) using wrench B.Vi. 204-01 and a torque wrench.

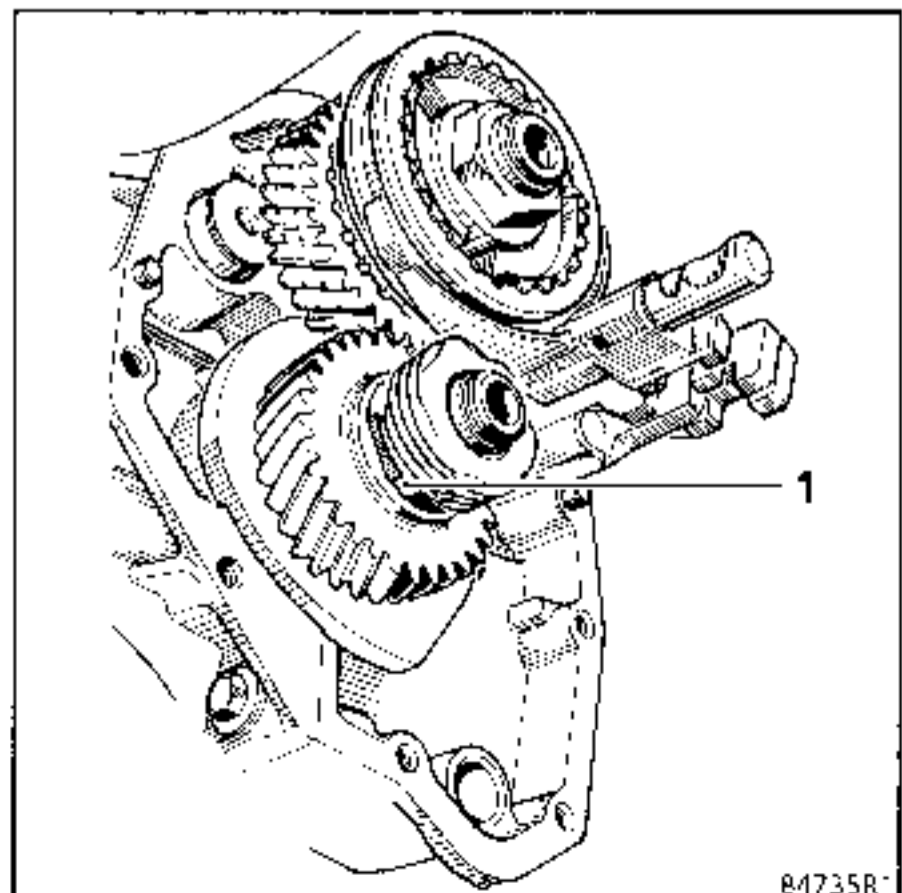

84735R

Separate catches (C) mounting the pinion to the shaft. Pull on the speedo shaft.

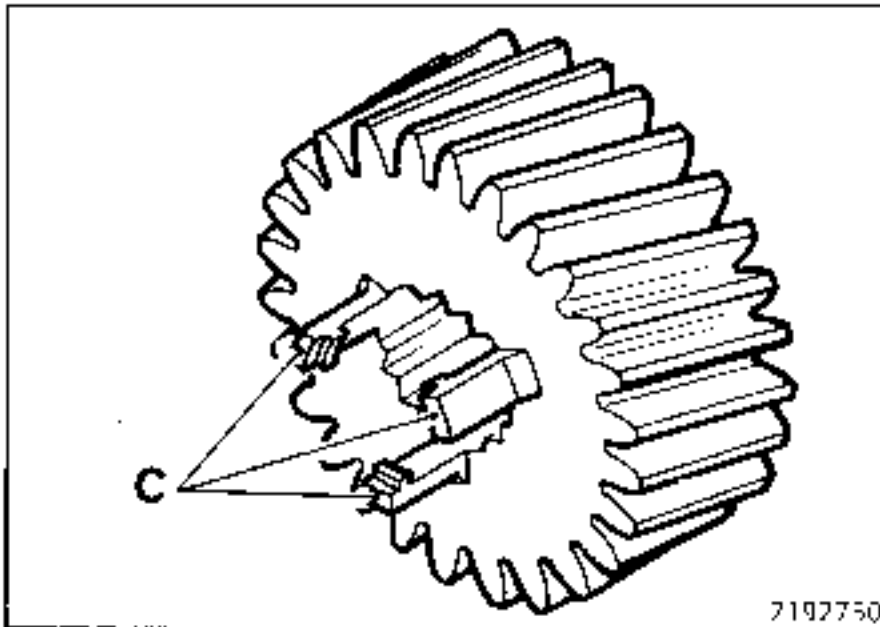

NOTE : the pinion must be renewed after each removal.

Remove:

- the speedo seal, use tool **B.Vi. 905-02**.

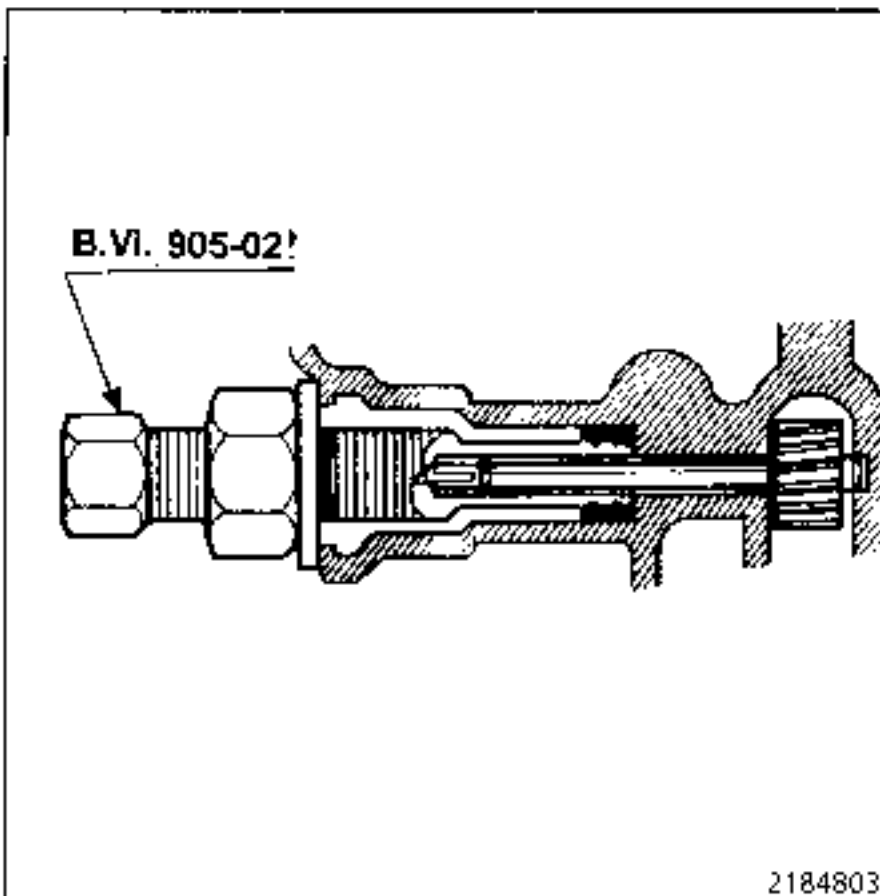

REFITTING

Fit the lubricated lip seal to the tool of **B.Vi. 905-02** ensuring it is the correct way round.

Refit:

- the speedo shaft seal,

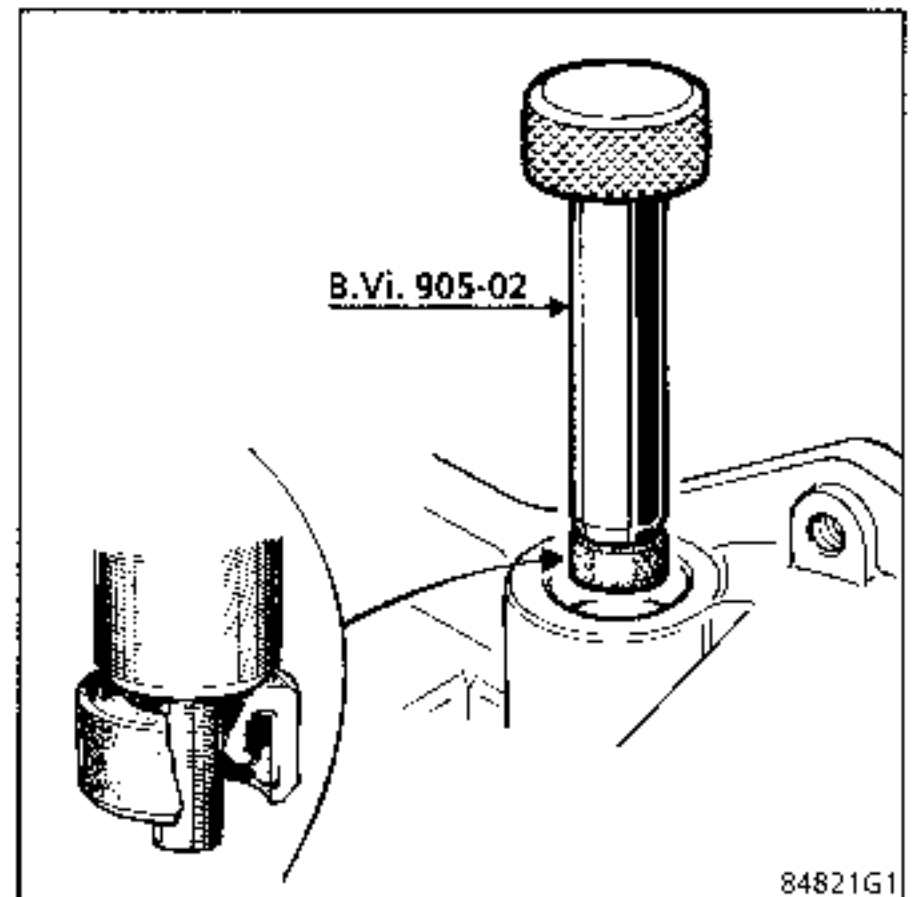

- the speedo pinion and shaft.

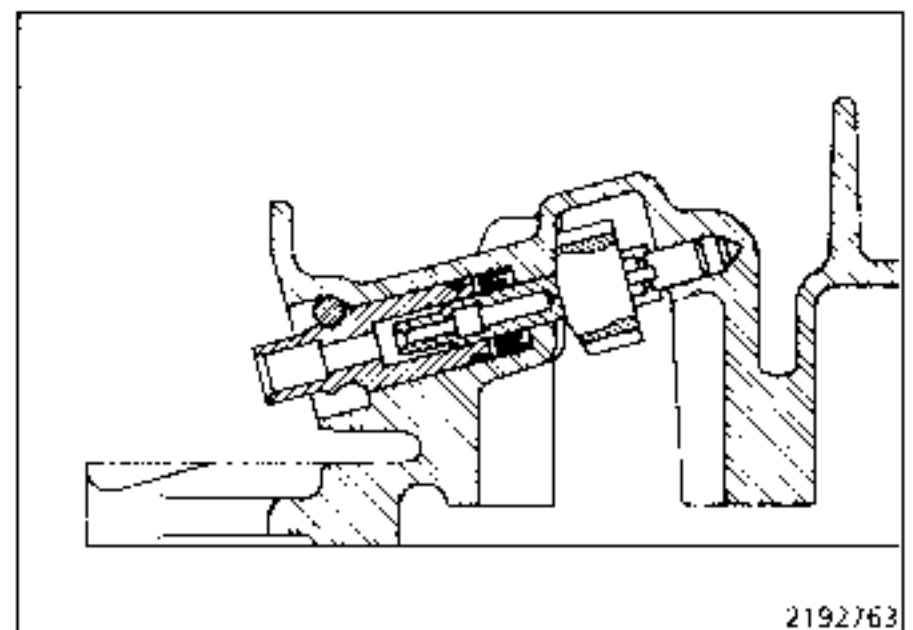

Check that the pinion mounting catches clip into the groove on the shaft.

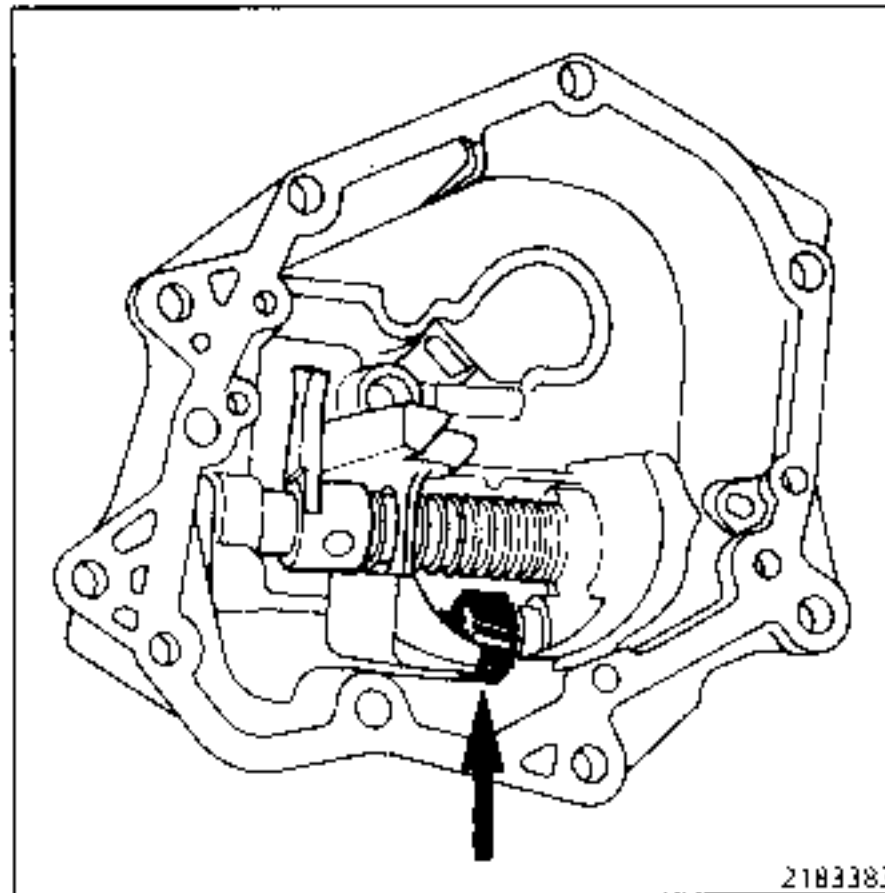

Return the gearbox to neutral, select 4th gear then fit the housing into position (paper seal coated with **PERFECT SEAL**).

Tighten the bolts to the recommended torque.

Check that all the gears can be selected.

Use **RHODORSEAL 5661** to coat the threads of the 5th gear locking ball plug and the reverse gear positive locking mechanism.

Fill the gearbox with oil.

REPLACEMENT**1ST CASE**

Only the speedo drive or shaft is damaged.

REMOVAL

The gearbox does not need to be completely dismantled.

Remove the two mounting bolts for the locking plate and take out the guide, shaft and speedo pinion assembly.

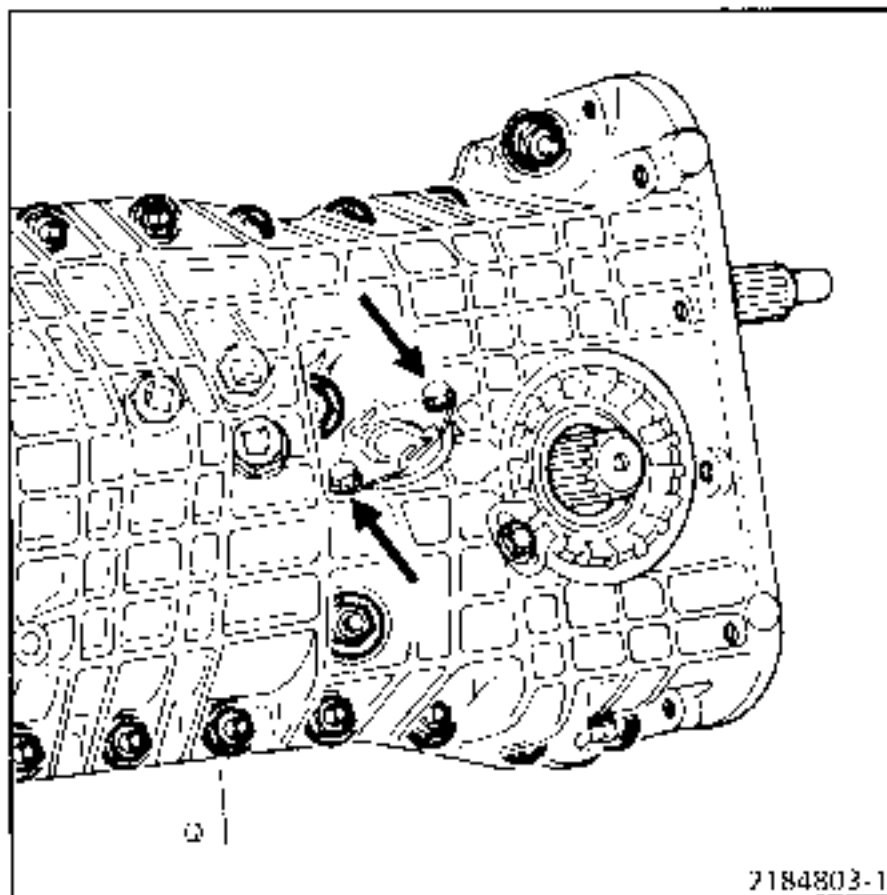
**REFITTING**

Refit the pinion, shaft and guide assembly with a new, lubricated O ring.

2ND CASE

The speedo pinion and crown wheel are damaged.

The gearbox must be removed and the half-housings separated.

On the differential housing, unclip the circlip securing the speedo crown wheel and remove it.

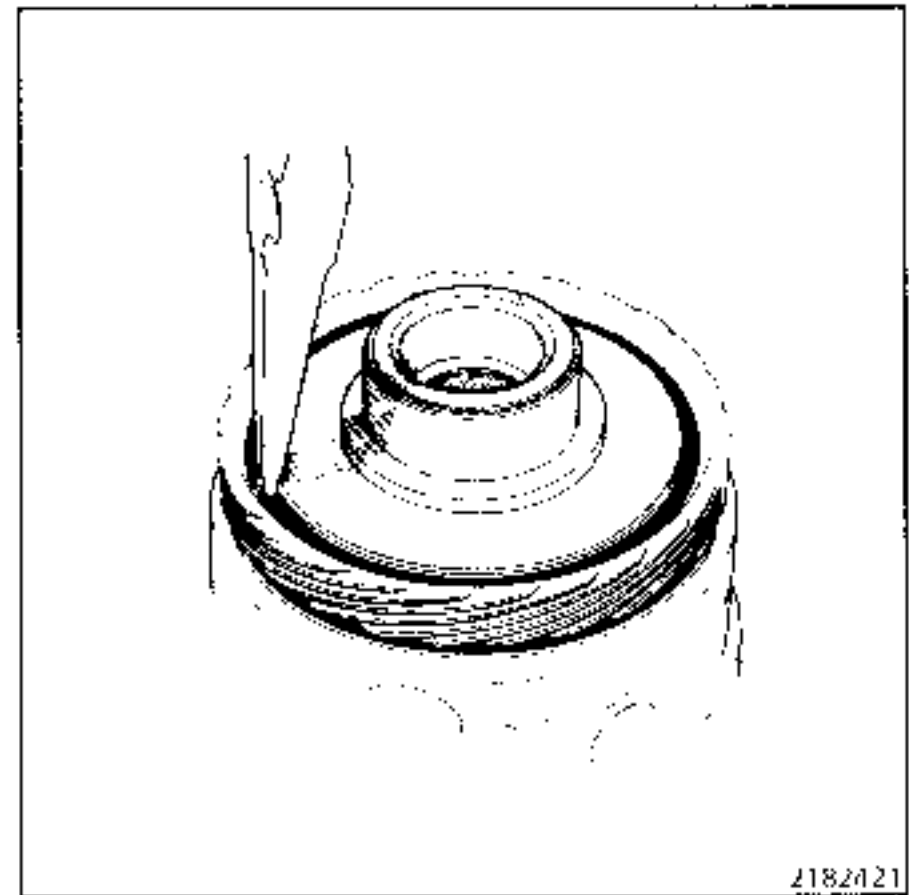

There are no special notes for refitting.

REMOVAL - REFITTING

TIGHTENING TORQUES (in daN.m) 	
Rear housing mounting bolt	2.5
Gearbox output flange bolt	2.5
Bearing mounting bolt	2.5

REMOVAL

Drain the gearbox.

Remove the expansion chamber.

Depolluted vehicles

Disconnect the connector (2) for the oxygen sensor (1).

Remove the catalytic converter.

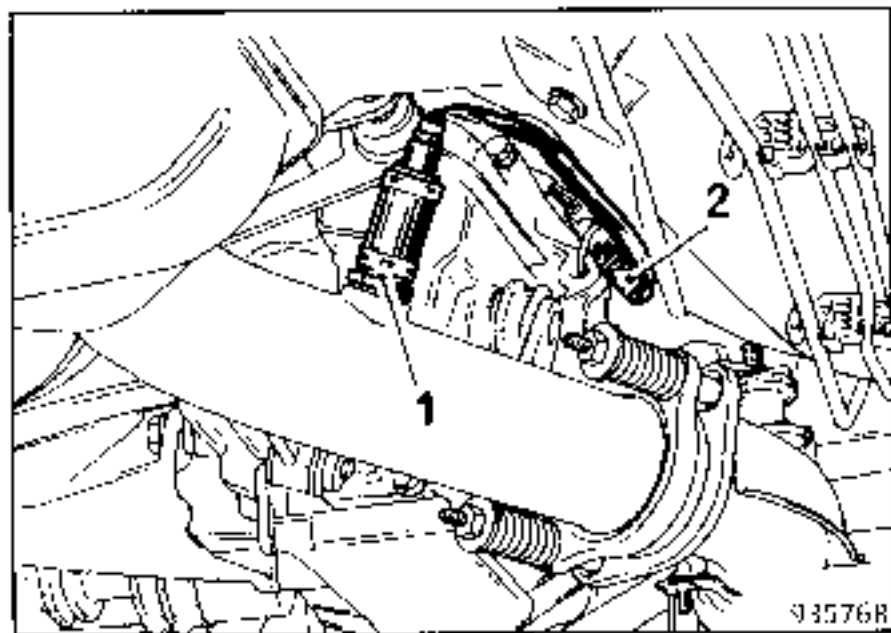

NOTE : the catalytic converter should not be subjected to impacts, which may damage it if repeated.

Remove the rear cover mounting bolts (leaving one partially screwed in to retain the assembly).

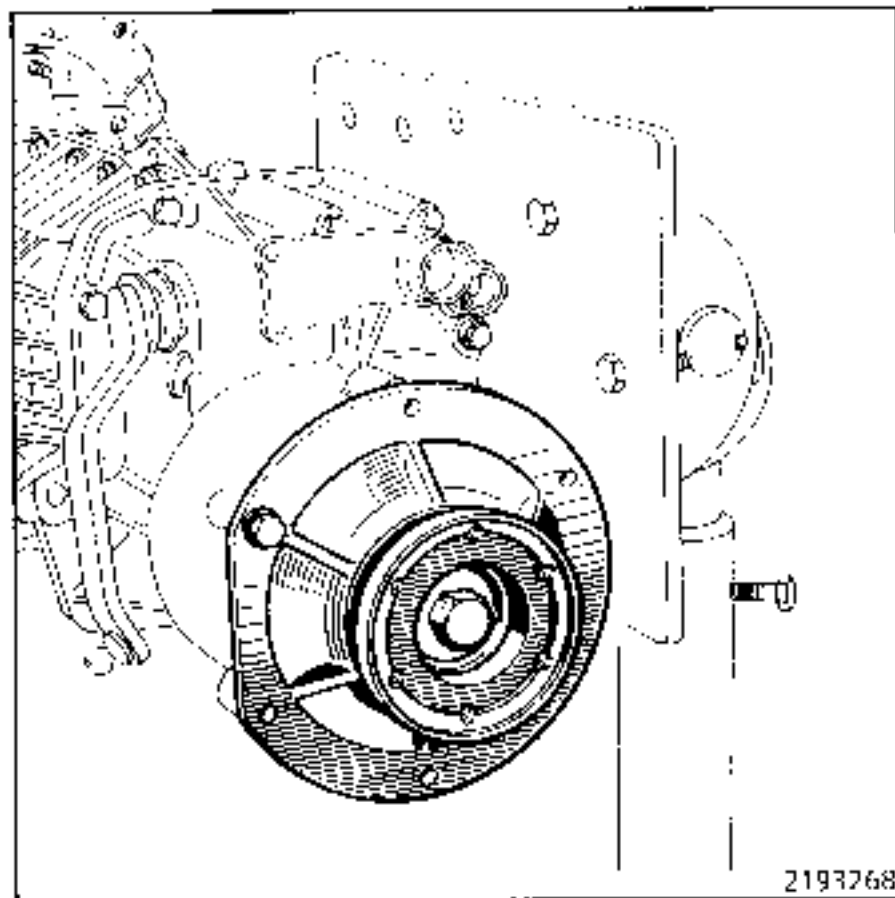

Release and remove the cover - flange - visco coupling assembly.

If necessary, remove the planet wheel carrier using tool T.Ar. 1094.

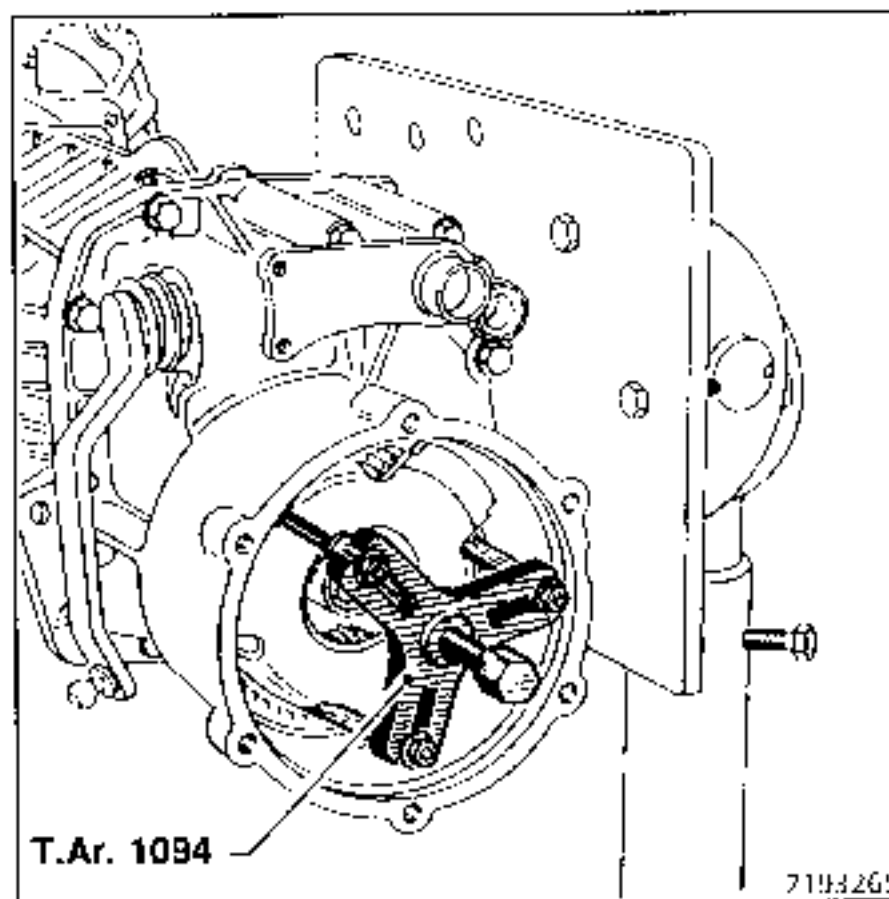

REMOVAL - REFITTING (cont)

Check the condition of the parts :

- the planet wheel teeth should have no gaps, traces of seizing or abnormal wear.
ensure the planet wheels turn freely, without excessive play on their shafts.

REFITTING

Renew the rear cover O ring systematically.
Fit the planet wheel carrier into the inlet bellhousing.

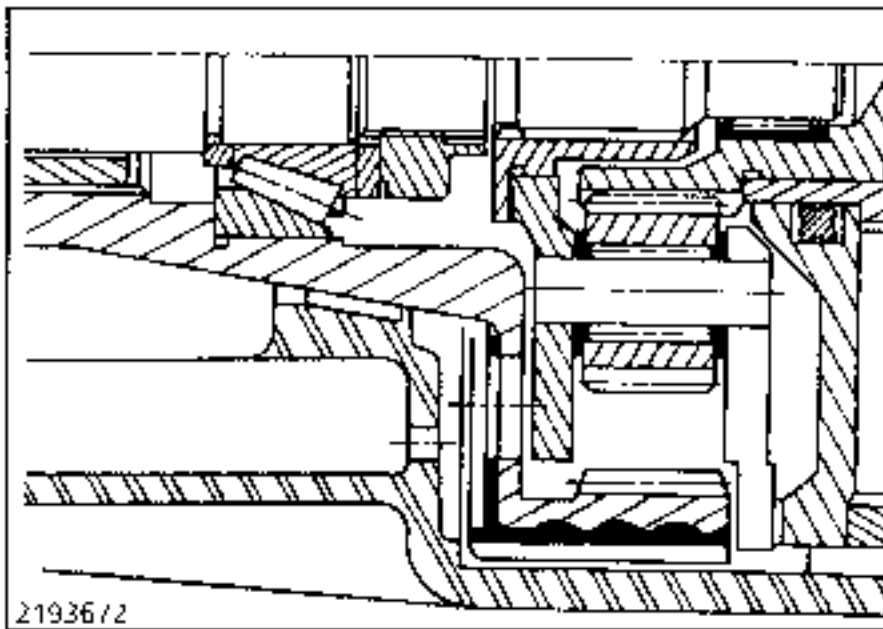

Turning the flange, and without forcing it, fit the cover - flange - visco coupling assembly.

Check the position of:

- the planet wheel carrier in the visco coupling notches,

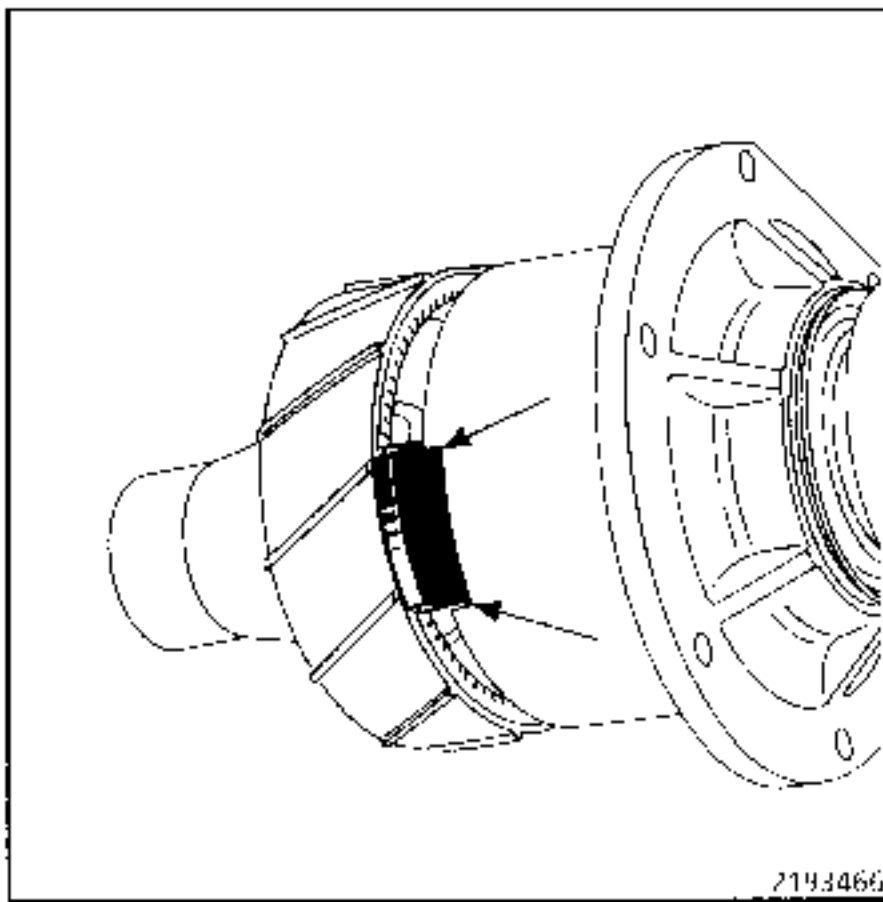

- the rear cover on the intermediate housing: one of the mountings is offset to align the bearing and seal lubrication openings,

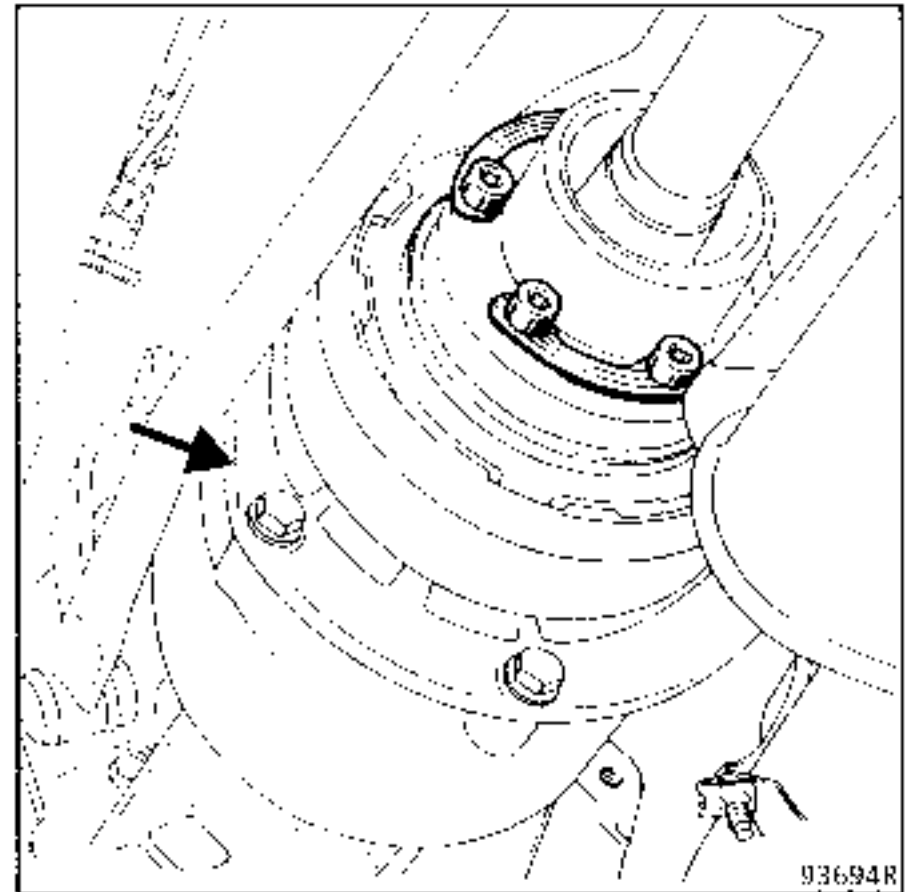

- the O ring.

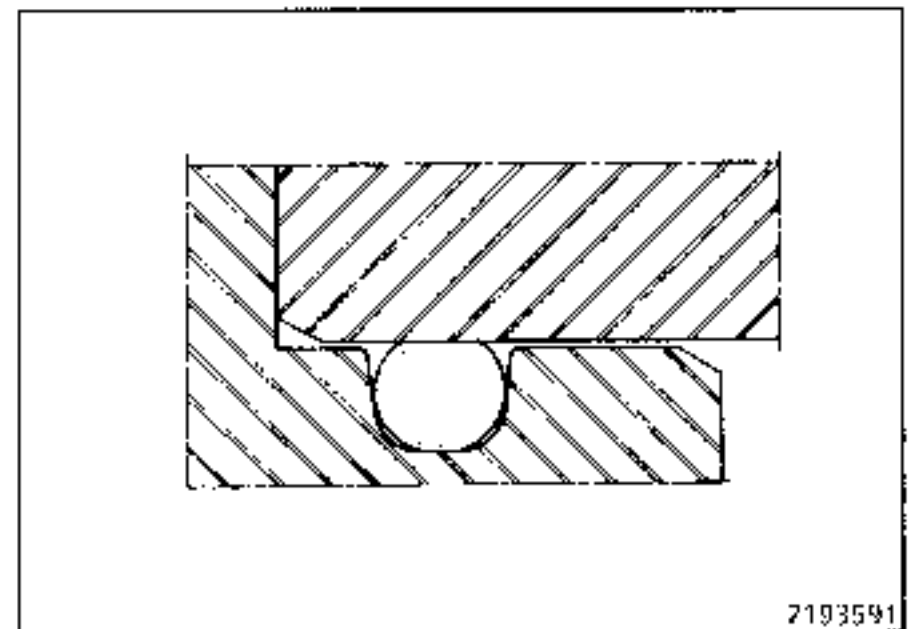

Refit the expansion chamber or catalytic converter (depending on version).

Depolluted vehicles

Reconnect the connector (2) for the oxygen sensor (1) and ensure the connection is correct.

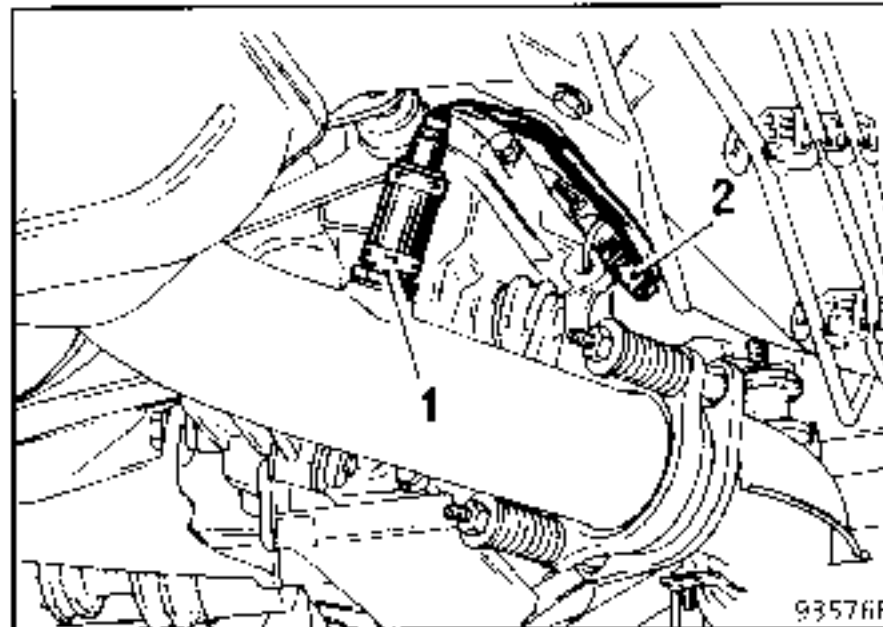

IMPORTANT:

- the oxygen sensor wires cannot be spliced or soldered; if the wires are broken, the oxygen sensor must be replaced,
- sealing from the exhaust manifold sealing face to the catalytic converter must be perfect,
- all seals which are removed **MUST** be renewed.



Tighten all nuts and bolts to the recommended torque.

Fill the gearbox with oil.

REPLACEMENT

This operation is carried out after removing the rear cover - visco coupling - flange assembly.

SPECIAL TOOLING REQUIRED		
B.Vi.	1078	Tool for fitting sensor ring spring
B.Vi.	1106	Tool for fitting bearing
B.Vi.	1185	Tool for fitting O ring
Rou.	604-01	Hub locking tool

TIGHTENING TORQUES (in daN.m) 	
Output flange mounting bolt	7 to 8

Remove the blanking cover.

Fit tool **Rou. 604-01** to the flange and remove the flange mounting bolt.

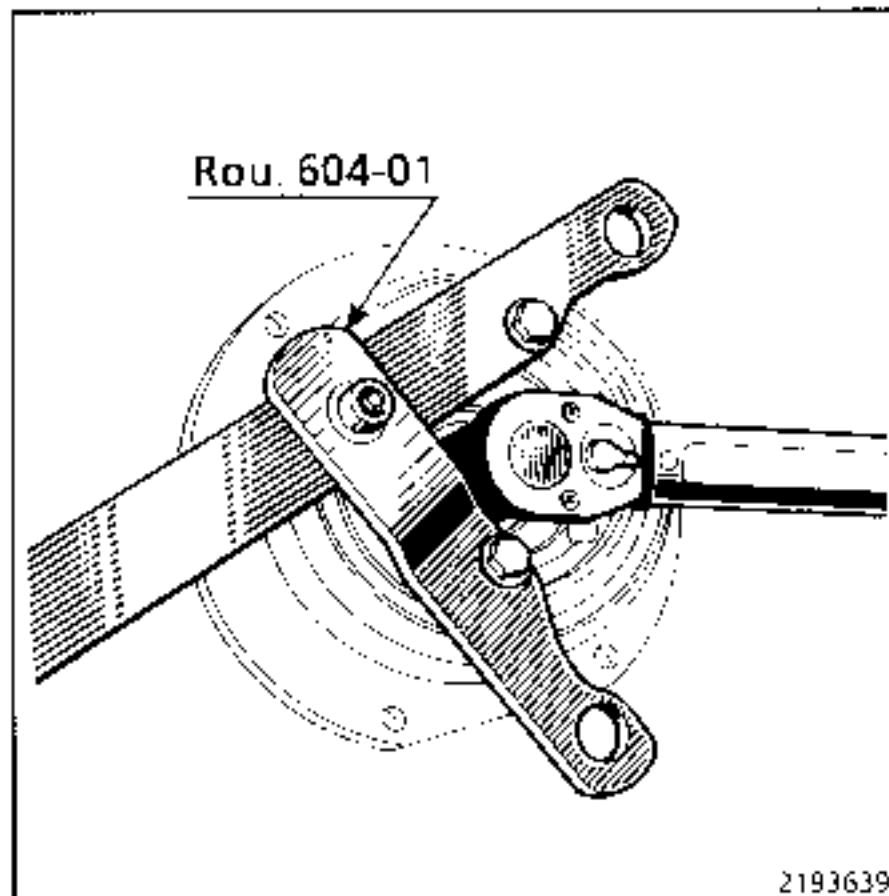

NOTE : the bolt must be renewed each time it is removed.

Take the weight on the rear cover and remove the output shaft - visco coupler assembly on the press.

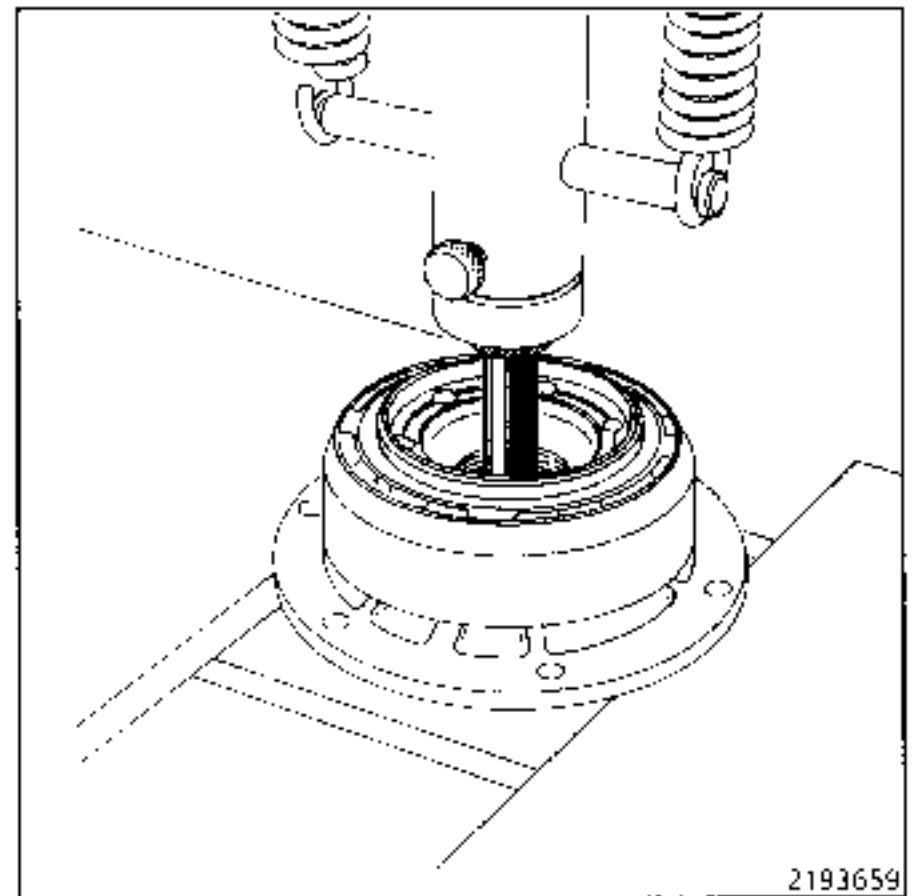

REPLACEMENT

Remove the flange and bearing mounting circlips.

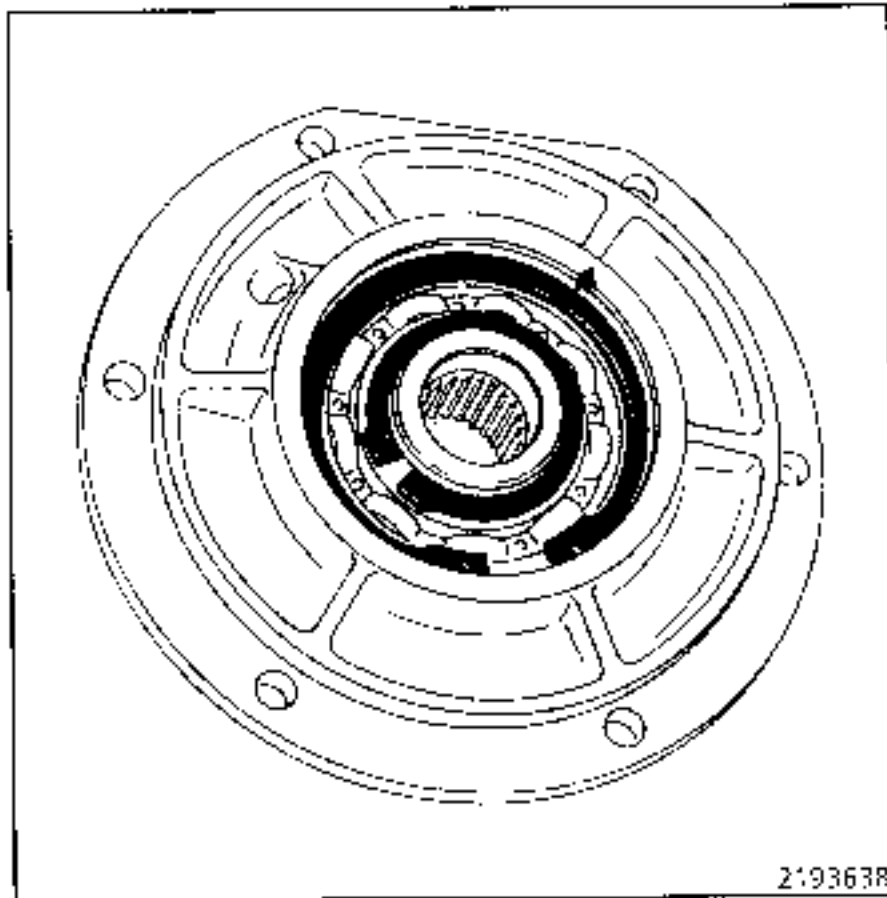

Take the weight on the cover and remove the flange on the press.

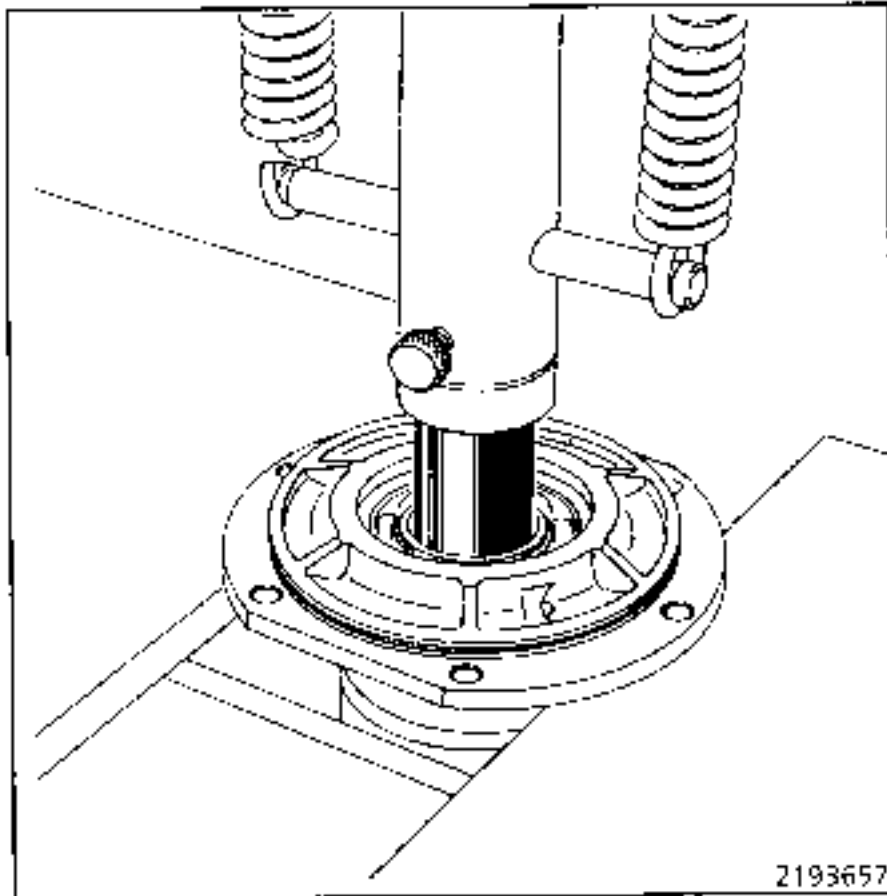

NOTE: the bearing has to be renewed systematically when removing the flange.

Remove the lip seal and remove the bearing using tool B.Vi. 1078.

REFITTING - Special notes

Ensure the seal bearing face on the flange is free from all scratches or traces of abnormal wear.

The Parts Department supplies the flange with the **DAMPER** (vibration damper) assembled.

Fit the bearing taking the weight on the external ring using tool B.Vi. 1106.

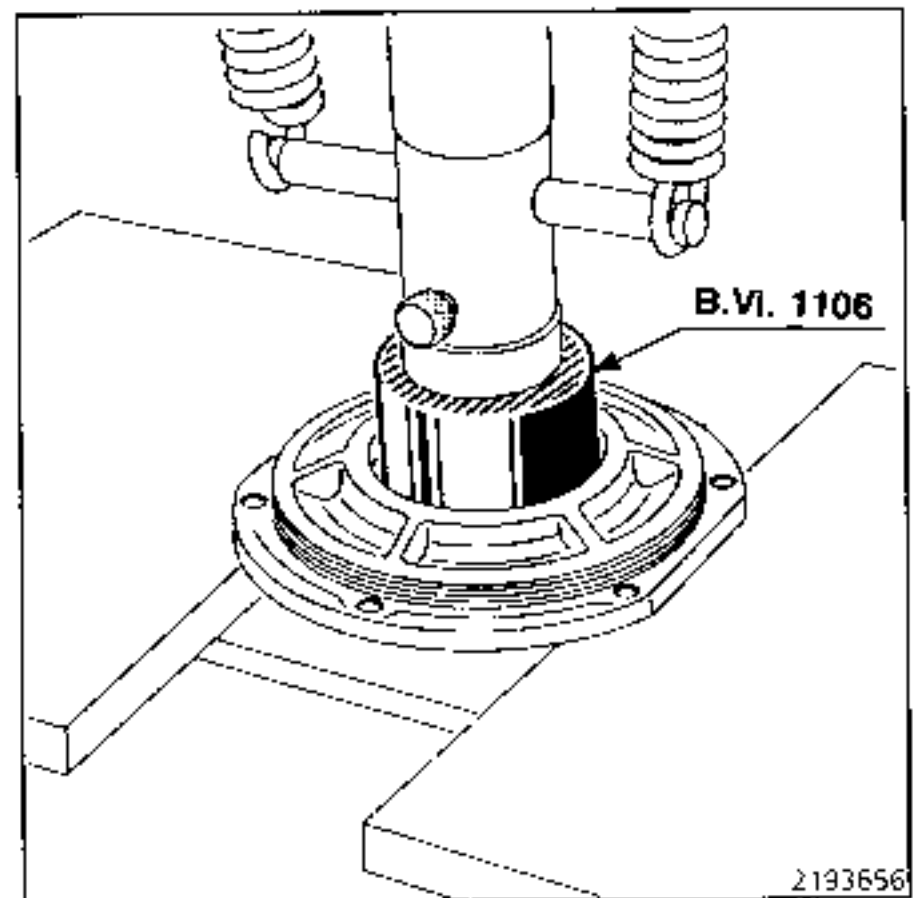

Fit the bearing retaining circlip.

REPLACEMENT

Fit the lip seal (lubricated).

Fit the flange on the press using tools **B.Vi. 1106** and **1078** so that the weight may be taken on the inner bearing ring.

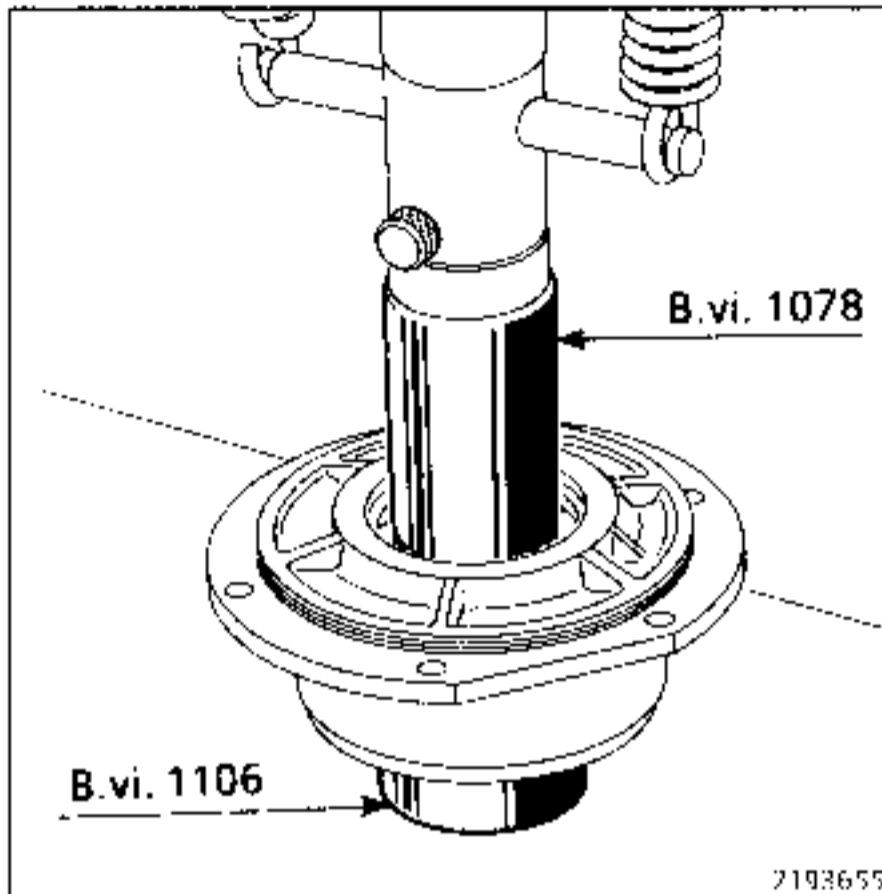

Replace the O ring on the output shaft using tool **B.Vi. 1185**.

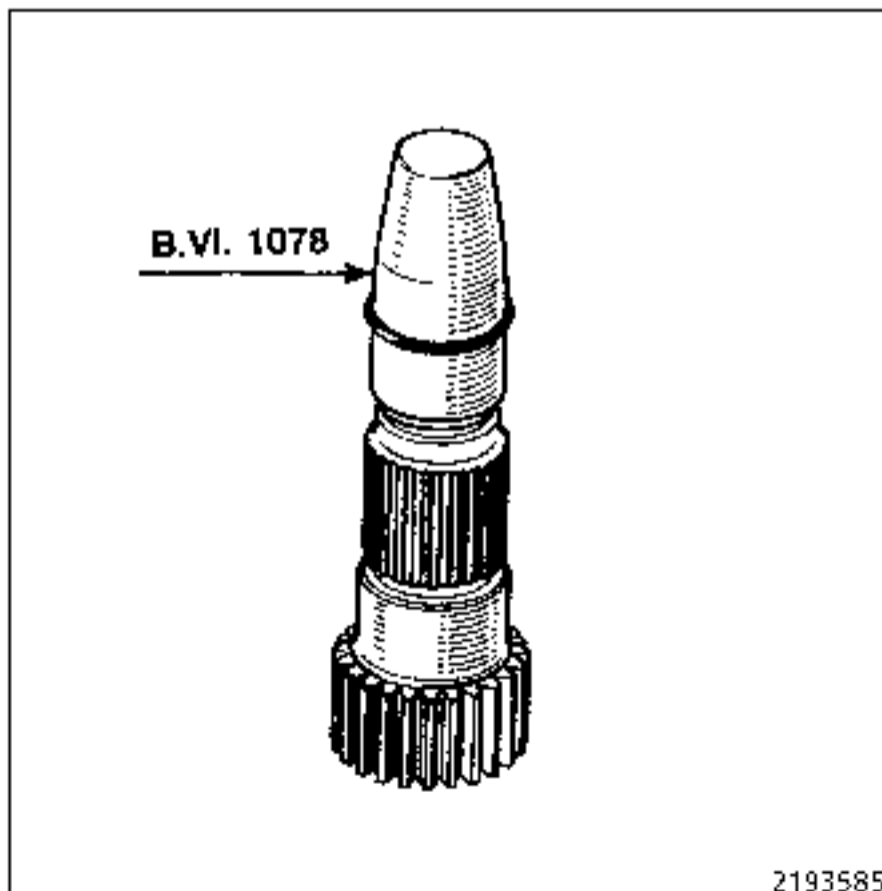

Fit the output shaft - visco coupling assembly and fit the output flange - rear cover assembly on the press using tool **B.Vi. 1106**.

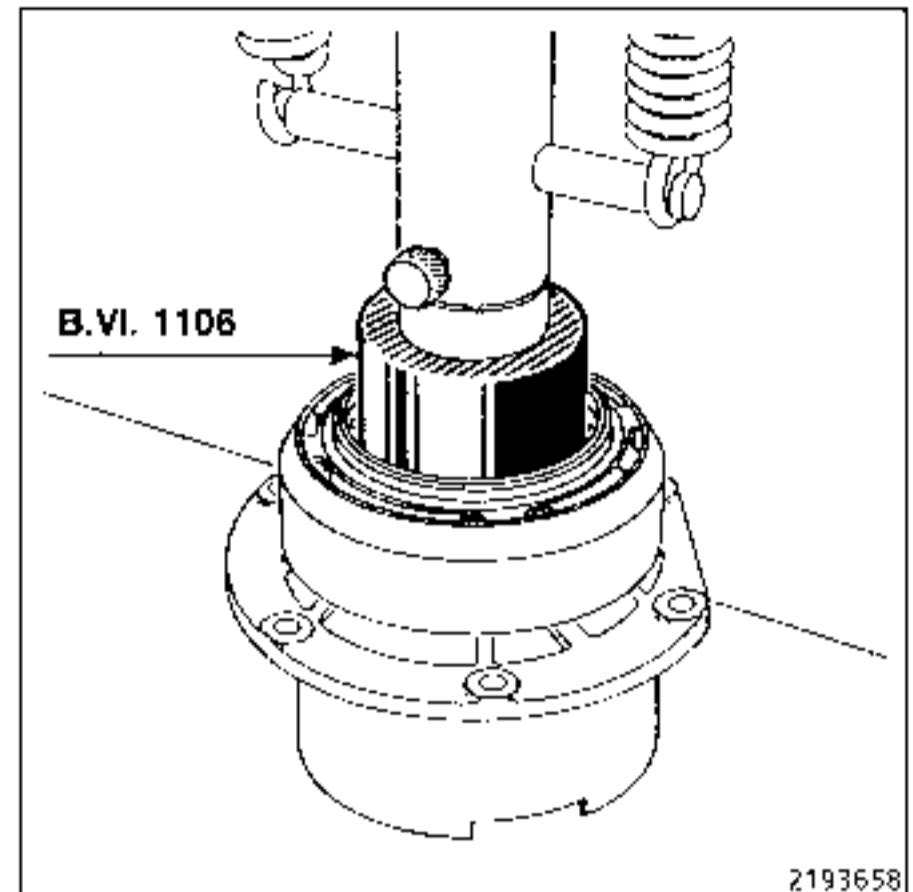
**REPLACEMENT**

Refit:

- the thrust washer,
- the mounting bolt (new, lubricated) and tighten to a torque of 7 to 8 daN.m.

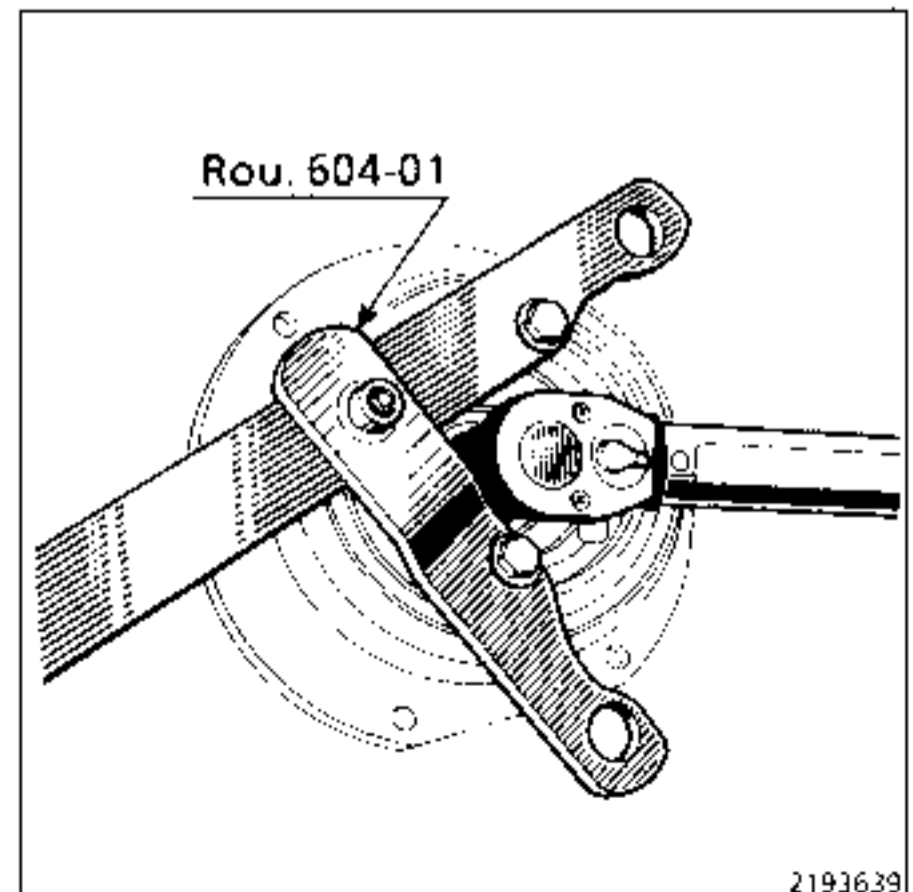

Refit the plastic blanking plug.

MJ3

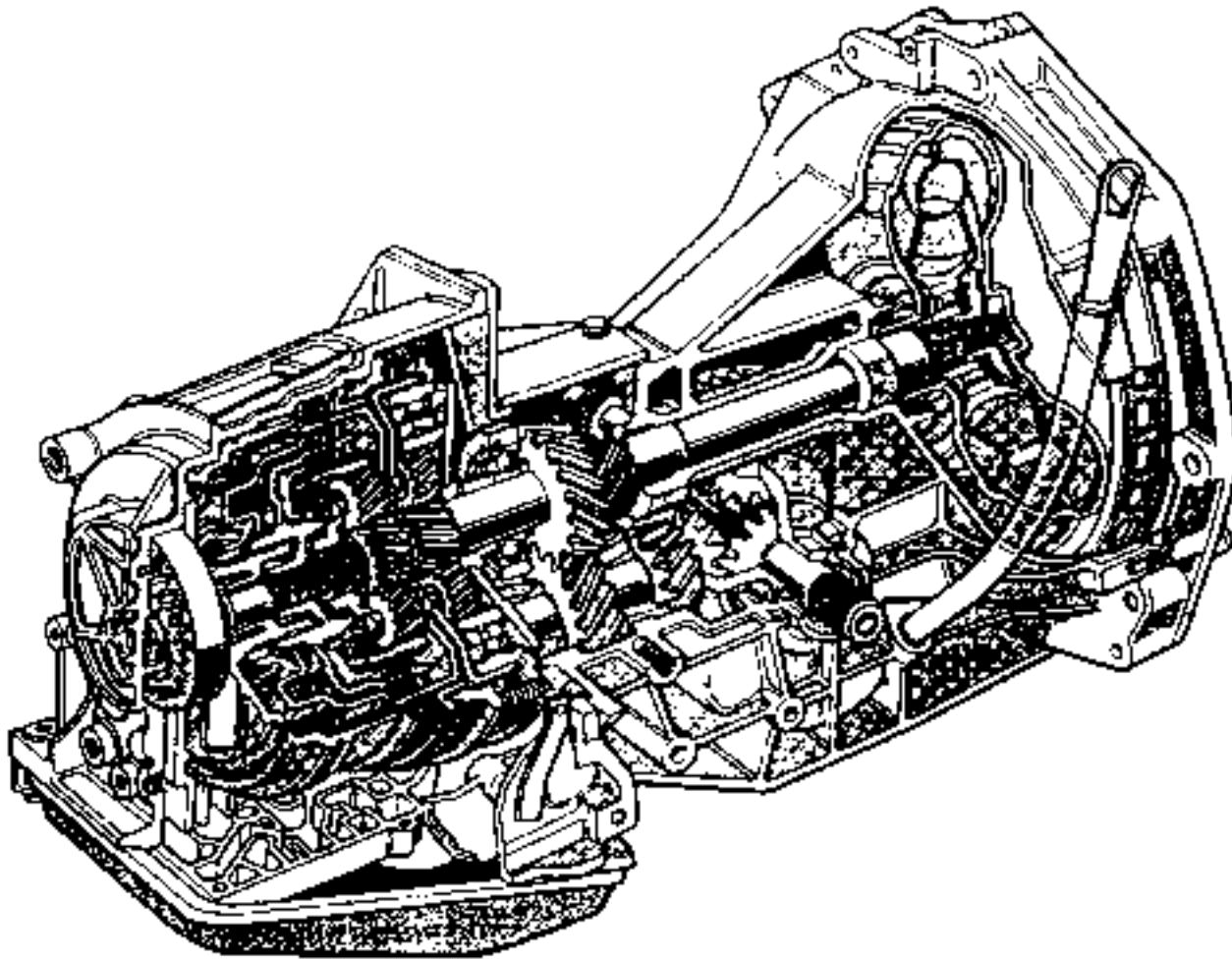

21231 1

AR4

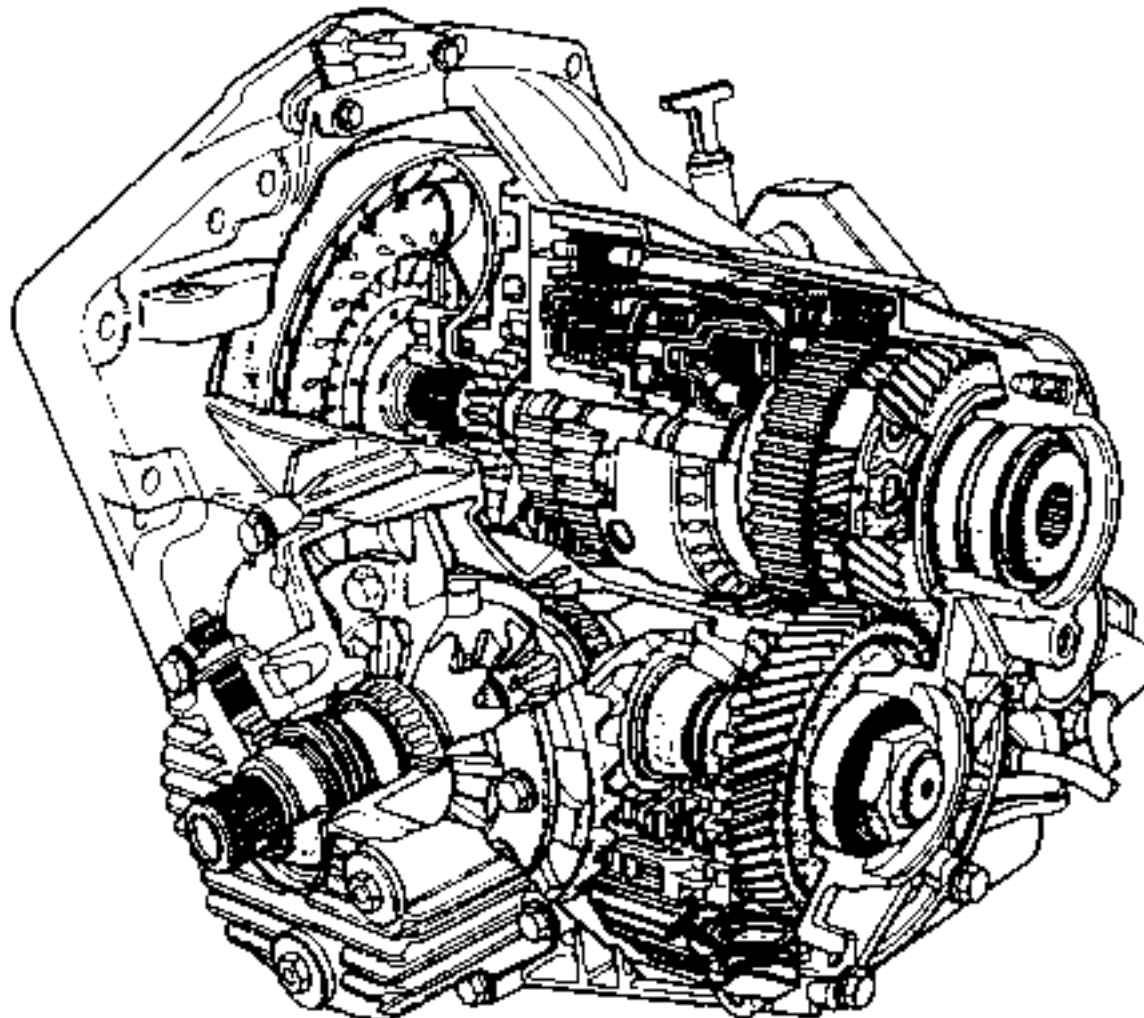

21231 2

AUTOMATIC TRANSMISSION TYPE AD4

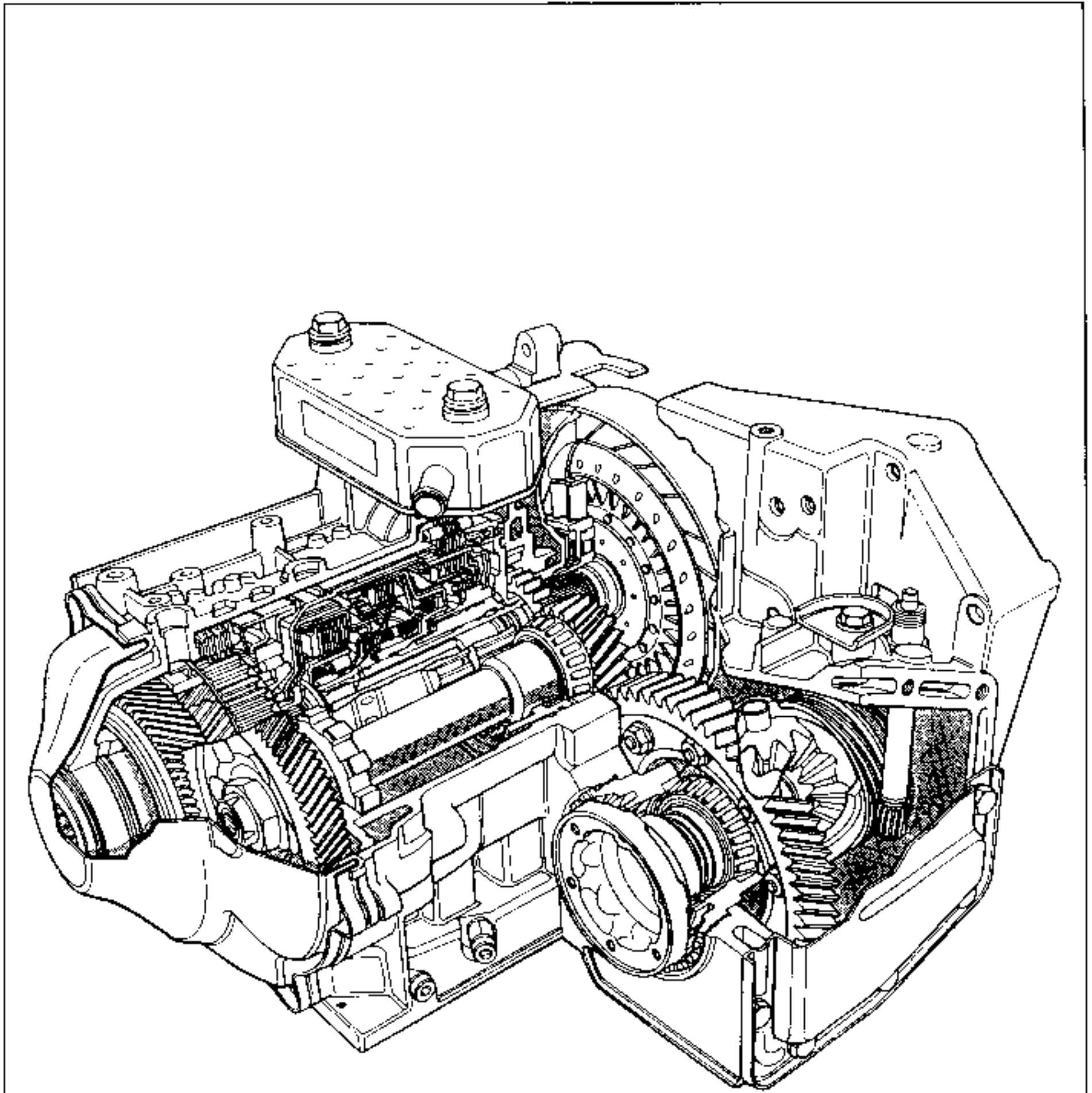

DRIVING

The automatic transmission is lubricated under pressure, which only happens if the engine is running.

Consequently, at the risk of causing serious damage, the following recommendations should be observed

- never drive with the ignition off (down a hill for example), this practice is extremely dangerous,
- never push the vehicle (example to reach a petrol station, unless the precautions specified in the "Towing" section are observed).

The vehicle is also only driven if the engine is running. The engine on a vehicle with automatic transmission cannot be started by pushing the vehicle.

TOWING

In all cases it is preferable to tow the vehicle on a flat bed trailer or with the front wheels lifted. If this is impossible, the vehicle may be towed in exceptional circumstances, under the following conditions:

- 1 - Rear wheels **15 cm** off the ground or all four wheels on the ground (with no oil added to the mechanism).
- 2 - Only tow the vehicle at a speed less than **25 mph** (40 km/h) and for a maximum distance of **15 miles** (25 km) maximum (lever in N).

AUTOMATIC TRANSMISSIONS MJ3 AND AR4

Vehicle	AT type	Suffix	Final drive	Step down	Speedo drive	Oil pressure	Computer number
L 485 B-L-K 489 L-K 483 L-K 48K	MJ3	800 (1) 801 (2)	9/37	26/20	7/19	4.7*	130 126
L-K 483	MJ3	860	9/37	6/19	26/25	4.7	
L-K-B 483	AR4	000 020	9/34	76/85	15/13	Non adjustable	009 014
B-L-K 48C B-L-K 482 B-L-K 48K	AR4	018 025	9/34	76/85	15/13	Non-adjustable	015 029
B-L-K 483 B-L-K 48C B-L-K 48K	AR4	021	9/37	76/85	15/13	Non-adjustable	018
L 48Q	AR4	024	9/34	76/85	15/13	Non-adjustable	019

AUTOMATIC TRANSMISSION AD4

Vehicle	AT type	Converter	Final drive	Step down	Speedo drive	Computer number
X482	AD4000	227 DAA	17/64 or 49/50	18/16	17/64 or 17/70	100
X48E	AD4003	227 DAA	17/64 or 17/70	18/16	17/64 or 17/70	101

- (1) Sump **6 mm** deeper, felt strainer with increased surface, sealed dipstick with reduced level.
- (2) Sump **6 mm** deeper, felt strainer with increased surface, sealed dipstick with reduced level, unidirectional differential output seals (specific to left / right hand sides).
- (*) On the road, lever in 2nd gear hold, accelerate fully (PF - **full load**) and brake at the same time to stabilise the speed at **50 mph** (80 km/h).

CONVERTER DRIVE PLATE

Maximum permitted run-out: **0.3 mm**.

Tightening torque for automatic transmission **MJ3** :

- mounting bolts on crankshaft **7 daN.m**,
- mounting bolts on converter **3 daN.m**.

Tightening torque for automatic transmission **AR4** :

- mounting bolts on crankshaft **6 daN.m**,
- mounting bolts on converter **3.5 daN.m**.

GEAR RATIOS	1st	2nd	3rd	4th	Reverse
Gear reduction - all types	2.71	1.55	1	0.68	2.11

TRANSMISSION AR4

X483 X48K X48C	Overall reduction	11.46	6.55	4.22	2.86	8.91
	Speed in km/h at 1000 rpm with 1.815 m tyres	9.43	16.61	25.77	37.98	12.20
X48Y	Overall reduction	11.45	6.59	4.22	2.86	8.9
	Speed in km/h at 1000 rpm with 1.790 m tyres	9.38	16.4	25.42	37.5	12.58

TRANSMISSION AD4

X482 X48E	Overall reduction	11.40	6.51	4.20	2.85	8.86
	Speed in km/h at 1000 rpm with 1.760 m tyres	9.26	16.20	25.13	37.04	11.90

AUTOMATIC TRANSMISSION MJ3

	1 ↔ 2		2 ↔ 3	
Position of foot	↗	↘	↗	↘
No load in km/h	26*	17	43*	30
Full load in km/h	75	66	122	107

(*) These values are given for information only.

PL : no load - accelerator pedal not depressed.

PF : full load - accelerator pedal fully depressed.

NOTE : the kickdown switch is integral in the computer via the load potentiometer.

IF THERE IS A FAULT, CHECK AND ADJUST THE LOAD POTENTIOMETER (see A.T.M.)

AUTOMATIC TRANSMISSION AR4

A.T. type	Accelerator position	1 → 2		2 → 3		3 → 4		4 → 3		3 → 2		2 → 1	
		A	B	A	B	A	B	A	B	A	B	A	B
AR4 000 020 021	PL in km/h	14		30	35	60	65	50	55	27	30	10	
	PF in km/h	50		87		140		97	120	50	55	30	
AR4 024	PL in km/h	15		40		60	65	52		32		9	
	PF in km/h	41	51	75	93	124	150	102	130	60	80	32	
AR4 018 025	PL in km/h	14		30	34	60	66	50	53	27	30	10	
	PF in km/h	45	52	82		130		125		47	75	33	50

Tolerances ± 10 %.

PL : no load - accelerator pedal not depressed.

PF : full load - accelerator pedal fully depressed.

A : gear change thresholds offset in upward direction*.

B : gear change thresholds offset in downward direction*.

(*) See note on following page.

AUTOMATIC TRANSMISSION AD4

Vehicles	AT type	Accelerator position	1 → 2		2 → 3		3 → 4		4 → 3		3 → 2		2 → 1	
			A	B	A	B	A	B	A	B	A	B	A	B
X 487	AD4 000	PL	17	20	35	40	60	70	46	51	31		10	
		PF	41	46	76	83	120	130	103	112	46	68	26	30
		RC	48		88		136		130	133	85		41	45
X 48E	AD4 003	PL	17	20	35	40	60	70	47	50	30		10	
		PF	36	42	70	80	117	128	103	112	52	68	26	30
		RC	42	44	80		131		130		78	81	40	

The values given in the table are theoretical average gear change threshold values in km/h, tolerance $\pm 10\%$.

- PL** : no load - accelerator pedal not depressed.
- PF** : full load - accelerator pedal fully depressed.
- RC** : kickdown (change down to a lower gear).

- A** : gear change thresholds offset in downward direction. Gears change at lower engine speeds. Switch (1) is depressed and warning light E on the instrument panel is illuminated.
- B** : gear change thresholds offset in upward direction. Gears change at higher engine speeds. Switch (1) is not depressed and warning light E is extinguished.

NOTE :

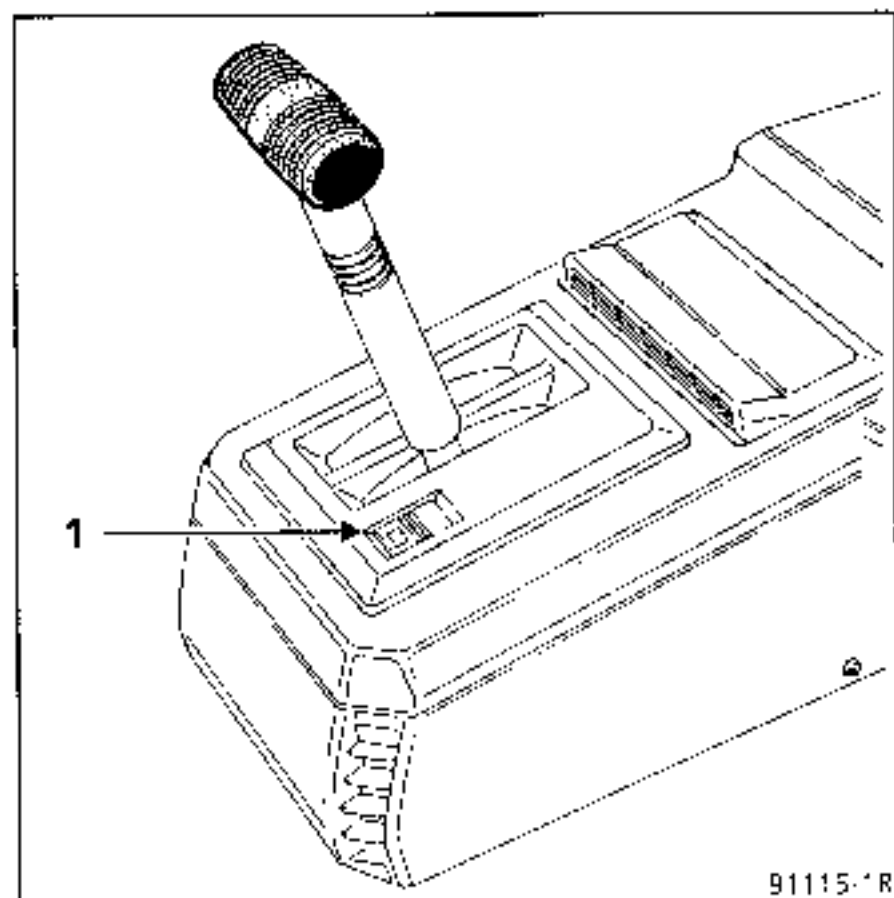

SPECIAL NOTES FOR AUTOMATIC TRANSMISSION AR4

Up to model year 1989

Press switch 1, warning light **PERF** illuminates, the gears change at higher engine speeds.

From model year 1990

Press switch 1, warning light **E** illuminates, the gears change at lower engine speeds.

GRADE

AUTOMATIC TRANSMISSION MJ3

Then same oil is used for the converter, the final drive and the mechanism.

Grade : **ELF RENAULTMATIC D2.**

AUTOMATIC TRANSMISSION AR4

Mechanism : **ELF RENAULTMATIC D2.**

Final drive : **80W-B.**

AUTOMATIC TRANSMISSION AD4

Mechanism : **ELF RENAULTMATIC D2.**

Final drive : **TRANSELF TRX 76W 80W.**

AUTOMATIC TRANSMISSION MJ

OIL CAPACITY

	Total volume	Volume after draining
Mechanism	6 litres	2.5 litres

AUTOMATIC TRANSMISSION AR4

OIL CAPACITY

	Total volume	Volume after draining
Mechanism	5.7 litres	4 litres
Final drive	0.85 litres	0.8 litres

AUTOMATIC TRANSMISSION AD4

OIL CAPACITY

	Total volume	Volume after draining
Mechanism	5.7 litres	3.5 litres
Final drive	1 litre	-

NOTE : if the automatic transmission is to be replaced, only the level needs to be checked as the component is supplied ready filled from the Parts Department.

Materials

DESCRIPTION	COMPONENT CONCERNED
RHODORSEAL 5661	Sealing driveshaft roll pins
MOLYKOTE BR2 grease	- Sunwheel splines - Converter centring device
LOCTITE FRENBLÖC	Brake caliper mounting bolts

Parts to be replaced systematically

Parts to be renewed when they are removed:

- roll pins,
- self locking nuts,
- copper seals.

The oil must be changed when cold, with the dipstick and plug (A) removed.

Renew the strainer.

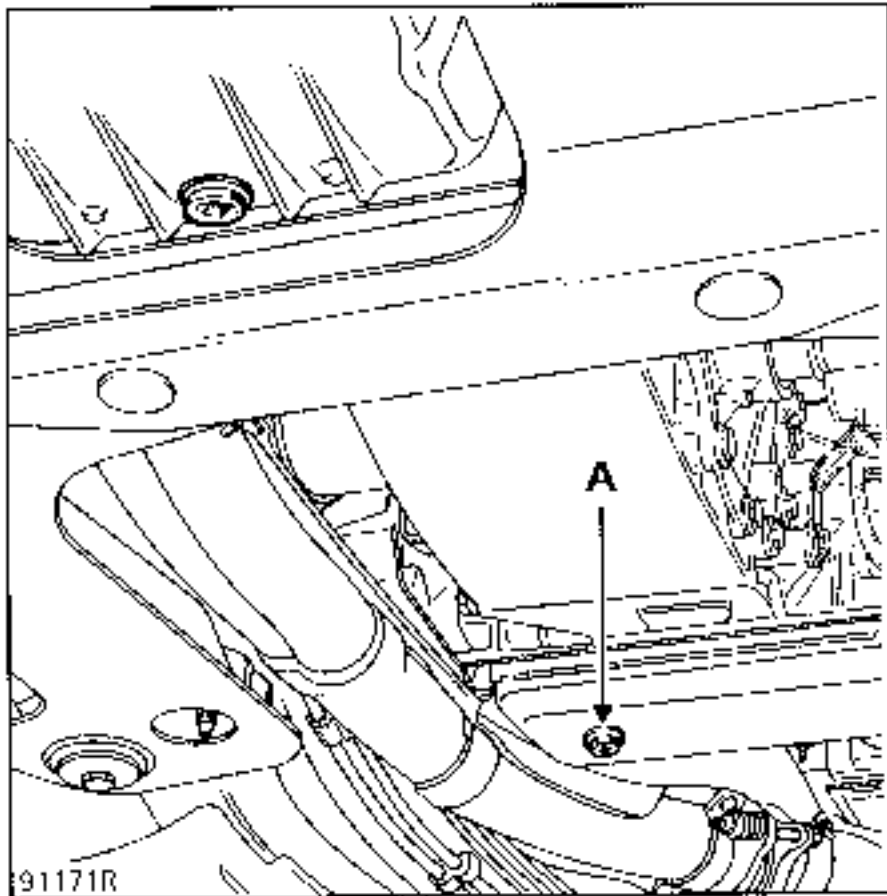

Refit the plug, with a new seal.

The transmission is filled via the dipstick tube.

Use a funnel fitted with a **15/100** filter, to prevent foreign bodies from entering the transmission.

Use the recommended oil.

Run the engine at idle speed, check the level and top up if necessary.

CHECKING THE OIL LEVEL WHEN COLD

IMPORTANT: in order to ensure that the level is correct, ensure the dipstick is to specification.

MJ800 and **MJ801**, blue in colour.
L = **247 mm**.

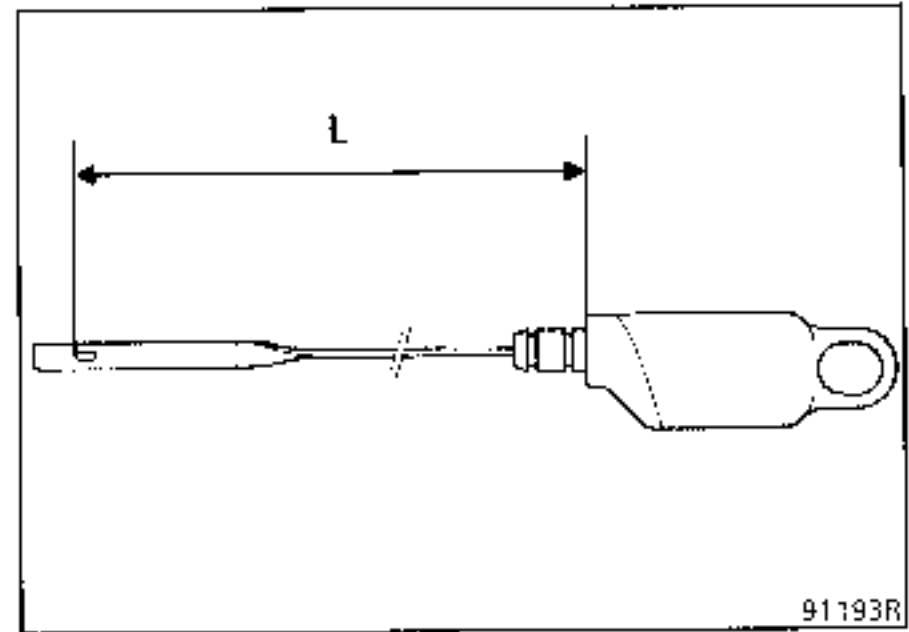

Vehicle unladen.

Put the vehicle on a flat, horizontal surface.

Position the selector lever in "**PARK**" (P).

Start the engine and wait for **1 to 2 minutes** to allow the converter and cooler to fill with oil.

The oil is at ambient temperature (**20 °C**).

Remove the dipstick with the engine running.

The level should not be below mark (1) "MINIMUM COLD" (risk of damage) and should not exceed mark (2) "MAXIMUM COLD" (risk of damage).

Never fill beyond the mark "MAXIMUM COLD".

IMPORTANT:

If there is too much oil, this will cause:

- abnormal overheating of the oil, leaks.

Too little oil will cause the mechanism to be damaged.

AUTOMATIC TRANSMISSION AR4

FINAL DRIVE

The final drive is drained via plug (A). It is filled and the level checked via plug (B) by overflow after injection 0.80 litres of oil (see previous page).

MECHANISM

There is no drain plug for the mechanism housing.

The oil is drained by removing the level checking plug (C) (some oil will run out) and removing the sump.

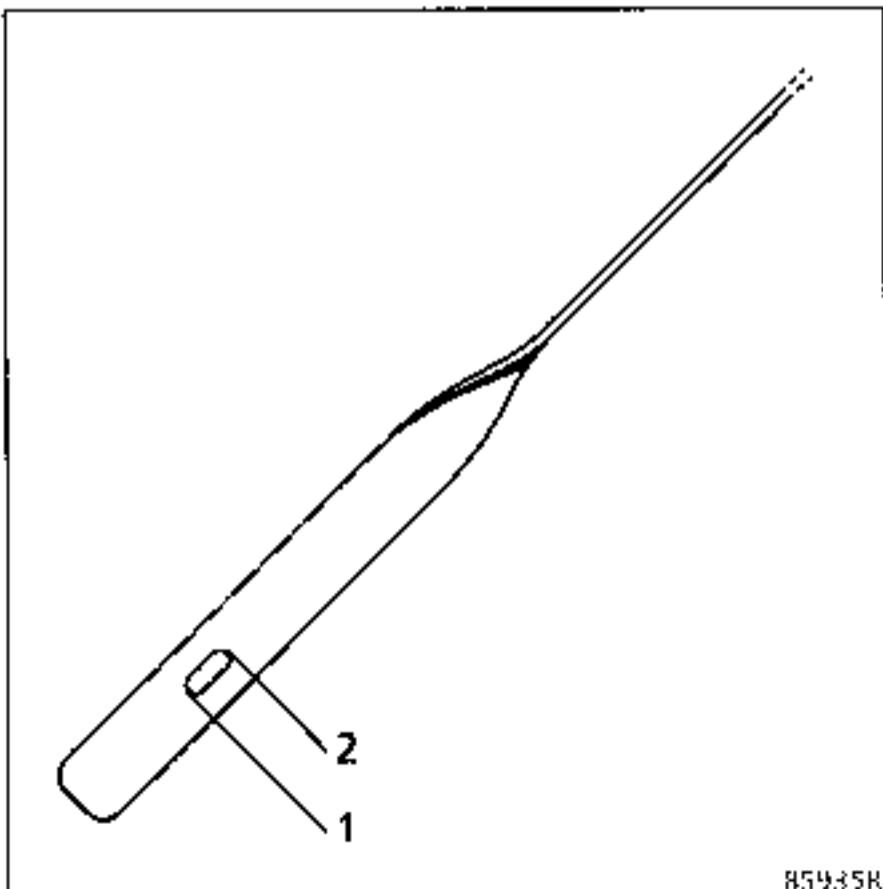
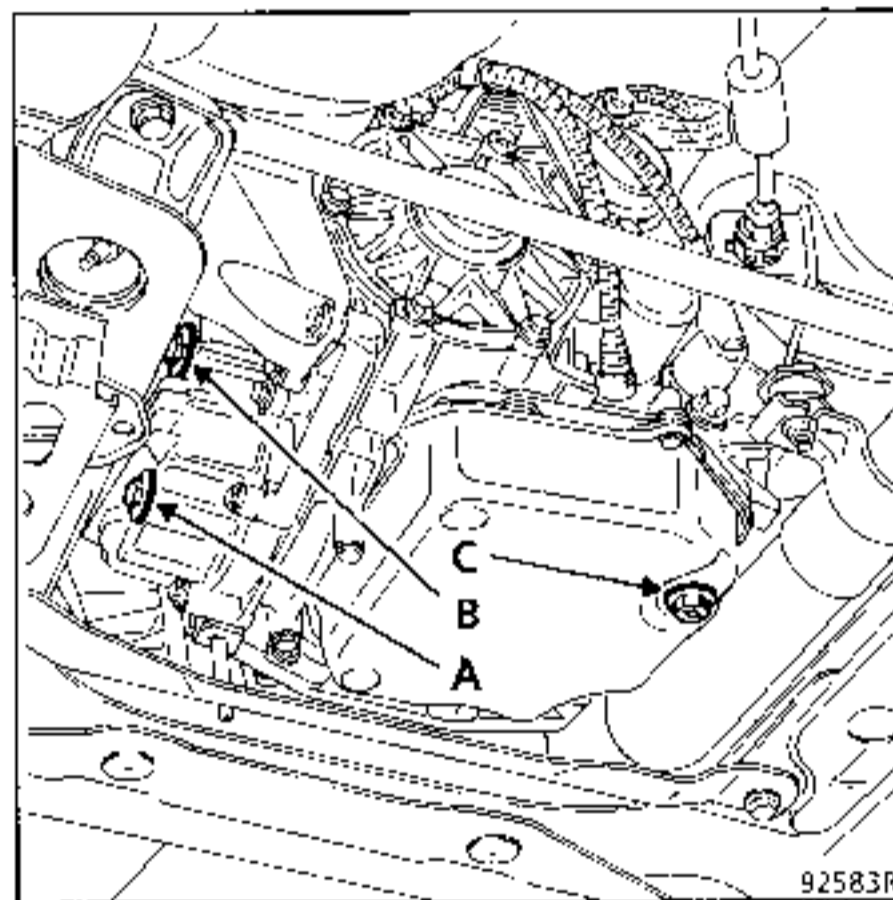
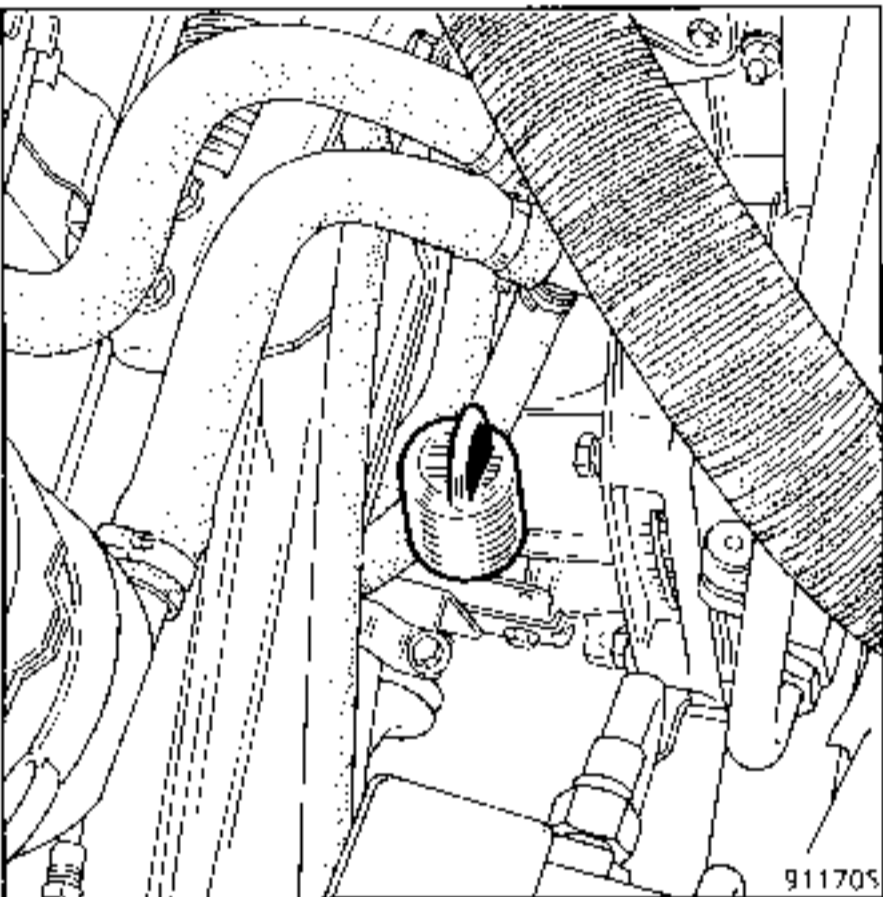

It is filled via tube (D).

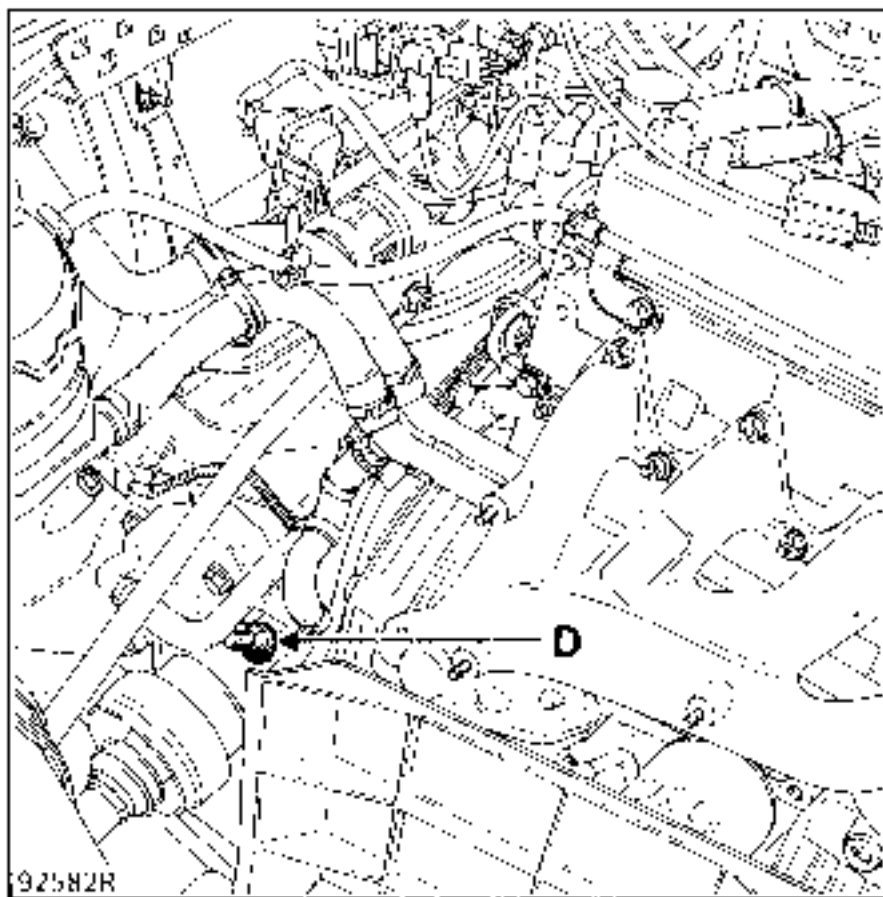

Use a funnel fitted with a 15/100 filter, to prevent foreign bodies from entering the transmission.

Use the recommended oil.

If the transmission has been drained, add 4 litres of oil.

If only the level is being checked or the transmission is new, add 0.5 litres of recommended oil.

The level **MUST** be checked by following the method below:

1. Vehicle on a **four post lift**, transmission at ambient temperature.
2. Start the engine, selector lever in Park.
3. Connect the **XR25**, then enter:

D	0	4	then	#	0	4
---	---	---	------	---	---	---
4. Lift the vehicle.
5. Let the engine run until it reaches a temperature of **60 °C**.

When the required temperature has been reached, with the engine running, open the level checking plug, allow the excess oil to run out (which must be greater than **0.1 litres**) for approximately **20 seconds**. A thin stream of oil should continue to run out.

Refit the plug.

If the volume of oil collected is less than **0.1 litres**, the level is incorrect and the operation must be repeated.

In this case, add another **1 litre** of recommended oil.

Allow the transmission to cool and then repeat the operations in sequence.

SPECIAL TOOLING REQUIRED

B.Vi.	1213	Transmission drain spanner
M.S.	1019-10	XR25 test kit

DRAINING

● Mechanism:

The mechanism housing has two plugs:

- A : level checking plug,
- B : drain plug (triangular mark).

The mechanism is drained by removing plug (B).

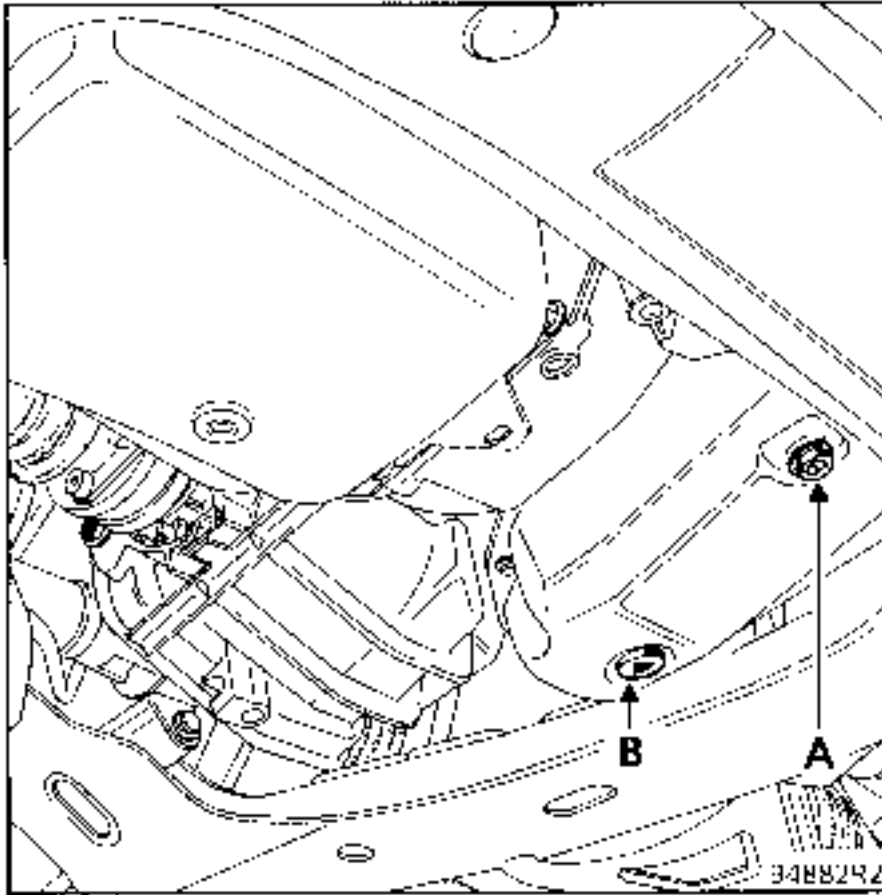

● Final drive:

The final drive is filled and the level checked via plug (C) by overflow, after injecting oil.

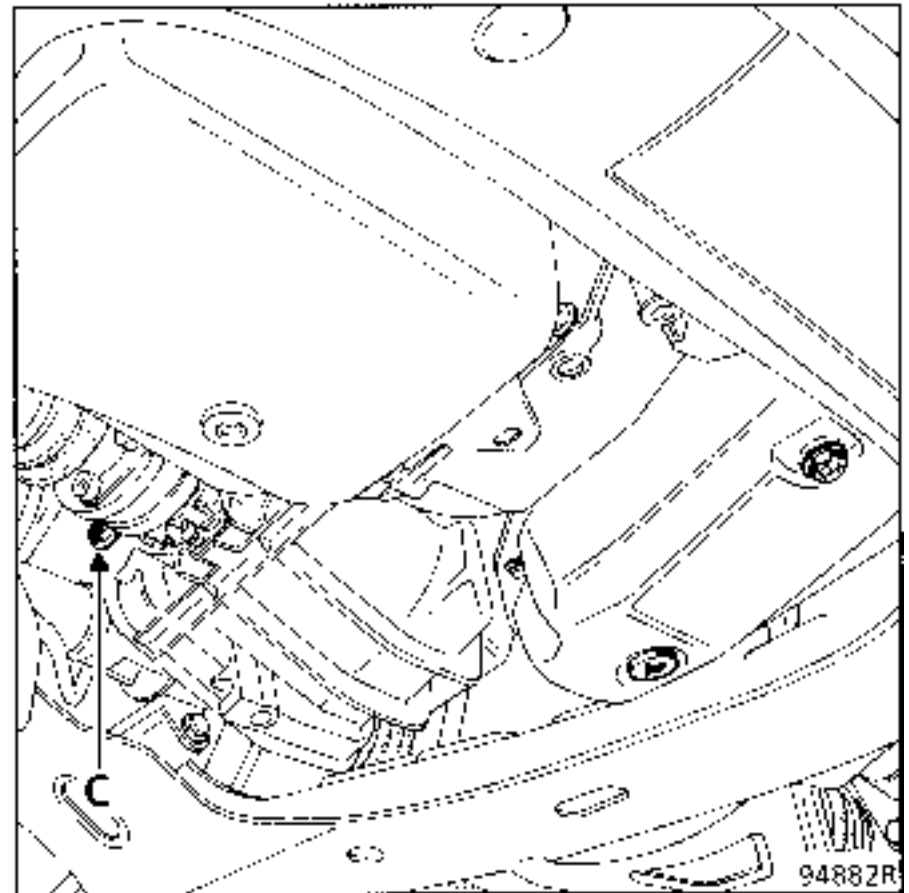

REMINDER: The final drive is not drained it is filled for life.

FILLING - LEVELS

The transmission is filled via tube (D).

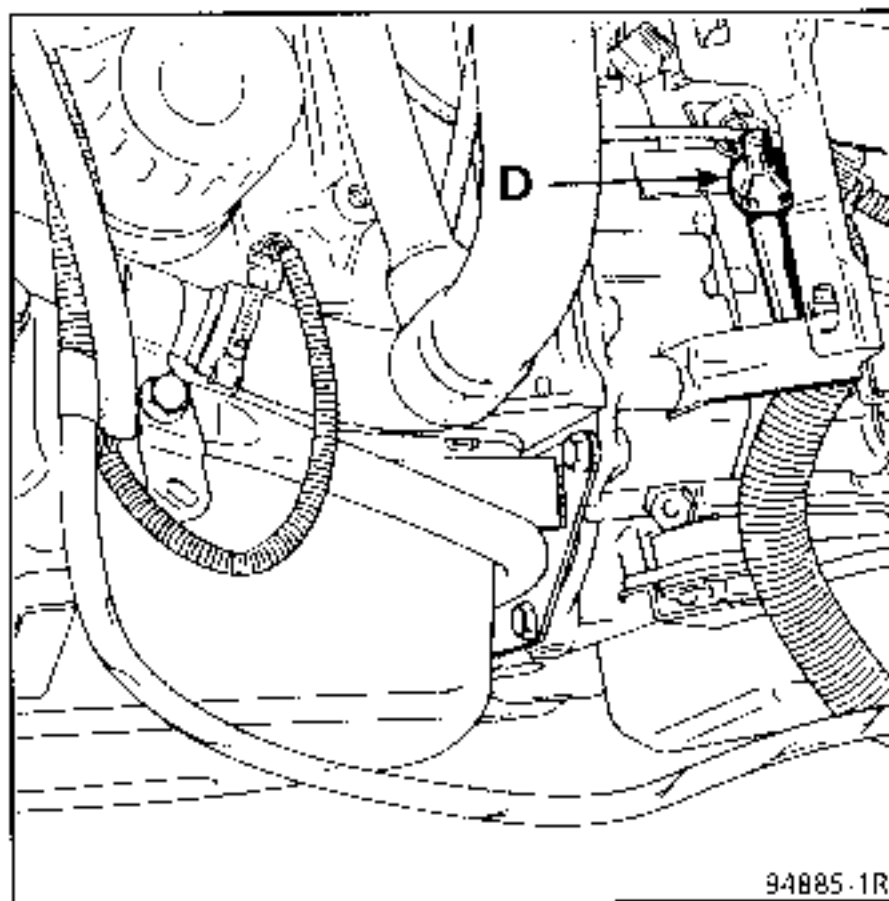

Use a funnel fitted with a 15/100 filter, to prevent foreign bodies from entering the transmission.

The level **MUST** be checked by following the method below:

Before this:

- if the transmission has been drained, add 3.5 litres of oil,
- if the level is just being checked, add 0.5 litres of recommended oil.

1. Vehicle on a **four post lift**, transmission at ambient temperature.
2. Start the engine, selector lever in Park.
3. Connect the XR25, then enter:

D	0	4	then	#	0	4
---	---	---	------	---	---	---
4. Lift the vehicle and let the engine run until it reaches a temperature of **60 °C**.
5. When the required temperature has been reached, with the engine running, open the level checking plug, allow the excess oil to run out (which must be greater than **0.1 litres**) for approximately **20 seconds**. Refit the plug.
6. If the volume of oil collected is less than **0.1 litres**, the level is incorrect and the operation must be repeated.

In this case, add another **1 litre** of recommended oil. Allow the transmission to cool and then repeat the operations in sequence.

MESSAGE FROM ELECTRONIC FAULT WARNING LIGHT

Operation with no fault present

- When the ignition is turned on, vehicle stationary and engine not running, lever in **P** or **N**, warning light illuminates.
- When the starter is activated, warning light remains illuminated.
- When the key is released, ignition on, engine running, it extinguishes approximately **3 seconds** after the engine starts.

Fault present

- Vehicle stationary, engine running or when driving, warning light illuminated permanently.
- Vehicle moving, warning light illuminates and extinguishes with no action at the ignition key.
- Vehicle moving, warning light illuminates briefly.

Oil temperature $< -20\text{ }^{\circ}\text{C}$ or $> +140\text{ }^{\circ}\text{C}$

- Vehicle moving or stationary, warning light flashes **approximately once a second**. In this case, reduce the requirement for performance by moderating acceleration.

Oil pressure (1)

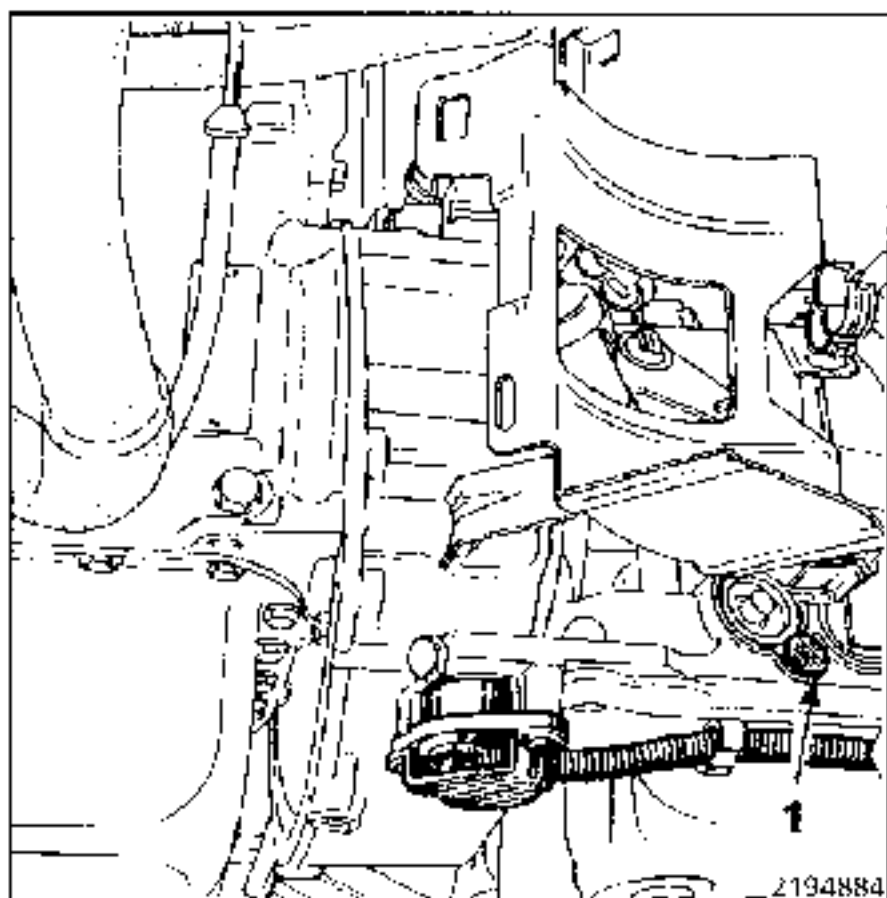

The transmission has an oil pressure socket. Connect tool **B.Vi. 1215** to check the automatic transmission pressure sensor only.

The oil pressure cannot be adjusted.

Its value is determined by the computer.

The strainer is used to filter the oil and guarantee that the automatic transmission operates correctly.

AUTOMATIC TRANSMISSION M1

TIGHTENING TORQUES (in daN.m) 	
Distributor mounting bolt (strainer mounting bolt)	0.9
Sump mounting bolt	0.6

REMOVAL

Drain and remove:

- the sump,
- the strainer and its seal.

Before refitting, clean the sump and the magnets.

REFITTING

Refit:

- the new strainer fitted with its seal and torque tighten to **0.9 daN.m**, the sump, and top up the oil.

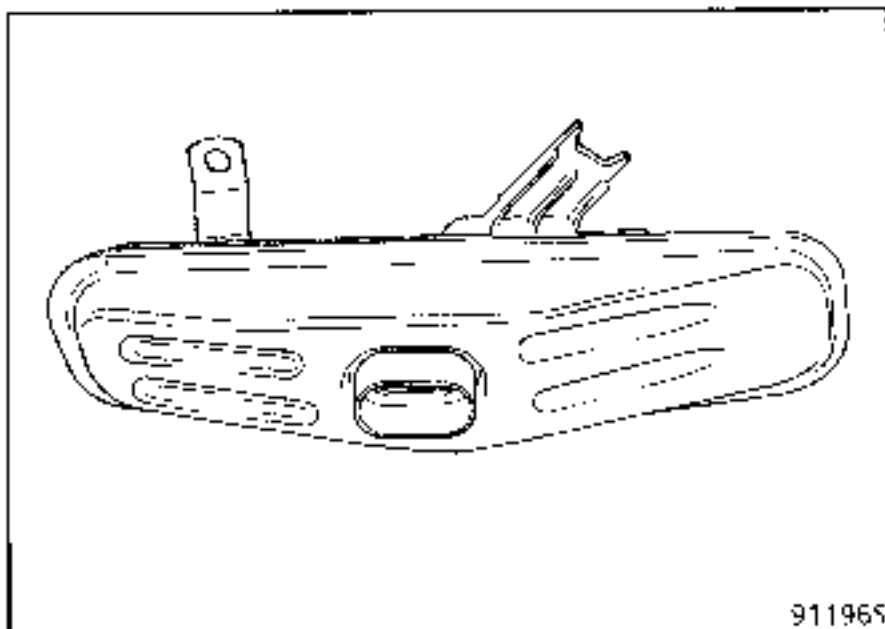

AUTOMATIC TRANSMISSION AR4

TIGHTENING TORQUES (in daN.m) 	
Strainer mounting bolt	0.5
Sump mounting bolt	1 ± 0.1

IMPORTANT: the strainer is no longer replaced during servicing on this type of transmission.

REMOVAL

Drain the transmission (mechanism section).

Remove:

- the sump,
- the strainer and its seal (bolts 1).

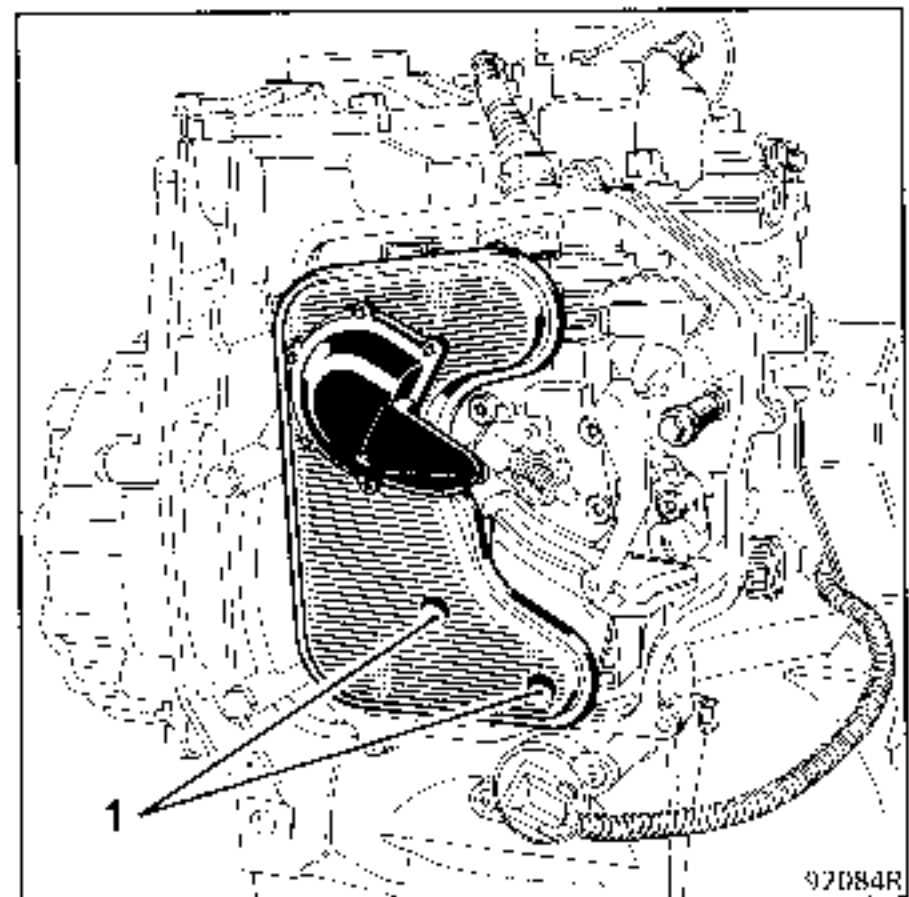

Before refitting, clean the sump and the magnet.

Check the condition of the sump seal and the top-ping up plug.

REFITTING

Refit the strainer and the seal.

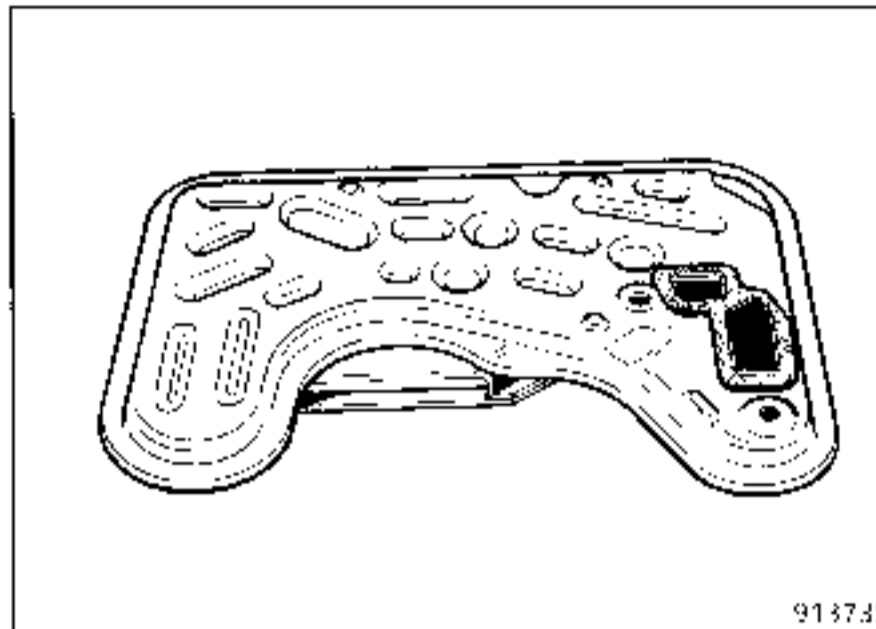

Tighten the bolts to a torque of **0.5 daN.m**.
Fit the sump and tighten the bolts to a torque of **1 ± 0.1 daN.m**.
Fill the transmission with oil.
Check the level (see section "Oil drain - Refilling").

IMPORTANT:

If the following faults:

- delay in engaging forward gears and reverse engages with jerks,
 - slip in 1st gear and reverse,
- appear especially when cold and immediately after servicing the automatic transmission when the strainer was replaced, check:
- the strainer seal is present and is in good condition,
 - the flatness of the seal bearing face on the strainer - check using a straight edge,
 - that the strainer is correctly positioned in the hydraulic distributor aperture.

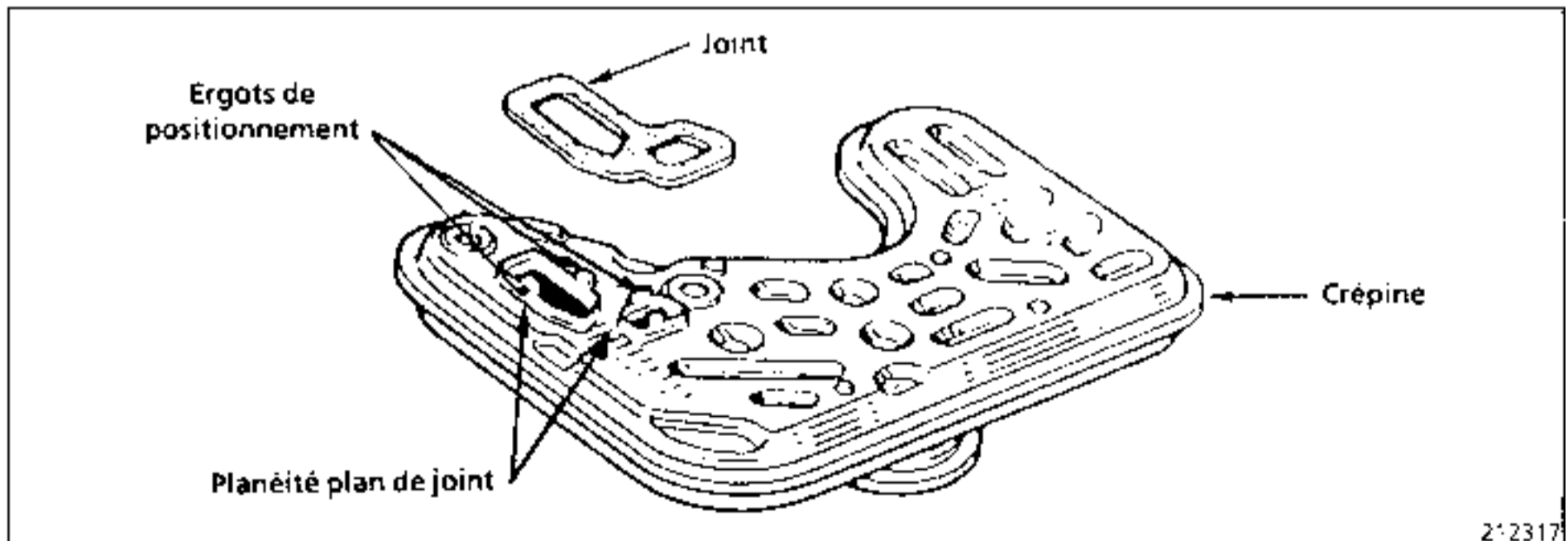

Even when performed by a professional who is used to the operation, replacing the strainer on **AR4** or **AD4** transmissions is still a difficult operation.

Before refitting the strainer it is necessary to check:

- the flatness of the sealing face on the strainer at the intake openings (there should be no deformation),
- that the seal is in good condition and is correctly positioned on the strainer.

Align the strainer under the distributor: the positioning lugs should enter the distributor openings.

Tighten the mounting bolts and then torque tighten them to **0.5 daN.m**.

IMPORTANT: the strainer is no longer replaced during servicing on this type of transmission.

TIGHTENING TORQUES (in daN.m)		
Strainer mounting bolt	0.5	
Sump mounting bolt	1 ± 0.1	
Front mounting pad mounting nut	4	
Bolt for rear mounting	6.5	
Bolt for transmission mounting pad	2	
Wheel bolts	9	

REMOVAL

Put the vehicle on a 2 post lift and fit the anti-tilt clamps to the pads.

Drain the transmission (mechanism section).

Remove:

- the expansion bottle,
- the power assisted steering fluid reservoir.

Remove the mounting bracket for the power assisted steering hoses.

Release the wiring to reach the four mounting bolts for the transmission mounting pad.

Remove the two upper bolts (A) for the mounting pad and slacken the two other bolts (B), without removing them.

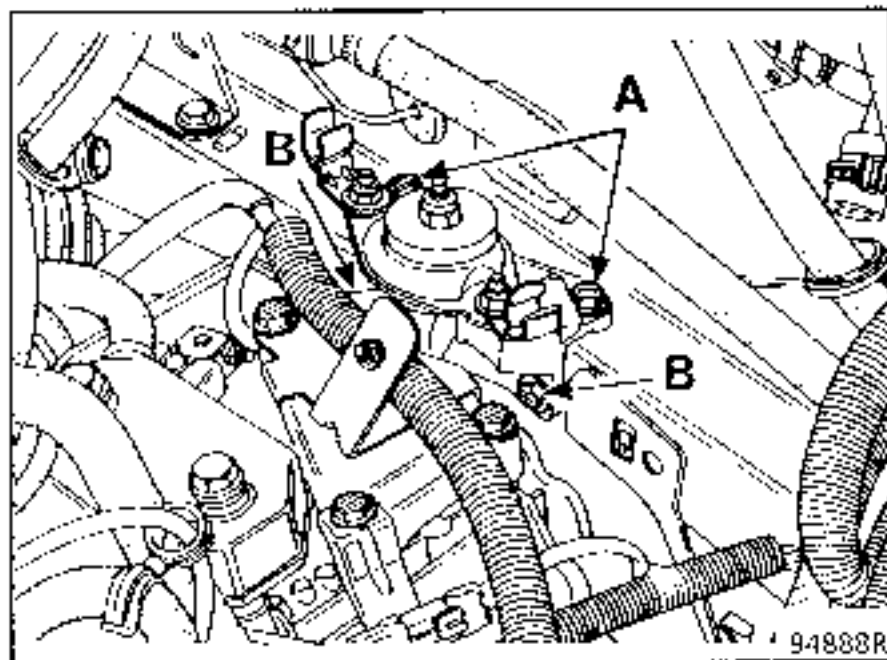

Slacken bolt (1) on the rear centre mounting.

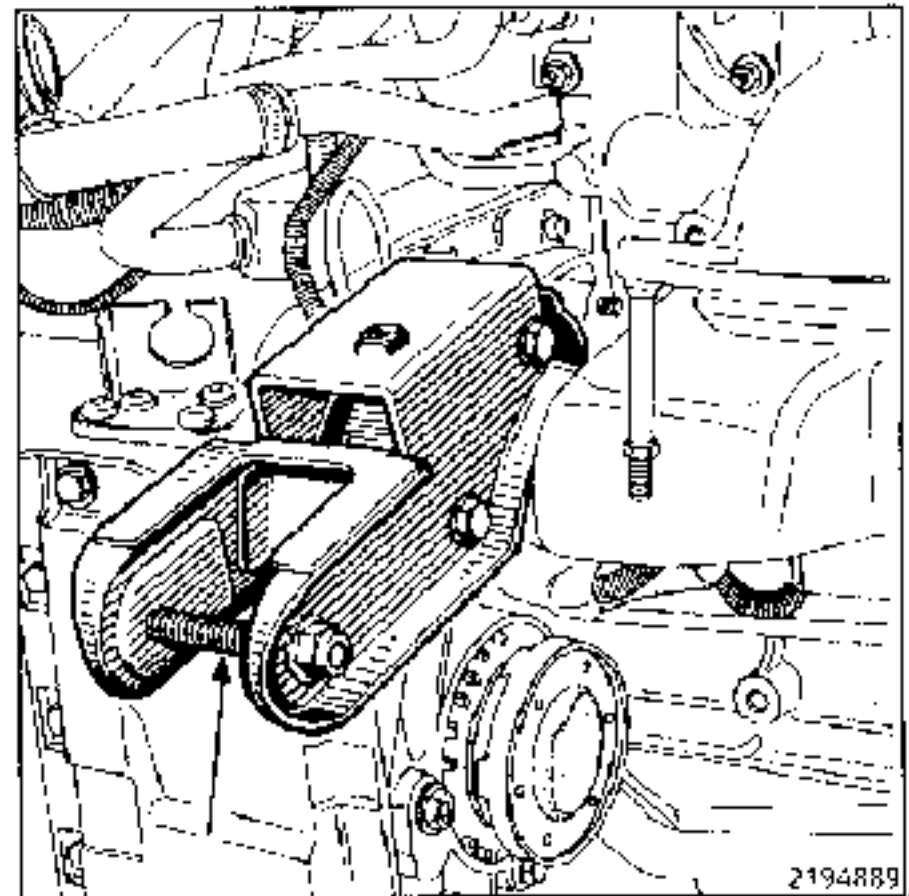

Remove the front left hand wheel.

Remove the side deflector (1 bolt and 3 rivets) and in preparation for later on, remove the mounting bolts for the transmission sump.

Remove the mounting nut for the front mounting.

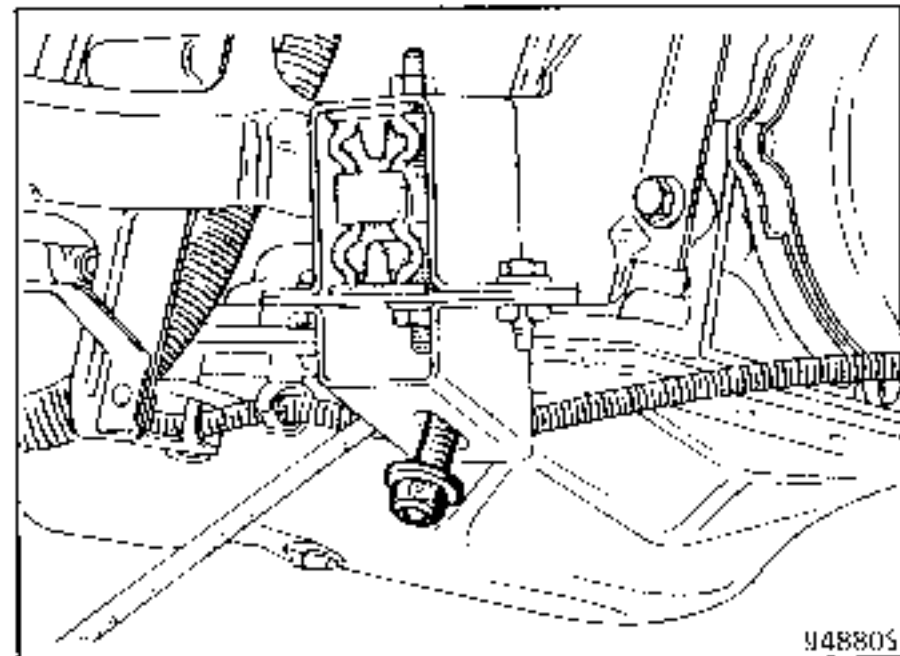

Lift the automatic transmission using a component jack.

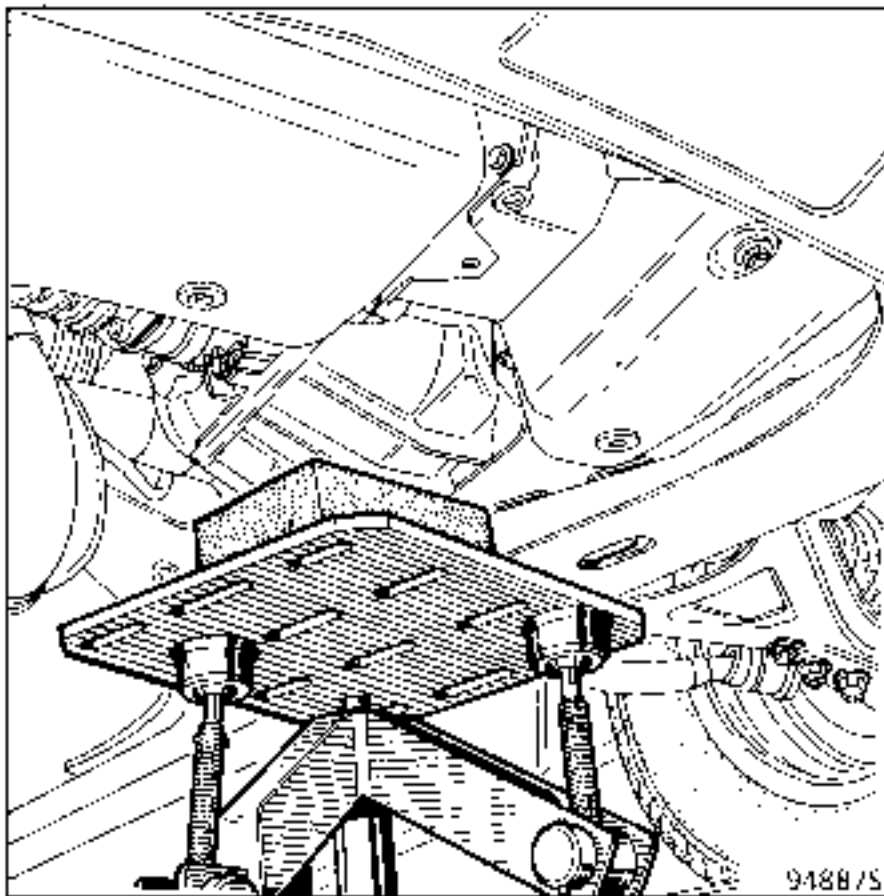

Remove:

- the automatic transmission sump,
- the strainer and its seal (bolts 1).

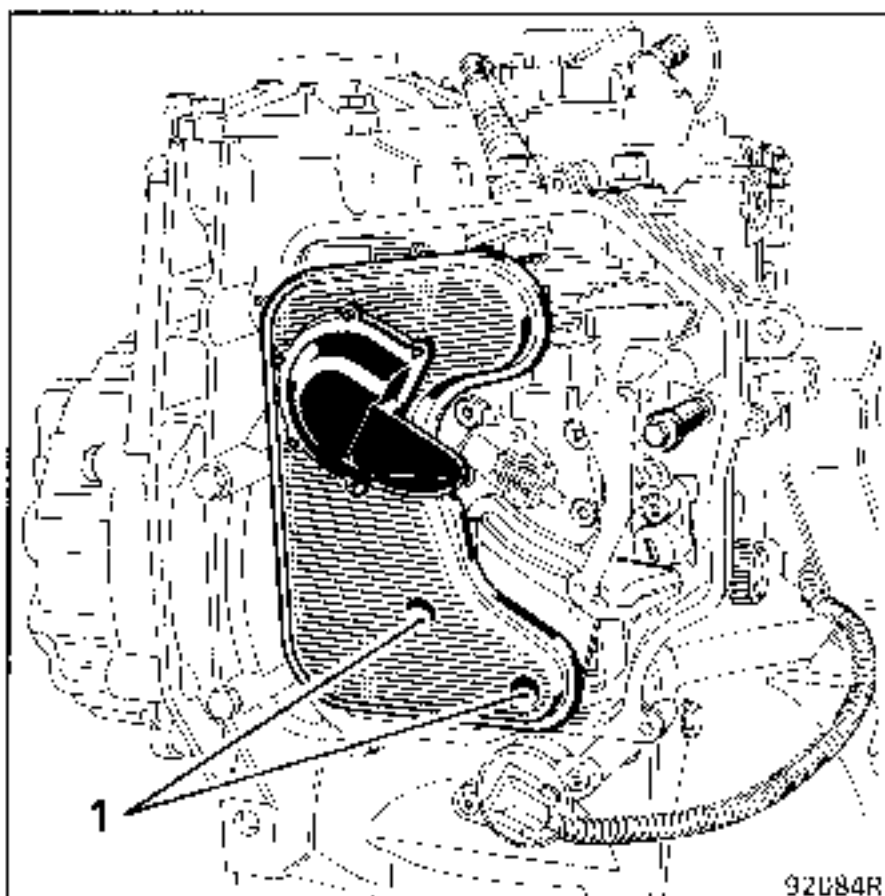

Before refitting, clean the sump and the magnet.

Check the condition of the sump seal and the drain and level checking plugs.

REFITTING

Refit the new strainer and its seal. Tighten the bolts to a torque of **0.5 daN.m**.

Fit the sump and tighten the bolts to a torque of **1 daN.m**.

Refit the transmission mounting pad bolts.

Refit the rear centre mounting pad bolt and tighten it to a torque of **6.5 daN.m**.

Refit the wiring.

Refit the mounting bracket for the power assisted steering hoses.

Refit the power assisted steering reservoir and the expansion bottle.

Tighten the mounting nut for the front mounting to a torque of **4 daN.m**.

Refit the front left hand side deflector and the wheel.

Fill the transmission with oil and check the level.

The hydraulic distributor ensures the supply (and return) of oil to the clutches and brakes, depending on feed to the solenoid valves.

TIGHTENING TORQUES (in daN.m)	
Distributor mounting bolt	0.9
Sump mounting bolt	0.6
Cover plate mounting bolt	1.3

REMOVAL - CHECKING - REFITTING

REMOVAL

Drain and remove :

- the sump,
- the strainer and retain its seal (J),
- all the distributor bolts except bolt (A).

When removing bolt (A), take care to prevent the following components falling out:

- the manual valve (14),
- the plate and the two seals located under the distributor.

Remove pin (E) from the sealed connector and remove the distributor / solenoid valves assembly.

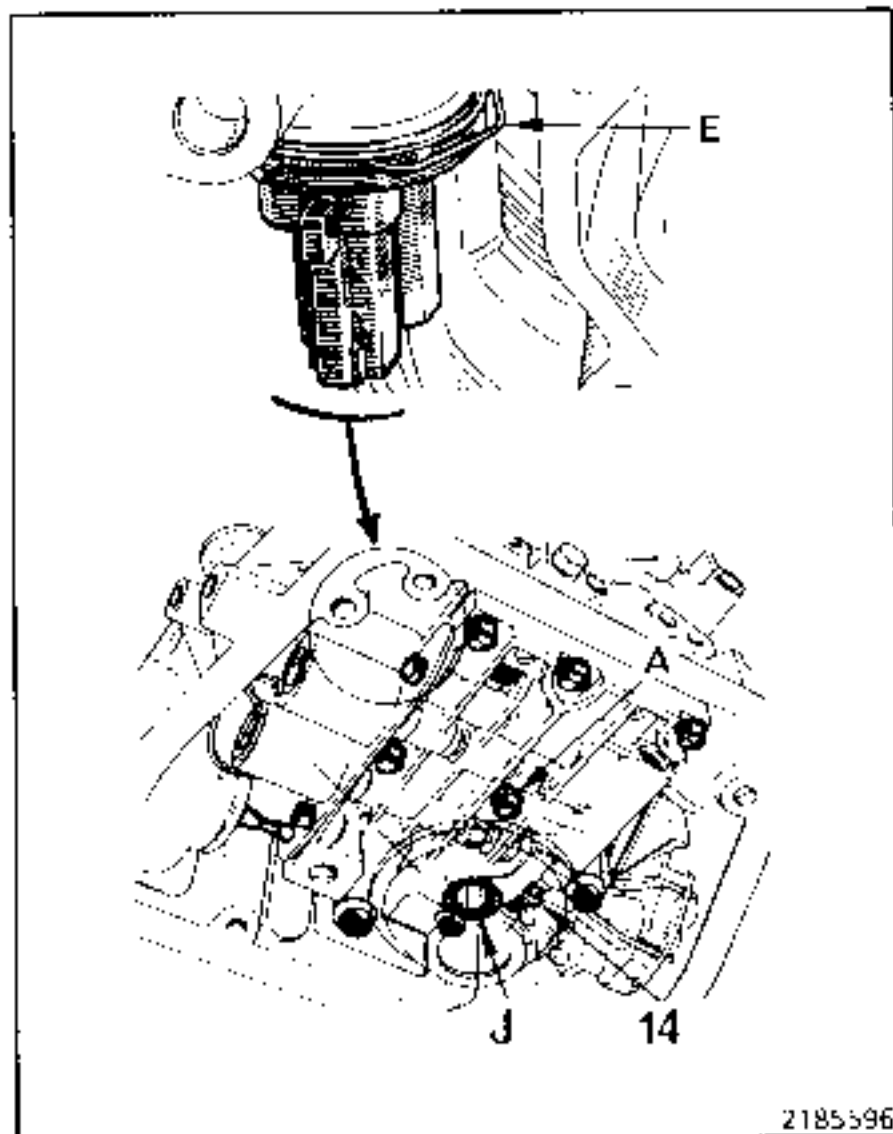

CHECKING

Check that the sequence valves (6) and (7) slide freely at A using a small screwdriver and check the other valves. **TAKE CARE** not to make scratches.

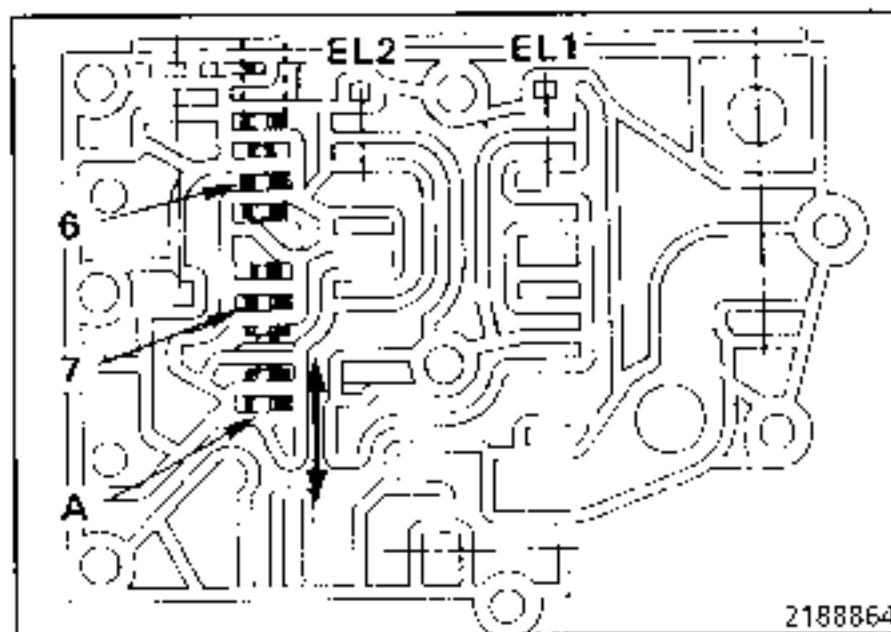

REFITTING

Fit pin (E) to the sealed connector socket and re-connect it.

Position the manual valve (14) in line with the toothed sector.

The vacuum capsule on the pressure regulation valve (11).

Tighten the bolts (2) and (6) on the distributor as far as possible since they determine its position when all the bolts are tightened.

Using a torque wrench (0.3 to 2 daN.m), tighten the hydraulic distributor bolts in the recommended order to a torque of 0.9 daN.m.

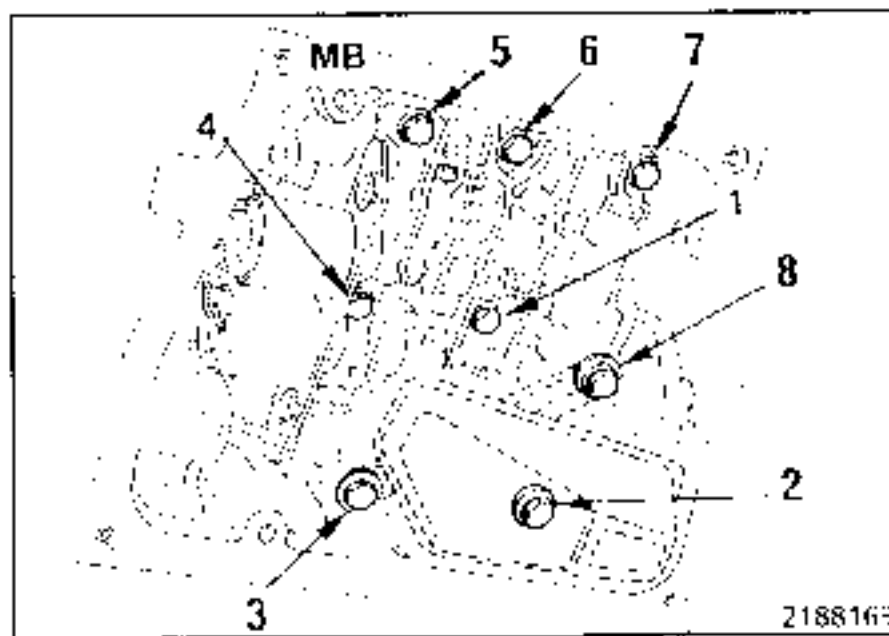

REMOVAL - CHECKING - REFITTING (cont)

MJ

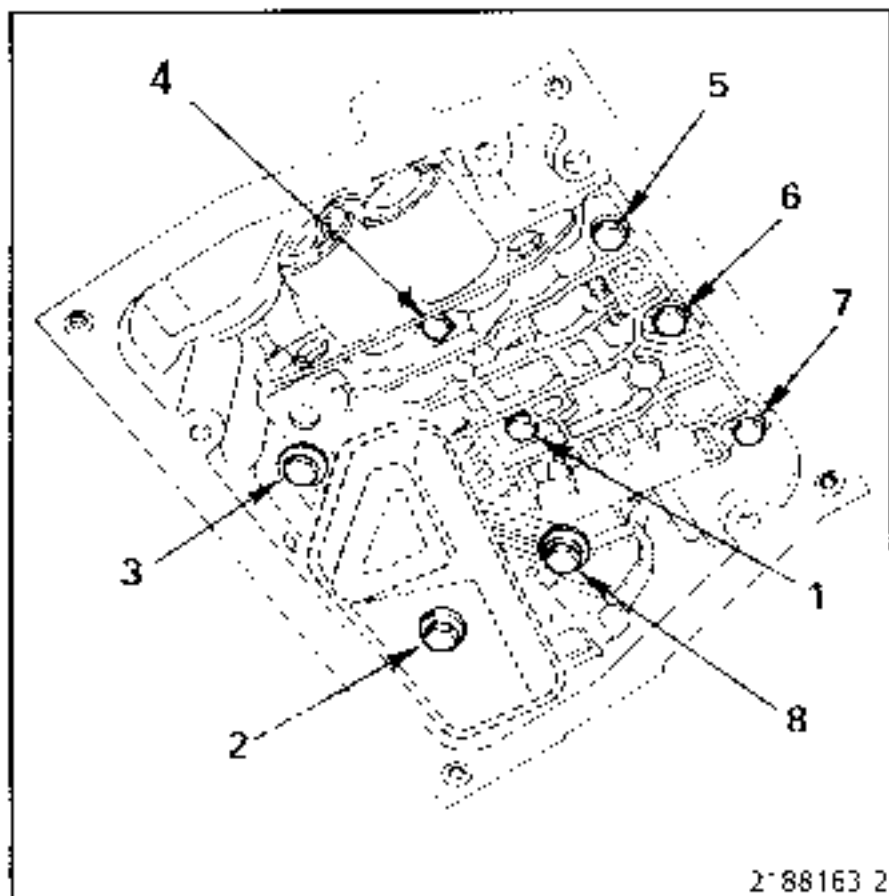

After tightening bolts (1) and (2), fit the new strainer (as shown in the diagram) with its seal.

After fitting, check the manual valve moves correctly.

1st assembly

The stop bolt (B) prevents the manual valve (14) falling out at the end of its travel.

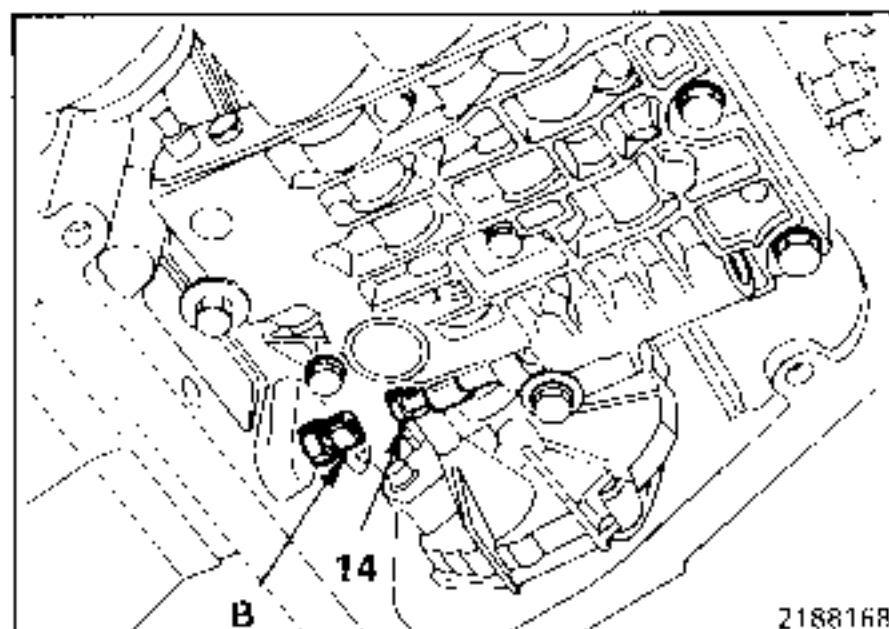
**Adjusting the stop bolt (B) :**

- Place the selector lever in "Park".
- Slacken the lock nut and bring bolt (B) to 1 mm from the manual valve.
- Tighten the lock nut.

2nd assembly

The Parts Department supplies distributors fitted with a manual valve (14), 2nd assembly (lengthened by 14 mm). In all cases, this distributor must be fitted by removing the stop bolt (B).

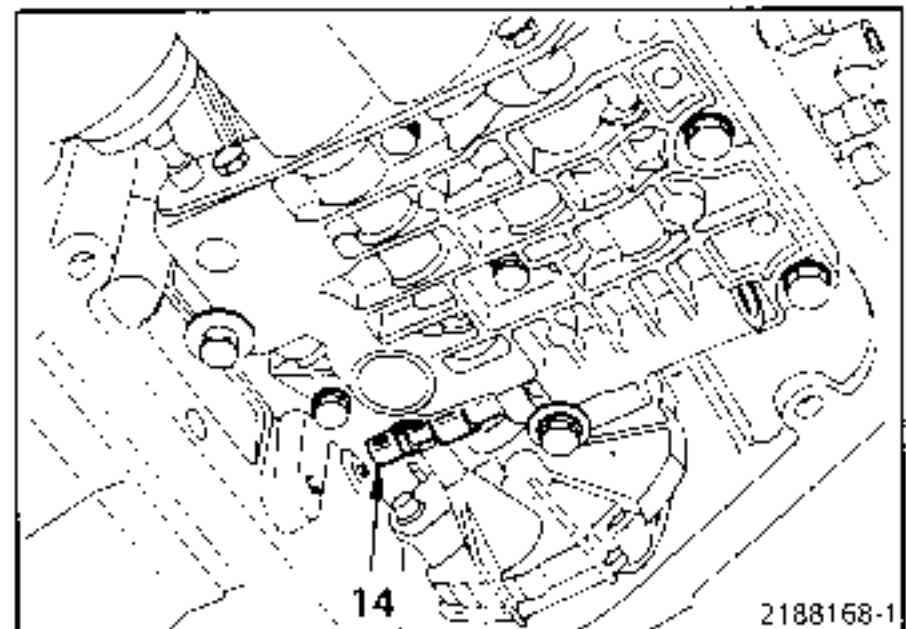

Refit the sump with a seal which must be in perfect condition.

Top up the oil level and check the oil pressure.

DISMANTLING - REASSEMBLY

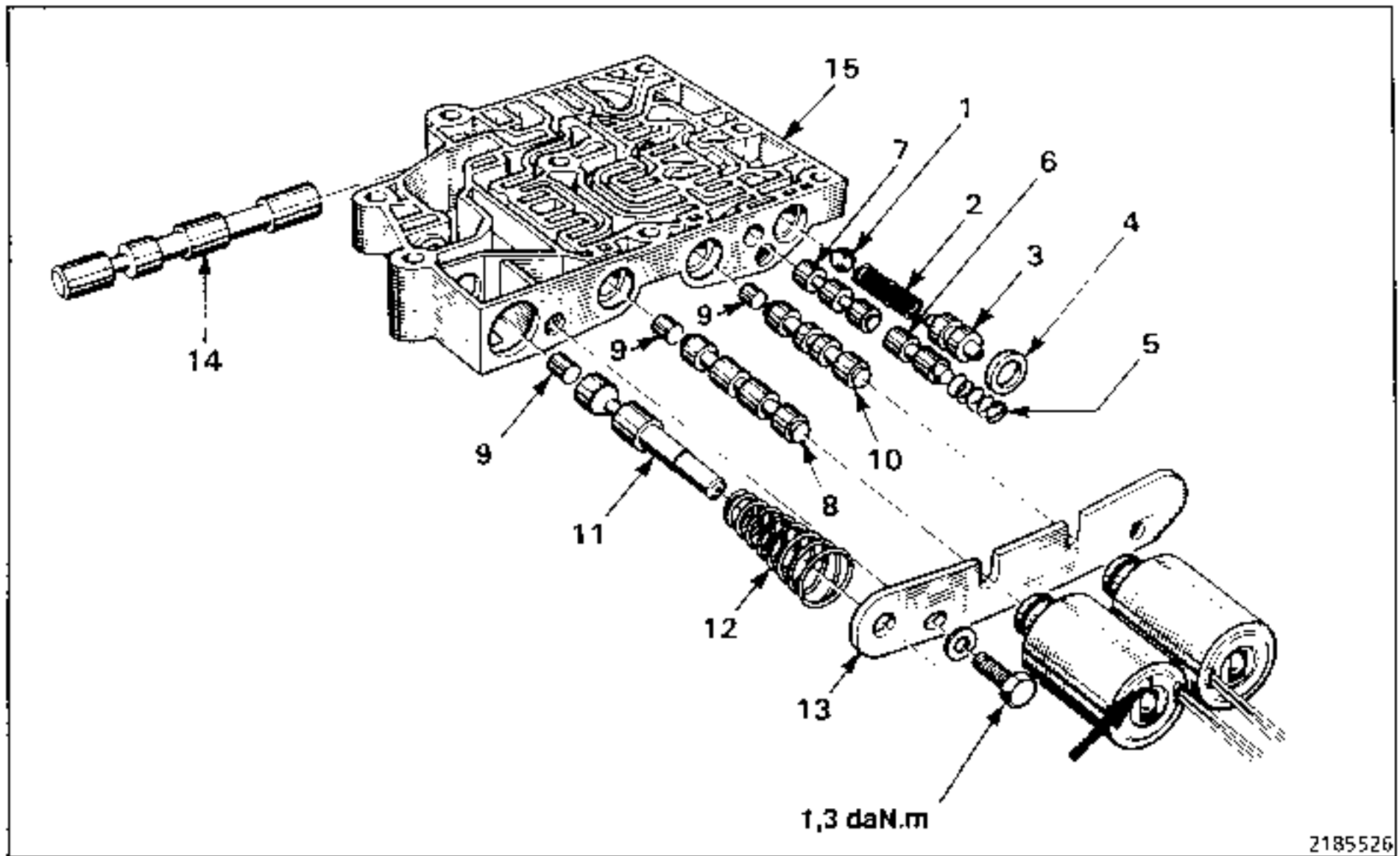

- 1 VLP ball
- 2 VLP spring (medium)
- 3 Pressure limiting valve (VLP)
- 4 VLP seal
- 5 VS spring (small)
- 6 Sequence valve (VS)
- 7 Sequence valve (VS)
- 8 1st gear valve (VP1)
- 9 Plungers
- 10 2nd gear valve (VP2)
- 11 Pressure regulating valve (VRP)
- 12 VRP spring (large)
- 13 Cover plate
- 14 Manual valve (VM)
- 15 Hydraulic unit

Plungers (9) are all identical.

Valves (3, 7, 8, 10) are symmetrical.

Valve (6) is not symmetrical.

2185526

Dismantle the hydraulic distributor in a clean, dust-free location.

DISMANTLING - REASSEMBLY

DISMANTLING

Progressively remove the two mounting bolts for the cover plate (13). Take care not to lose the spring (12).

Remove the other components by turning the unit and the manual valve over (14).

CLEANING

Use:

- WHITE SPIRIT,
- lint-free cotton wool for wiping out,
- compressed air to thoroughly blow out all the channels.

CHECKS

If any of the valves are scratched or worn, the complete hydraulic distributor must be replaced.

All the valves must move freely with no points of resistance.

Seal (4) and the seals for the solenoid valves must be in perfect condition.

REASSEMBLY

Lubricate all the parts and refit according to the exploded diagram.

IMPORTANT: valve (6) (with the larger end) should be at the small spring end (5).

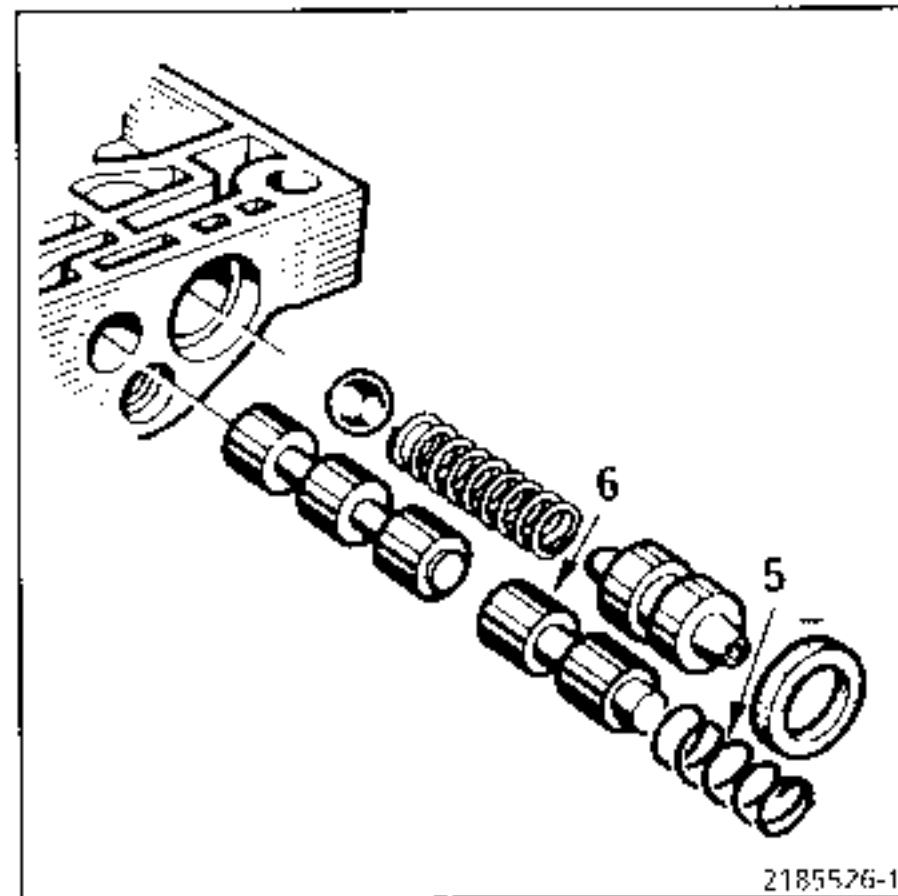

Fit the plate (13) with the two bolts and fit the solenoid valves marked (1) at the pressure regulating valve end (V.R.P.).

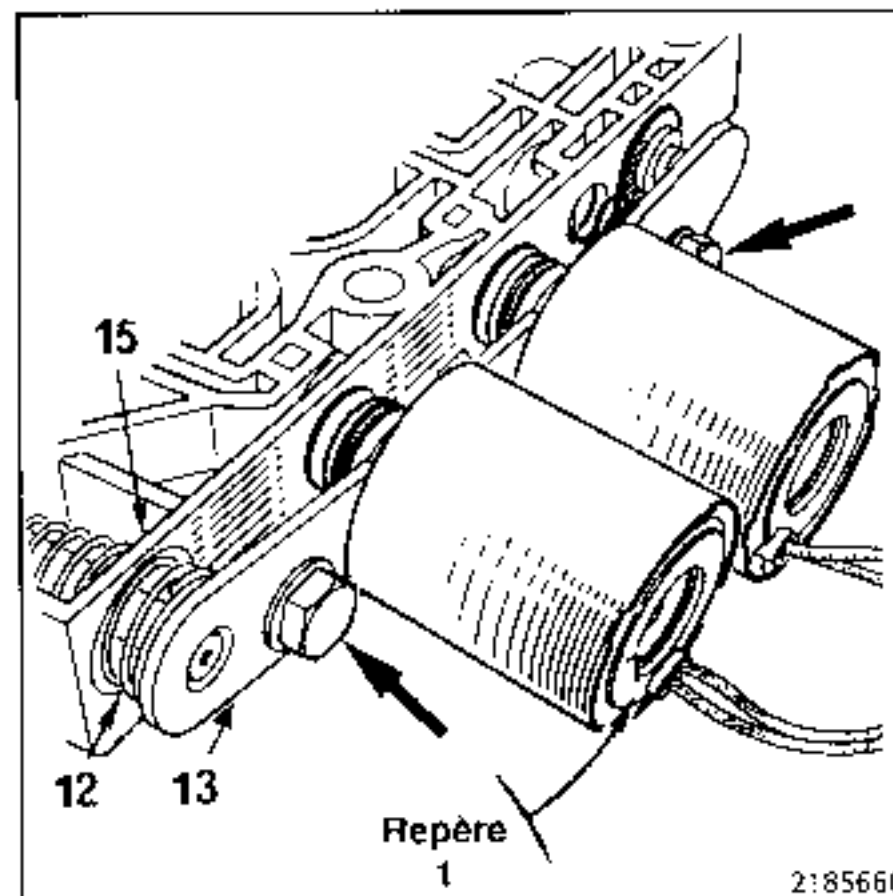

Progressively tighten the cover plate (13) so that the last coil of the spring (12) is not trapped between the plate (13) and the unit (15) and torque tighten to 1.3 daN.m.

Check that all the valves move freely.

The solenoid valves, depending on how they are supplied, allow the movement of the gear change valves (V.P.1, V.P.2.) in the hydraulic distributor which determine the changes of the gears.

TIGHTENING TORQUES (in daN.m) 	
Distributor mounting bolt	0.9
Sump mounting bolt	0.6
Cover plate mounting bolt (retains solenoid valves)	1.3

REMOVAL - REFITTING

REMOVAL

The hydraulic distributor must be removed to remove the solenoid valves (see section "Hydraulic distributor").

Slacken the two bolts until the solenoid valves may be released.

TAKE CARE NOT TO LOSE SPRING (12)

Before refitting, check:

- the seal (J) is in perfect condition,
- the O rings (T), the solenoid valves and the sealed connector are in perfect condition,
- the balls move freely and the solenoid valve channel is clean.

REFITTING

Lubricate the solenoid valves and fit the solenoid valve marked 1 at the regulation valve end (see diagram).

Progressively tighten the cover plate (13) so that the last coil of the spring (2) is not trapped between the plate (13) and the unit (15) and torque tighten to 1.3 daN.m.

Fit the pin to the sealed connector socket and re-connect the connector.

Refit the hydraulic distributor (see pages 92 to 95).

Top up the oil level and check the oil pressure.

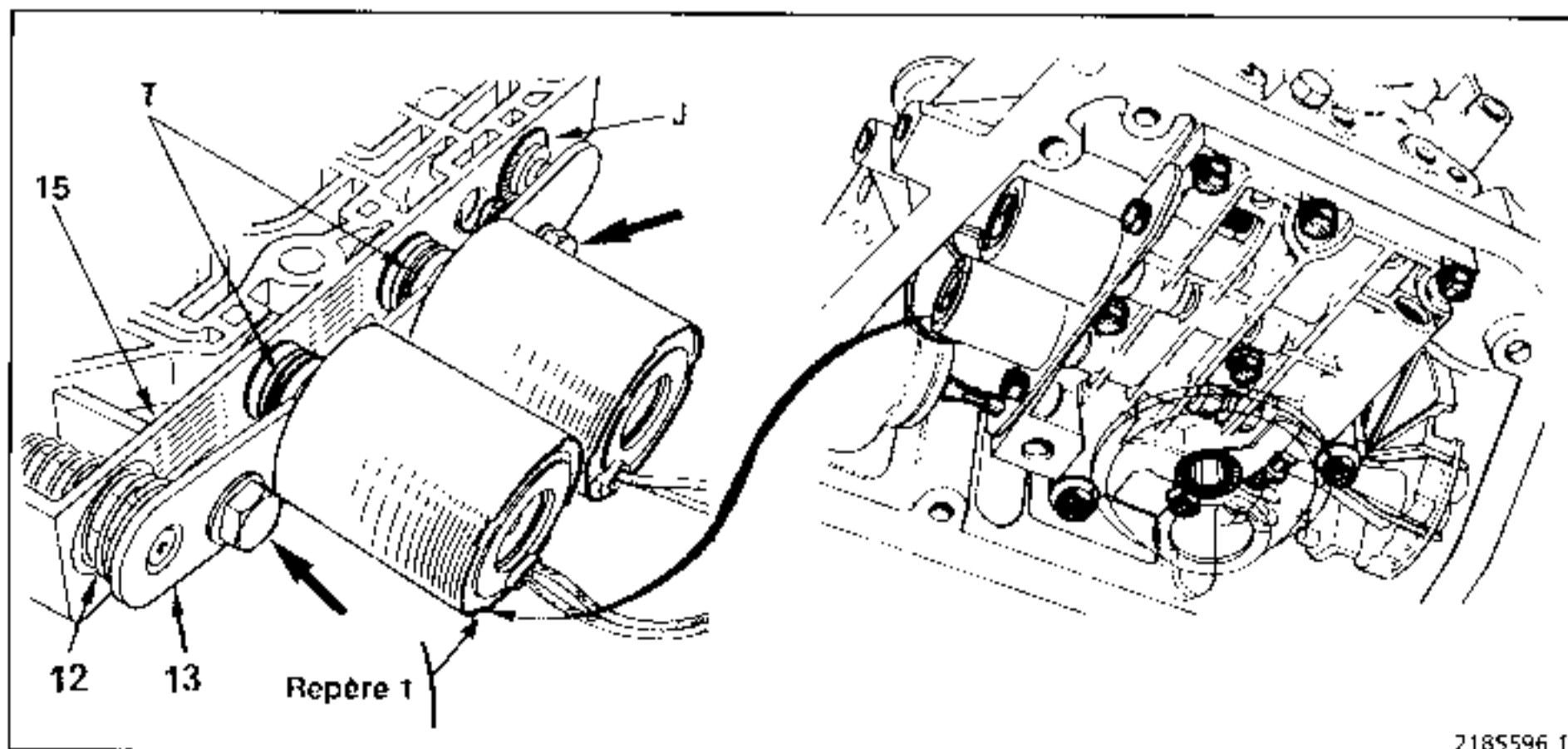

2185596 1

IMPORTANT: the vehicle will lose 1st gear if the solenoid valves are incorrectly connected.

TIGHTENING TORQUES (in daN.m)



Strainer mounting bolt	0.5
Distributor mounting bolt	0.5
Sump mounting bolt	1 ± 0.1
Control sector stop	0.3

REMOVAL

THIS OPERATION IS CARRIED OUT WITH THE LEVER IN "P".

Drain the transmission.

Remove:

- the sump,
- the strainer (bolts 1),

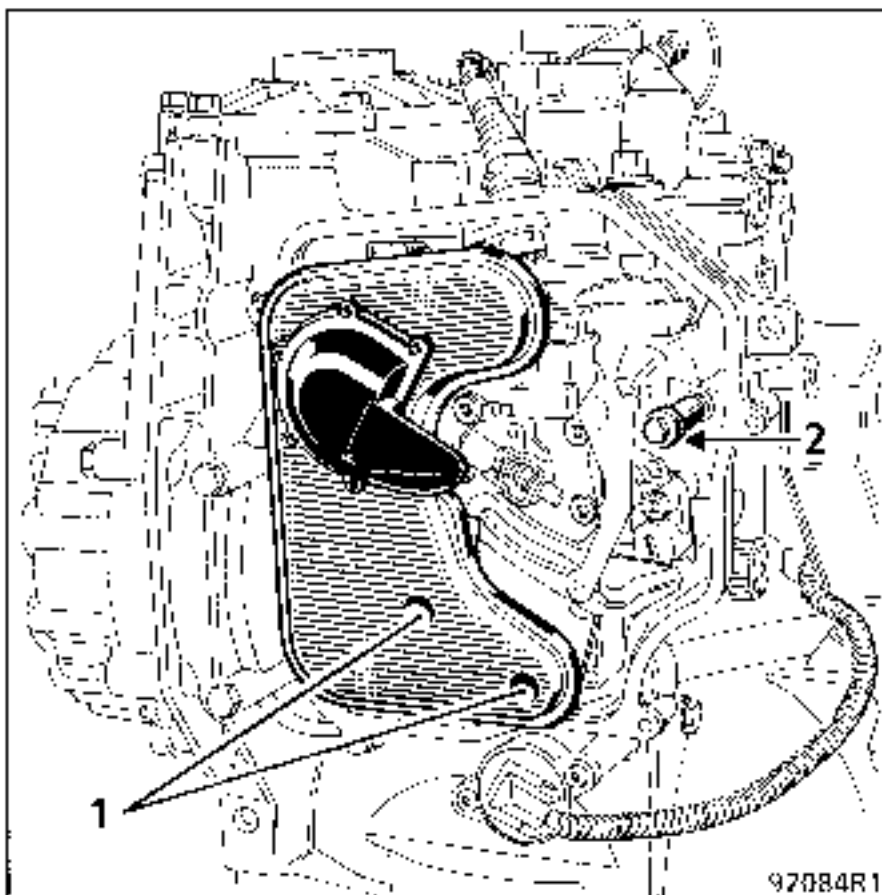

- the control sleeve adjustment key (3),
- the control sector stop (2) to allow the lever to move beyond the "Park" position.

This additional travel is needed to release the drive from the manual valve control sector.

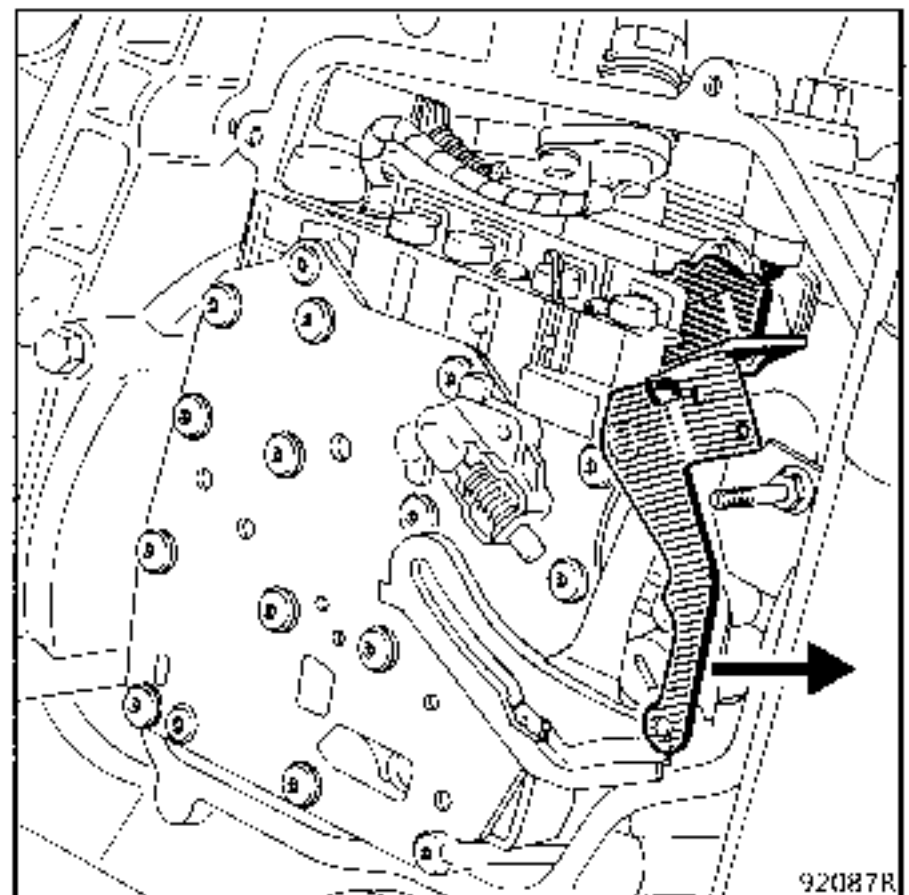
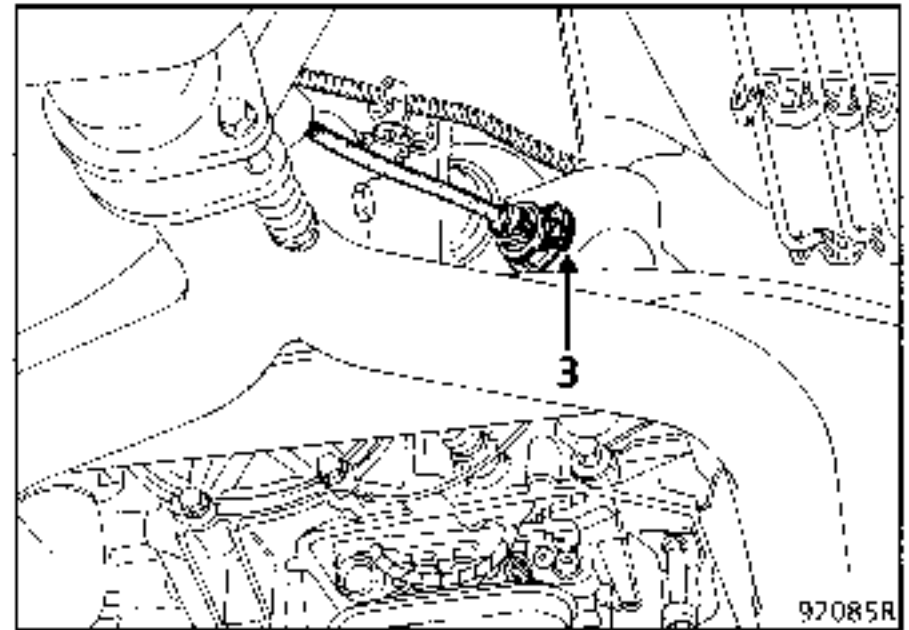

Disconnect the sealed connector cable by pressing on the locking ring.

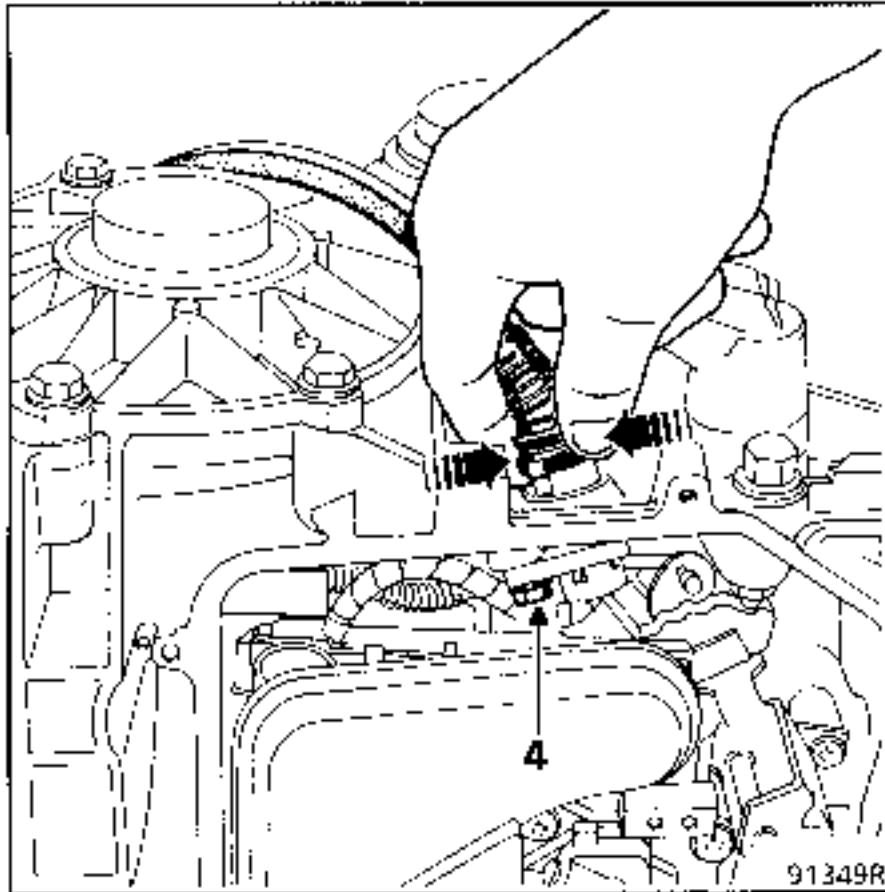

Remove the sealed connector mounting bolt (4), remove the connector and retain the O ring.

Remove the 16 bolts mounting the distributor to the housing. The bolts marked (*) remain in place and secure the cover plate to the distributor.

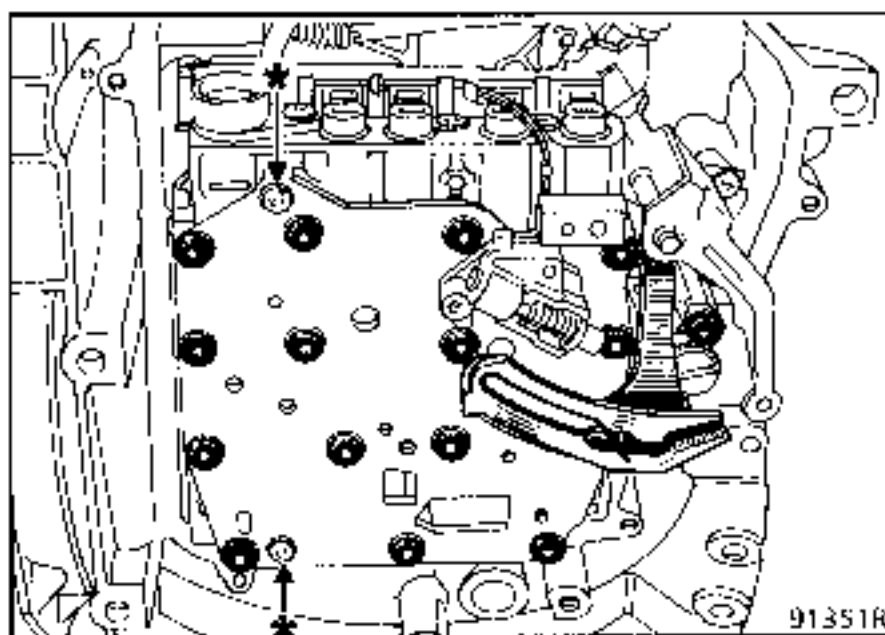

Release the hydraulic distributor, releasing the modulating solenoid valve (5) from the housing.

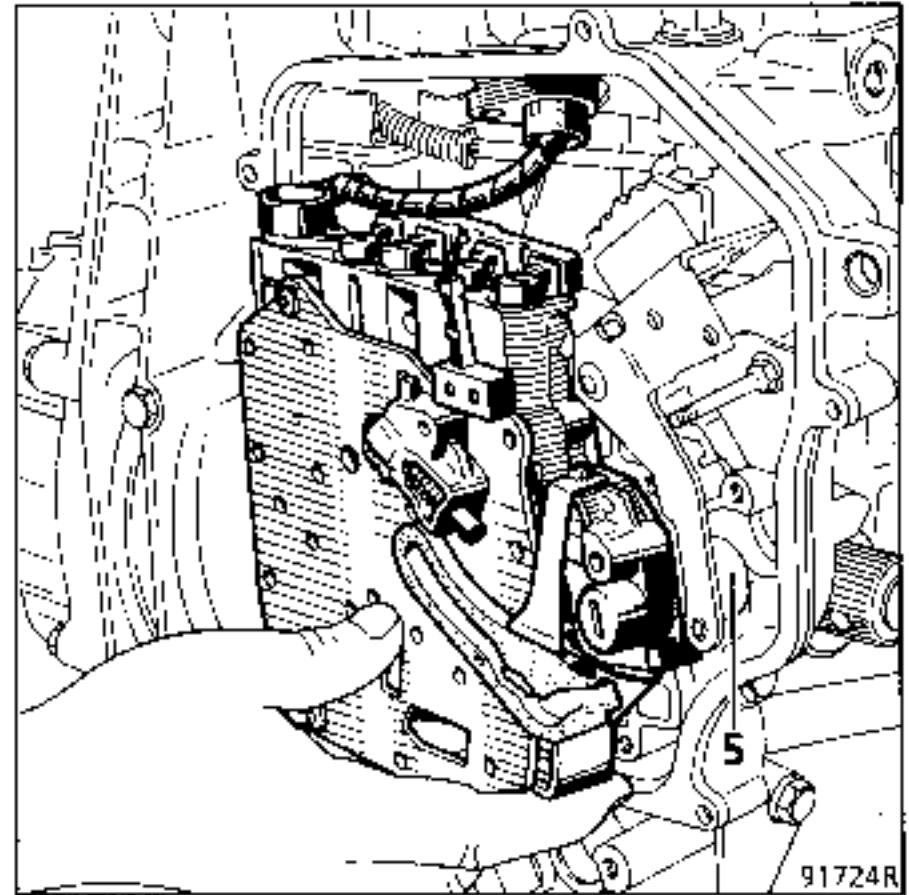

Ensure the inserts (6) and the filter (7) remain in position in the hydraulic network on the housing.

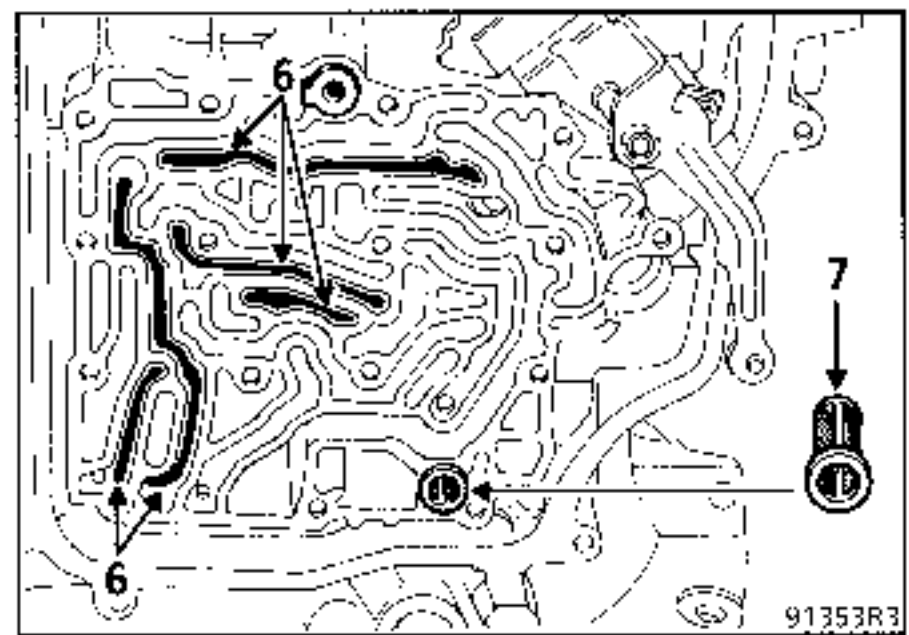

When removing the hydraulic distributor, do not remove the manual valve or the control sector.

REFITTING

Ensure the supply pipe for F1 (8) the filter for the modulating solenoid valve (7) and the inserts in the network (6) are present and check the selector lever is in the excess travel position (9).

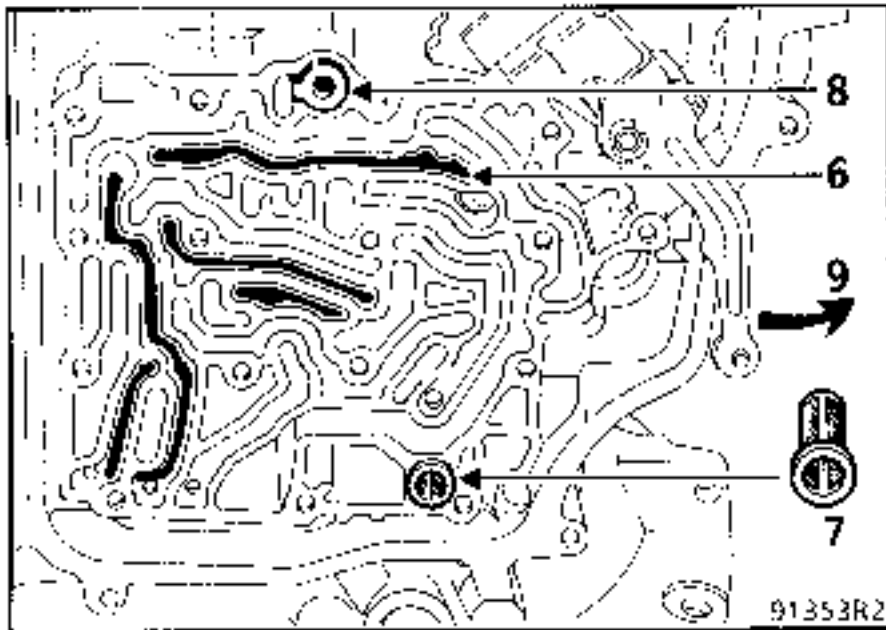

Fit the hydraulic distributor into position.

Ensure the modulating solenoid valve (5) is refitted correctly.

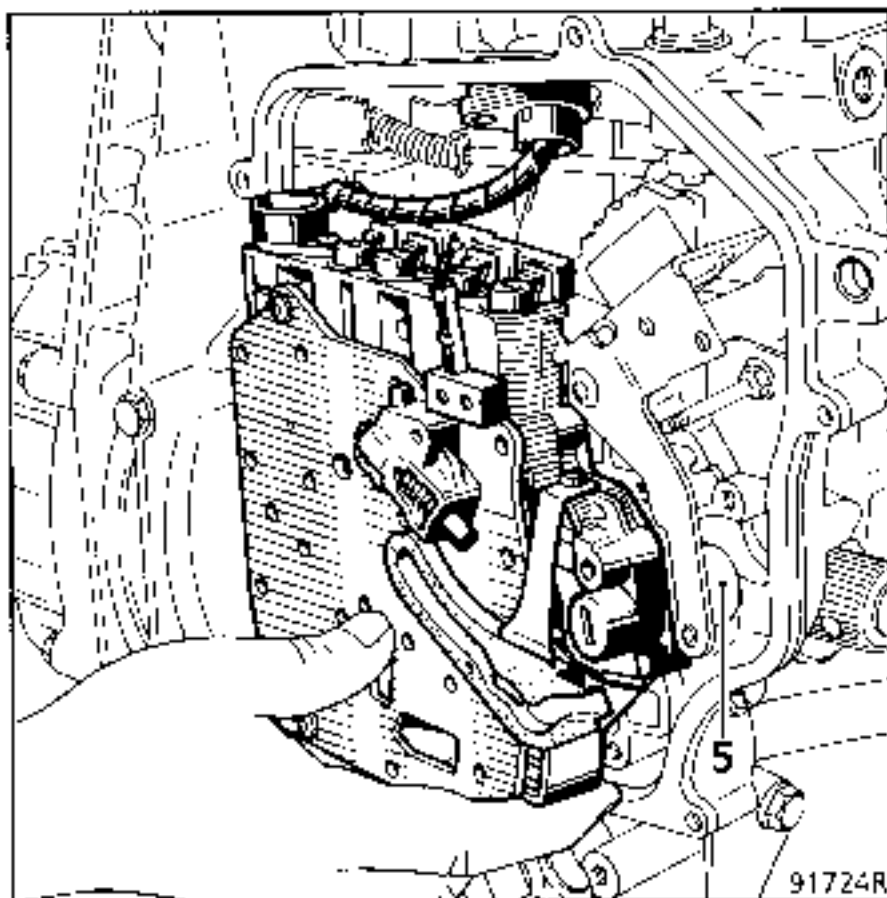

Fit the 16 distributor mounting bolts on the housing and torque tighten them to 0.5 daN.m.

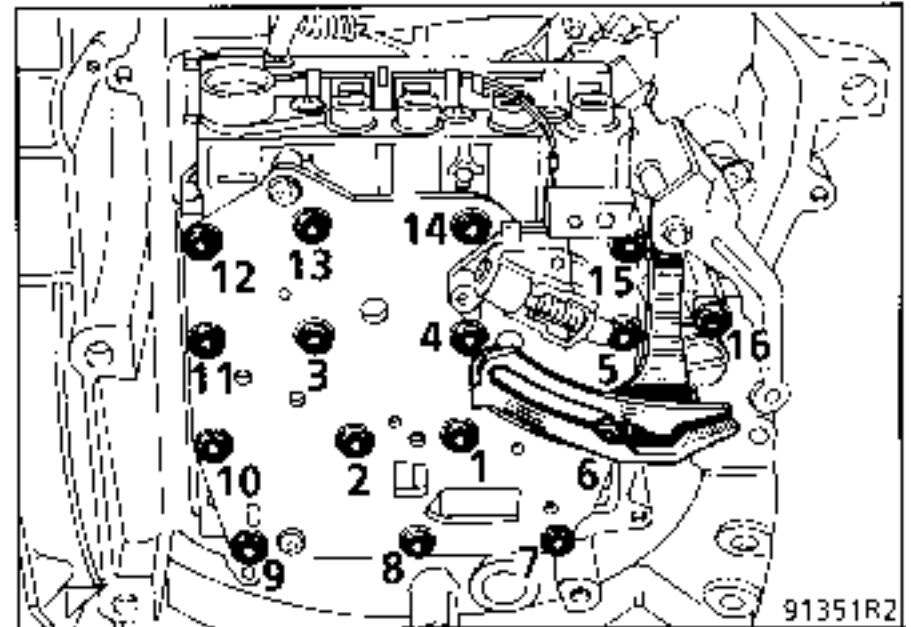

Engage the control lever in the manual valve sector and return to the "Park" position.

Fit the control sector stop; tighten it to 0.3 daN.m.

Fit a new strainer and seal; tighten the bolts to a torque of **0.5 daN.m (1)**.

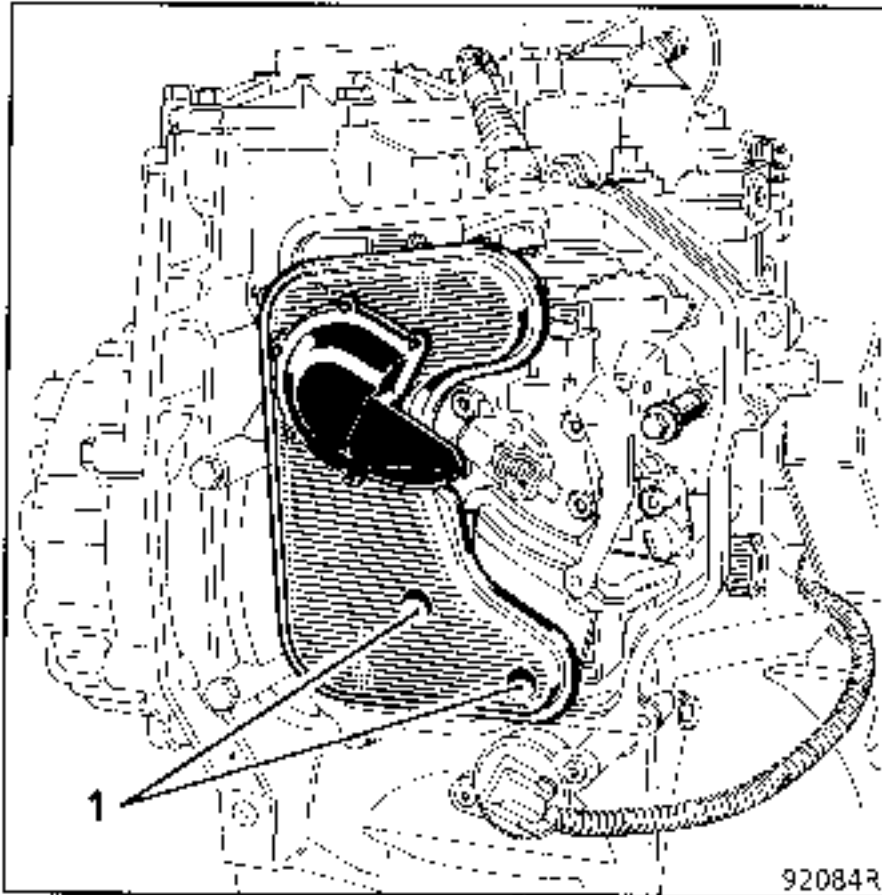

Adjust the gear control and refit the cable locking key (see Technical Note for the vehicle).

Fit the sump (ensure the seals, the level plug and the magnet are all present and in good condition).

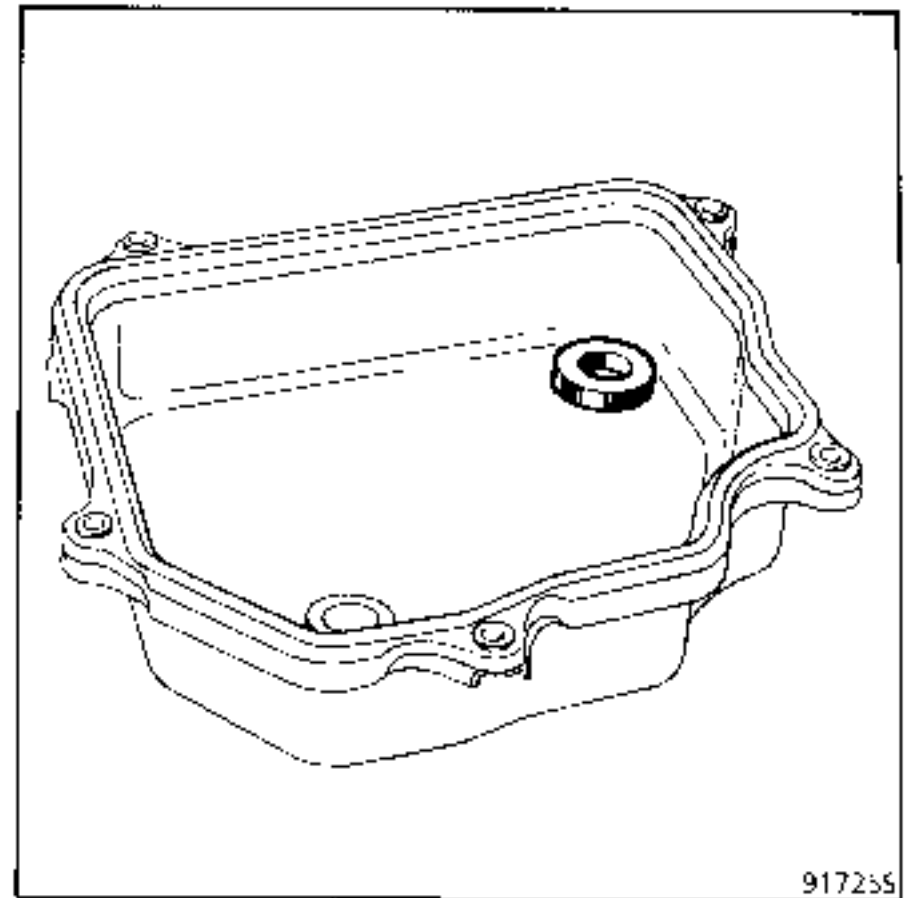

Tighten the sump mounting bolts to a torque of **1 ± 0.1 daN.m**.

Fill the transmission with oil.

Check the level (see section "Filling").

NOTE : each time the hydraulic distributor is replaced or removed, renew the filter for the modulating solenoid valve, the strainer and its seal.

TIGHTENING TORQUES (in daN.m)



Sump mounting bolt	1 ± 0.1
Strainer mounting bolt	$0.5 \begin{smallmatrix} + 0.1 \\ 0 \end{smallmatrix}$
Hydraulic distributor mounting bolt	$0.5 \begin{smallmatrix} + 0.1 \\ 0 \end{smallmatrix}$

REMOVAL

This operation is carried out with the lever in position "P" (Park).

Drain the transmission.

Remove the sump (see section "Replacing the strainer").

Remove the strainer (bolts 1).

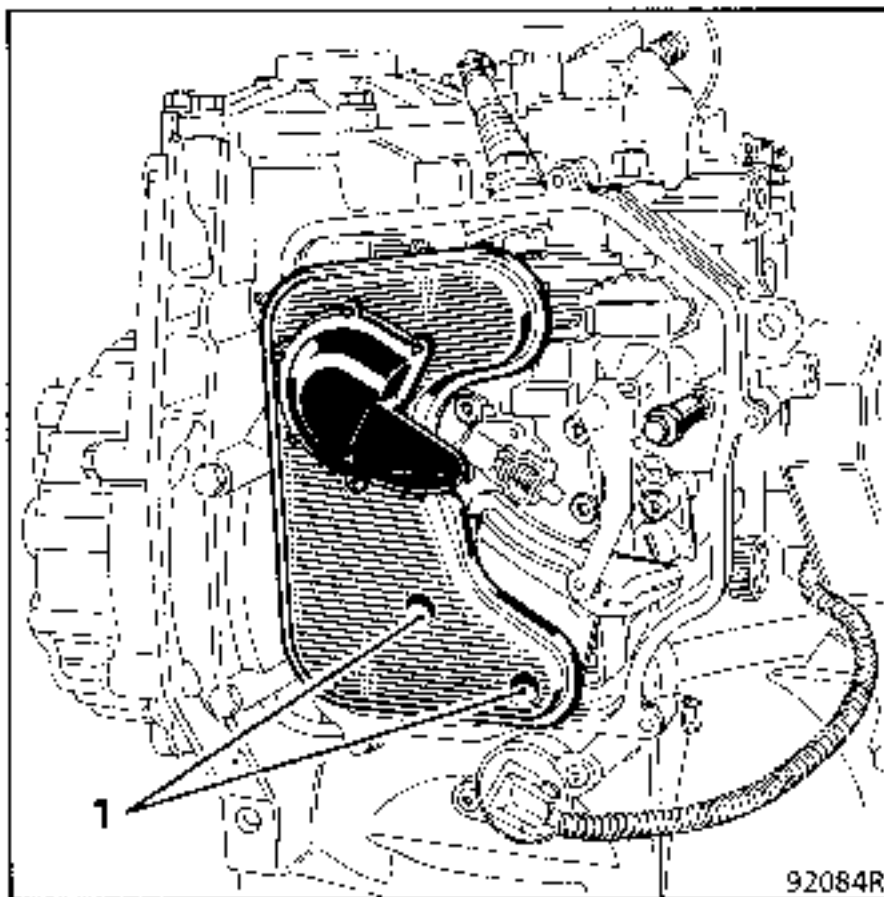

Remove the gear control cable.

Remove the selector (2) to allow the lever to move beyond the "Park" position.

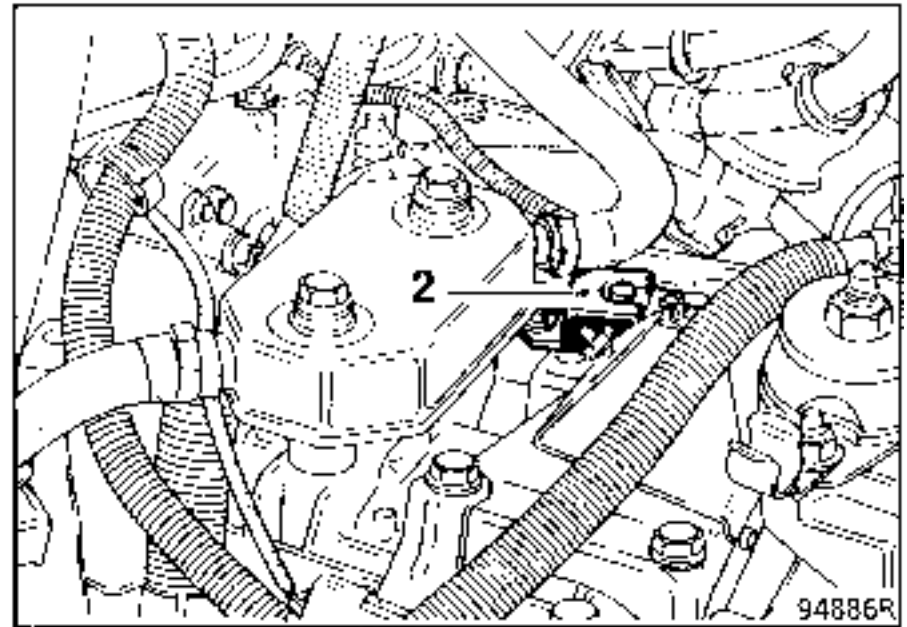

This additional travel is needed to release the drive from the manual valve control sector.

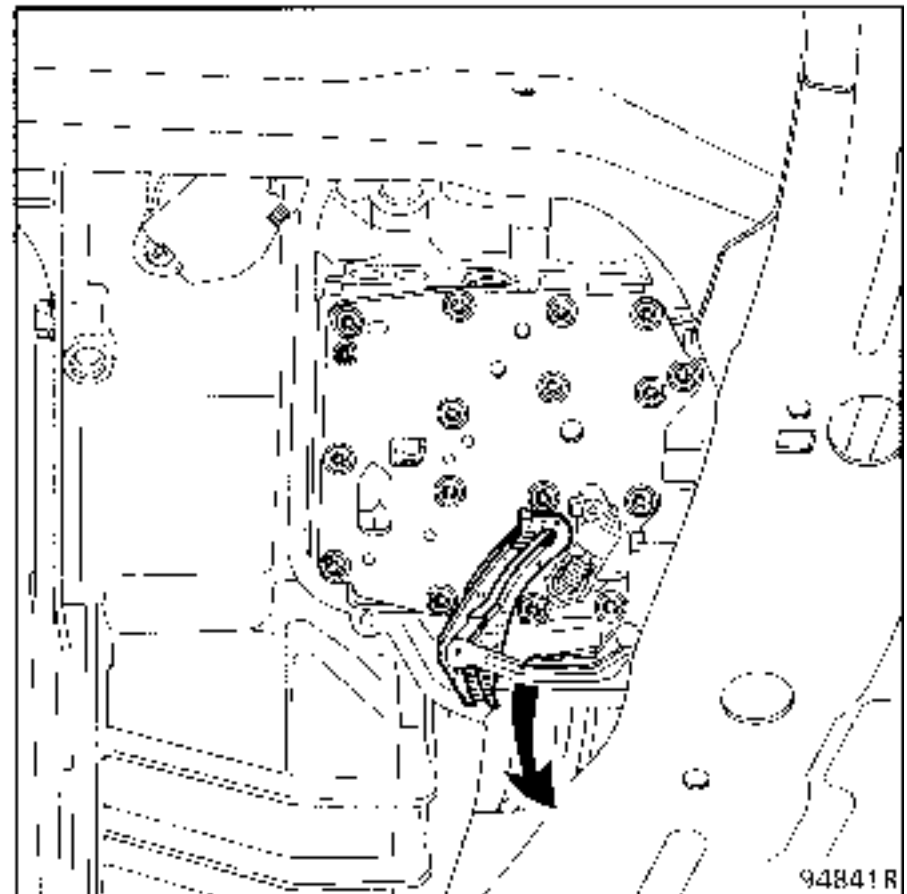

Disconnect the sealed connector cable by pressing on the locking ring.

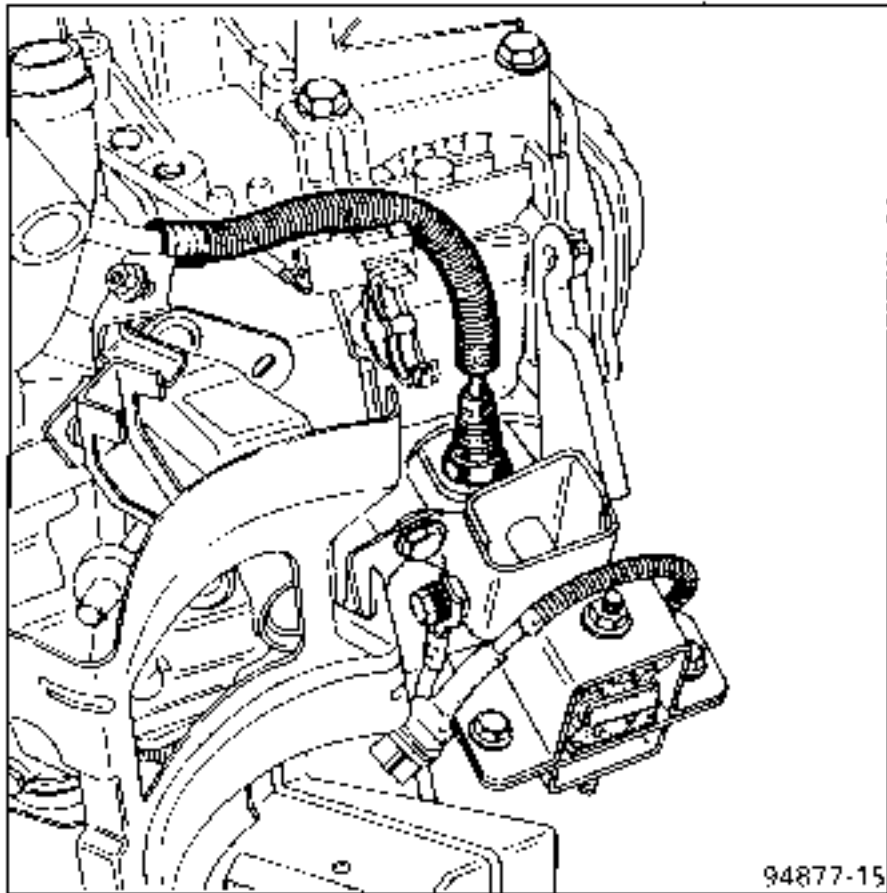

Remove the sealed connector after removing the bolt (3).

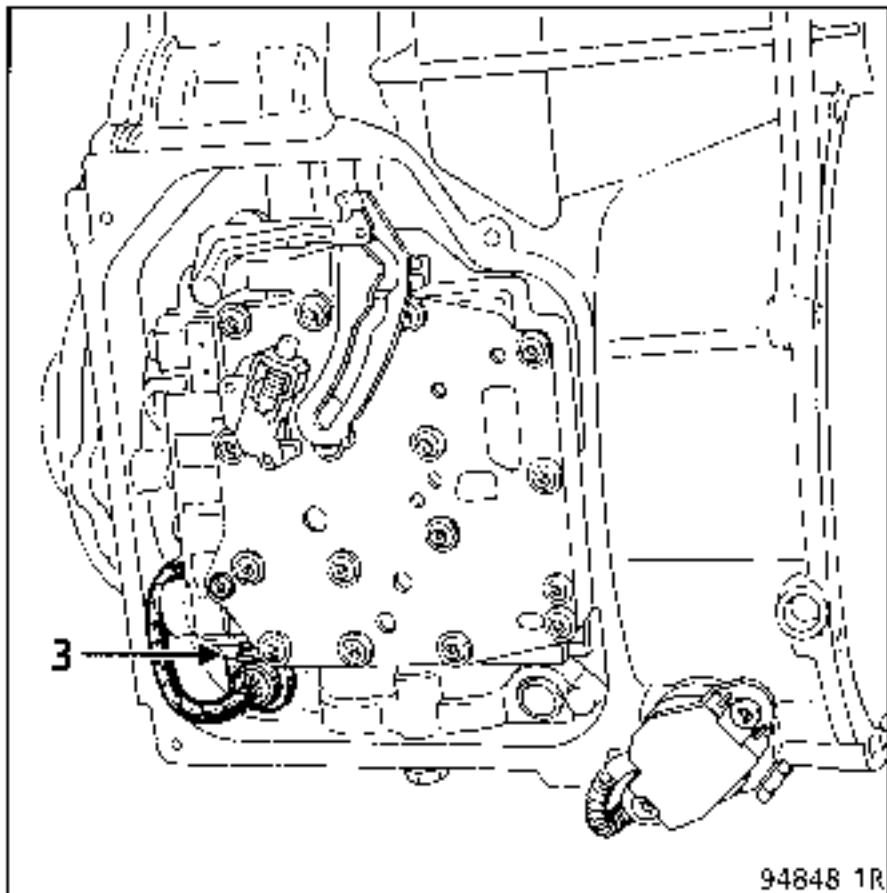

Remove the manual valve selector (4), releasing first at (A) then at (B).

Remove the manual valve from the hydraulic distributor.

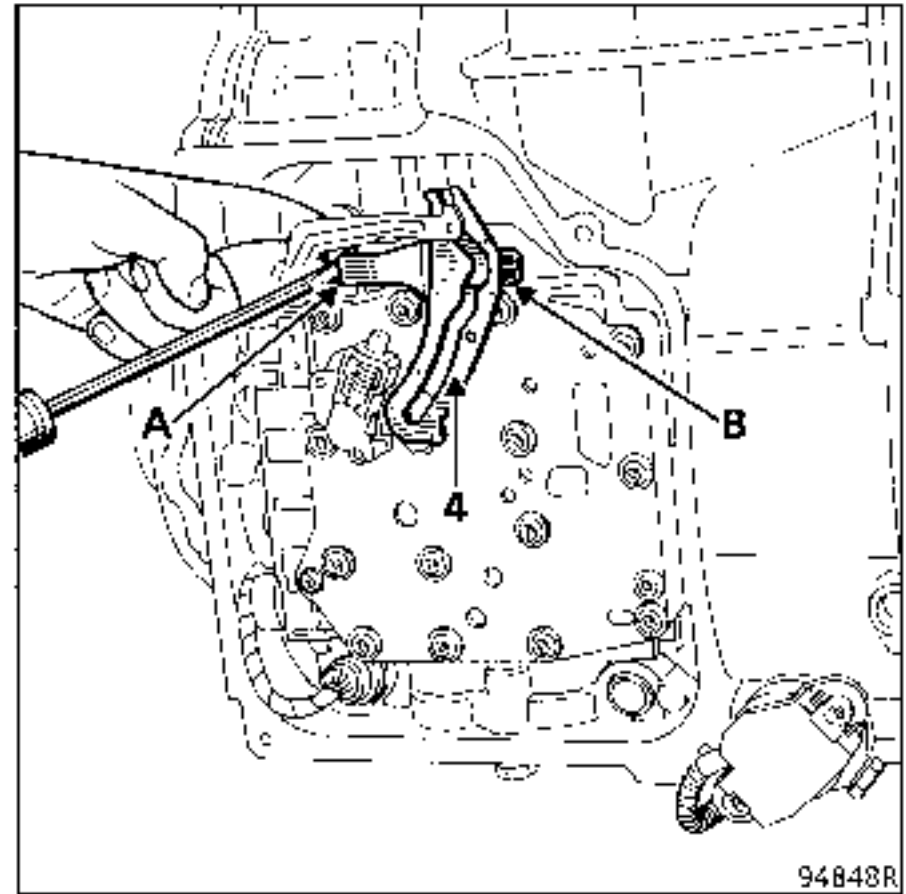

Remove the 16 bolts mounting the distributor to the housing. The bolts marked (X) remain in place and secure the cover plate to the distributor.

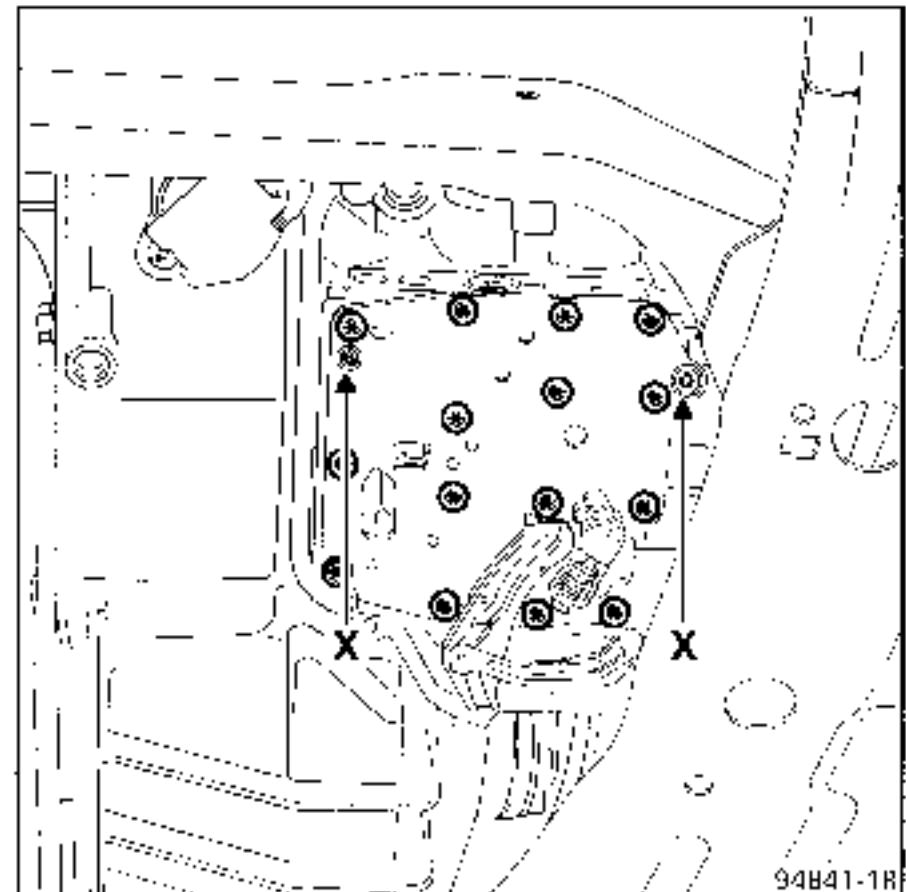

Push the gear control selector to the stop and release the hydraulic distributor, removing the modulating solenoid valve from the housing (5).

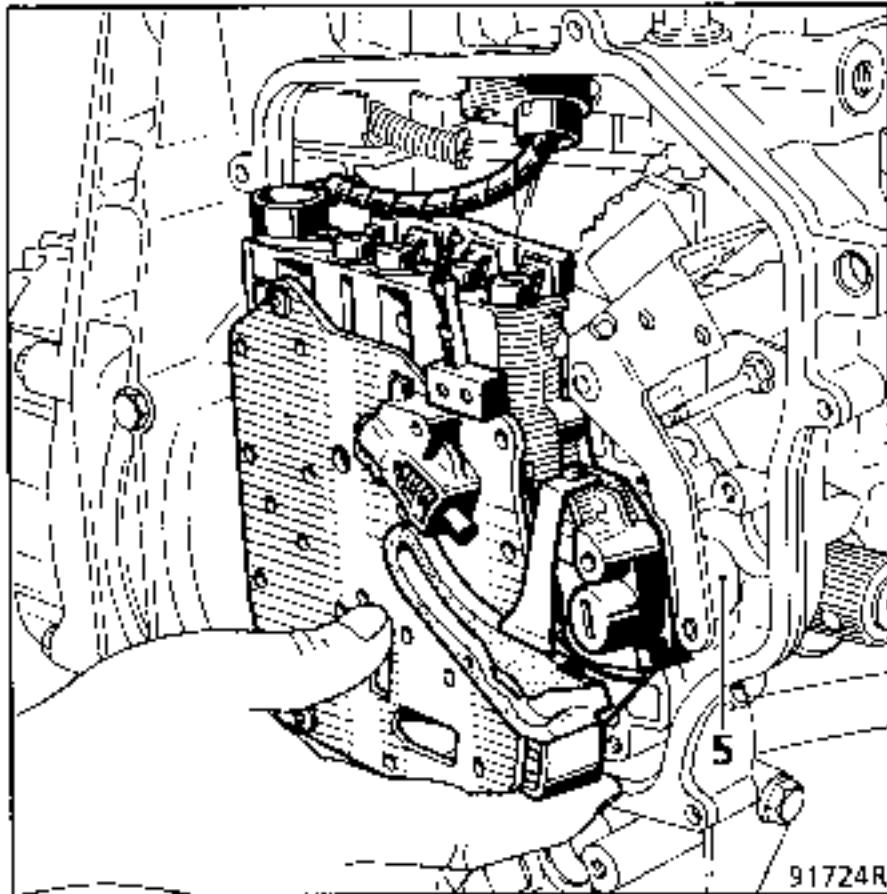

Ensure the inserts (6) and the filter (7) remain in position in the hydraulic network on the housing.

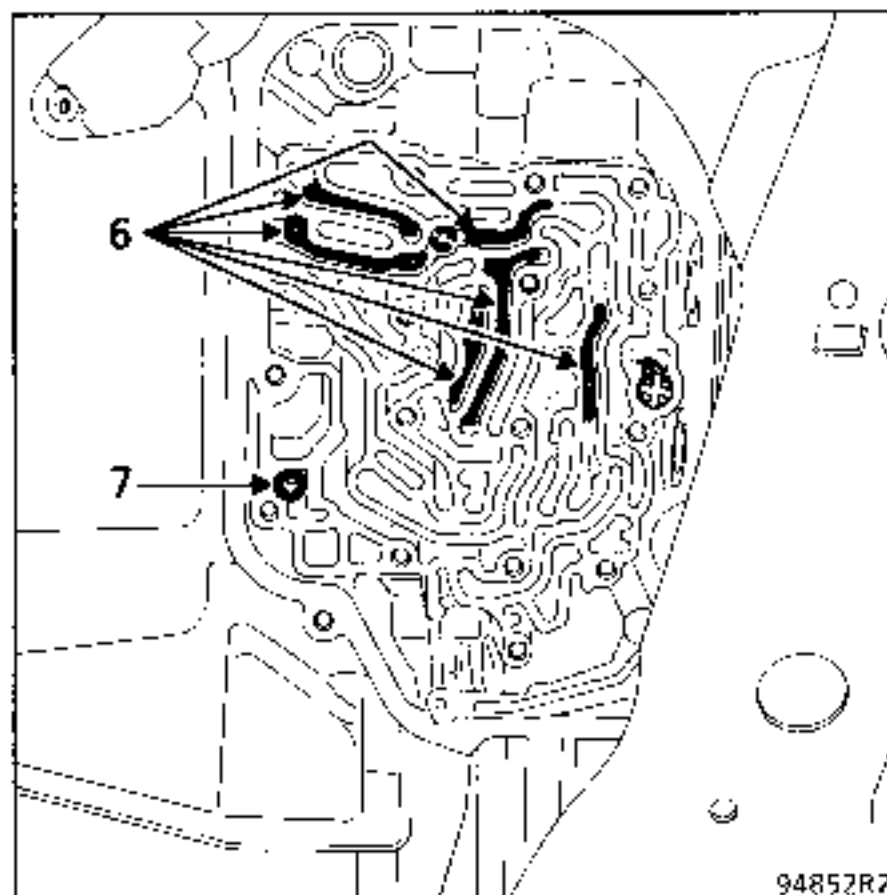

REFITTING

Ensure the supply pipe for F1 (8) the filter for the modulating solenoid valve (7) and the inserts in the network (6) are present.

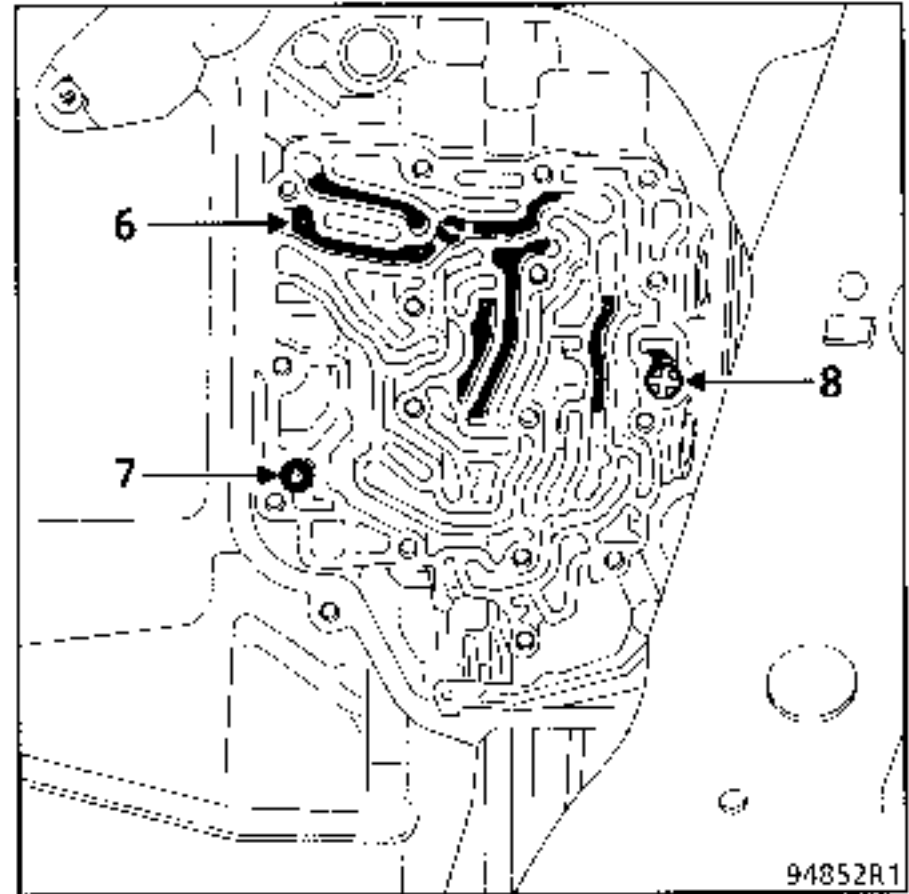

Fit the hydraulic distributor.

Push the gear control selector to the stop, taking care to correctly fit the modulating solenoid valve into the housing (5).

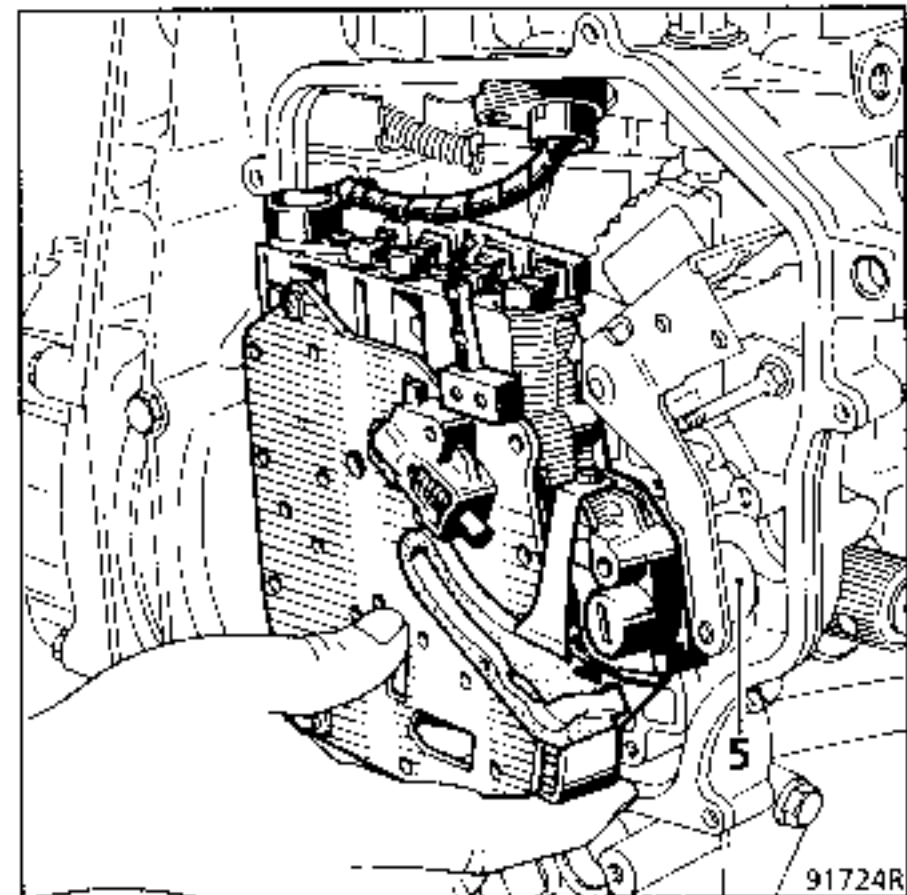

Fit the 16 distributor mounting bolts on the housing and torque tighten them to **0.5 daN.m** in the order shown.

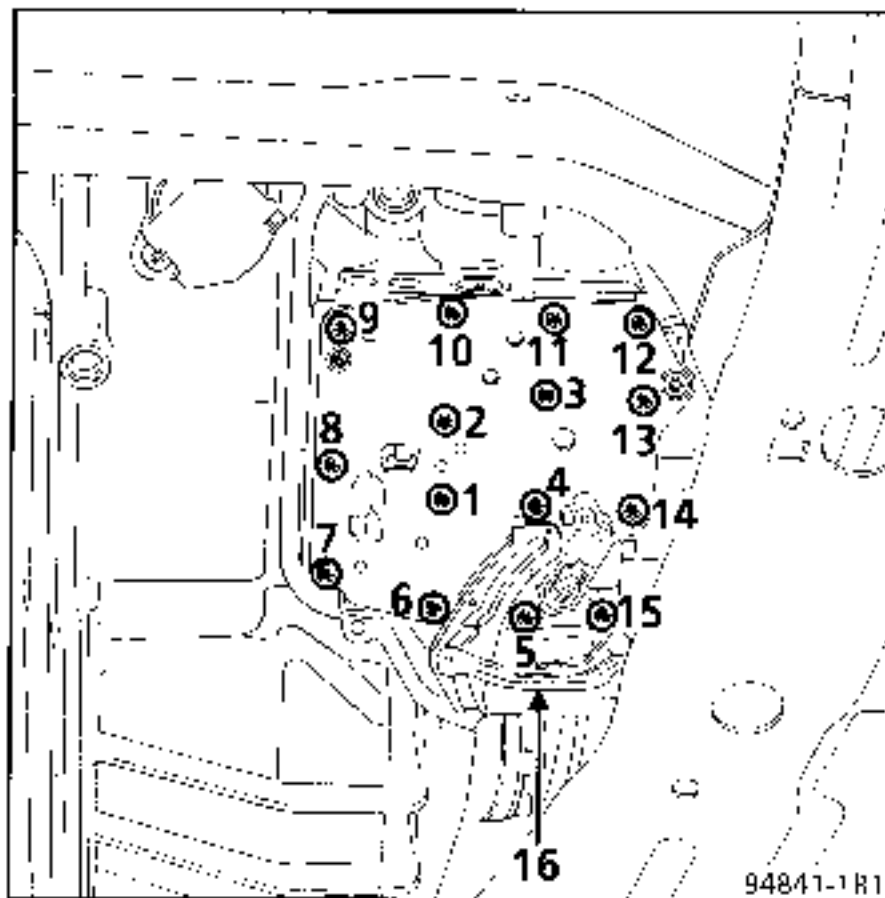

Fit the manual valve and the selector (4) fitting it first at (A) then at (B).

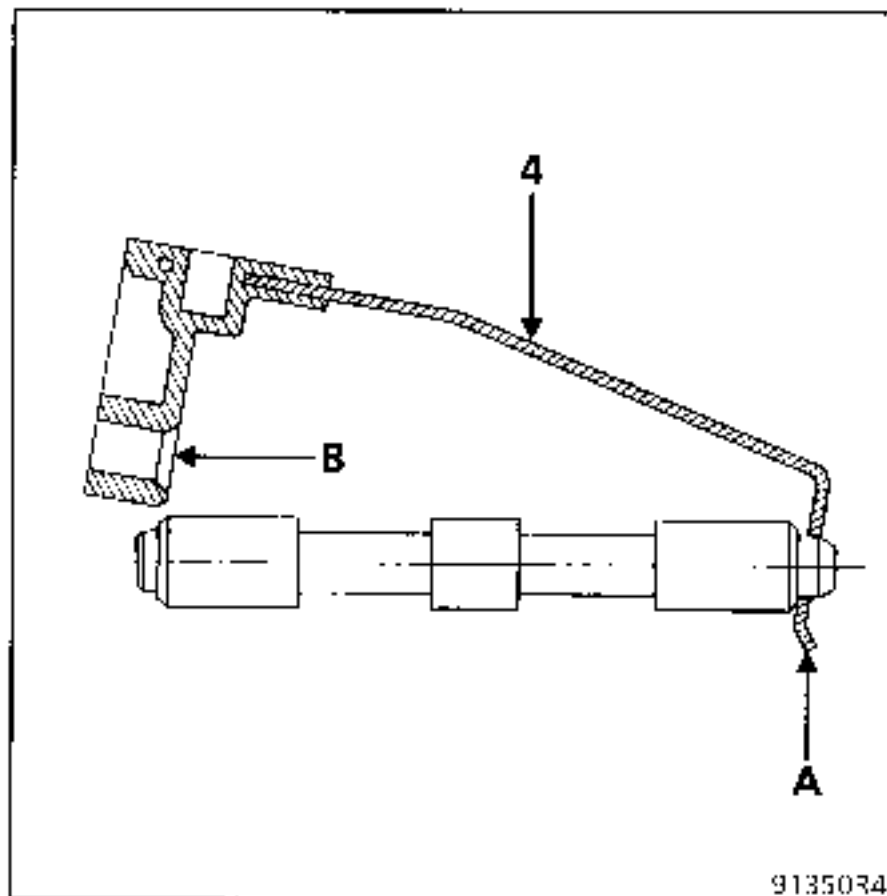

Refit the sealed connector with its O ring and bolt (3).

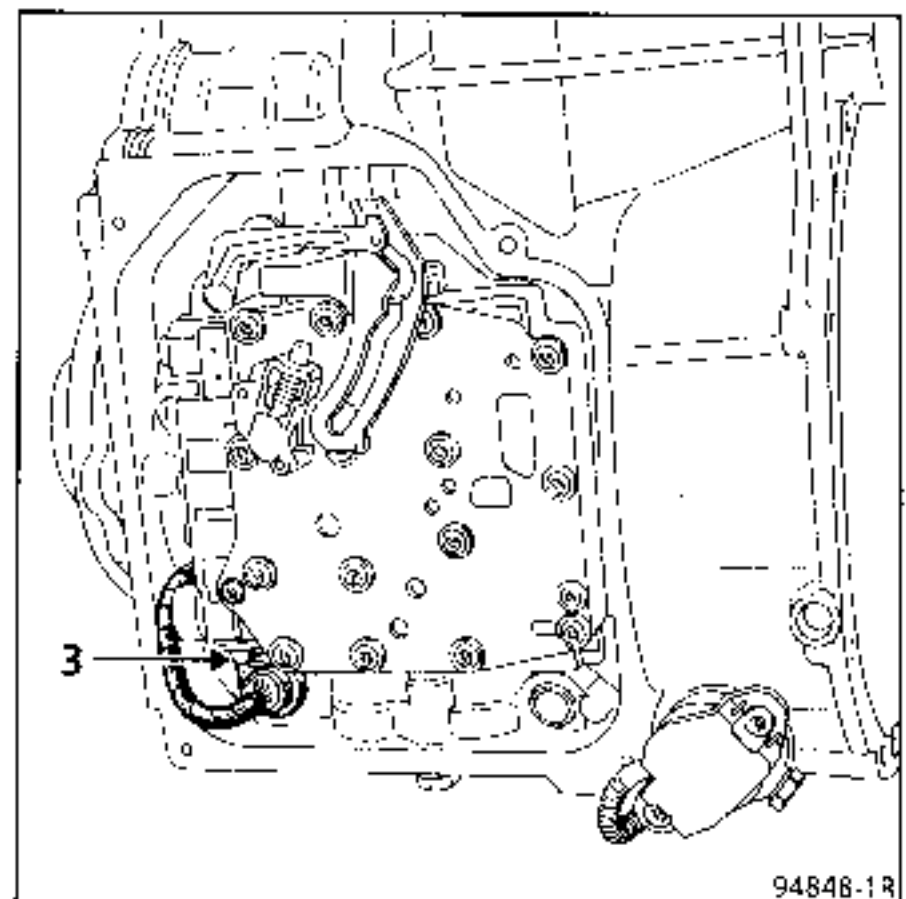

Fit a new strainer and seals.

Torque tighten to **0.5 daN.m**.

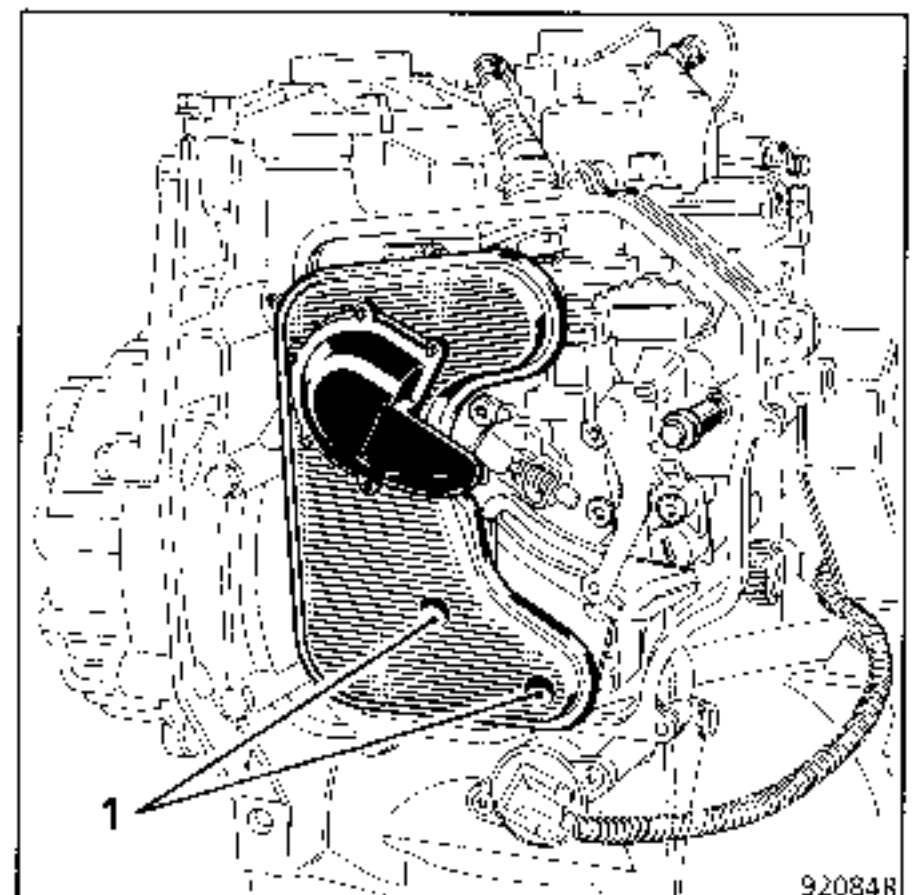

Fit the sump (check the seals are in good condition and the magnet is present).

Tighten the bolts to a torque of **1 daN.m**.

Refit the automatic transmission (see section "Replacing the strainer").

Reconnect the sealed connector.

Refit the gear selector.

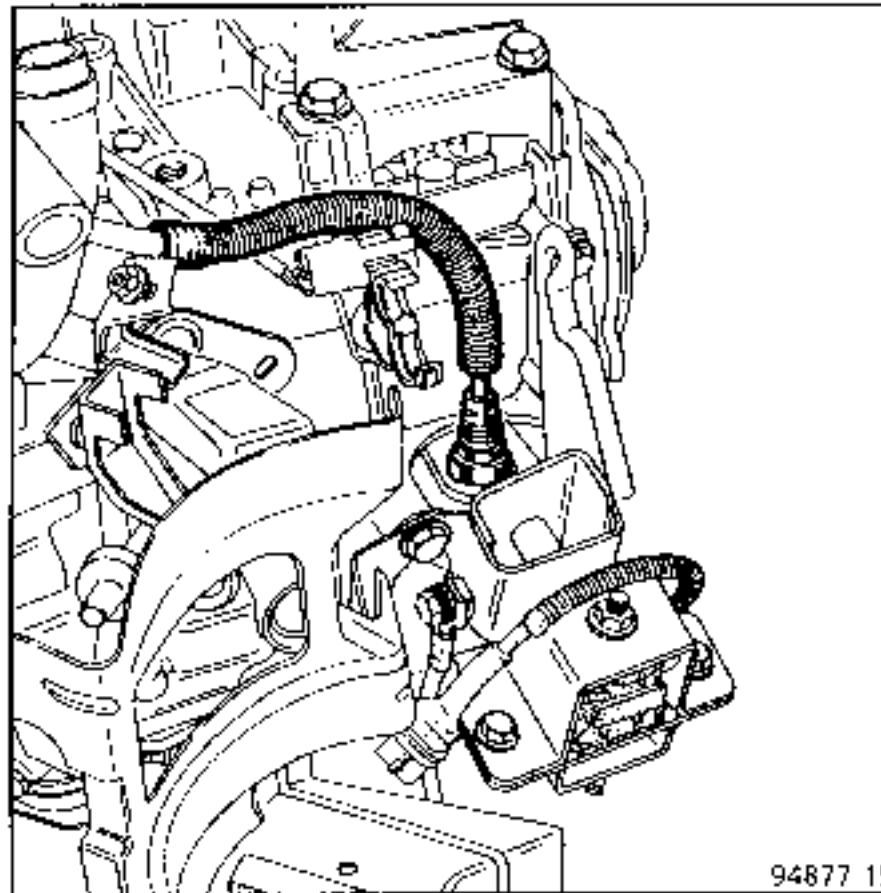

Refit the control cable.

Fill the transmission with oil and check the level.

NOTE : each time the hydraulic distributor is replaced or removed, renew the modulating solenoid valve filter.

TIGHTENING TORQUES (in daN.m)



Wheel bolts	9
Shock absorber mounting nut	20
Track rod end nut	4

Drain the final drive section then, depending on the side in question:

- remove the front wheel,
- remove the driveshaft roll pin using tool **B.Vi. 31-01**.
- disconnect the track rod end (tool **T.Av. 476**).

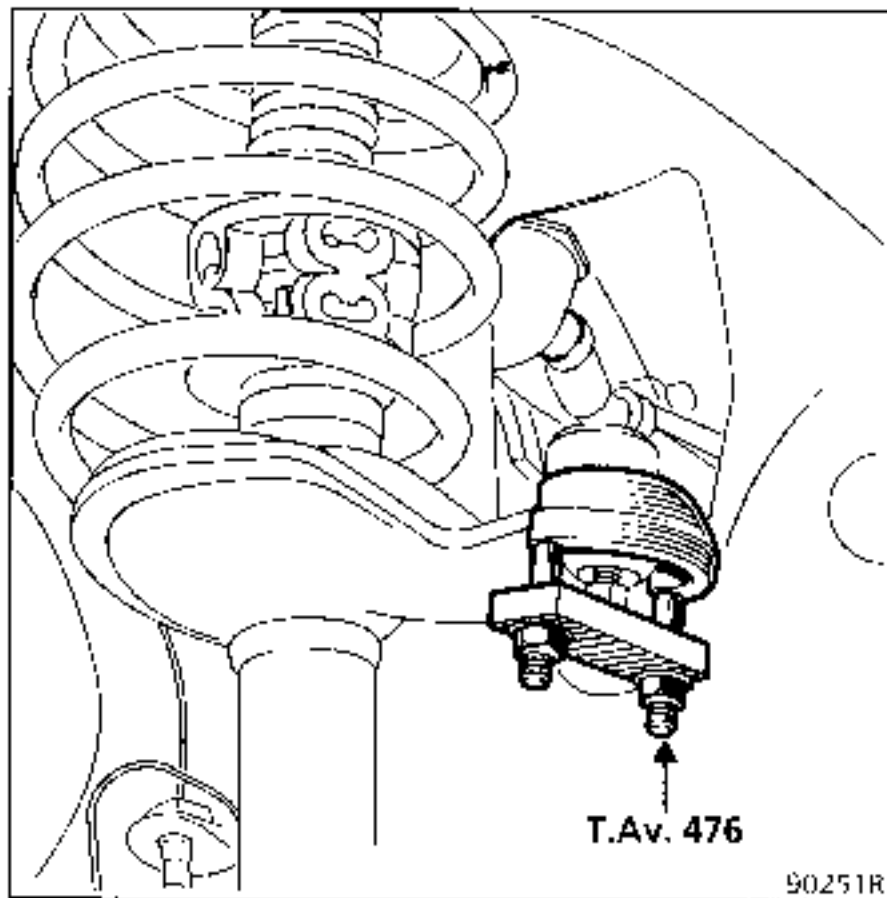

On the right or left hand side, slacken the lower shock absorber base mounting bolts (2) and remove the upper bolts (1).

NOTE : the bolts have a splined section so a mallet must be used to remove them.

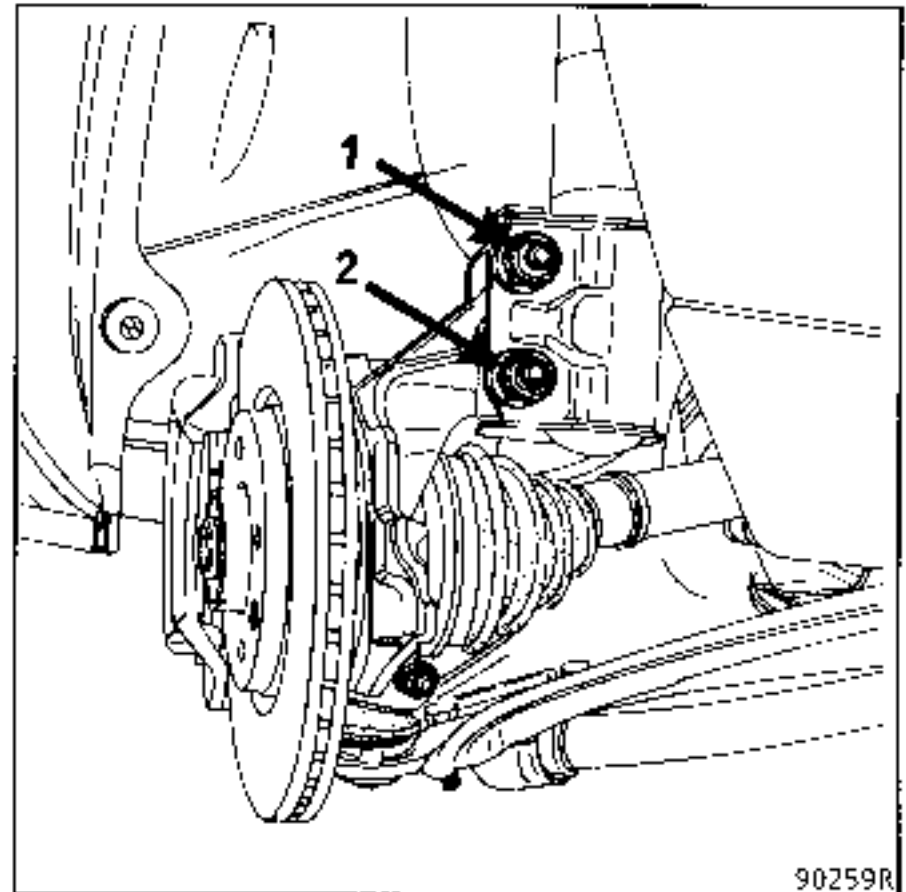

Tilt the stub axle carriers and release the driveshaft from the sunwheel.

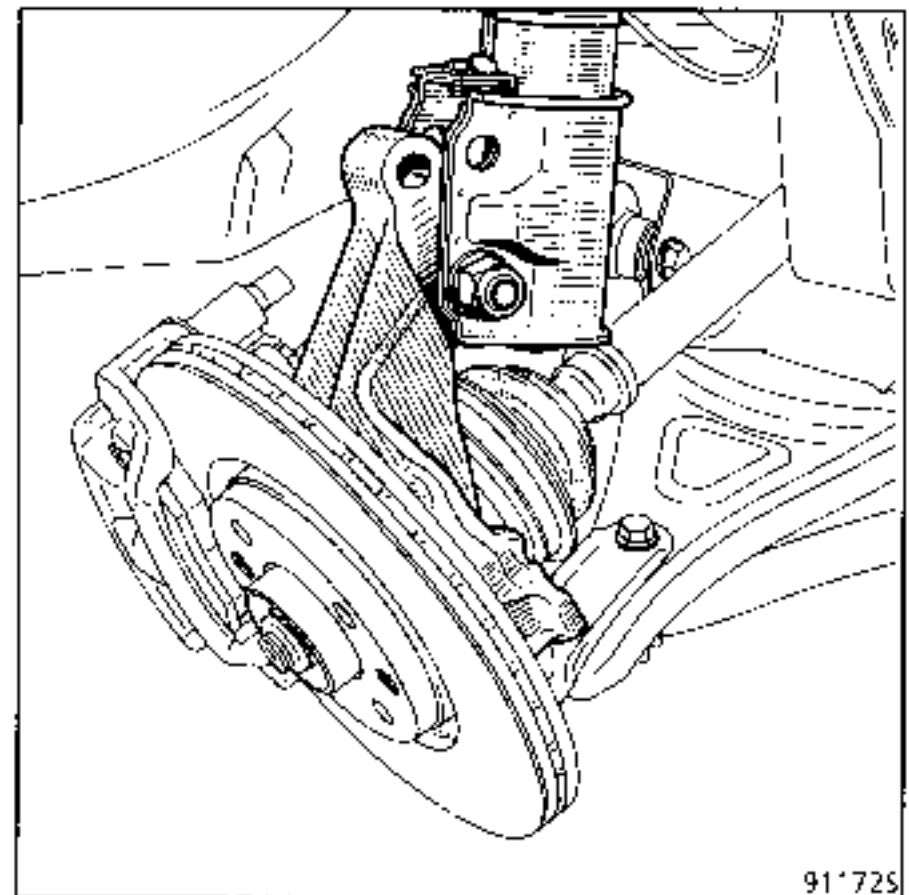

SPECIAL TOOLING REQUIRED

B.Vi. 951 Tool for fitting differential seal

TIGHTENING TORQUES (in daN.m)



Cover plate bolt

2

REMOVAL

Remove the O rings for the sunwheels and the differential cover plate bolts.

Using a small hammer, knock the right hand sunwheel in order to remove the cover plate.

Take care not to let the differential fall during this operation.

Remove the two deflectors and the two lip seals.

REFITTING

Refit:

- the two deflectors,
- the differential,
- the cover plate with a new O ring; torque tighten the cover plate bolts.

The lip seals are refitted using tool B.Vi 951 which comprises:

- A** Tool for fitting the seal at the cover plate end.
- B** Tool for fitting the seal at the end opposite to the cover plate.
- C** Protective sleeve which must be lubricated before use.

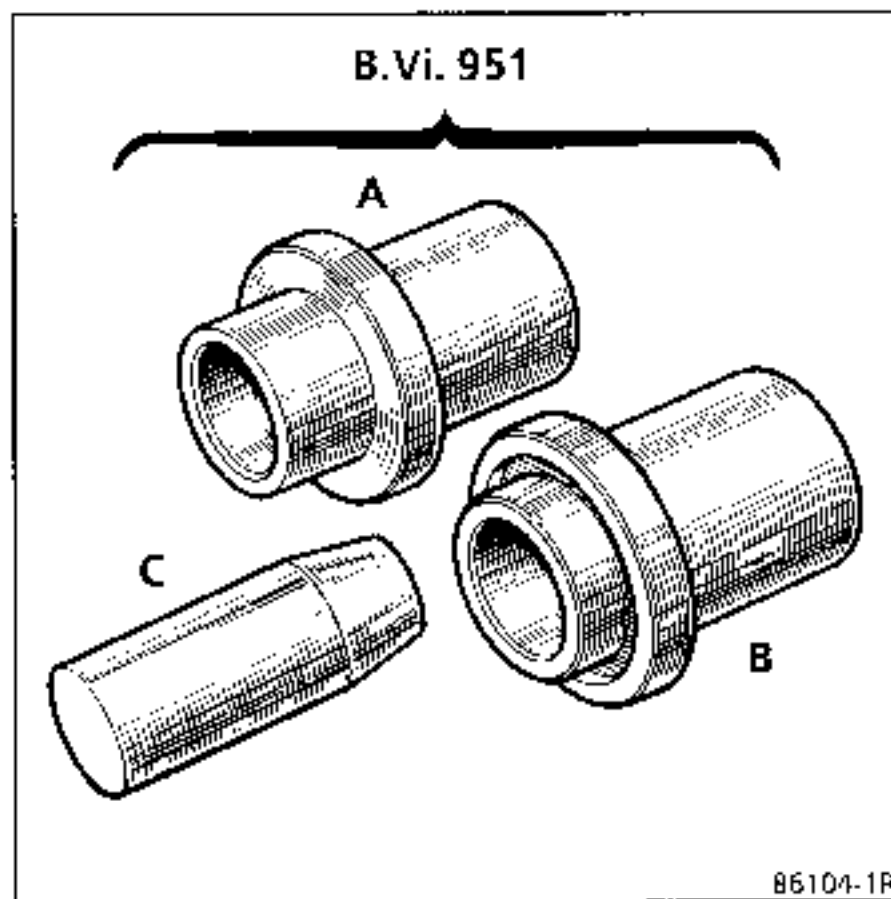

METHOD

Plate end

Fit the sleeve (C) to the sunwheel, fit the seal to the sleeve and position the seal using tool (A).

Opposite end to plate

Proceed in the same manner, but use tool (B) to position the seal.

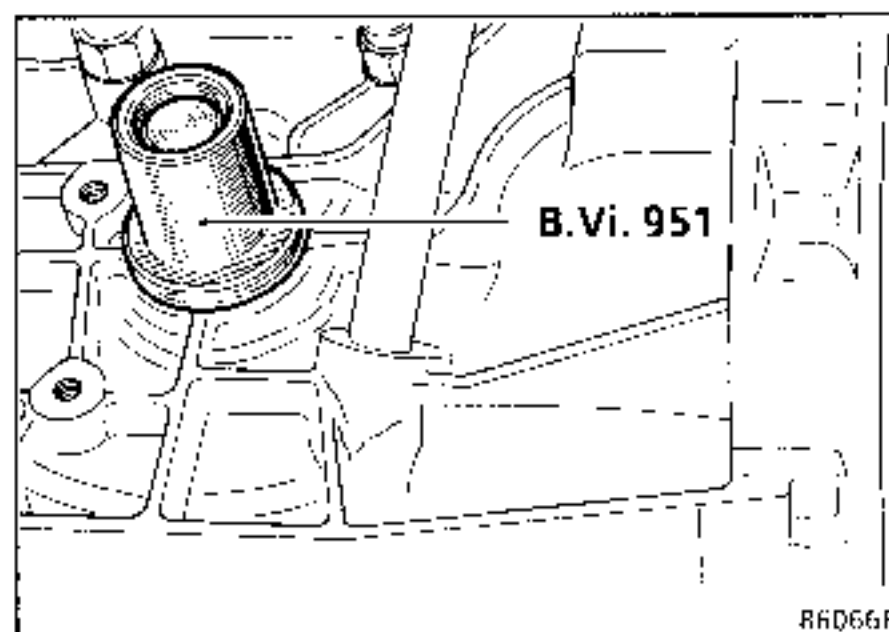

NOTE : on automatic transmissions **MJ3-800** and **801**, the right and left hand differential output seals have been modified.

Marks on the lip of each of the seals identify the right and left hand sides.

They are marked according to the outer diameter (\varnothing).

The right hand seal measures **43.7 mm**, the left hand seal measures **45.2 mm**.

This new assembly only applies to the transmissions specified above. Other transmissions have right and left hand seals which are identical, with an external diameter of **42.2 mm**.

Seals of diameter **42.2 - 43.7 - 45.2** are fitted using tool **B.Vi. 951** which positions them correctly in the housing.

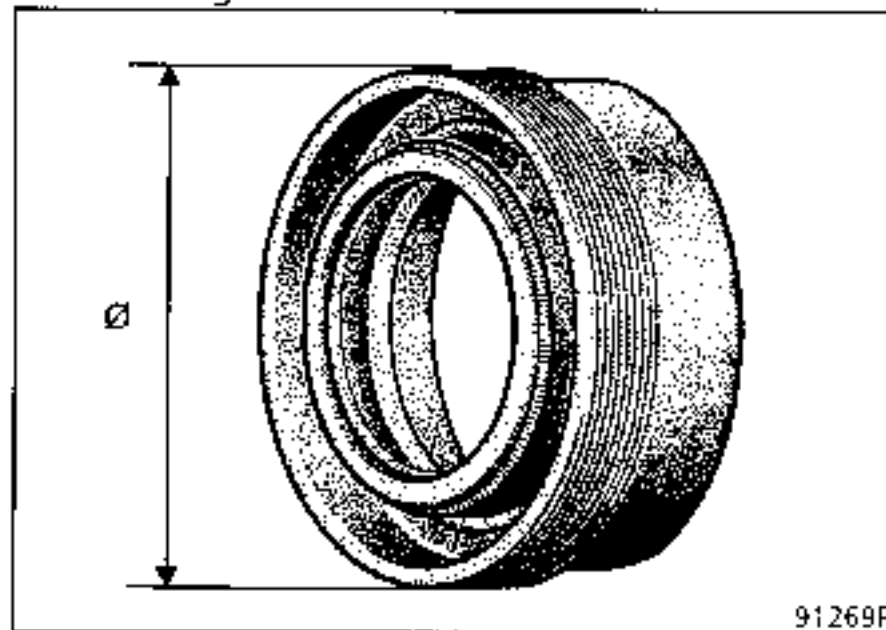

SPECIAL TOOLING REQUIRED

B.Vi. 1104	End piece for fitting left hand seal
B.Vi. 1105	End piece for fitting right hand seal

Remove the driveshaft O ring and the lip seal from the differential output using a screwdriver.

Carefully clean the sunwheel before fitting a new seal.

To fit the left hand seal, use tool **B.Vi. 1104** and push it into position until it is right up against the housing.

To fit the right hand seal, use tool **B.Vi. 1105** and its protective nose and push it into position until it is right up against the housing.

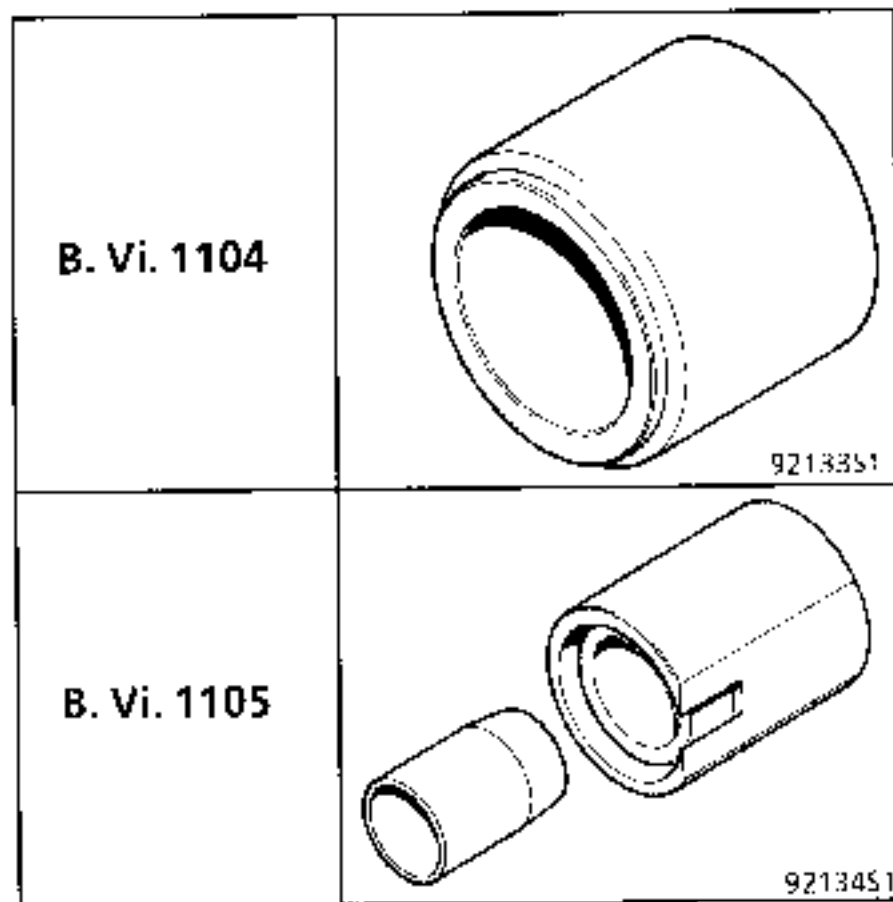

Each of the seals should be lubricated before fitting.

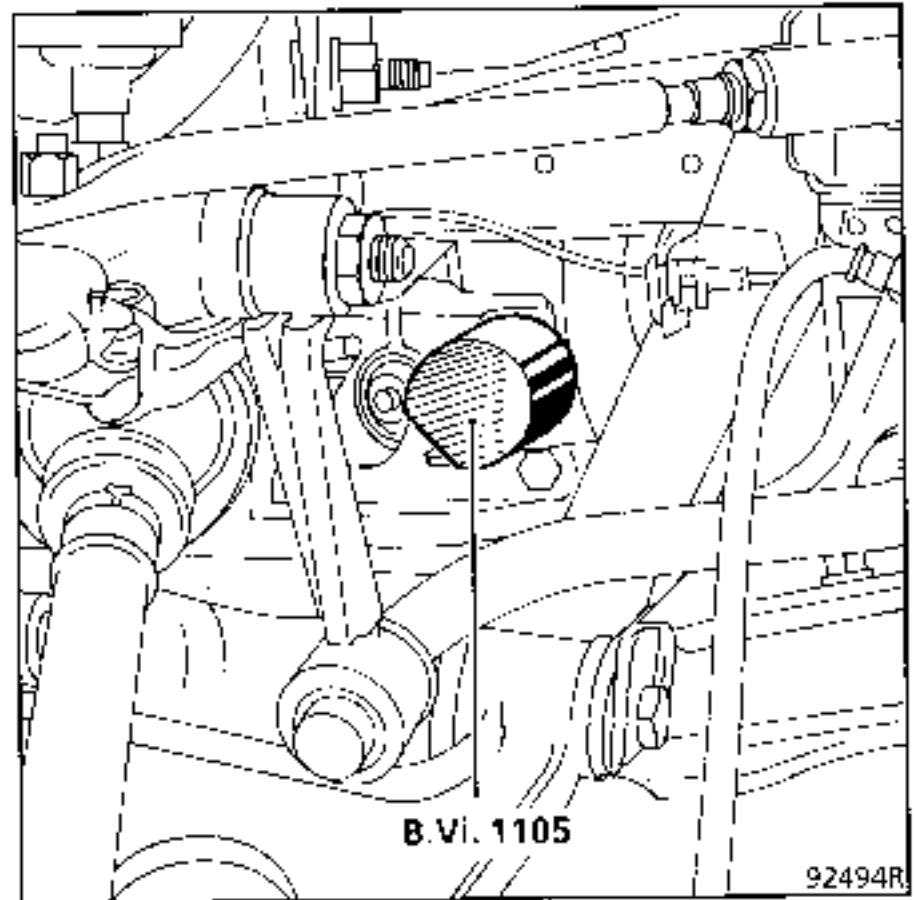

Refit the driveshaft O ring using the protective nose from tool **B.Vi. 1105**.

Coat the splines of the seal at the gearbox end with **MOLYKOTE BR2**.

Position the driveshaft in relation to the sunwheel and engage it. Check its position using the angled pin from tool **B.Vi. 31-01**.

Fit two new roll pins using tool **B.Vi. 31-01**. Seal the roll pin holes using **RHODORSEAL 5661**.

An inlet chamfer on the sunwheels makes fitting the new roll pins easier.

Refit the various components of the front axle assembly.

Fill the final drive section with the recommended oil.

1) Replacing a left or right hand seal

SPECIAL TOOLING REQUIRED		
B.Vi. 1255	Tool for removing sunwheel output flanges	
B.Vi. 1322	Tool for fitting differential output seal	

Left hand side

REMOVAL

Remove the grease from the flange.

Using a screwdriver, remove plug (A).

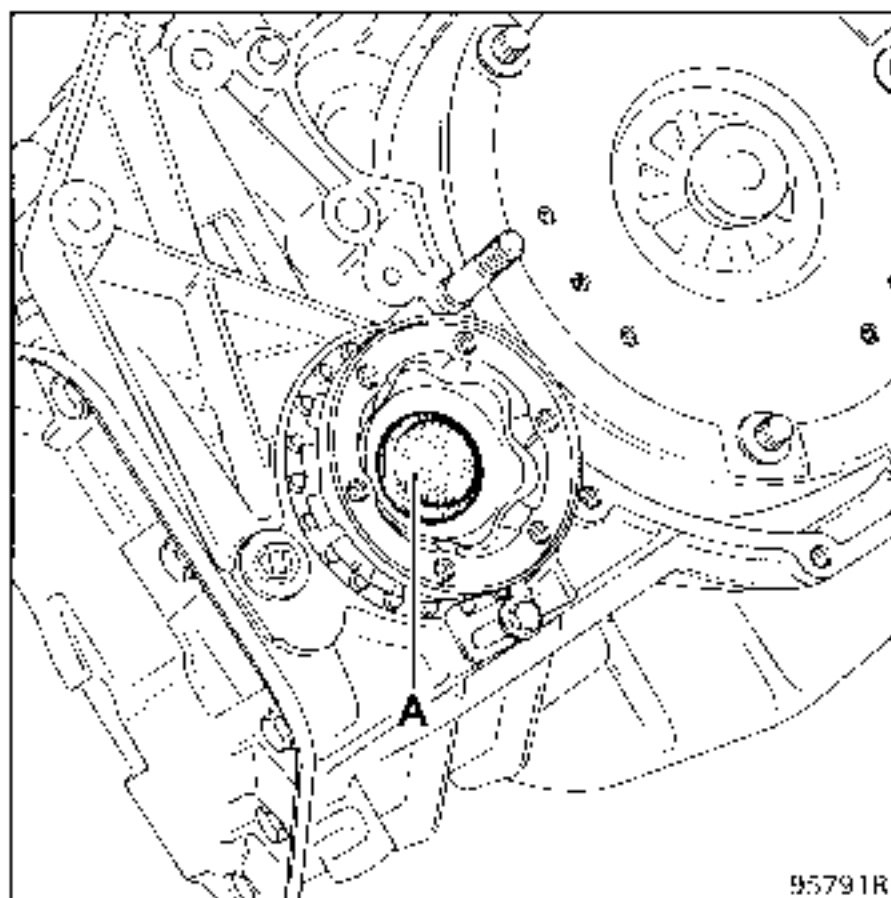

Position tool B.Vi. 1255 on the flange and compress it until the clip (B) is released.

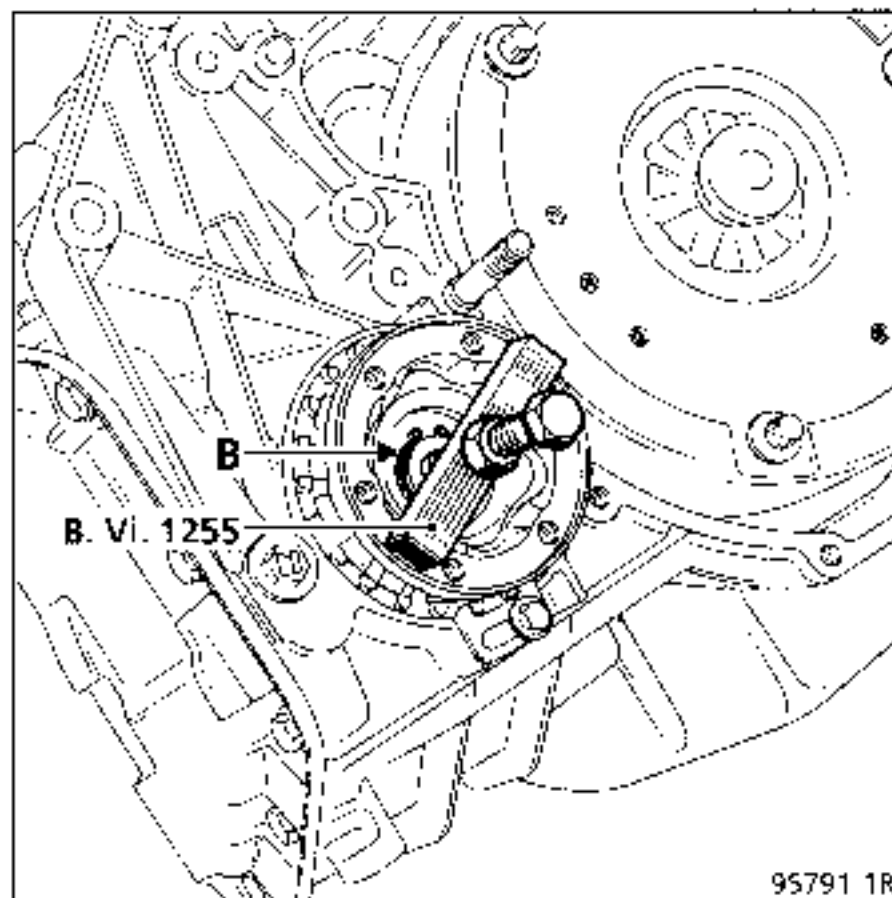

Remove the clip (B).

Decompress tool B.Vi. 125 and release the flange from the sunwheel.

Using a screwdriver, remove the seal, taking care not to damage the housing.

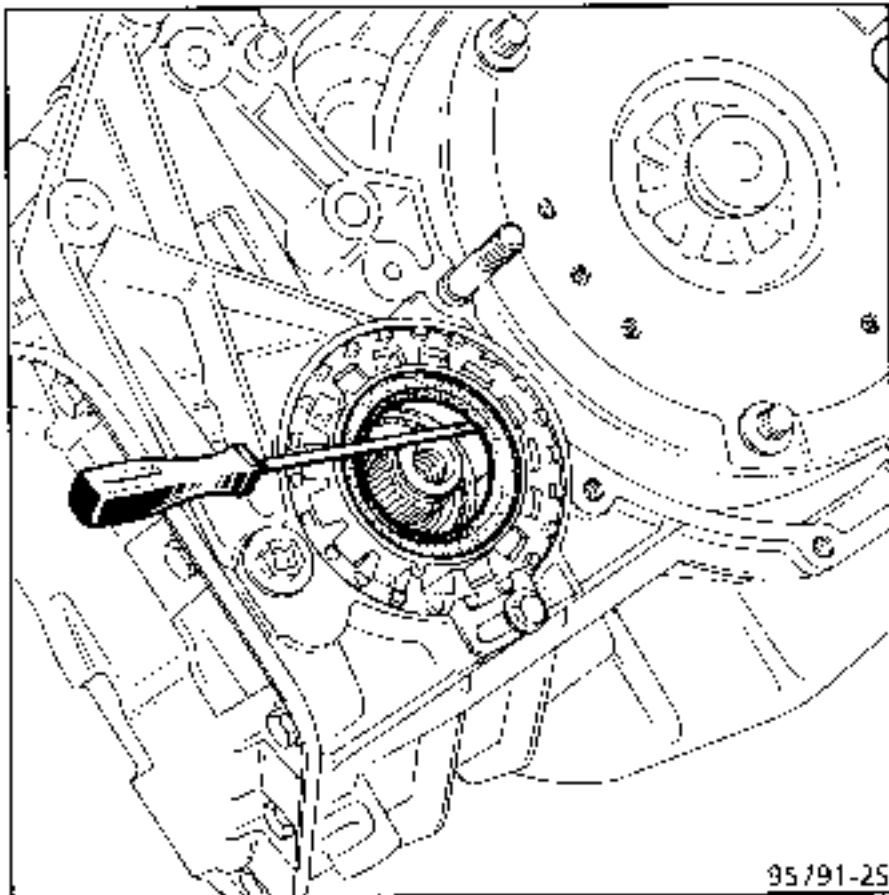

REFITTING

The lip seal (lubricated) is fitted with tool B.Vi. 1322 (this ensures the seal is correctly located).

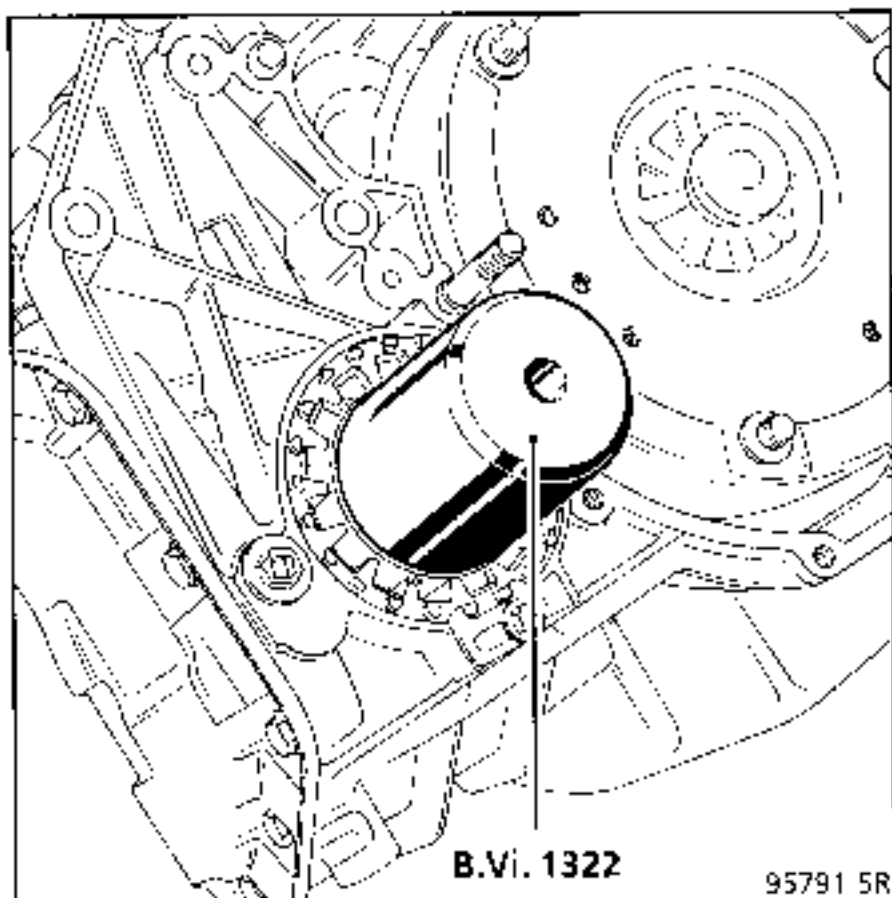

Refitting is the reverse of removal:

- the flange with its spring and the cup,
- the clip,
- the plug (new) using a tube of diameter 40 mm.

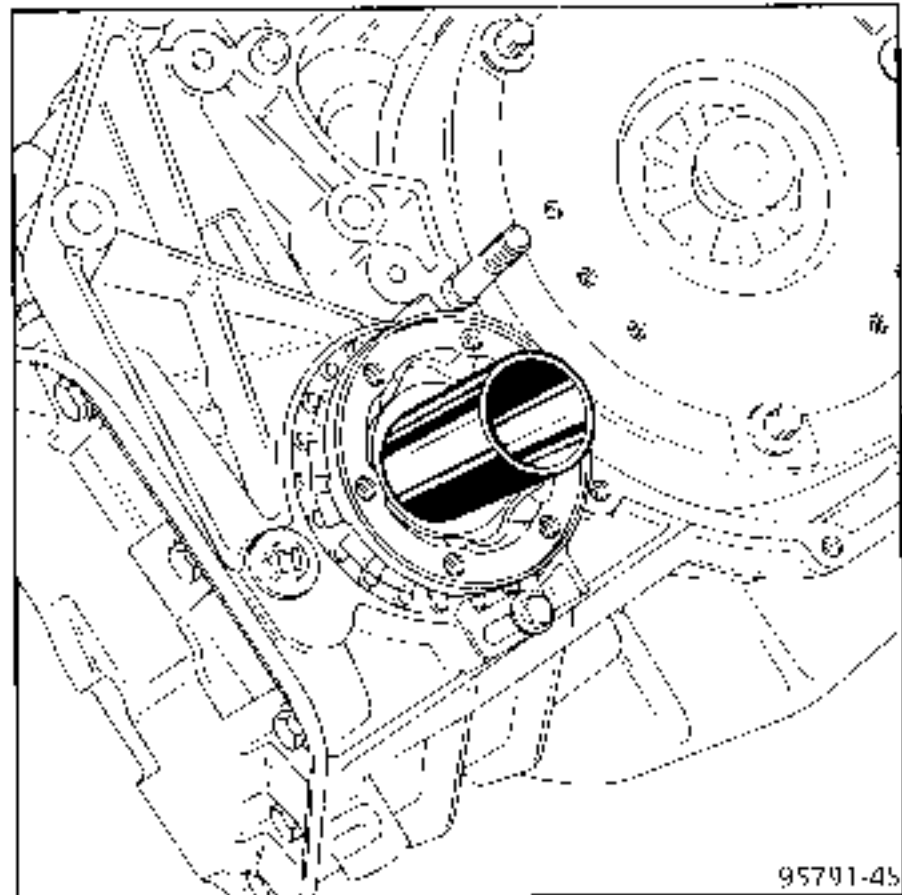

Top up the automatic transmission oil level (final drive section).

SPECIAL TOOLING REQUIRED

B.Vi. 1322 Tool for fitting differential output seal

Right hand side

REMOVAL

Using a screwdriver, remove the protective shield (A).

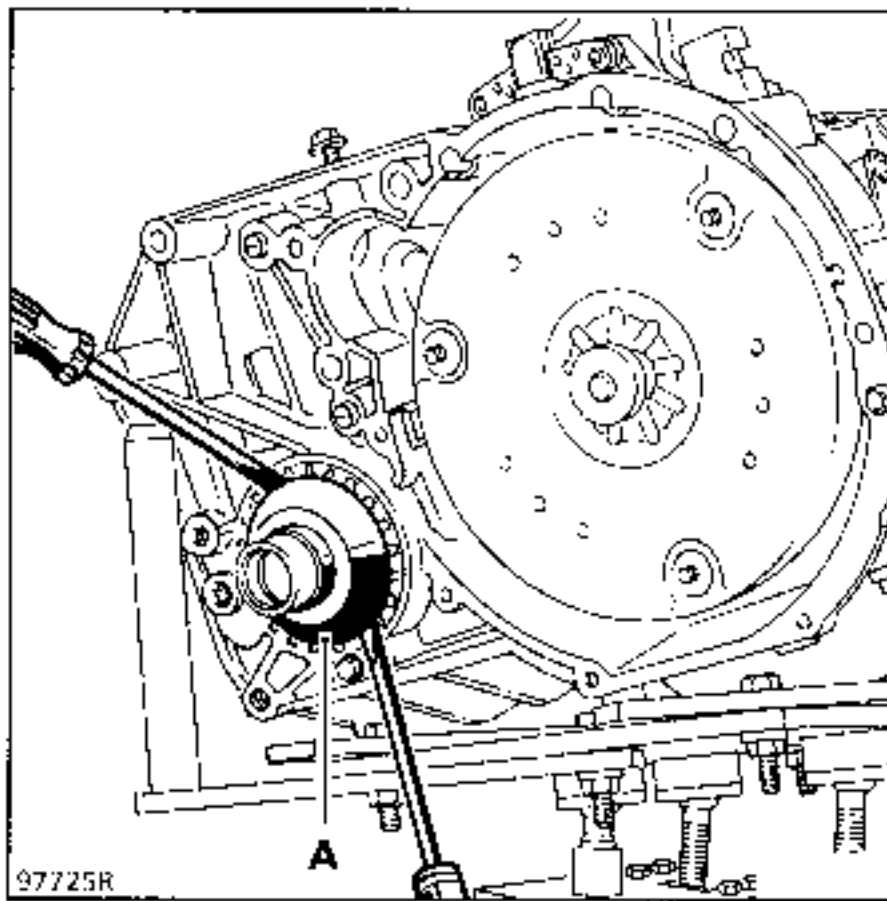

The shield is press fitted.

Using a screwdriver, remove the seal, taking care not to damage the differential bolt or the transmission output shaft.

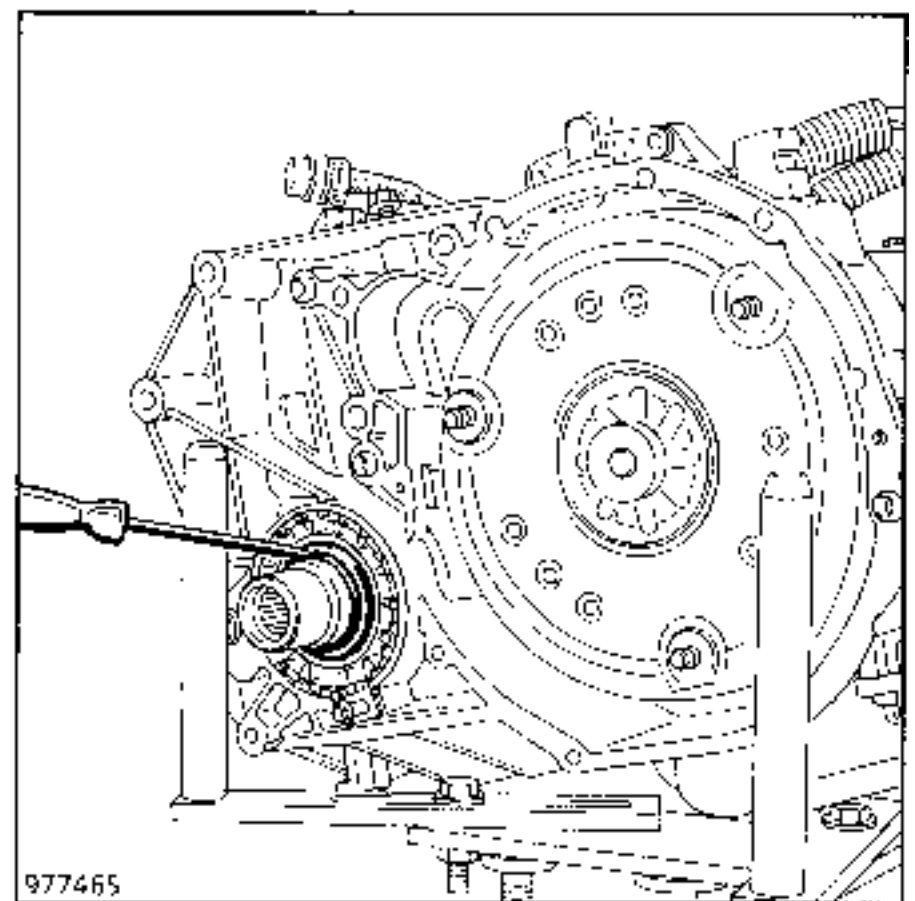

2) Replacing an O ring

The principle is the same for both sides, **but only one side should be removed at a time.**

The operation to replace the O ring is the most delicate, as the operating affects the differential bearings adjustment. To avoid unnecessary removals, try to locate the leak by cleaning the component then carrying out a road test.

SPECIAL TOOLING REQUIRED

B.Vi. 1323	Tool for fitting differential output seal
------------	---

- a) Drain the final drive and remove the flange.
- b) Mark the position of the nut (F) in relation to the housing by making a mark on one tooth and opposite on the housing.
- c) Remove bolt (D) and the locking bracket (E) for the nut using tool B.Vi. 1323, remove the nut, counting the number of turns used.

- d) Replace the O ring on the nut, after cleaning the seal bearing face and lubricating the new seal with final drive oil.
- e) Refit the nut, using the same number of turns counted on removal. Align the reference marks made on the nut and the housing. Refit bolt (D) and the locking plate (E).
- f) Refit the flange after replacing the lip seal if necessary.
- g) Fill the final drive with oil.

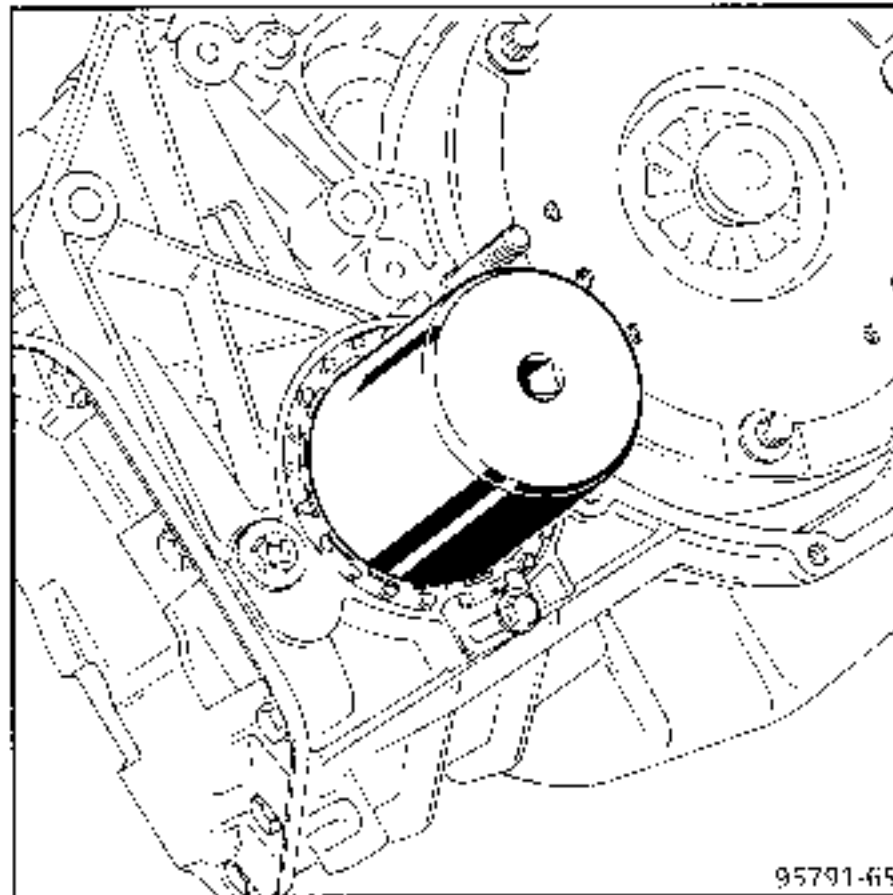
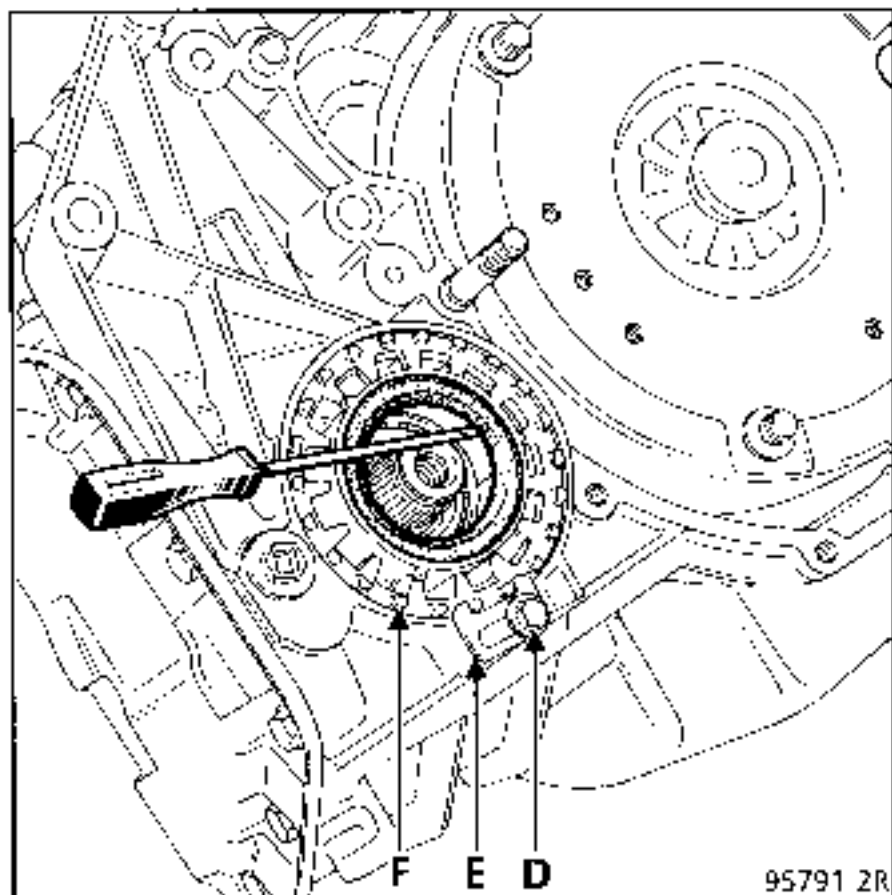

POTENTIOMETER FAULT

The kickdown switch is integral in the load potentiometer.

The computer provides load potentiometer fault information.

A fault with the load potentiometer is indicated by fixed gear change thresholds, irrespective of the position of the accelerator pedal.

1 ↗ 2 ↘ 1		2 ↗ 3 ↘ 2	
38	25	65	45

SPECIAL TOOLING REQUIRED

B.Vi. 958 Test kit

INSTRUCTION

Vehicle stationary, ignition off.

Check the accelerator cable is correctly adjusted.

Disconnect the 3 track connector (10) for the wiring connecting the computer to the potentiometer.

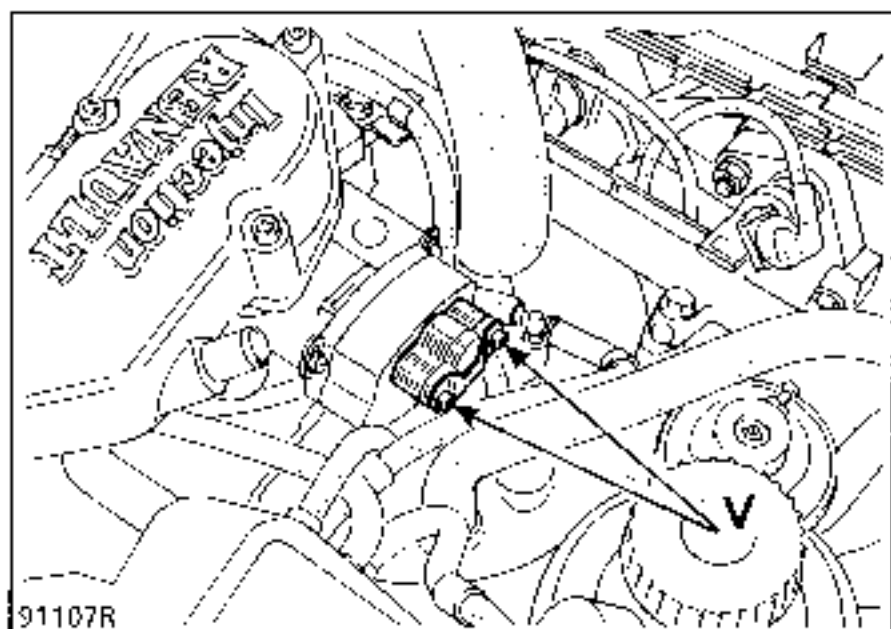

Connect connector (10) for the potentiometer to that for tool B.Vi. 958 (16).

Supply tool B.Vi. 978 from the battery.

Switch (12) on (Y).

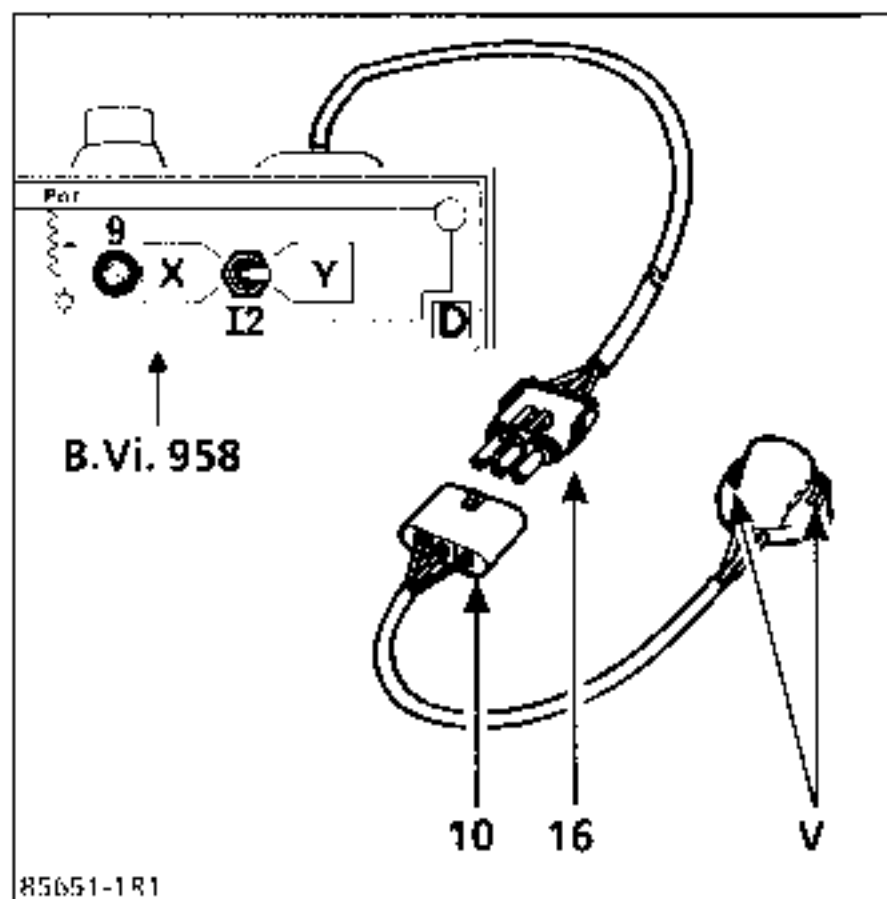
**CHECKING**

Depress accelerator pedal fully	WARNING LIGHT 9
CORRECT	
INCORRECT or badly adjusted	

ADJUSTMENT

Slightly slacken the two potentiometer mounting bolts (V).

Keep the throttle held open by the accelerator pedal and turn the potentiometer slowly to illuminate the warning light (9) then retighten the two bolts (V).

If the warning light (9) cannot be illuminated by this adjustment, check its wiring and if the potentiometer is faulty, replace it.

The potentiometer must be adjusted whenever it is replaced or removed.

NOTE : the potentiometer must be fitted to the throttle body when the engine is running at **idle speed**. In any other position there is a risk of damaging the injection full load switch.

Connect the XR25 to the vehicle's diagnostic socket.

Turn the ignition on but do not start the engine.

Enter the code for the transmission

"A" : D 0 4

The display shows the number of the computer.

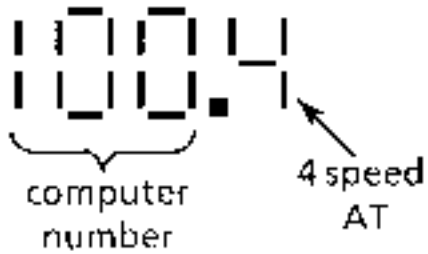
Example : 

Enter:

0 2

The display shows the value in % of the potentiometer adjustment.

Example : 

ADJUSTMENT

● Engine

Slacken the potentiometer mounting bolts (V).

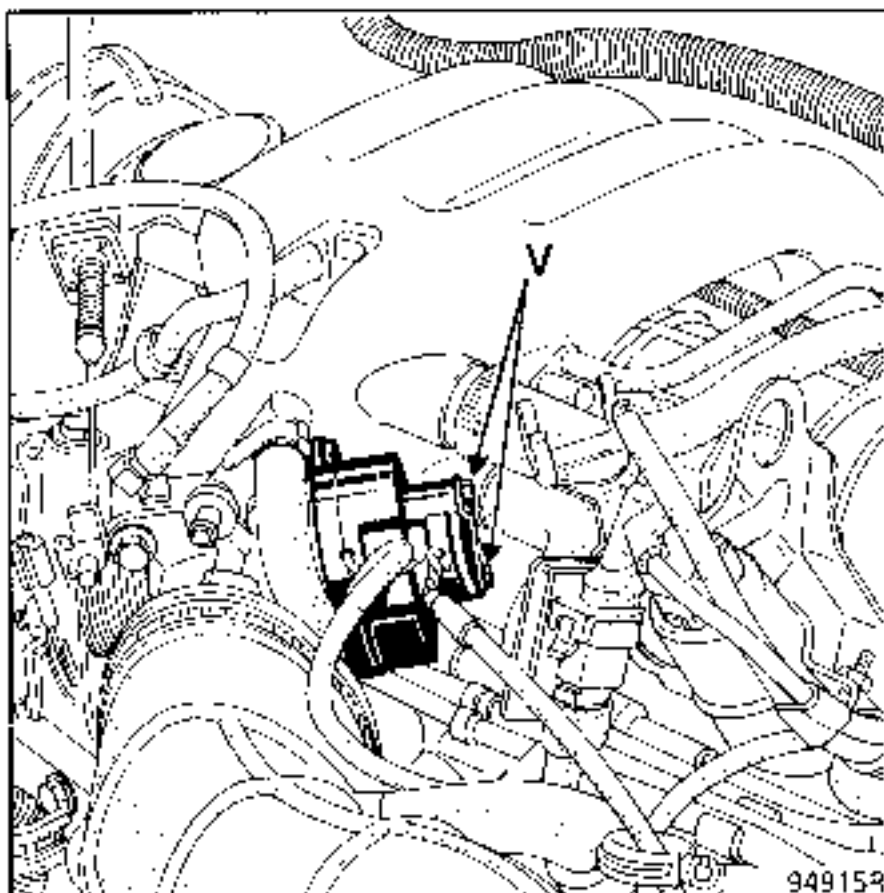

Accelerator pedal not depressed, rotate the potentiometer body until the display shows a value between 89.7 and 92.1.

Tighten the mounting bolts (V) (if adjustment is impossible, check the drive).

VERY IMPORTANT

NOW ERASE THE MEMORY AND PROGRAMME THE "FULL LOAD" VALUE.

Adjustment values:

Vehicle type	AT type	Potentiometer type	Adjustment values (check using XR25)	
			No load	Full load
X48 C/K X48 3 (BOSCH injector)	AR4	BENDIX single track potentiometer	89.7 % to 92.1 % (# 02) (no correspondence with injection)*	Value < 6 % for # 12
X48 3 (BENDIX injector) X48 2/E	AR4 AD4	BENDIX single track potentiometer	89.7 % to 92.1 % (# 02) (no correspondence with injection)*	- Kickdown switch on accelerator cable (value 0 for # 22) - Value < 6 % en # 12

* Note that the automatic transmission computer only declares the potentiometer faulty if the no load value is less than 89 % and greater than 98 % for # 02.

● F2N engine

THE LOAD POTENTIOMETER IS SPECIFIC TO THIS ENGINE. IT HAS A LONGER TRACK. IT IS NOT INTERCHANGEABLE WITH ANY OTHER TYPE OF POTENTIOMETER.

Remove the carburettor cover.

Completely slacken the idle screw (A) until the butterfly shuts completely.

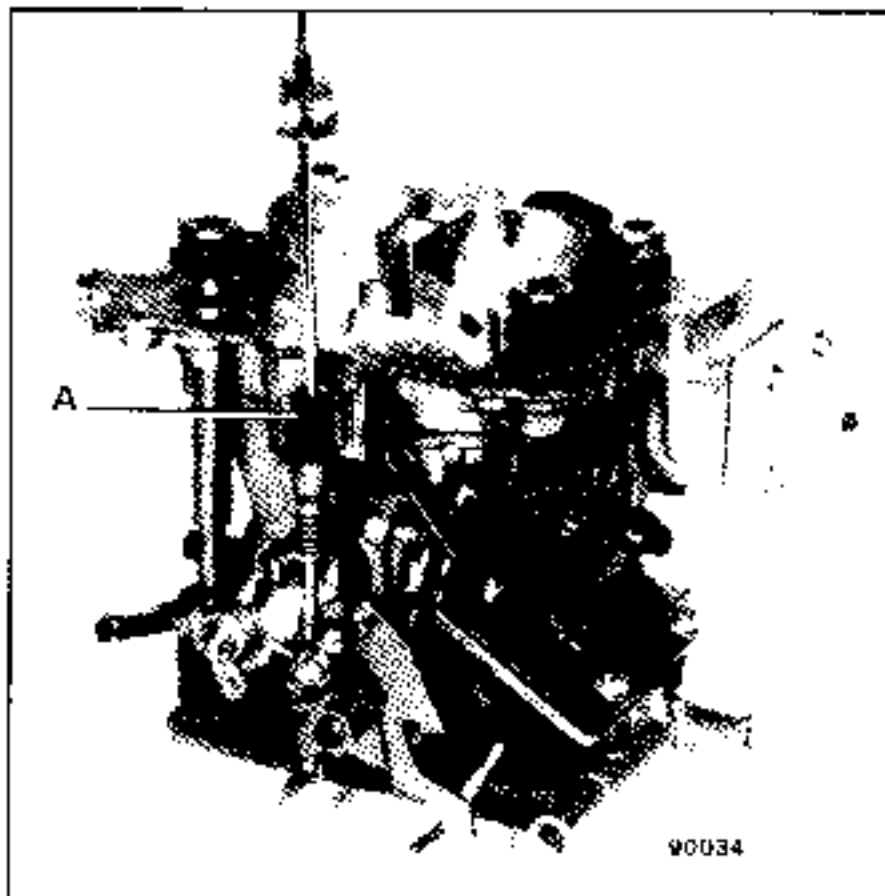

Slacken the potentiometer mounting bolts (V).

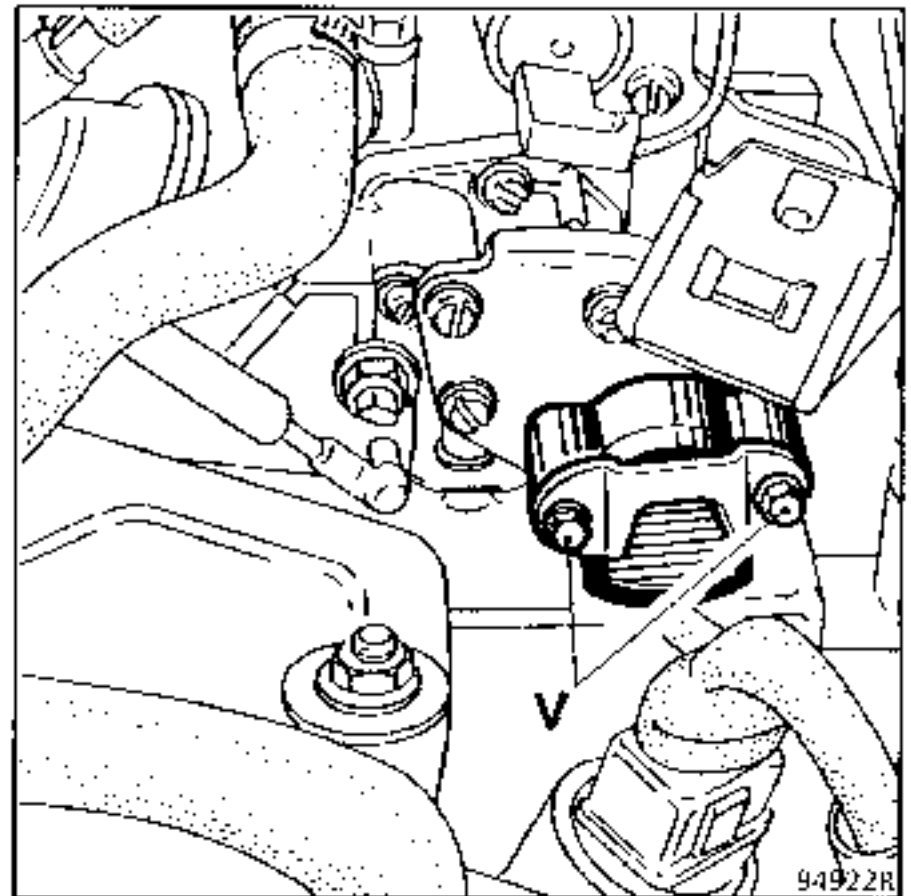

Rotate the potentiometer body until the display shows a value between 89.7 and 92.1.

Retighten the mounting bolts (V) (if adjustment is impossible, check the drive).

Refit the carburettor cover.

Adjust the idle speed to 800 ± 50 rpm, lever in Neutral.

NOW ERASE THE MEMORY AND PROGRAMME THE "FULL LOAD" VALUE.

REPLACEMENT

If any oil leaks from the transmission rear plugs (primary and secondary line plugs), they may be replaced without removing the transmission.

Use a screwdriver to remove the plugs.

When refitting, grease the plug (follow the method for replacing a lip seal) and use tool **B.Vi. 1106**.

Push the seal on until it is up against the casing.

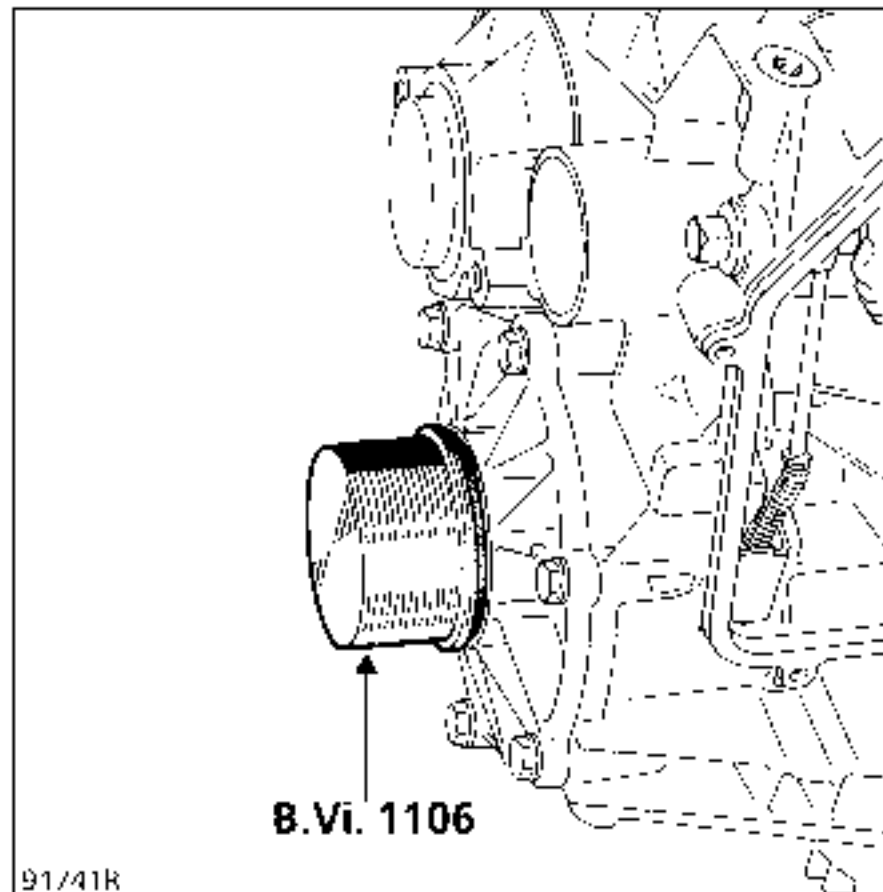

SPECIAL TOOLING REQUIRED

B.Vi. 1215-01 Oil pressure gauge

CHECKING

Measuring conditions:

The normal operating temperature is **80 °C**.

Ensure that the accelerator cable is correctly adjusted.

Connect the oil pressure gauge to the end piece at (A).

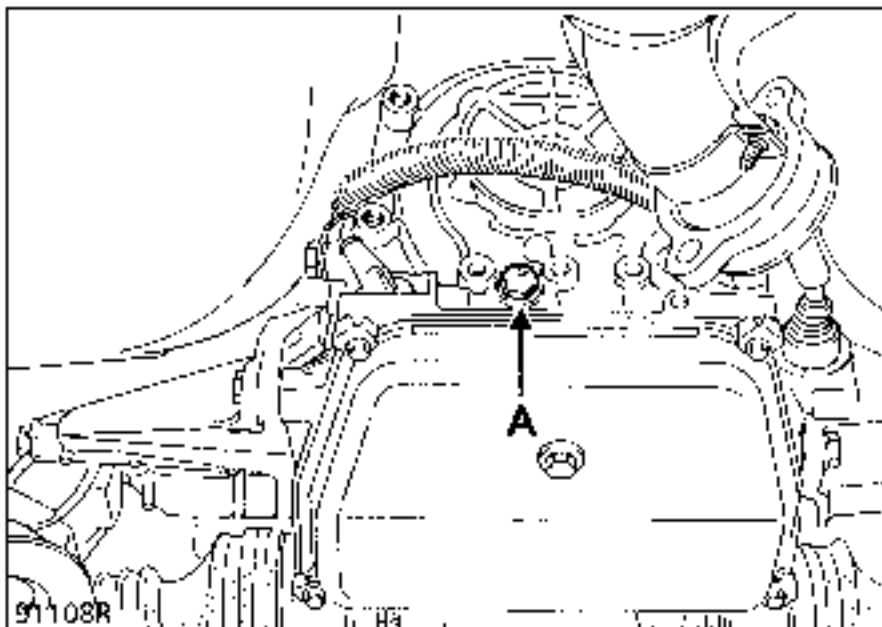

Measure :

Put the selector lever in **2nd gear hold**.

Accelerate fully and brake at the same time to stabilise the speed at **50 mph (80 km/h)**.

The pressure should be : **4.7 ± 0.1 bar**.

ADJUSTMENT

Remove catch (1) and turn the capsule over. The pressure is increased by tightening up the capsule and vice versa.

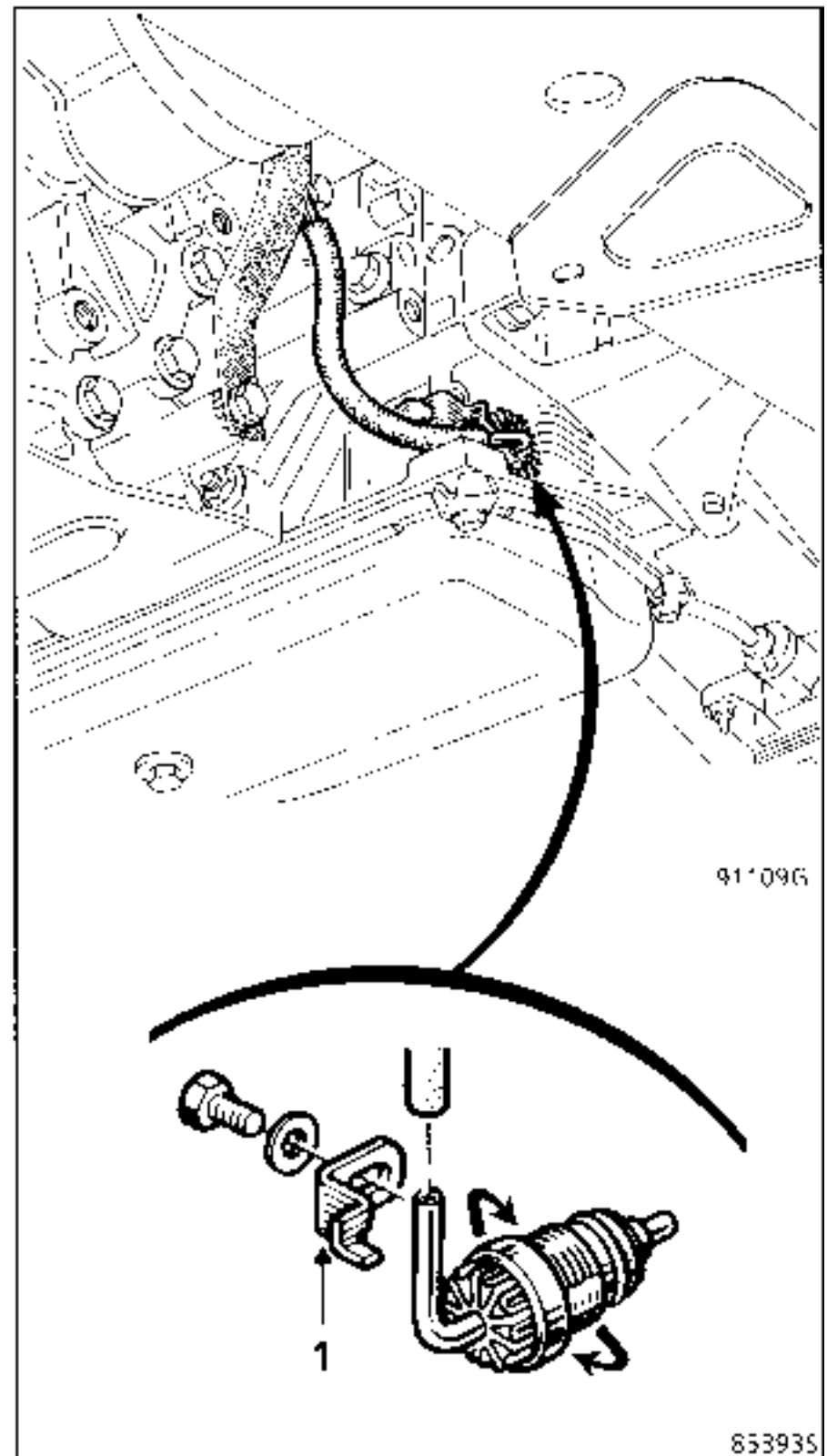

NOTE : 2 notches = approximately 0.08 bar.

A tool may be made to facilitate this operation.

A : washer, diameter 8/30 mm, thickness 1.5 mm.
B : round rod, diameter 6 mm.

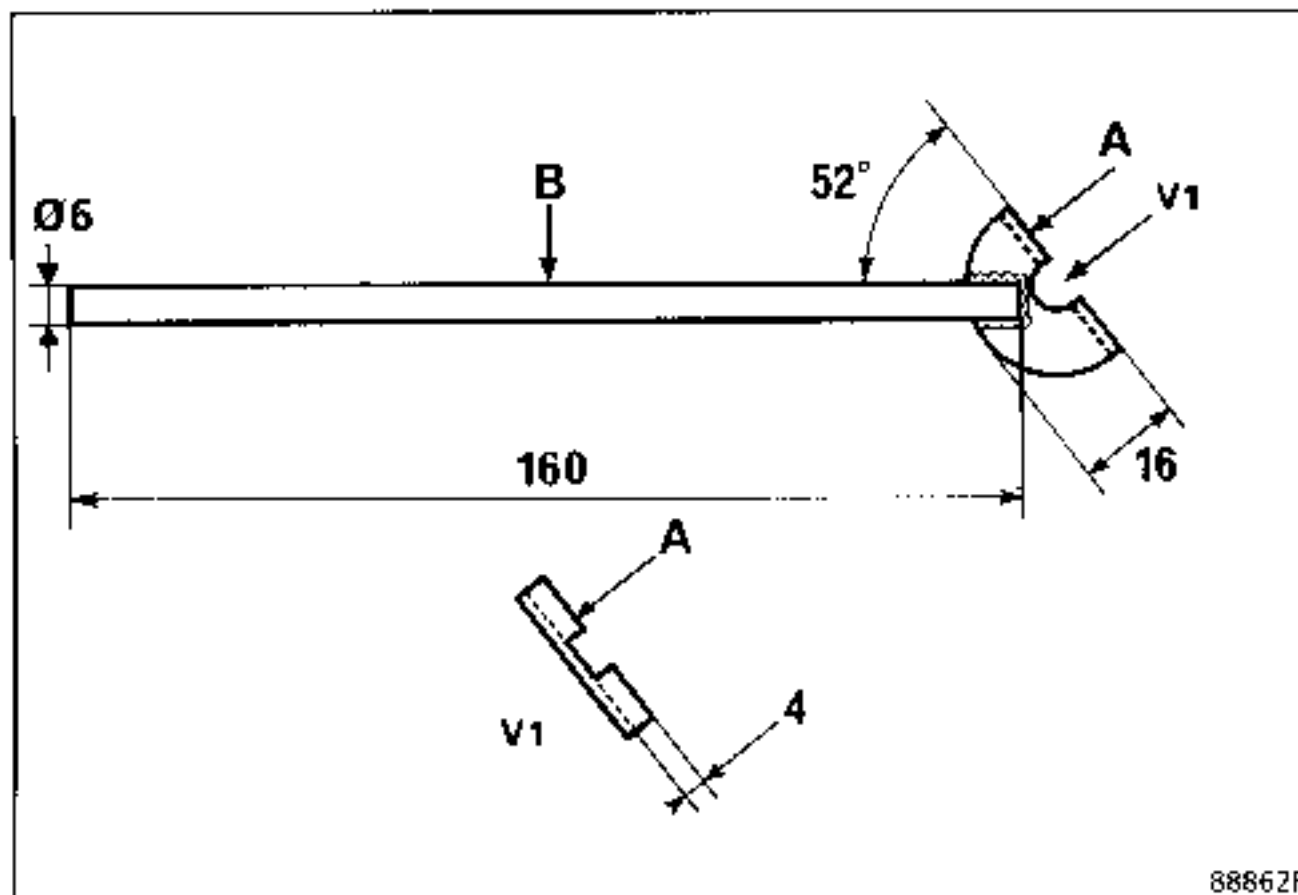



879705

The electronic fault warning light detects faults of an electrical and electronic nature in the automatic transmission and injection systems.

CONSEQUENCE FOR FAULT FINDING USING THE B.Vi. 958

The kickdown switch is adjusted by adjusting the load potentiometer. The warning light (6) of tool B.Vi. 958 is no longer used to show the correct operation of the kickdown switch, but to show the correct operation of the multifunction switch, with the starter function in position "P" and "N" and the ignition on.

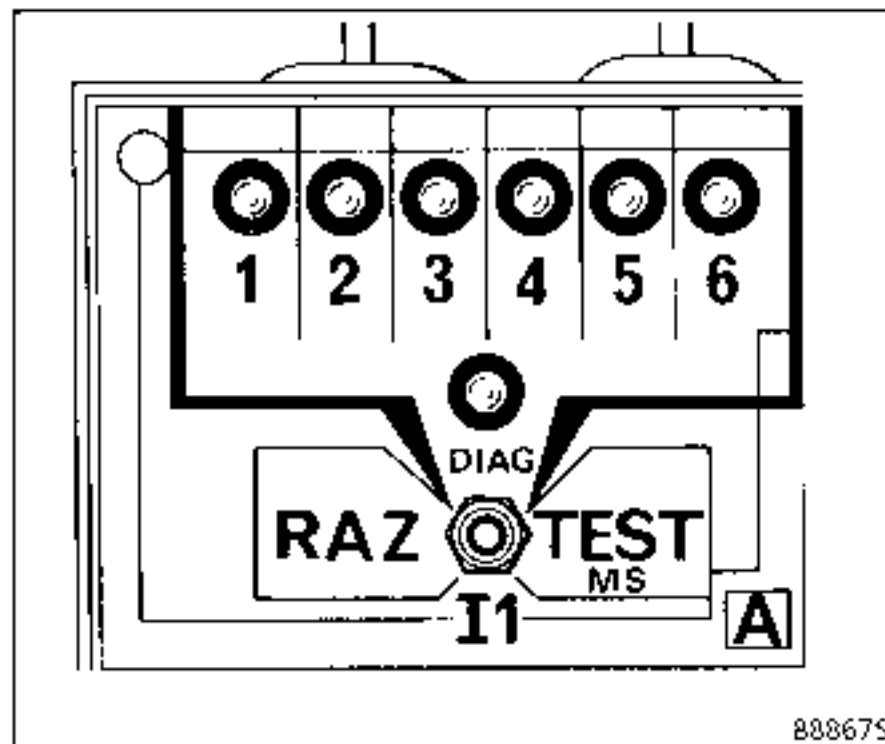

888675

MODIFICATION

The secondary shaft nut on the MJ final drive is slackened using tool B.Vi. 953, modified by grinding following a change in the helix angle of the secondary pinion.

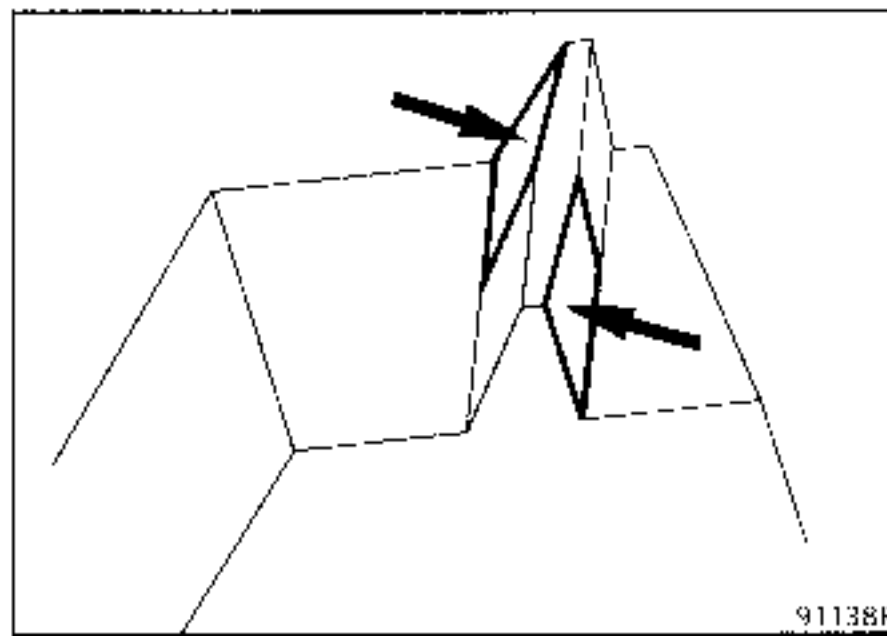

91138R

ELECTRONIC FAULT WARNING LIGHT MESSAGE



The electronic fault warning light detects faults of an electrical and electronic nature in the automatic transmission and injection systems.

Operation with no fault present

- When the ignition is turned on, vehicle stationary and engine not running, lever in **P** or **N**, warning light illuminates.
- When the starter is activated, warning light remains illuminated.
- When the key is released, ignition on, engine running, it extinguishes approximately **3 seconds** after the engine starts.

Fault present

- Vehicle stationary, engine running or when driving, warning light illuminated permanently.
- Vehicle moving, warning light illuminates and extinguishes with no action at the ignition key.
- Vehicle moving, warning light illuminates briefly.

Oil temperature < -25 °C or > + 145 °C

- Vehicle moving or stationary, warning light flashes **approximately once a second**. In this case, reduce the requirement for performance by moderating acceleration.

OIL PRESSURE

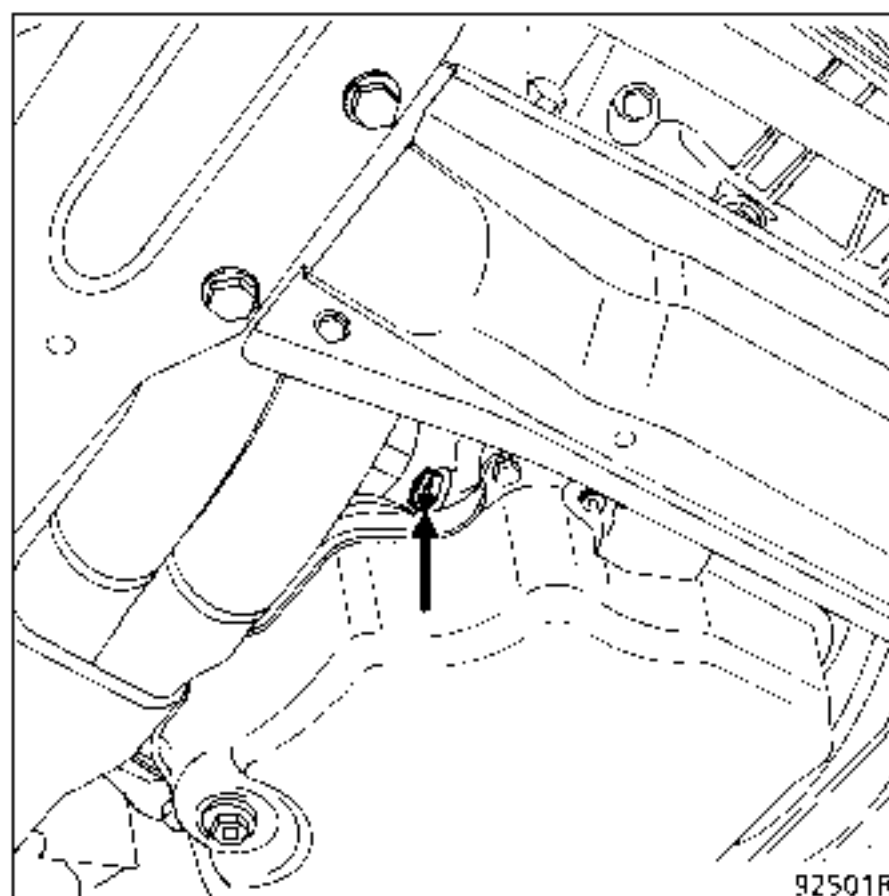

The transmission has an oil pressure take-off. Connect tool **B.Vi. 1215-01** to this point to check the transmission pressure sensor only.

The oil pressure cannot be adjusted.

Its value is determined by the computer.

SPECIAL TOOLING REQUIRED

Mot.	582	Drive plate locking tool
B.Vi.	31-01	Set of punches, diameter 5 mm
B.Vi.	465	Converter retaining bracket
T.Av.	476	Ball joint extractor

REMOVAL

The transmission does not have to be drained for this operation if it is not to be dismantled.

Place the vehicle on a lift.

Disconnect the battery.

Remove the front wheels.

Remove the driveshaft roll pins (tool B.Vi. 31-01).

Disconnect the track rod end (tool T.Av. 476).

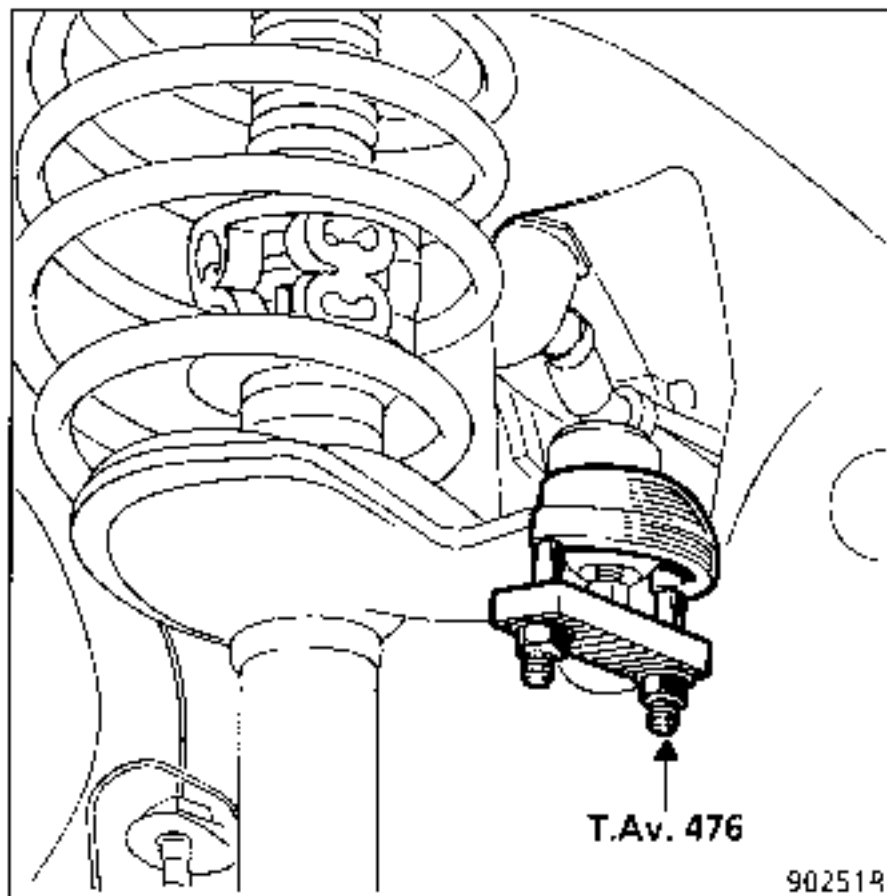

On the right and left hand sides, slacken the lower shock absorber base mounting bolts (2) and remove the upper bolts (1).

NOTE : the bolts have a splined section so a mallet must be used to remove them.

TIGHTENING TORQUES (in daN.m)



Wheel bolts	9
Shock absorber base mounting nut	20
Track rod end nut	4
Converter mounting bolt	3
Oil union nut	2
Brake caliper guide bolt	3.5
Automatic transmission mounting pad bolt	4

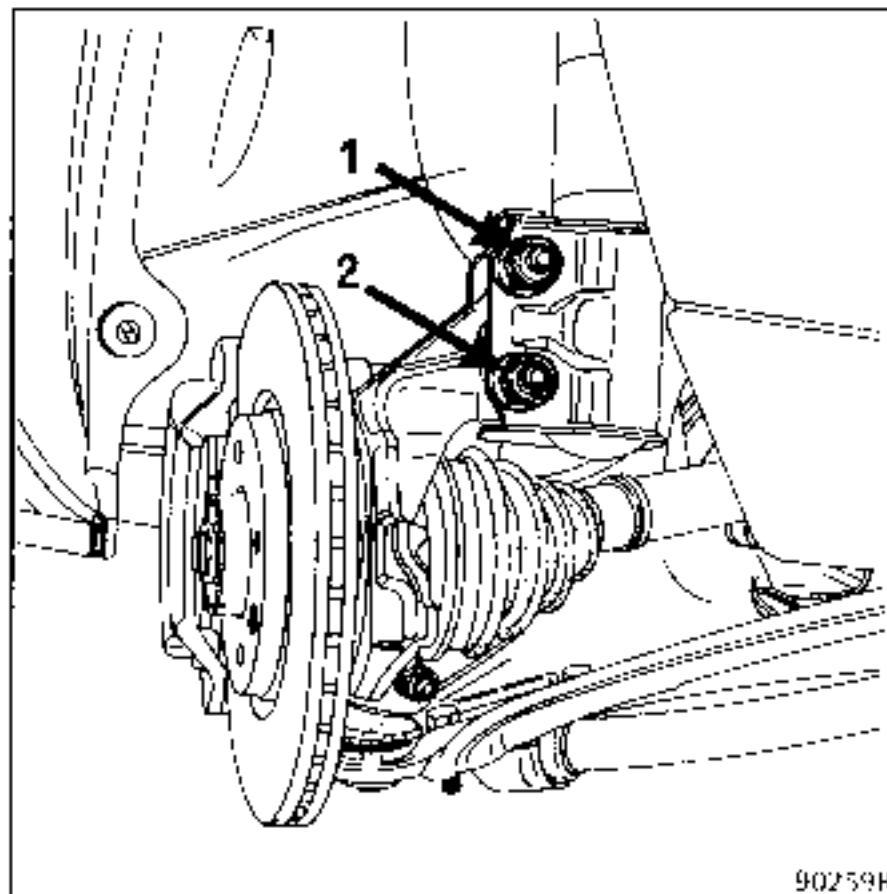

Tilt the stub axle carriers and release the driveshafts.

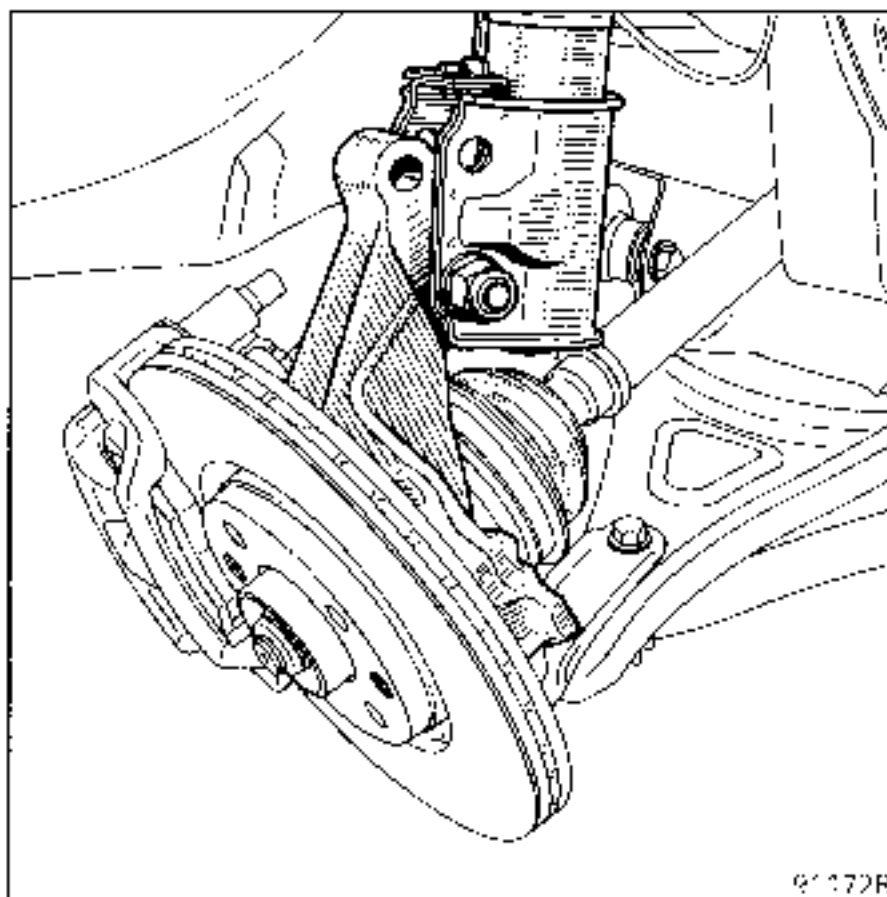

Disconnect the **A.E.I.** sensor.

Free the access to the starter motor.

Remove the starter motor.

Fit tool **Mot. 582** for locking the starter motor ring gear.

Remove the three converter mounting bolts (**V**) via the hole in the starter motor.

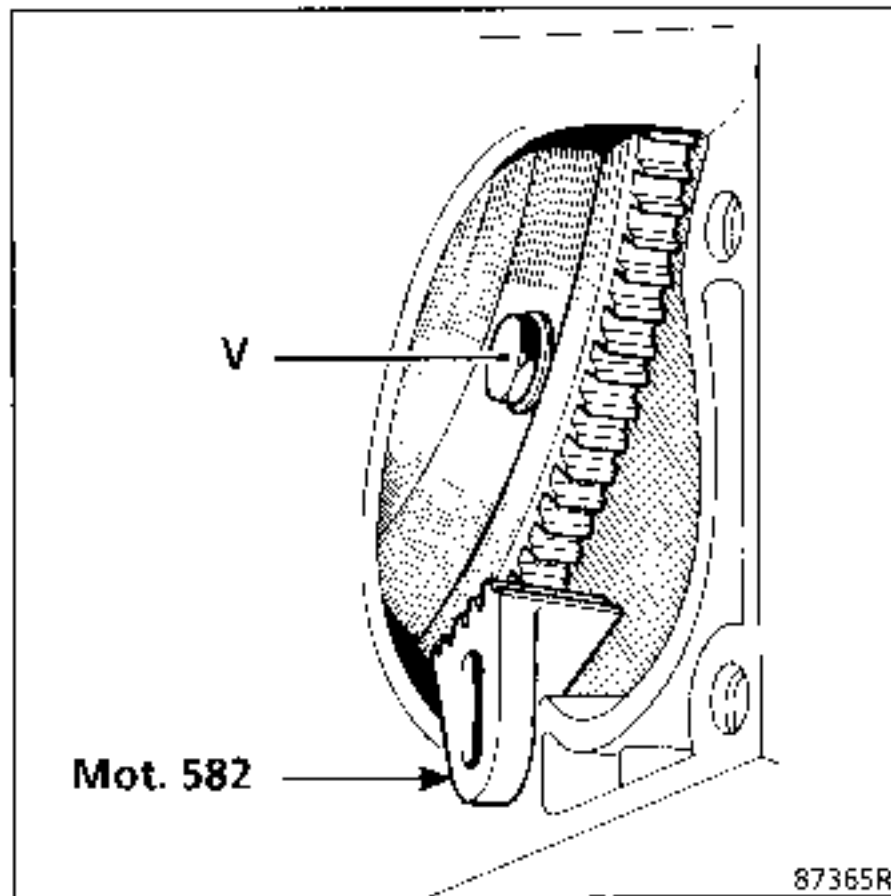

Remove the upper mounting bolts from the edge of the transmission.

Remove the primary exhaust pipe (flange on manifold - ball joint and mounting on right hand transmission mounting).

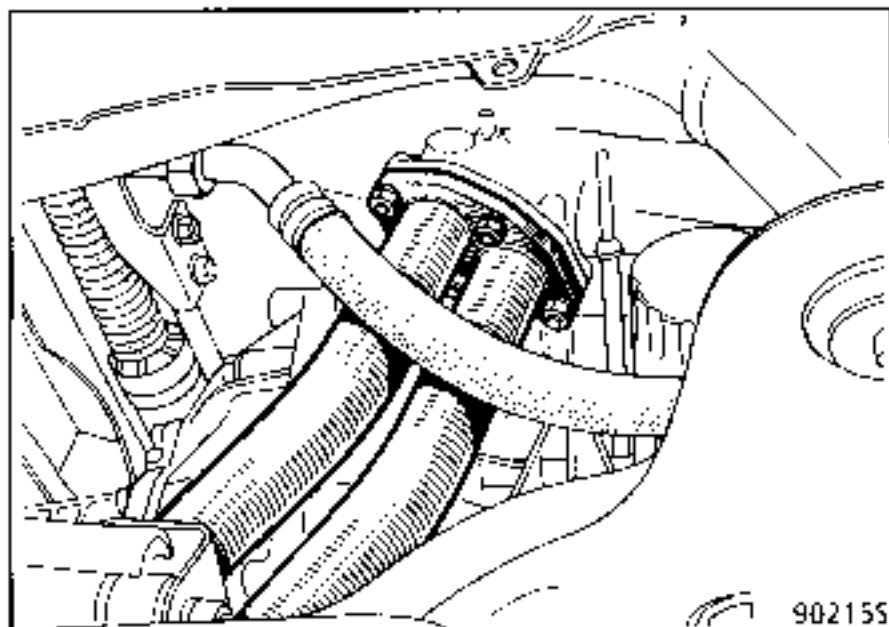

Disconnect the computer from the vehicle harness and release it, leaving it attached to the transmission.

Disconnect the capsule vacuum pipe near the starter motor flange.

Disconnect the oil cooler unions at the exchanger (**A**) and remove their mountings on the right hand side member (**B**).

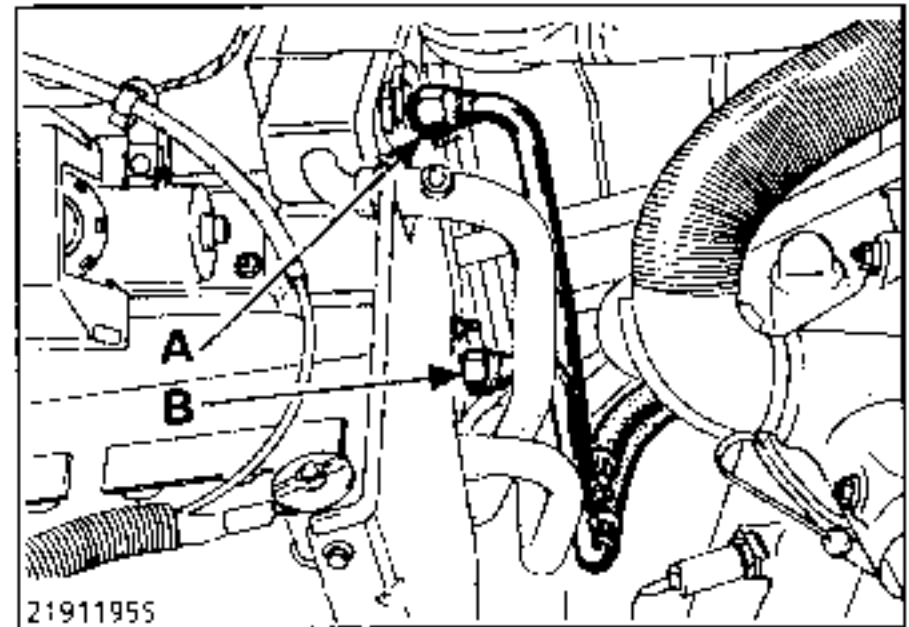

Disconnect the gear control, releasing the outer ball joint using a screwdriver.

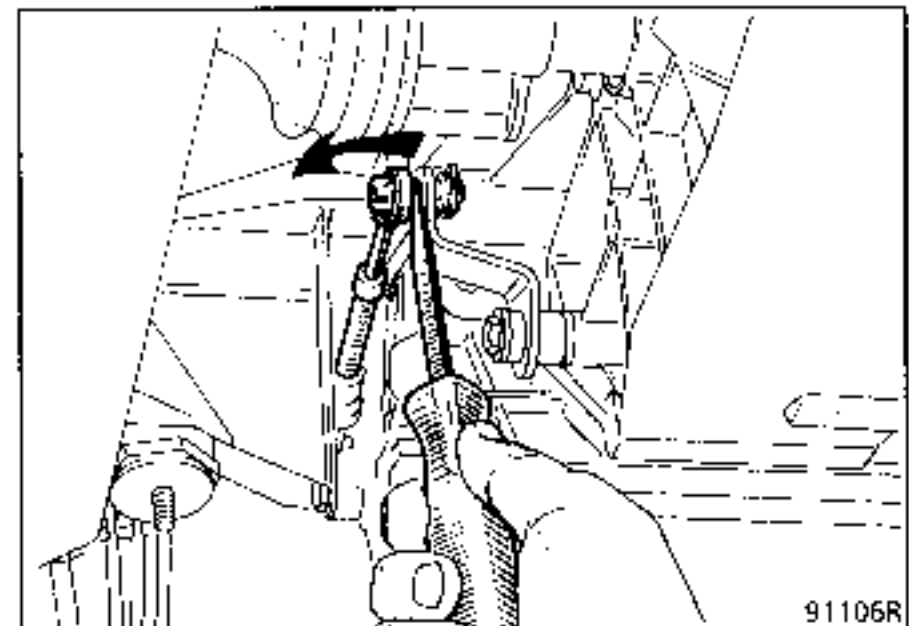

Disconnect the earth strap from the transmission.
Put a component jack into position.

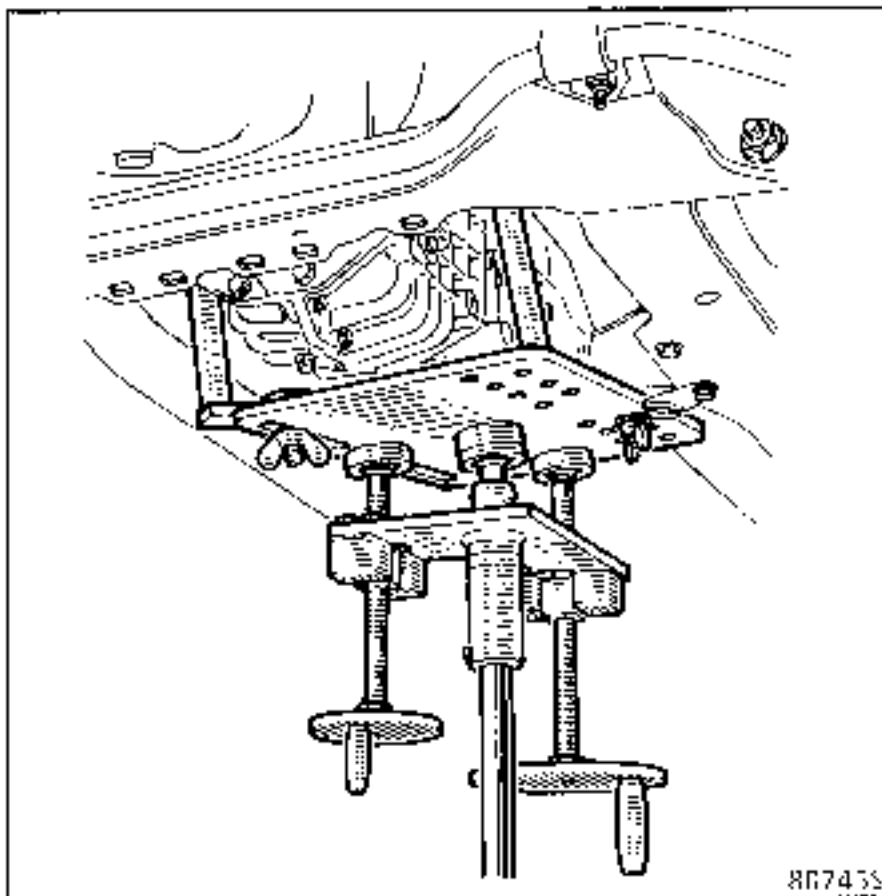

Slacken the rear mounting bolts for the engine / transmission cradle to lower it by 15 mm.

Remove the left hand mounting pad and the transmission mounting.

Slacken the three mounting bolts for the right hand mounting on the transmission.

Slacken the mounting nut for the right hand rubber mounting pad and leave the assembly in place with the control cable.

Slacken the lower engine - transmission mounting bolts.

As the automatic transmission is lowered, follow it with the computer and the oil cooler pipes.

As soon as the parts have been released, fit the retaining bracket **B.Vi. 465** to prevent the converter from coming apart.

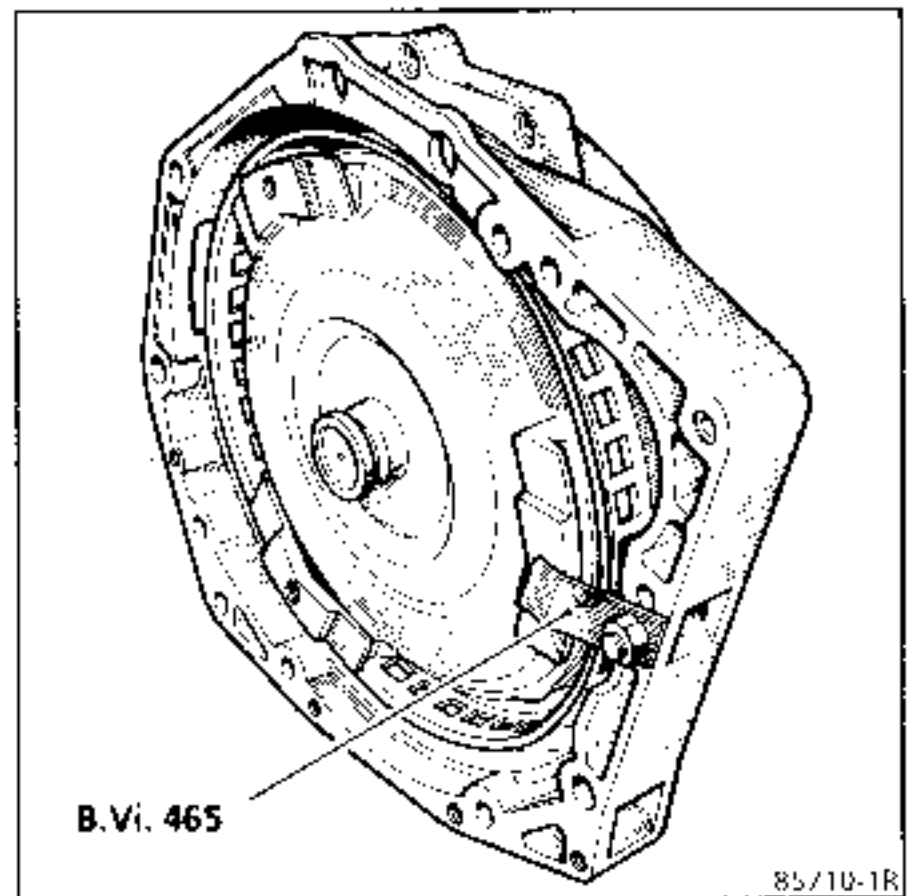

REFITTING

Before refitting the automatic transmission to the vehicle, check the centring dowels (A) and (B) are present on the engine block.

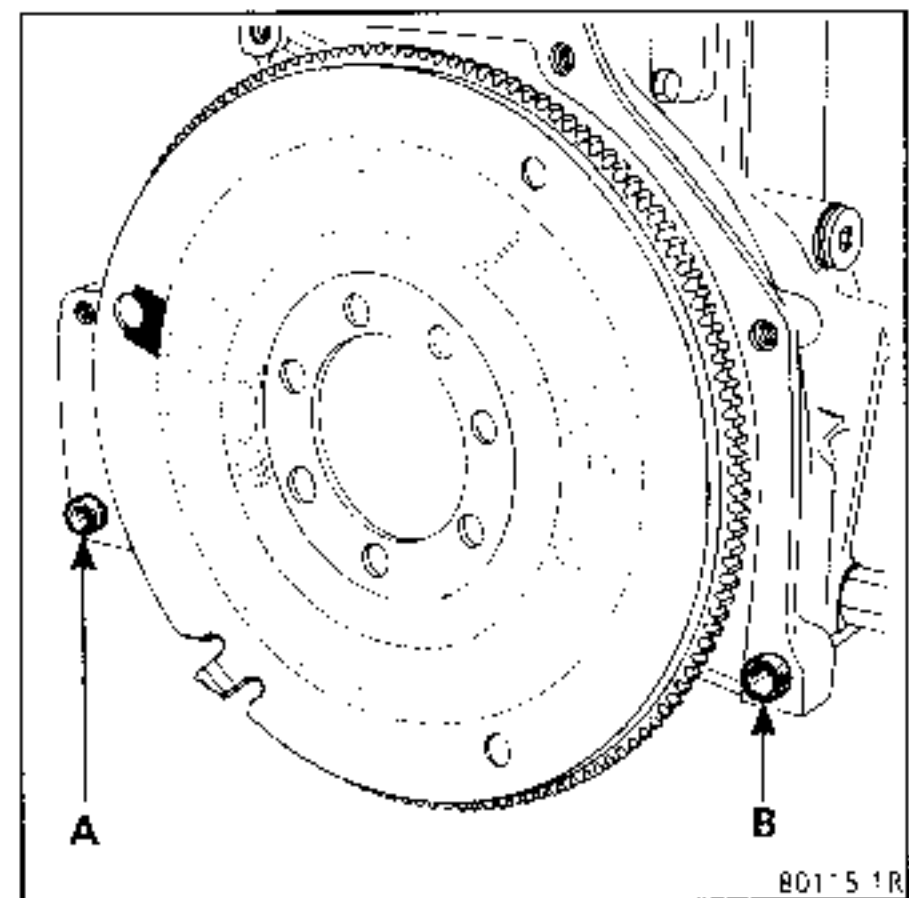

Lubricate the device centring the converter on the crankshaft and the sunwheel splines using **MOLYKOTE BR2**.

Place the converter in its initial position in relation to the drive plate.

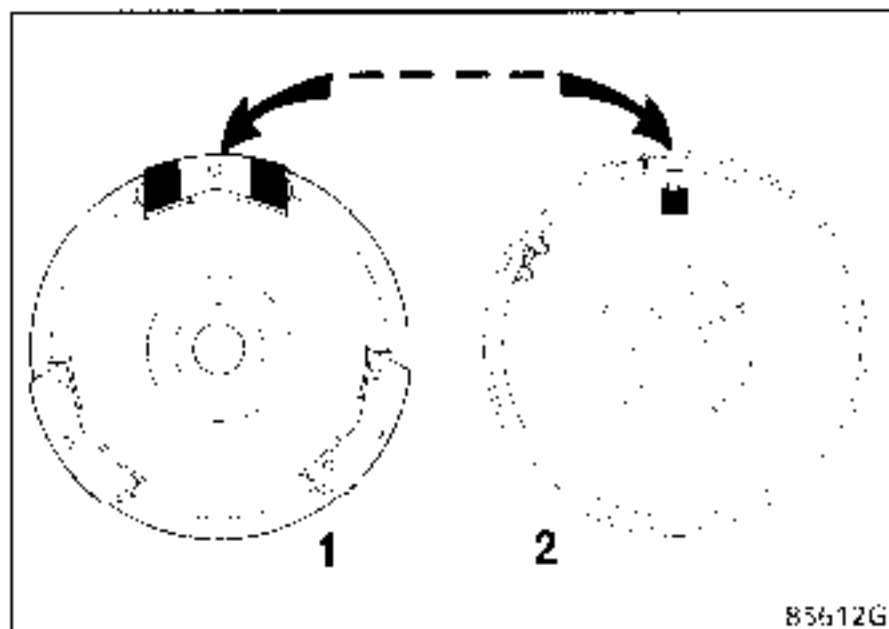

- 1 Converter
- 2 Drive plate

Assemble the engine and transmission and refit the side mountings.

Tighten the drive plate mounting bolts on the converter to a torque of 3 daN.m.

DO NOT USE THE IGNITION SENSOR TARGET TO IMMOBILISE THE DRIVE PLATE / CONVERTER ASSEMBLY.

Use tool Mot. 582.

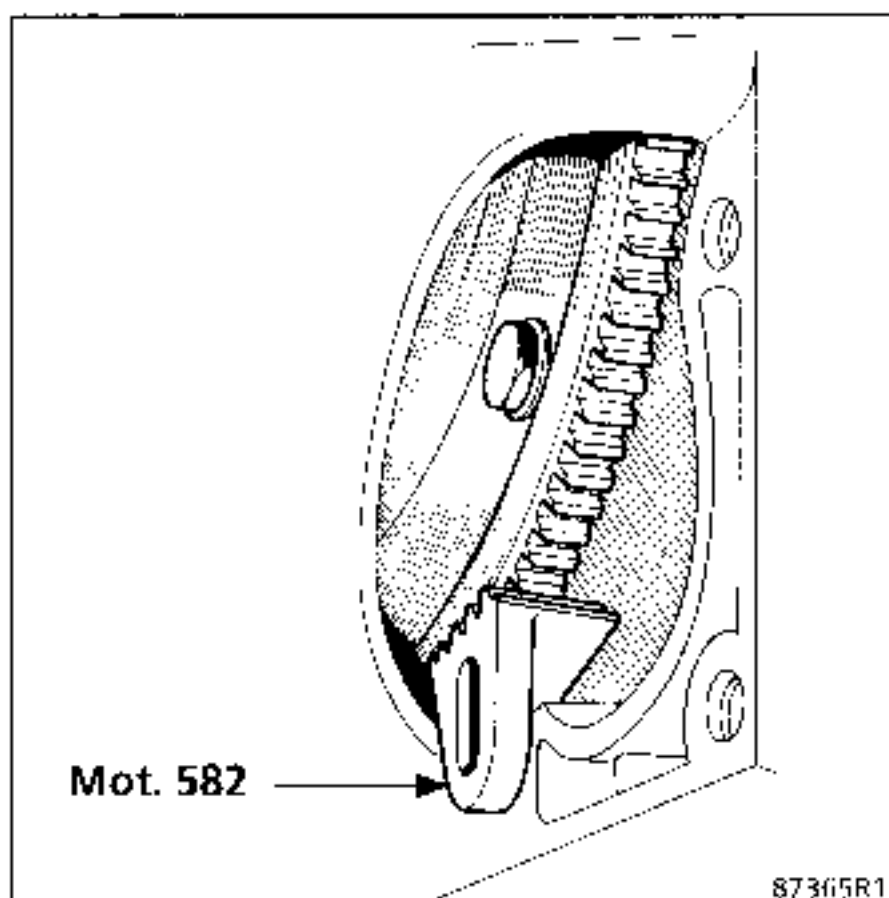

Ensure the starter motor centring pin is present.

Refit the starter motor.

Ensure the rubber washer is present which should be fitted between the end of the sunwheel and the bottom of the driveshaft yoke.

Position the driveshaft in relation to the sunwheel, tilt the stub axle carriers and engage the driveshafts into the sunwheels using the angled pin B.Vi. 31-01 to align the holes.

Fit new roll pins and seal the ends (RHODORSEAL 5661).

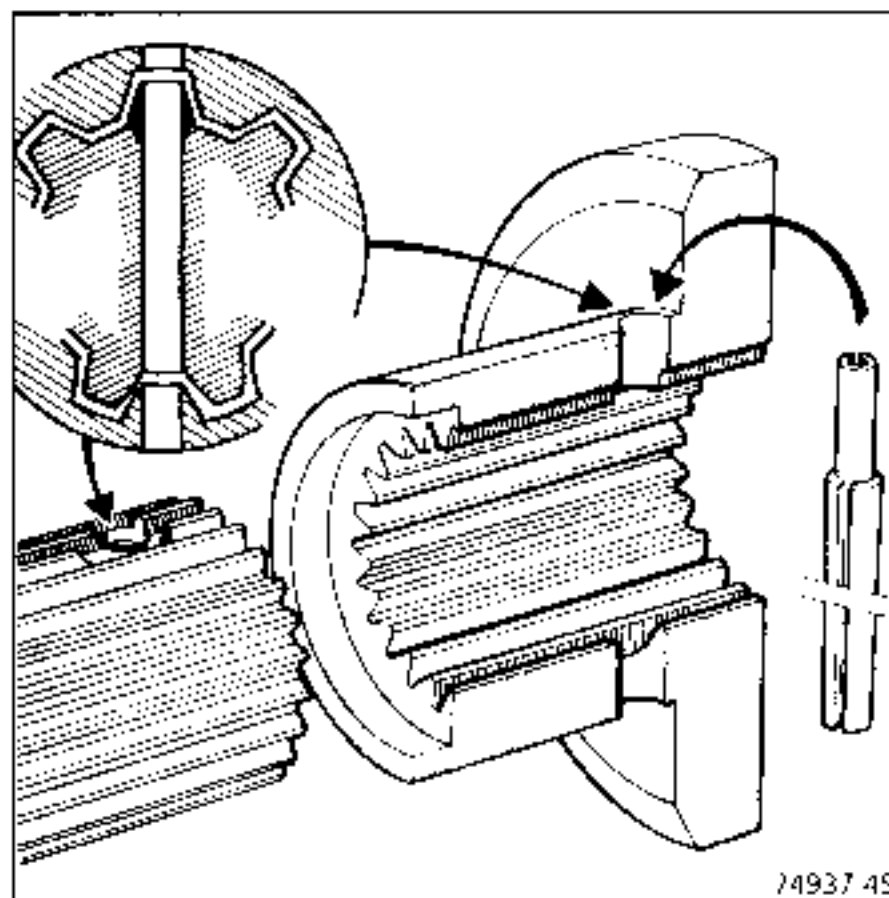

NOTE : An inlet chamfer on the sunwheels makes fitting the new roll pins easier.

Reconnect the A.E.I. sensor.

Refit:

- the shock absorber base bolts to the stub axle carriers and torque tighten them,
- the track rod end, then tighten it to the correct torque.

Reconnect the gear control. Adjustment is not necessary if the control assembly has not been removed.

Connect the speedo cable.

Fit the oil cooler pipes into position and torque tighten the unions.

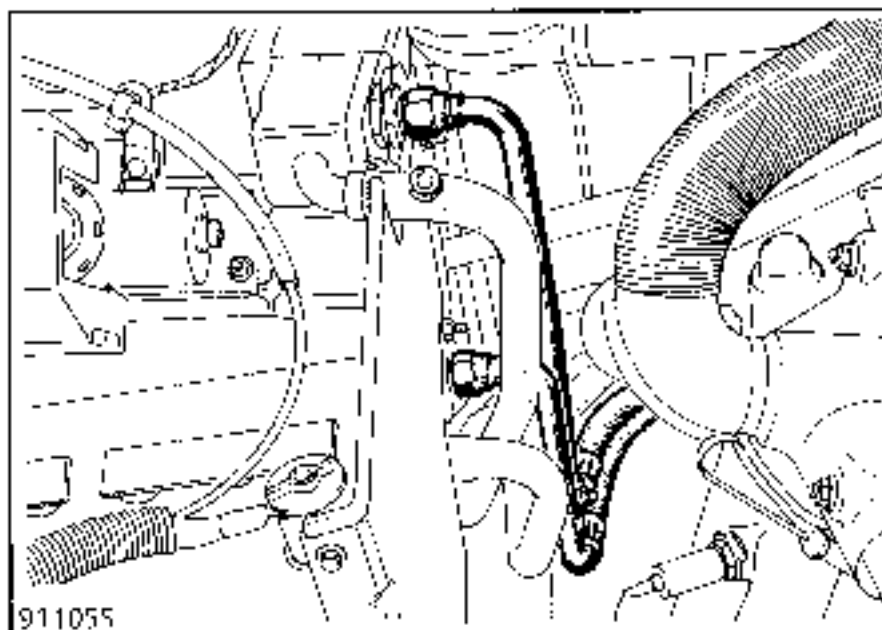

Refit:

- the exhaust flange,
- the wiring and the computer (check the wiring is correctly routed and secured),
- the earth strap.

Connect the vacuum pipe.

Fill the transmission with oil.

Check the oil level.

Test drive the vehicle.

SPECIAL TOOLING REQUIRED

Mot.	453-01	Hose clamp pliers
Mot.	582	Drive plate locking tool
B.Vi.	31-01	Set of punches, diameter 5 mm
T.Av.	476	Ball joint extractor
M.S.	583	Hose clamp pliers

TIGHTENING TORQUES (in daN.m)

Wheel bolts	9
Shock absorber base mounting nut	20
Track rod end nut	4
Converter mounting bolt	3.5
Brake caliper guide bolt	3.5
Automatic transmission mounting pad bolt	4

REMOVAL

The transmission does not have to be drained for this operation if it is not removed.

Place the vehicle on a lift.

Disconnect the battery.

Remove the front wheels.

Remove the driveshaft roll pins (tool B.Vi. 31-01).

Disconnect the track rod end (tool T.Av. 476).

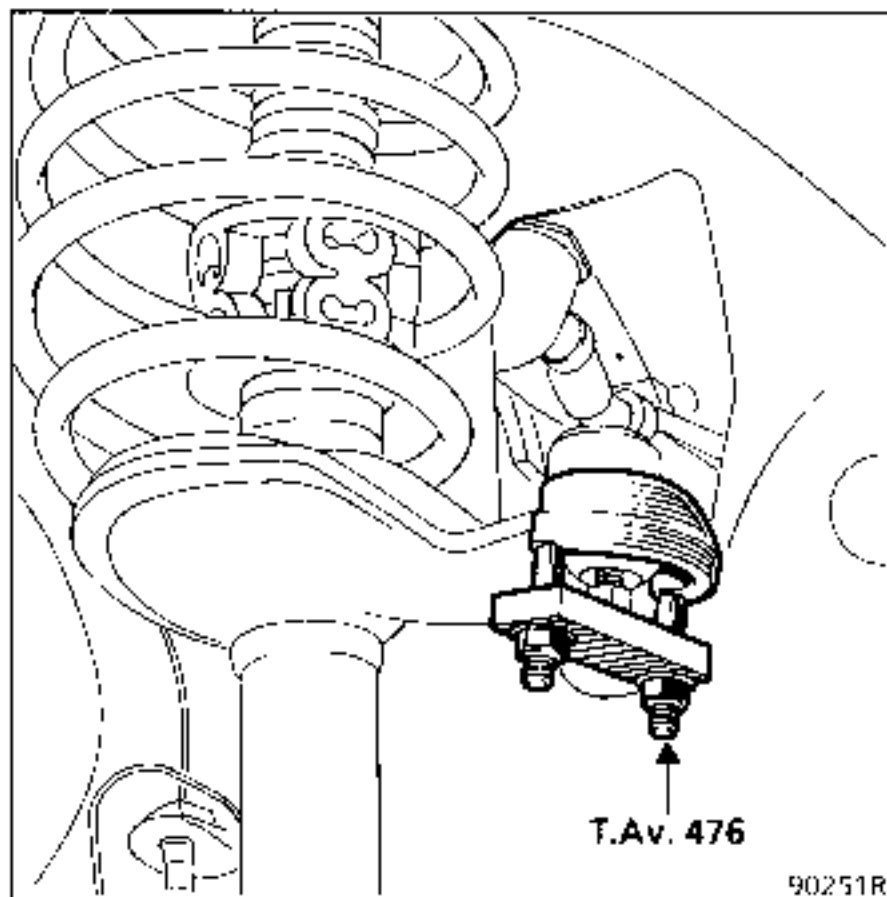

On the right and left hand sides, slacken the lower shock absorber base mounting bolts (2) and remove the upper bolts (1).

NOTE : the bolts have a splined section so a mallet must be used to remove them.

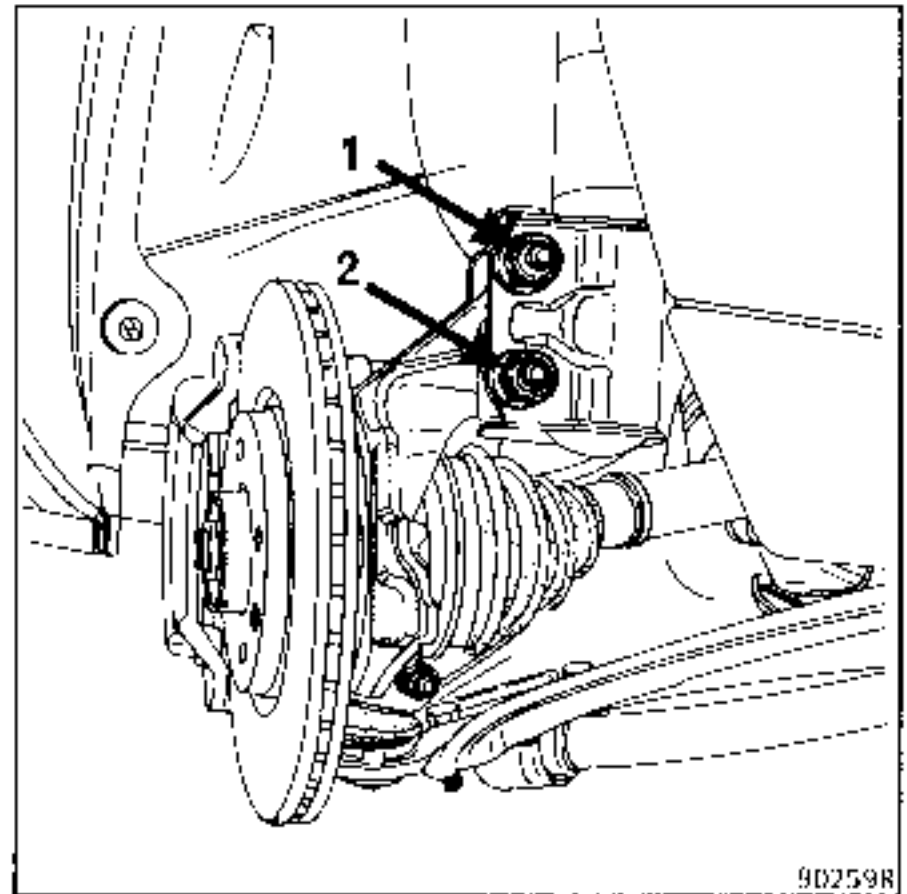

Tilt the stub axle carriers and release the driveshafts.

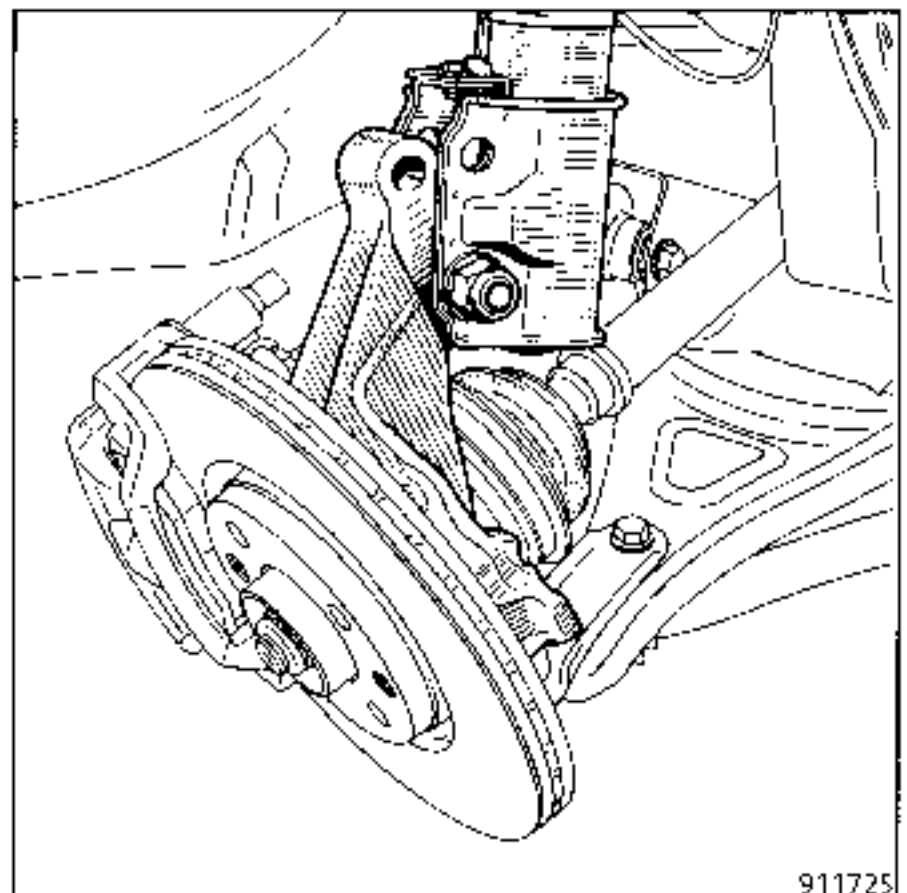

Remove:

- the two cross members, one at the rear and one under the transmission,

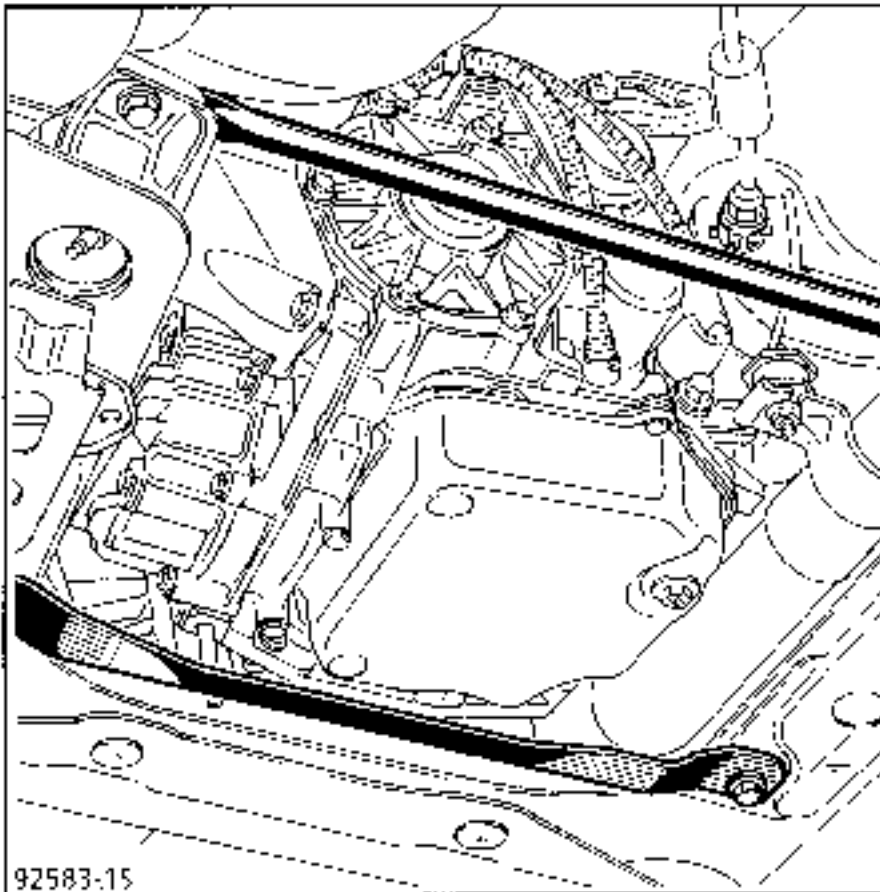

- the primary exhaust pipe,
- the starter motor.

Remove the three bolts securing the converter / drive plate assembly (tool **Mot. 582**).

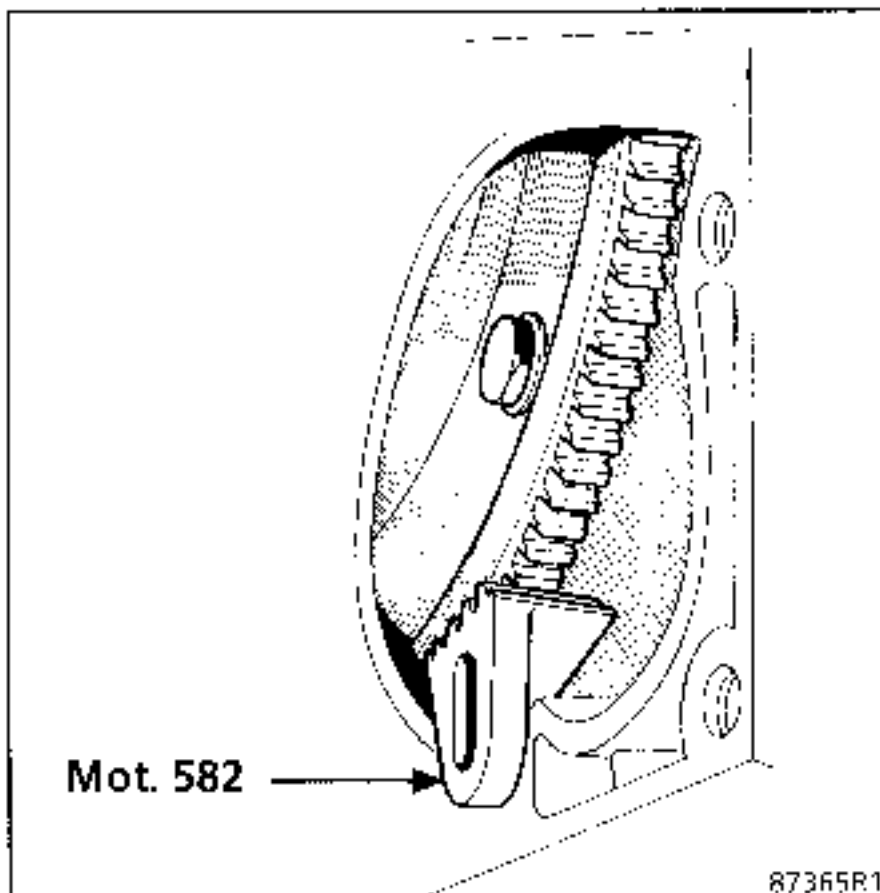

Remove:

- the engine speed sensors,
- the speedo cable.

Disconnect:

- the oil cooler water pipes, using tool **Mot. 43-01** or **M.S. 583**,

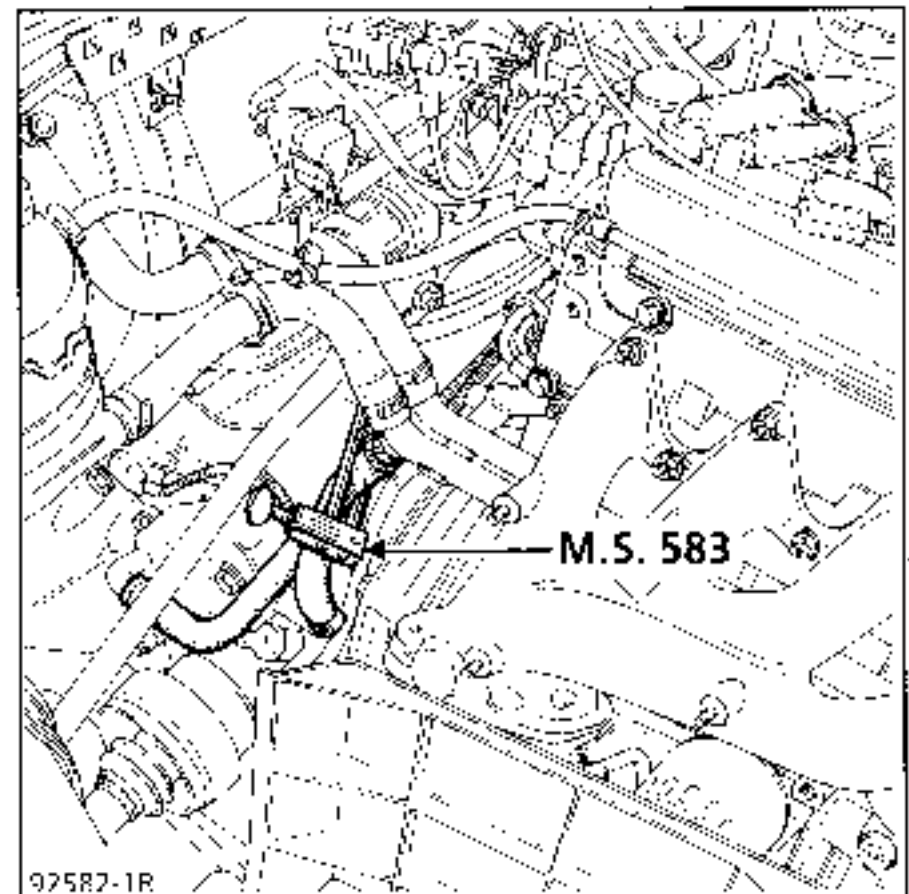

- the earth strap,
- the gear control cable (ball joint).

Fit the transmission support.

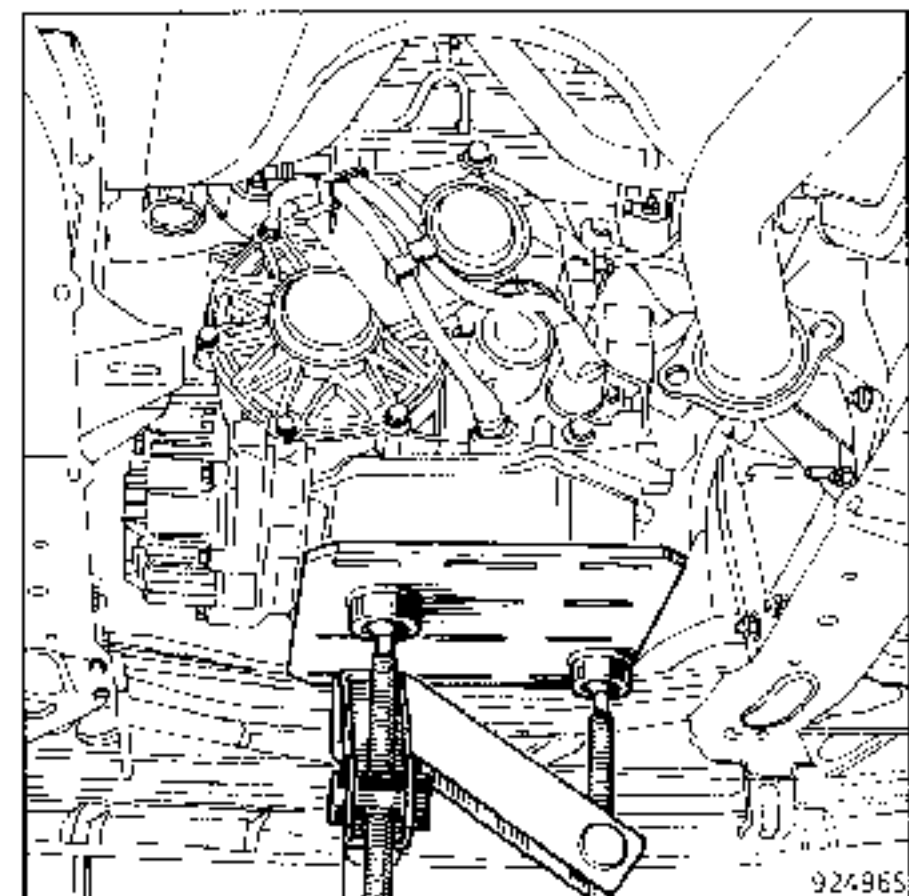

Remove:

- the left and right hand transmission mounting pads (the right hand mounting remains attached to the control cable; do not alter the adjustment of the control),
- the bolts mounting the transmission to the engine (at the edge).

Disconnect:

- all the computer connectors from the transmission and release the wiring the breather pipes.

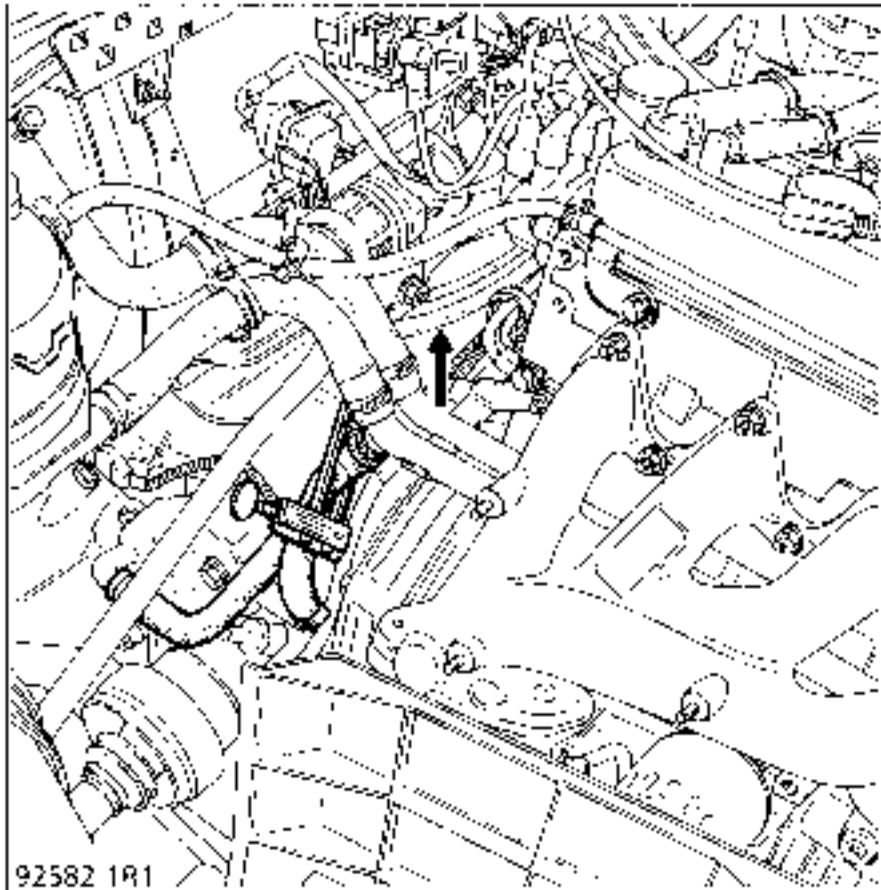

Push the converter back as far as it will go at the transmission end and release the driveshaft by moving it back straight along the engine centre line.

Fit the converter locking tool.

REFITTING

Before refitting the automatic transmission to the vehicle, check the centring dowels (A) and (B) are present on the engine block.

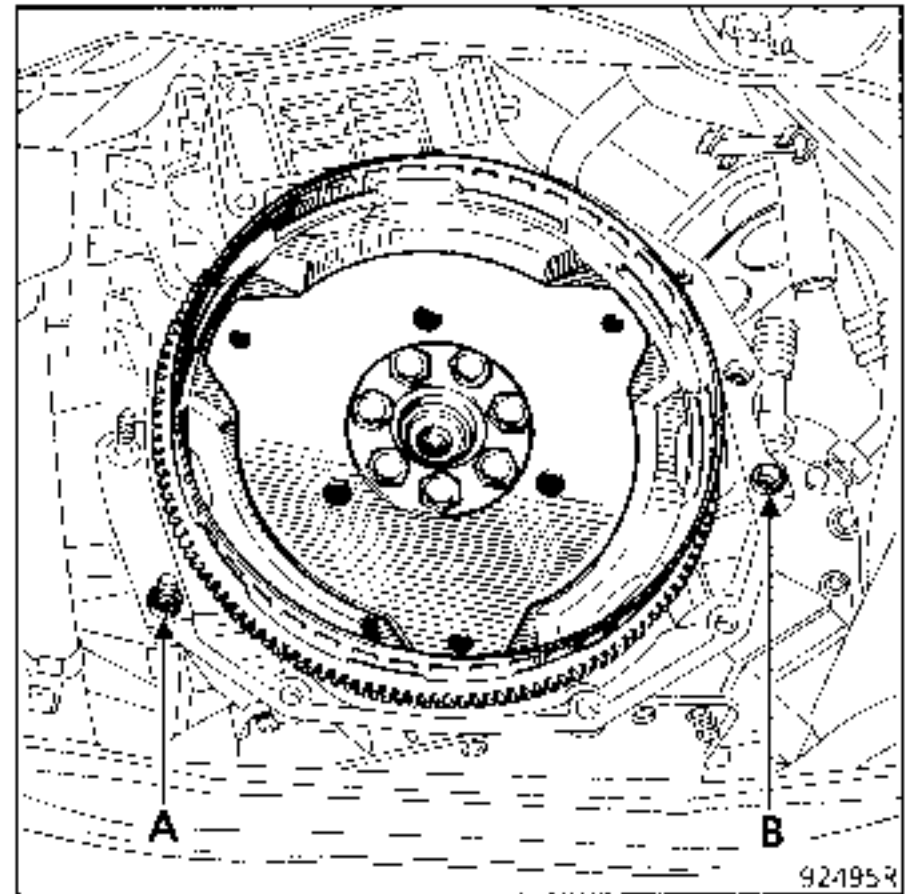

Lubricate the device centring the converter on the crankshaft and the sunwheel splines using **MOLYKOTE BR2**.

Place the converter in its initial position in relation to the drive plate.

The converter and the drive plate are not marked, but if they are not fitted correctly, it will be very difficult to rotate one in relation to the other.

Assemble the engine and transmission.

Tighten the drive plate mounting bolts on the converter to a torque of **3.5 daN.m**.

DO NOT USE THE IGNITION SENSOR TARGET TO IMMOBILISE THE DRIVE PLATE / CONVERTER ASSEMBLY.

Use tool **Mot. 582**.

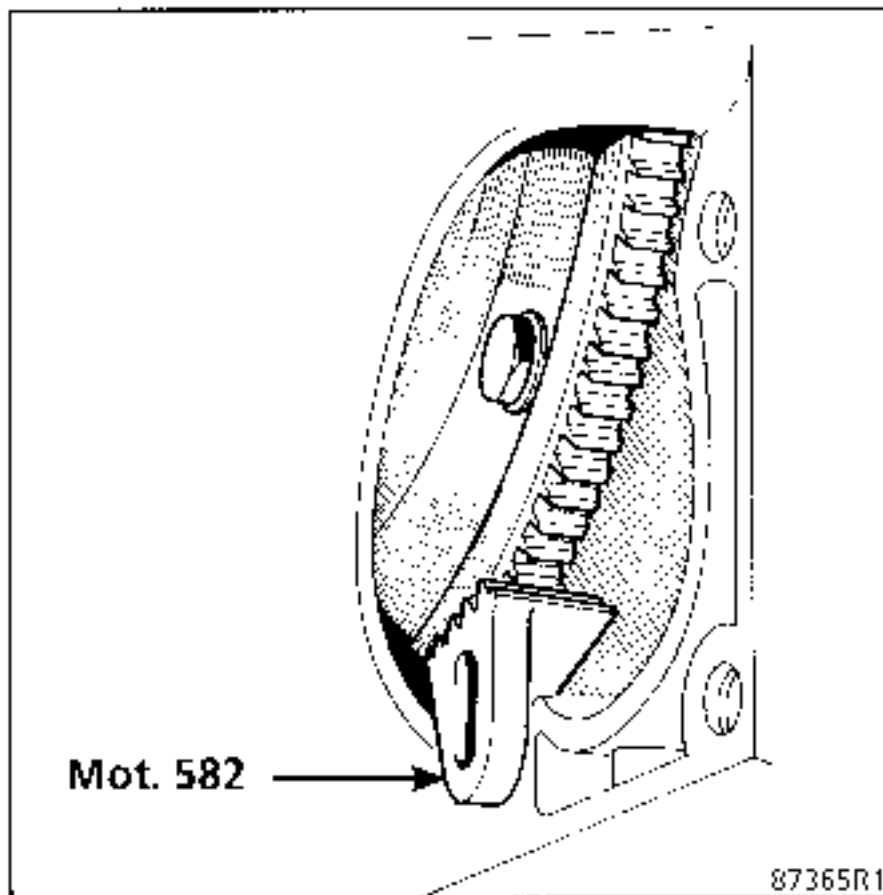

Refit:

- the starter motor (ensure the locating pin is present),
- the rear mounting pads and the transmission supports,
- the two cross members, one at the rear and one under the transmission,
- the exhaust, before fitting the right hand driveshaft as assembly is easier.

Ensure the rubber washer is present which should be fitted between the end of the sunwheel and the bottom of the driveshaft yoke.

Position the driveshaft in relation to the sunwheel.

Tilt the stub axle carriers and engage the driveshafts into the sunwheels.

Using the angled pin **B.Vi. 31-01** to align the holes.

Fit new roll pins and seal the ends (**RHODORSEAL 5661**).

Refit the front driveshafts and tighten the nuts to the recommended torques.

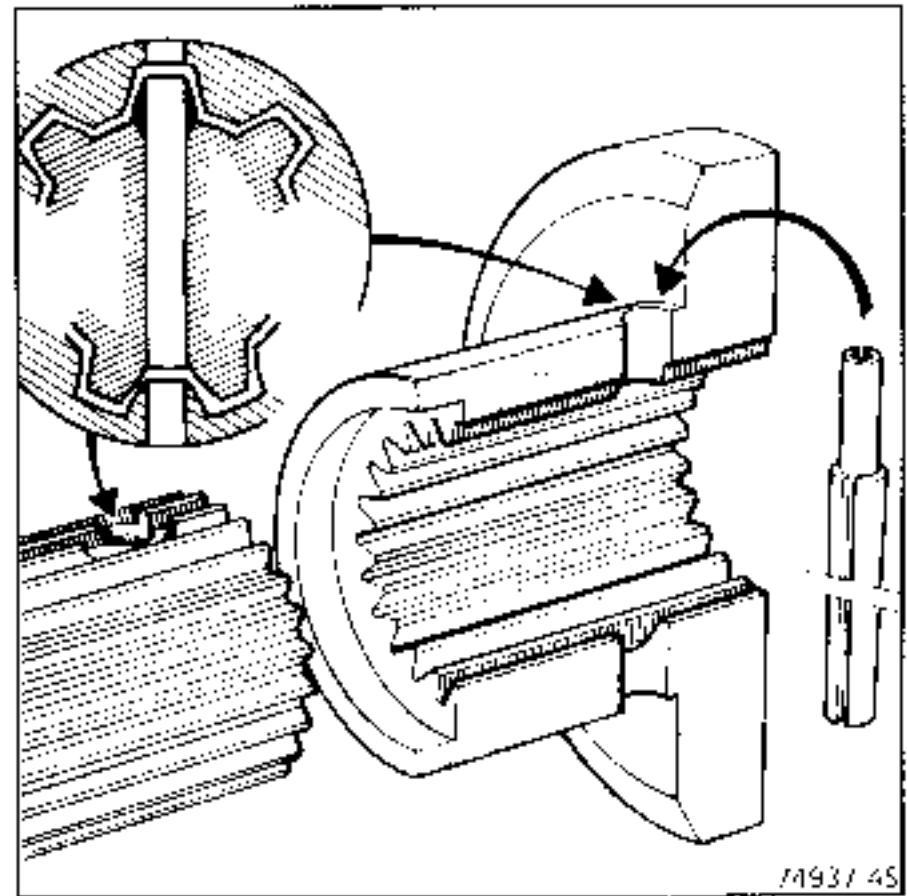

NOTE : An inlet chamfer on the sunwheels makes fitting the new roll pins easier.

Reconnect:

- the engine speed sensor and speedo sensor,
- the earth strap.

Refit and check the adjustment of the control (see corresponding section).

Reconnect:

- all the electrical connections,
- the oil cooler and the breather.

When refitting the wiring, pay particular attention to the correct routing of each of the leads to ensure that none of them interferes with a rotating or hot part (for example the exhaust).

Top up the engine cooling system.

After starting the engine, check the automatic transmission oil level.

REMOVAL - REFITTING

SPECIAL TOOLING REQUIRED

Mot. 582	Locking tool
Mot. 1202	Hose clamp pliers

TIGHTENING TORQUES (in daN.m)



Shock absorber base mounting bolt	11
Driveshaft mounting bolt	3.5
Wheel bolts	9
Front support mounting nut	4
Rear support mounting bolt	6.5
Transmission mounting pad mounting bolt	2
Oil cooler mounting bolt	2.5
Drive plate mounting bolt on converter	1.5
Bolt at edge of automatic transmission	4

Put the vehicle on a 2 post lift.

Remove:

- the bonnet,
- the front wheels,
- the left side deflector , (1 bolt and 3 rivets).

Disconnect the connector (1) for the oxygen sensor.

Remove the downpipe.

Retain the seal for the flange (2).

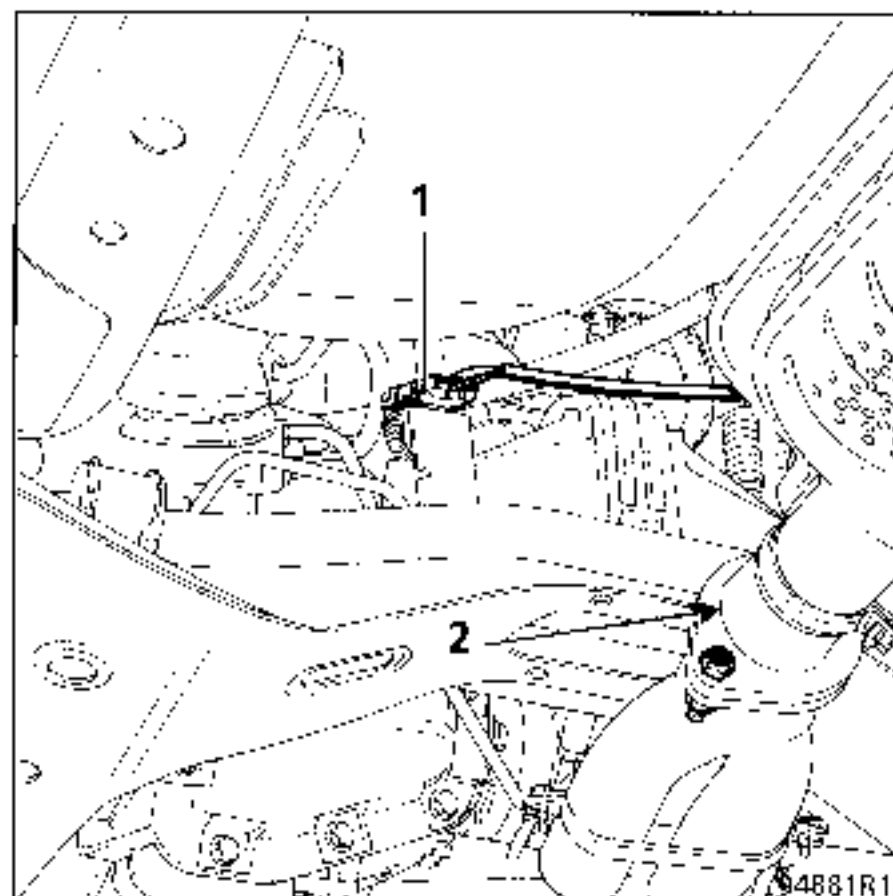

Remove the driveshaft mounting bolts on the sunwheel output flanges.

- **1st assembly:** hexagonal head bolts

Use socket **FACOM J235** and a **6 mm** allen key end piece.

- **2nd assembly:** 12 sided head bolts

Use socket **FACOM SV.8L** 12 sided allen key.

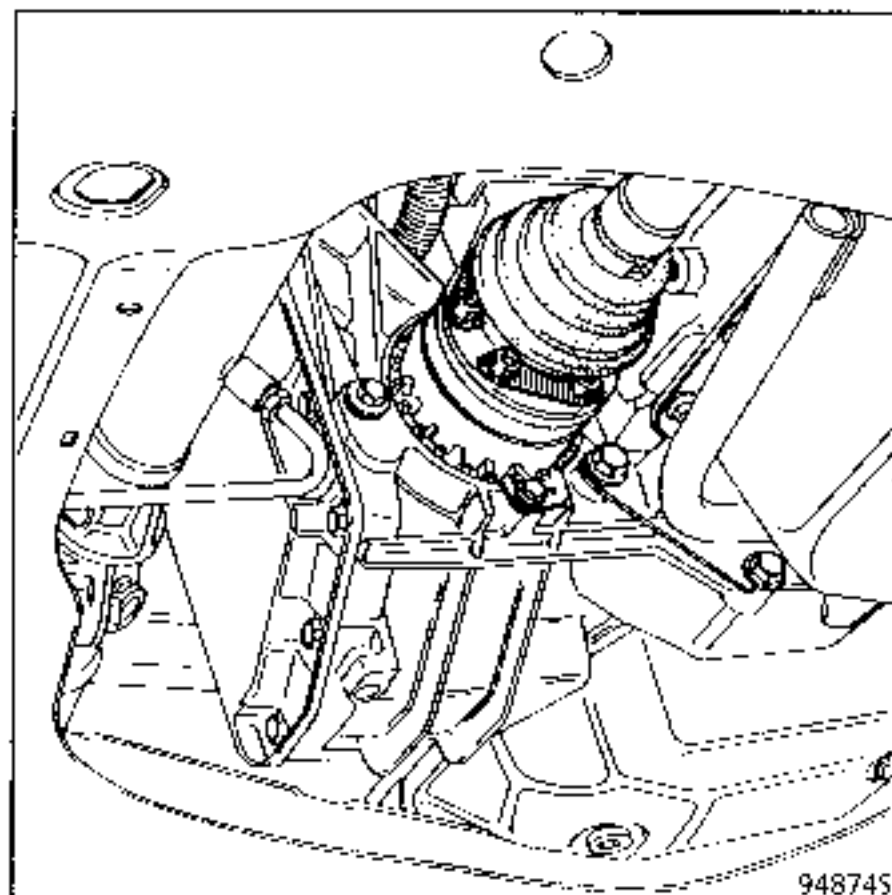

On each side of the vehicle, remove the upper bolt (3) and slacken the lower bolt (4).

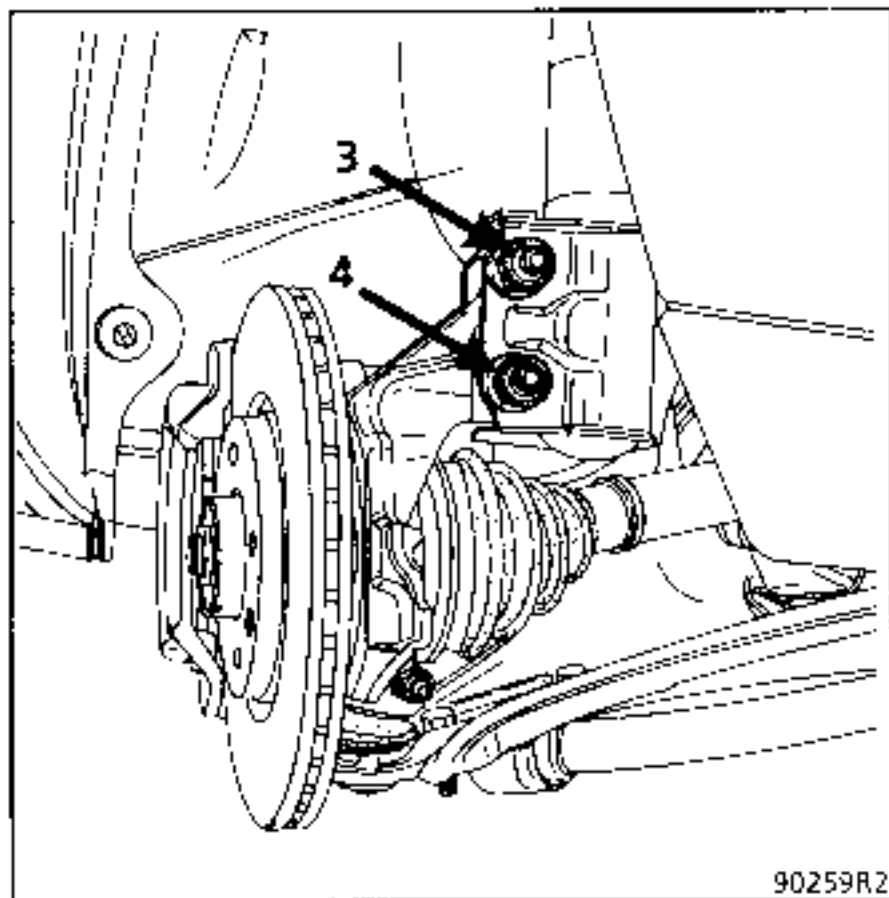

Release the driveshafts at the side.

Remove the mounting nut for the front automatic transmission mounting pad.

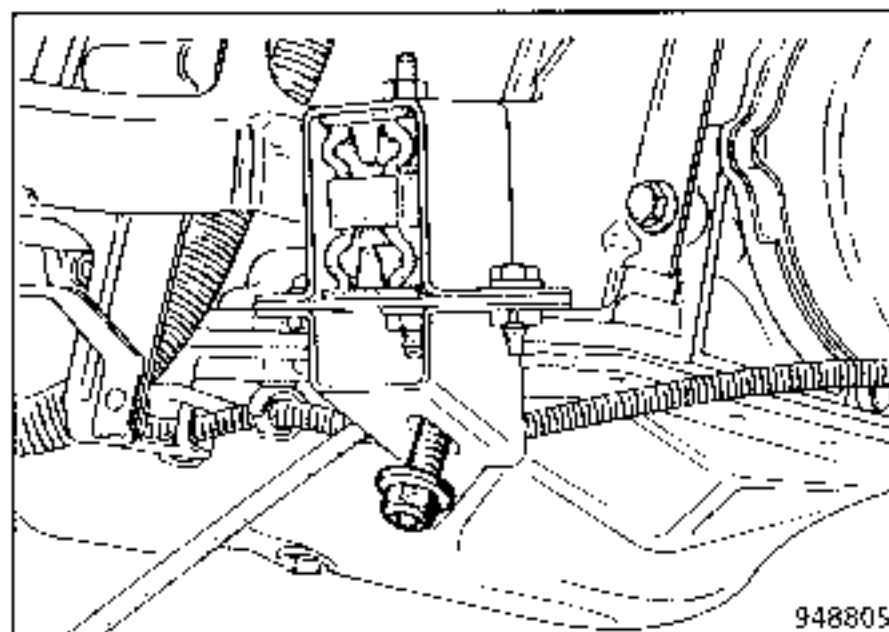

Remove the mounting nut for the front engine mounting pad.

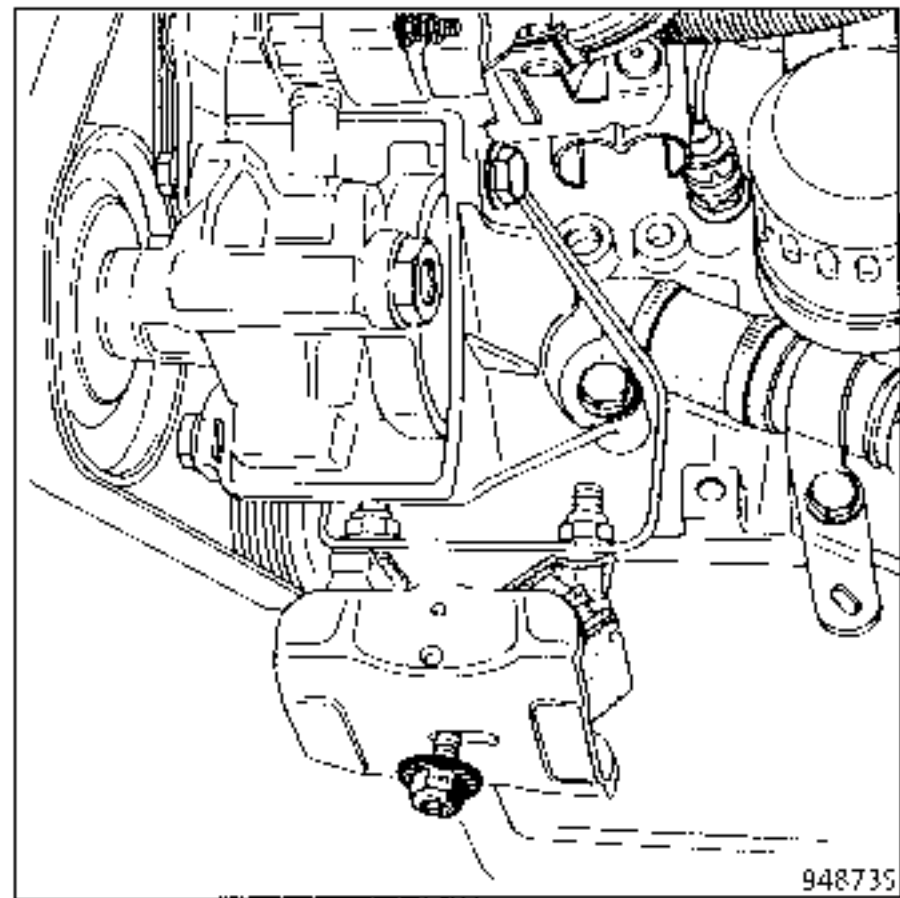

Remove:

- the battery,
- the air filter,
- the injection computer,
- the automatic transmission computer (6).

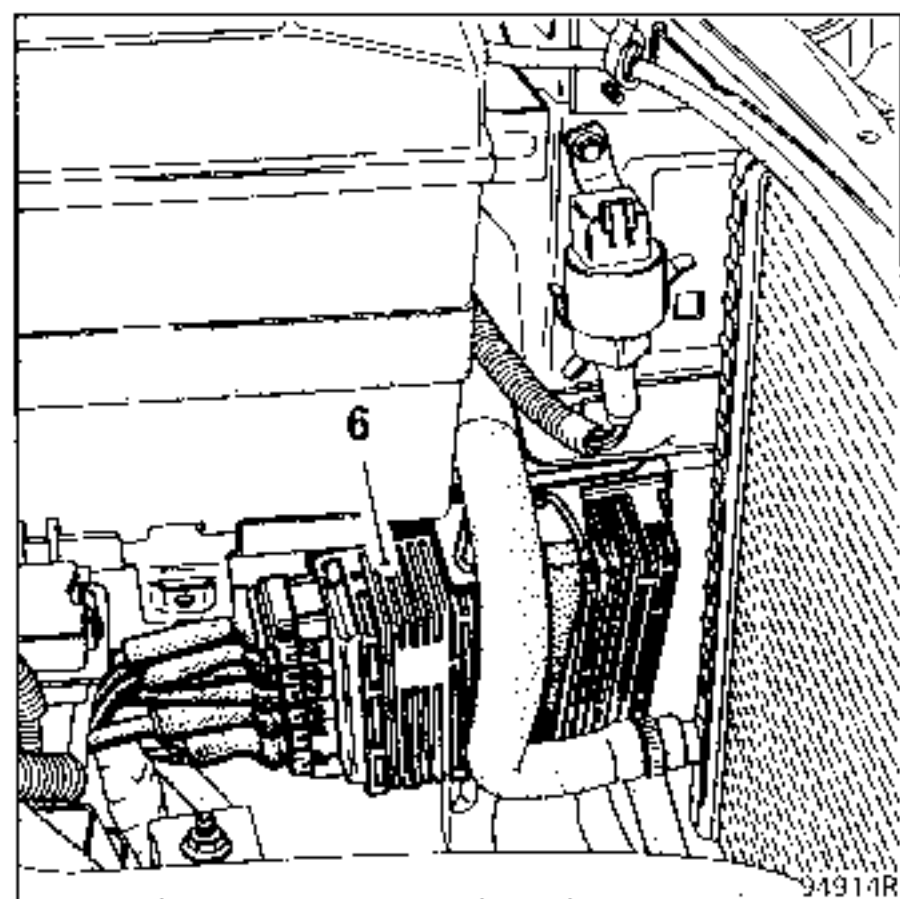

Remove the battery mounting, after disconnecting:

- the fuel pump relay (1),
- the injection locking relay (2),
- the A.T. prevention relay (3),
- the starting safety relay (4).

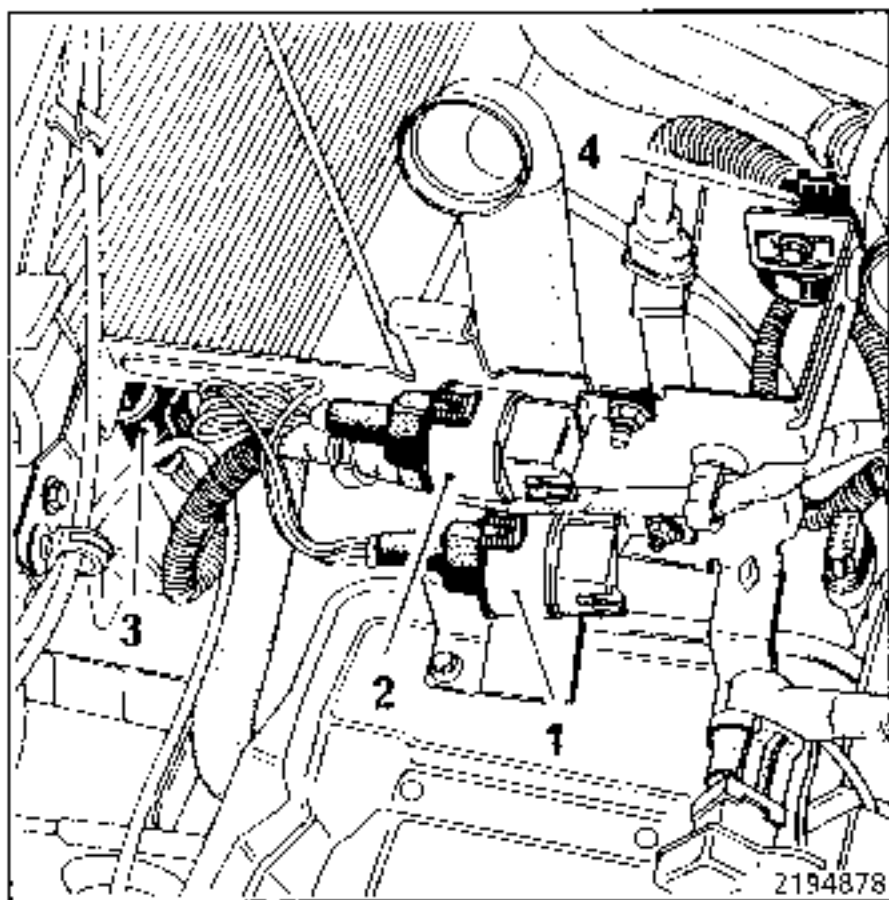

Remove the expansion bottle and the power assisted steering reservoir.

Remove the M.P.A. unit and the mounting bolts (11) for the expansion bottle mounting.

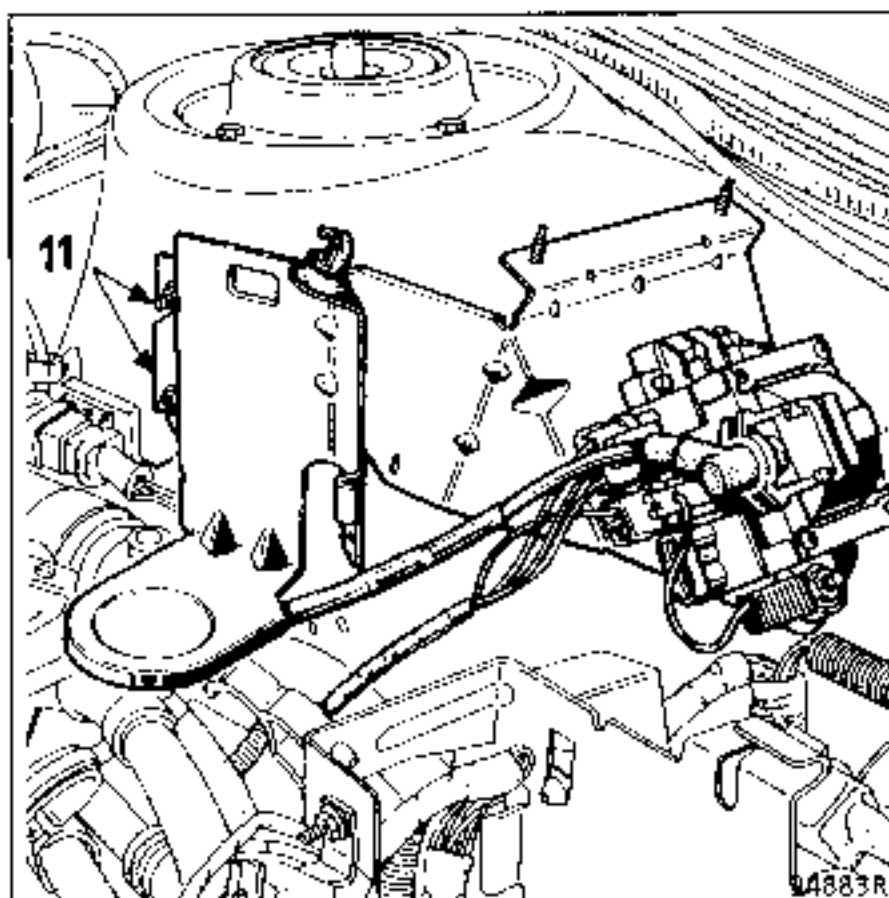

On the right hand side of the vehicle

Remove:

- the accelerator cable,
- the vacuum pipes (1) and (2) for the solenoid valve and the canister bleed valve,
- the vacuum pipe (3) for the pressure sensor.

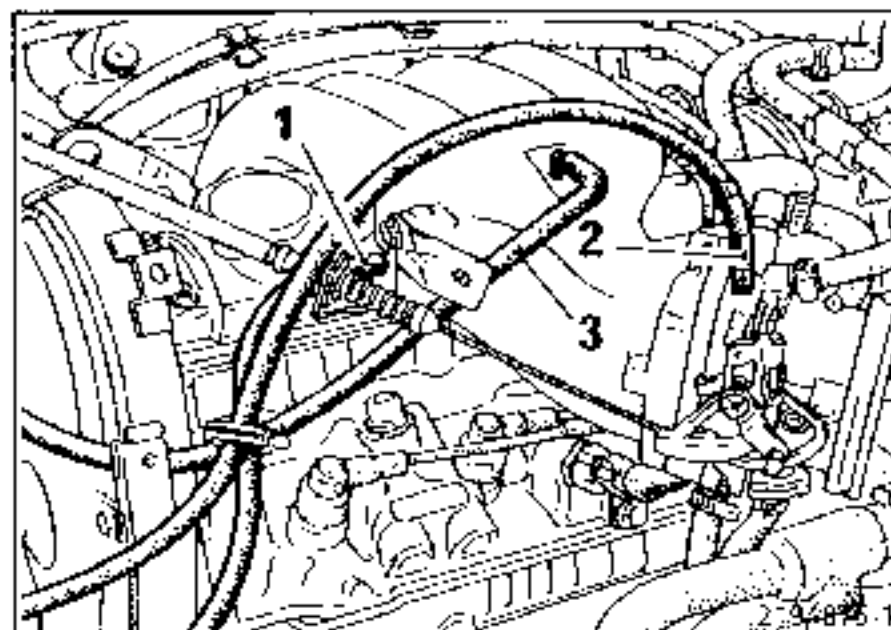

Disconnect the pressure sensor connector.

Disconnect the connector for the EGR solenoid valve.

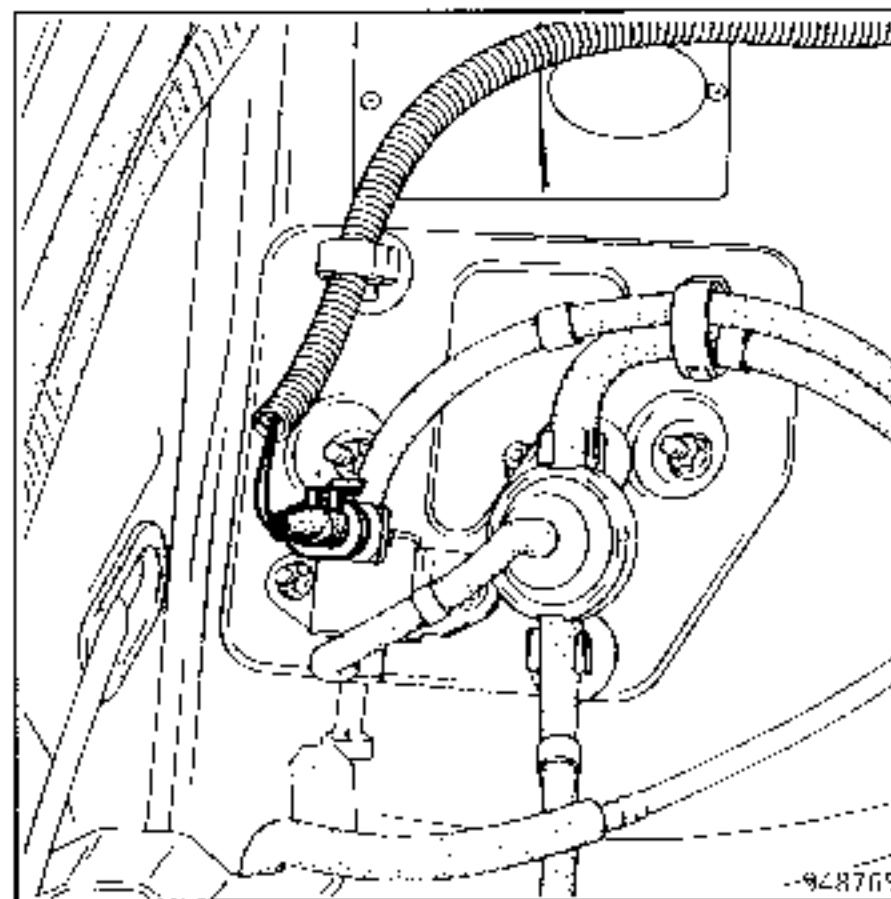

Disconnect the connector for the fan assembly wiring (1) and the oil level sensor connector (2).

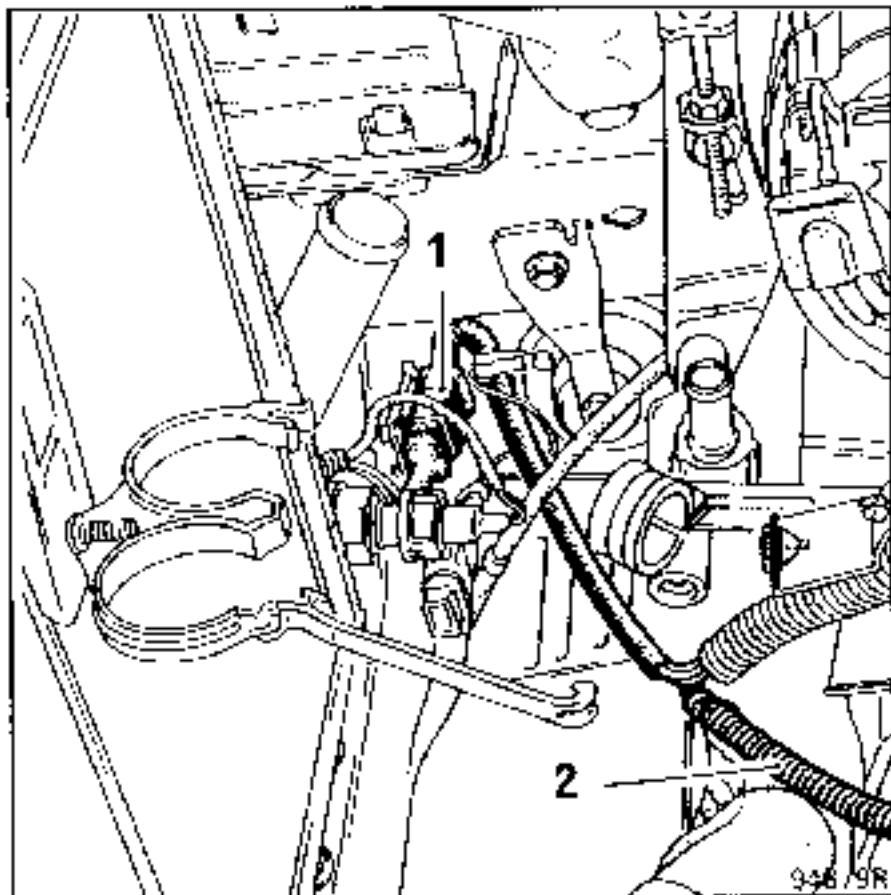

On the left hand side of the vehicle

Disconnect:

- the connector for the connection on the side member,
- the water pump relay (1),
- the reversing lights relay (2),
- the water pump diodes unit (3),
- the connector (4) for the water pump,
- the heating connector (5).

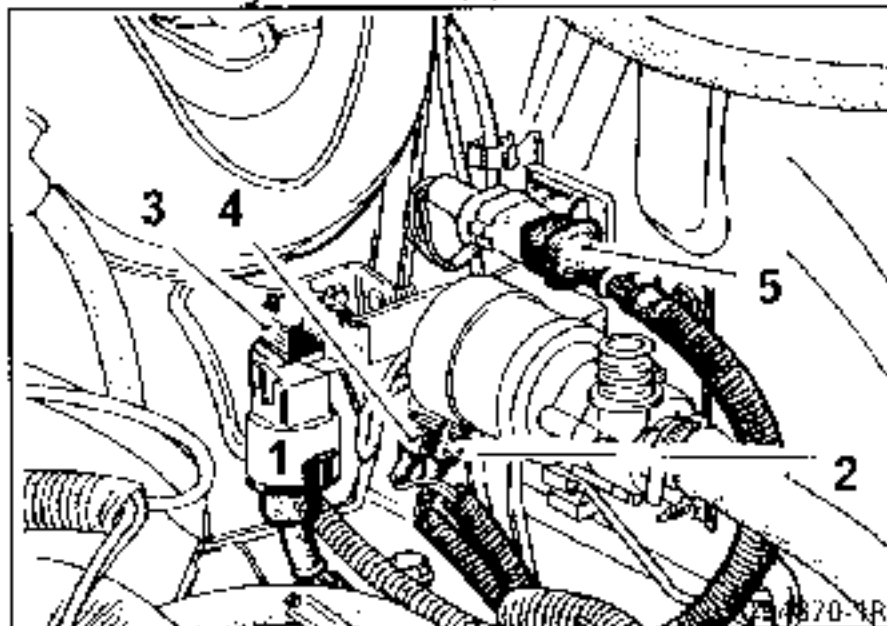

Drain the cooling circuit by disconnecting the upper and lower radiator hoses.

Remove the upper hose from the water pump.

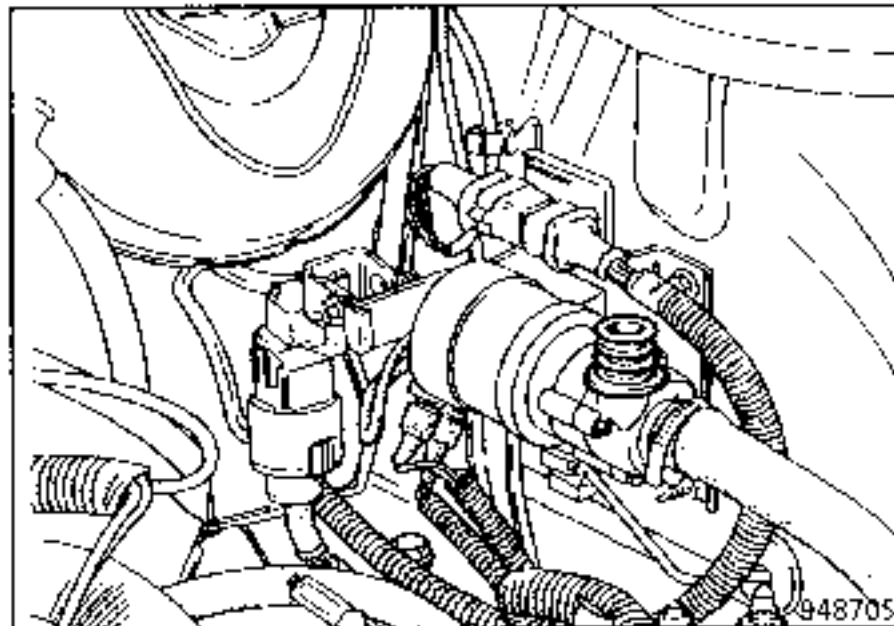

Remove the two heating hoses:

- on the engine connection,
- on the expansion bottle.

Remove the brake servo vacuum pipe.

Remove:

- the A.T. control cable,
- the speedo cable (1) after unscrewing it from the automatic transmission.

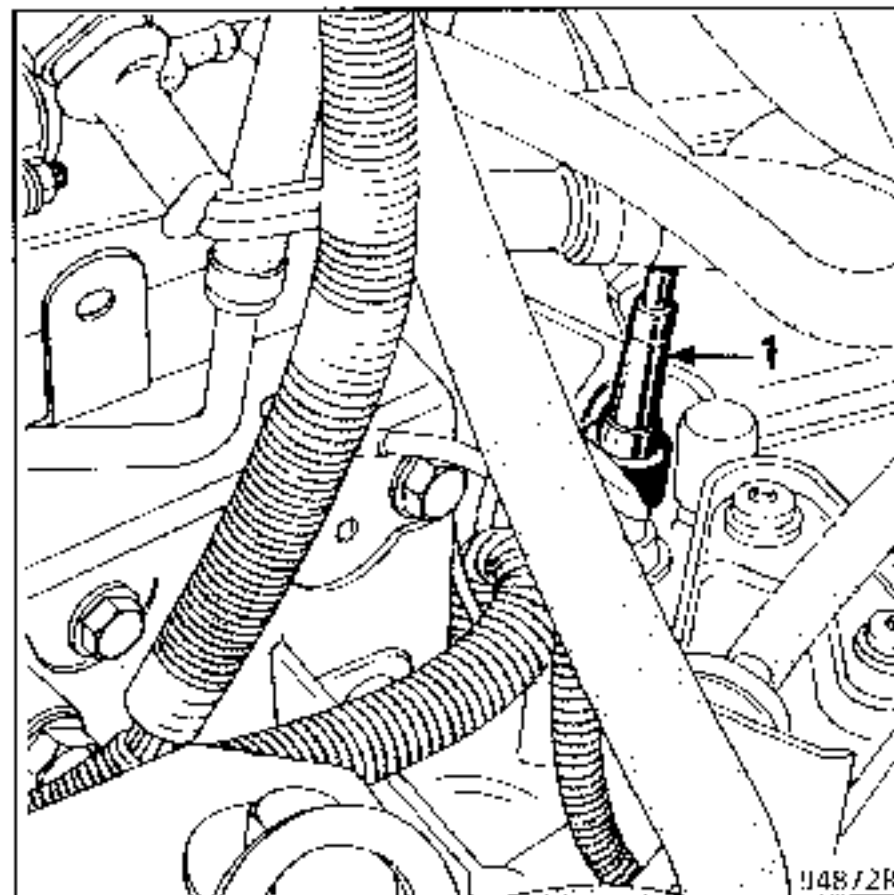

Remove the fuel pipes and the connector (1) for the kickdown switch.

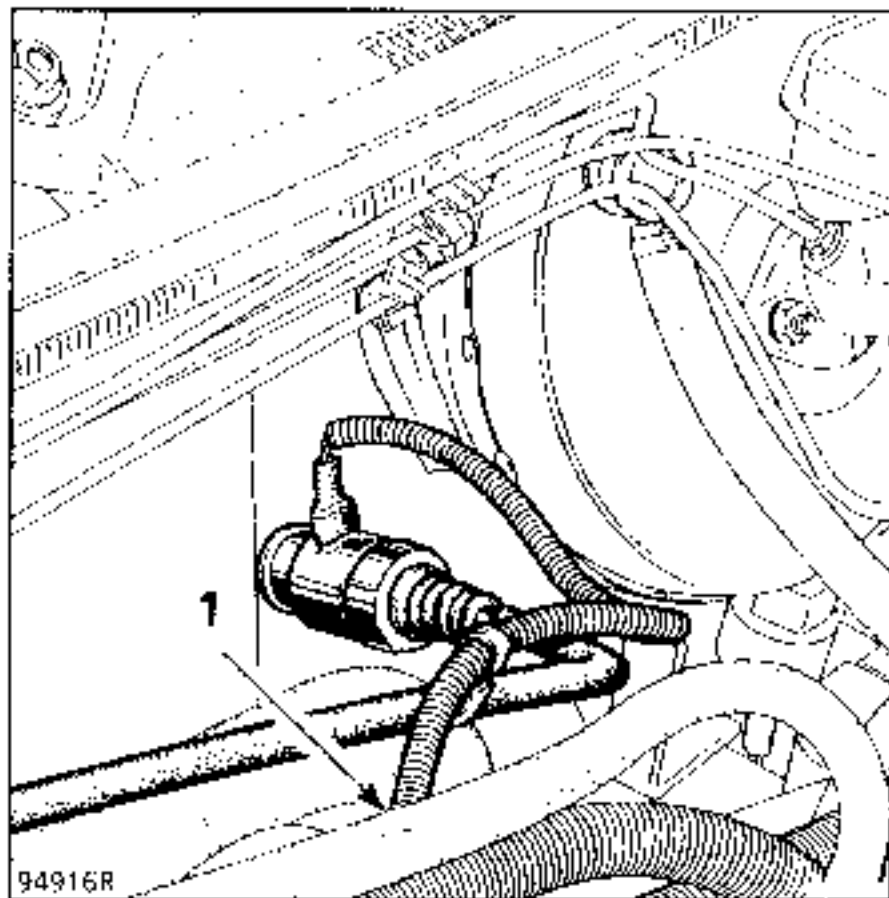

Remove the earth wire on the automatic transmission.

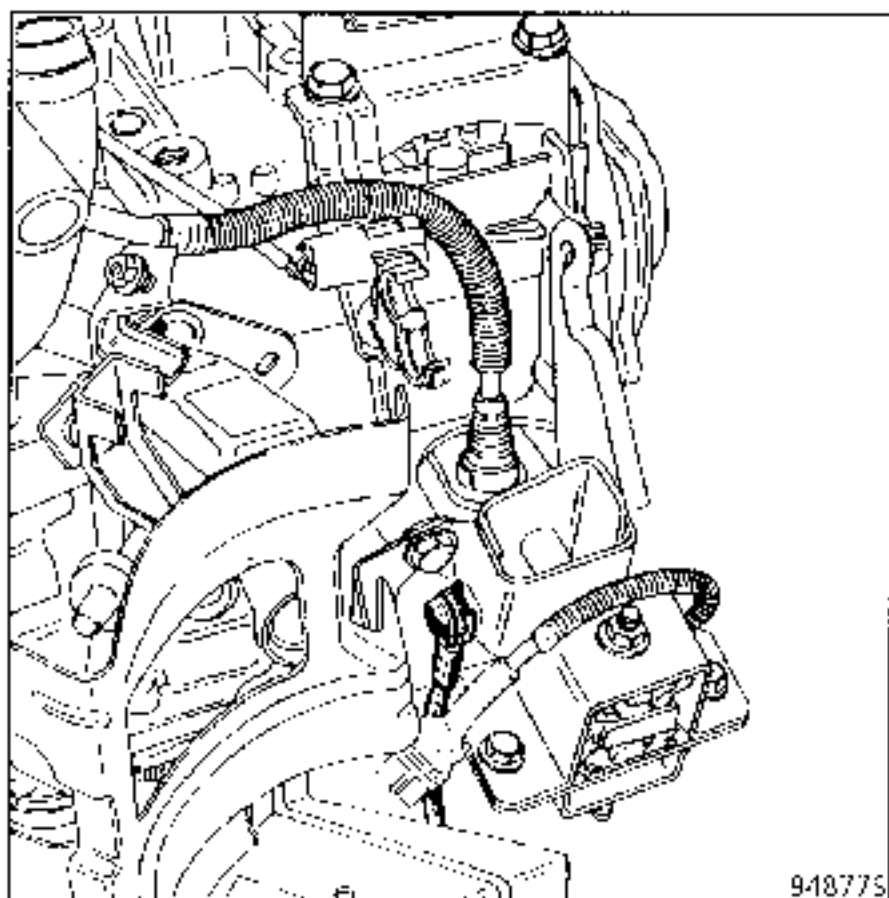

Remove the power assisted steering pipes.

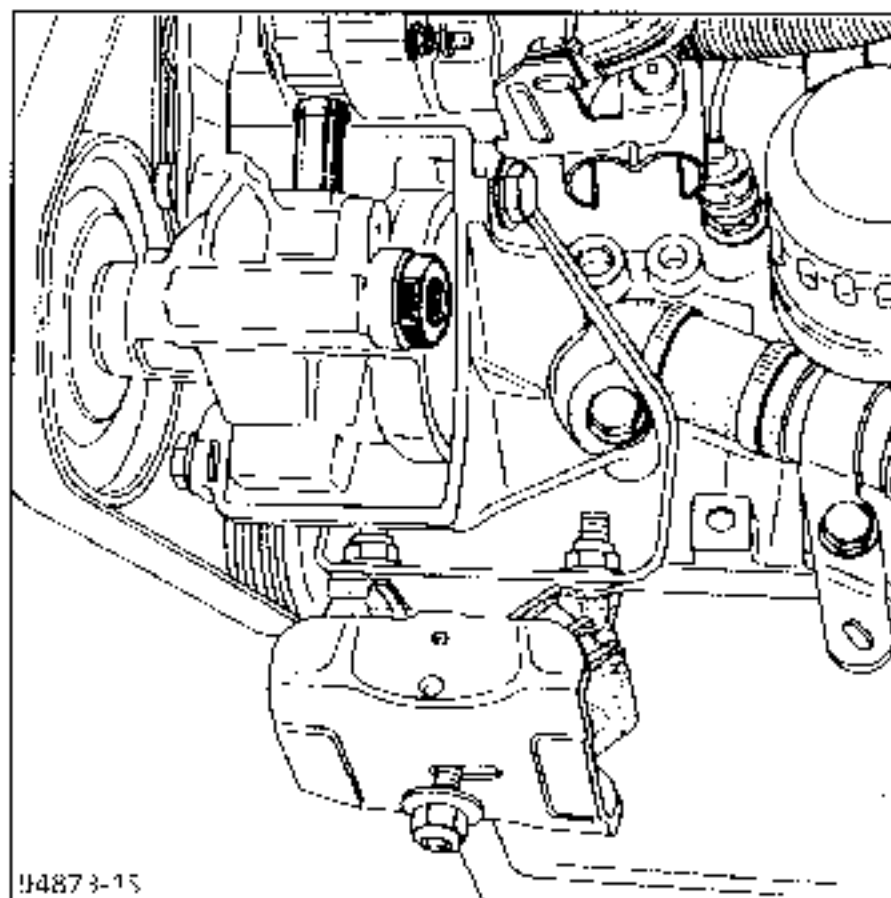

Fit the load positioning tool (eg- **NAUDER 1805**), and tension the lifting chains.

Take the weight of the engine and automatic transmission assembly.

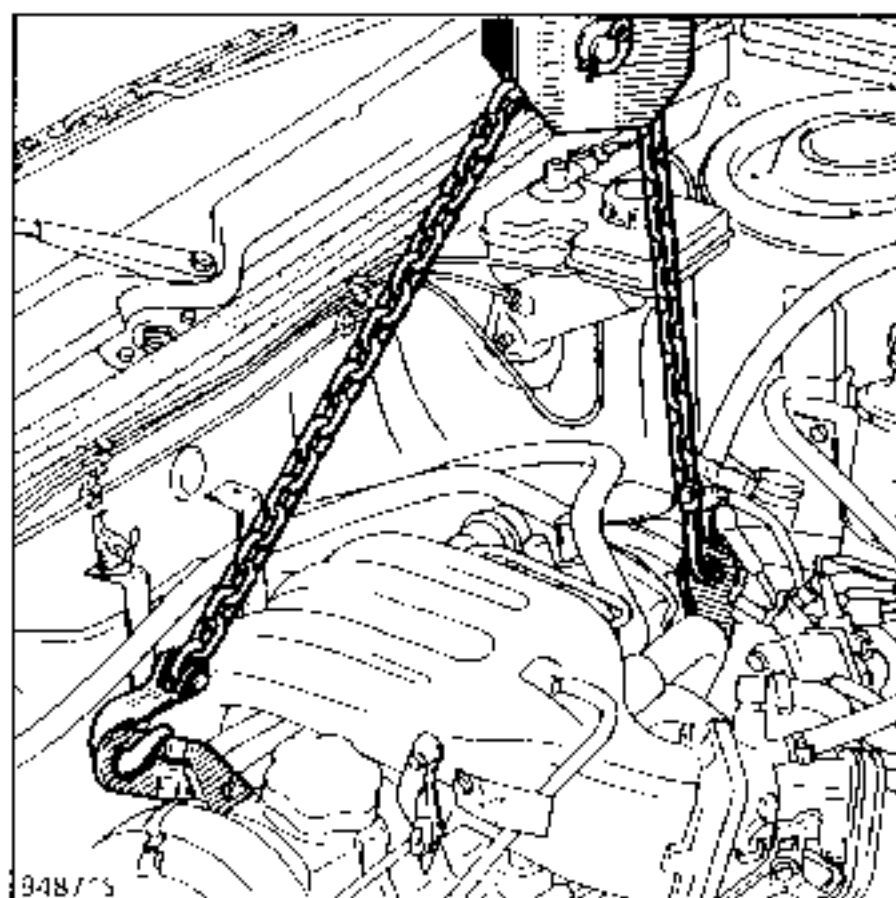

Remove the rear mounting bolt.

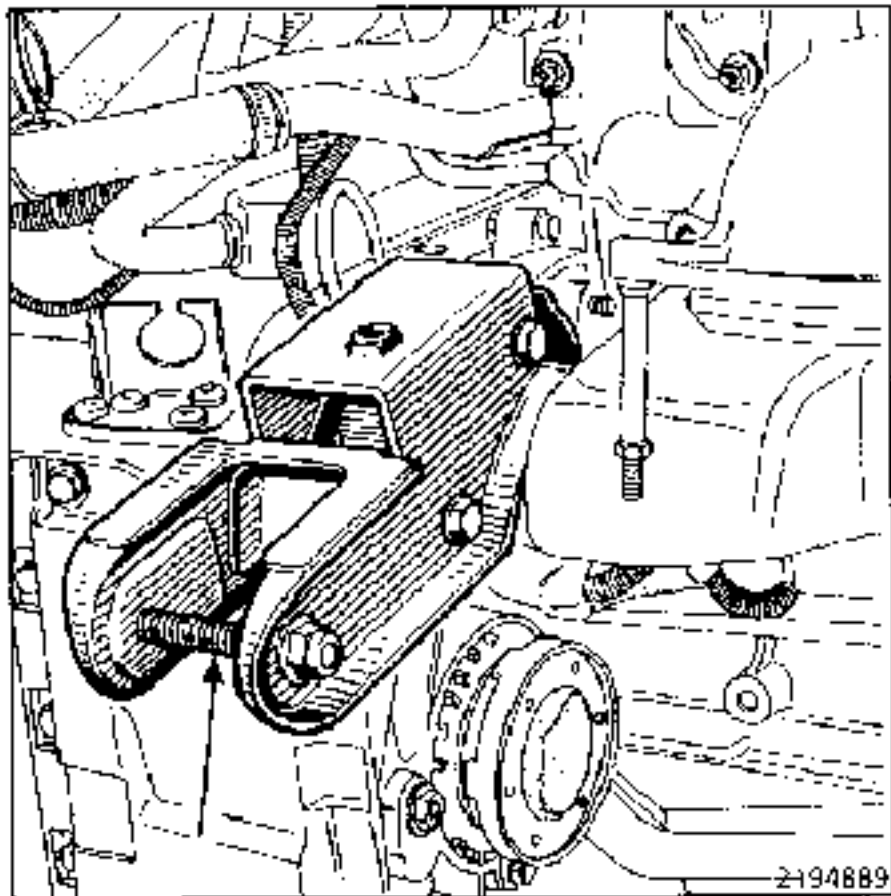

Remove the automatic transmission mounting pad. To do this, remove:

- the three bolts (1) on the automatic transmission,
- the two bolts (2) on the side member,
- slacken, but do not remove the two bolts (3) on the side member.

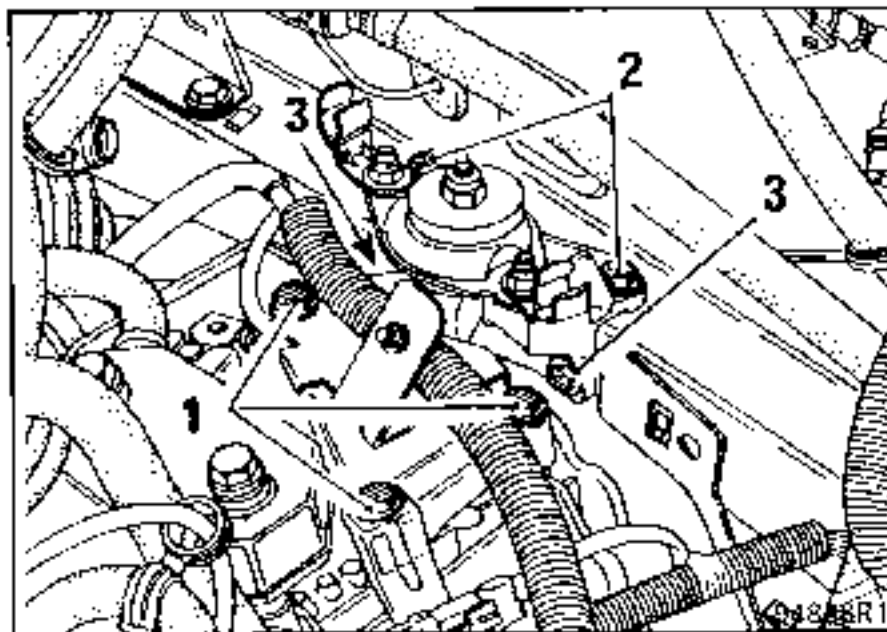

Remove the engine and automatic transmission assembly from the engine compartment.

Remove:

- the converter protective plate.

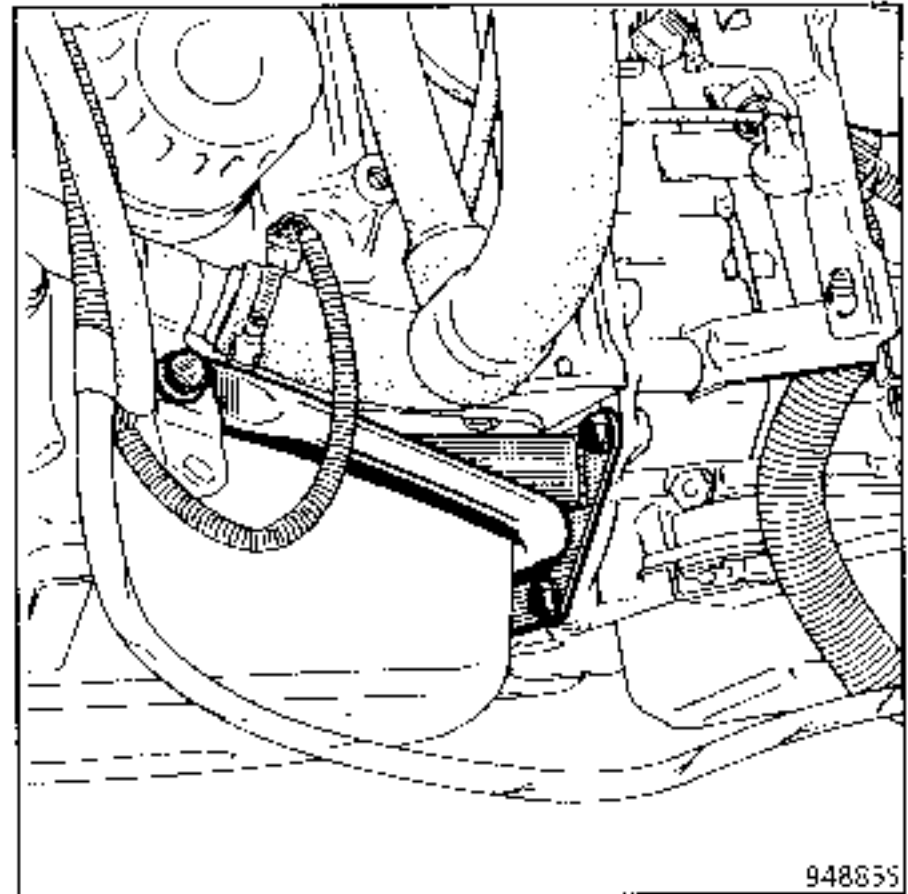

Fit the locking tool Mot. 582 and remove the three nuts mounting the drive plate to the converter.

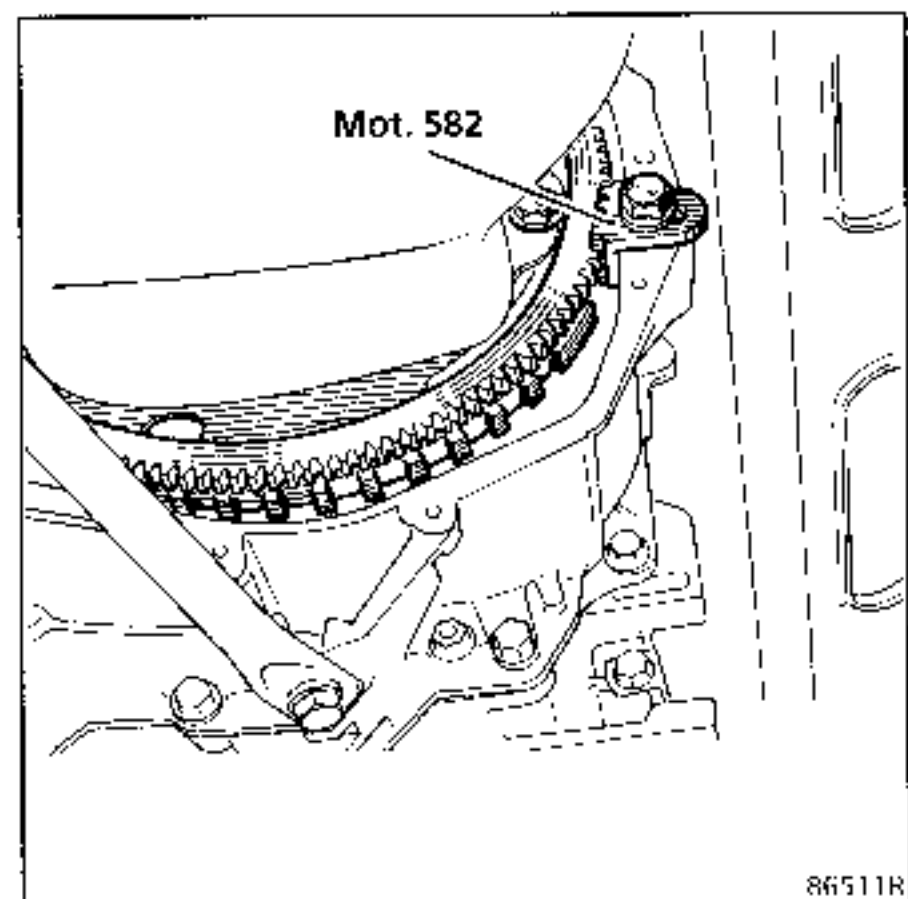

Remove:

- the starter motor heat shield,
- the starter motor,

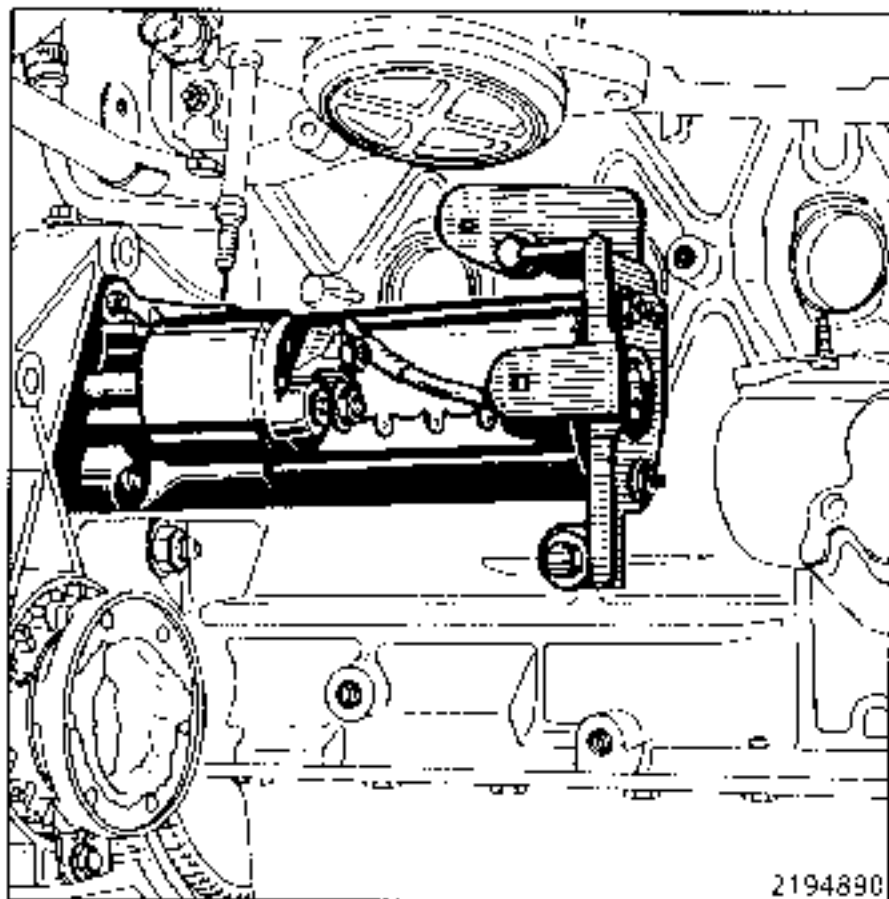

the oil cooler.

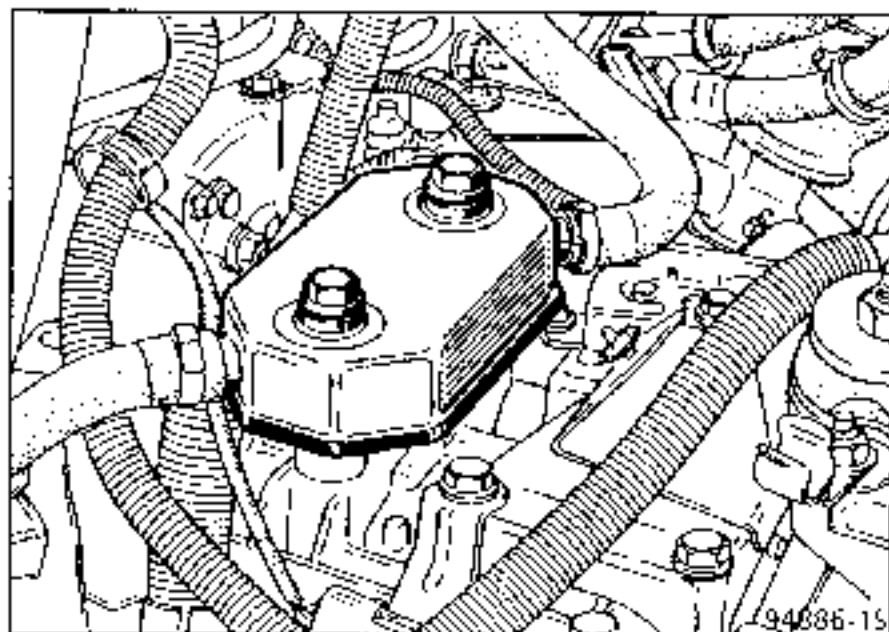

Release the wiring.

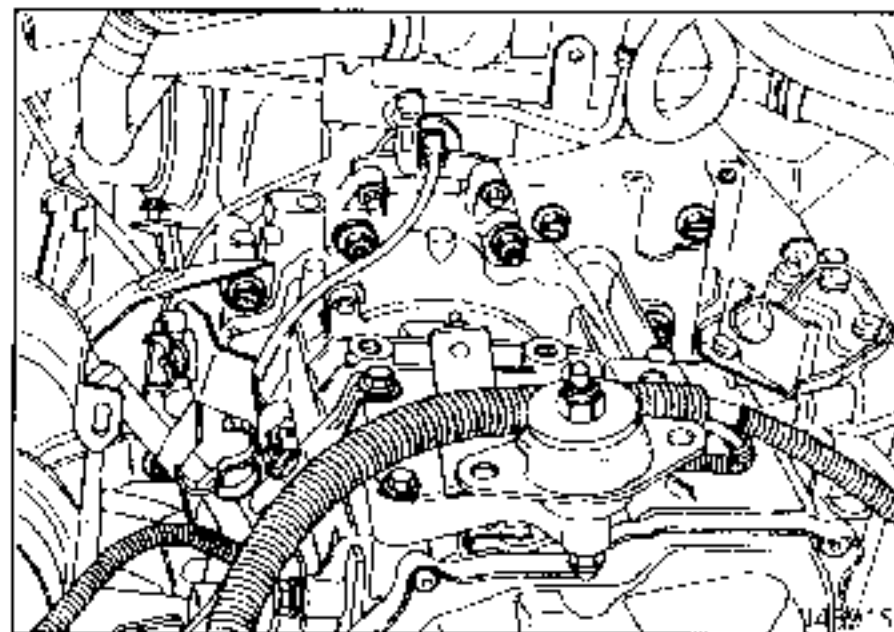

Remove the bolts mounting the automatic transmission to the engine.

Remove the engine mounting nut (1).

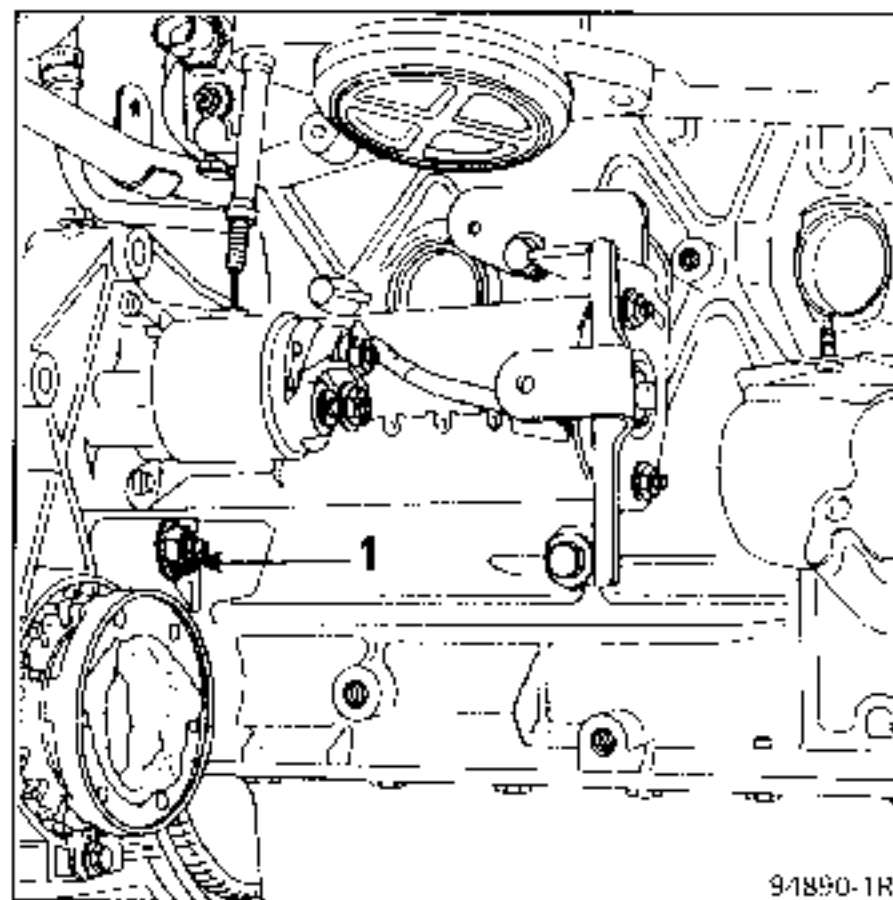

Release the transmission from the engine taking care not to let the converter fall out.

REFITTING

Before refitting the automatic transmission to the vehicle, check the centring dowels (A) and (B) are present on the engine block.

Lubricate the device centring the converter on the crankshaft using **MOLYKOTE BR2**.

Fit the automatic transmission to the engine and tighten the nuts and bolts to a torque of **4 daN.m**.

Fit the drive plate nuts on the converter using **LOCTITE FRENBLOC** and tighten them to a torque of **1.5 daN.m**.

Refit:

- the oil cooler and tighten the bolts to a torque of **2.5 daN.m**,
- the starter motor,
- the converter protective plate.

Refit the engine and automatic transmission assembly back into the engine compartment.

Refitting is then the reverse of removal.

Special notes:

Before repositioning the driveshafts, fill the sun-wheel output flanges with **MOLYKOTE BR2** grease.

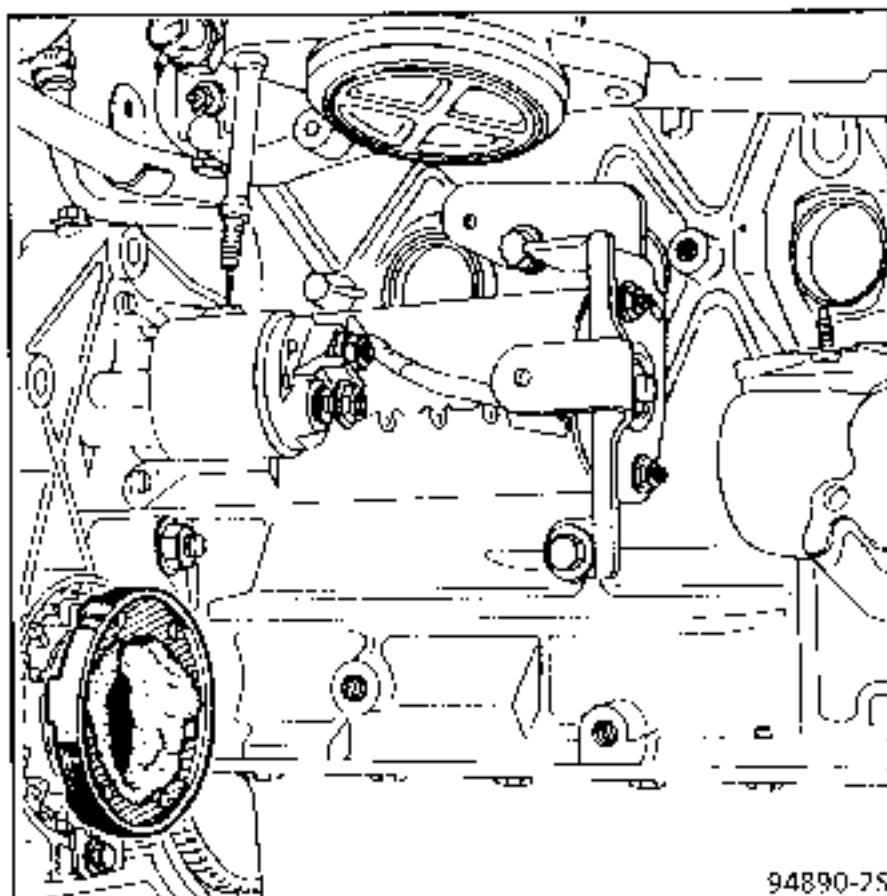

IMPORTANT : when refitting the accelerator cable, ensure the adjustment is correct as this affects the operation of the kickdown switch.

Refit the exhaust downpipe with a new gasket at the catalytic converter end and the sealing clip at the manifold end.

To ensure the exhaust pipe is correctly aligned, tighten the mountings at the manifold first and finish at the catalytic converter.

Carry out the following operations:

- fill and bleed the cooling circuit (sub-section 19),
- top up the level of the power assisted steering fluid,
- top up the level of the automatic transmission.

VERY IMPORTANT**REMEMBER TO VALIDATE FULL LOAD**

to reprogramme the load potentiometer travel into the automatic transmission computer.

SPECIAL TOOLING REQUIRED

Mot.	582	Locking tool
Mot.	1202	Hose clip pliers

TIGHTENING TORQUES (in daN.m)



Shock absorber base mounting bolt	11
Driveshaft mounting bolt	3.5
Wheel bolts	9
Mounting nut for front mounting	4
Mounting bolt for rear mounting	6.5
AT mounting pad mounting bolt	2
Oil cooler mounting bolt	2.5
Drive plate mounting bolt on converter	1.5
Automatic transmission edge mounting bolt	4

Put the vehicle on a 2 post lift.

Remove:

- the bonnet,
- the front wheels,
- the left side deflector, (1 bolt and 3 rivets).
- the exhaust downpipe.

Remove the driveshaft mounting bolts on the sunwheel output flanges.

- **1st assembly:** hexagonal head bolts

Use socket **FACOM J235** and a **6 mm** allen key end piece.

- **2nd assembly:** 12 sided head bolts

Use socket **FACOM SV.8L** 12 sided allen key.

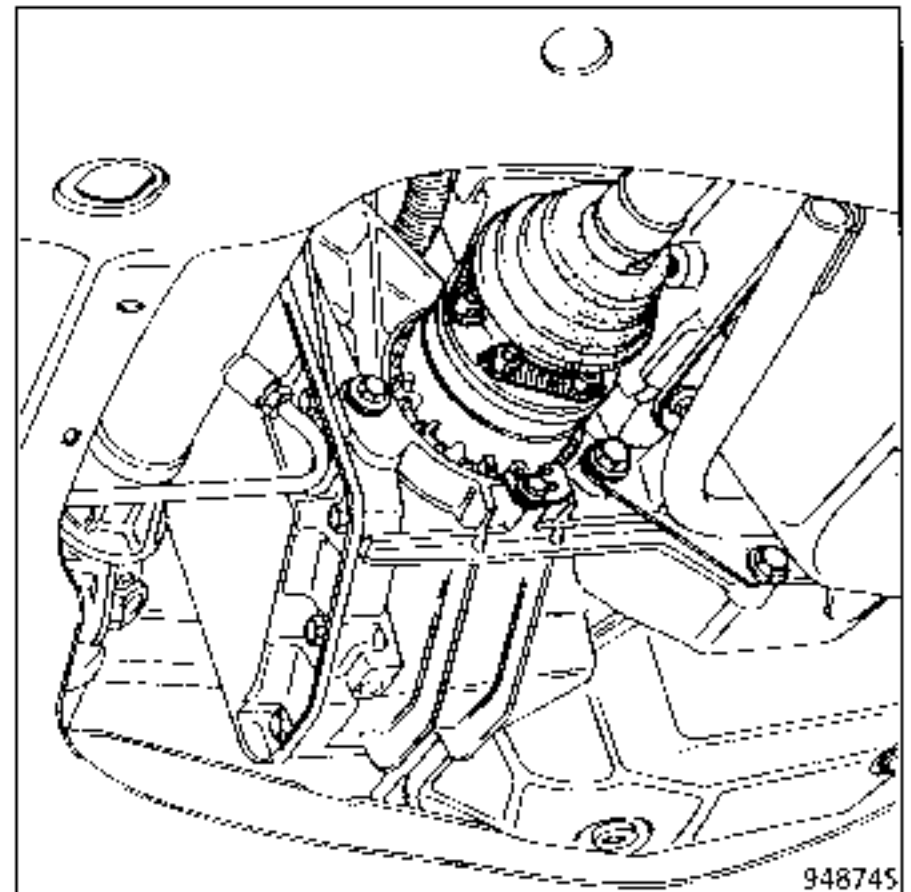

On each side of the vehicle, remove the upper bolt (3) and slacken the lower bolt (4).

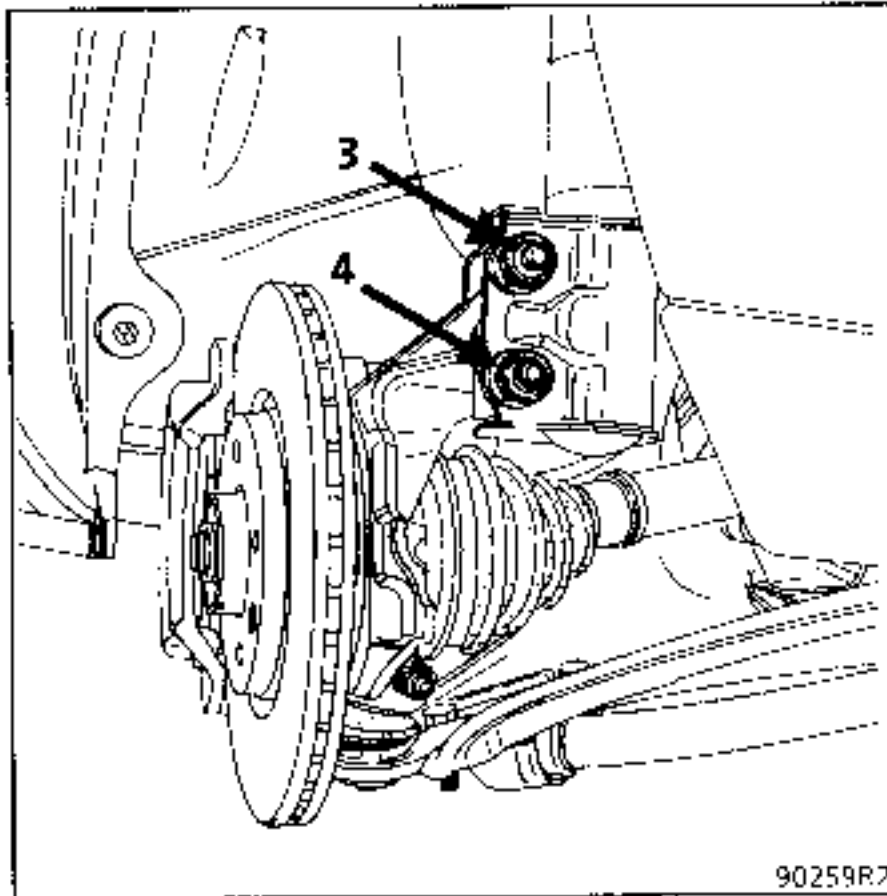

Release the driveshafts at the side.

Remove the mounting nut for the front automatic transmission mounting pad.

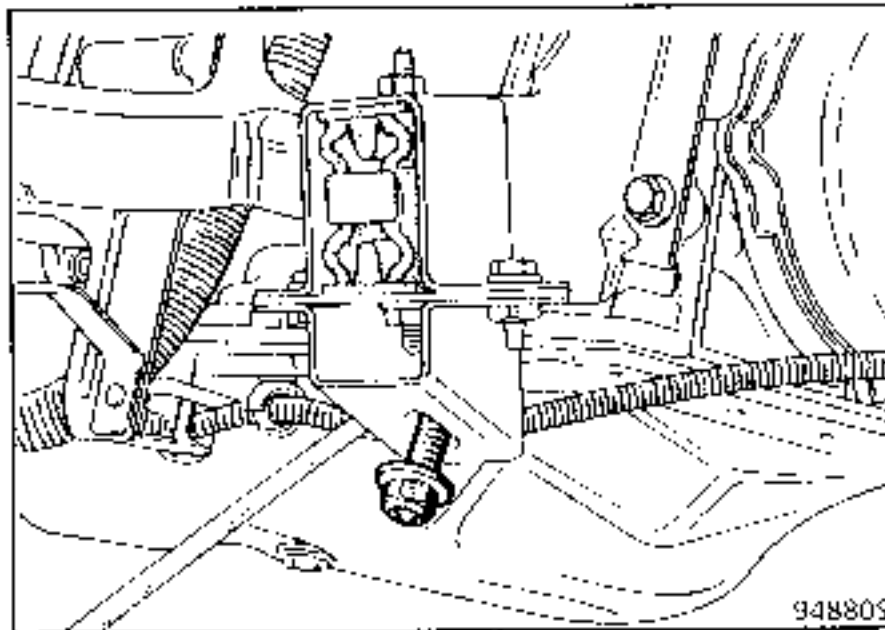

Remove the mounting nut for the front engine mounting pad.

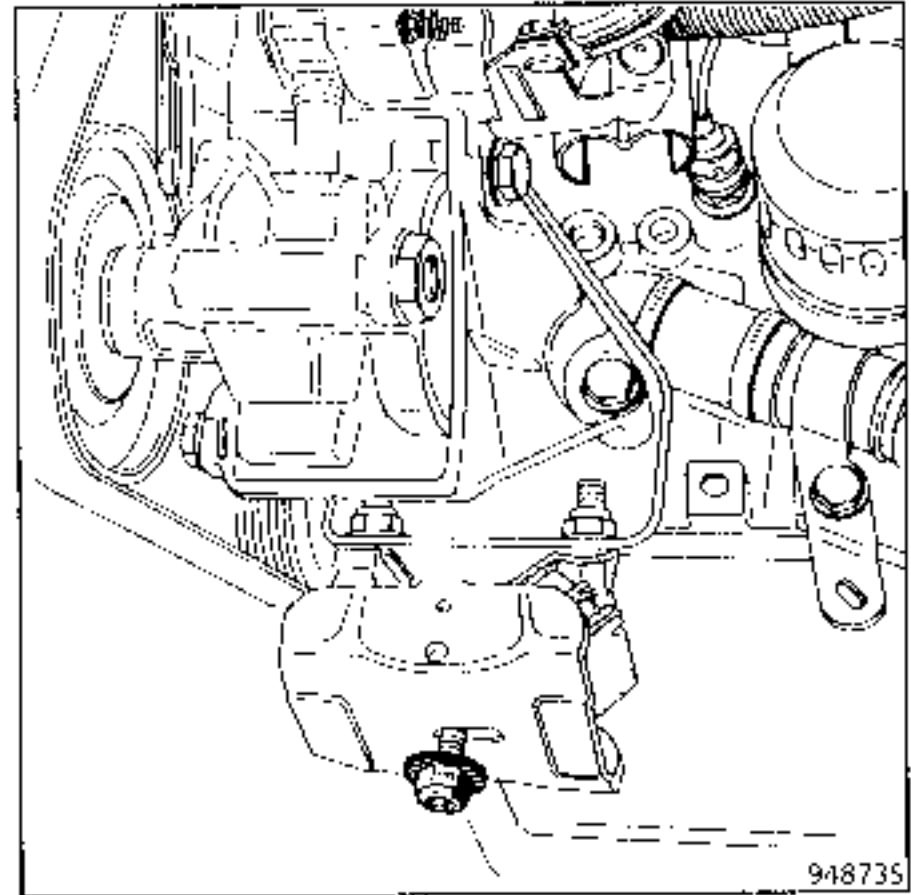

Remove:

- the battery,
- the air filter,
- the air filter mounting after disconnecting the relays,

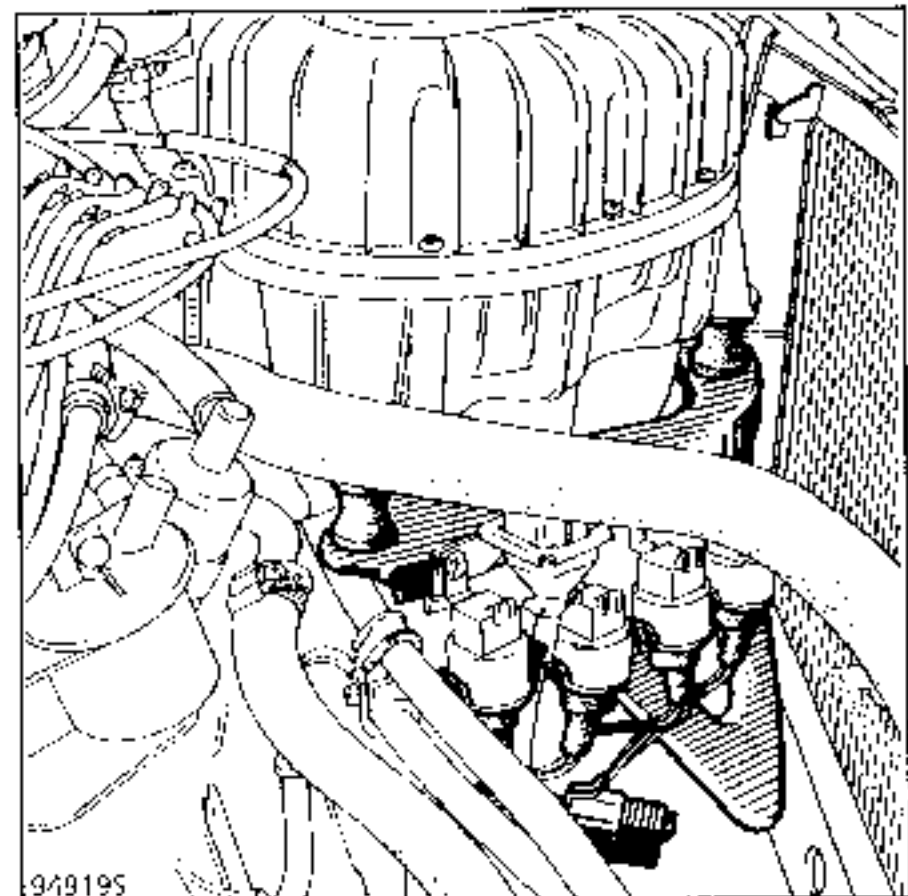

- the automatic transmission computer.

Remove the battery mounting.

Remove the expansion bottle and the power assisted steering reservoir.

Remove the **AEI** unit and the mounting bolts (11) for the expansion bottle mounting.

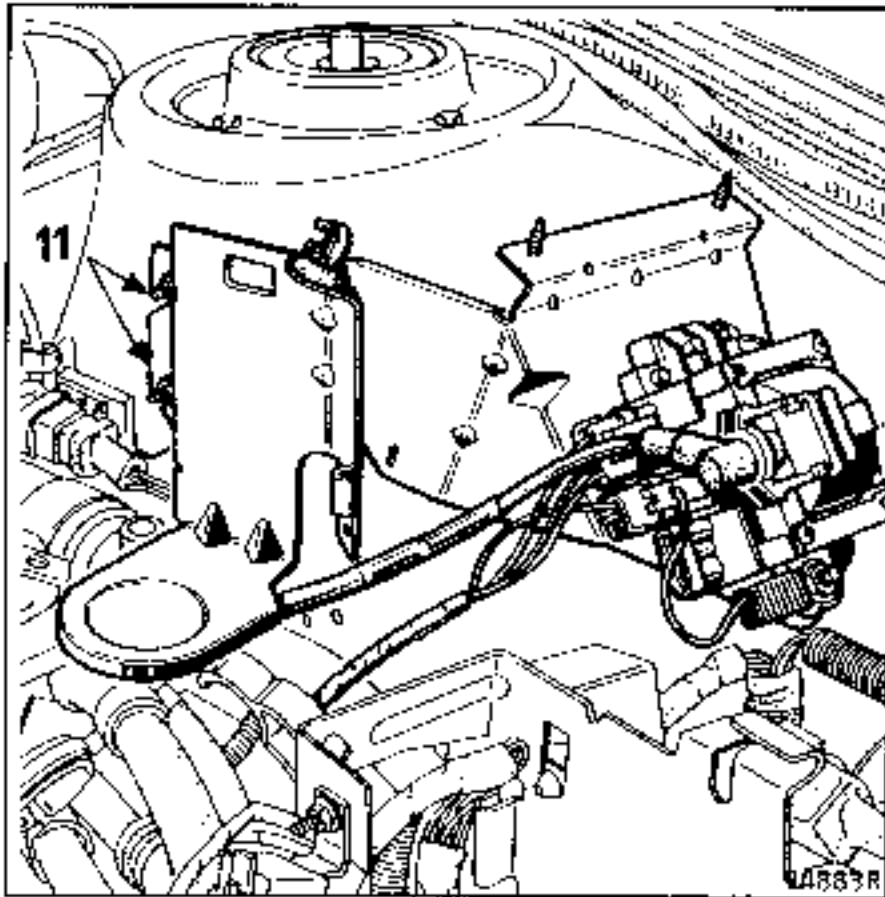

On the right hand side of the vehicle

Remove:

- the accelerator cable,
- the fuel pipes from the flowmeter.

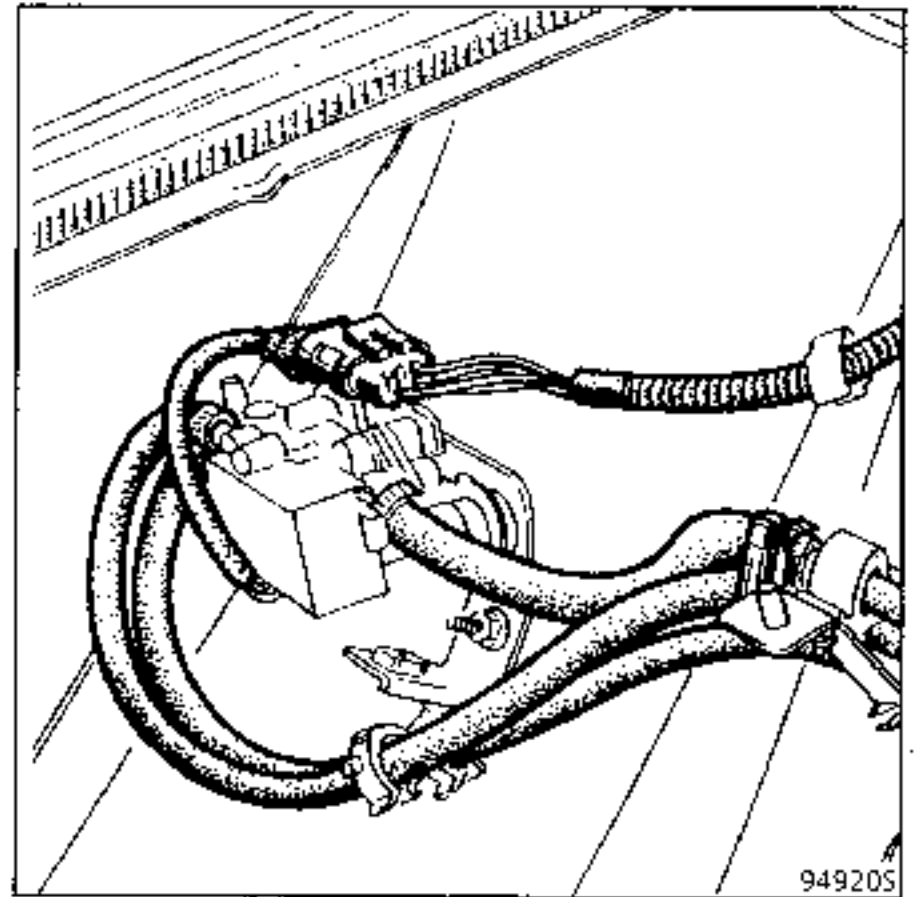

Disconnect the connector for the fan assembly wiring (1) and the oil level sensor connector (2).

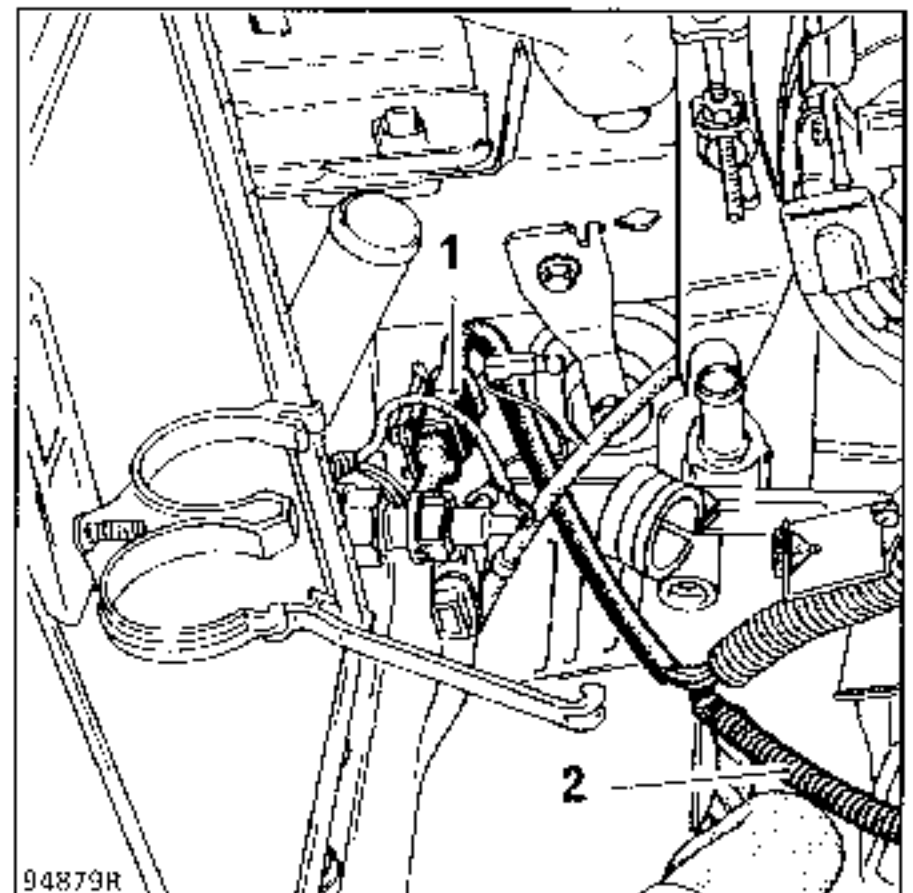

On the left hand side of the vehicle

Disconnect the wiring.

Remove the pipes for the solenoid valves.

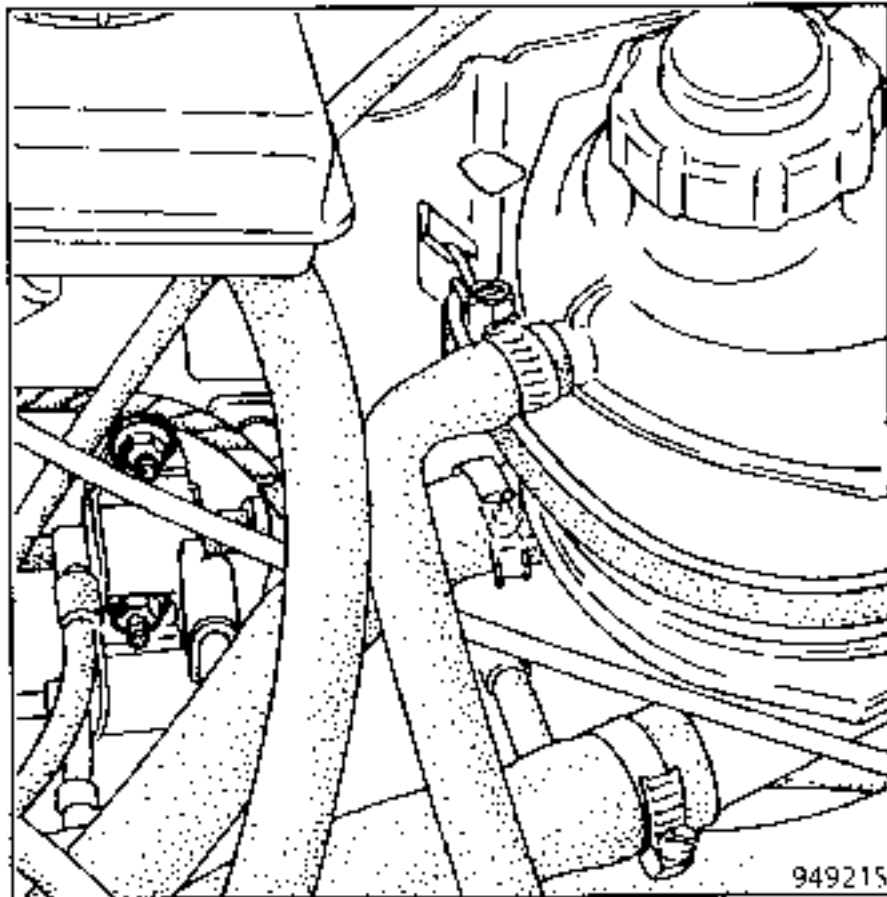

Drain the cooling circuit by disconnecting the upper and lower radiator hoses.

Remove the heating hoses.

Remove the brake servo vacuum pipe.

Remove:

- the A.T. control cable.
- the speedo cable (1) after unscrewing it from the automatic transmission.

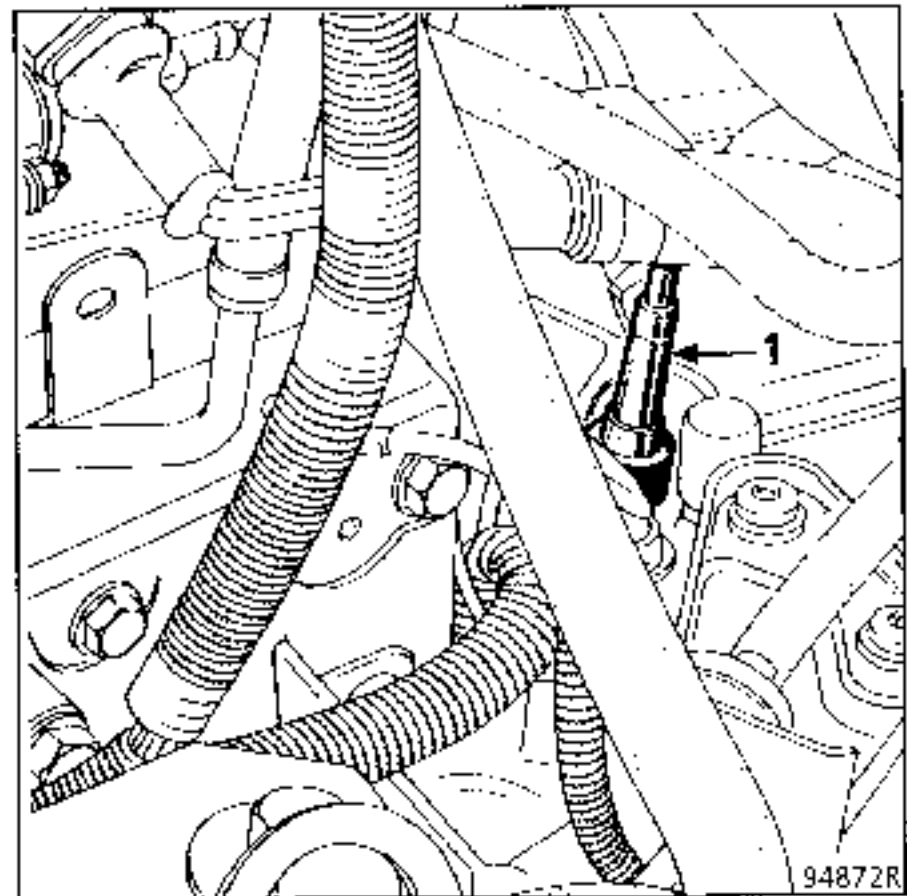

Remove the fuel pipes.

Remove the connector (2) for the kickdown switch.

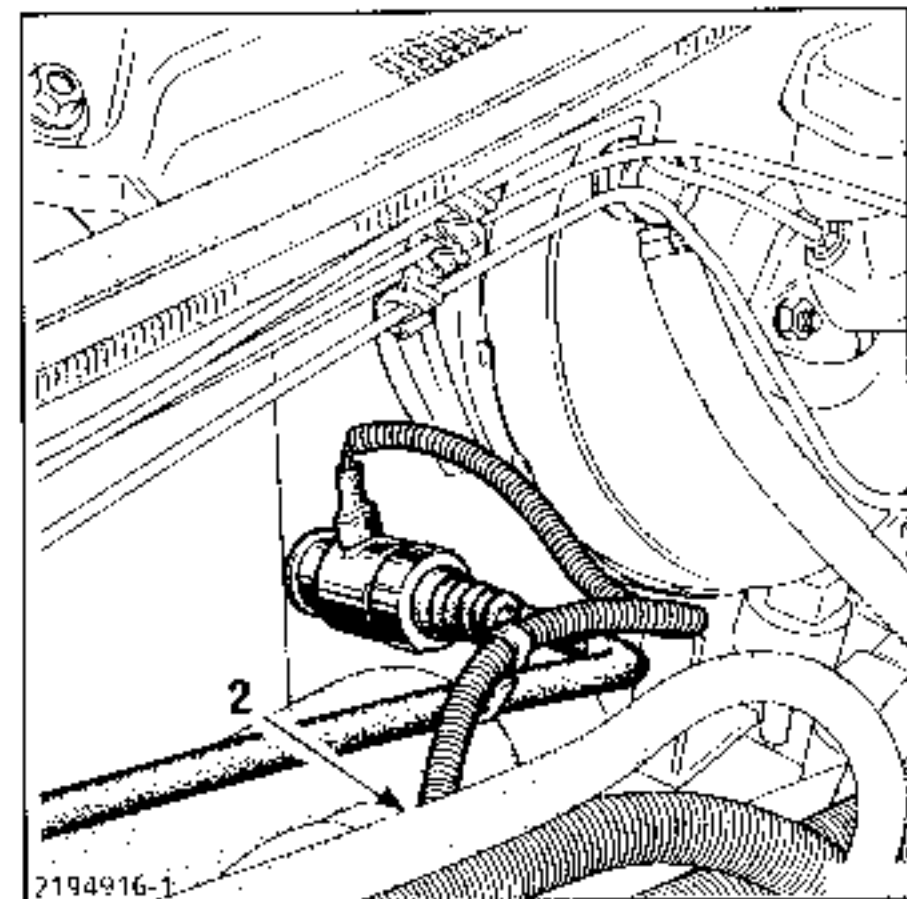

Remove the power assisted steering pipes.

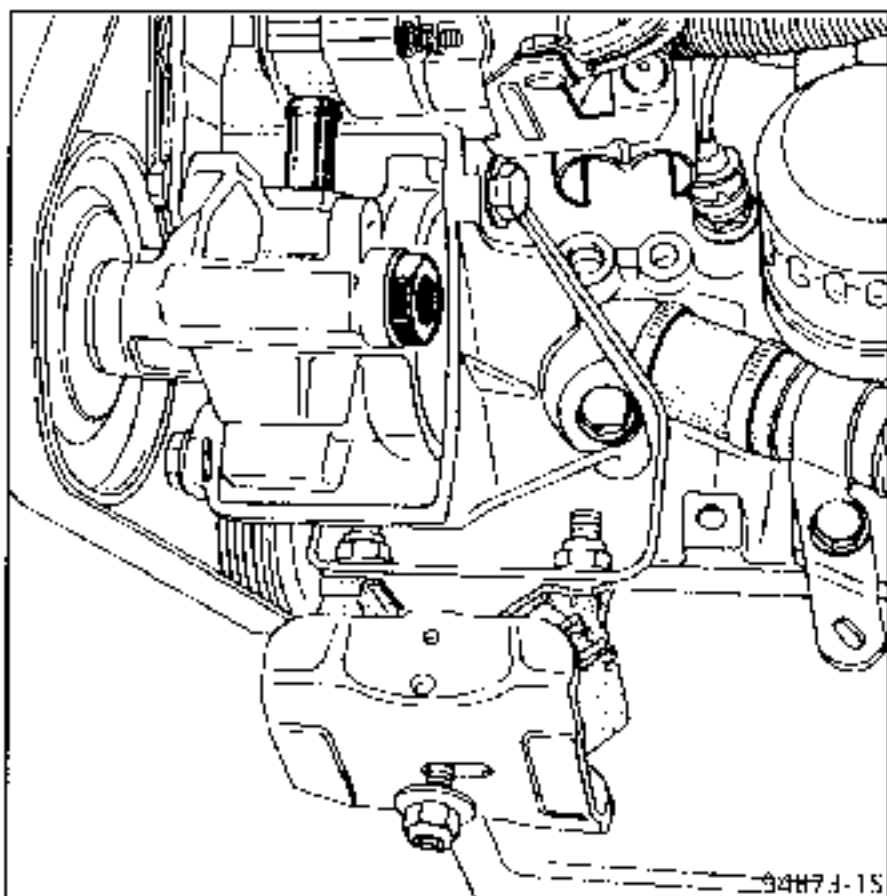

Fit the load positioning tool (eg- NAUDER 1805), and tension the lifting chains.

Take the weight of the engine and automatic transmission assembly.

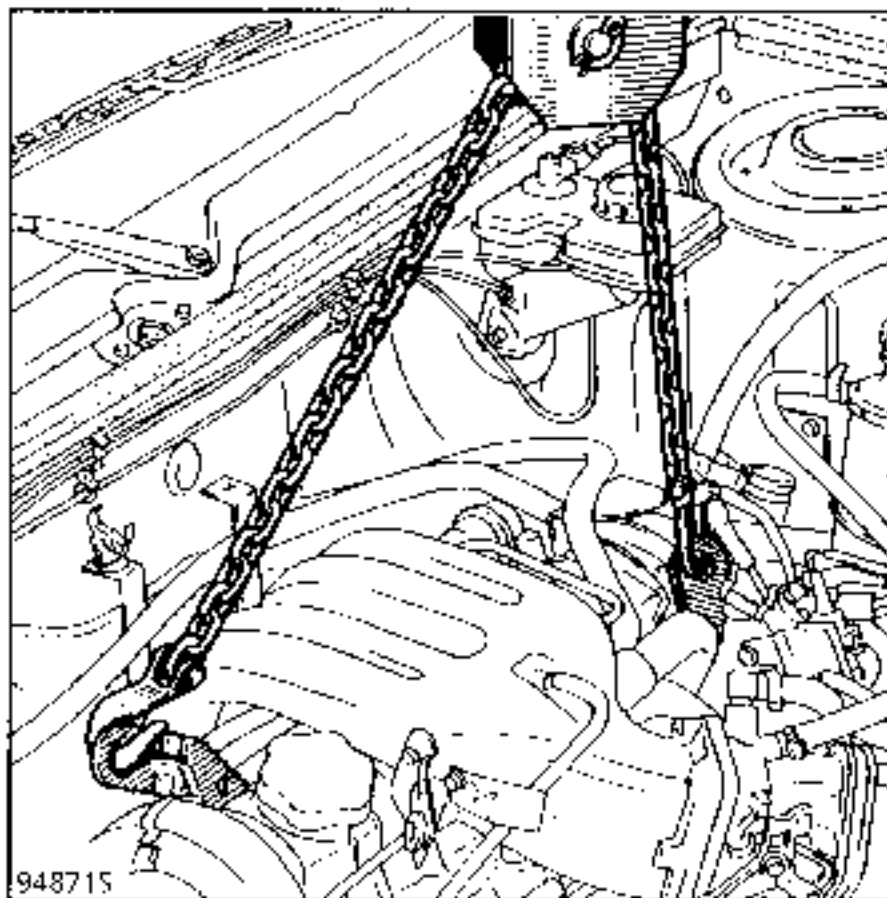

Remove the rear mounting bolt.

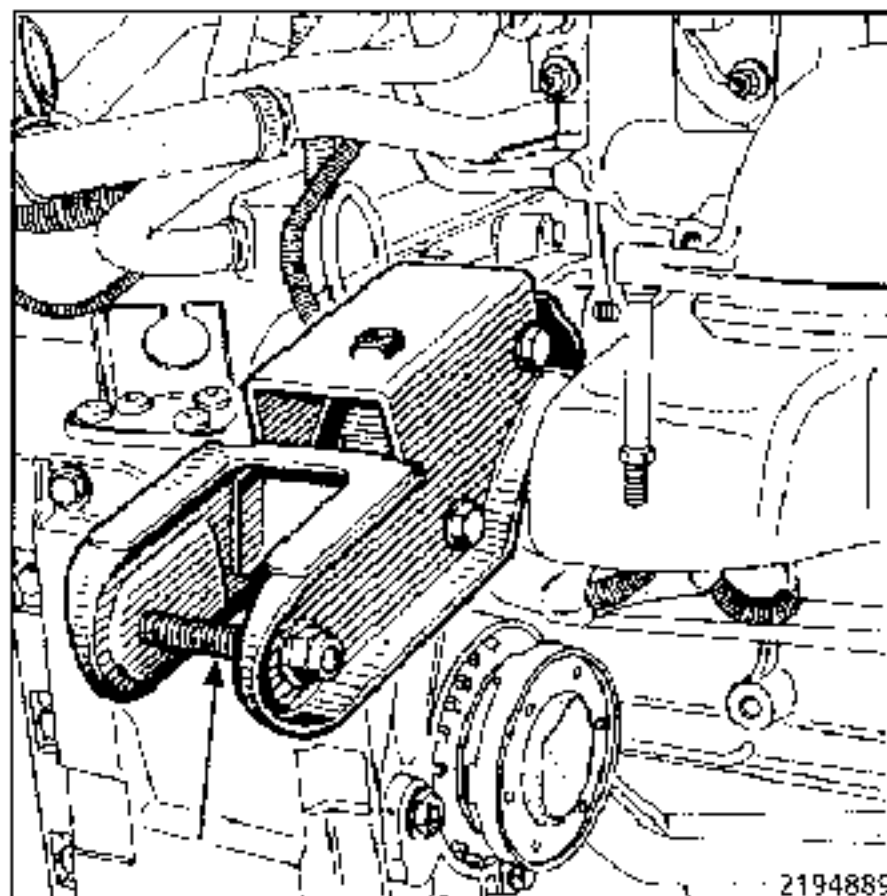

Remove the automatic transmission mounting pad.

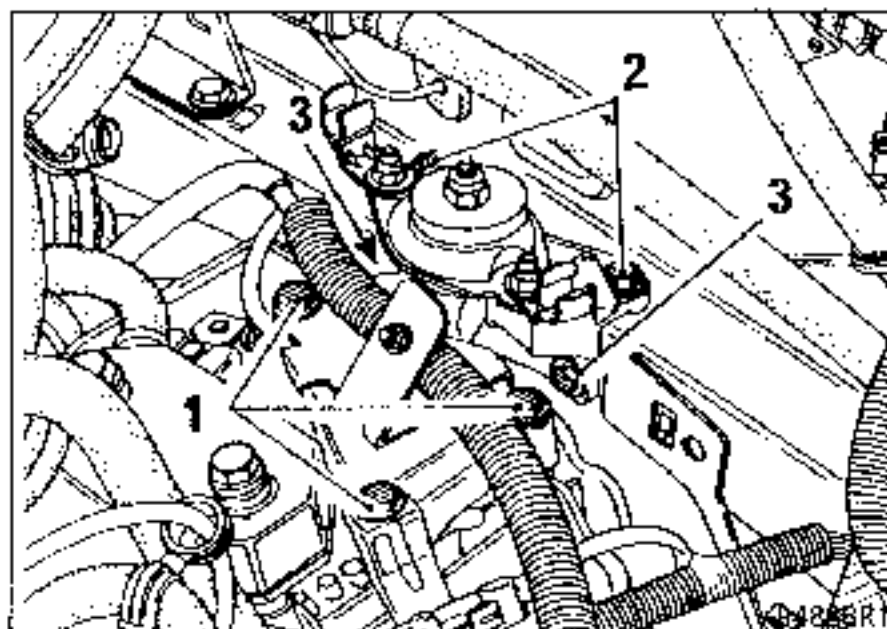

Remove the engine and automatic transmission assembly.

Remove:

- the converter protective plate.

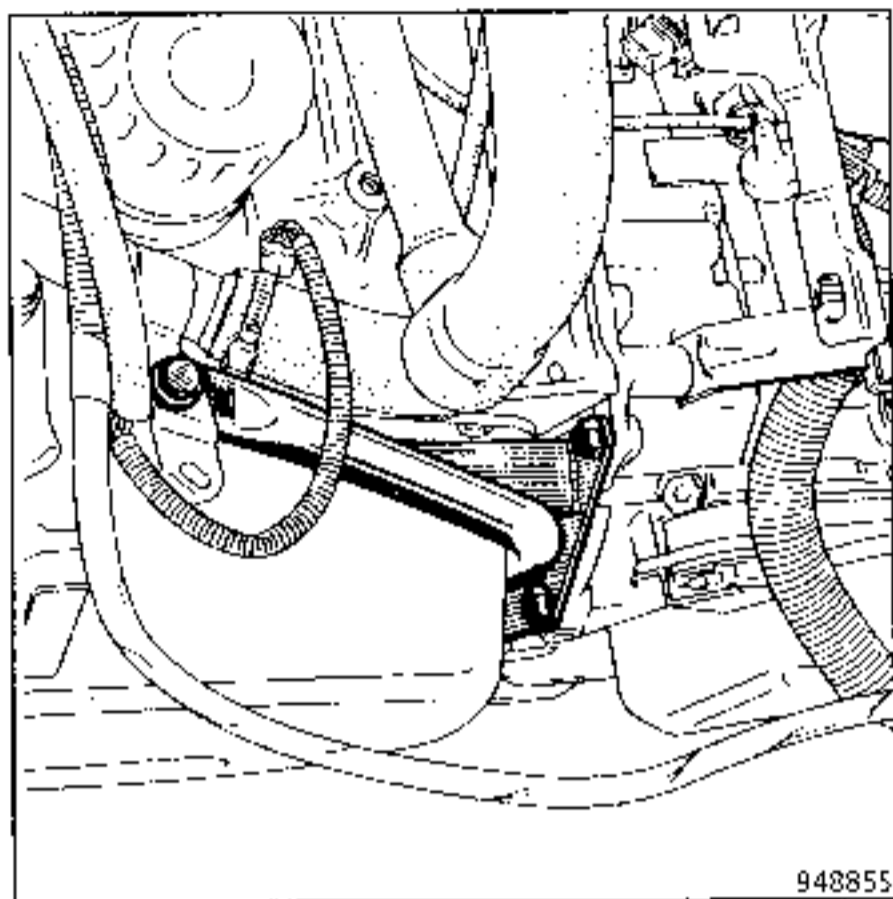

Fit the locking tool **Mot. 582** and remove the three nuts mounting the drive plate to the converter.

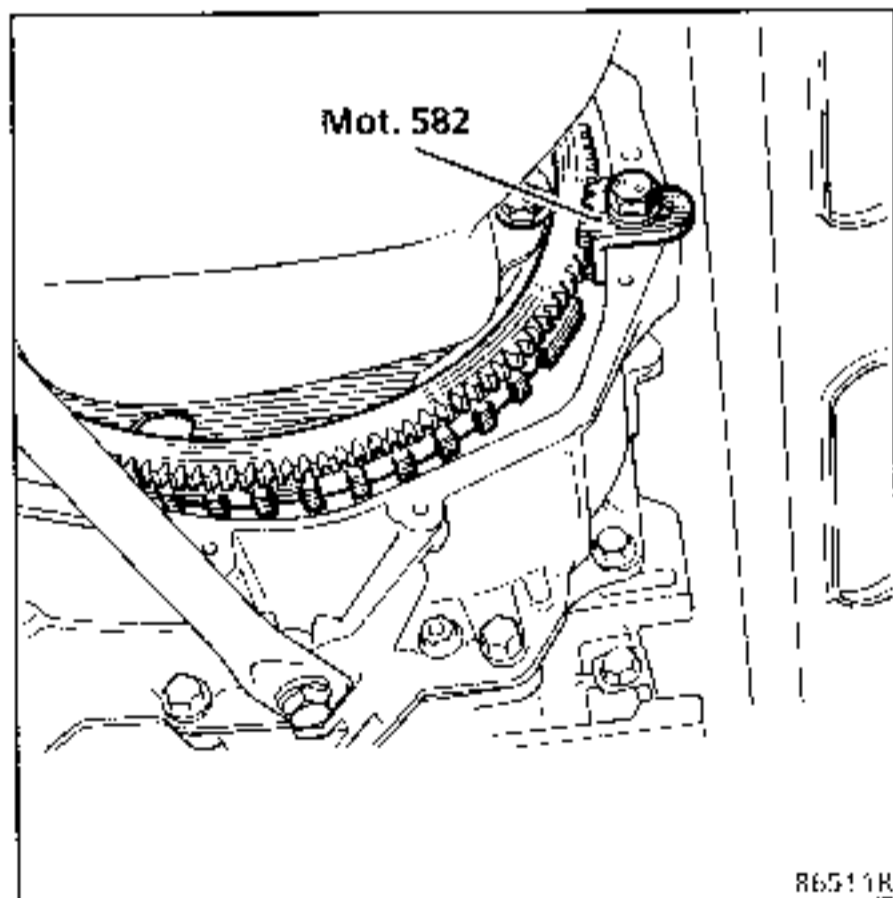

Remove:

- the starter motor,
- the oil cooler.

Release the wiring.

Remove the bolts mounting the automatic transmission to the engine.

Release the transmission from the engine taking care not to let the converter fall out.

REFITTING

Before refitting the automatic transmission to the vehicle, check the centring dowels are present on the engine block.

Lubricate the device centring the converter on the crankshaft using **MOLYKOTE BR2**.

Fit the automatic transmission to the engine and tighten the nuts and bolts to a torque of **4 daN.m**.

Fit the drive plate nuts on the converter using **LOCTITE FRENBLOC** and tighten them to a torque of **1.5 daN.m**.

Refit:

- the oil cooler and tighten the bolts to a torque of **2.5 daN.m**,
- the starter motor,
- the converter protective plate.

Refit the engine and automatic transmission assembly back into the engine compartment.

Refitting is then the reverse of removal.

Special notes:

Before repositioning the driveshafts, fill the sun-wheel output flanges with **MOLYKOTE BR2** grease.

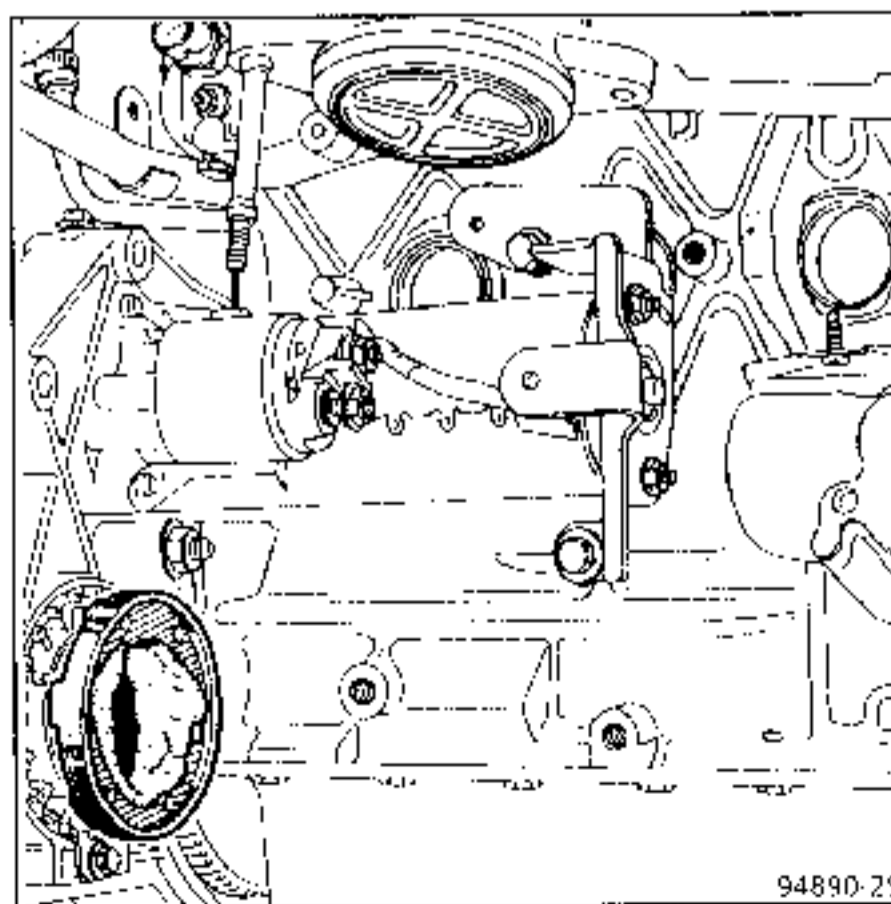

IMPORTANT : when refitting the accelerator cable, ensure the adjustment is correct as this affects the operation of the kickdown switch.

Refit the exhaust downpipe with a new gasket at the catalytic converter end and the sealing clip at the manifold end.

To ensure the exhaust pipe is correctly aligned, tighten the mountings at the manifold first and finish at the catalytic converter.

Carry out the following operations:

- fill and bleed the cooling circuit (**sub-section 19**),
- top up the level of the power assisted steering fluid,
- top up the level of the automatic transmission.

VERY IMPORTANT

REMEMBER TO VALIDATE FULL LOAD

to reprogramme the load potentiometer travel into the automatic transmission computer.

Connect the **XR25** to the vehicle's diagnostic socket.

The socket is located on the battery mounting next to the injection computer.

Set the ISO selector on position **S4**.

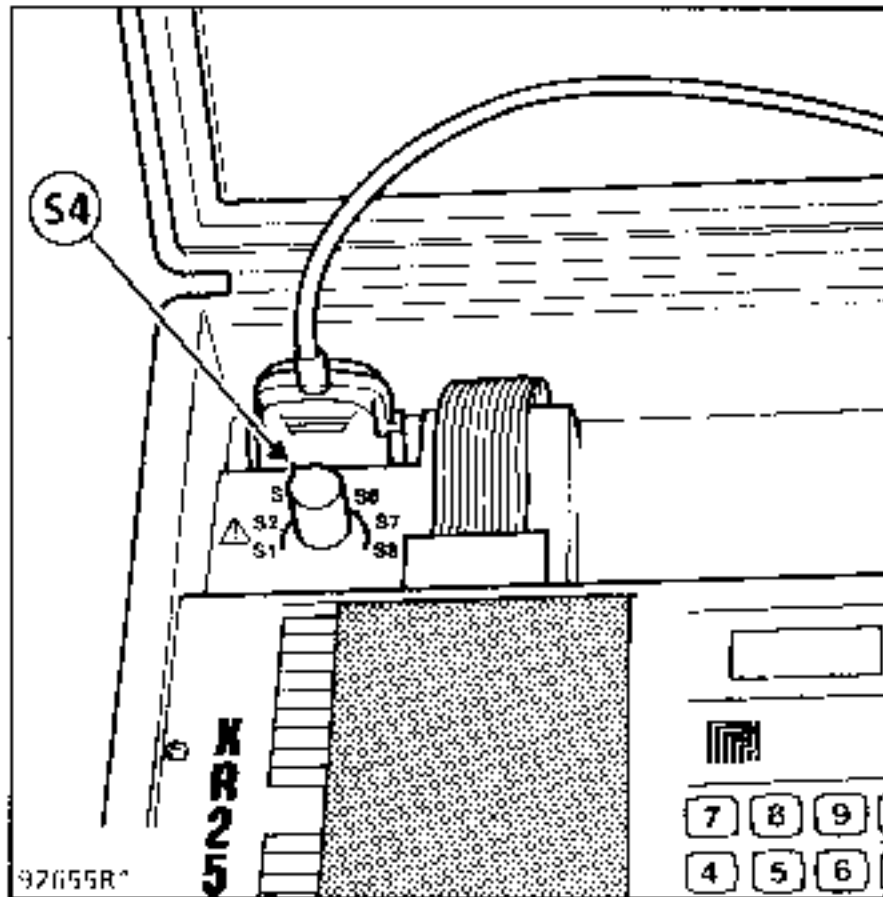

Turn the ignition on but do not start the engine.

Enter the code for transmission

"A" :

D	0	4
---	---	---

The bargraph display should only show the following bargraphs illuminated 1-3-4-5-6-11 either on the right or on the left hand side.

Validate full load by pressing the accelerator pedal for **5 seconds**:

- bargraph 2 illuminates,
bargraph 6 extinguishes.

Only bargraphs 1-3-4-5-11 should be illuminated when the accelerator pedal is released.

Turn the ignition on again and enter the code for transmission "A" to check the validation was carried out correctly.

Repeat the operation if necessary.

Turn the ignition off and disconnect the **XR25**.

IMPORTANT: if the full load value is incorrectly validated this may cause:

- permanent illumination of the warning light,
- faults when changing gear,
- incorrect gear change thresholds,
- difficulty in using the kickdown function,
- driving discomfort.

VERY IMPORTANT : TURN THE IGNITION OFF.

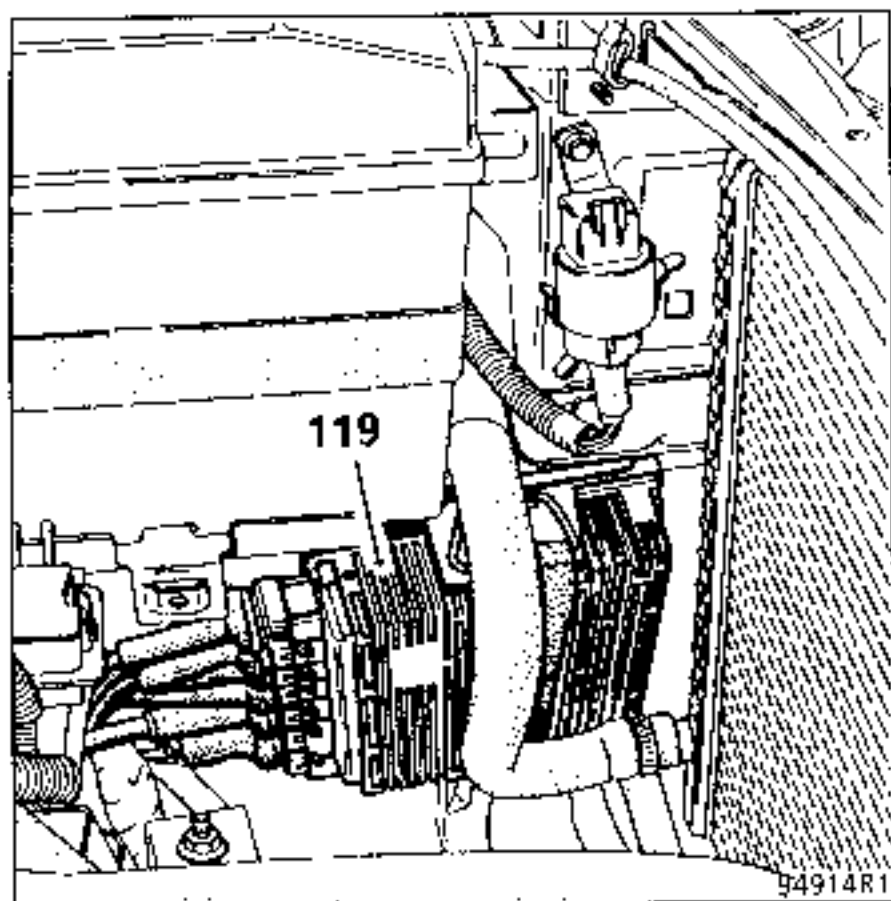

When replacing the computer or erasing the memory, remember to validate "full load".

Line pressure sensor (8)

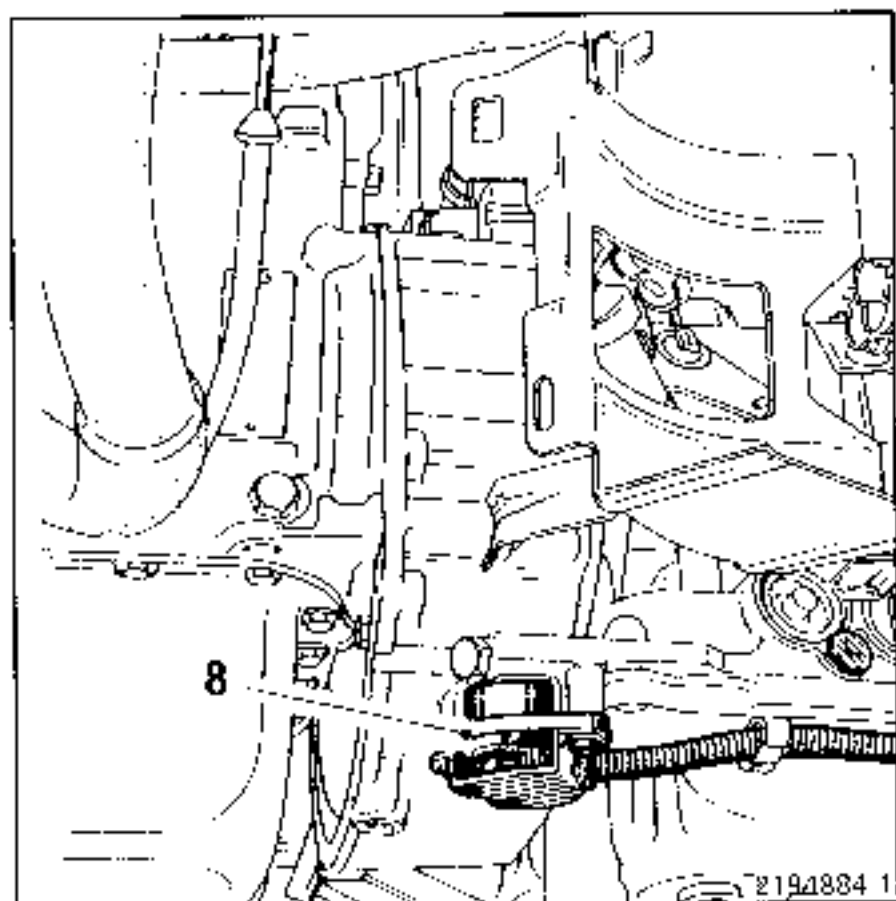

The line pressure sensor is mounted by two bolts on the automatic transmission housing.

It can be reached directly from under the vehicle, after releasing the protective sleeve.

AFTER REPLACING THIS COMPONENT, REMEMBER TO ERASE THE MEMORY AND VALIDATE "FULL LOAD".

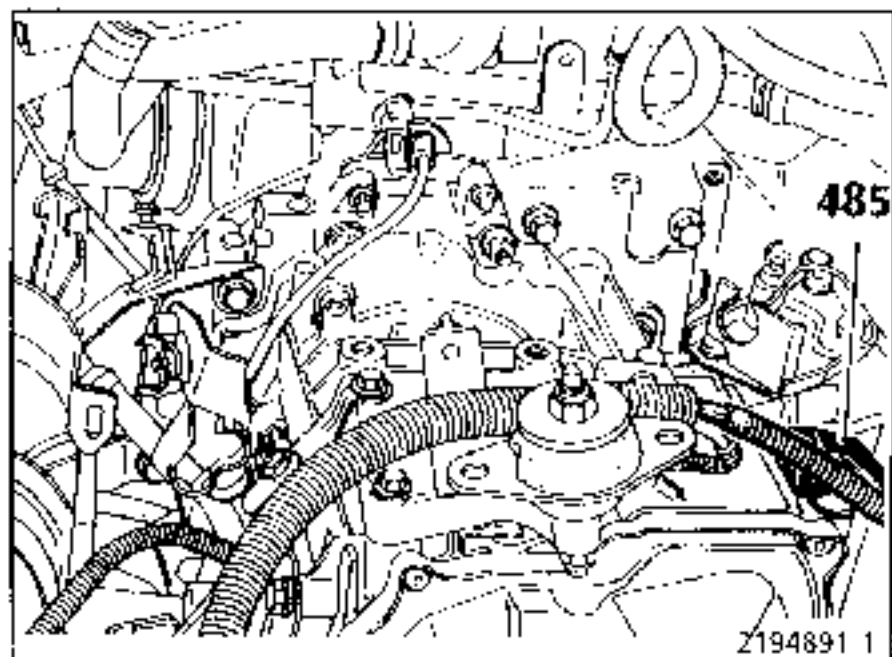

The switch is mounted on the automatic transmission housing.

It may be reached from above or below the vehicle, after removing the mounting bracket and the earth bolt.

AFTER REPLACING THIS COMPONENT, REMEMBER TO ERASE THE MEMORY AND VALIDATE "FULL LOAD".

Speed sensor (250)

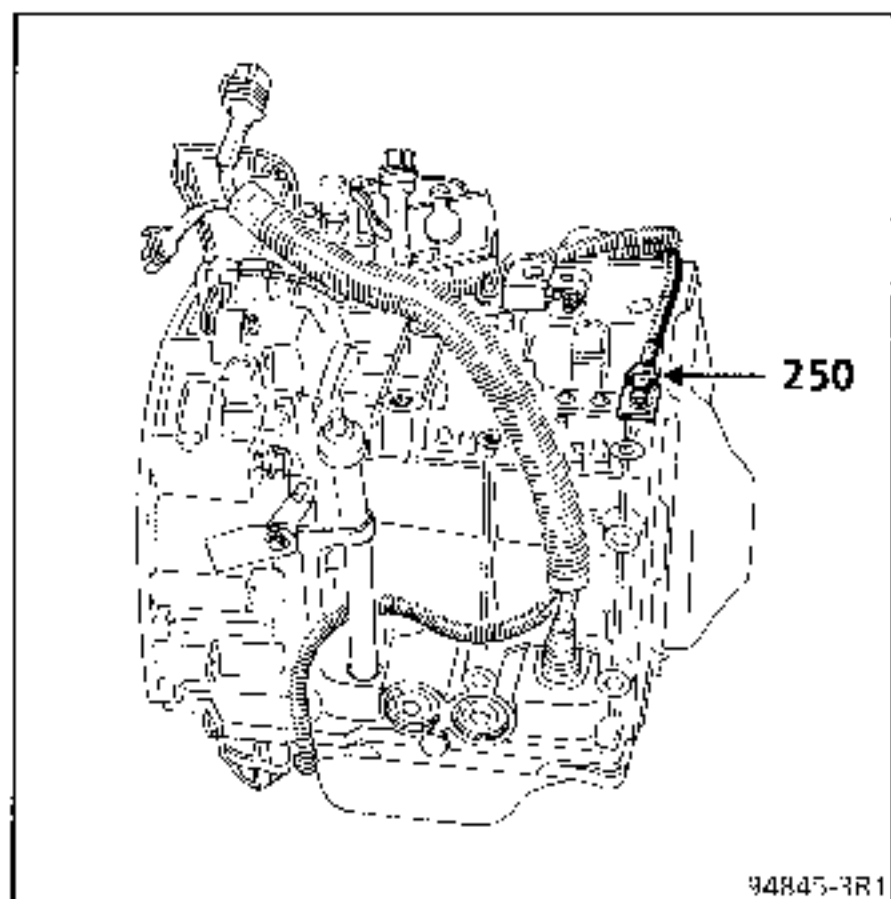

The speed sensor is mounted on the top of the automatic transmission.

It may be reached after removing:

- the expansion bottle,
- the power assisted steering reservoir.

Release the wiring.

Remove the mounting pad.

AFTER REPLACING THIS COMPONENT, REMEMBER TO ERASE THE MEMORY AND VALIDATE "FULL LOAD".

TIGHTENING TORQUES (in daN.m) 	
Solenoid valve mounting bolt	0.9
Distributor plate mounting bolt	0.5
Hydraulic distributor mounting bolt	0.5

The hydraulic distributor must be removed to replace the sequence and modulating solenoid valves and the temperature sensor.

Remove bolts (A) mounting the distributor cover plate (B).

Remove the mounting bolts for the sequence (C) and modulating (D) solenoid valves.

Release the solenoid valves - sensor assembly from the distributor.

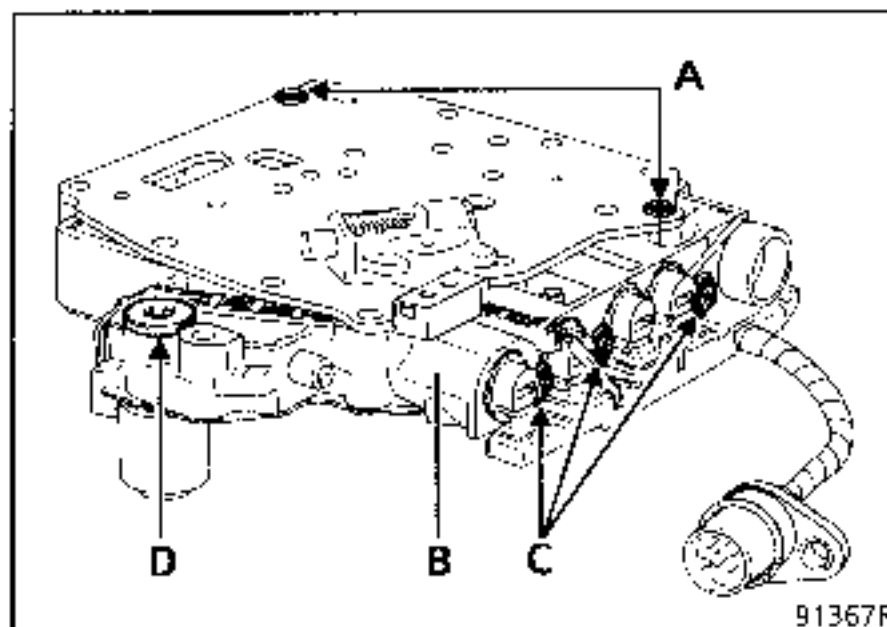

There are no special difficulties in replacing the assembly - refitting is the reverse of removal.

VERY IMPORTANT : THE BOLTS MUST BE TIGHTENED TO THE RECOMMENDED TORQUE.

NOTE : each sequence solenoid valve has its own mounting - do not refit them incorrectly.

The reduction of engine torque during changing gear aims to:

- improve the smoothness of changing gear,
- reduce the theoretical load on the hydraulic components used during the gear change,
- reduce stress on the mechanical components.

Torque reduction is achieved by altering the advance point.

The torque reduction signal is provided by the A.T. computer to the injection computer: during the complete period of changing gear, the advance point is retarded by 35°.

Checking the connection between the A.T.computer and the injection computer

Condition	Selection on XR25	Display on XR25	Note
ECO warning light extinguished, lever in 3rd gear hold, vehicle at ≈ 37 mph (60 km/h) - A.T. in 2nd Change from 2/3 with no load	Enter D 03 # 51	0000	The XR25 display will briefly show zero

KICKDOWN FUNCTION

For the operation of the kickdown function on automatic transmissions of type **AD4**, two items of information are required:

- **1st item of information :**
Full load at accelerator pedal to give load potentiometer information (less than 6 %, value read on XR25 using # 12).
- **2nd item of information :**
Detection by the kickdown switch located on the accelerator cable that the excess accelerator pedal travel has been used. The switch is compressed and establishes an earth connection to the computer.

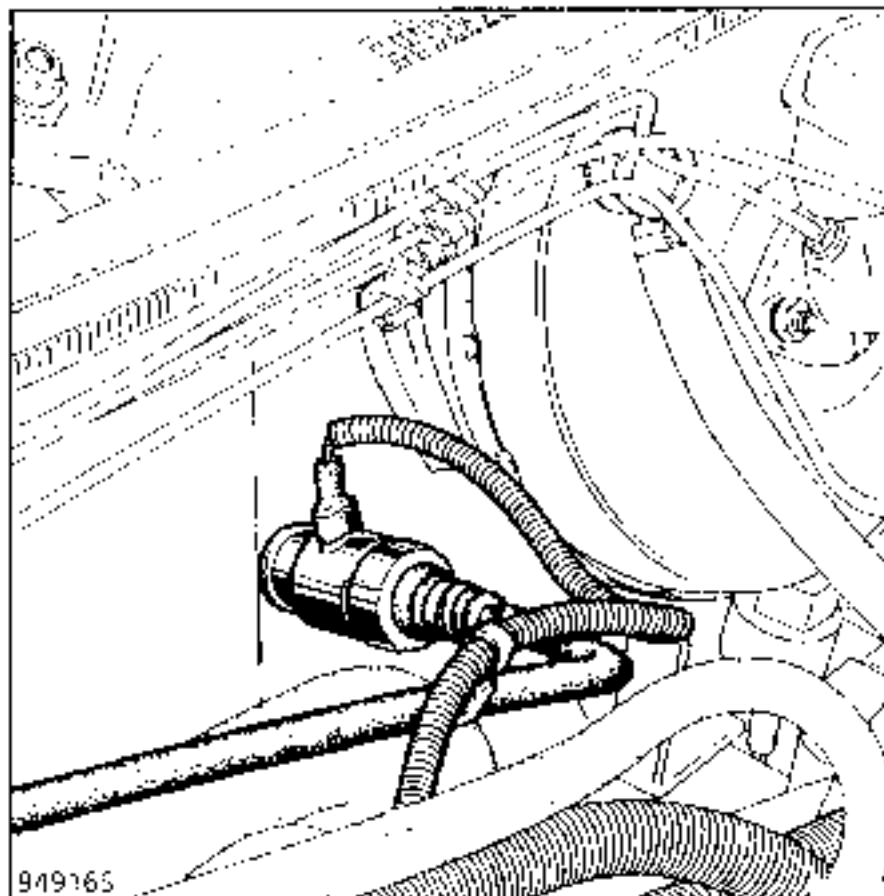

This method allows the kickdown switch to be used at higher engine speeds.

To ensure the accelerator pedal excess travel is used, ensure the cable is correctly adjusted (see following page).

ADJUSTING THE CABLE

Connect the XR25 to the vehicle's diagnostic socket.

Set the ISO selector to position **S4**.

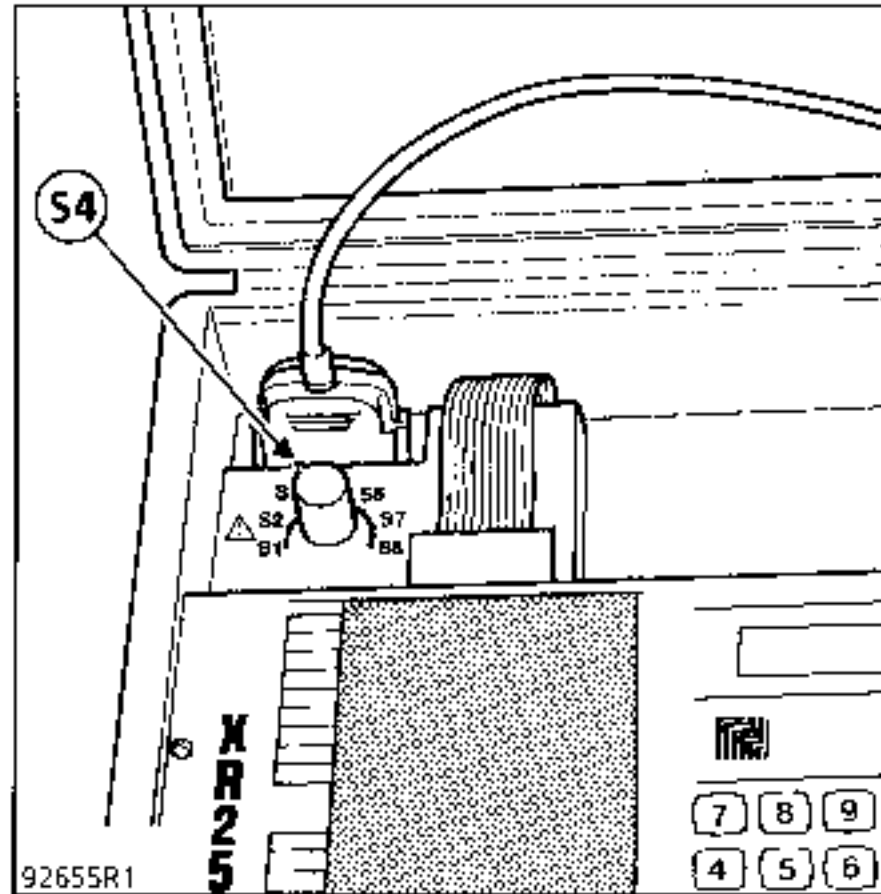

Turn the ignition on but do not start the engine.

Enter the code for transmission "A" D 04 and enter # 22.

Test conditions	Display on XR25	Notes
Accelerator pedal not depressed - no load (PL)		If the value 1 is not shown, check the electrical connection on the kickdown switch.
Accelerator pedal depressed - full load (PF)	□	If the value 0 is not shown for PF, check the adjustment of the accelerator cable.

KEY

8	Line pressure sensor
103	Alternator
104	Ignition switch
119	Computer
129	Gear change threshold control
160	Stop switch
163	Starter motor
172	Rear right hand light
173	Rear left hand light
182	Right hand reversing light
222	Throttle potentiometer
225	Diagnostic socket
232	Starting relay
247	Instrument panel
250	Speed sensor
260	Fuse box
443	Solenoid valve
485	Multifunction switch
569	Kickdown switch
602	Reversing lights relay

Connections

R1	Dashboard/ rear right
R2	Dashboard/ rear left
R5	Dashboard/ heating casing
R6	Dashboard/ centre console
R11	Dashboard/ left hand side member
R17	Heating casing/ engine
R28	Engine / left hand side member

Earths

M9	Front right hand pillar earth
----	-------------------------------

CONNECTION BETWEEN COMPUTER / ELECTRICAL COMPONENTS ON AUTOMATIC TRANSMISSION

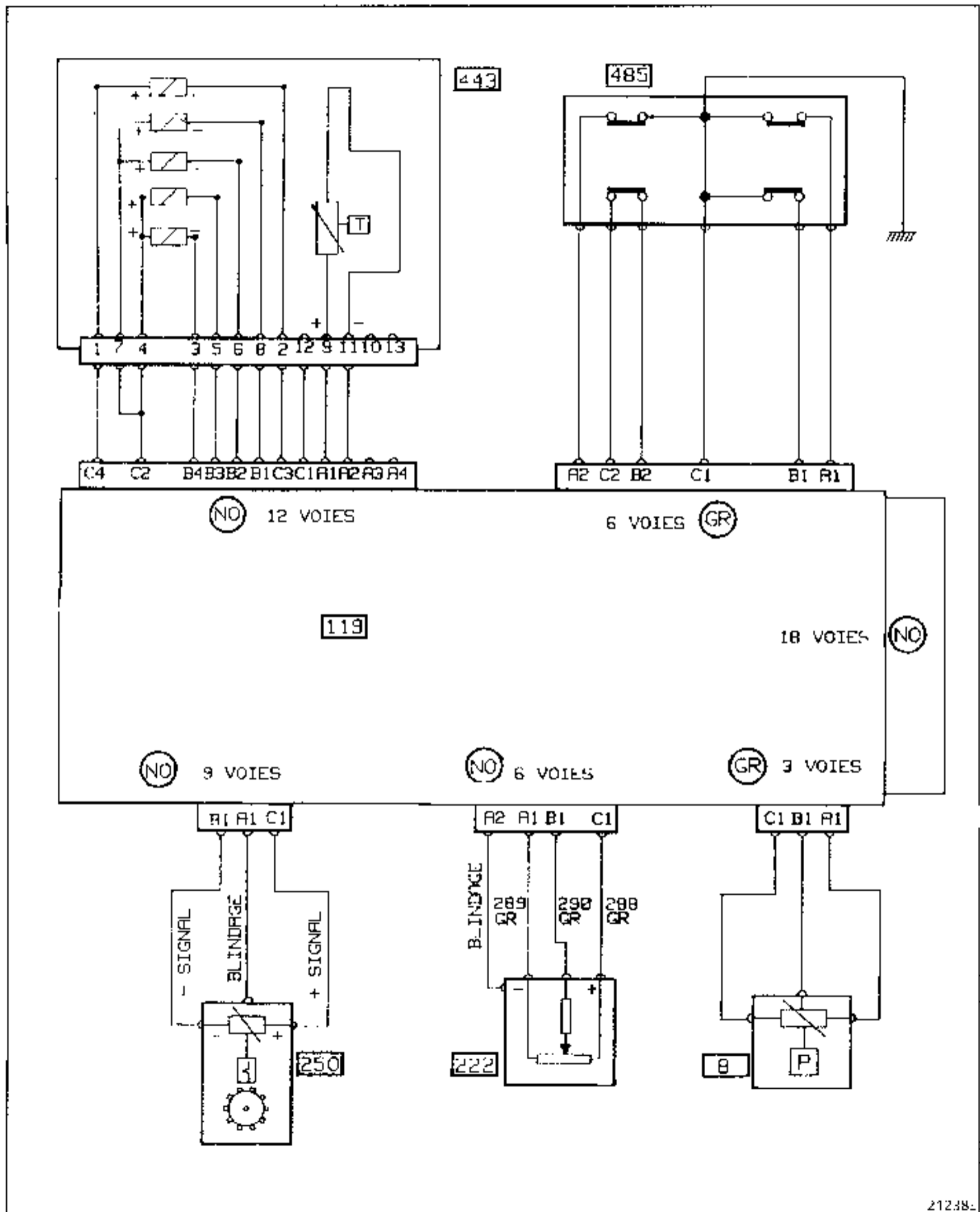

21238-

Since the driveshafts are of different lengths and have different specifications depending on the type of gearbox, they must be correctly matched (refer to the parts catalogue for the vehicle concerned).

The identification plates on the gearbox and driveshafts show coloured markers which allow them to be matched according to the tables below.

The driveshafts are marked by an adhesive label near the wheel end gaiter.

1st assembly

Adhesive label with two coloured bands.

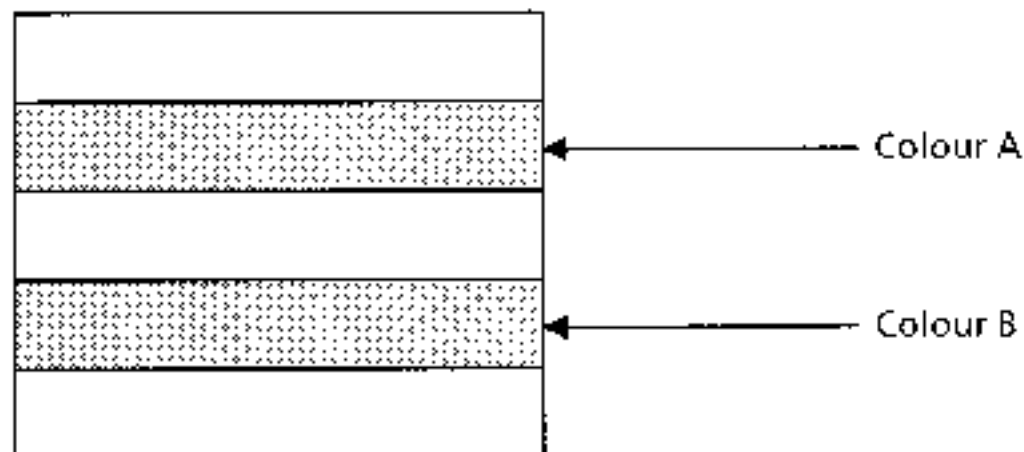

Gearbox	Wheel end joint	Colour marking on gearbox identification plate	Driveshaft colour markings			
			LEFT		RIGHT	
			A	B	A	B
JB 2/3	GE 86	Black	White	Red	White	Red

2nd assembly

Adhesive label with five coloured bands.

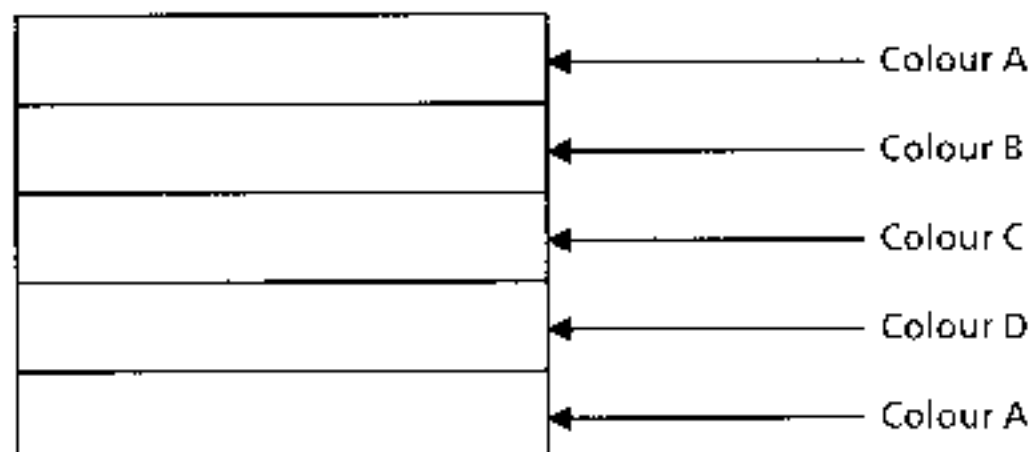

Gearbox	Wheel end joint	Colour marking on gearbox identification plate	Driveshaft colour markings									
			LEFT					RIGHT				
			A	B	C	D	A	A	B	C	D	A
JB 1	GE 76	Black	White	Black	White	White	White	Black	White			
JB 2	GE 86											
JB 3												

REPLACEMENT

SPECIAL TOOLING REQUIRED		
B.Vi.	31-01	Roll pin punch
Rou.	604-01	Hub locking tool
T.Av.	476	Ball joint extractor
T.Av.	1050-02	Driveshaft extractor

TIGHTENING TORQUES (in daN.m)		⚠
Driveshaft nut	25	
Bolt mounting gaiter to gearbox	2.5	
Wheel bolts	9	
Shock absorber base nut	11	
Brake caliper mounting bolt	10	
Track rod end nut	4	

REMOVAL

Remove:

- the brake assembly (suspend it from the chassis to avoid damaging the brake hose),
- the driveshaft nut using tool Rou. 604-01.

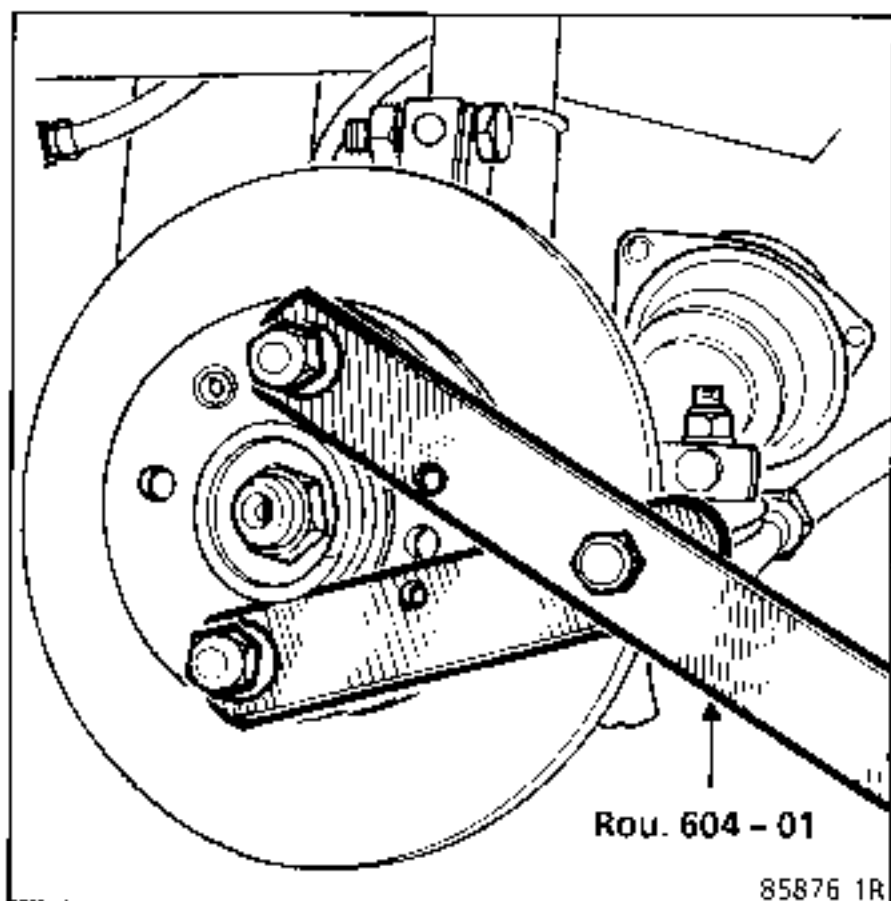

On the left hand side:

- Drain the gearbox.
- Remove the three bolts (1).

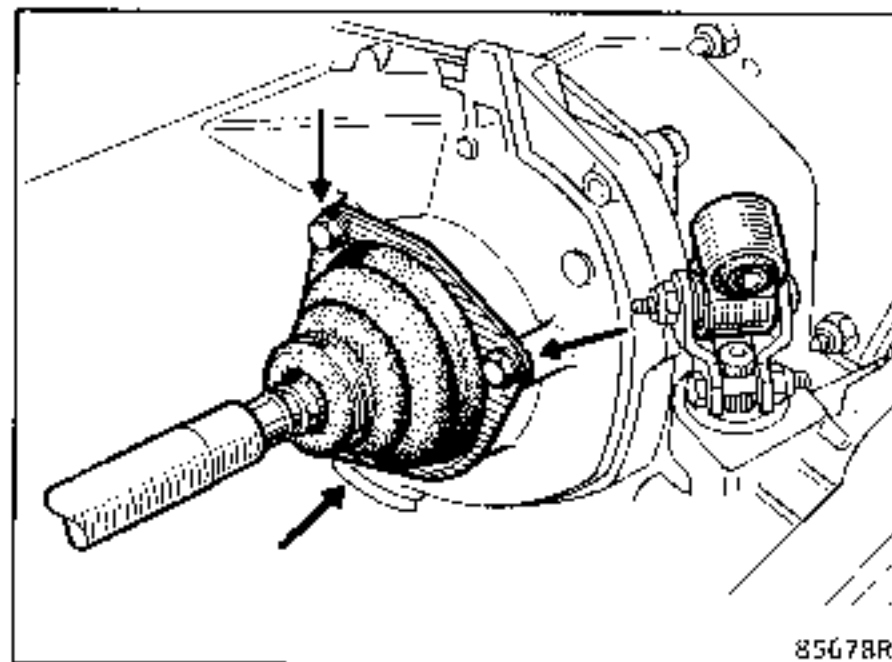

On the right hand side:

Remove the roll pin using tool B.Vi. 31-01.

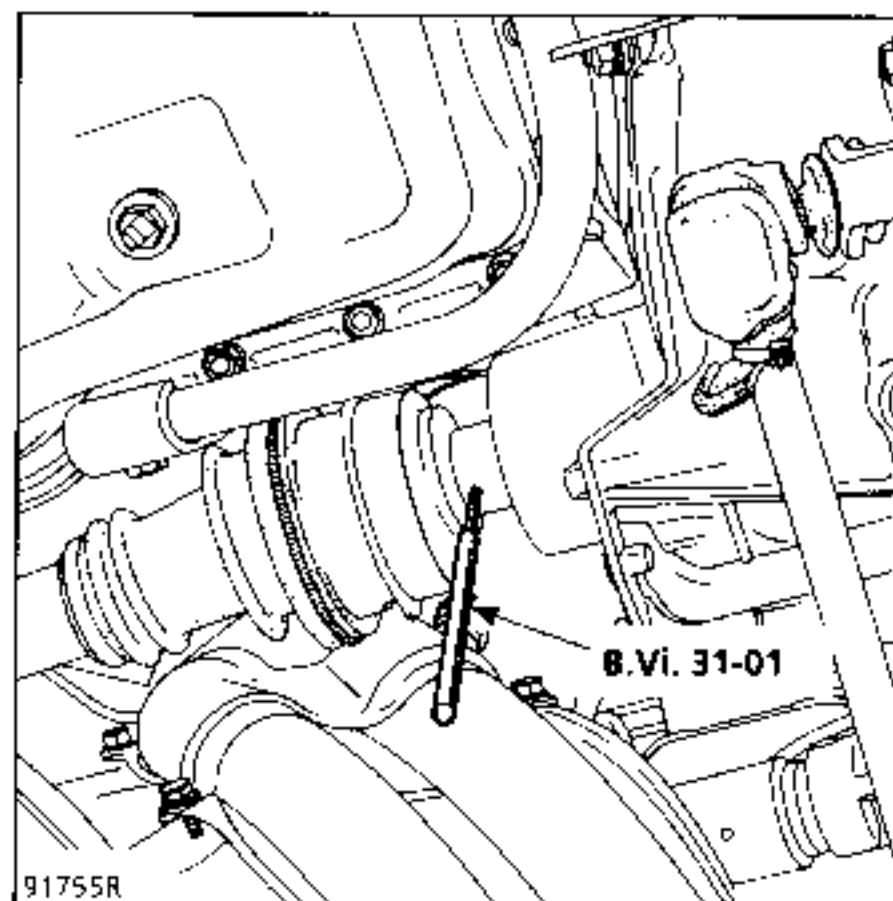

REPLACEMENT (cont)**On both sides:****Remove:**

- the track rod end nut using tool T.Av. 476,

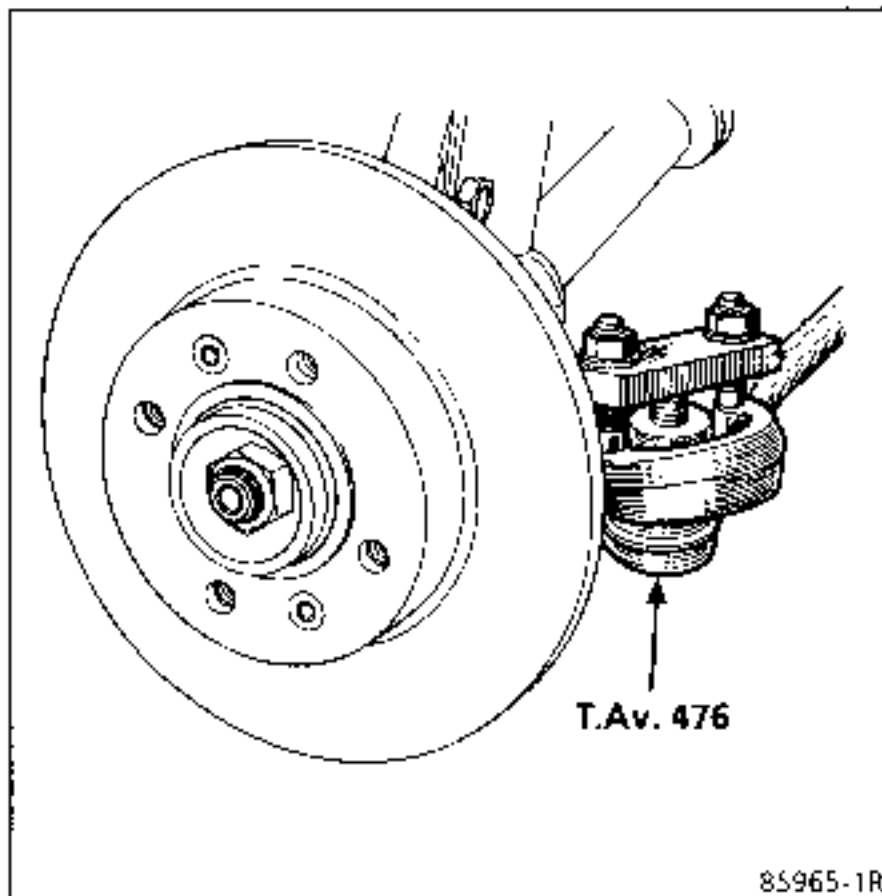

- the upper shock absorber base mounting bolt.

These vehicles are fitted with bonded driveshafts, which will need to be pushed back using tool T.Av. 1050-02.

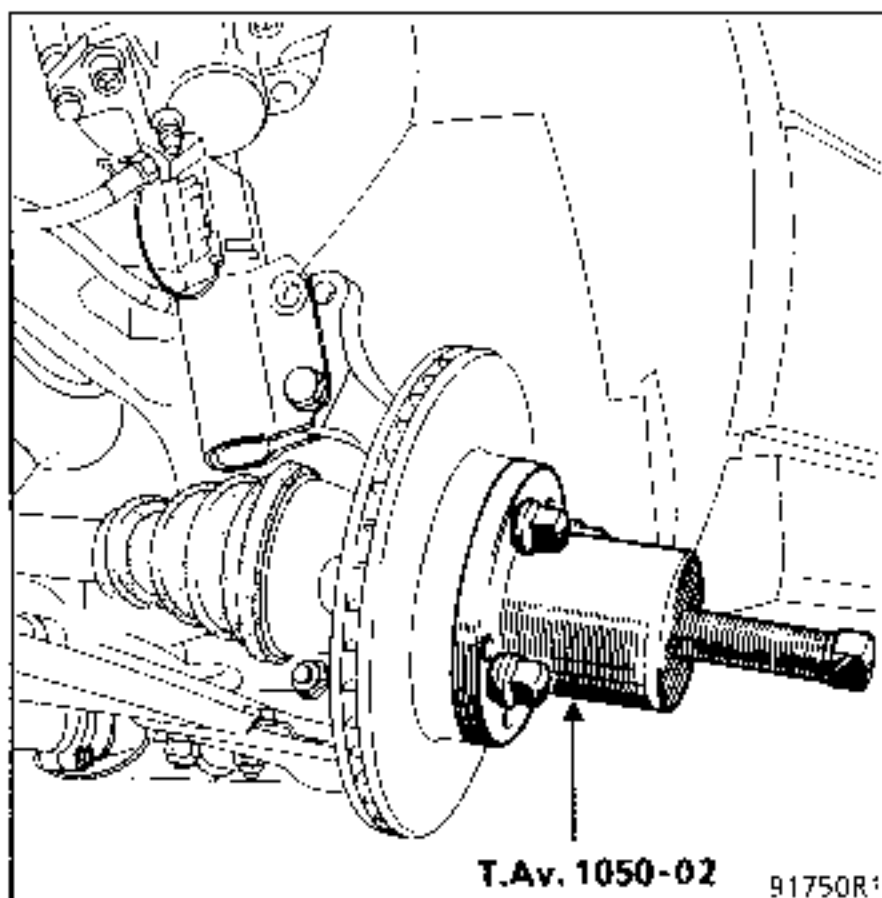

Remove the lower shock absorber base mounting bolt and remove the driveshaft.

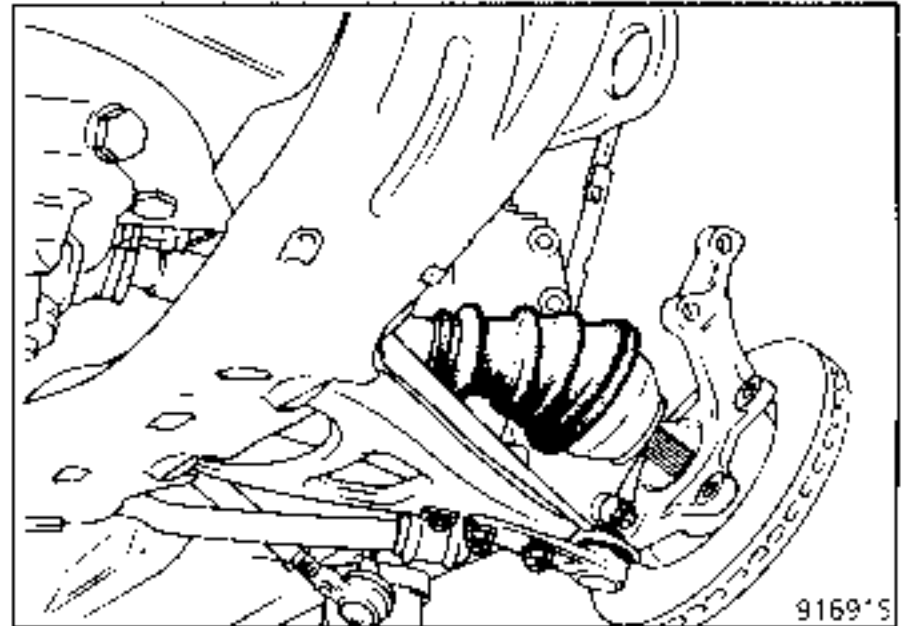

Take care not to damage the gaiters during this operation.

REFITTING

NOTE : the Parts Department now supplies driveshafts fitted with protectors and with fitting instructions. These instructions must be followed to ensure that the assembly is correct and of the highest QUALITY. Remember that the slightest knock on the gaiters causes the rubber to break and the driveshaft to be damaged in the long term.

REPLACEMENT (cont)

On both sides:

Coat the stub axle splines with **LOCTITE SCELBLOC**.

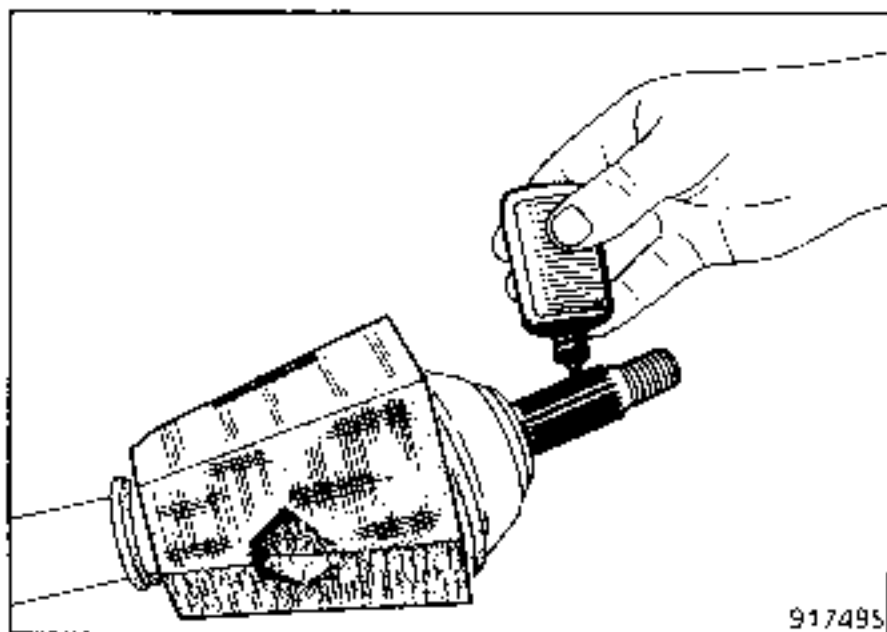

Fit the driveshaft stub axle into the hub.

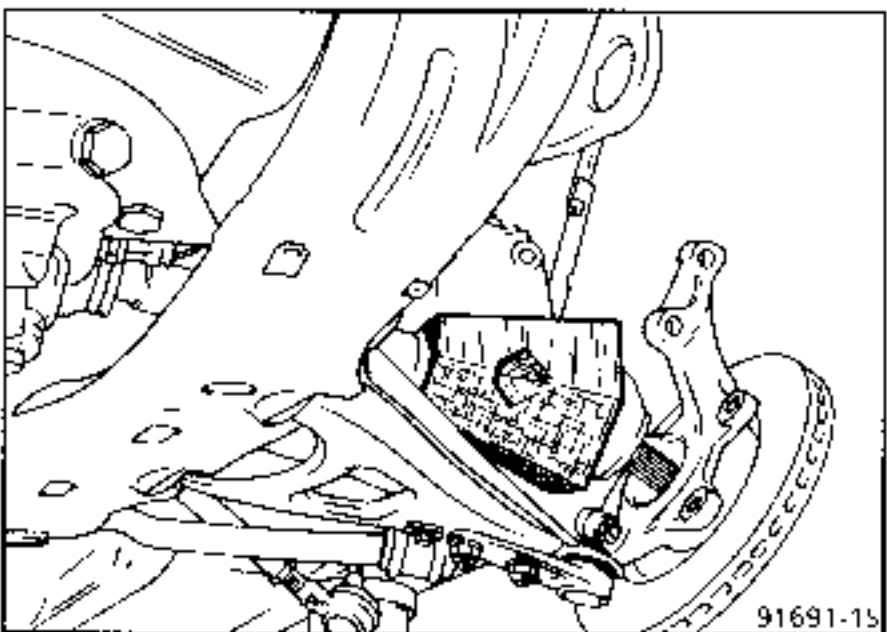
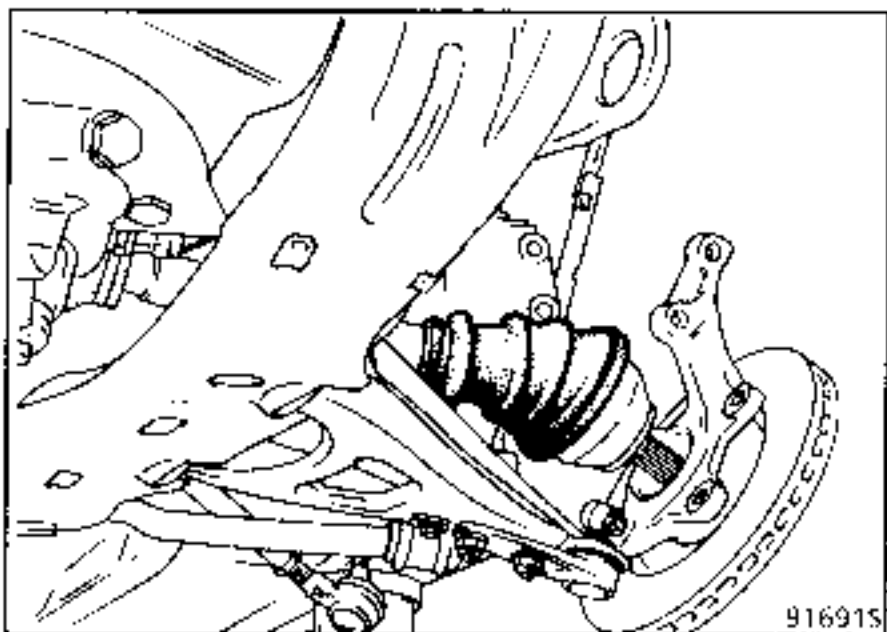

Refit:

- the 2 shock absorber base bolts to the stub axle carrier and tighten them to the correct torque, the track rod end and tighten the nut to the correct torque.

Lock the driveshaft nut to the correct torque using tool **Rou. 604-01**.

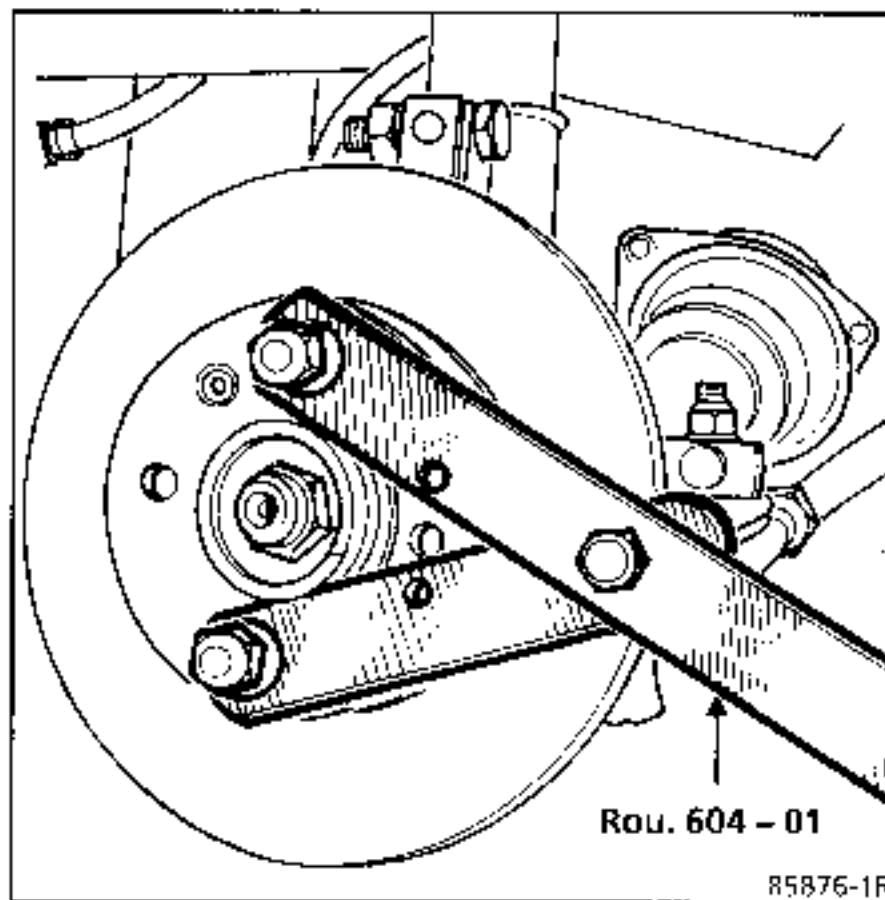

On the left hand side:

Clean the gaiter seating on the gearbox, refit the gaiter and the plate. Position the gaiter as horizontally as possible and torque tighten the three bolts.

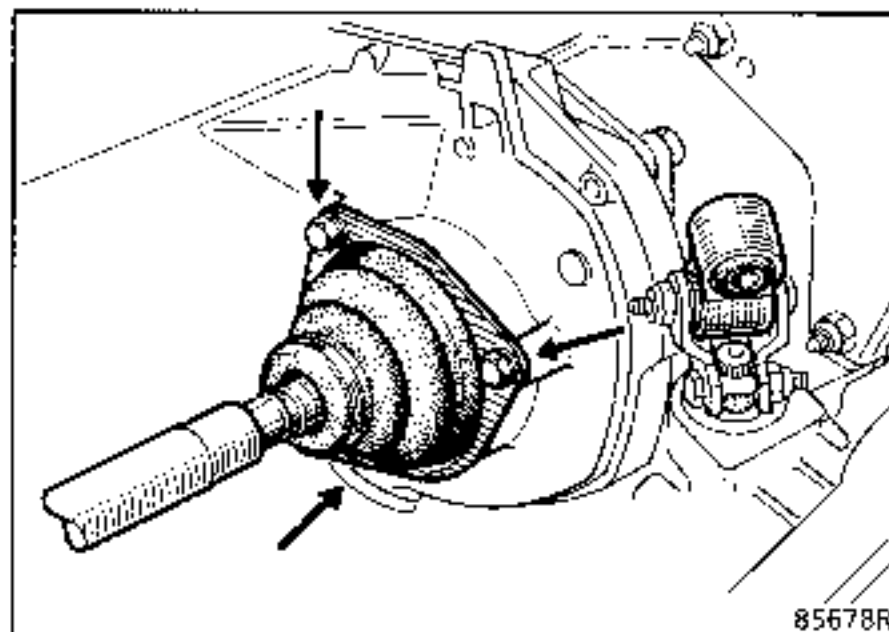

REPLACEMENT (cont)

On both sides:

Fit the brake calipers, coat the bolts with **LOCTITE FRENBLOC** and torque tighten them.

Return the vehicle to its wheels.

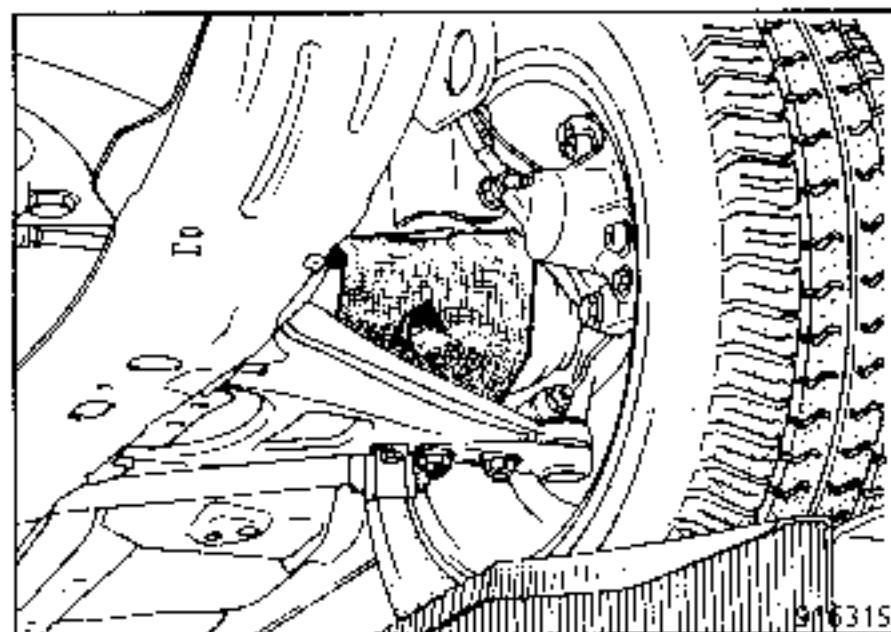
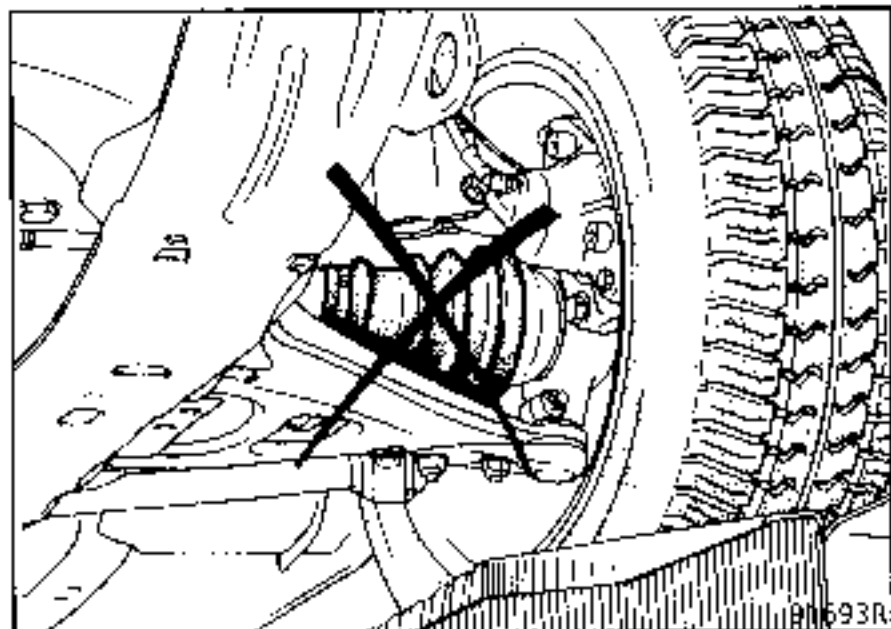

With the vehicle on its wheels, remove the cardboard protectors by tearing them as shown in the diagram.

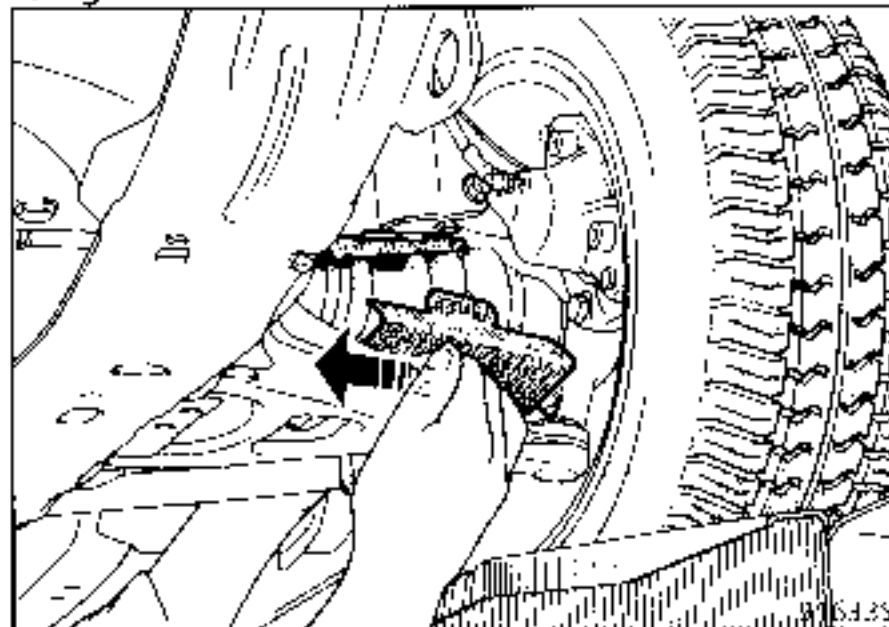

Never use a sharp edged instrument which could damage the gaiter.

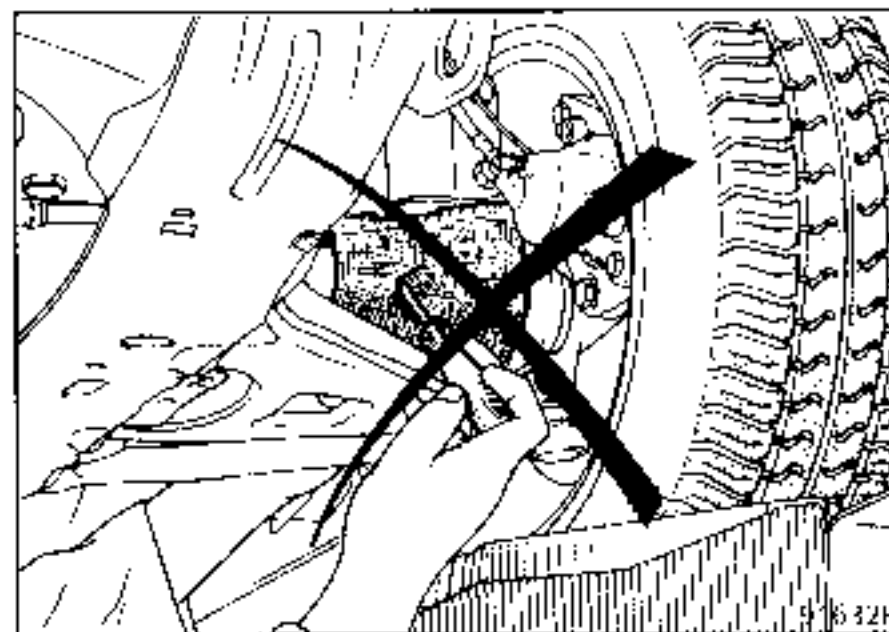

Press the brake pedal several times to bring the piston into contact with the linings.

If the left hand driveshaft has been removed, top up the gearbox with oil.

REPLACEMENT

SPECIAL TOOLING REQUIRED		
B.Vi.	31-01	Roll pin punch
Rou.	604-01	Hub locking tool
T.Av.	476	Ball joint extractor
T.Av.	1050-02	Driveshaft extractor

TIGHTENING TORQUES (in daN.m)		
Driveshaft nut		25
Wheel bolts	4 bolts	9
	5 bolts	10
Shock absorber base nut		20
Brake caliper mounting bolt		10
Track rod end nut		4

REMOVAL

Remove:

- the brake assembly (suspend it from the chassis to avoid damaging the brake hose),
- the driveshaft nut using tool **Rou. 604-01**.

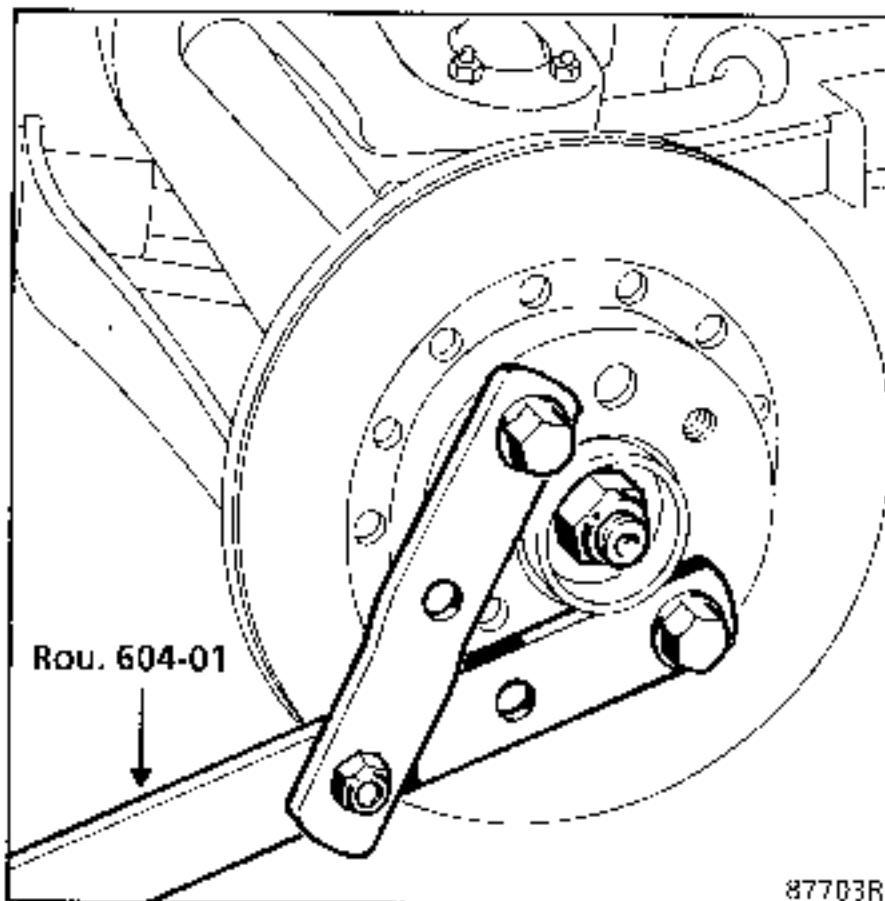

- the roll pins at the gearbox end using tool **B.Vi.31-01**,

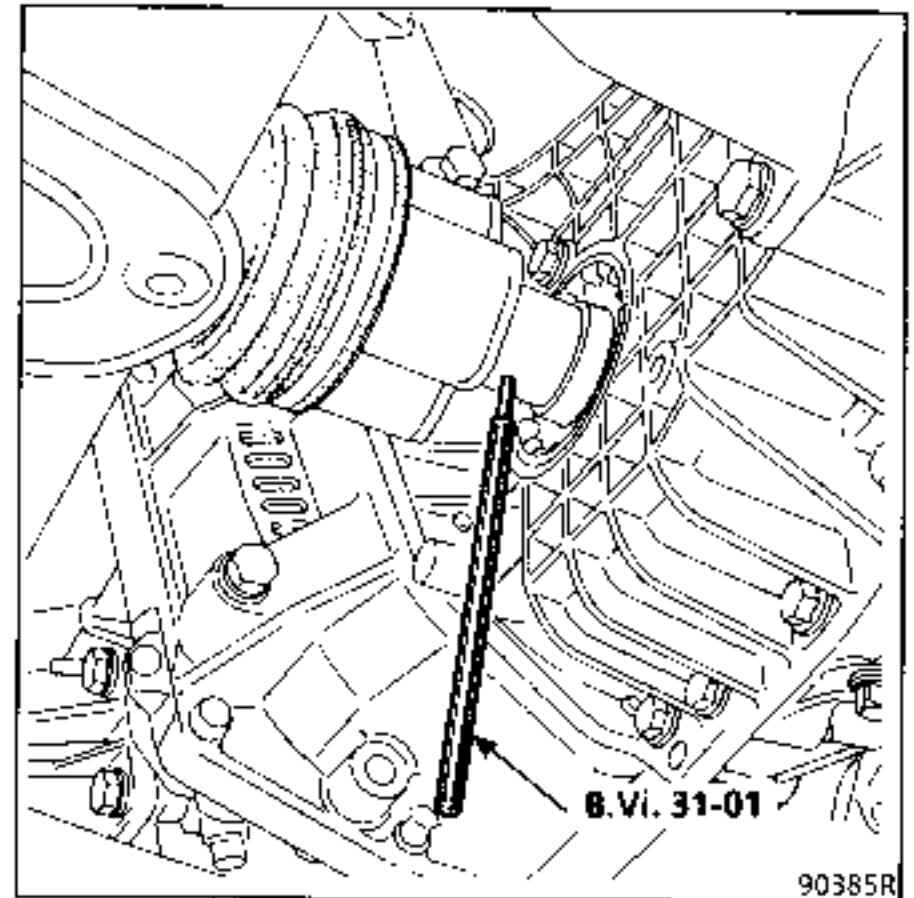

- the track rod end using tool **T.Av. 476**,

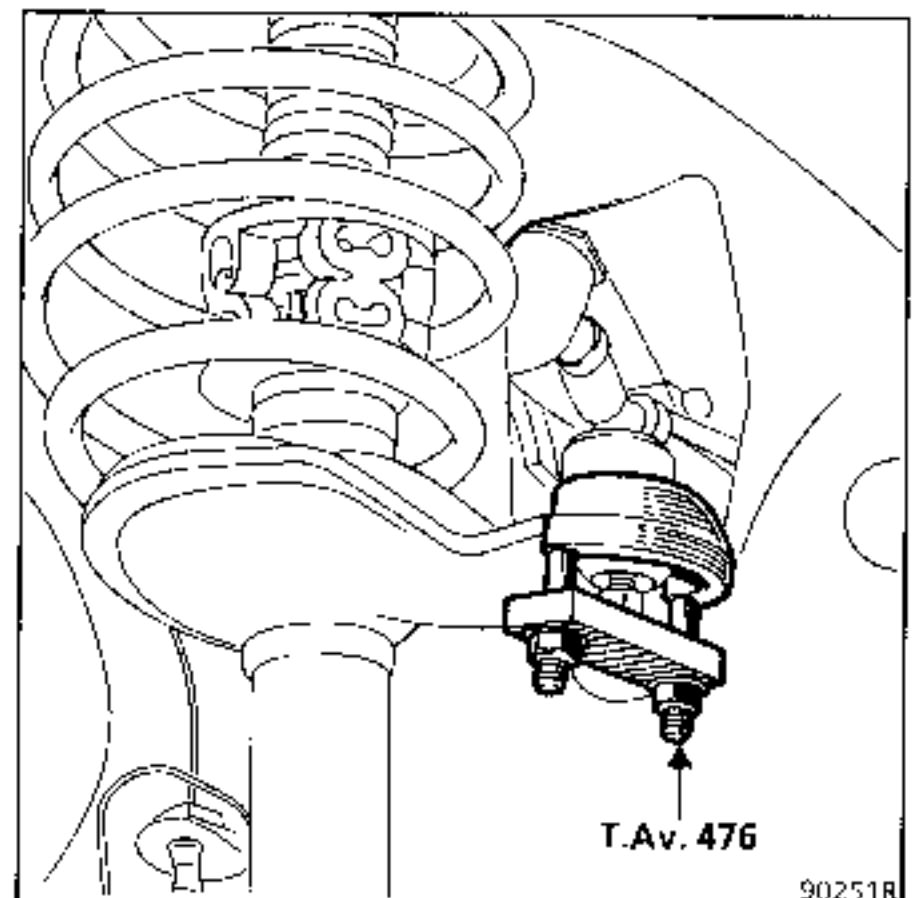

REPLACEMENT (cont)

- the upper shock absorber base mounting bolt.

Slacken but do not remove the lower bolt.

These vehicles are fitted with bonded driveshafts, which will need to be pushed back using tool T.Av. 1050-02.

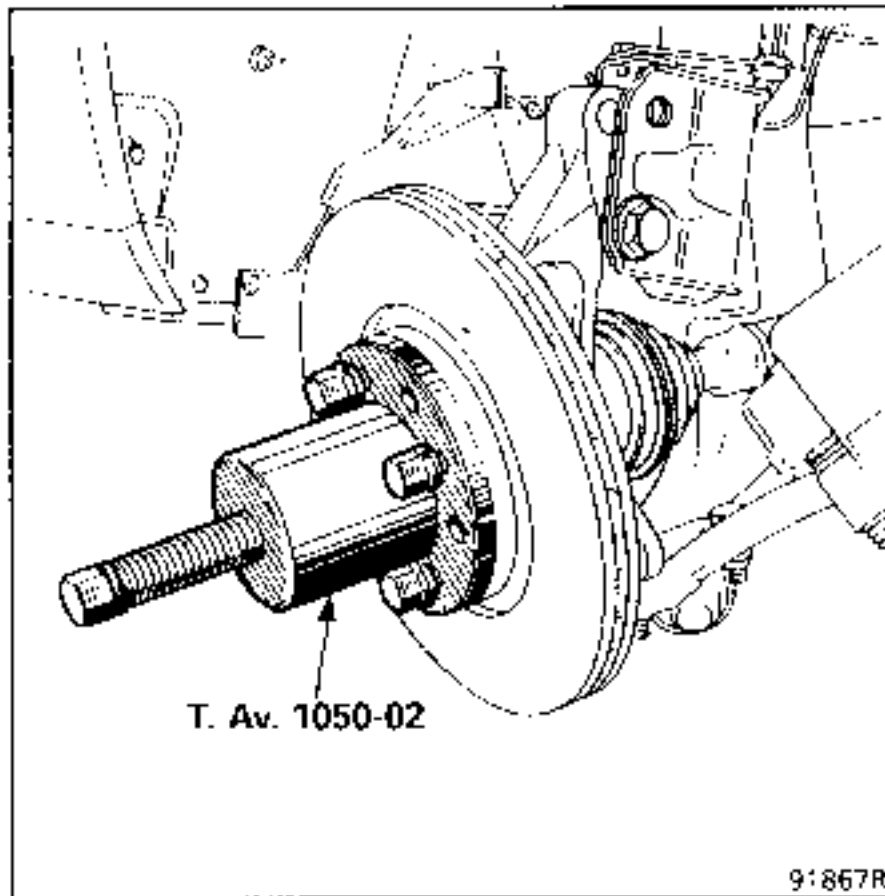

Tilt the stub axle carrier and remove the driveshaft.

Take care not to damage the gaiters during this operation.

REFITTING

NOTE : the Parts Department now supplies driveshafts fitted with protectors and with fitting instructions. These instructions must be followed to ensure that the assembly is correct and of the highest **QUALITY**. Remember that the slightest knock on the gaiters causes the rubber to break and the driveshaft to be damaged in the long term.

Never remove the cardboard protectors before the end of the operation to refit the driveshaft to the vehicle.

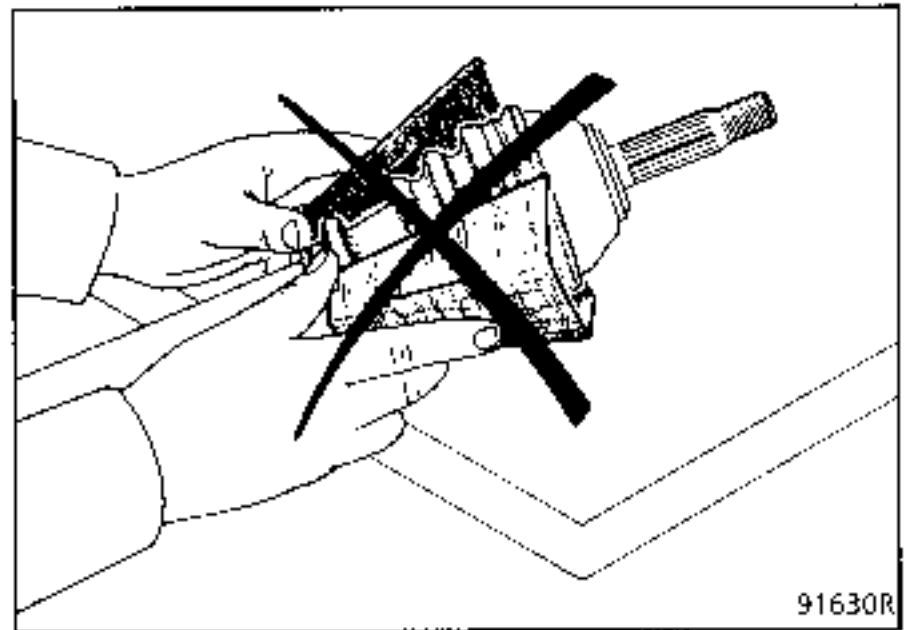

Never use an instrument with a sharp edge which could damage the gaiter.

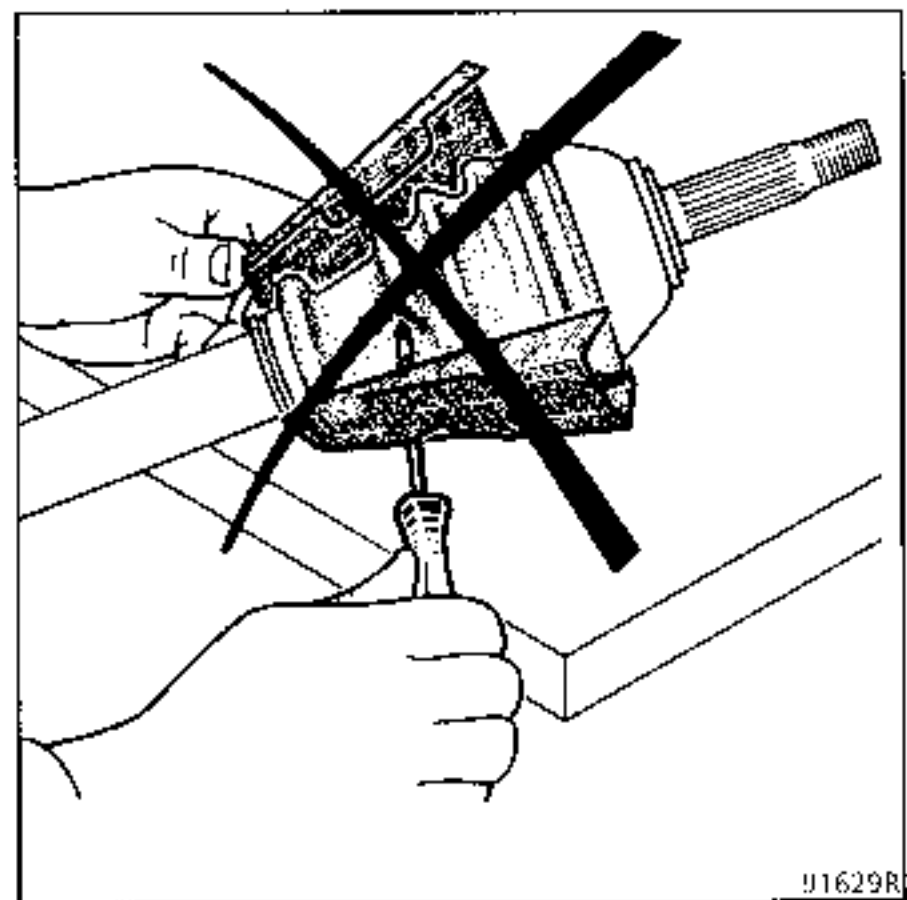

With the protector in position, coat the splines of the joint at the gearbox or AT end with **MOLYKOTE BR2**.

Ensure that the rubber washer is present between the end of the sunwheel and the base of the driveshaft yoke.

REPLACEMENT (cont)

Position the driveshaft in relation to the sunwheel and engage it.

Check its position using the angled pin **B.Vi. 31-01**.

Fit two new roll pins, using tool **B.Vi. 31-01**. Seal the roll pin holes using **RHODORSEAL 5661** (eg-**CAF 4/60 THIXO**).

Special notes for NG gearboxes and AT MJ

An inlet chamfer on the sunwheels makes it easier to fit the new roll pins.

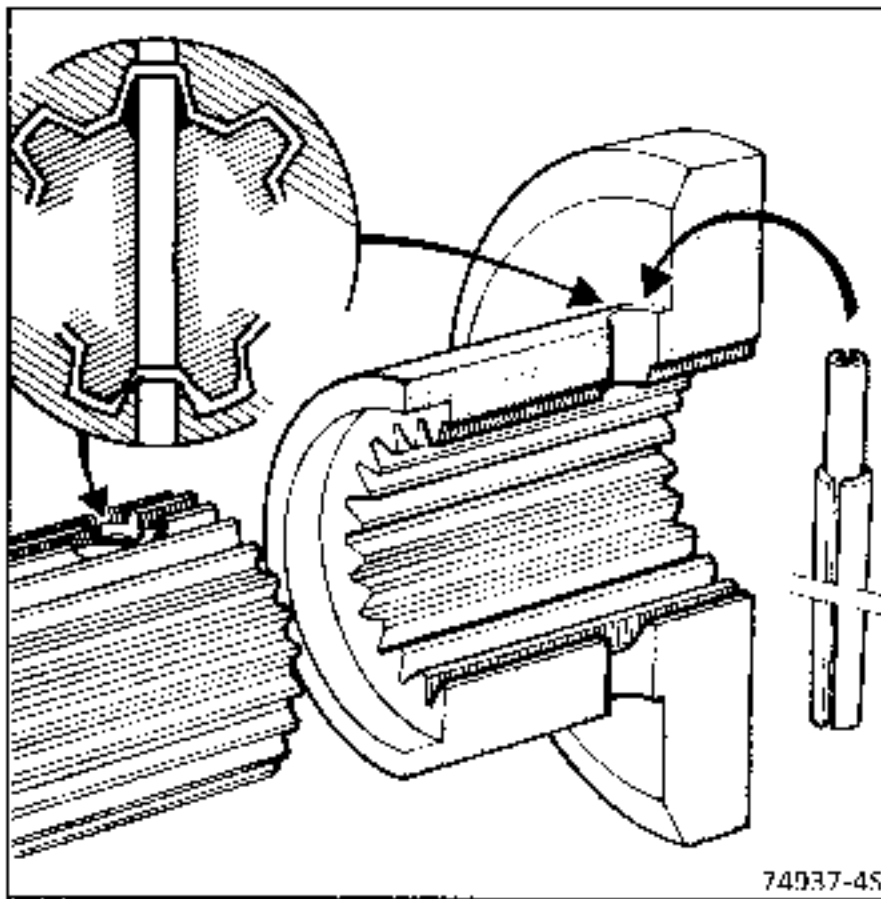

Coat the stub axle splines with **LOCTITE SCELBLOC**.

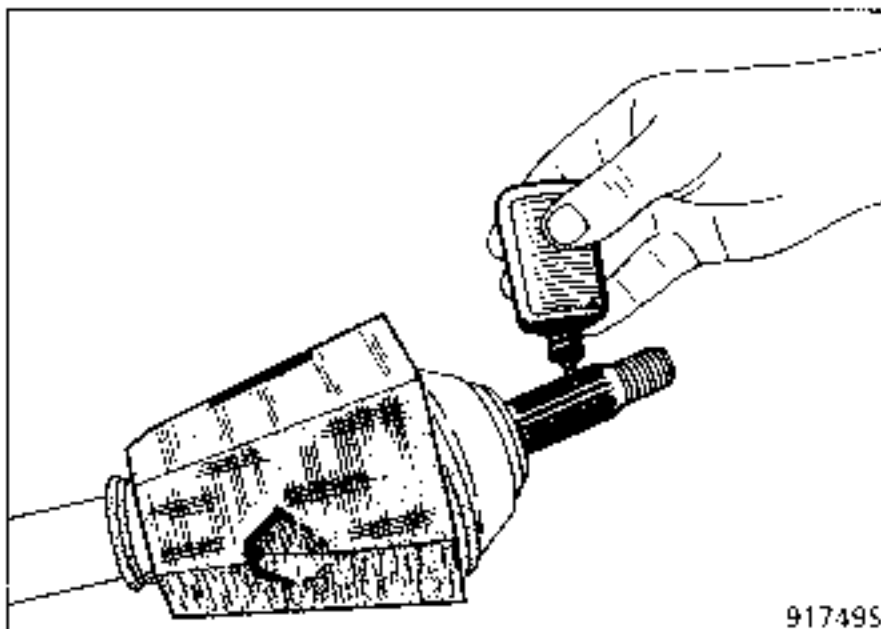

Fit the driveshaft stub axle into the hub.

Refit:

- the 2 shock absorber base bolts to the stub axle carrier and tighten them to the correct torque,
- the track rod end and tighten the nut to the correct torque.

Fit the brake calipers, coat the bolts with **LOCTITE FRENBLOC** and torque tighten them.

Lock the driveshaft nut to the correct torque using tool **Rou. 604-01**.

Return the vehicle to its wheels.

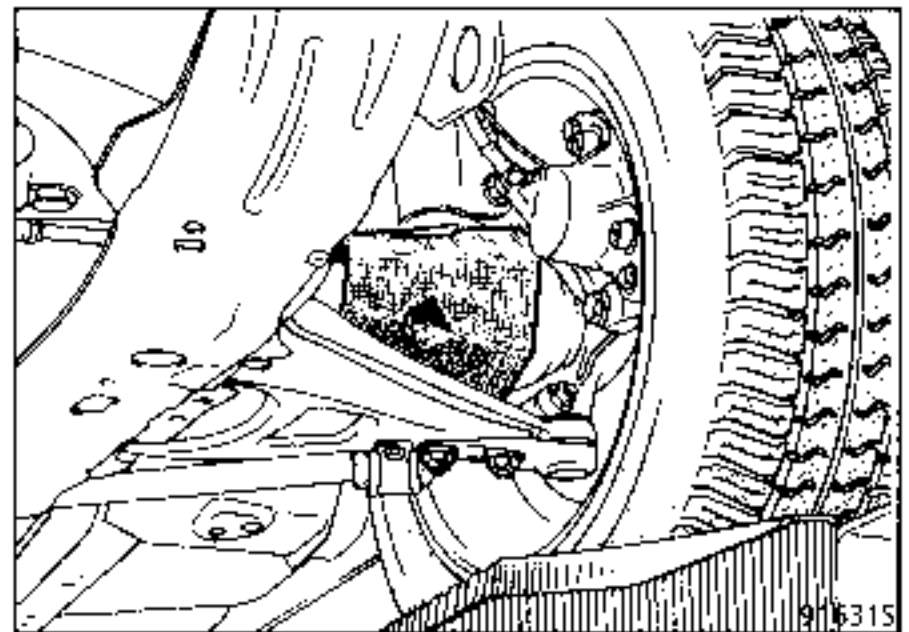
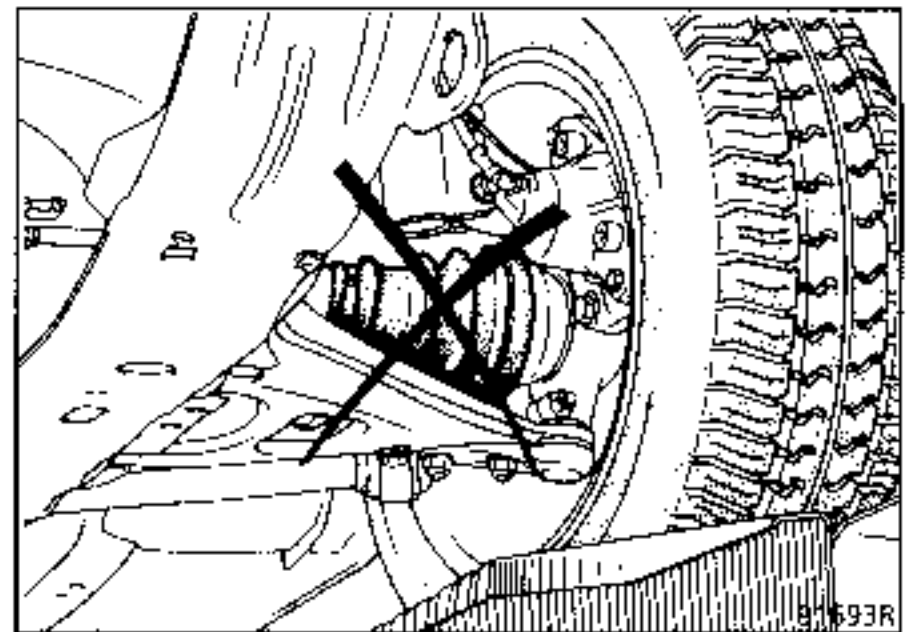

REPLACEMENT (cont)

With the vehicle on its wheels, remove the cardboard protectors by tearing them as shown in the diagram.

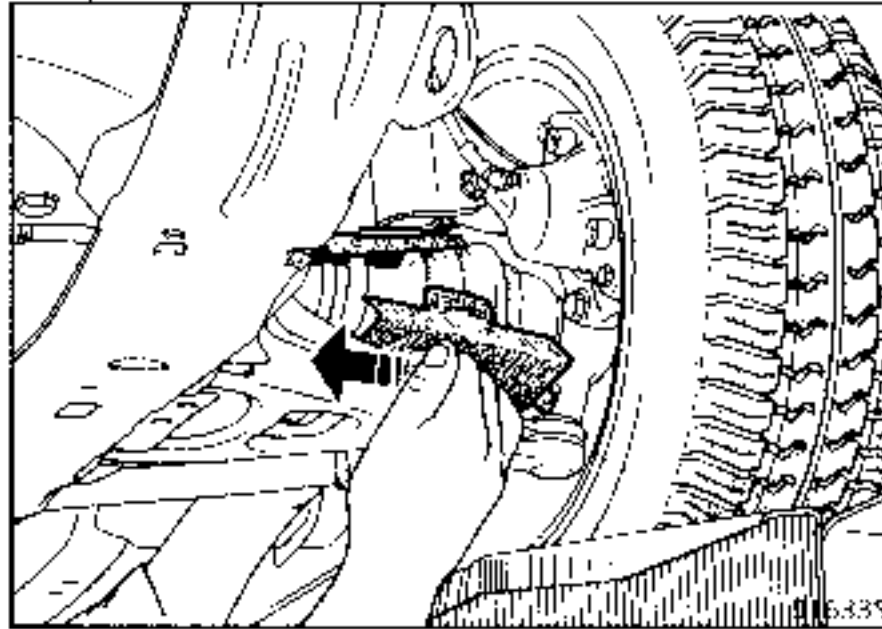

Never use a sharp edged instrument which could damage the gaiter.

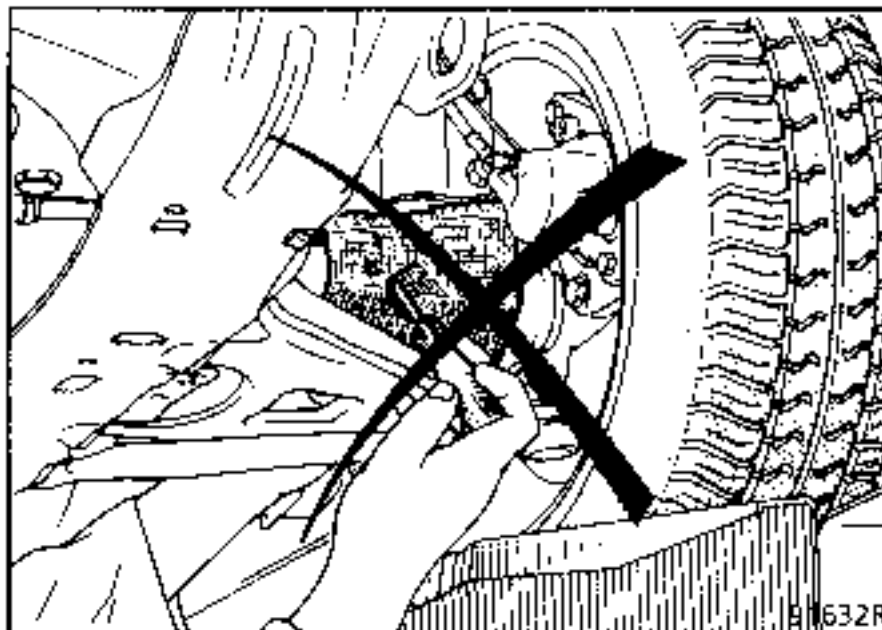

Press the brake pedal several times to bring the piston into contact with the linings.

REPLACEMENT

SPECIAL TOOLING REQUIRED

Rou.	604-01	Hub locking tool
T.Av.	1050-02	Driveshaft extractor

TIGHTENING TORQUES (in daN.m)



Driveshaft nut	21
Mounting bolt on sunwheel	6
Wheel bolts	9

REMOVAL

Tool Rou. 604-01 in position, remove:
- the driveshaft nut,

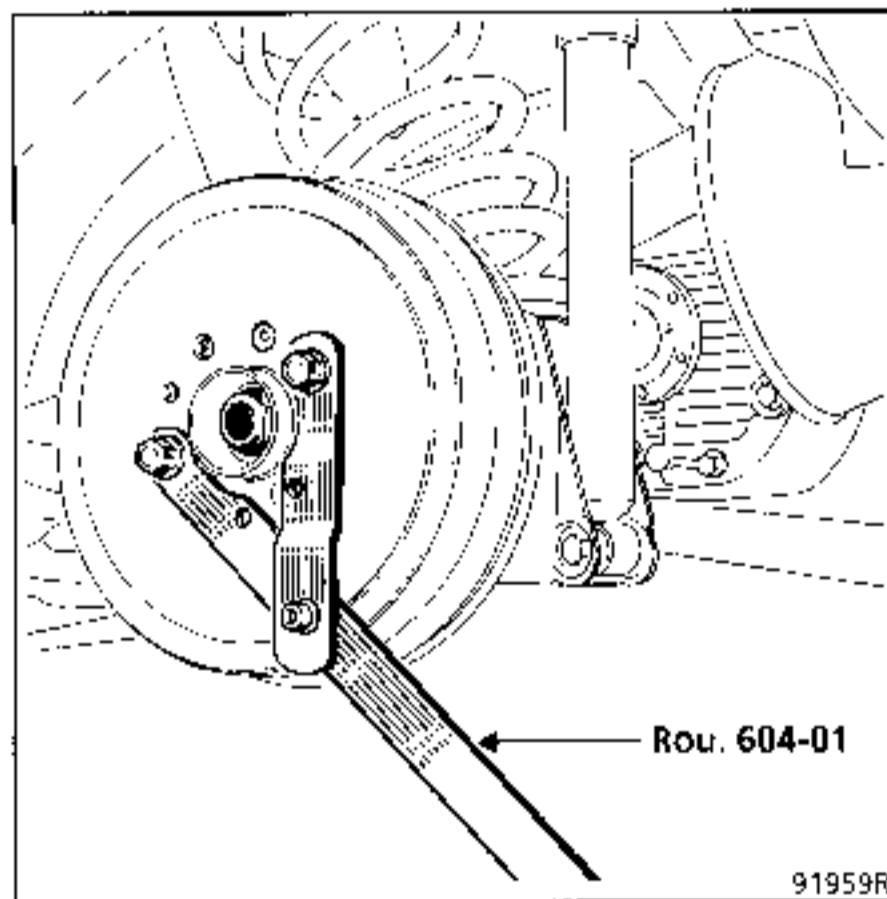

- the six mounting bolts (A) on the sunwheel.

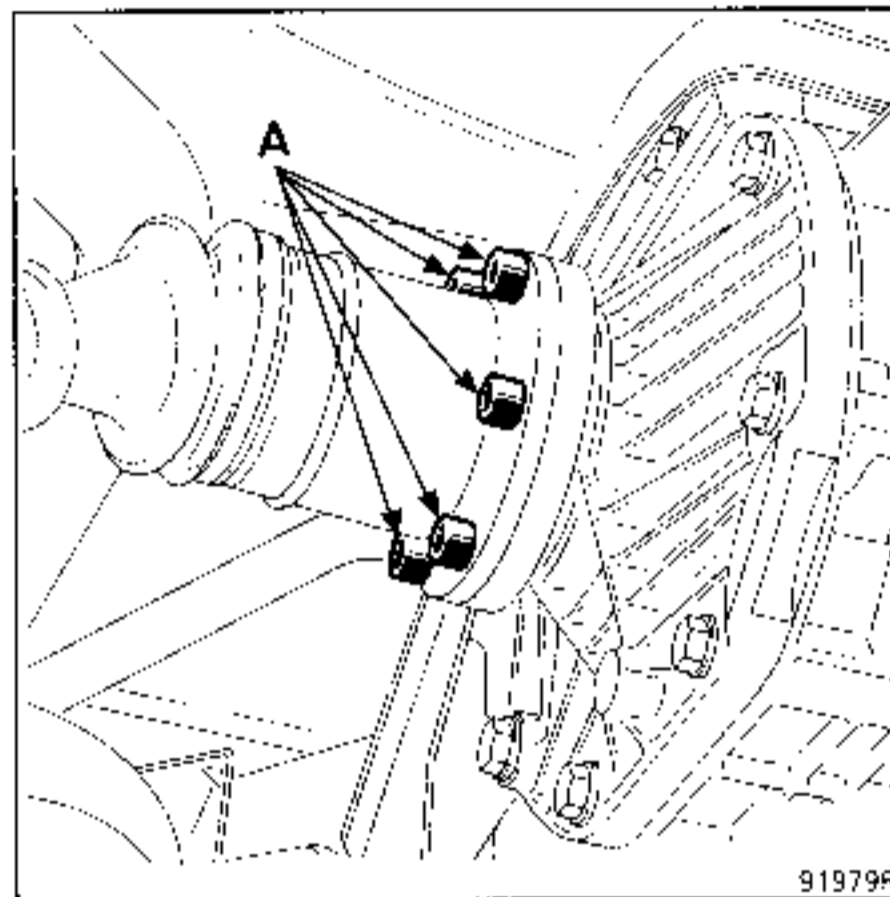

These vehicles are fitted with bonded driveshafts, which will need to be pushed back using tool T.Av. 1050-02.

Remove the driveshaft:
tools T.Av. 1050-02 + Rou. 604-01.

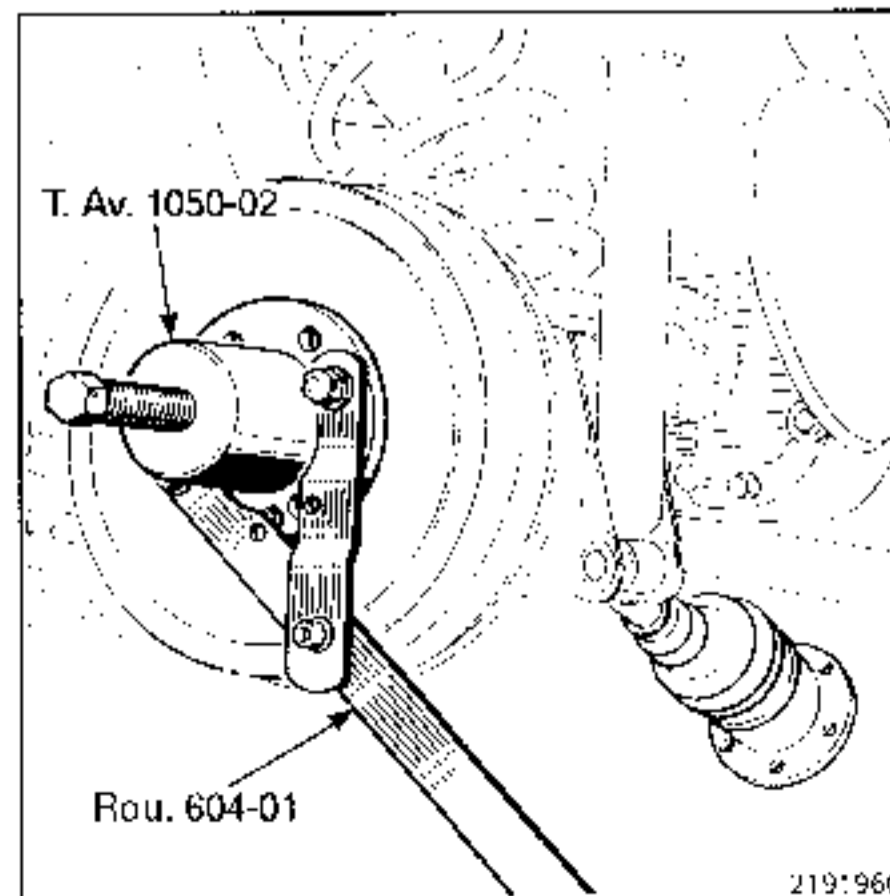

REPLACEMENT (cont)

REFITTING

NOTE : the Parts Department now supplies driveshafts fitted with protectors and with fitting instructions. These instructions must be followed to ensure that the assembly is correct and of the highest **QUALITY**. Remember that the slightest knock on the gaiters causes the rubber to break and the driveshaft to be damaged in the long term.

Never remove the cardboard protectors before the end of the operation to refit the driveshaft to the vehicle.

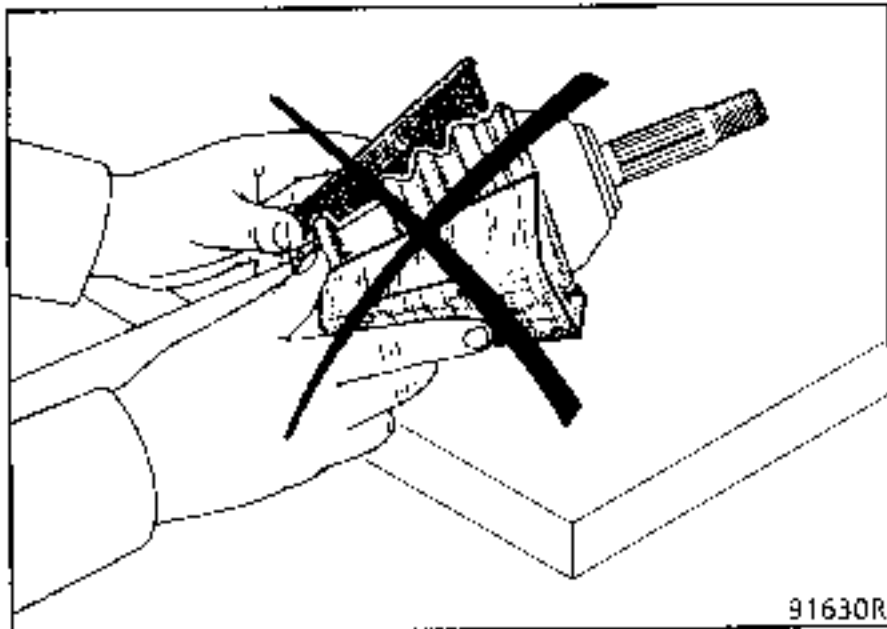

91630R

Never use an instrument with a sharp edge which could damage the gaiter.

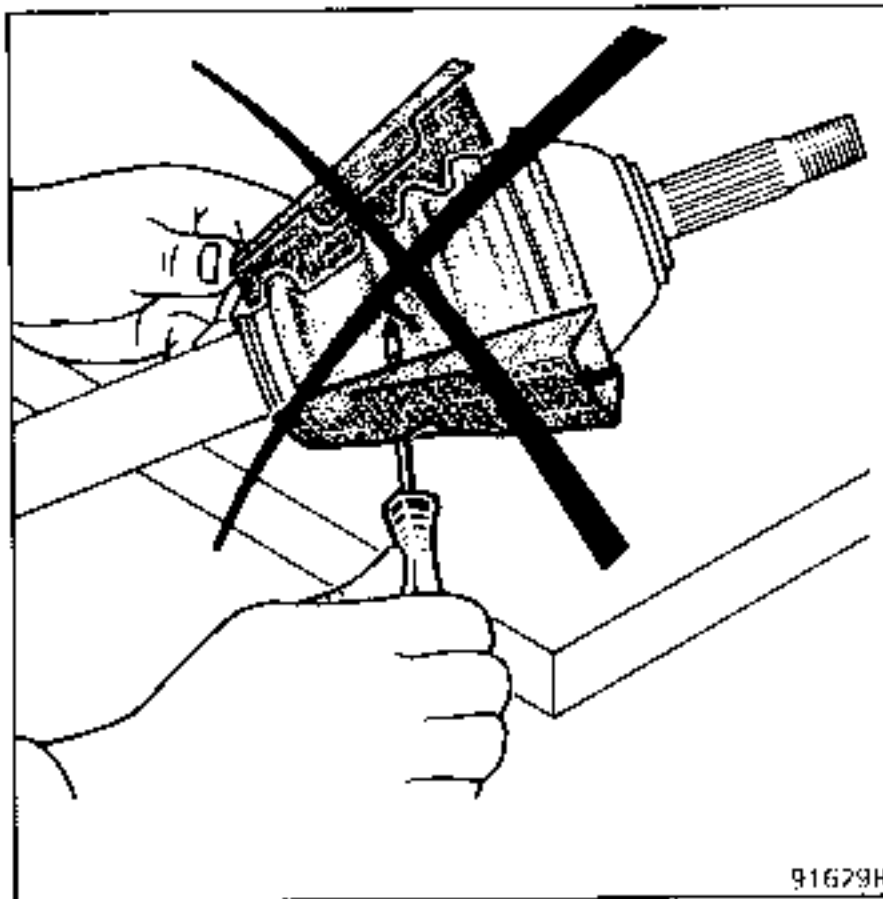

91629R

Coat the stub axle splines with **LOCTITE SCELBLOC**.

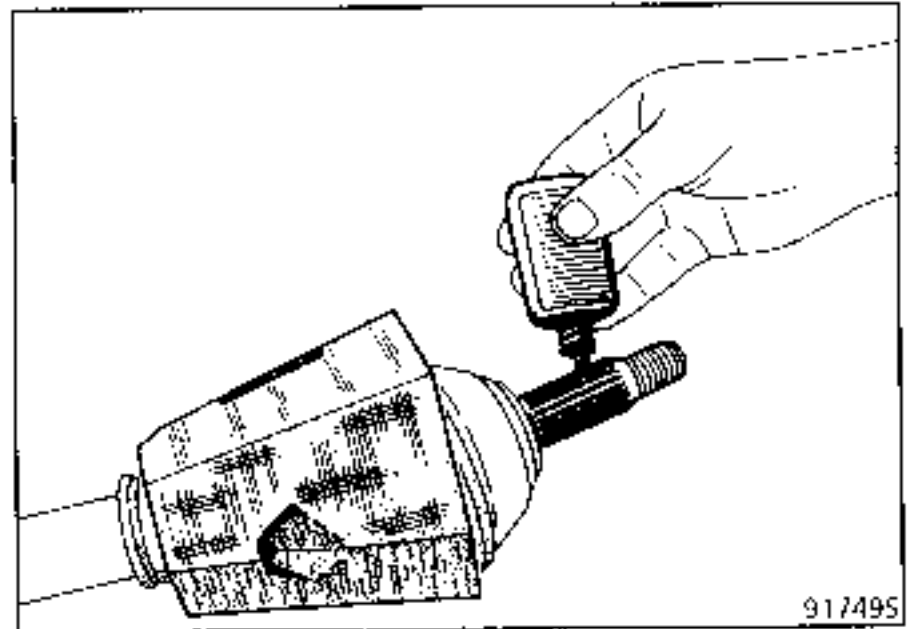

91749S

Fit the driveshaft stub axle into the hub.

Secure the driveshaft to the sunwheel (six bolts (A) and tighten to the recommended torque, tool Rou. 604-01).

With the vehicle on its wheels, remove the cardboard protectors.

REPLACEMENT

SPECIAL TOOLING REQUIRED	
T.Av. 537-02	GE 86 expander
T.Av. 586-01	GE 76 expander
T.Av. 1034	Pliers for crimping OETIKER driveshaft clips

- 1 Stub axle bowl
- 2 Retaining starplate
- 3 Spider
- 4 Shaft yoke
- 5 Retaining clip
- 6 Rubber gaiter
- 7 Retaining collar

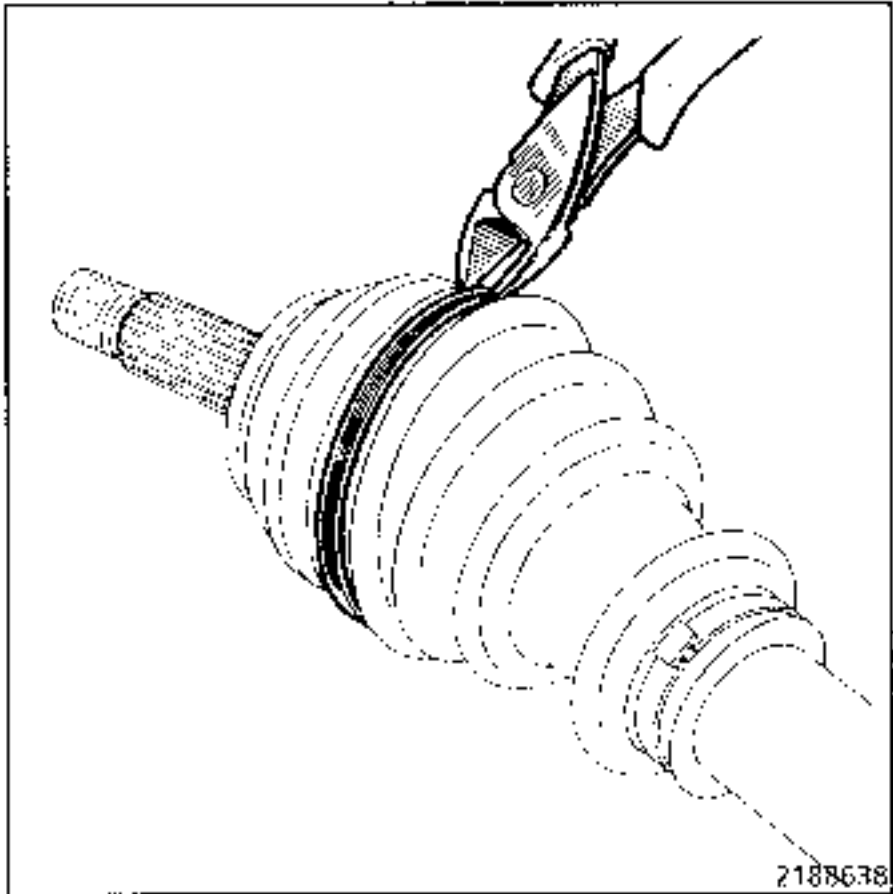
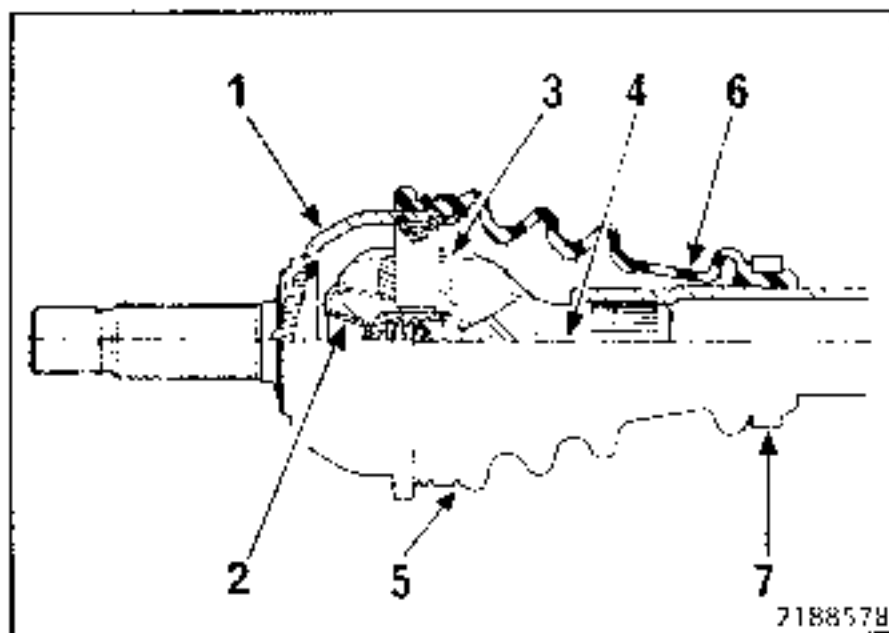

Remove as much grease as possible.

Release the stub axle bowl from the driveshaft by lifting the starplate arms (2) one after the other.

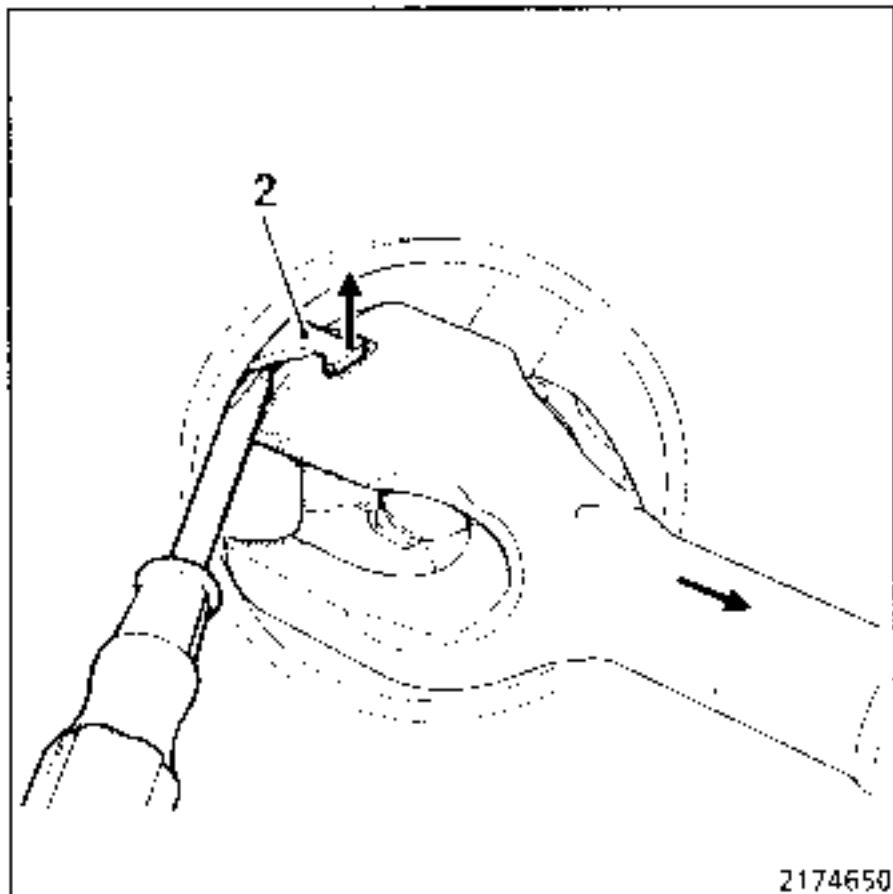

REMOVAL

Cut the collars, taking care to avoid damaging the grooves in the stub axle bowl.

REPLACEMENT (cont)

DO NOT TWIST THE STARPLATE ARMS.

Retain the thrust ball, the spring and the shim under the ball joint (B).

NOTE : the thickness of the shim under the ball joint is adapted to the original clearance.

This shim should be retained and used on refitting.

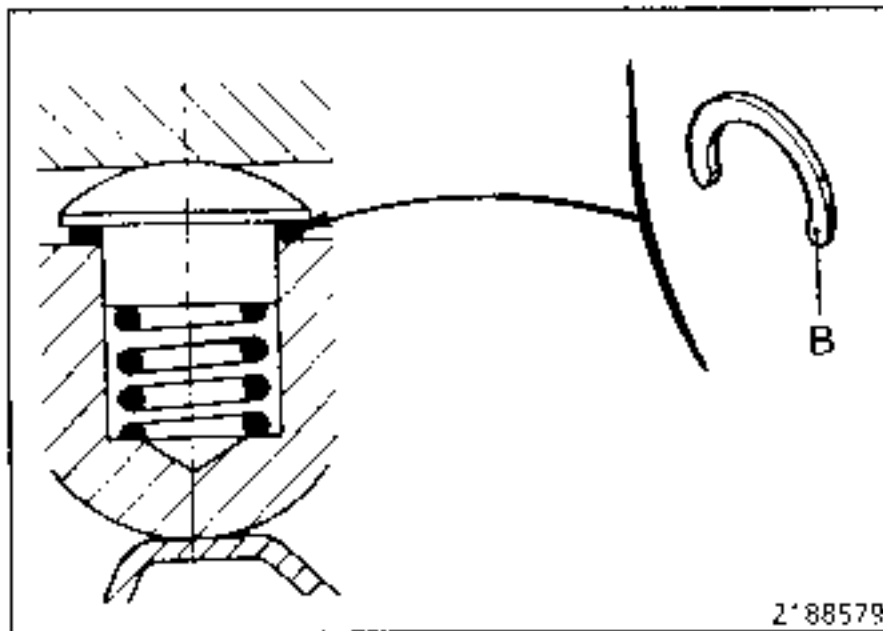

Remove all traces of grease.

REFITTING

Fitting the gaiter requires the use of the following tools:

- T.Av. 537-02 for GE 86,
- T.Av. 586-01 for GE 76.

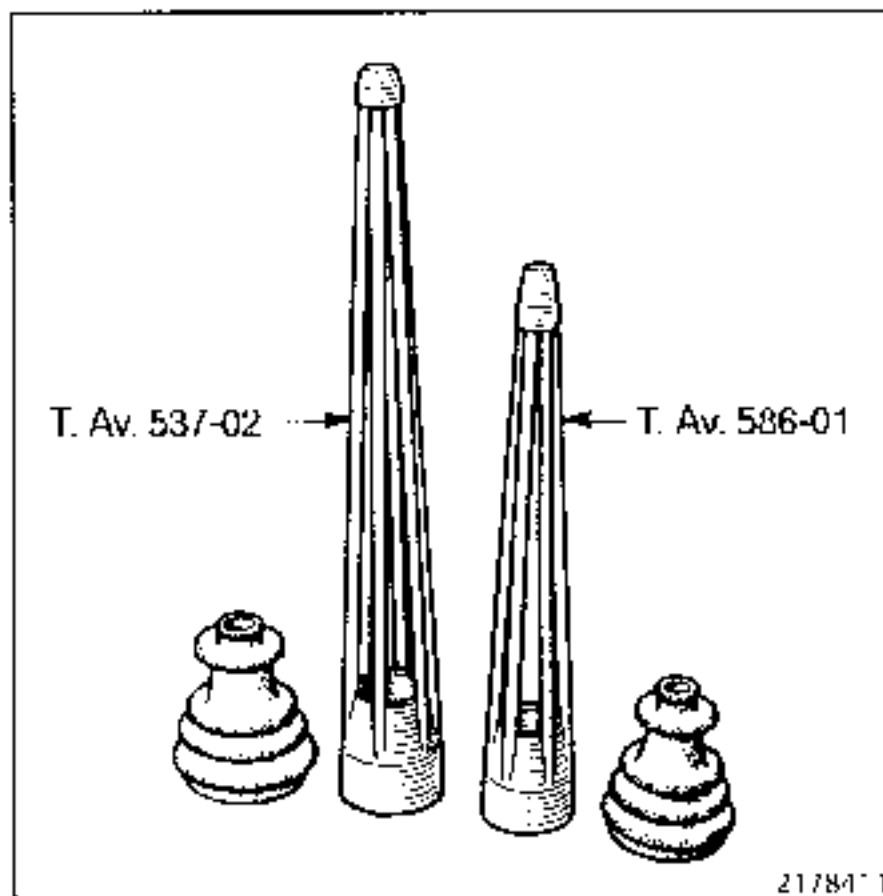

Hold the driveshaft at a convenient angle in a vice fitted with soft jaws.

Fit the expander tool on the end of the yoke (if it will not fit, deburr the cylindrical section inside the expander with emery paper).

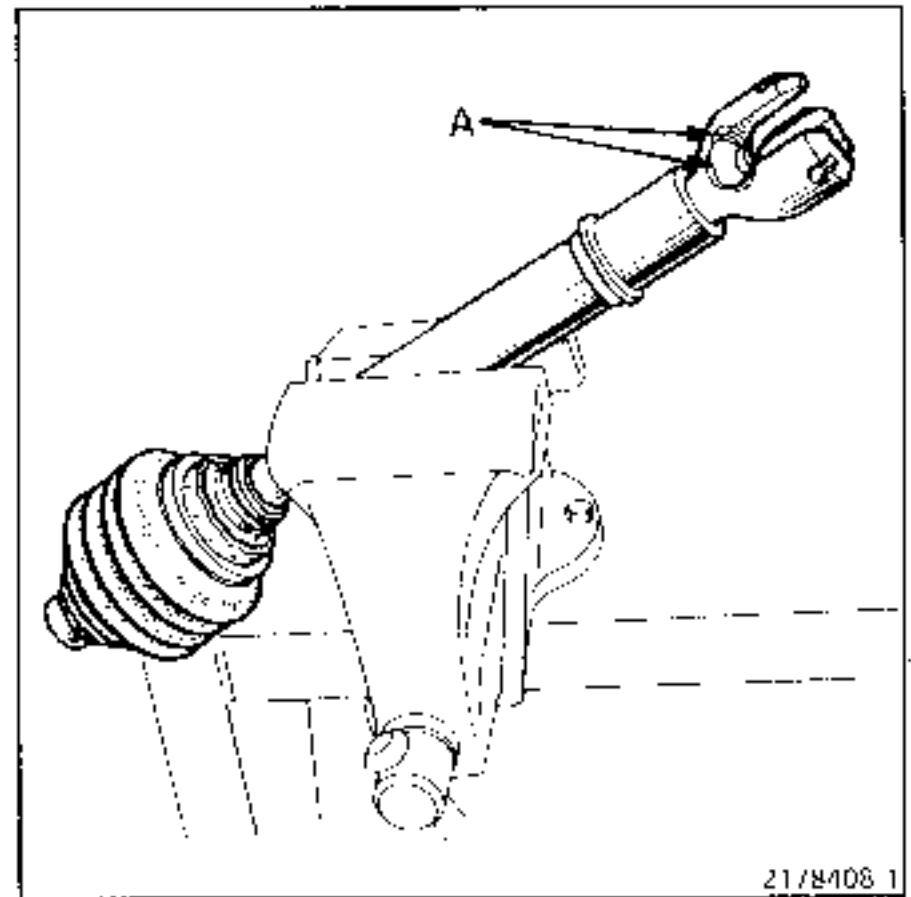

It is essential to ensure that there are no sharp edges on the yoke (A) (deburr lightly with emery paper if necessary).

Lubricate the following generously before assembly with clean automatic transmission oil:

- the tool assembly (stems and centre),
- the inside of the gaiter, in particular the neck.

Place a thumb over the bottom hole, pour some oil into the gaiter and spread it round the inside.

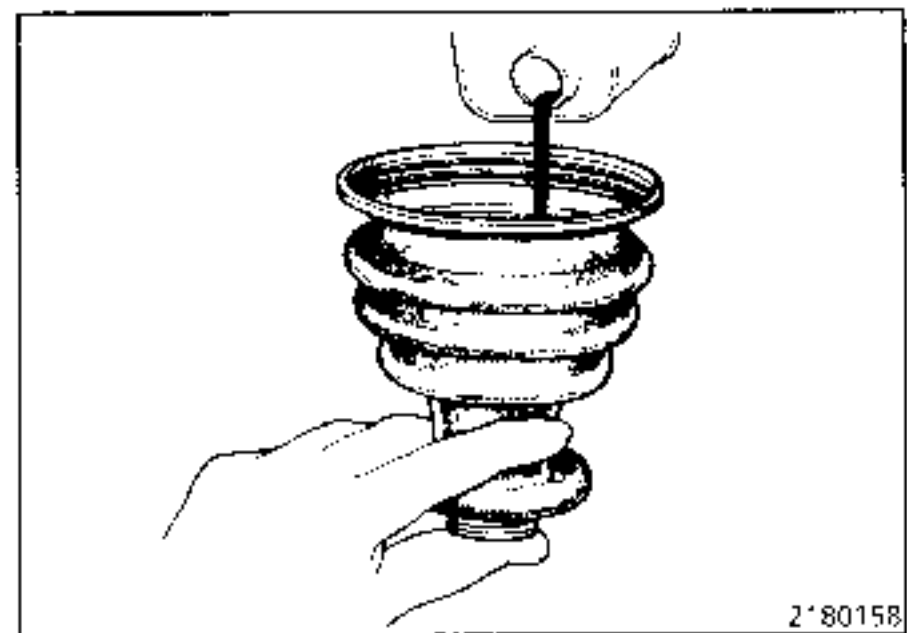

REPLACEMENT (cont)

Slip the gaiter over the end of the expander.

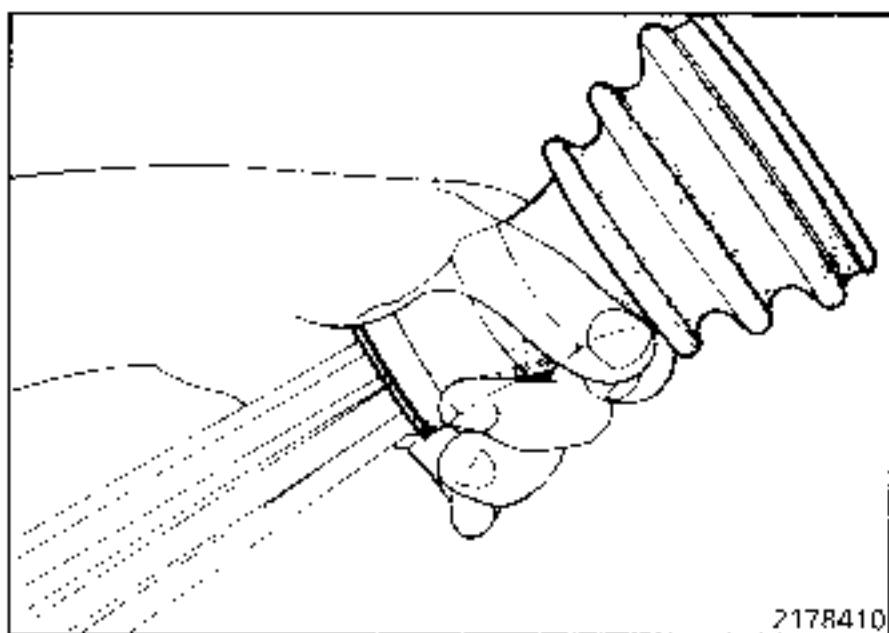

Wrap a piece of clean cloth around one hand and grip the gaiter so that the first fold will stretch when it is slid on.

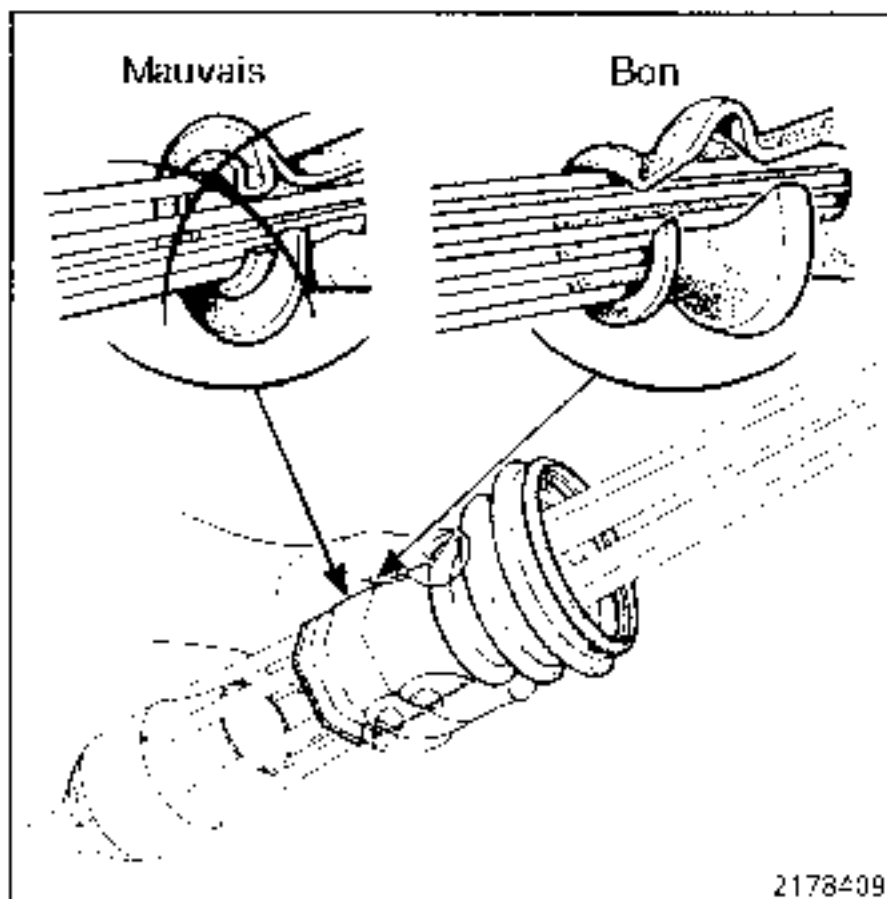

Lean your hip against the edge of the bench.

Place one hand around the other and pull, taking care that the first fold does not double back.

Pull the gaiter as far as possible towards the cylindrical part of the tool and then let it return halfway.

Repeat this operation several times (maximum 5 times) to make the gaiter rubber more pliable (re-lubricate the stems of the tool during the operation if required).

When the rubber feels more pliable and easy to slide, pull the gaiter in one movement on to the cylindrical part of the tool.

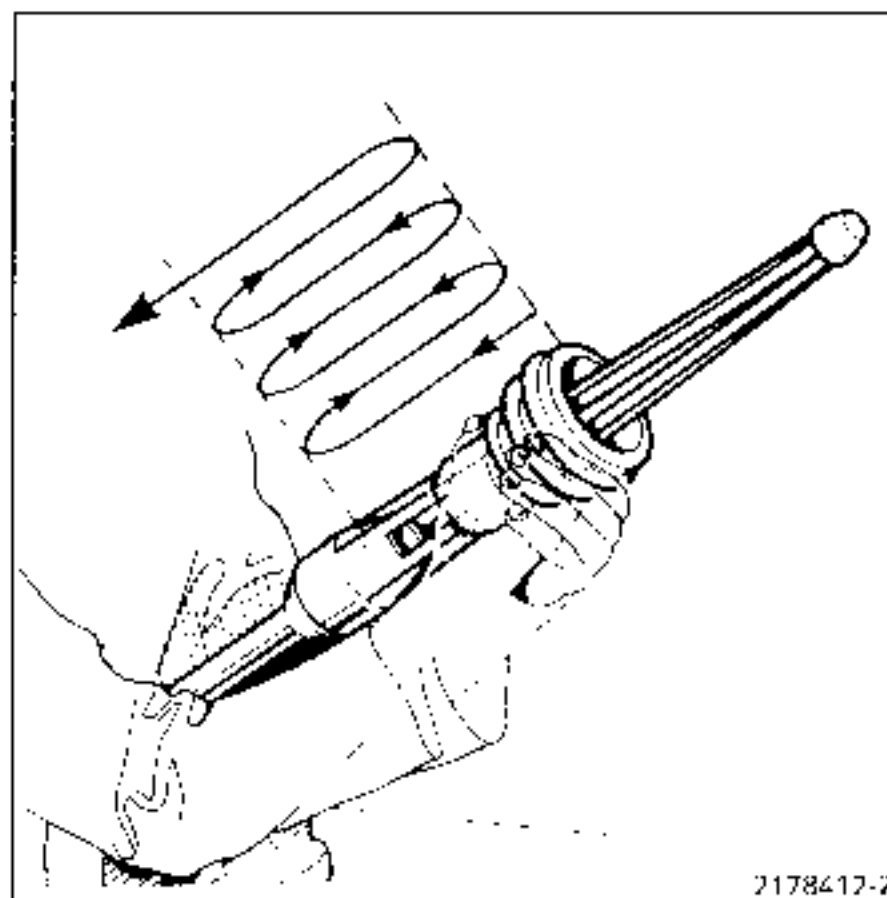

Fit the spring and thrust ball in the spider.

Move the rollers towards the centre.

REPLACEMENT (cont)

Position the retaining starplate (2), so that each arm is central between each spider trunnion.

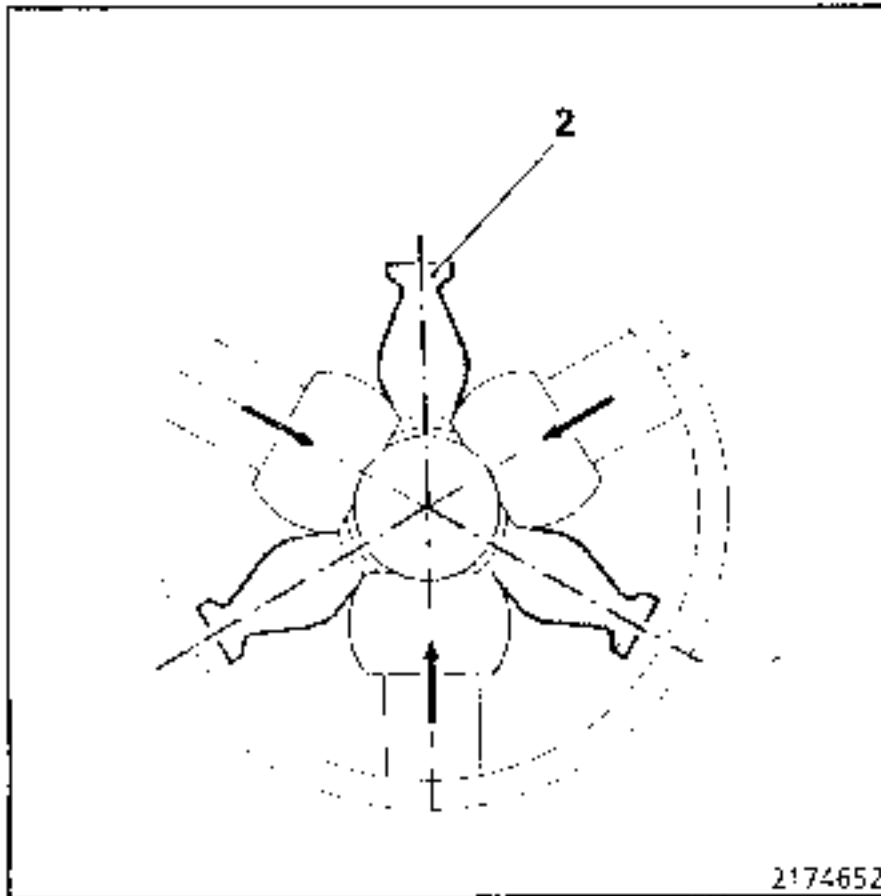

Insert the driveshaft yoke into the stub axle bowl.

Tilt the shaft to fit one arm of the starplate into a slot in the yoke, and press to centre it correctly.

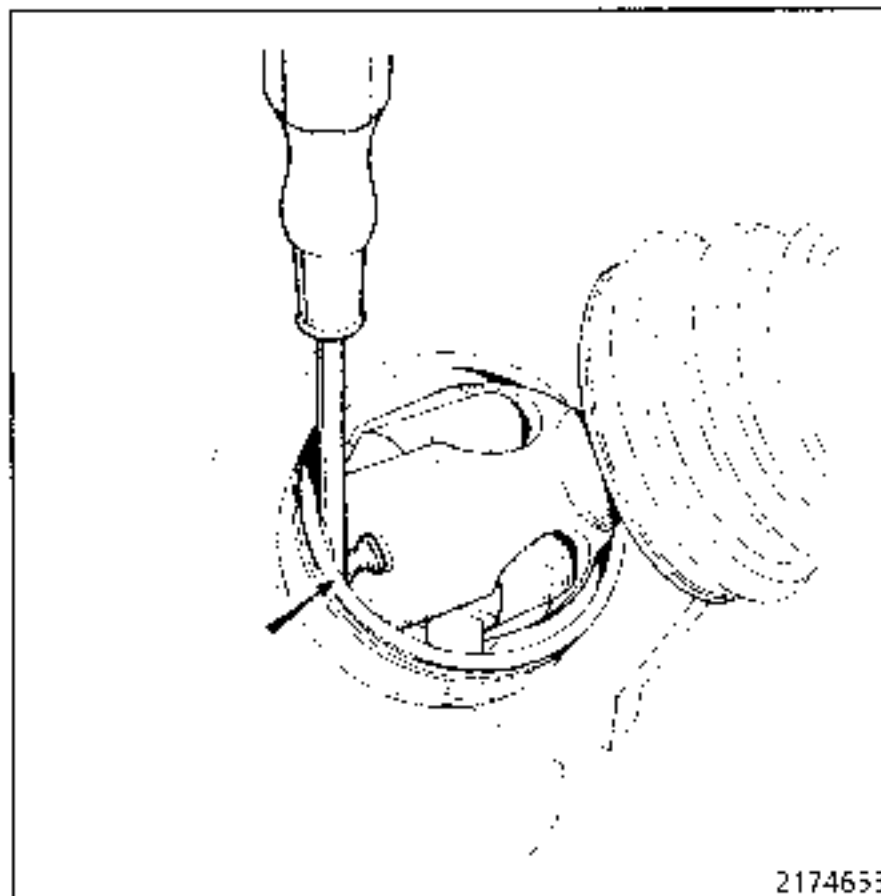

The other arms may be refitted more easily using a screwdriver modified as shown in the diagram.
A = 5 mm **B = 3 mm**

Ensure that the arms of the retaining starplate are correctly fitted in their locations.

Tilt the shaft in the plane of one of the starplate arms and the ball joint will be released under the action of the spring.

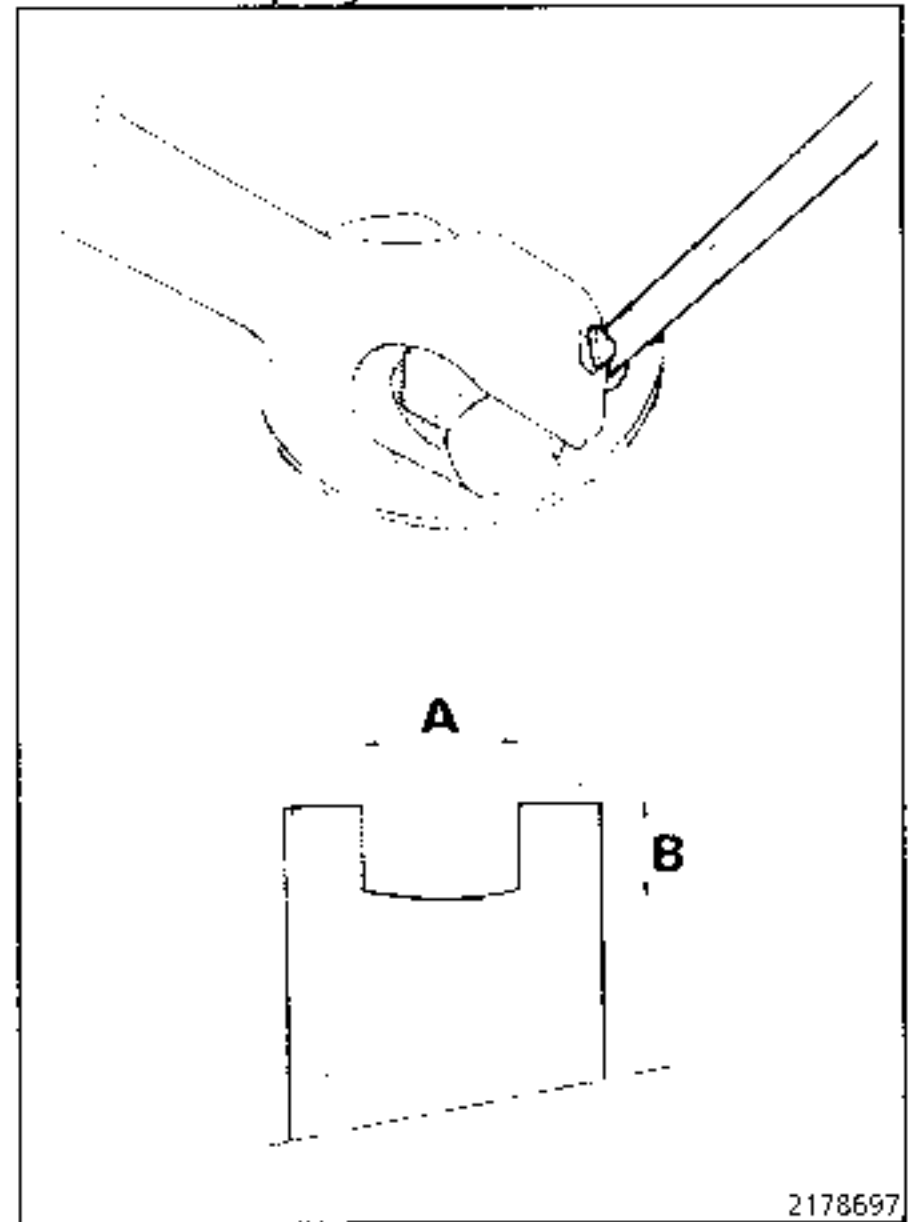

Insert the shim under the top of the ball joint (the shim should not project above the top of the ball joint).

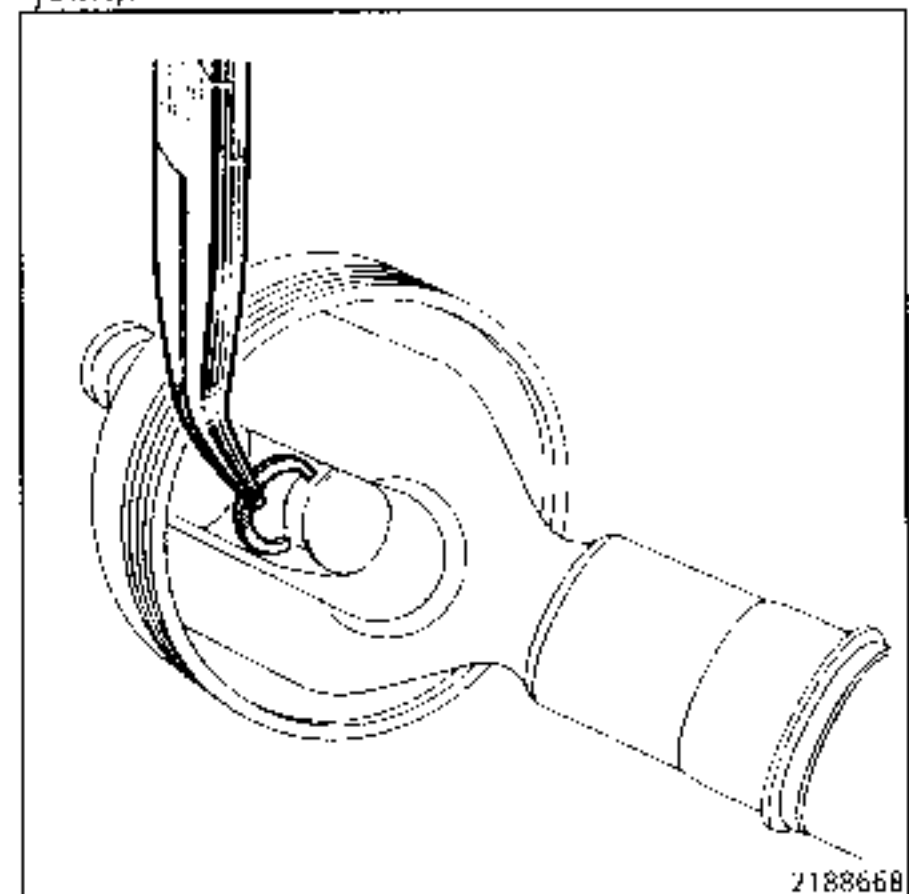

REPLACEMENT (cont)

Check that the joint moves correctly by hand.

There should be no points of resistance.

Spread the sachet of grease evenly between the gaiter and the stub axle bowl.

NOTE : Ensure that the amount of grease specified in the "Materials" section is used.

Position the gaiter lips in their grooves on the stub axle bowl and on the driveshaft.

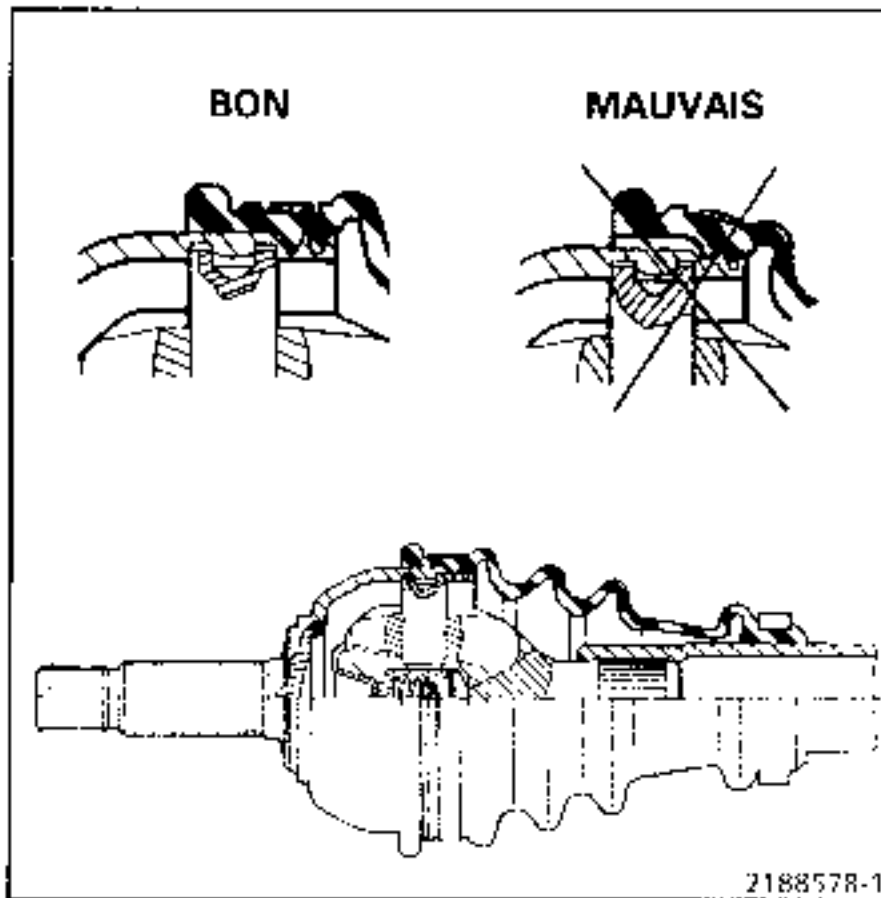

Insert a smooth round-edged rod between the gaiter and the driveshaft to correct the amount of air inside.

Fit the clips and tighten them using tool T.Av. 11034.

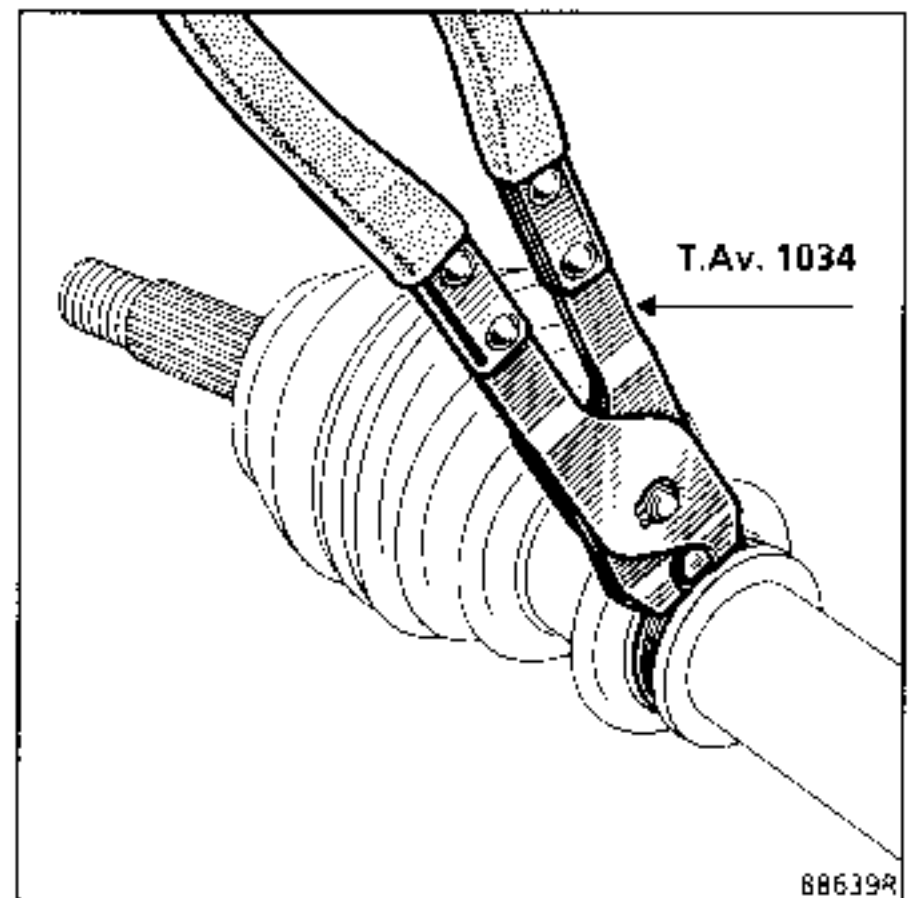
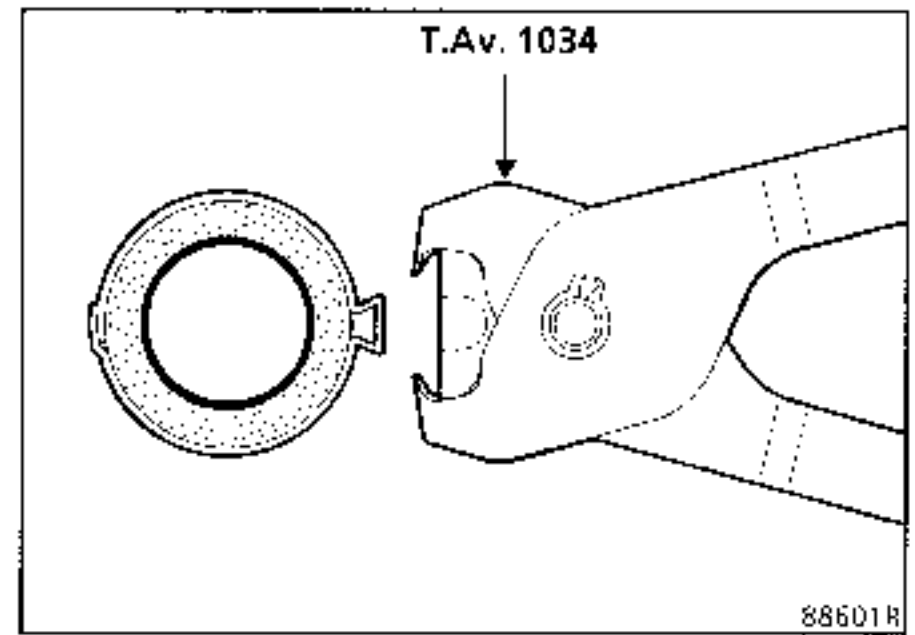

REPLACEMENT

SPECIAL TOOLING REQUIRED	
T.Av. 1168	Pliers for CAILLAU clips for driveshafts with thermoplastic gaiters

- 1 Stub axle bowl
- 2 Retaining starplate
- 3 Spider
- 4 Shaft yoke
- 5 Retaining clip
- 6 Thermoplastic gaiter

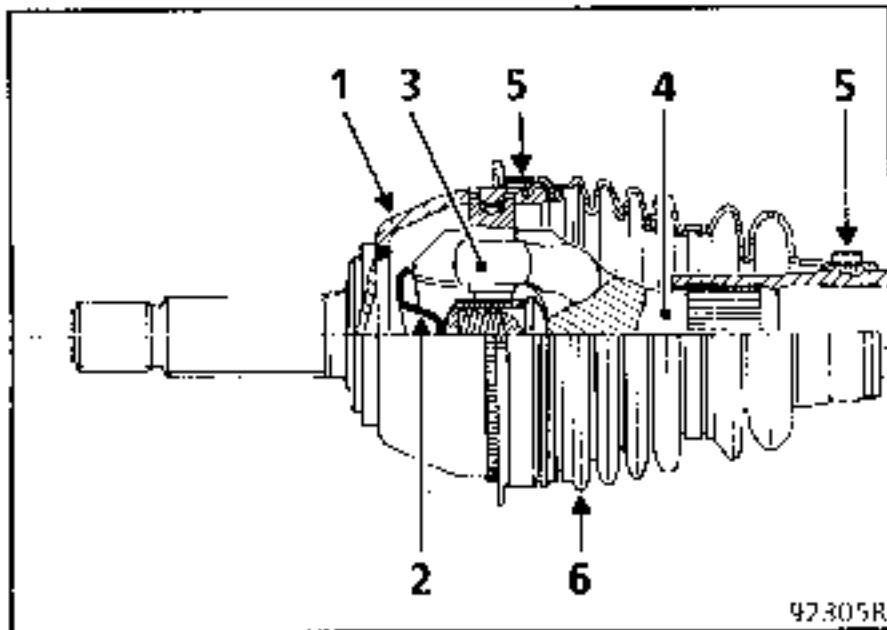

There are two types of driveshaft:
 - diameter 35 identical method
 - diameter 26 with ring diameter 35 identical method

Remove the gaiter at the gearbox end (see section "Gaiter at gearbox end").
 Unclick the small clip using tool T.Av. 1168.

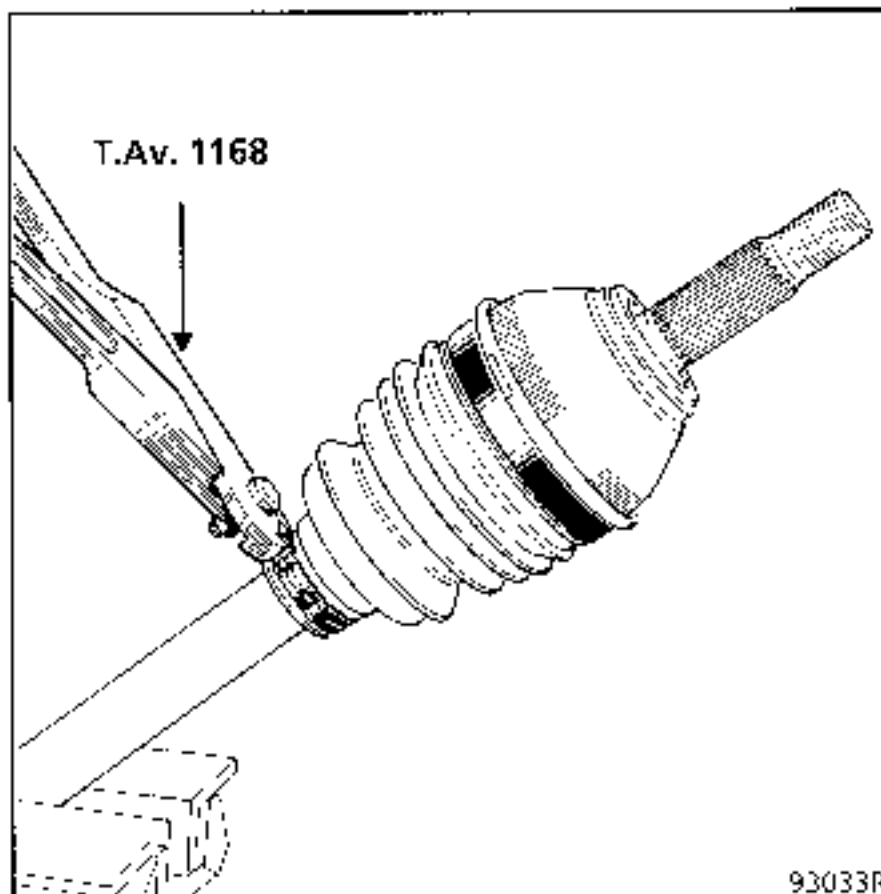

Cut the collars, taking care to avoid damaging the groove in the stub axle bowl.

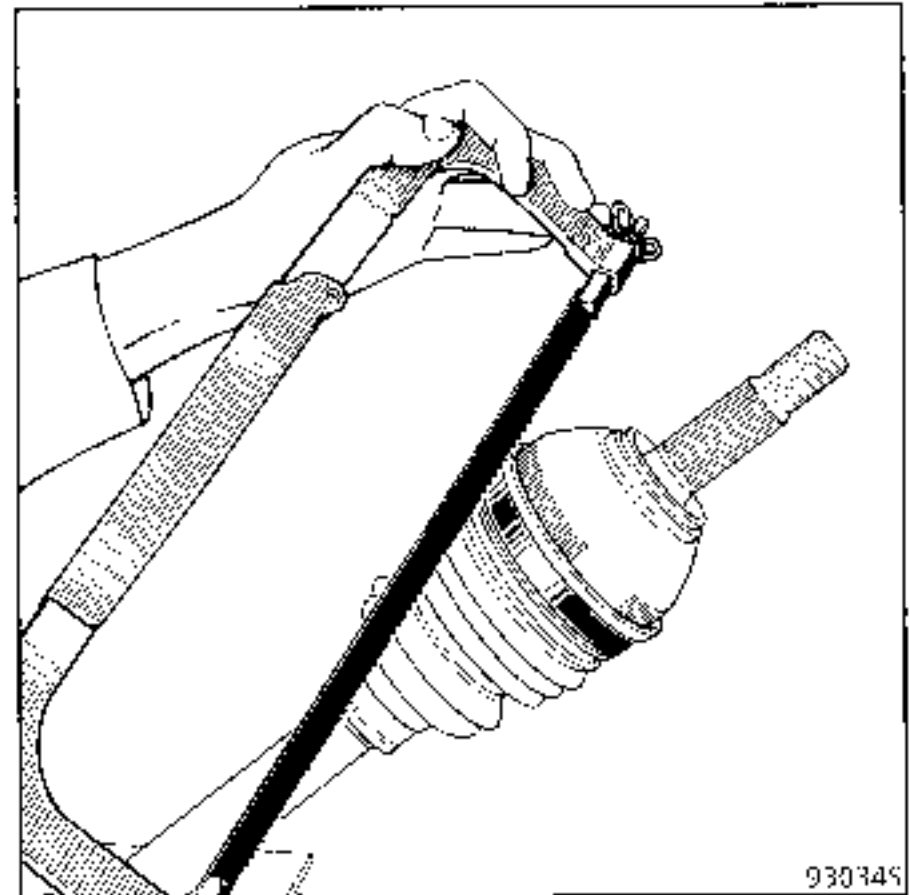

Cut the gaiter.

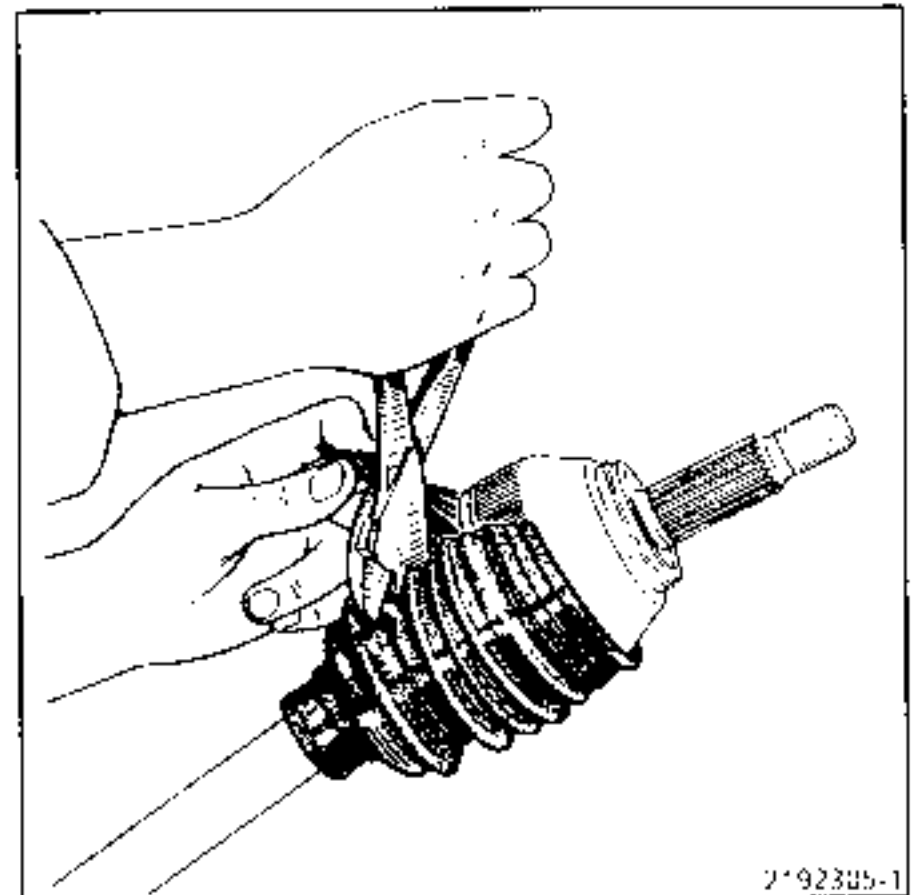

Remove as much grease as possible.

REPLACEMENT (cont)

Refitting

Spread the sachet of grease evenly between the gaiter and the stub axle bowl.

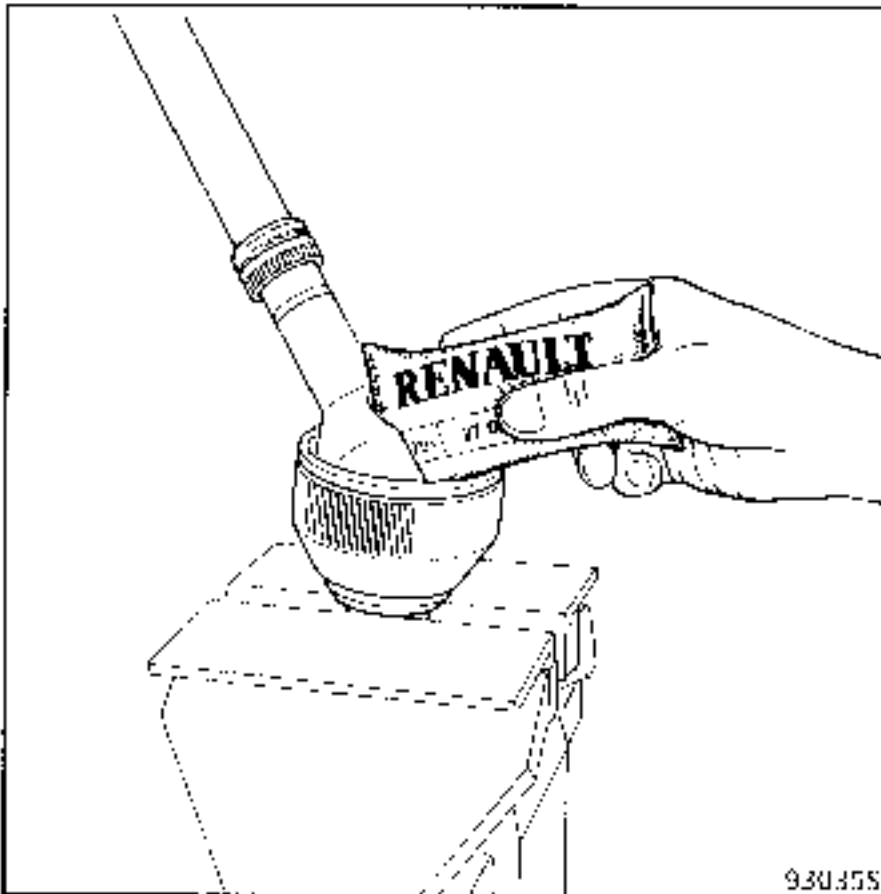

NOTE : Ensure that the amount of grease specified in the "Materials" section is used.

Fit the gaiter into position and check it "clicks" into the groove on the stub axle bowl and then on the driveshaft.

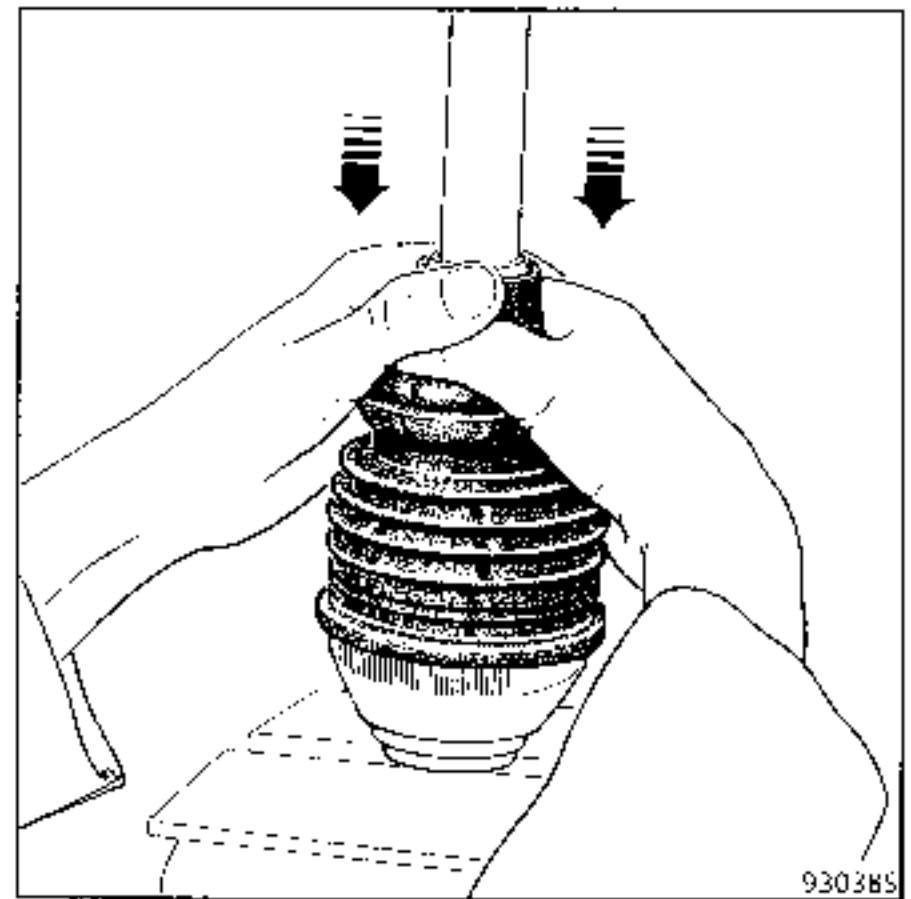
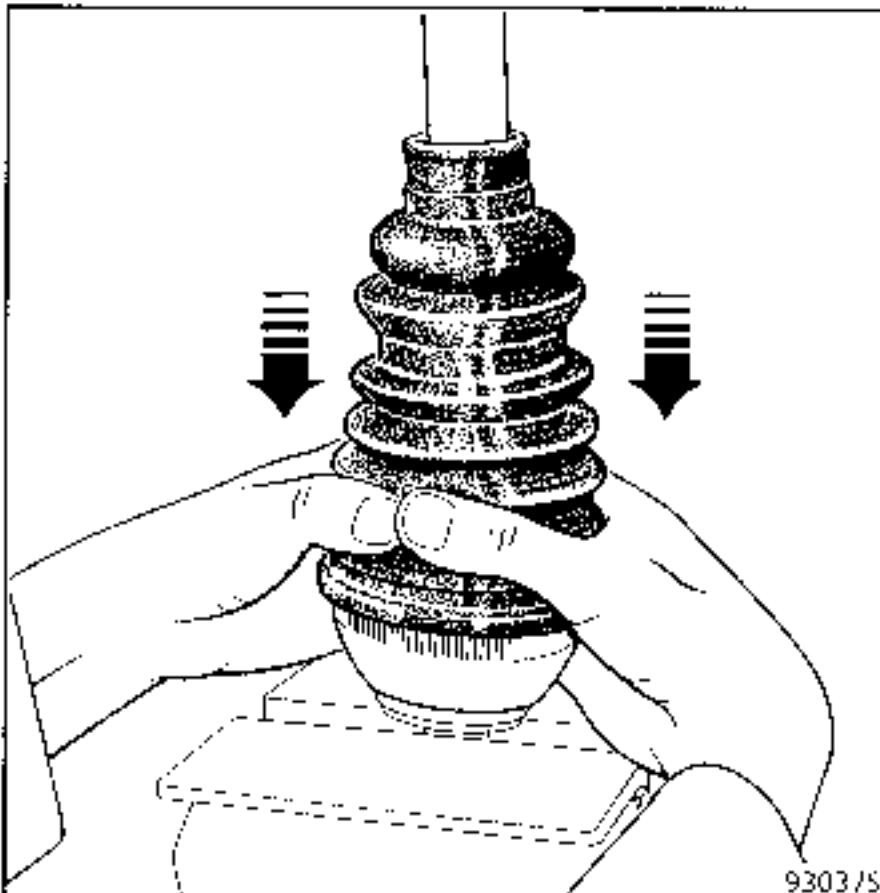

Position the gaiter shoulders when it is mounted.

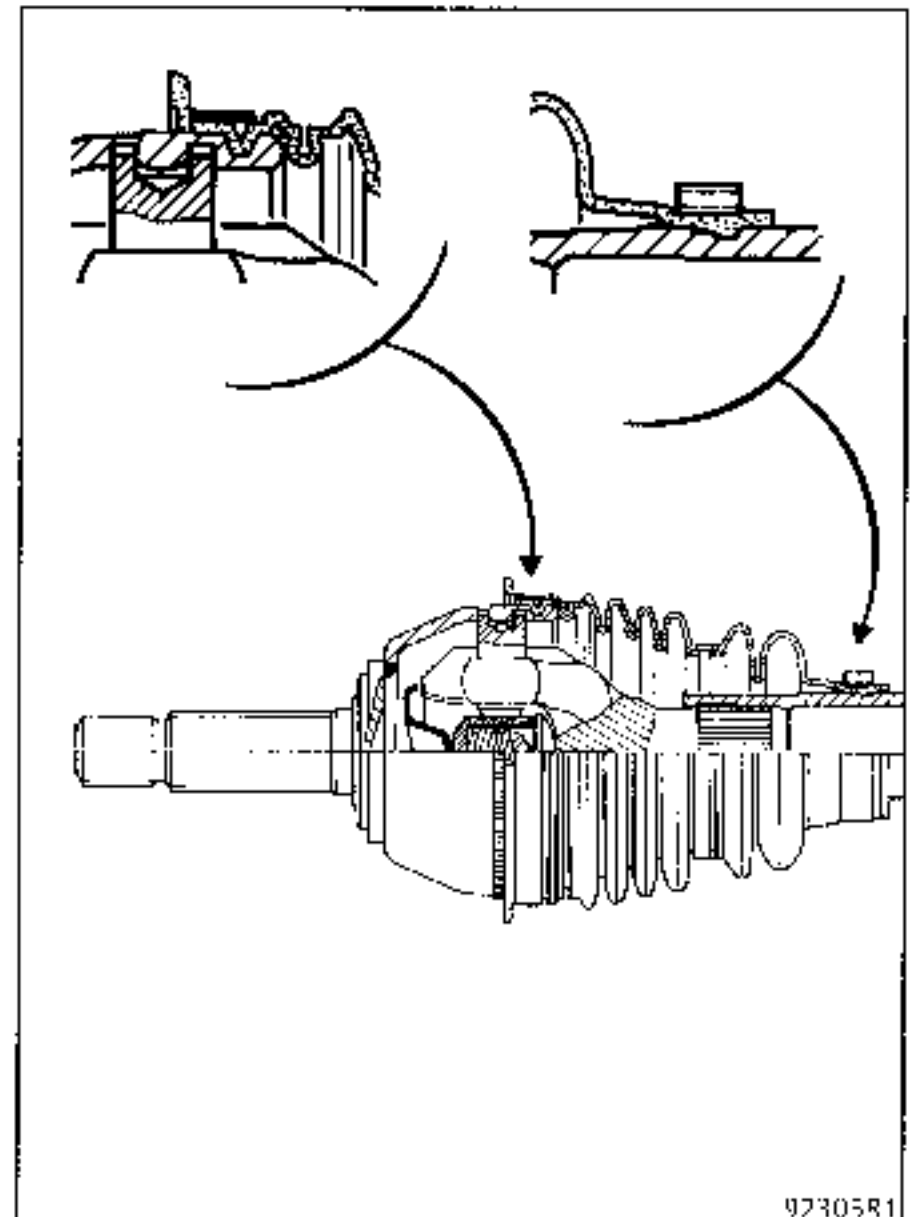

Turn the joint by hand to check the two shoulders have been correctly fitted and to ensure the correct amount of air is in the joint.

Refitting (cont)

Fit the clips and tighten them using tool
T.Av. 1168.

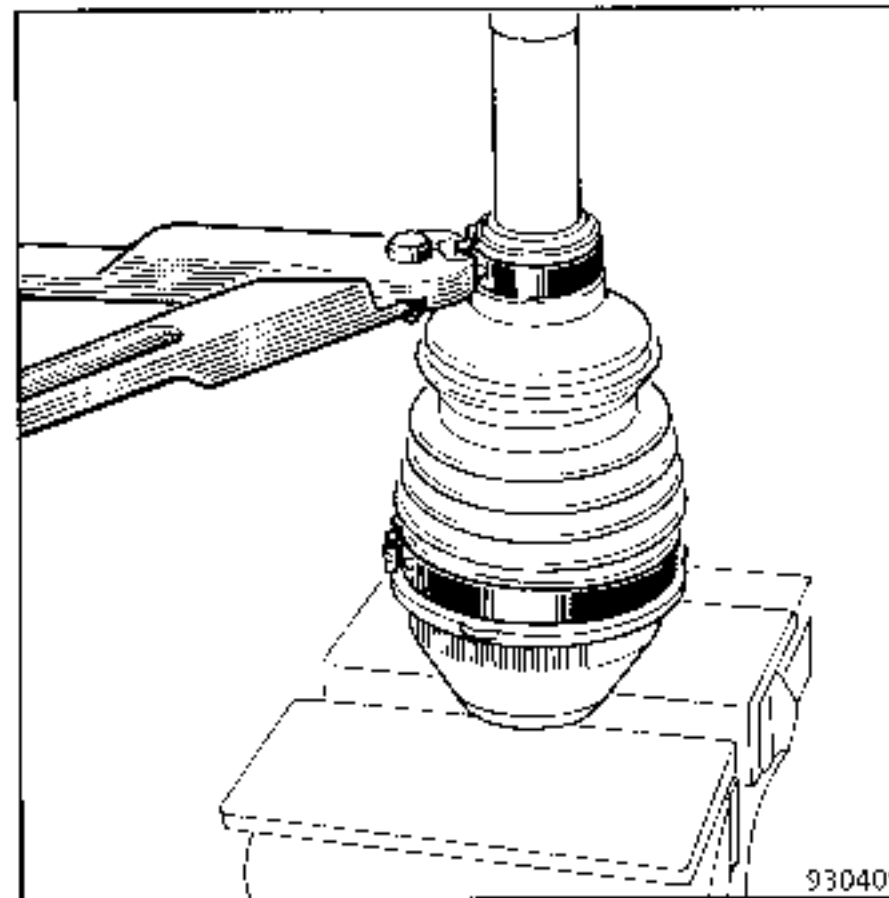
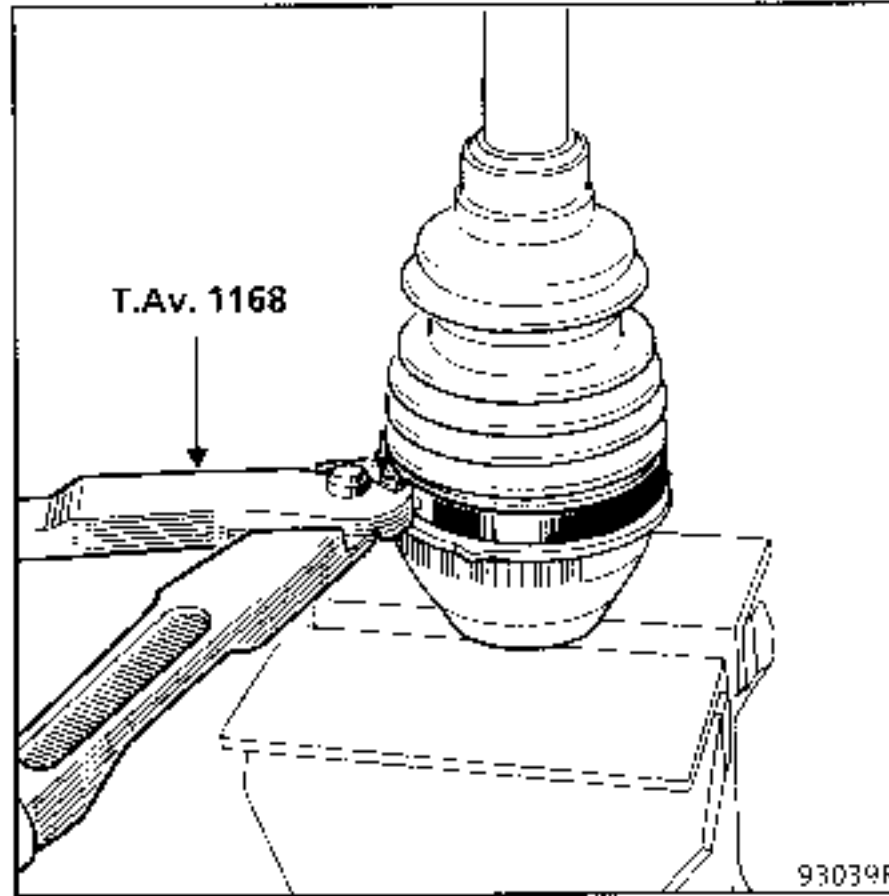

NOTE : do not re-use the small diameter clip.

Refit the gaiter at the gearbox end.

The **OETIKER T.Av. 1256** pliers for driveshaft gaiter clips may also be used for **GE** thermoplastic driveshaft gaiters.

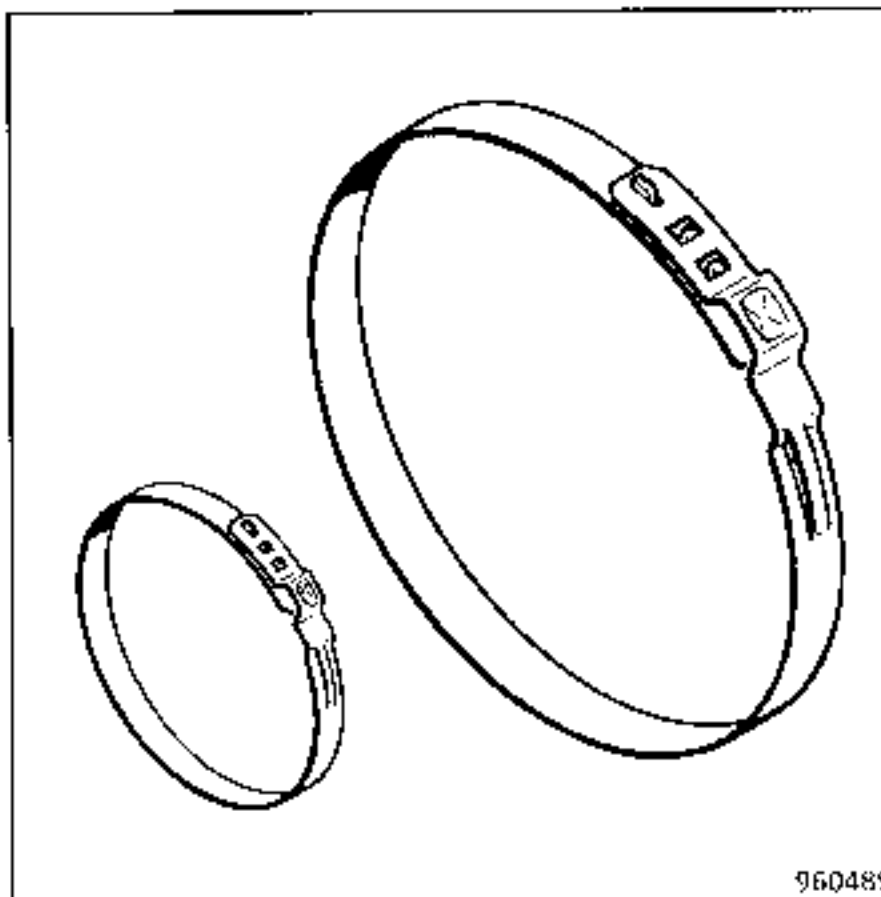

POSITION 1 - Pre-crimping and positioning the clip

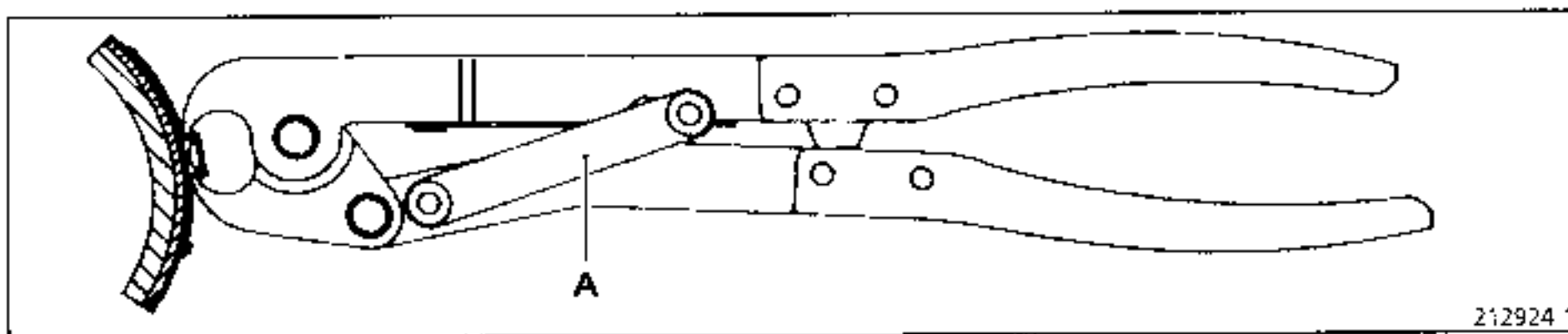

Position bar (A) in the lower notch and close the pliers as far as possible. The pre-crimped clip slides onto the gaiter and may then be positioned.

POSITION 2 - Crimping

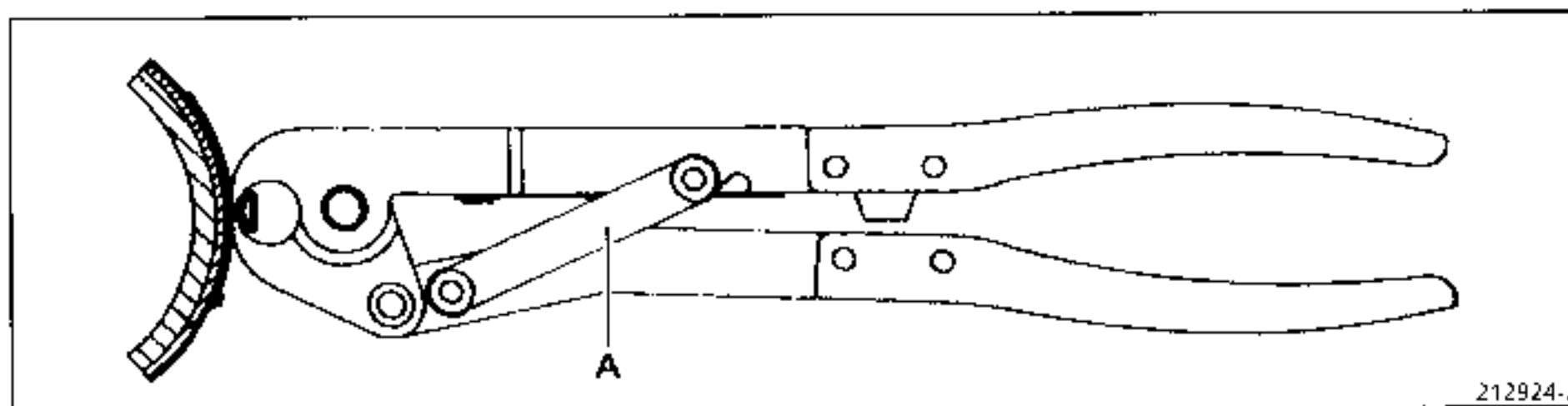

Position bar (A) in the upper notch and close the pliers as far as possible.

REPLACEMENT

A 6 ball joint may be fitted at the wheel end on these drive shafts. There are two types:

- **1st assembly** - can be dismantled (locking ring 7 may be reached),

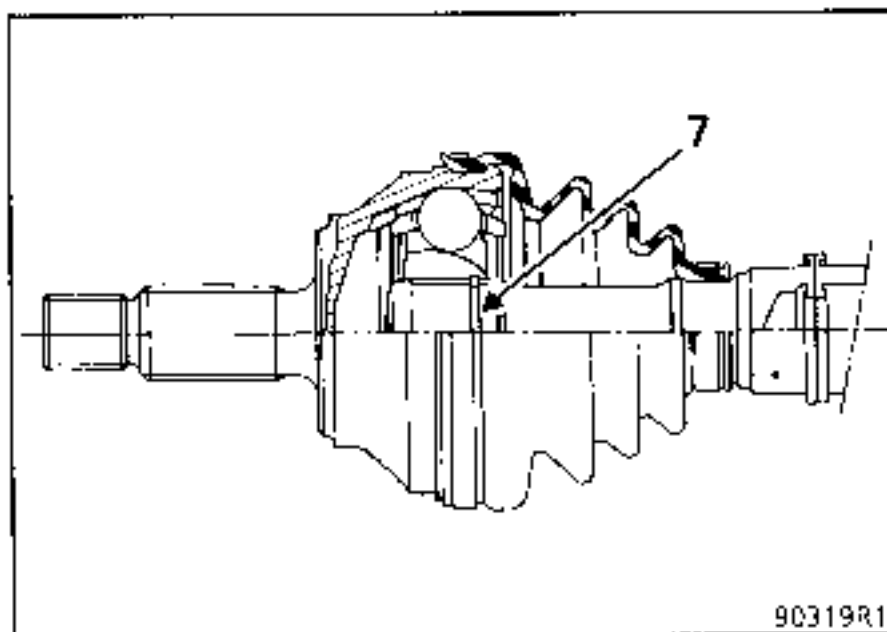

- **2nd assembly** - cannot be dismantled (driveshaft shaft 2 is bonded and locking ring 7 is inaccessible).

Slide the gaiter on and ensure it clicks into the grooves on the stub axle bowl and on the driveshaft.

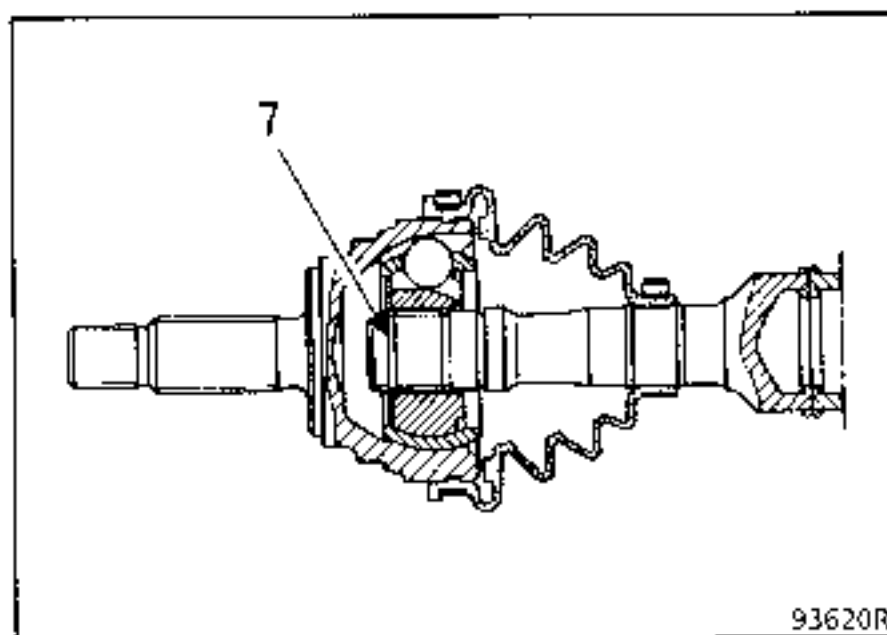

The joint at the gearbox end must be removed to replace the gaiter.

Repairing 1st assembly

6-BALL JOINT AT WHEEL END

- 1 Stub axle bowl
- 2 Driveshaft
- 3 Rubber or thermoplastic gaiter
- 4 Balls
- 5 Ball hub
- 6 Ball cage
- 7 Locking ring

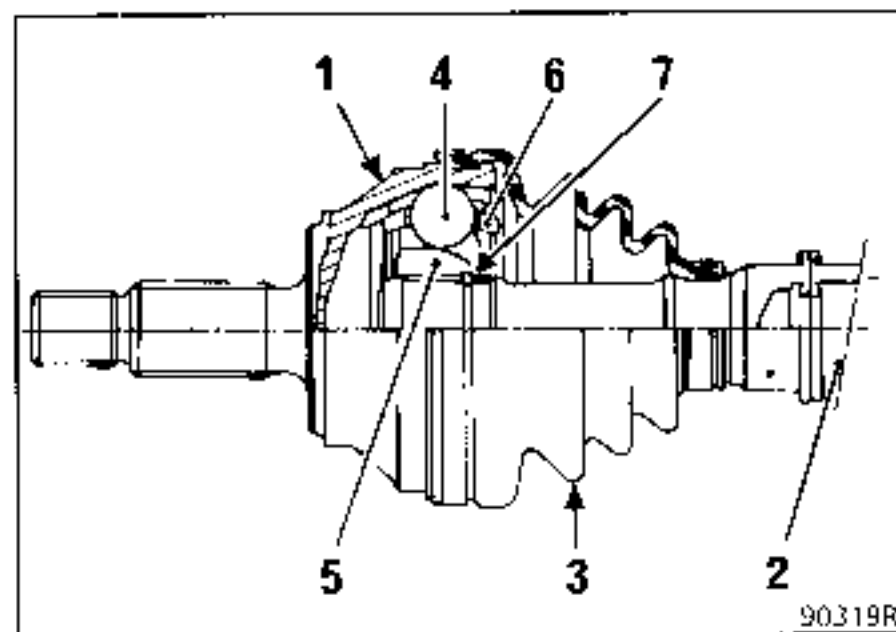

REMOVAL

Cut the clip and the gaiter along its length.

Remove as much grease as possible.

Spread the locking ring (7) and at the same time tap the exposed face of the ball hub (5) with a mallet.

Separate the joint from the shaft.

REPLACEMENT (cont)

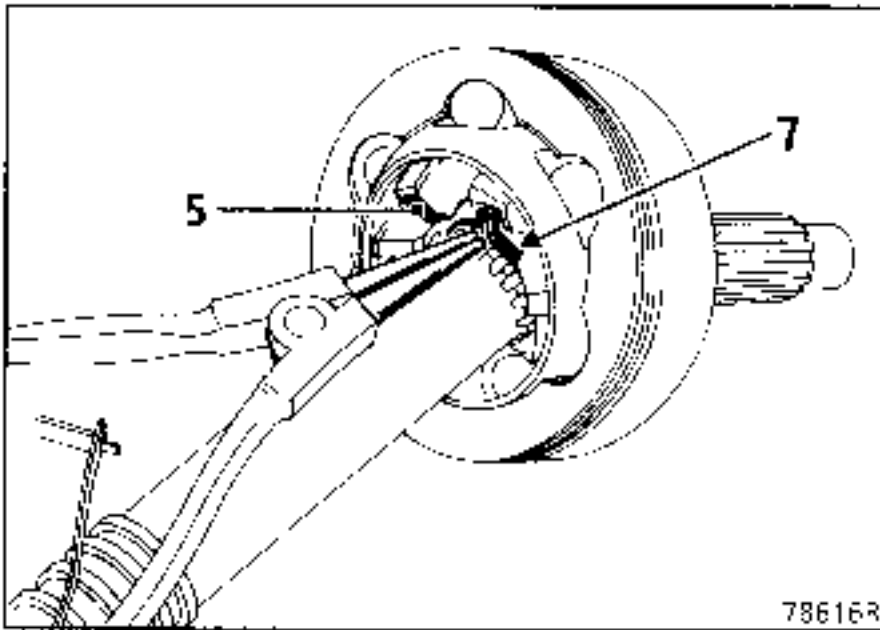

REFITTING

Fit to the shaft:

- the rubber clip (A),
- the gaiter (3).

Slide the ball joint (1) complete with the locking ring onto the shaft splines until the locking ring locates in shaft groove (B).

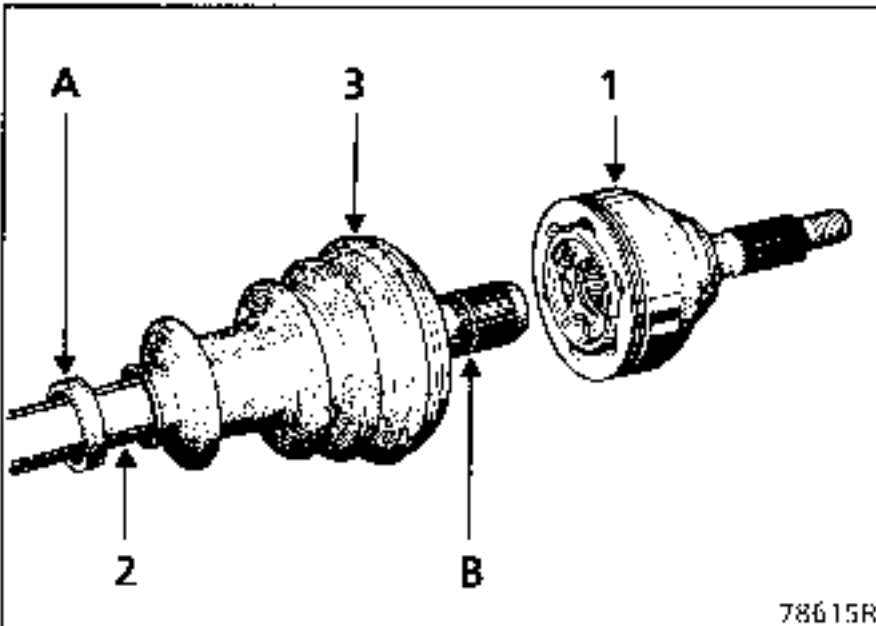

Spread the sachet of grease evenly between the gaiter and the stub axle bowl.

NOTE : Ensure that the amount of grease specified in the "Materials" section is used.

Position the gaiter lips in their grooves on the stub axle bowl (1) and the driveshaft (2).

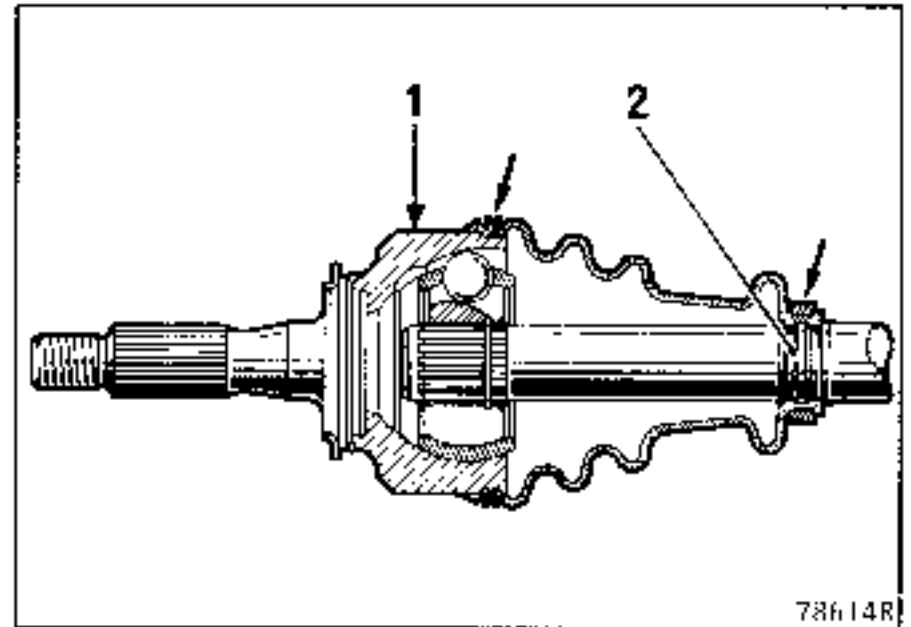

Fit the retaining clips on the gaiter using the two locally made rods (see diagram).

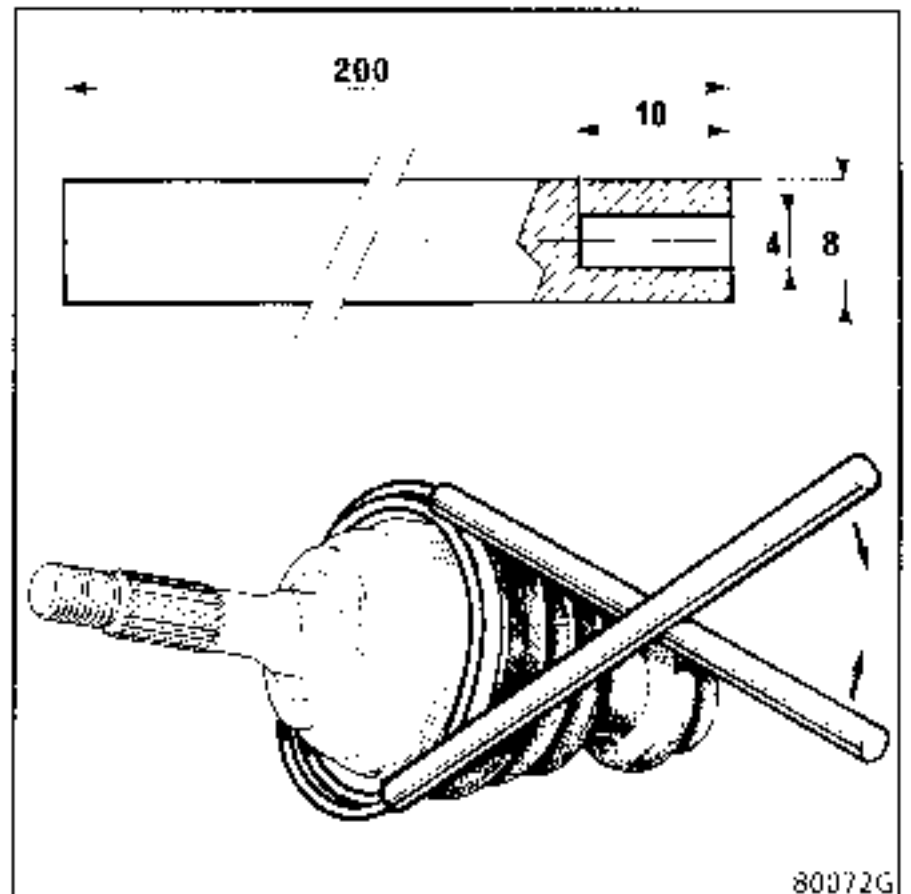

REPLACEMENT

- 1 Stub axle bowl
- 2 Driveshaft
- 3 Rubber gaiter
- 4 Balls
- 5 Ball hub
- 6 Ball cage
- 7 Locking ring

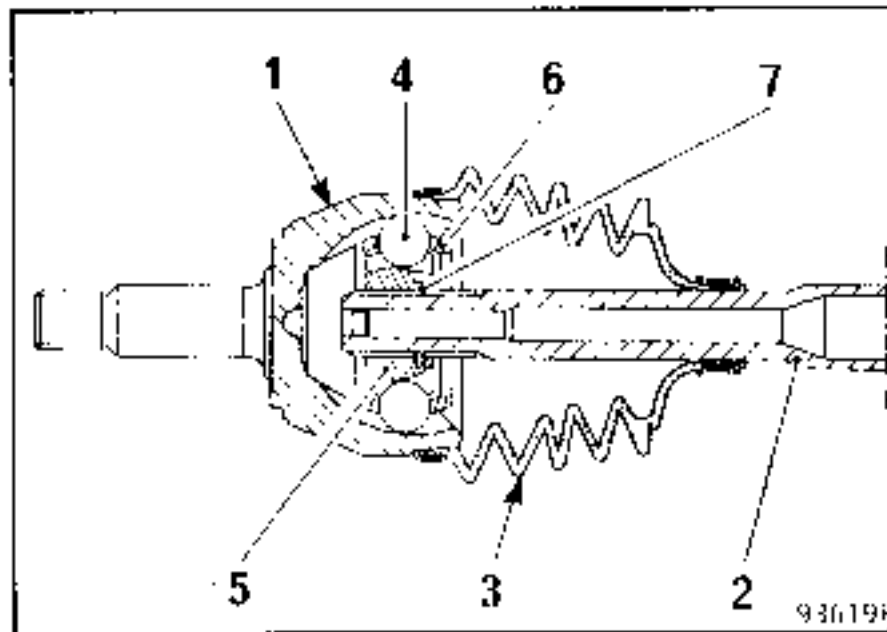

This joint cannot be dismantled as the shaft (2) is too tightly fitted into the ball hub (5).

If the gaiter breaks, the driveshaft must be replaced, since it is impossible to expand the gaiter to pass it over the gearbox end.

REPLACEMENT

SPECIAL TOOLING REQUIRED		
T.Av.	1034	Pliers for OETIKER driveshaft clips

- 1 Yoke
- 2 Spider
- 3 Heat shield or metal retaining cover
- 4 Rubber gaiter
- 5 Retaining clip
- 6 Driveshaft
- 7 Metal insert

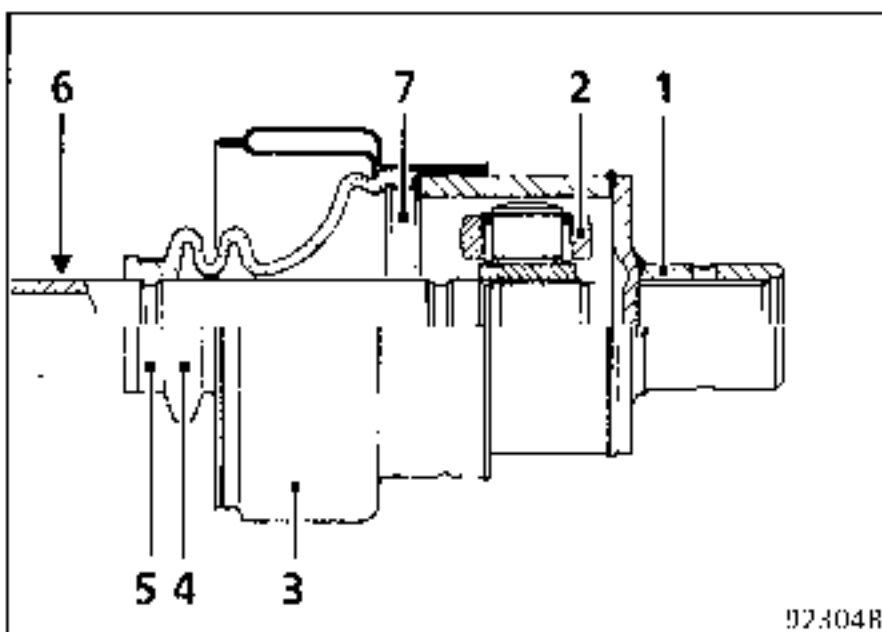
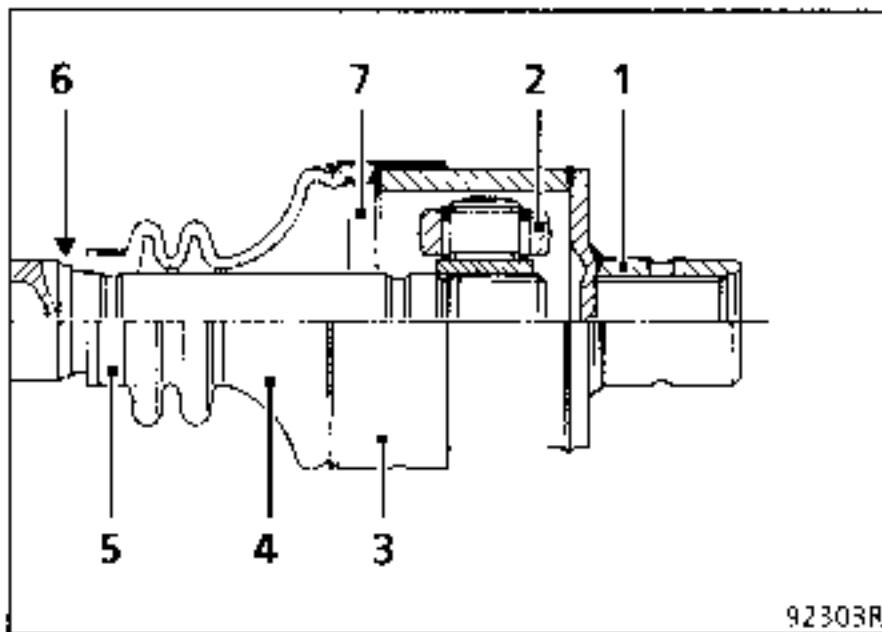

REMOVAL

Uncrimp the three points securing the cover using pliers.

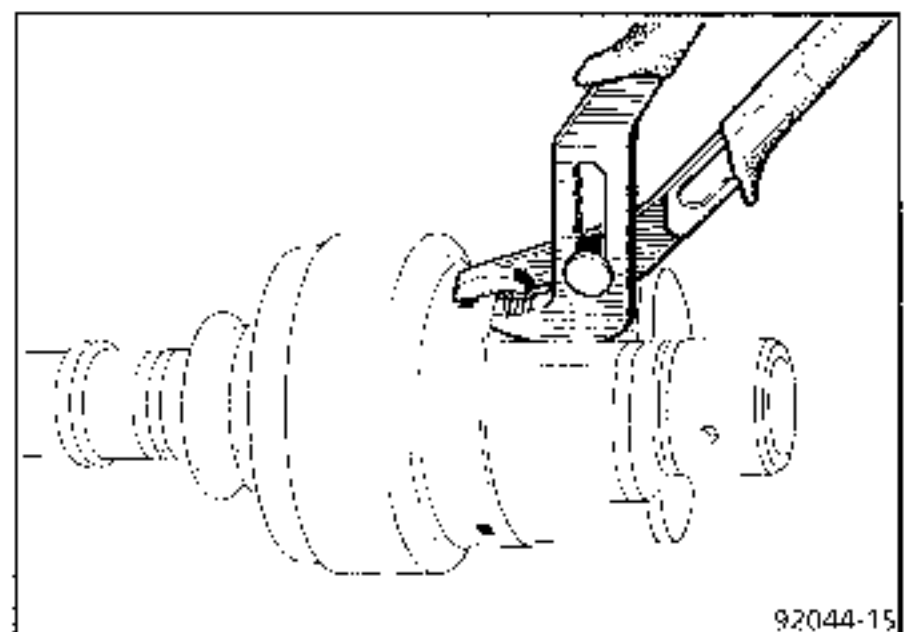
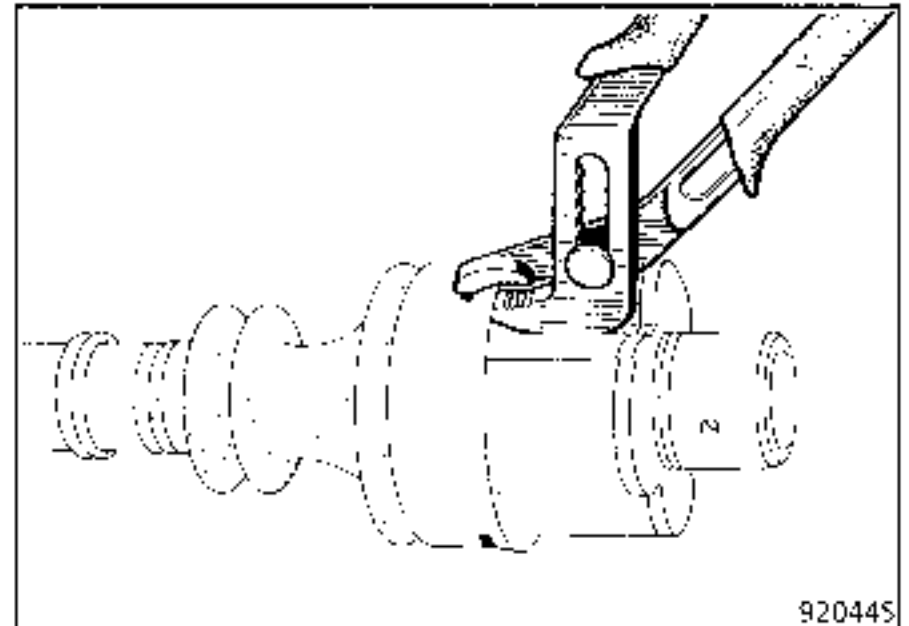

REPLACEMENT (cont)

Cut the retaining clip and the gaiter along its length.

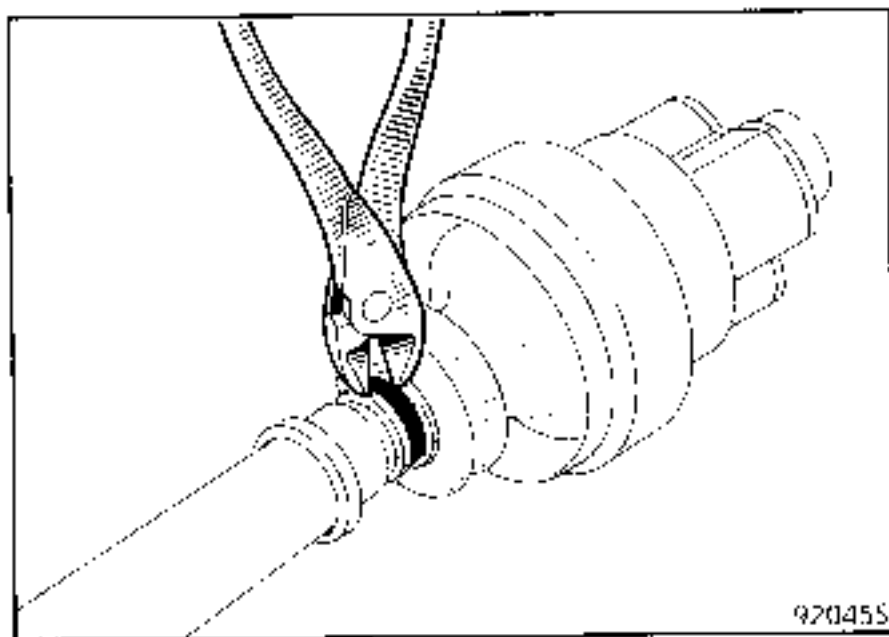

Remove as much grease as possible.

Remove the heat shield or the metal retaining cover (depending on assembly).

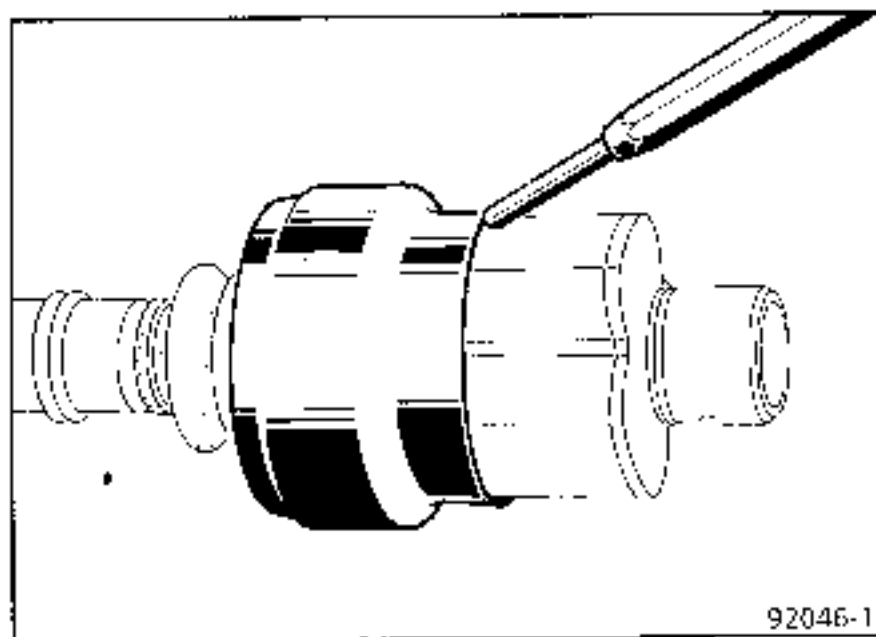
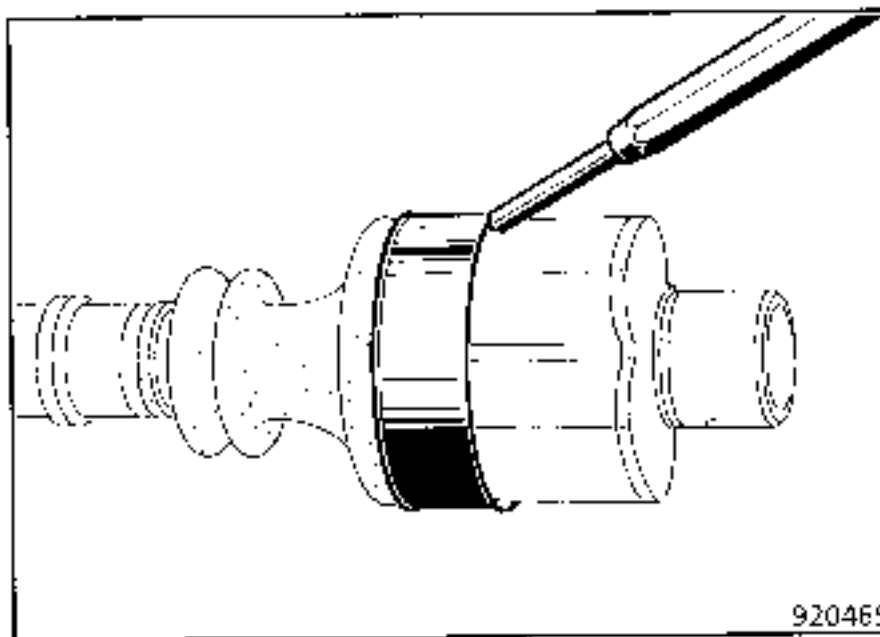

Remove the yoke.

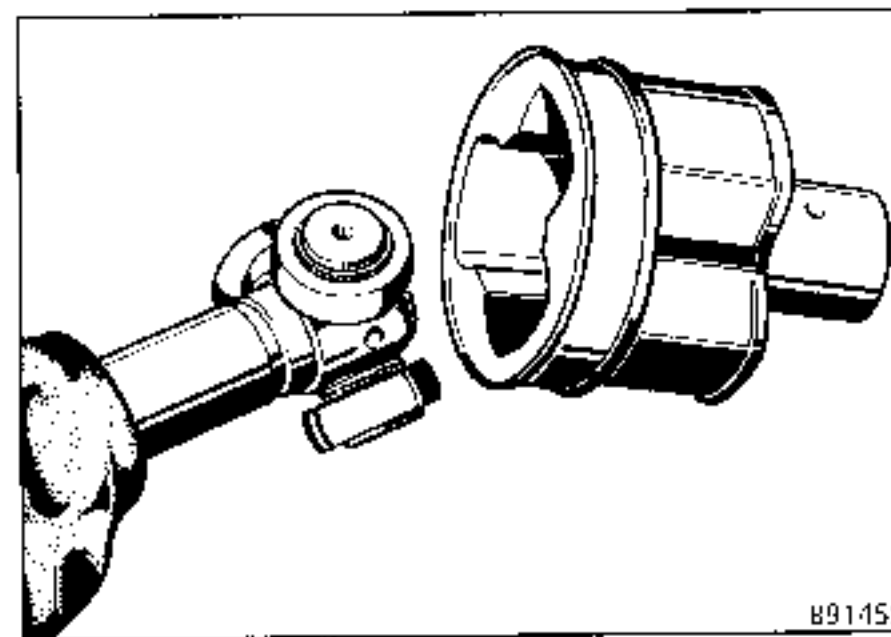
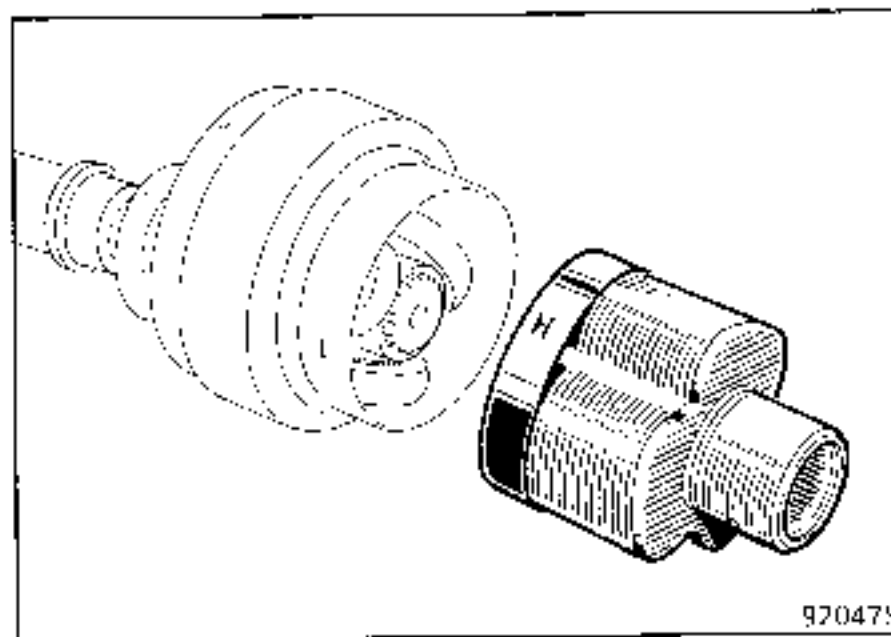

NOTE : the yoke is not fitted with a locking plate so it may be removed without force.

Do not remove the roller cages from their respective trunnions since the cages and rollers are matched and must never be mixed.

Never use thinners to clean the component parts.

REPLACEMENT (cont)

Remove the circlip (depending on model).

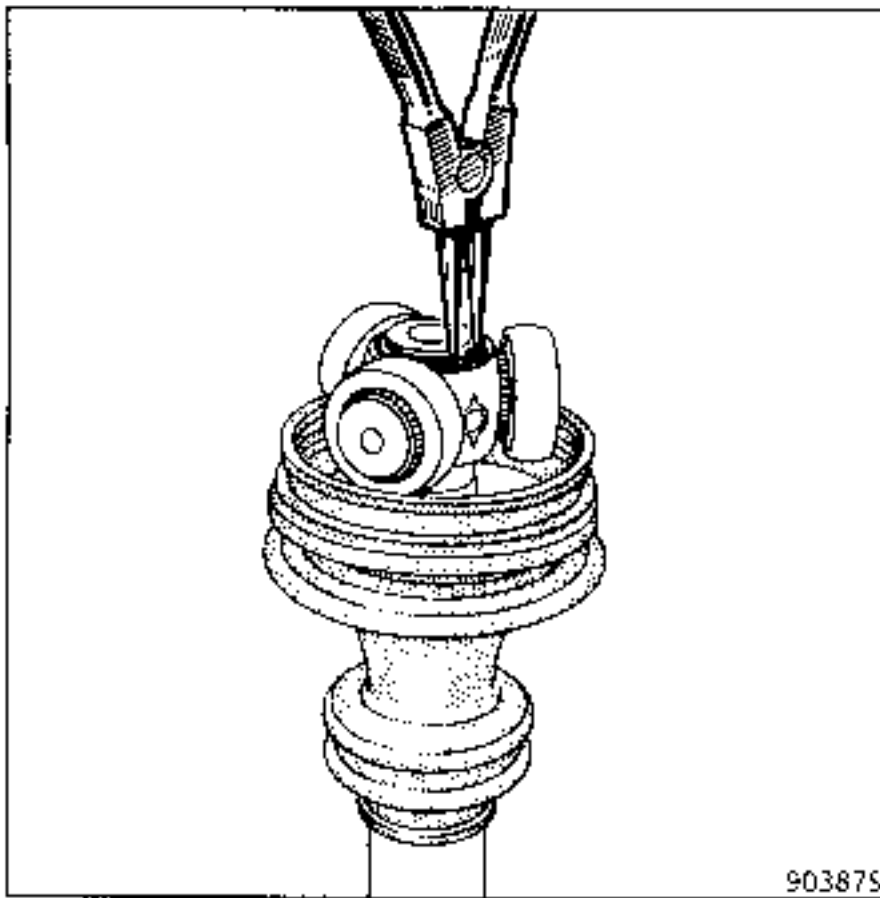

On the press, remove the spider, using a gripping extractor of type **FACOM U53G** for support.

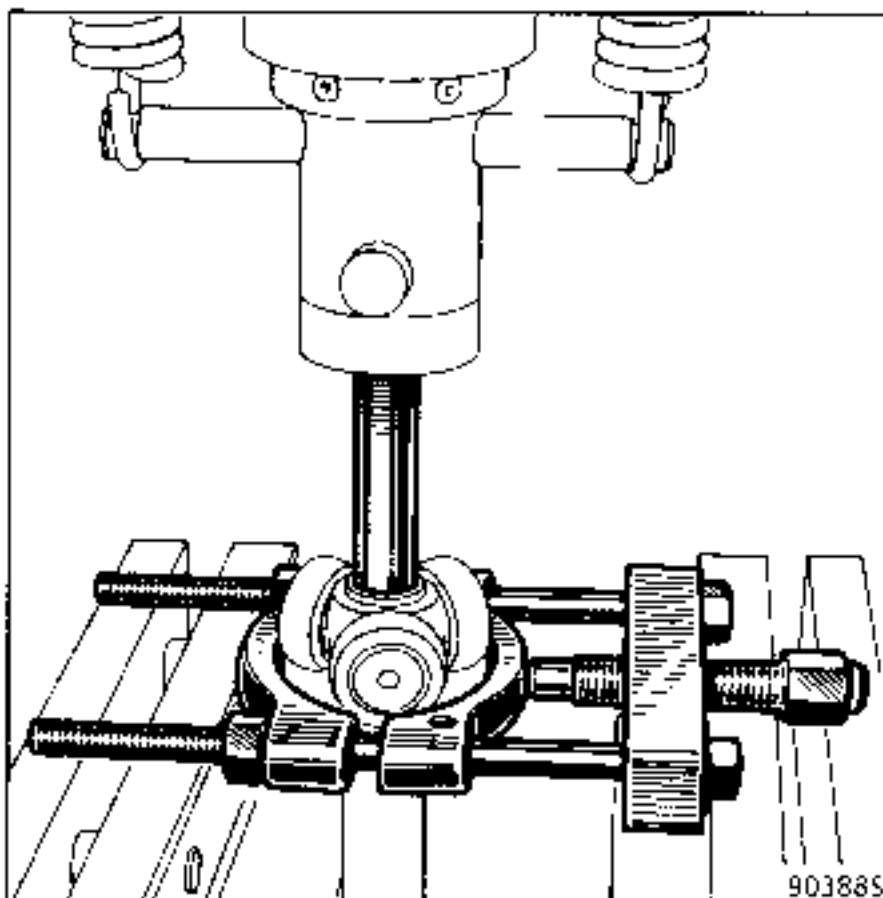
**REFITTING**

Lubricate the driveshaft and slide on:

- a new retaining clip,
- the rubber gaiter (4) with metal insert (7) and the heat shield or metal retaining cover (3) (depending on assembly).

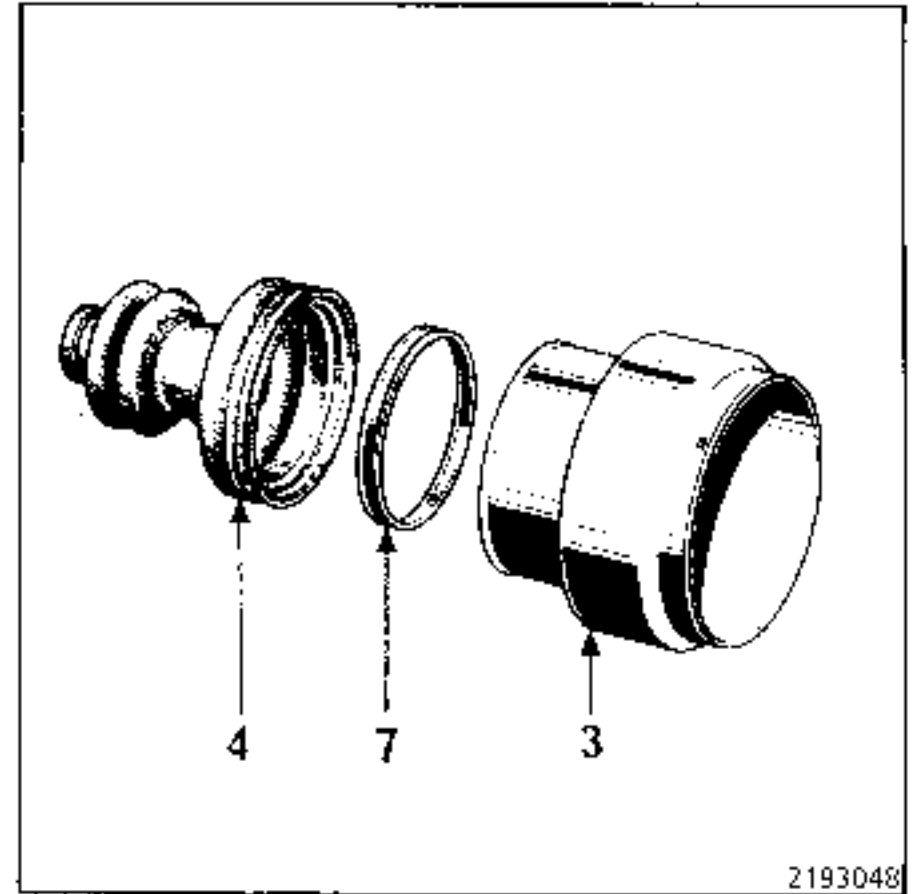

Fit the spider onto the splined shaft.

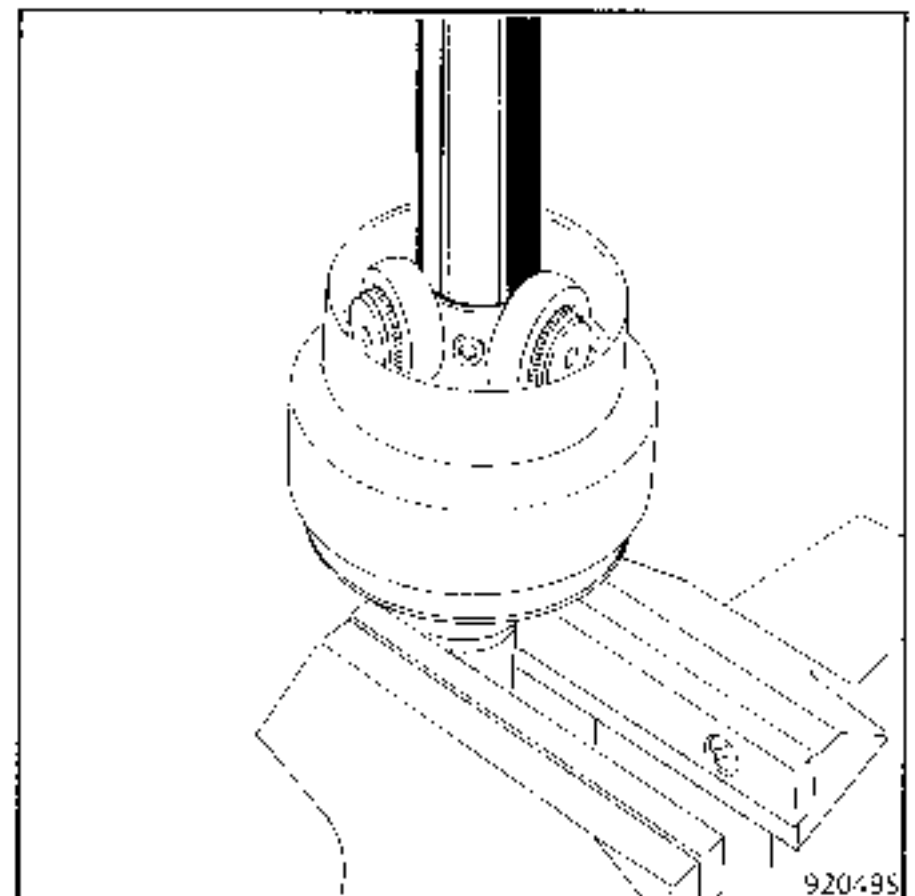

REPLACEMENT (cont)

Refit the retaining clip or make three crimping points 120° apart, pushing back the metal on the driveshaft splines.

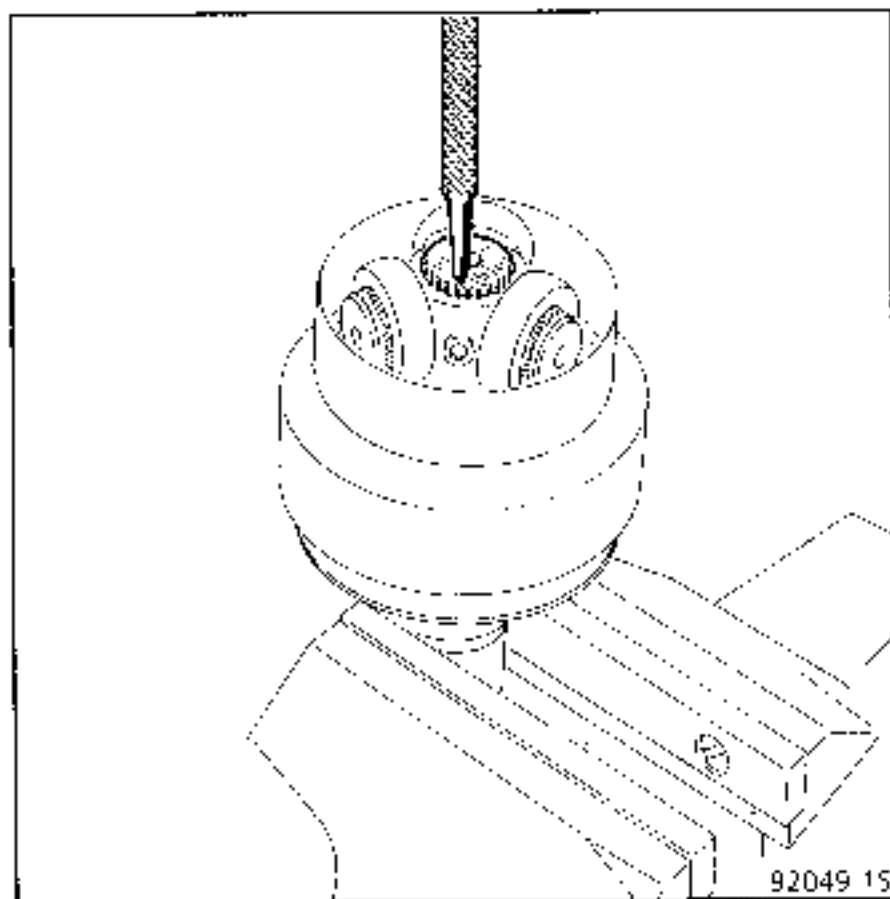

Lubricate the yoke and engage it onto the spider assembly.

Spread the sachet of grease evenly between the gaiter and the yoke.

NOTE : Ensure that the amount of grease specified in the "Materials" section is used.

Position:

- the gaiter and its metal insert in the heat shield or retaining cover,
- the heat shield or retaining cover by sliding it on until the guide plate is flush with the yoke.

In this position, make three crimping points in the locations provided for this purpose on the guide plate.

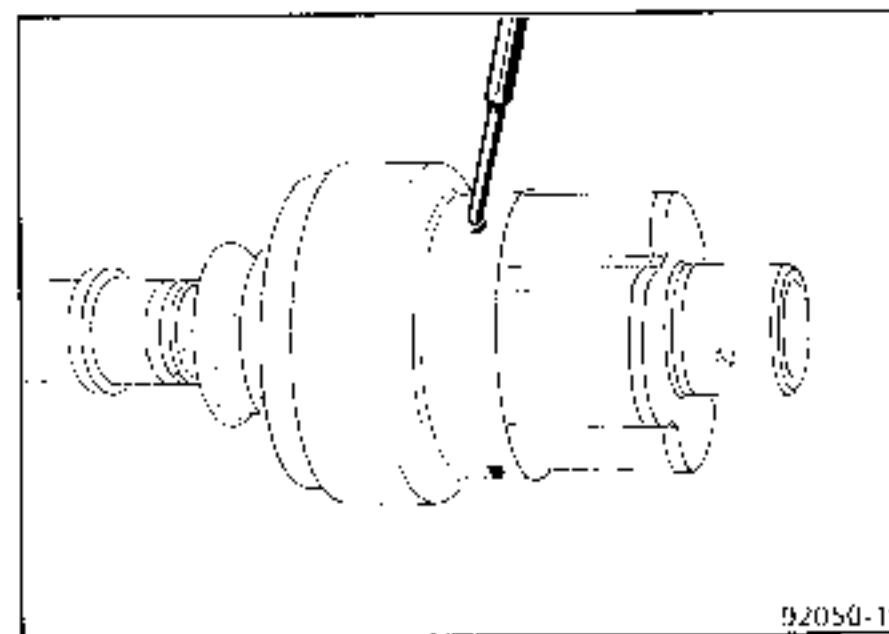
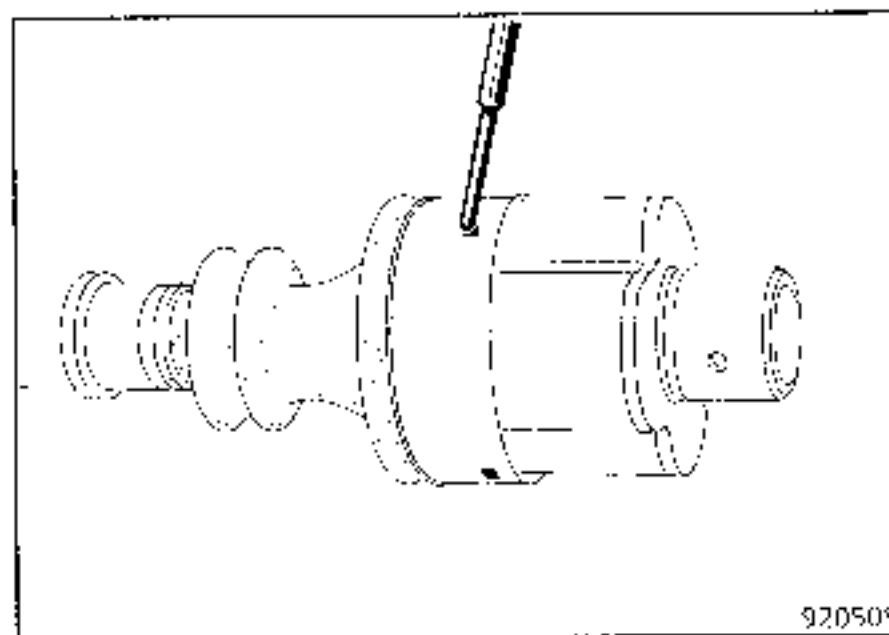

Insert a smooth, rounded end rod between the gaiter and the shaft to correct the amount of air inside the joint.

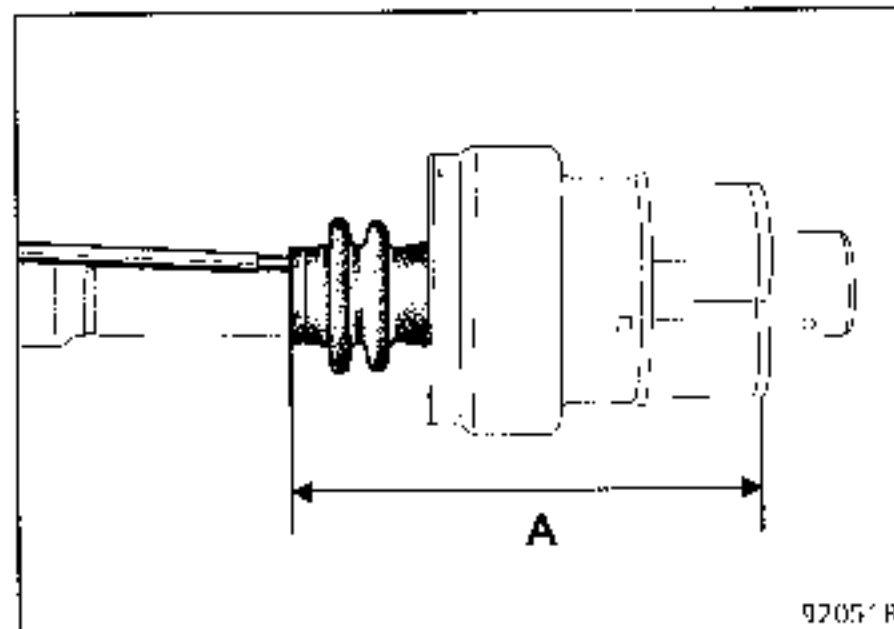

Expand or shorten the joint until dimension **A** = 156 ± 1 mm is obtained (dimension measured between the end of the gaiter and the largest diameter machined face of the yoke).

REPLACEMENT (cont)

In this position remove the rod.

Fit the clip to the gaiter and tighten it using tool
T.Av. 1034.

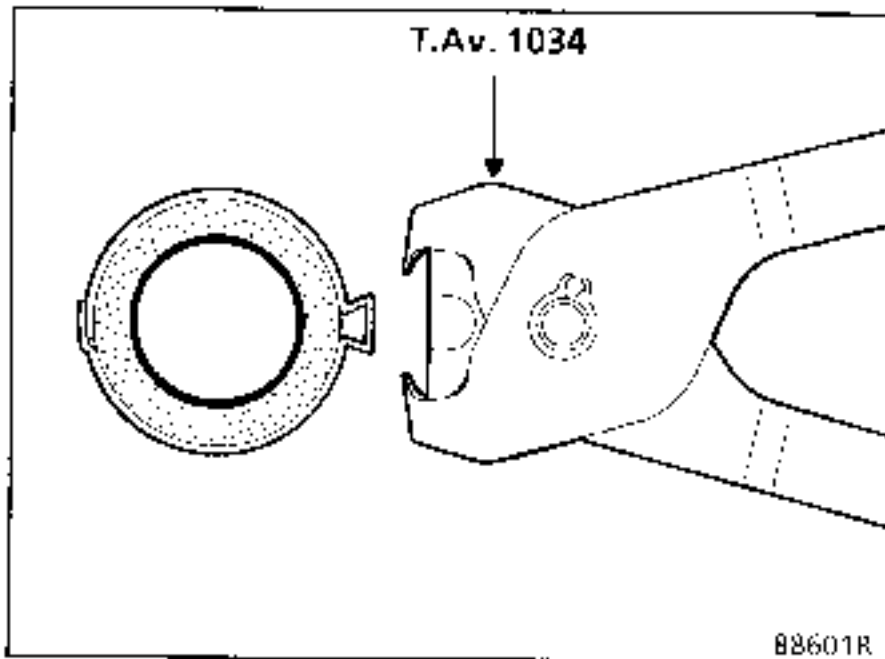
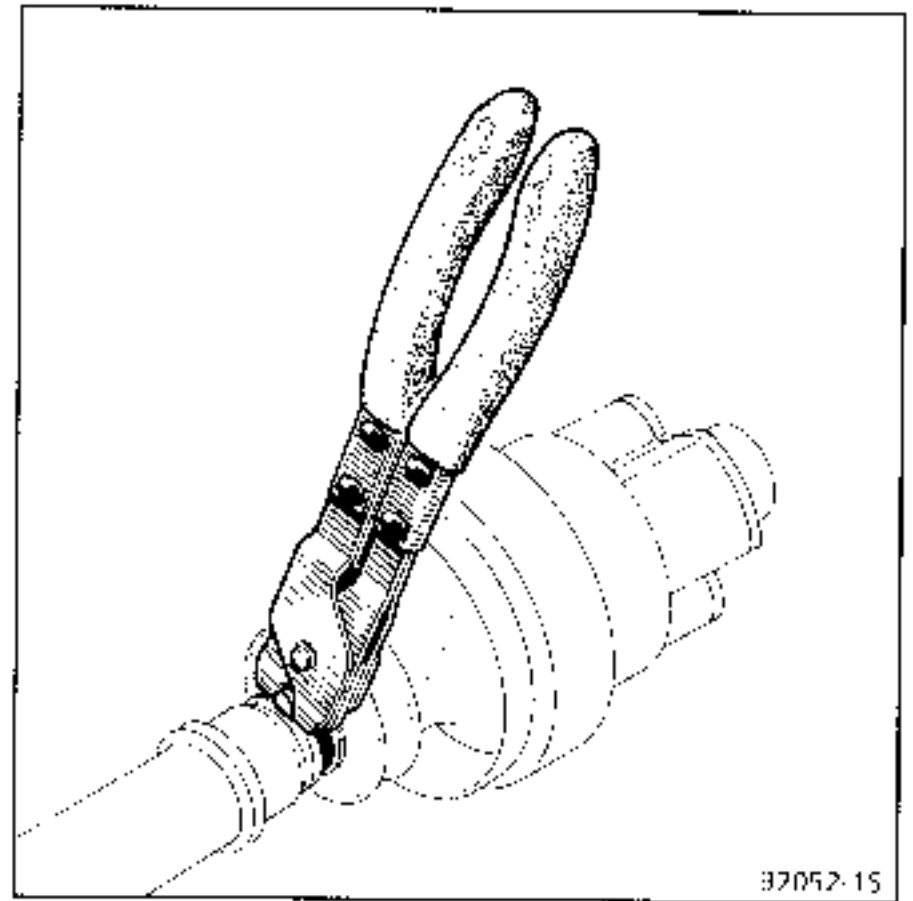
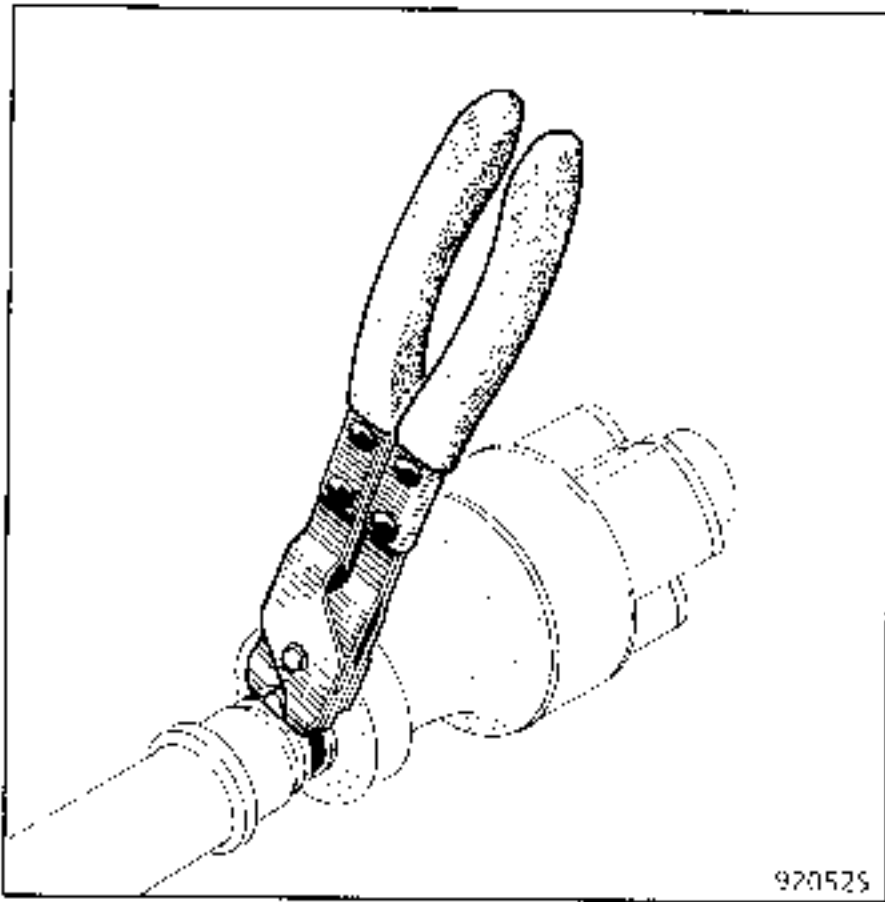

REPLACEMENT

- 1 Yoke
- 2 Spider
- 3 Metal cover
- 4 Retaining spring
- 5 Rubber gaiter
- 6 Retaining ring
- 7 Driveshaft

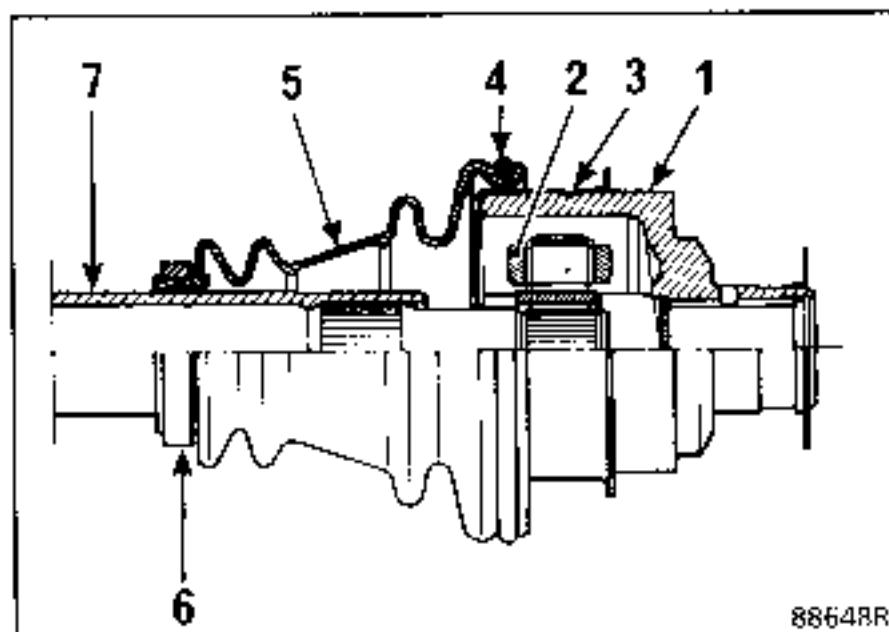
**REMOVAL**

Release the spring (4) which retains the gaiter on the yoke (1).

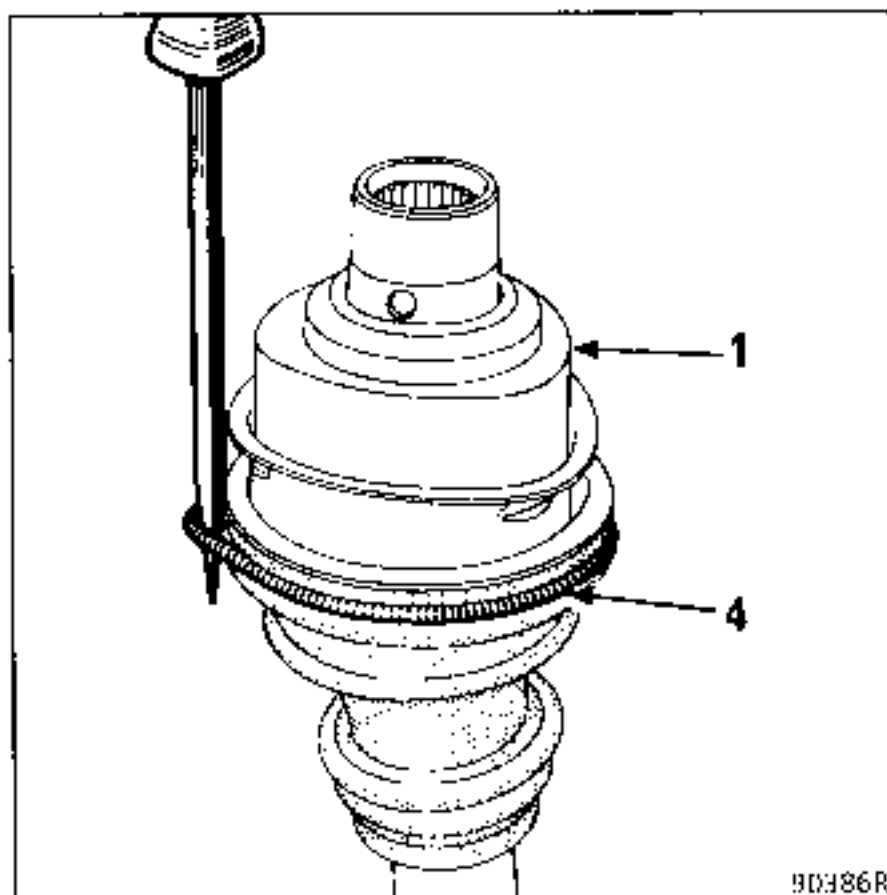

Cut the gaiter along its length. Remove as much grease as possible.

Using a pair of pliers, raise each end of the anti-separation plate (C), then remove the yoke.

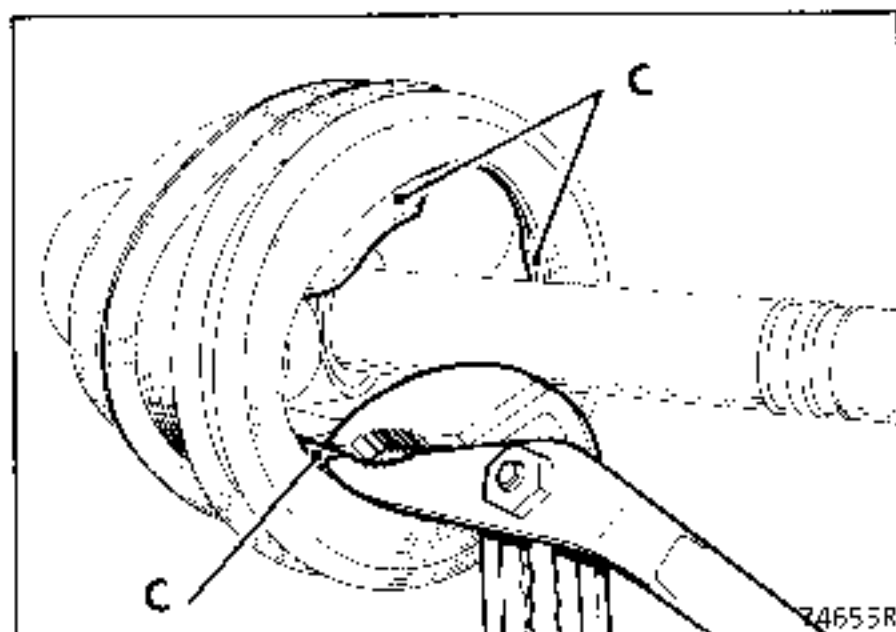

Do not remove the roller cages from their respective trunnions since the cages and rollers are matched and must never be mixed.

Never use thinners to clean the component parts.

Depending on assembly, remove the circlip.

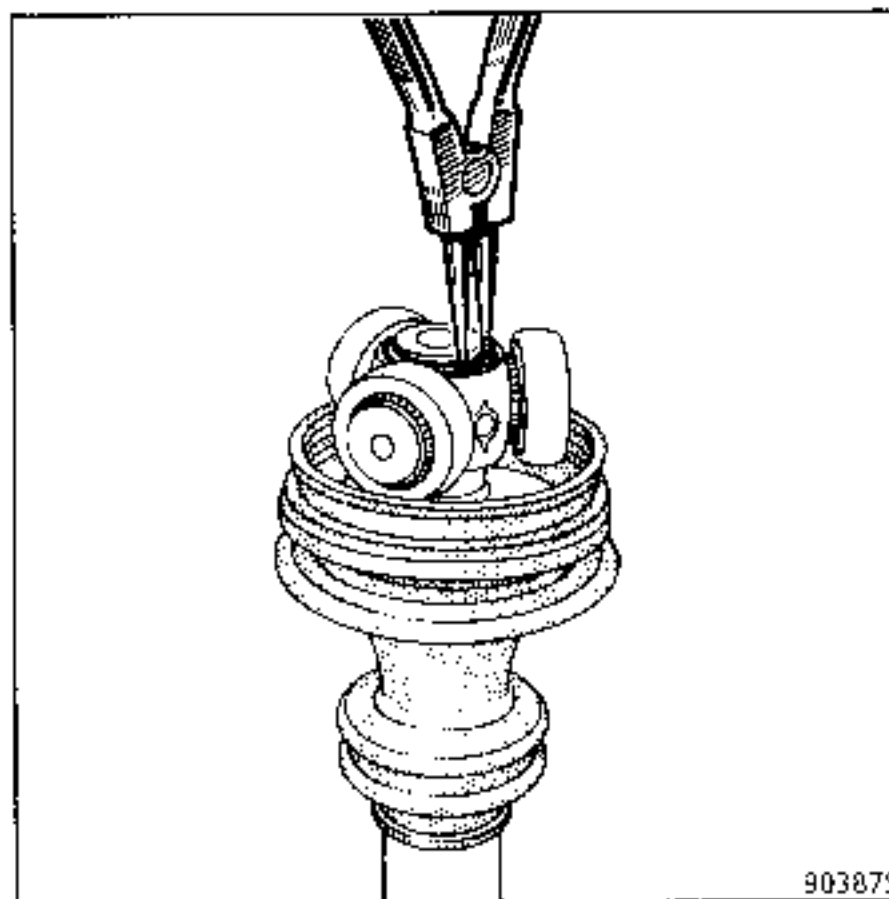

REPLACEMENT (cont)

On the press, remove the spider, using a gripping extractor for support.

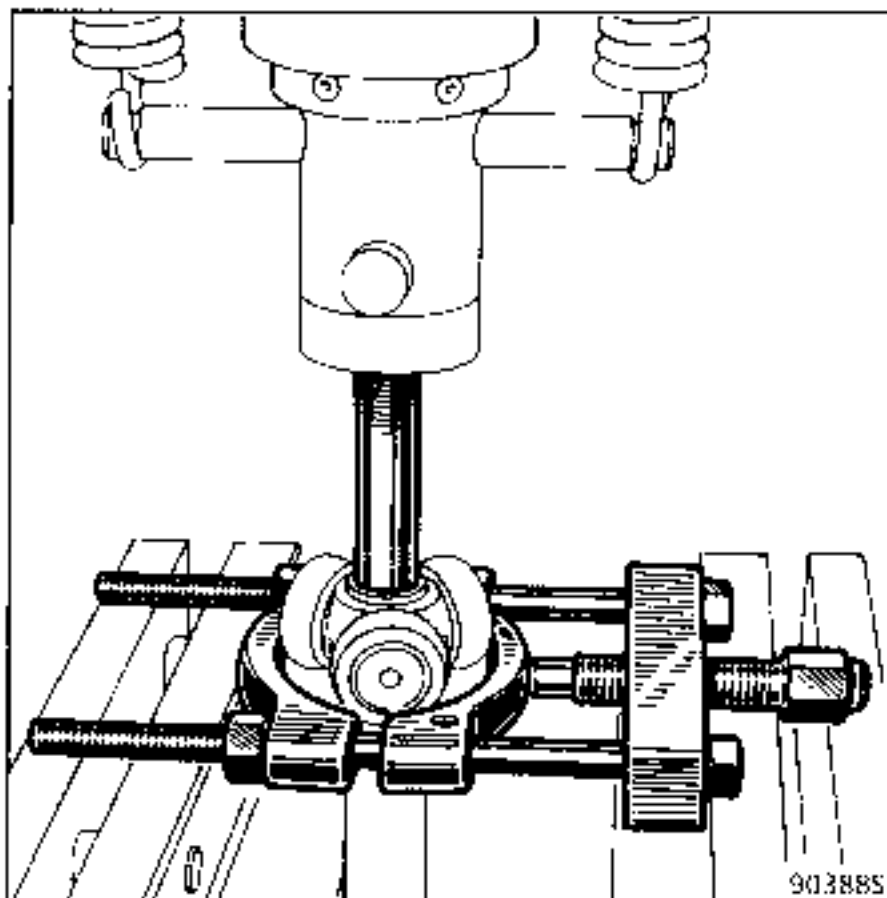
**REFITTING**

Lubricate the driveshaft and slide on the new retaining ring and gaiter.

Fit the spider onto the splined shaft.

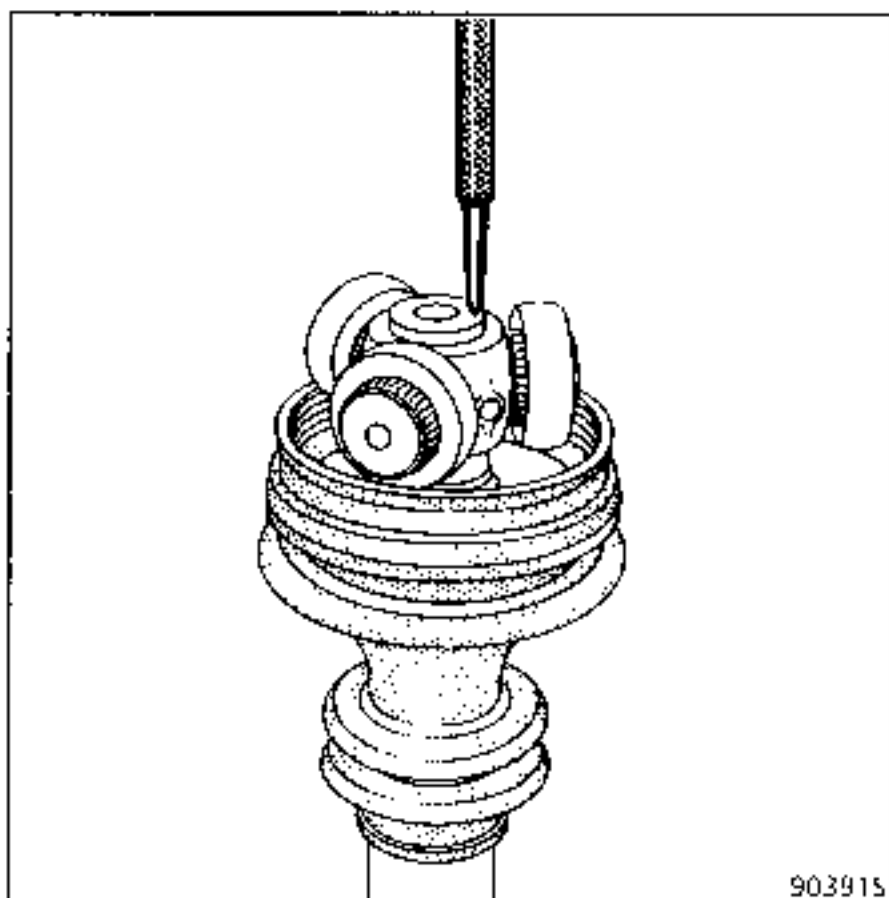

Refit the retaining clip or make three crimping points 120° apart, pushing back the metal on the driveshaft splines.

Spread the sachet of grease evenly between the gaiter and the yoke.

NOTE : Ensure that the amount of grease specified in the "Materials" section is used.

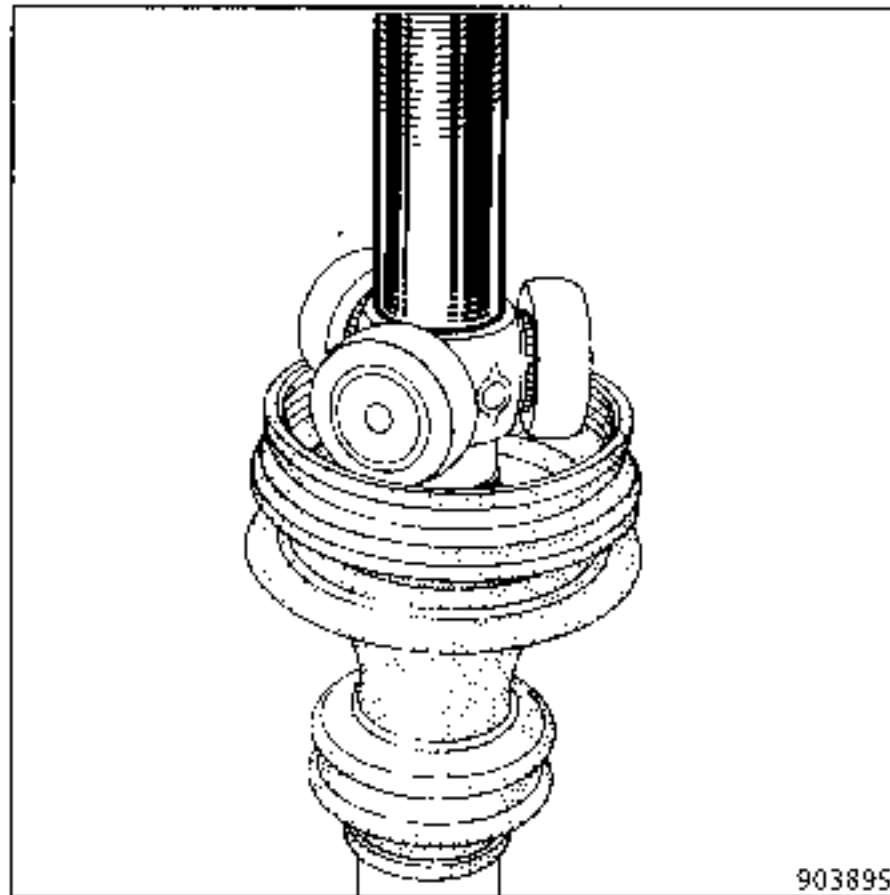

Insert a shim (B) of thickness 2.5 mm (made as shown in the diagram), between the anti-separation plate and the yoke.

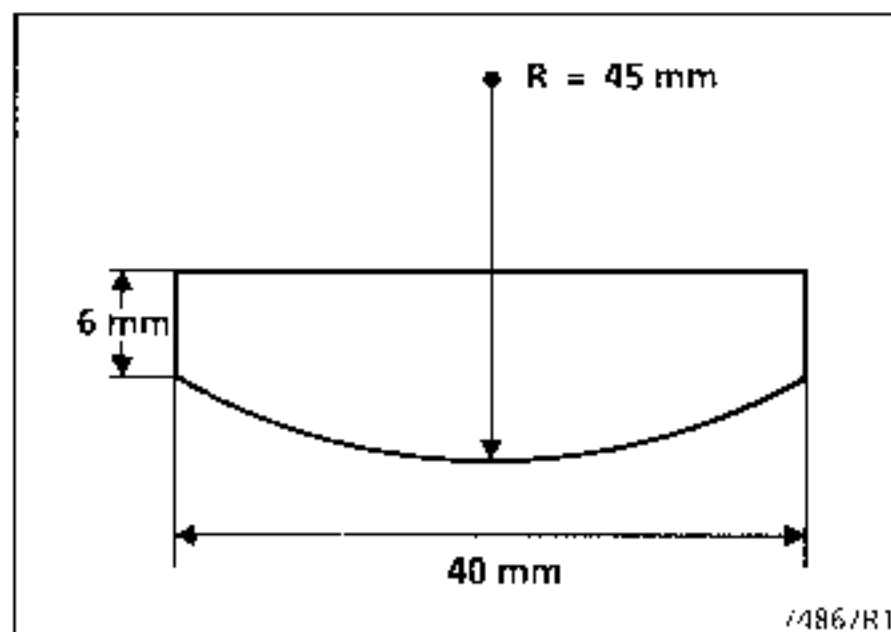

REPLACEMENT (cont)

Using a copper hammer, carefully tap the plate into its original position, then remove the shim (B).

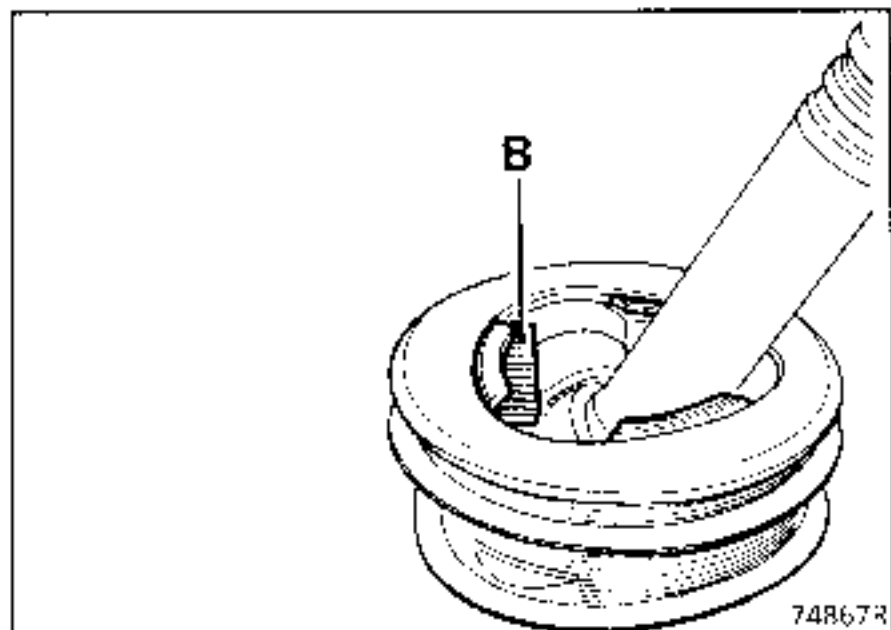

Position the gaiter lips in the grooves on the driveshaft and on the metal cover.

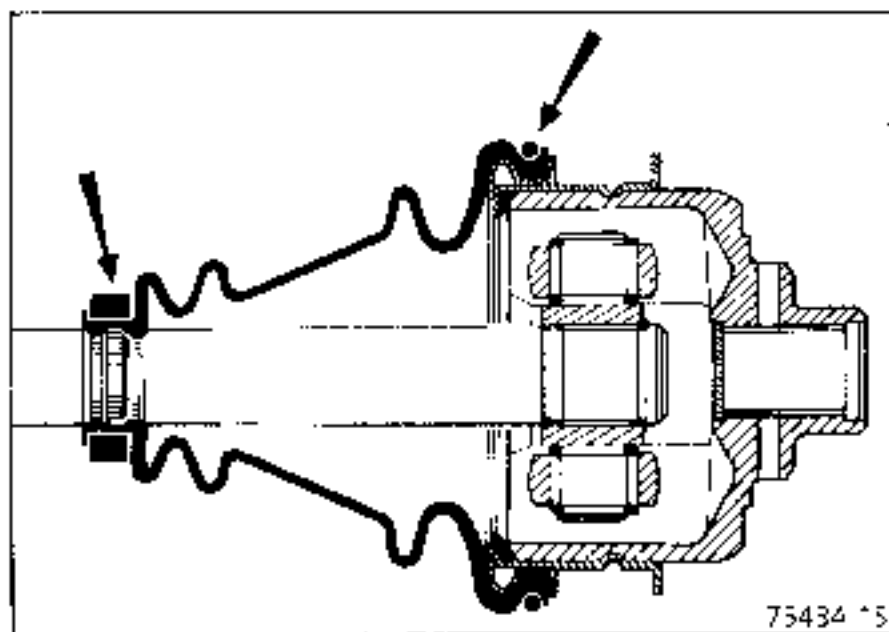

Insert a smooth, rounded end rod between the gaiter and the yoke to correct the amount of air inside the joint.

Expand or shorten the joint until dimension **A** = 153.5 ± 1 mm is obtained (dimension measured between the end of the gaiter and the largest diameter machined face of the yoke).

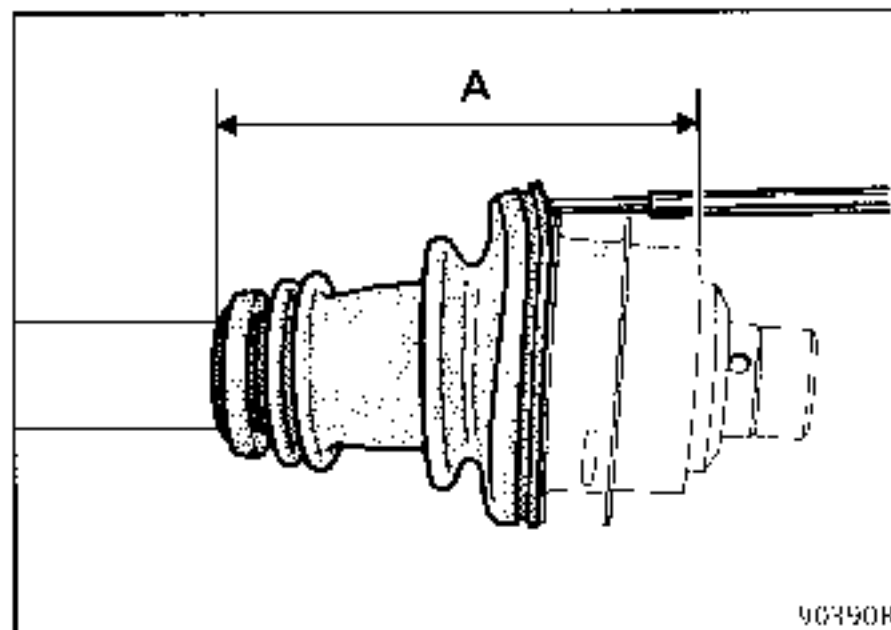

In this position, remove the rod.

Fit the gaiter retaining spring and ring.

- the spring must not be extended,
- the coils must remain touching after assembly.

REPLACEMENT

SPECIAL TOOLING REQUIRED

T.Av. 1034 Pliers for OETIKER
driveshaft clips

- 1 Yoke
- 2 Metal cover
- 3 Spider
- 4 Seal
- 5 Spring
- 6 Stop washer
- 7 Rubber gaiter
- 8 Retaining clip
- 9 Driveshaft

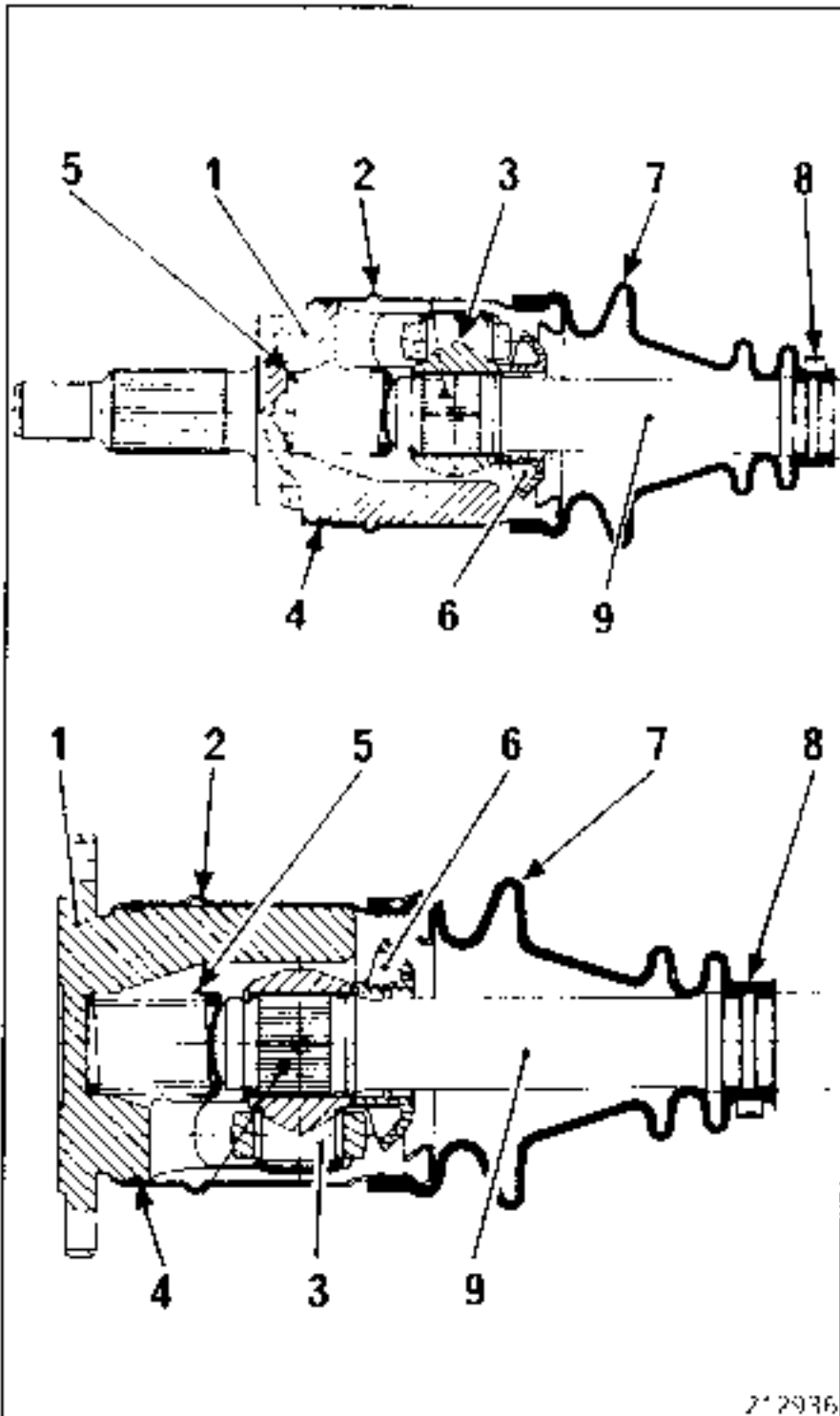

27 2936

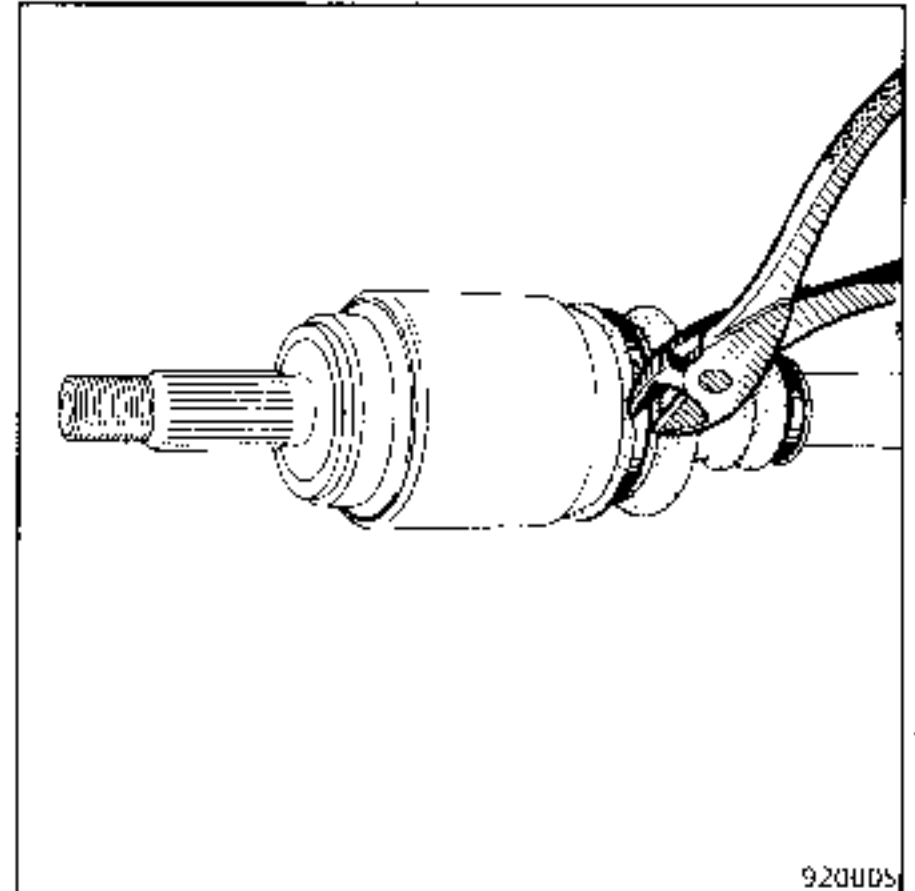

920026

Uncrimp the metal cover from the yoke, release it and remove as much grease as possible.

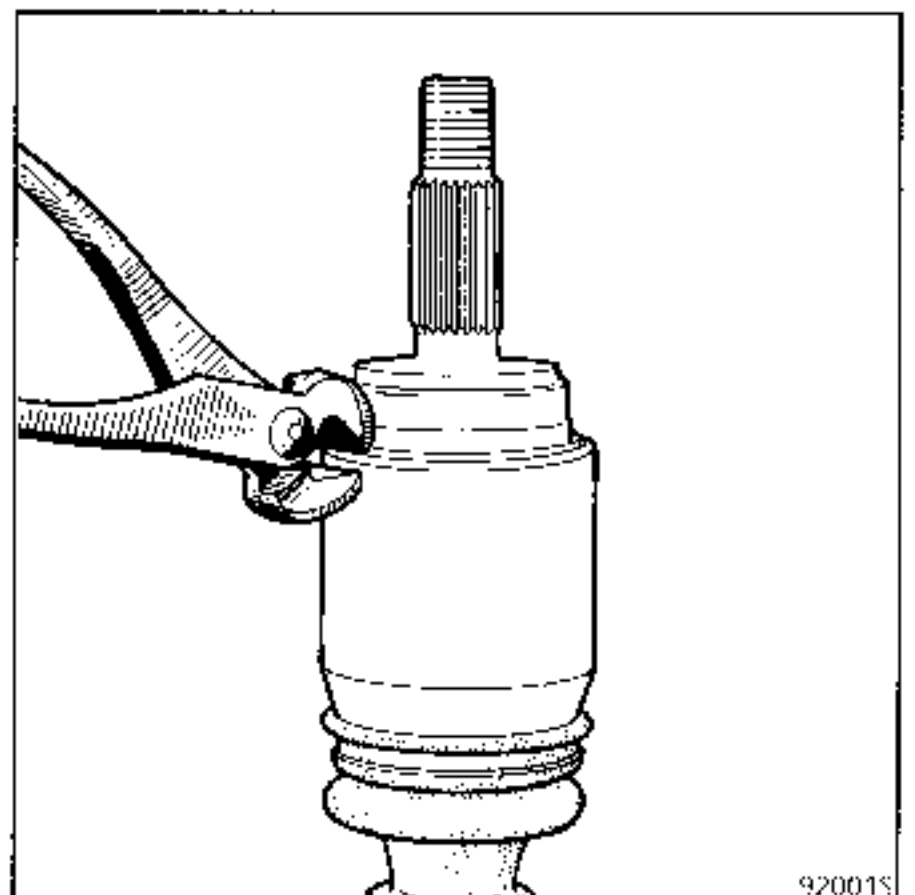

920018

REMOVAL

Cut the crimped clips.

REPLACEMENT (cont)

Remove:

- the yoke (1),
- the spring and its thrust cup (5).

Do not remove the roller cages from their respective trunnions since the cages and rollers are matched and must never be mixed.

Remove the circlip.

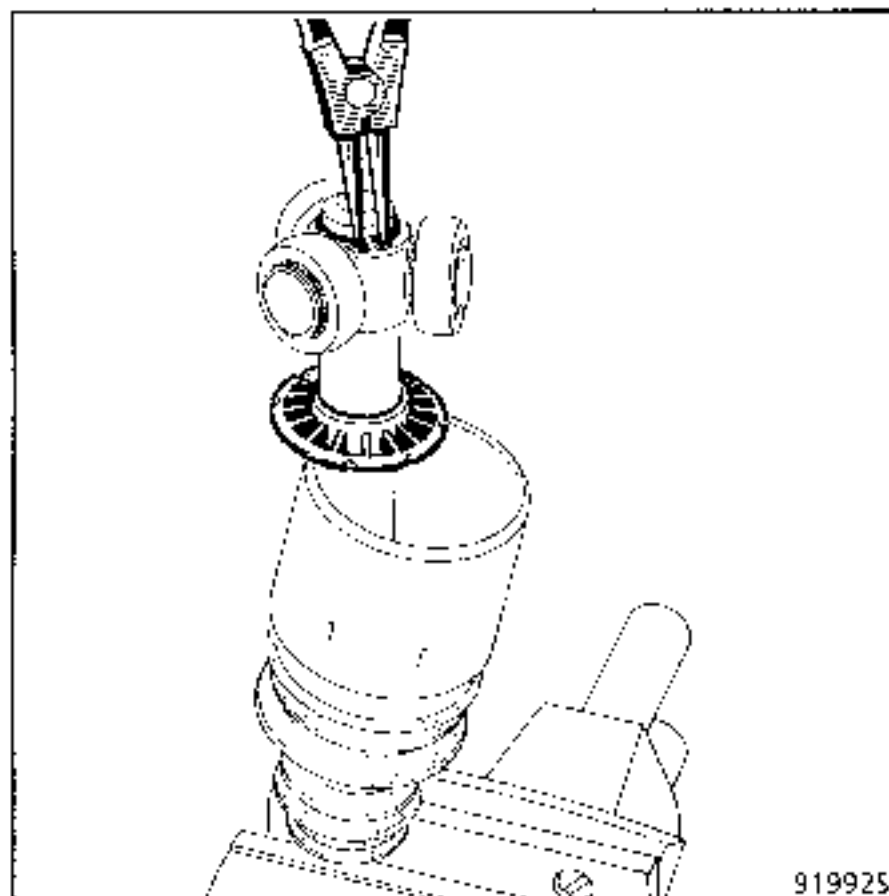

Never use thinners to clean the component parts.

On the press, remove the spider, after marking its position, using a gripping extractor of type FACOM U53G for support.

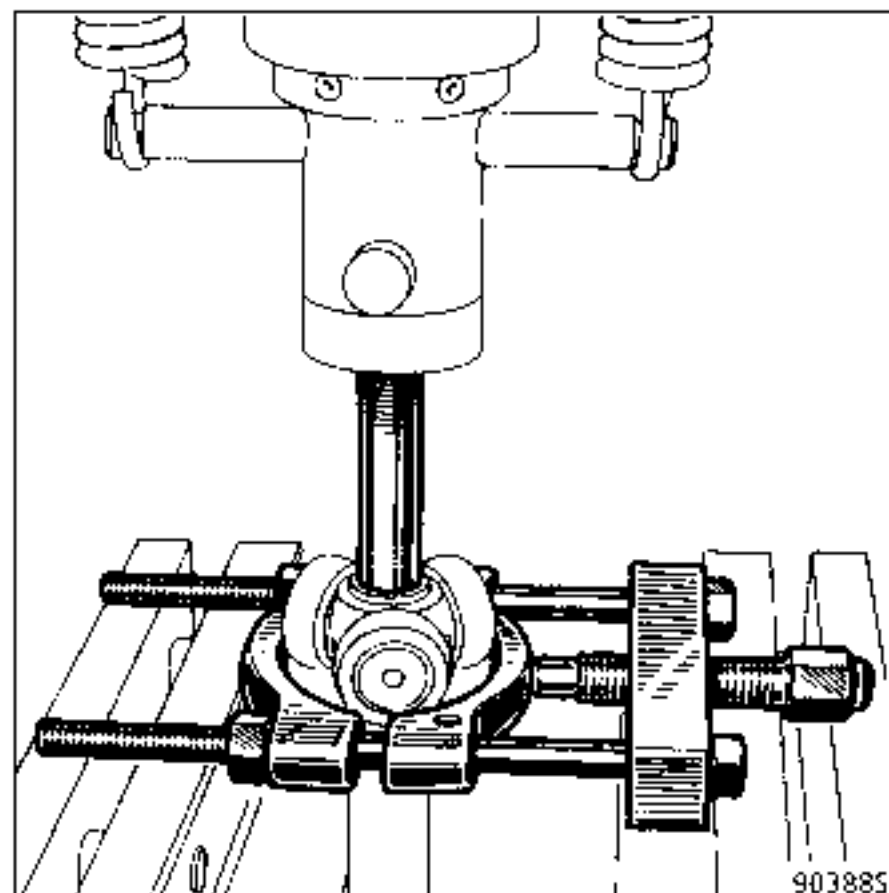

Remove:

- the stop washer (6),
- the cover (2),
- the rubber gaiter (7).

REFITTING

Lubricate the driveshaft and fit :

- the two clips around the shaft if they are not of the "open" type,
- the new gaiter and metal cover,
- the stop washer (6).

Fit the spider onto the splined shaft in the position marked on removal.

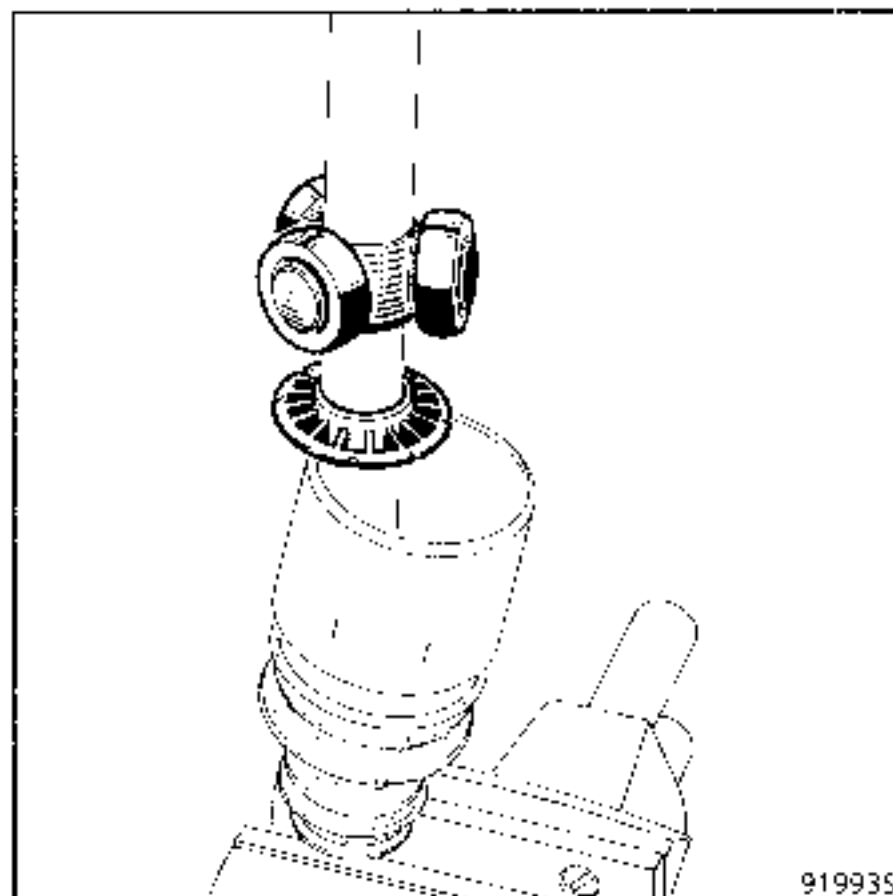

Refit the retaining clip.

Fit the seal (4) into the groove on the yoke. Fit the yoke with the spring and its thrust cup into the cover.

Spread the contents of the sachet of grease in the cover, through the openings in the yoke.

REPLACEMENT (cont)

Position a tool of type **FACOM U53G** on the cover.

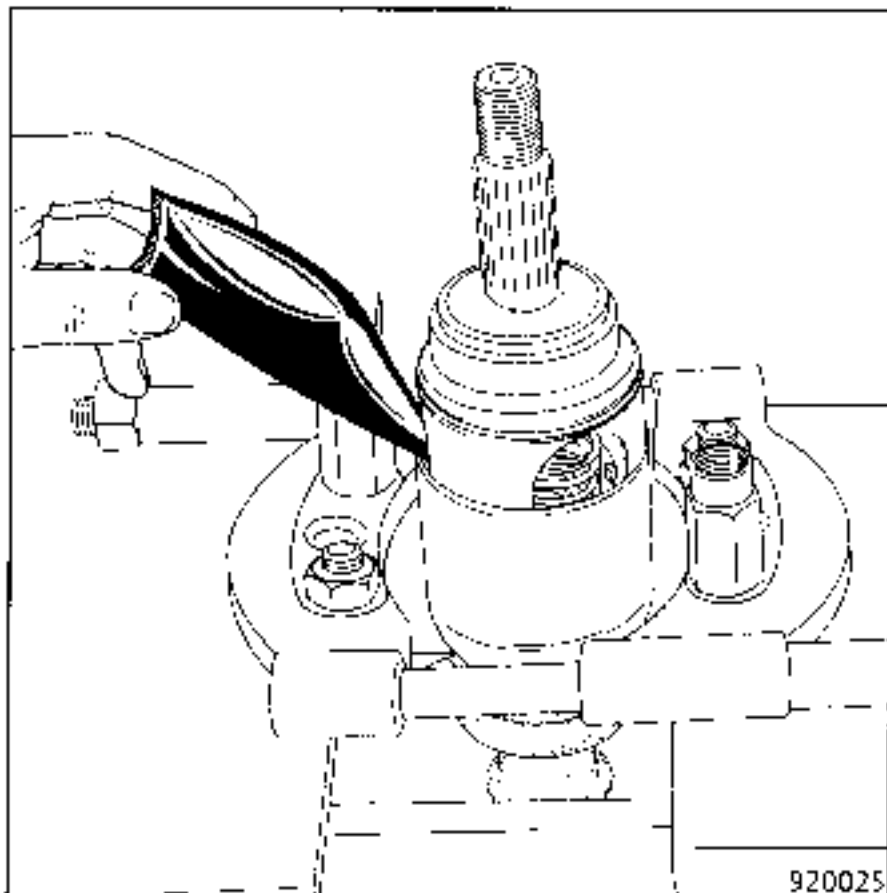

The cover is crimped onto the yoke on the press.

Engage the yoke completely.

DO NOT LET THE PRESSURE INCREASE.

In this position, crimp the cover onto the yoke.

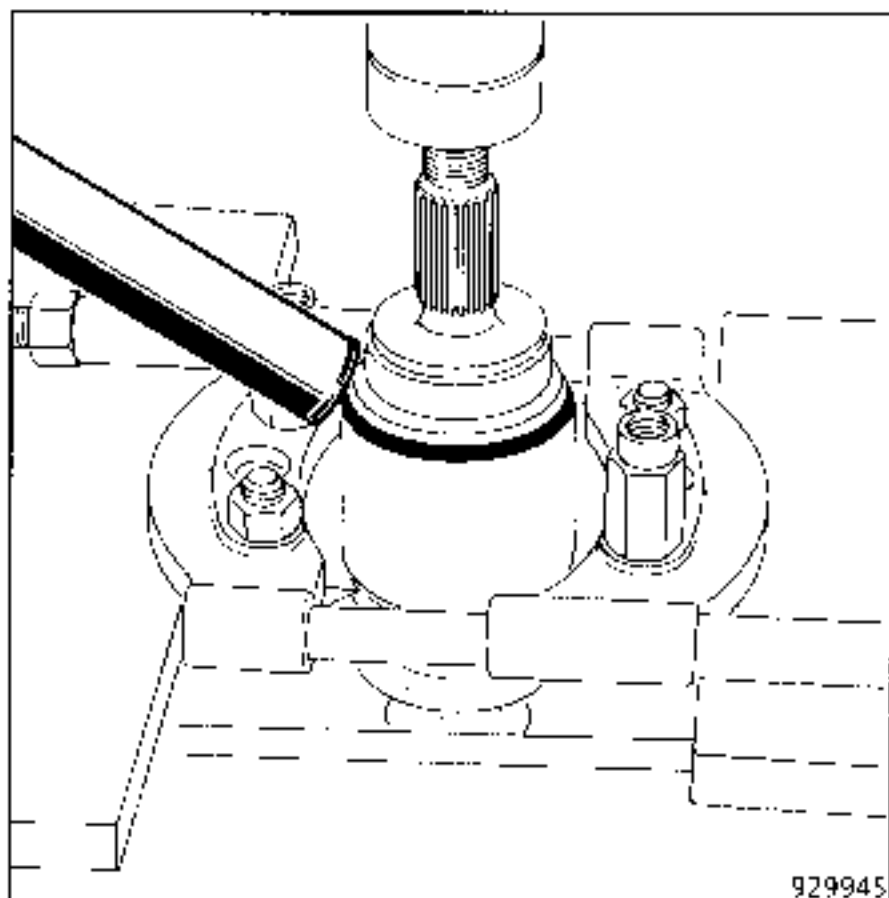

Position the gaiter lips into the grooves on the driveshaft and on the cover.

Insert a smooth, rounded end rod between the gaiter and the shaft to correct the amount of air inside the joint.

Fit the clips and tighten with tool **T.Av. 1034**.

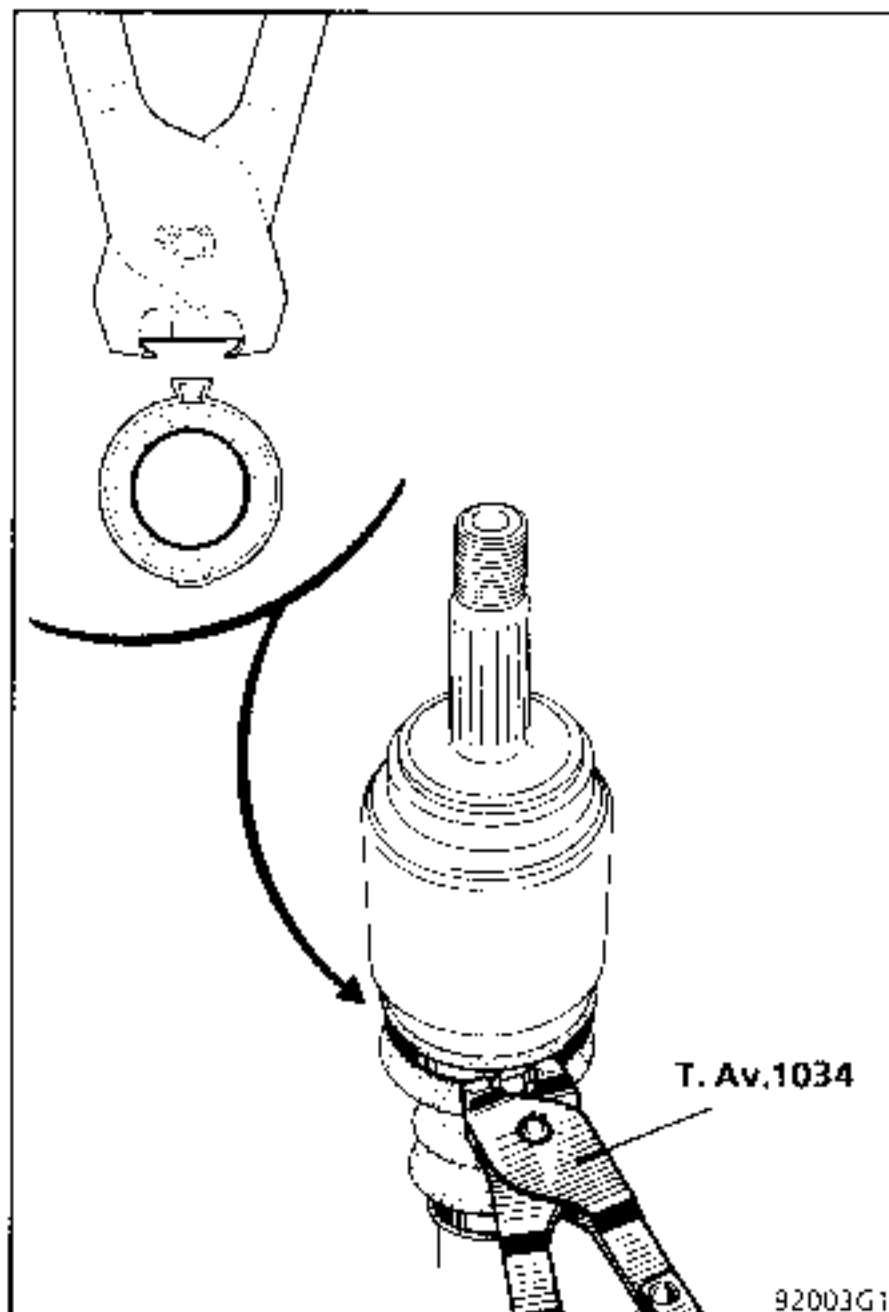

REPLACEMENT

SPECIAL TOOLING REQUIRED		
T.Av.	1331	Mandrel for fitting bearing to shaft

REMOVAL

Never use thinners to clean the component parts.

Depending on assembly, remove the circlip.

Remove the gaiter and bearing assembly in the same manner as the spider.

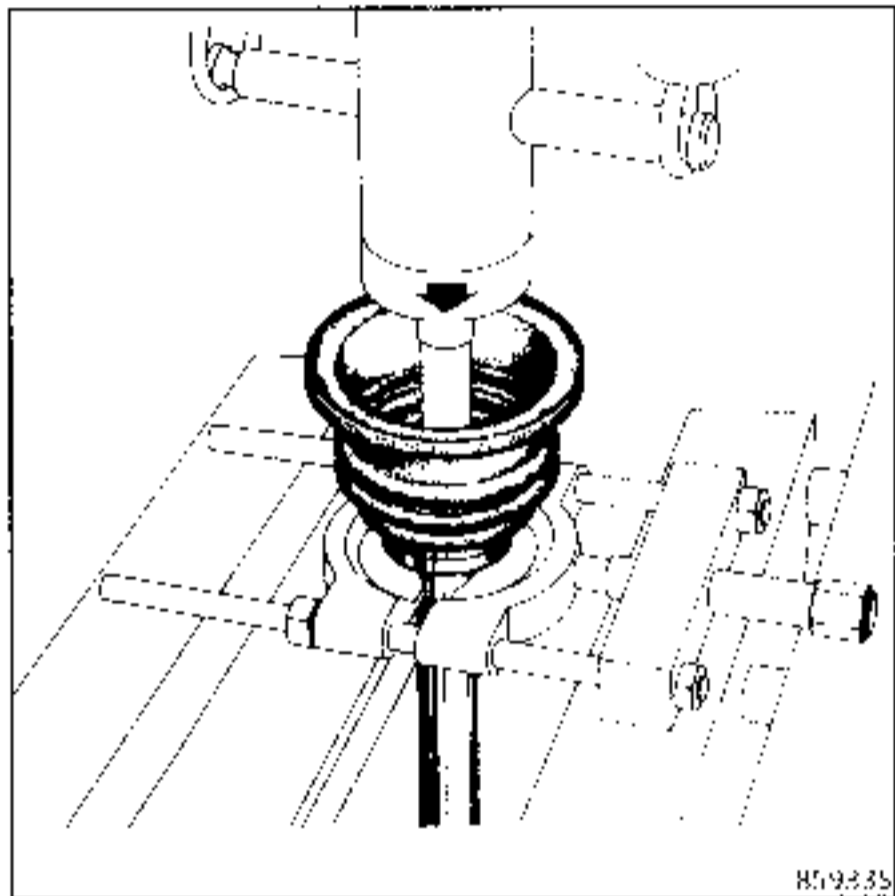
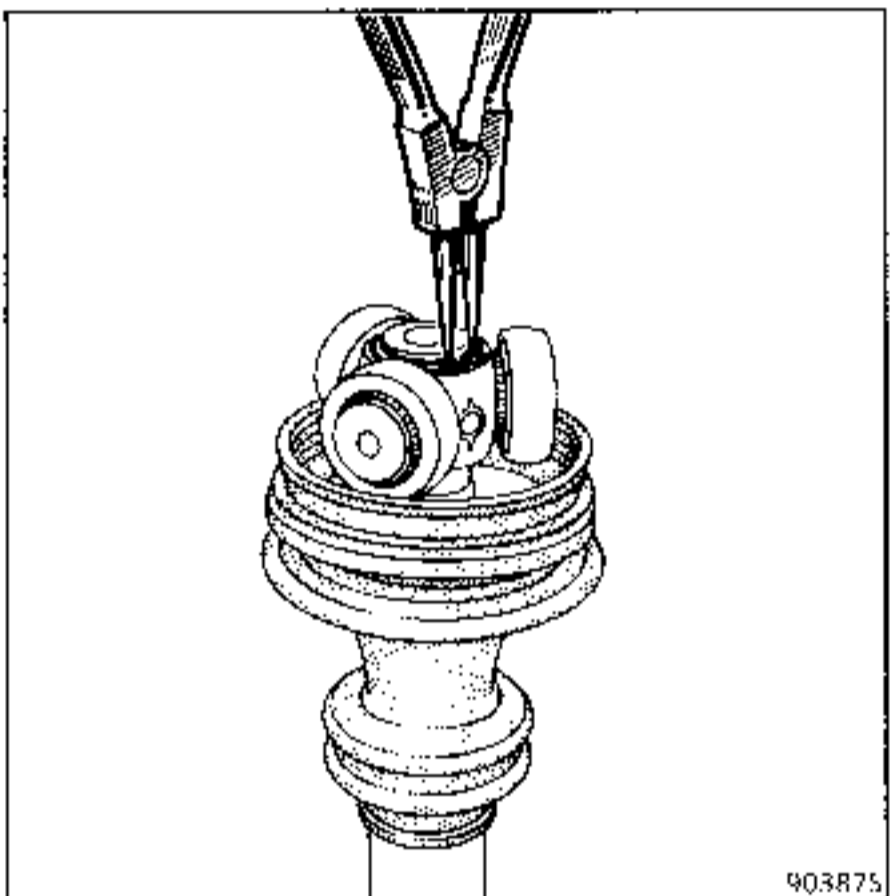

On the press, remove the spider, using a gripping extractor of type **FACOM U53G** for support.

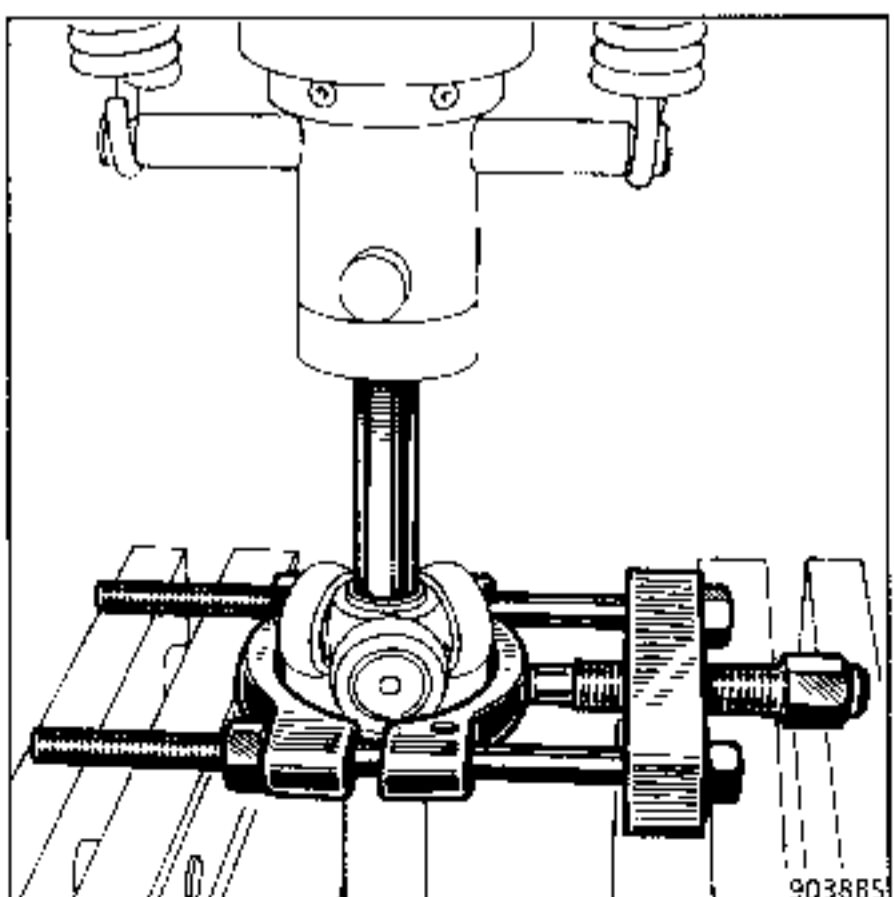

REPLACEMENT (cont)**Refitting**

When in its correct position on the shaft the bearing must be inserted until dimension $L = 148.5$ mm between the rear face of the bearing and the end of the shaft.

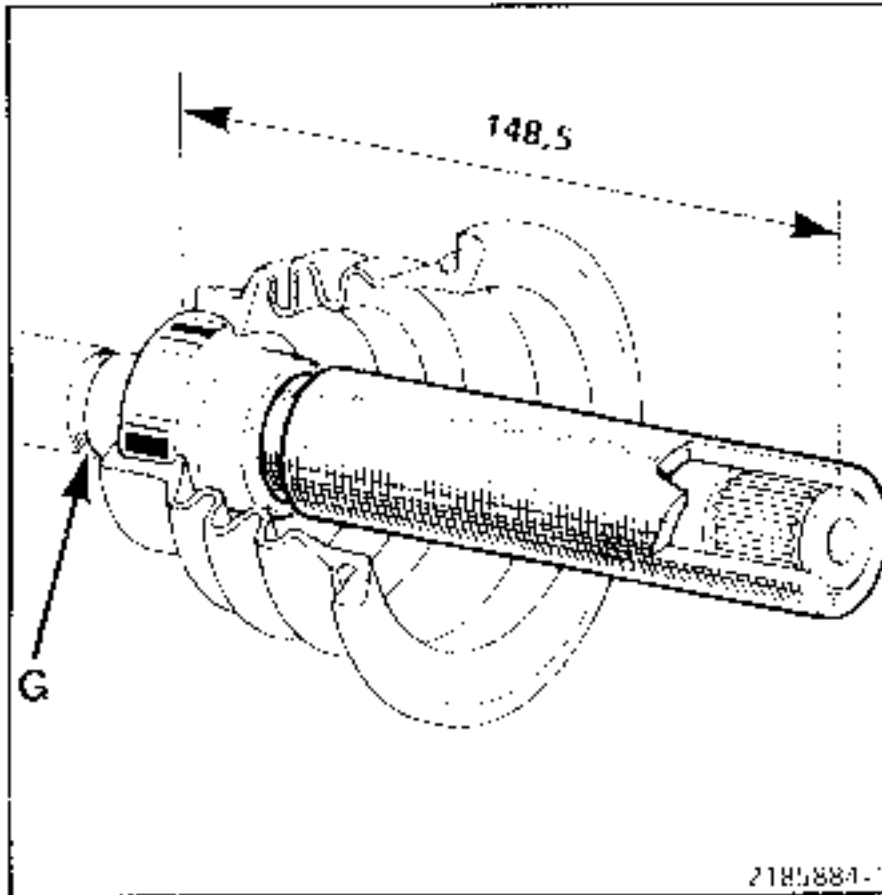

To avoid damage to the bearing which has a lip seal, which could cause a leak, do not use a mallet to fit the bearing, but use the press to allow progressive pressure to be applied.

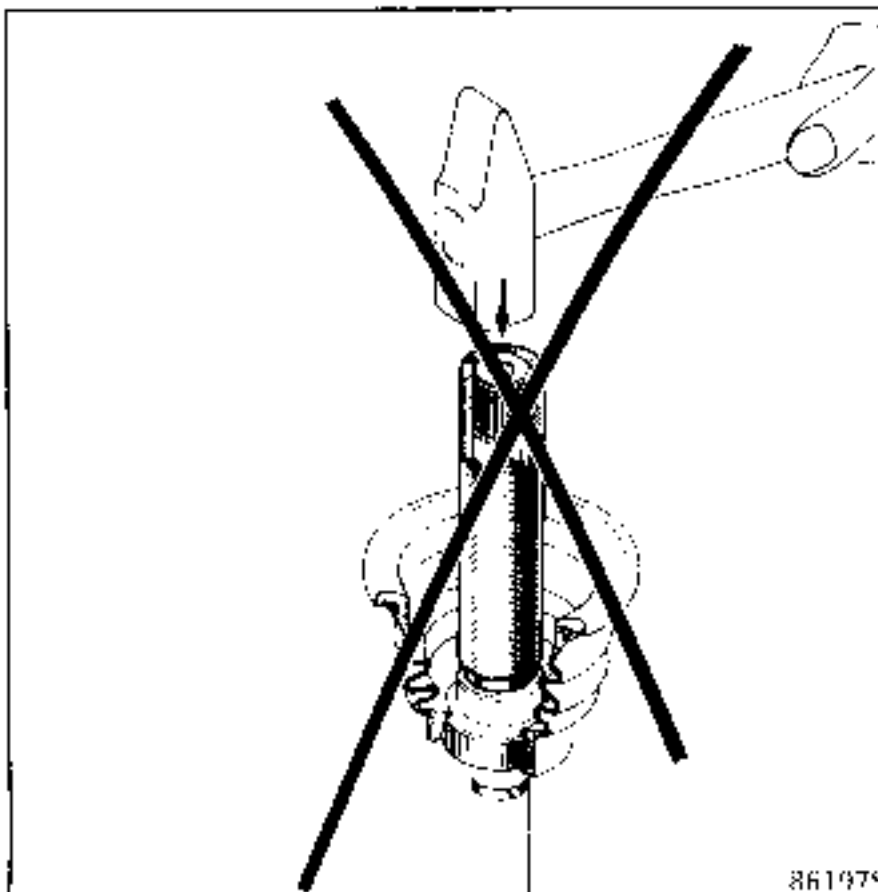

The driveshaft should be held in the press by groove (G) using a tool of type **FACOM U53G** (face plate at gaiter end) to avoid damaging the wheel end joint.

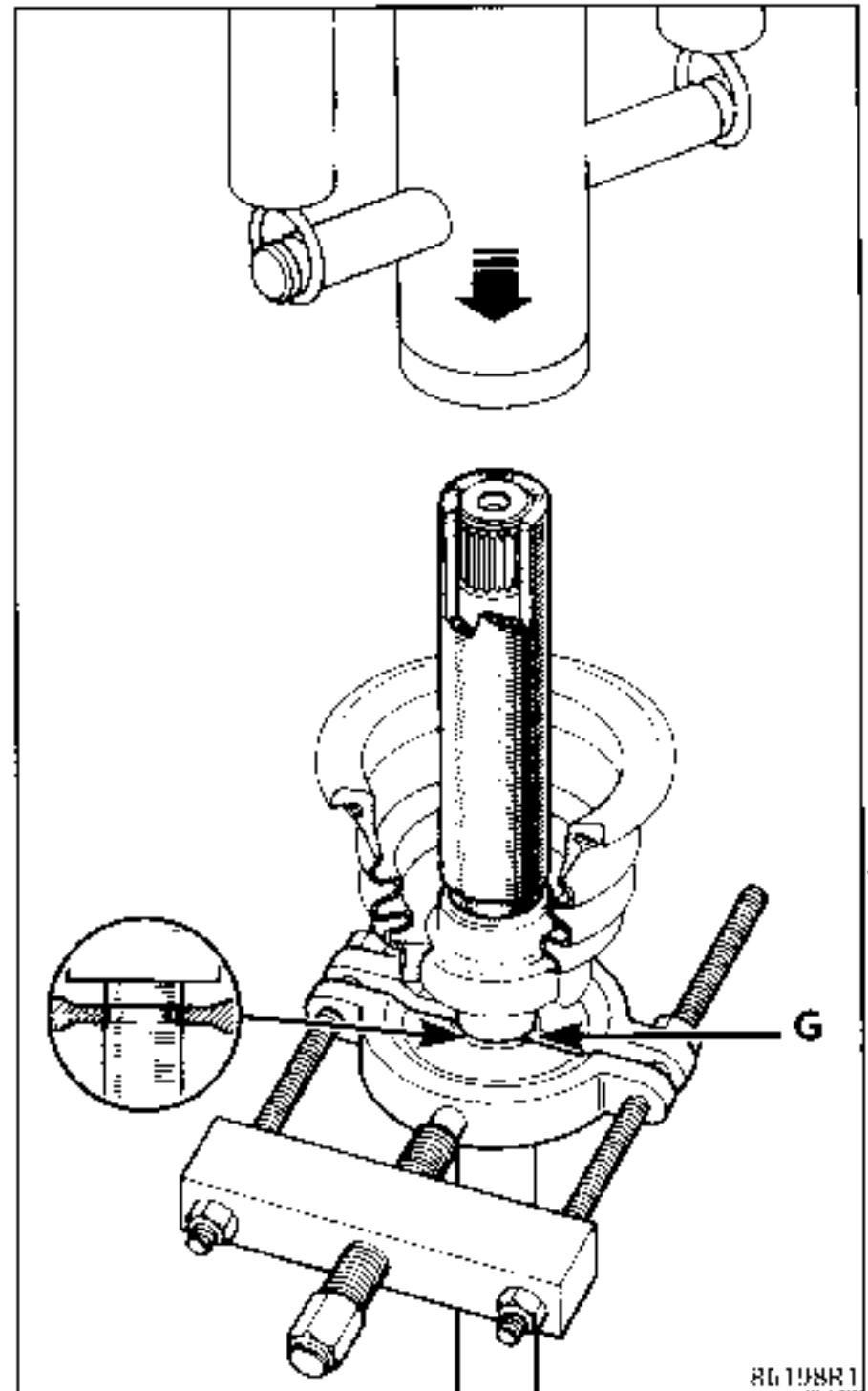

Fit the spider onto the splined shaft and refit the retaining circlip (depending on assembly).

REMOVAL - REFITTING

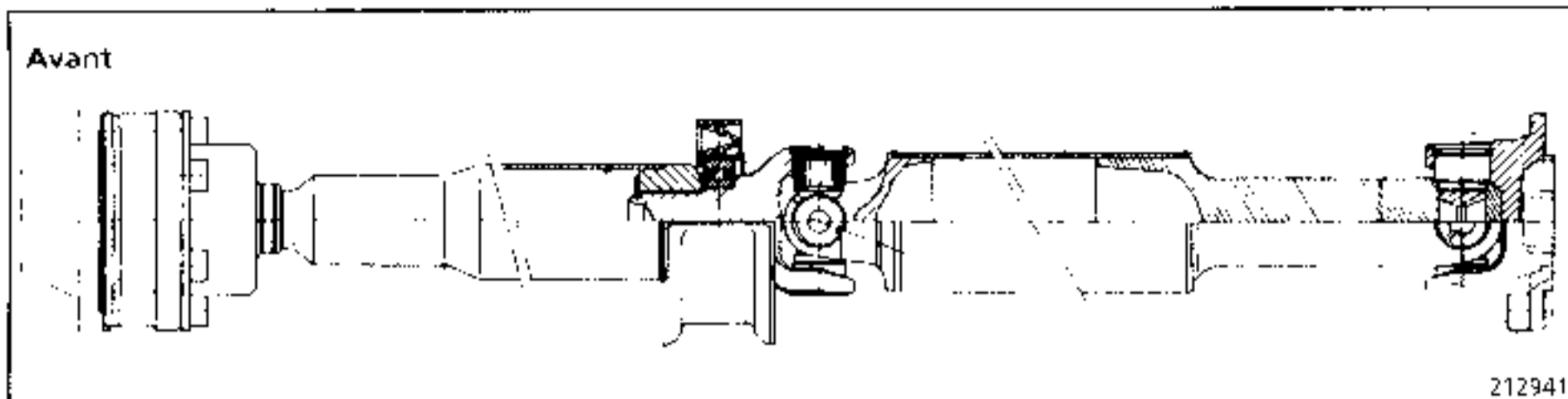

TIGHTENING TORQUES (in daN.m)



Bolt on gearbox output flange	2.5
Bolt on final drive input flange	5
Bearing mounting bolt	2.5

REMOVAL

Remove:

- the bolts on the gearbox output flange,
- the bolts on the final drive input flange.

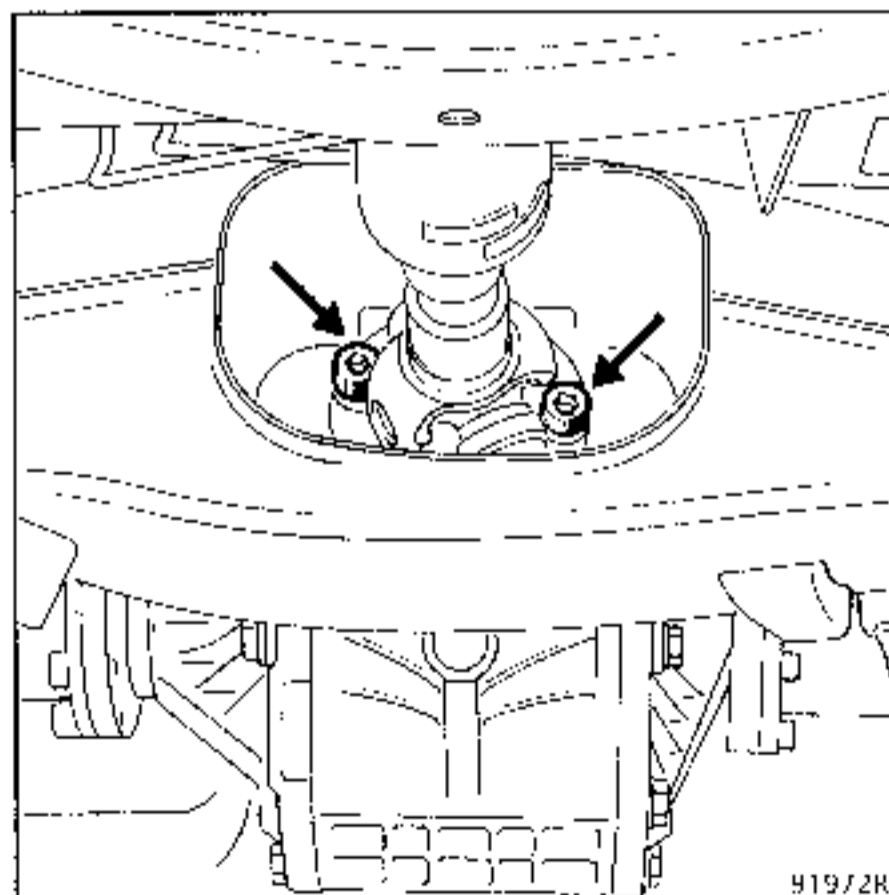

Release the intermediate exhaust pipe.

Remove the mounting bolts from the prop shaft intermediate bearing.

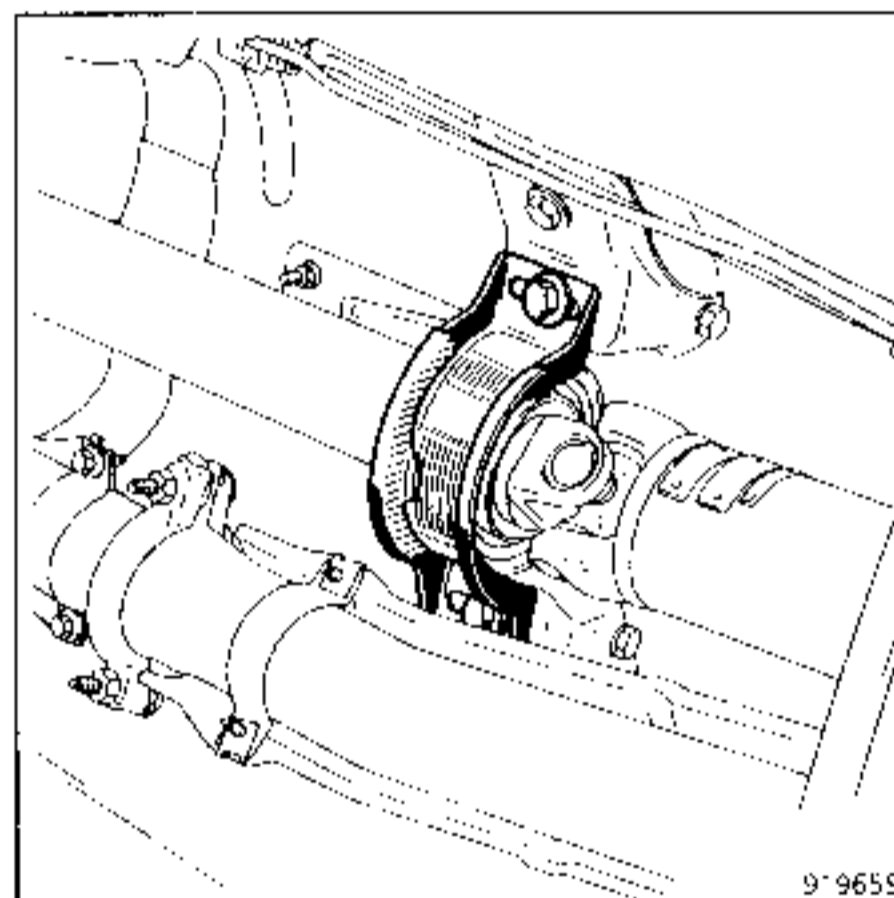

Remove the right hand mounting for the intermediate bearing.

Release the prop shaft from the final drive input flange and place it on the left hand side.

Place the intermediate bearing against the right hand side of the bodywork.

Release the **Lobro** joint from the gearbox output flange and release the left hand side.

Remove the prop shaft.

REFITTING : Special notes

Ensure that the seal is fitted to the gearbox output flange which must be bonded with grease before the driveshaft is fitted.



Tighten the bolts to the correct torque.

REPLACING A UNIVERSAL JOINT CROSS

This operation is carried out after removing the prop shaft.

IMPORTANT : *make marks on the tubes and the flanges to retain the same alignment when refitting.*

REMOVAL

Remove two diametrically opposed circlips.

Using a copper hammer, push one of the needle cages back until the transverse section of the cross is in contact with the clevice (A).

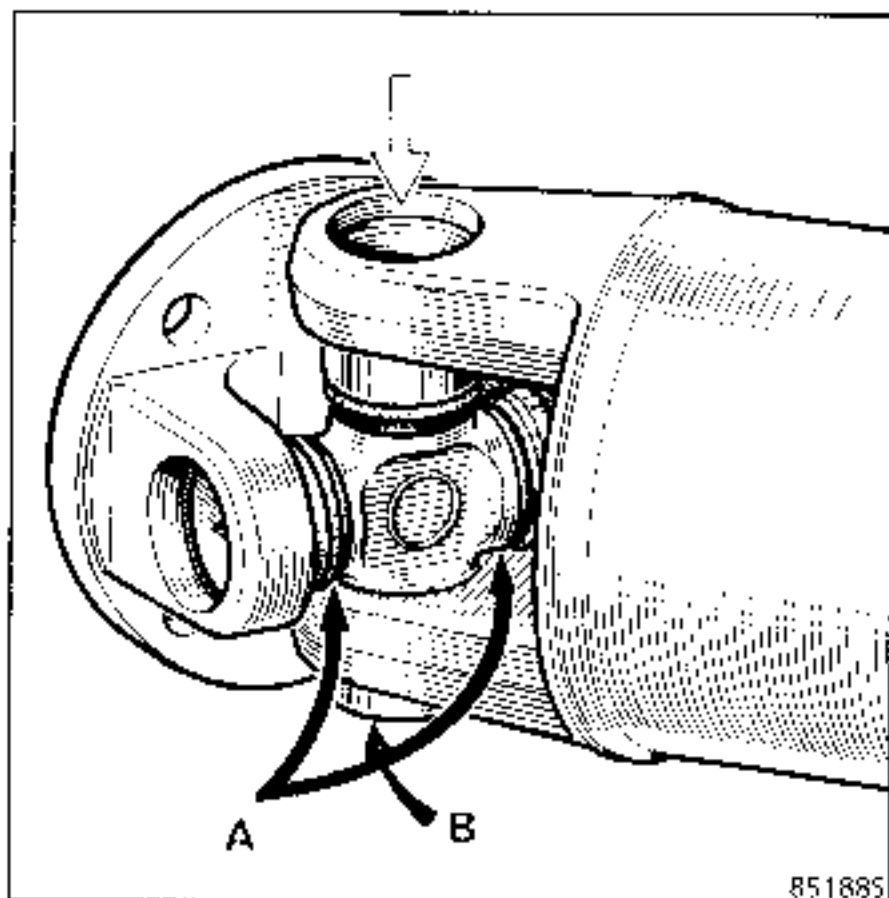

Remove the other cage (B).

Push the shaft back so that the other cage may be released and remove the cross.

Operate in the same manner for the other shaft.

NOTE : if the cage (B) is seized, take the weight on the clevice to push back the other needle cage.

REFITTING

There are no special notes for refitting, other than to ensure the circlips are correctly refitted.

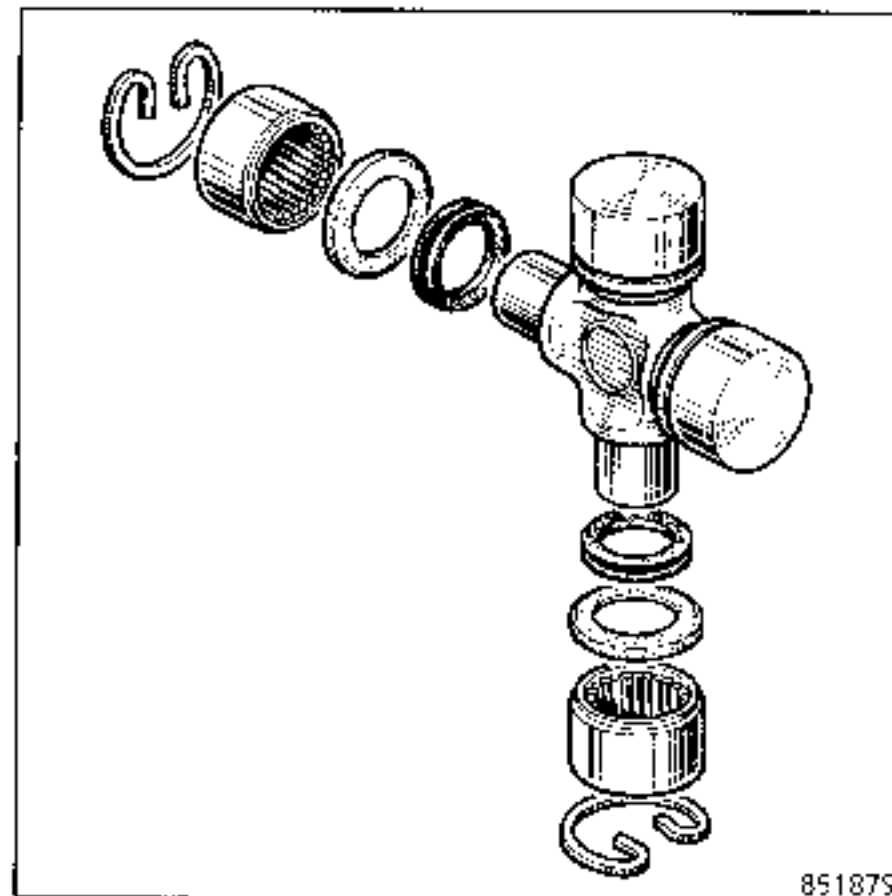

REMOVAL - REFITTING

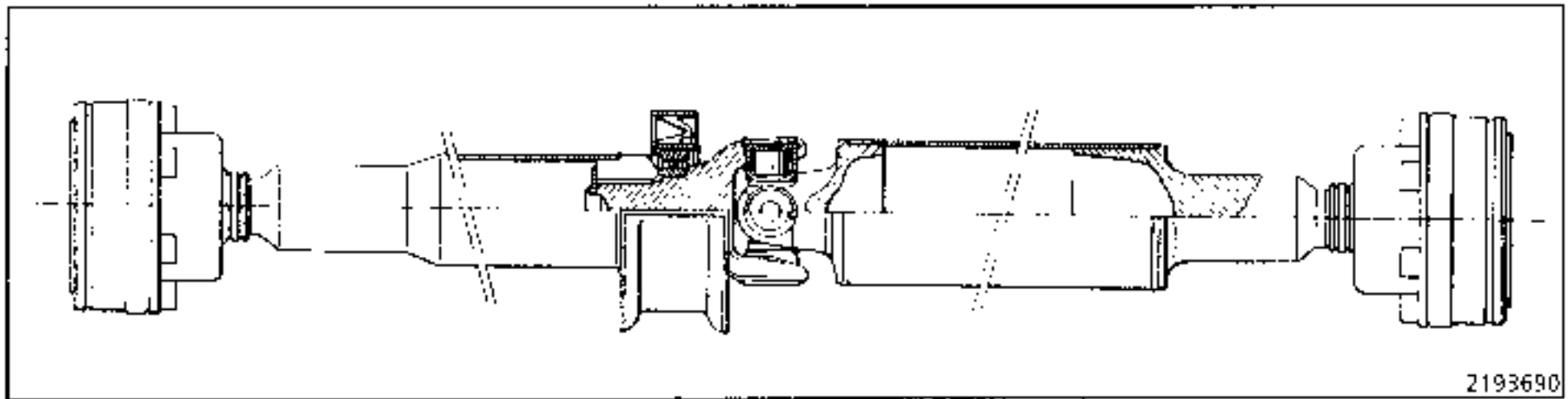

Note: prop shafts on 4 x 4 Integral vehicles are very sensitive to balance, therefore no repairs are permitted and the prop shaft assembly must be systematically replaced.

TIGHTENING TORQUES (in daN.m)	
Bolt on gearbox output flange	2.5
Bolt on final drive input flange	2.5
Bearing mounting bolt	2.5

REMOVAL

Remove:

- the bolts on the gearbox output flange,

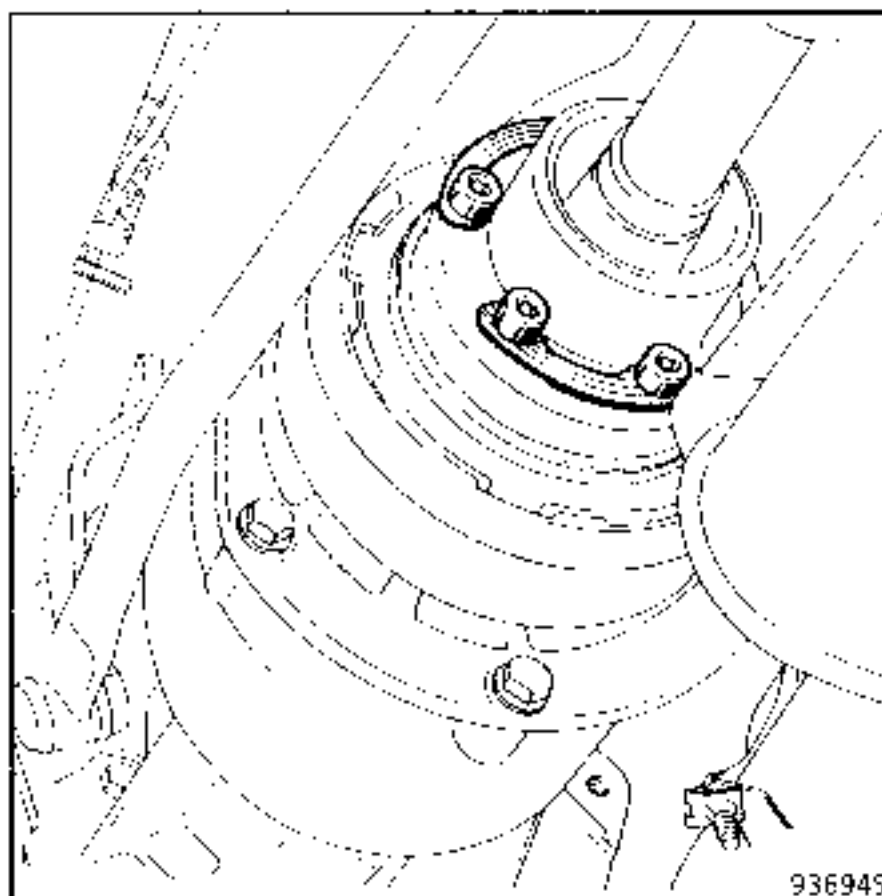

- the bolts on the final drive input flange.

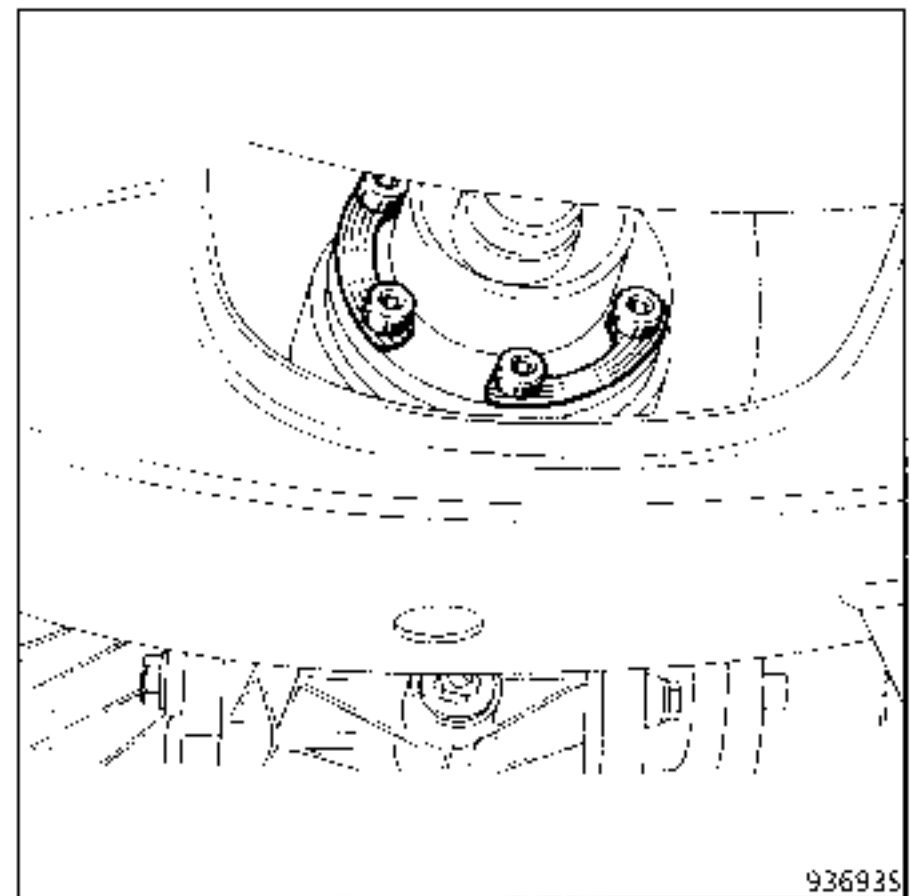

Protect the gaiters.

Remove the mounting bolts from the prop shaft intermediate bearing.

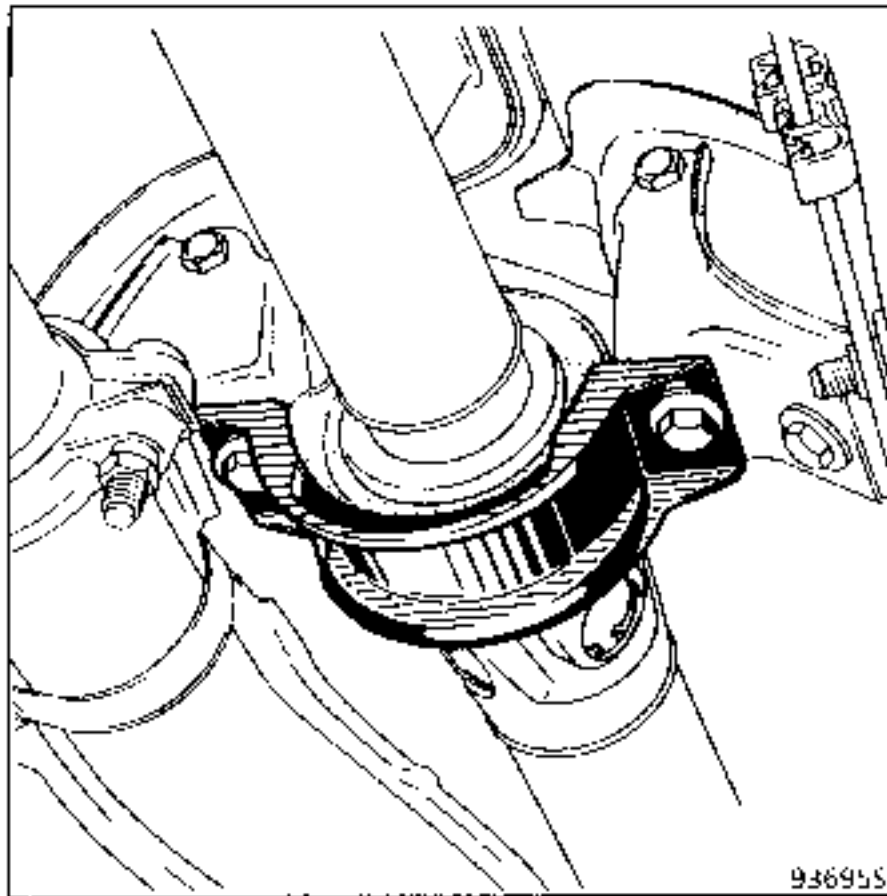

Release the **Lobro** joint from the gearbox output flange and remove the driveshaft.

Note: to avoid damaging the cross and the prop shaft, it must be held simultaneously by the two tubes. The gaiters on the **Lobro** joint must also be protected.

REFITTING : Special notes

The prop shaft mounting bolts must be systematically renewed.

1st assembly:

Ensure the seal is present on the gearbox output flange - it must be bonded with grease before the prop shaft is fitted.

At the final drive end, check the plastic blanking cover is fitted.

2nd assembly:

The gearbox and final drive flanges have a plastic blanking cover which must be assembled **without** an **additional seal** being fitted.

Fit the **Lobro** joints on the flanges, then offer up the bearing to its mountings. Tighten the two bolts but do not lock them. Slide the bearing as far as permitted by the slots. Finally tighten the bearing mounting bolts.



Tighten the bolts to the recommended torque.