

# **Introduction to Power Electronics**

## **INTRODUCTION TO POWER ELECTRONICS**

Power Electronics is a field which combines Power (electric power), Electronics and Control systems.

Power engineering deals with the static and rotating power equipment for the generation, transmission and distribution of electric power.

Electronics deals with the study of solid state semiconductor power devices and circuits for Power conversion to meet the desired control objectives (to control the output voltage and output power).

Power electronics may be defined as the subject of applications of solid state power semiconductor devices (Thyristors) for the control and conversion of electric power.

Power electronics deals with the study and design of Thyristorised power controllers for variety of application like Heat control, Light/Illumination control, Motor control – AC/DC motor drives used in industries, High voltage power supplies, Vehicle propulsion systems, High voltage direct current (HVDC) transmission.

### **BRIEF HISTORY OF POWER ELECTRONICS**

The first Power Electronic Device developed was the Mercury Arc Rectifier during the year 1900. Then the other Power devices like metal tank rectifier, grid controlled vacuum tube rectifier, ignitron, phanotron, thyatron and magnetic amplifier, were developed & used gradually for power control applications until 1950.

The first SCR (silicon controlled rectifier) or Thyristor was invented and developed by Bell Lab's in 1956 which was the first PNPN triggering transistor.

The second electronic revolution began in the year 1958 with the development of the commercial grade Thyristor by the General Electric Company (GE). Thus the new era of power electronics was born. After that many different types of power semiconductor devices & power conversion techniques have been introduced. The power electronics revolution is giving us the ability to convert, shape and control large amounts of power.

### **SOME APPLICATIONS OF POWER ELECTRONICS**

Advertising, air conditioning, aircraft power supplies, alarms, appliances – (domestic and industrial), audio amplifiers, battery chargers, blenders, blowers, boilers, burglar alarms, cement kiln, chemical processing, clothes dryers, computers, conveyors, cranes and hoists, dimmers (light dimmers), displays, electric door openers, electric dryers, electric fans, electric vehicles, electromagnets, electro mechanical electro plating, electronic ignition, electrostatic precipitators, elevators, fans, flashers, food mixers, food warmer trays, fork lift trucks, furnaces, games, garage door openers, gas turbine starting, generator exciters, grinders, hand power tools, heat controls, high frequency lighting, HVDC transmission, induction heating, laser power supplies, latching relays, light flashers, linear induction motor controls, locomotives, machine tools, magnetic recording, magnets, mass transit railway system, mercury arc lamp ballasts, mining, model trains, motor controls, motor drives, movie projectors, nuclear reactor control rod, oil well drilling, oven controls, paper mills, particle accelerators, phonographs, photo copiers, power supplies, printing press, pumps and compressors, radar/sonar power supplies, refrigerators, regulators, RF amplifiers, security systems, servo systems, sewing machines, solar power supplies, solid-state contactors, solid-state relays, static circuit breakers, static relays, steel mills, synchronous motor starting, TV circuits, temperature

controls, timers and toys, traffic signal controls, trains, TV deflection circuits, ultrasonic generators, UPS, vacuum cleaners, VAR compensation, vending machines, VLF transmitters, voltage regulators, washing machines, welding equipment.

## **POWER ELECTRONIC APPLICATIONS**

### **COMMERCIAL APPLICATIONS**

Heating Systems Ventilating, Air Conditioners, Central Refrigeration, Lighting, Computers and Office equipments, Uninterruptible Power Supplies (UPS), Elevators, and Emergency Lamps.

### **DOMESTIC APPLICATIONS**

Cooking Equipments, Lighting, Heating, Air Conditioners, Refrigerators & Freezers, Personal Computers, Entertainment Equipments, UPS.

### **INDUSTRIAL APPLICATIONS**

Pumps, compressors, blowers and fans. Machine tools, arc furnaces, induction furnaces, lighting control circuits, industrial lasers, induction heating, welding equipments.

### **AEROSPACE APPLICATIONS**

Space shuttle power supply systems, satellite power systems, aircraft power systems.

### **TELECOMMUNICATIONS**

Battery chargers, power supplies (DC and UPS), mobile cell phone battery chargers.

### **TRANSPORTATION**

Traction control of electric vehicles, battery chargers for electric vehicles, electric locomotives, street cars, trolley buses, automobile electronics including engine controls.

### **UTILITY SYSTEMS**

High voltage DC transmission (HVDC), static VAR compensation (SVC), Alternative energy sources (wind, photovoltaic), fuel cells, energy storage systems, induced draft fans and boiler feed water pumps.

### **POWER SEMICONDUCTOR DEVICES**

- Power Diodes.
- Power Transistors (BJT's).
- Power MOSFETS.
- IGBT's.
- Thyristors

Thyristors are a family of p-n-p-n structured power semiconductor switching devices

- SCR's (Silicon Controlled Rectifier)

The silicon controlled rectifier is the most commonly and widely used member of the thyristor family. The family of thyristor devices include SCR's, Diacs, Triacs, SCS, SUS, LASCR's and so on.



## **POWER SEMICONDUCTOR DEVICES USED IN POWER ELECTRONICS**

The first thyristor or the SCR was developed in 1957. The conventional Thyristors (SCR's) were exclusively used for power control in industrial applications until 1970. After 1970, various types of power semiconductor devices were developed and became commercially available. The power semiconductor devices can be divided broadly into five types

- Power Diodes.
- Thyristors.
- Power BJT's.
- Power MOSFET's.
- Insulated Gate Bipolar Transistors (IGBT's).
- Static Induction Transistors (SIT's).

The Thyristors can be subdivided into different types

- Forced-commutated Thyristors (Inverter grade Thyristors)
- Line-commutated Thyristors (converter-grade Thyristors)
- Gate-turn off Thyristors (GTO).
- Reverse conducting Thyristors (RCT's).
- Static Induction Thyristors (SITH).
- Gate assisted turn-off Thyristors (GATT).
- Light activated silicon controlled rectifier (LASCR) or Photo SCR's.
- MOS-Controlled Thyristors (MCT's).

## **POWER DIODES**

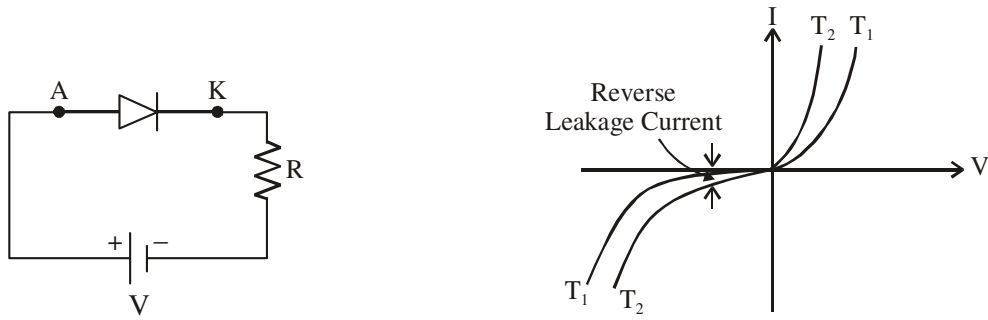
Power diodes are made of silicon p-n junction with two terminals, anode and cathode. P-N junction is formed by alloying, diffusion and epitaxial growth. Modern techniques in diffusion and epitaxial processes permit desired device characteristics.

The diodes have the following advantages

- High mechanical and thermal reliability
- High peak inverse voltage
- Low reverse current
- Low forward voltage drop
- High efficiency
- Compactness.

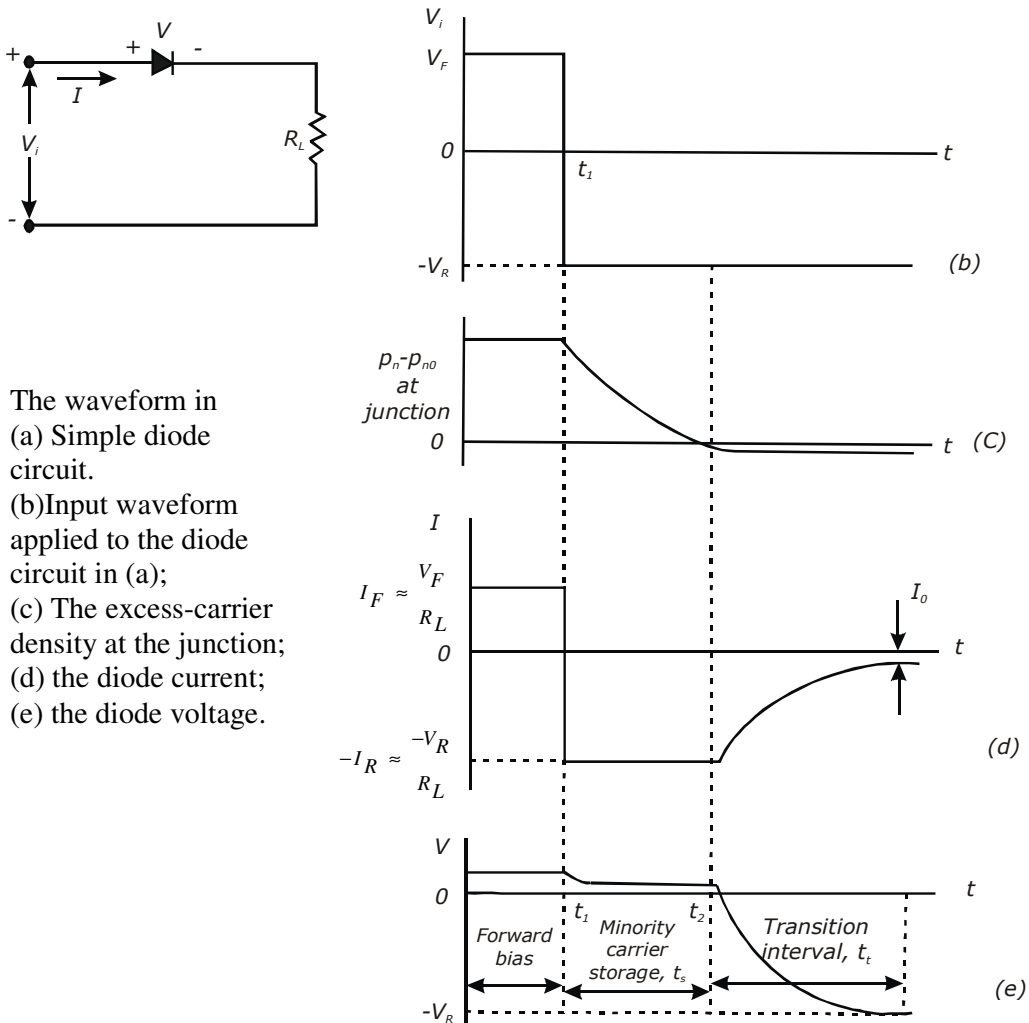
Diode is forward biased when anode is made positive with respect to the cathode. Diode conducts fully when the diode voltage is more than the cut-in voltage (0.7 V for Si). Conducting diode will have a small voltage drop across it.

Diode is reverse biased when cathode is made positive with respect to anode. When reverse biased, a small reverse current known as leakage current flows. This leakage current increases with increase in magnitude of reverse voltage until avalanche voltage is reached (breakdown voltage).



### DYNAMIC CHARACTERISTICS OF POWER SWITCHING DIODES

At low frequency and low current, the diode may be assumed to act as a perfect switch and the dynamic characteristics (turn on & turn off characteristics) are not very important. But at high frequency and high current, the dynamic characteristics plays an important role because it increases power loss and gives rise to large voltage spikes which may damage the device if proper protection is not given to the device.



- (a) Simple diode circuit.
- (b) Input waveform applied to the diode circuit in (a);
- (c) The excess-carrier density at the junction;
- (d) the diode current;
- (e) the diode voltage.

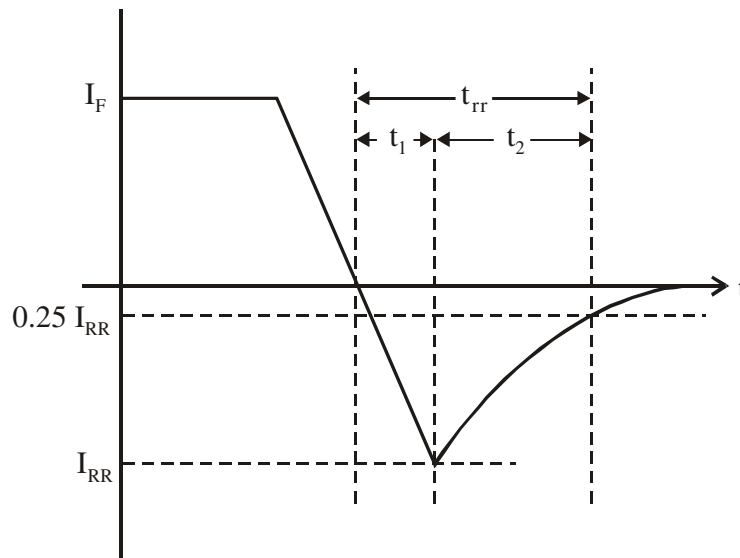
**Fig: Storage & Transition Times during the Diode Switching**

## REVERSE RECOVERY CHARACTERISTIC

Reverse recovery characteristic is much more important than forward recovery characteristics because it adds recovery losses to the forward loss. Current when diode is forward biased is due to net effect of majority and minority carriers. When diode is in forward conduction mode and then its forward current is reduced to zero (by applying reverse voltage) the diode continues to conduct due to minority carriers which remains stored in the p-n junction and in the bulk of semi-conductor material. The minority carriers take some time to recombine with opposite charges and to be neutralized. This time is called the **reverse recovery time**. The reverse recovery time ( $t_{rr}$ ) is measured from the initial zero crossing of the diode current to 25% of maximum reverse current  $I_{RR}$ .  $t_{rr}$  has 2 components,  $t_1$  and  $t_2$ .  $t_1$  is as a result of charge storage in the depletion region of the junction i.e., it is the time between the zero crossing and the peak reverse current  $I_{RR}$ .  $t_2$  is as a result of charge storage in the bulk semi-conductor material.

$$t_{rr} = t_1 + t_2$$

$$I_{RR} = t_1 \left( \frac{di}{dt} \right)$$



**The reverse recovery time** depends on the junction temperature, rate of fall of forward current and the magnitude of forward current prior to commutation (turning off). When diode is in reverse biased condition the flow of leakage current is due to minority carriers. Then application of forward voltage would force the diode to carry current in the forward direction. But a certain time known as forward recovery time (turn-ON time) is required before all the majority carriers over the whole junction can contribute to current flow. Normally forward recovery time is less than the reverse recovery time. The forward recovery time limits the rate of rise of forward current and the switching speed.

**Reverse recovery charge**  $Q_{RR}$ , is the amount of charge carriers that flow across the diode in the reverse direction due to the change of state from forward conduction to

reverse blocking condition. The value of reverse recovery charge  $Q_{RR}$  is determined from the area enclosed by the path of the reverse recovery current.

$$Q_{RR} \cong \left( \frac{1}{2} I_{RR} t_1 + \frac{1}{2} I_{RR} t_2 \right) = \frac{1}{2} I_{RR} t_{RR} \quad \therefore Q_{RR} = \frac{1}{2} I_{RR} t_{RR}$$

## POWER DIODES TYPES

Power diodes can be classified as

- General purpose diodes.
- High speed (fast recovery) diodes.
- Schottky diode.

## GENERAL PURPOSE DIODES

The diodes have high reverse recovery time of about 25 microseconds ( $\mu\text{sec}$ ). They are used in low speed (frequency) applications. e.g., line commutated converters, diode rectifiers and converters for a low input frequency upto 1 KHz. Diode ratings cover a very wide range with current ratings less than 1 A to several thousand amps (2000 A) and with voltage ratings from 50 V to 5 KV. These diodes are generally manufactured by diffusion process. Alloyed type rectifier diodes are used in welding power supplies. They are most cost effective and rugged and their ratings can go upto 300A and 1KV.

## FAST RECOVERY DIODES

The diodes have low recovery time, generally less than 5  $\mu\text{s}$ . The major field of applications is in electrical power conversion i.e., in free-wheeling ac-dc and dc-ac converter circuits. Their current ratings is from less than 1 A to hundreds of amperes with voltage ratings from 50 V to about 3 KV. Use of fast recovery diodes are preferable for free-wheeling in SCR circuits because of low recovery loss, lower junction temperature and reduced  $di/dt$ . For high voltage ratings greater than 400 V they are manufactured by diffusion process and the recovery time is controlled by platinum or gold diffusion. For less than 400 V rating epitaxial diodes provide faster switching speeds than diffused diodes. Epitaxial diodes have a very narrow base width resulting in a fast recovery time of about 50 ns.

## SCHOTTKY DIODES

A Schottky diode has metal (aluminium) and semi-conductor junction. A layer of metal is deposited on a thin epitaxial layer of the n-type silicon. In Schottky diode there is a larger barrier for electron flow from metal to semi-conductor.

When Schottky diode is forward biased free electrons on n-side gain enough energy to flow into the metal causing forward current. Since the metal does not have any holes there is no charge storage, decreasing the recovery time. Therefore a Schottky diode can switch-off faster than an ordinary p-n junction diode. A Schottky diode has a relatively low forward voltage drop and reverse recovery losses. The leakage current is higher than a p-n junction diode. The maximum allowable voltage is about 100 V. Current ratings vary from about 1 to 300 A. They are mostly used in low voltage and high current dc power supplies. The operating frequency may be as high 100-300 kHz as the

device is suitable for high frequency application. Schottky diode is also known as hot carrier diode.

General Purpose Diodes are available upto 5000V, 3500A. The rating of fast-recovery diodes can go upto 3000V, 1000A. The reverse recovery time varies between 0.1 and 5μsec. The fast recovery diodes are essential for high frequency switching of power converters. Schottky diodes have low-on-state voltage drop and very small recovery time, typically a few nanoseconds. Hence turn-off time is very low for schottky diodes. The leakage current increases with the voltage rating and their ratings are limited to 100V, 300A. The diode turns on and begins to conduct when it is forward biased. When the anode voltage is greater than the cathode voltage diode conducts.

The forward voltage drop of a power diode is low typically 0.5V to 1.2V. If the cathode voltage is higher than its anode voltage then the diode is said to be reverse biased.

Power diodes of high current rating are available in

- Stud or stud-mounted type.
- Disk or press pack or Hockey-pack type.

In a stud mounted type, either the anode or the cathode could be the stud.

### COMPARISON BETWEEN DIFFERENT TYPES OF DIODES

General Purpose Diodes	Fast Recovery Diodes	Schottky Diodes
Upto 5000V & 3500A	Upto 3000V and 1000A	Upto 100V and 300A
Reverse recovery time – High	Reverse recovery time – Low	Reverse recovery time – Extremely low.
$t_{rr} \approx 25\mu s$	$t_{rr} = 0.1\mu s$ to $5\mu s$	$t_{rr} =$ a few nanoseconds
Turn off time - High	Turn off time - Low	Turn off time – Extremely low
Switching frequency – Low	Switching frequency – High	Switching frequency – Very high.
$V_F = 0.7V$ to $1.2V$	$V_F = 0.8V$ to $1.5V$	$V_F \approx 0.4V$ to $0.6V$

Natural or AC line commutated Thyristors are available with ratings upto 6000V, 3500A.

The turn-off time of high speed reverse blocking Thyristors have been improved substantially and now devices are available with  $t_{OFF} = 10$  to  $20\mu sec$  for a 1200V, 2000A Thyristors.

RCT's (reverse conducting Thyristors) and GATT's (gate assisted turn-off Thyristors) are widely used for high speed switching especially in traction applications. An RCT can be considered as a thyristor with an inverse parallel diode. RCT's are available up to 2500V, 1000A (& 400A in reverse conduction) with a switching time of 40μsec. GATT's are available upto 1200V, 400A with a switching speed of 8μsec. LASCR's which are available upto 6000V, 1500A with a switching speed of 200μsec to 400μsec are suitable for high voltage power systems especially in HVDC.

For low power AC applications, triac's are widely used in all types of simple heat controls, light controls, AC motor controls, and AC switches. The characteristics of

triac's are similar to two SCR's connected in inverse parallel and having only one gate terminal. The current flow through a triac can be controlled in either direction.

**GTO's & SITH's** are self turn-off Thyristors. GTO's & SITH's are turned ON by applying a short positive pulse to the gate and are turned off by applying a short negative pulse to the gates. They do not require any commutation circuits.

GTO's are very attractive for forced commutation of converters and are available up to 4000V, 3000A.

SITH's with ratings as high as 1200V and 300A are expected to be used in medium power converters with a frequency of several hundred KHz and beyond the frequency range of GTO.

An MCT (MOS controlled thyristor) can be turned ON by a small negative voltage pulse on the MOS gate (with respect to its anode) and turned OFF by a small positive voltage pulse. It is like a GTO, except that the turn off gain is very high. MCT's are available up to 1000V and 100A.

High power bipolar transistors (high power BJT's) are commonly used in power converters at a frequency below 10KHz and are effectively used in circuits with power ratings up to 1200V, 400A.

A high power BJT is normally operated as a switch in the common emitter configuration.

The forward voltage drop of a conducting transistor (in the ON state) is in the range of 0.5V to 1.5V across collector and emitter. That is  $V_{CE} = 0.5V$  to 1.5V in the ON state.

## **POWER TRANSISTORS**

Transistors which have high voltage and high current ratings are called power transistors. Power transistors used as switching elements, are operated in saturation region resulting in a low - on state voltage drop. Switching speed of transistors are much higher than the thyristors. and they are extensively used in dc-dc and dc-ac converters with inverse parallel connected diodes to provide bi-directional current flow. However, voltage and current ratings of power transistor are much lower than the thyristors. Transistors are used in low to medium power applications. Transistors are current controlled device and to keep it in the conducting state, a continuous base current is required.

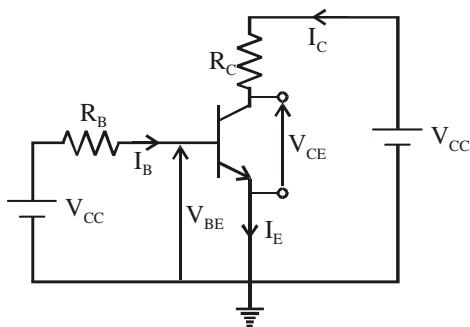
Power transistors are classified as follows

- Bi-Polar Junction Transistors (BJTs)
- Metal-Oxide Semi-Conductor Field Effect Transistors (MOSFETs)
- Insulated Gate Bi-Polar Transistors (IGBTs)
- Static Induction Transistors (SITs)

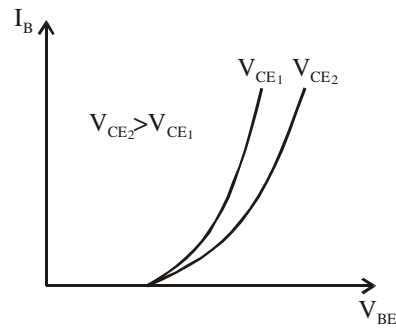
## **BI-POLAR JUNCTION TRANSISTOR**

A Bi-Polar Junction Transistor is a 3 layer, 3 terminals device. The 3 terminals are base, emitter and collector. It has 2 junctions' collector-base junction (CB) and emitter-base junction (EB). Transistors are of 2 types, NPN and PNP transistors.

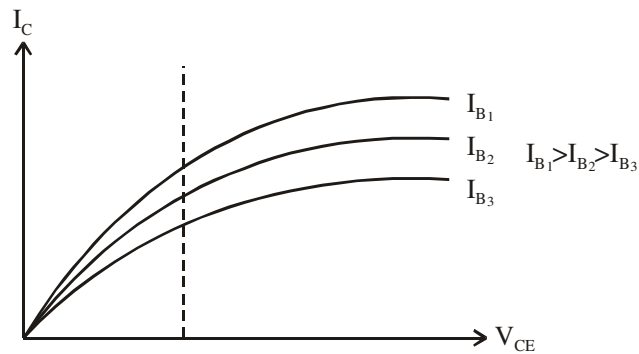
The different configurations are common base, common collector and common emitter. Common emitter configuration is generally used in switching applications.



**Fig: NPN Transistor**



**Fig: Input Characteristic**



**Fig: Output / Collector Characteristics**

Transistors can be operated in 3 regions i.e., cut-off, active and saturation.

In the cut-off region transistor is OFF, both junctions (EB and CB) are reverse biased. In the cut-off state the transistor acts as an open switch between the collector and emitter.

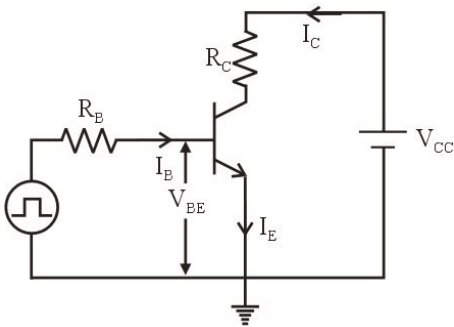
In the active region, transistor acts as an amplifier (CB junction is reverse biased and EB junction is forward biased),

In saturation region the transistor acts as a closed switch and both the junctions CB and EB are forward biased.

### SWITCHING CHARACTERISTICS

An important application of transistor is in switching circuits. When transistor is used as a switch it is operated either in cut-off state or in saturation state. When the transistor is driven into the cut-off state it operates in the non-conducting state. When the transistor is operated in saturation state it is in the conduction state.

Thus the non-conduction state is operation in the cut-off region while the conducting state is operation in the saturation region.



**Fig: Switching Transistor in CE Configuration**

As the base voltage  $V_B$  rises from 0 to  $V_B$ , the base current rises to  $I_B$ , but the collector current does not rise immediately. Collector current will begin to increase only when the base emitter junction is forward biased and  $V_{BE} > 0.6V$ . The collector current  $I_C$  will gradually increase towards saturation level  $I_{C(sat)}$ . The time required for the collector current to rise to 10% of its final value is called delay time  $t_d$ . The time taken by the collector current to rise from 10% to 90% of its final value is called rise time  $t_r$ . Turn on times is sum of  $t_d$  and  $t_r$ .

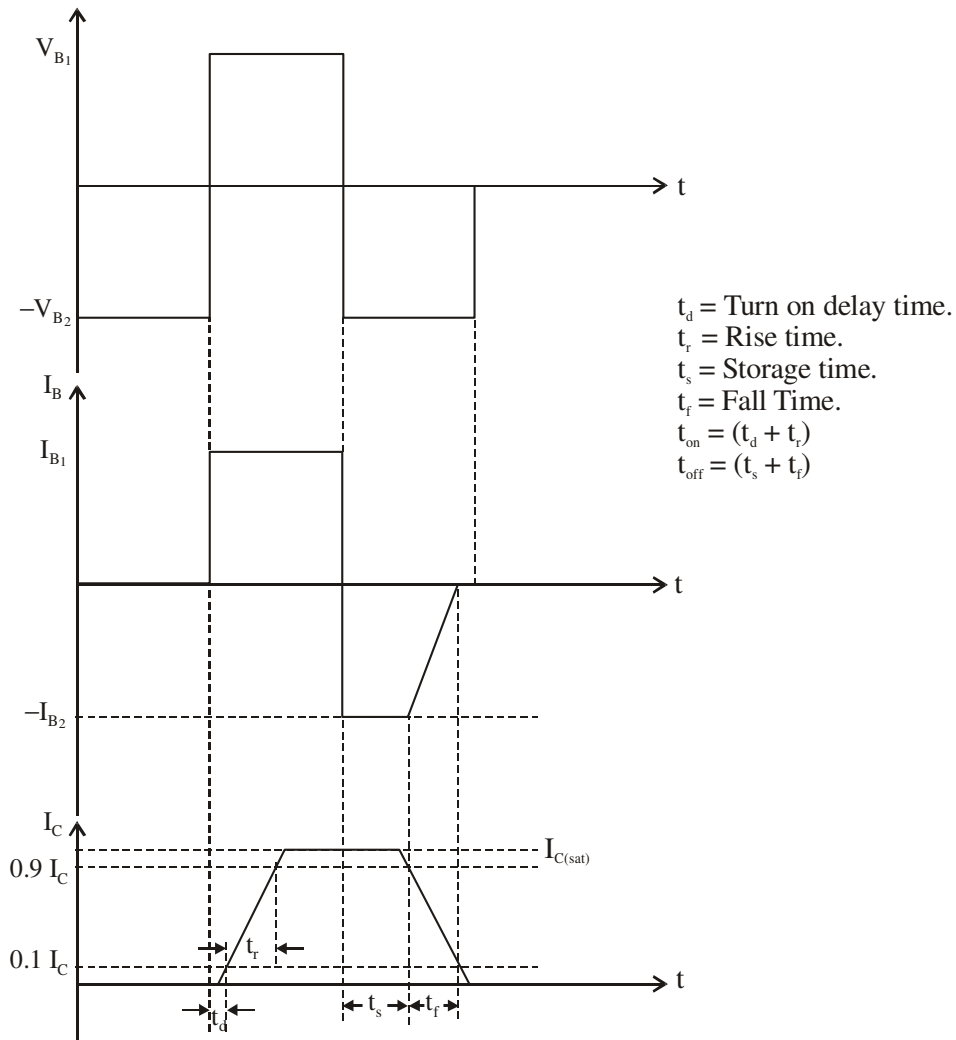
$$t_{on} = t_d + t_r$$

The turn-on time depends on

- Transistor junction capacitances which prevent the transistors voltages from changing instantaneously.
- Time required for emitter current to diffuse across the base region into the collector region once the base emitter junction is forward biased. The turn on time  $t_{on}$  ranges from 10 to 300 ns. Base current is normally more than the minimum required to saturate the transistor. As a result excess minority carrier charge is stored in the base region.

When the input voltage is reversed from  $V_{B1}$  to  $-V_{B2}$  the base current also abruptly changes but the collector current remains constant for a short time interval  $t_s$  called the storage time.

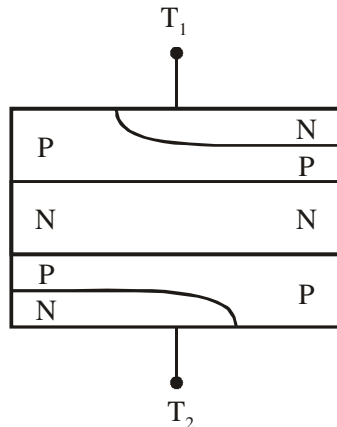
The reverse base current helps to discharge the minority charge carries in the base region and to remove the excess stored charge form the base region. Once the excess stored charge is removed the baser region the base current begins to fall towards zero. The fall-time  $t_f$  is the time taken for the collector current to fall from 90% to 10% of  $I_{C(sat)}$ . The turn off time  $t_{off}$  is the sum of storage time and the fall time.  $t_{off} = t_s + t_f$



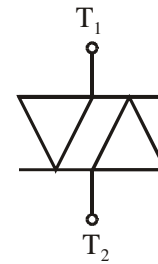
**Fig: Switching Times of Bipolar Junction Transistor**

## DIAC

A diac is a two terminal five layer semi-conductor bi-directional switching device. It can conduct in both directions. The device consists of two p-n-p-n sections in anti parallel as shown in figure.  $T_1$  and  $T_2$  are the two terminals of the device.

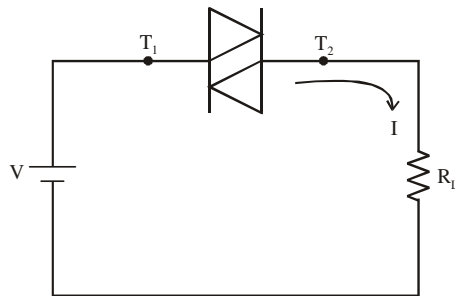


**Fig.: Diac Structure**

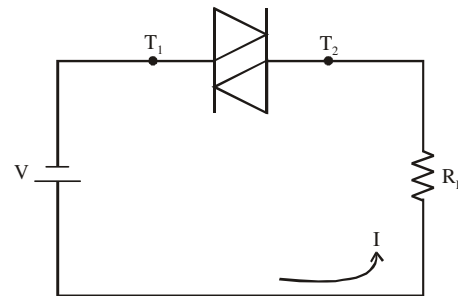


**Fig.: Diac symbol**

Figure above shows the symbol of diac. Diac will conduct when the voltage applied across the device terminals  $T_1$  &  $T_2$  exceeds the break over voltage..



**Fig. 1.1**



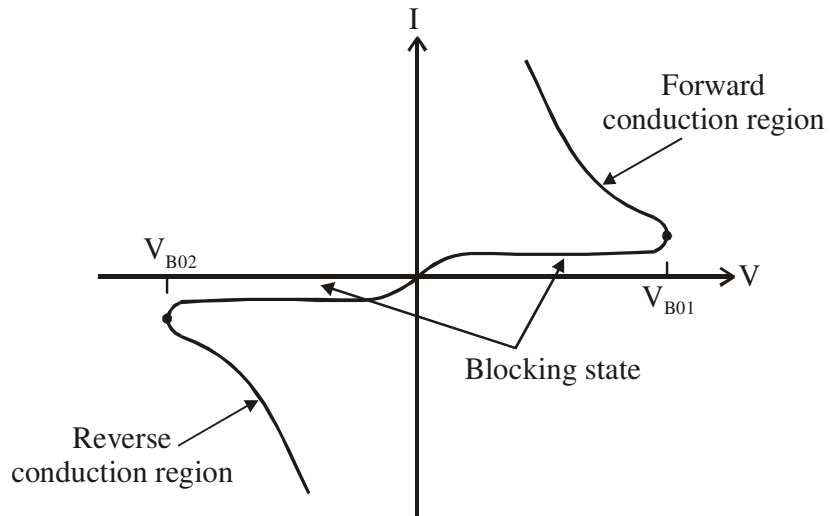
**Fig. 1.2**

Figure 1.1 shows the circuit diagram with  $T_1$  positive with respect to  $T_2$ . When the voltage across the device is less than the break over voltage  $V_{B01}$  a very small amount of current called leakage current flows through the device. During this period the device is in non-conducting or blocking mode. But once the voltage across the diac exceeds the break over voltage  $V_{B01}$  the diac turns on and begins to conduct. Once it starts conducting the current through diac becomes large and the device current has to be limited by connecting an external load resistance  $R_L$ , at the same time the voltage across the diac decreases in the conduction state. This explain the forward characteristics.

Figure 1.2 shows the circuit diagram with  $T_2$  positive with respect to  $T_1$ . The reverse characteristics obtained by varying the supply voltage are identical with the forward characteristic as the device construction is symmetrical in both the directions.

In both the cases the diac exhibits negative resistance switching characteristic during conduction. i.e., current flowing through the device increases whereas the voltage across it decreases.

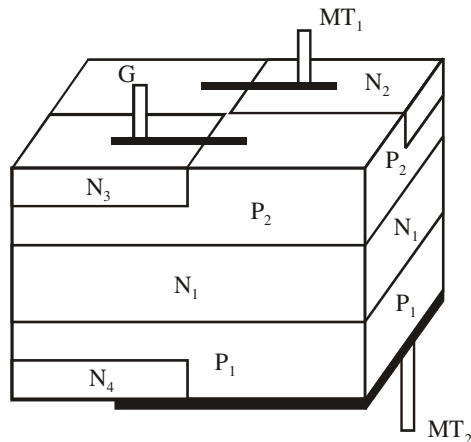
Figure below shows forward and reverse characteristics of a diac. Diac is mainly used for triggering triacs.



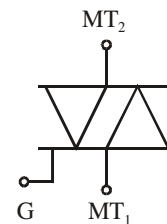
**Fig.: Diac Characteristics**

**TRIAC**

A triac is a three terminal bi-directional switching thyristor device. It can conduct in both directions when it is triggered into the conduction state. The triac is equivalent to two SCRs connected in anti-parallel with a common gate. Figure below shows the triac structure. It consists of three terminals viz.,  $MT_2$ ,  $MT_1$  and gate G.



**Fig. : Triac Structure**



**Fig. : Triac Symbol**

The gate terminal G is near the  $MT_1$  terminal. Figure above shows the triac symbol.  $MT_1$  is the reference terminal to obtain the characteristics of the triac. A triac can

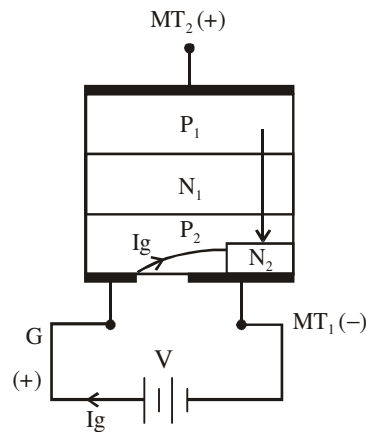
be operated in four different modes depending upon the polarity of the voltage on the terminal  $MT_2$  with respect to  $MT_1$  and based on the gate current polarity.

The characteristics of a triac is similar to that of an SCR, both in blocking and conducting states. A SCR can conduct in only one direction whereas triac can conduct in both directions.

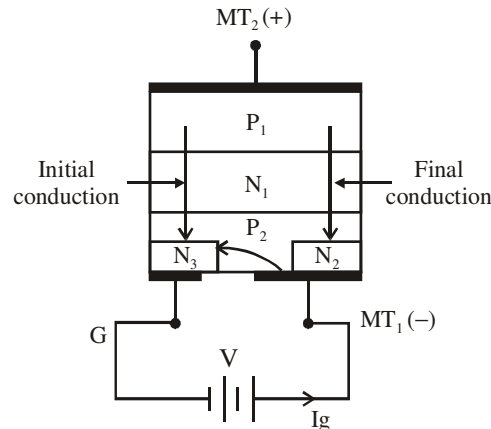
### TRIGGERING MODES OF TRIAC

#### MODE 1 : $MT_2$ positive, Positive gate current ( $I^+$ mode of operation)

When  $MT_2$  and gate current are positive with respect to  $MT_1$ , the gate current flows through  $P_2$ - $N_2$  junction as shown in figure below. The junction  $P_1$ - $N_1$  and  $P_2$ - $N_2$  are forward biased but junction  $N_1$ - $P_2$  is reverse biased. When sufficient number of charge carriers are injected in  $P_2$  layer by the gate current the junction  $N_1$ - $P_2$  breakdown and triac starts conducting through  $P_1N_1P_2N_2$  layers. Once triac starts conducting the current increases and its V-I characteristics is similar to that of thyristor. Triac in this mode operates in the first-quadrant.



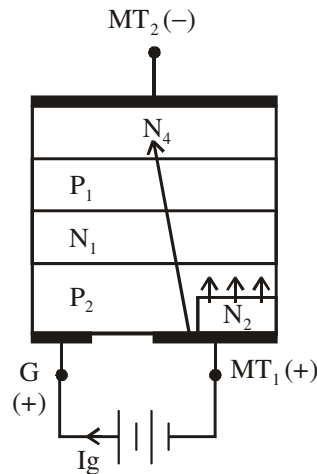
#### MODE 2 : $MT_2$ positive, Negative gate current ( $I^-$ mode of operation)



When  $MT_2$  is positive and gate  $G$  is negative with respect to  $MT_1$  the gate current flows through  $P_2-N_3$  junction as shown in figure above. The junction  $P_1-N_1$  and  $P_2-N_3$  are forward biased but junction  $N_1-P_2$  is reverse biased. Hence, the triac initially starts conducting through  $P_1N_1P_2N_3$  layers. As a result the potential of layer between  $P_2-N_3$  rises towards the potential of  $MT_2$ . Thus, a potential gradient exists across the layer  $P_2$  with left hand region at a higher potential than the right hand region. This results in a current flow in  $P_2$  layer from left to right, forward biasing the  $P_2N_2$  junction. Now the right hand portion  $P_1-N_1 - P_2-N_2$  starts conducting. The device operates in first quadrant. When compared to Mode 1, triac with  $MT_2$  positive and negative gate current is less sensitive and therefore requires higher gate current for triggering.

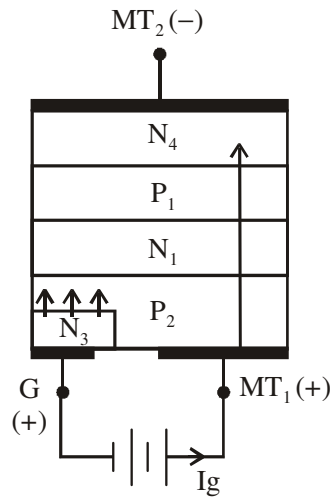
**MODE 3 :  $MT_2$  negative, Positive gate current ( $III^+$  mode of operation)**

When  $MT_2$  is negative and gate is positive with respect to  $MT_1$  junction  $P_2N_2$  is forward biased and junction  $P_1-N_1$  is reverse biased.  $N_2$  layer injects electrons into  $P_2$  layer as shown by arrows in figure below. This causes an increase in current flow through junction  $P_2-N_1$ . Resulting in breakdown of reverse biased junction  $N_1-P_1$ . Now the device conducts through layers  $P_2N_1P_1N_4$  and the current starts increasing, which is limited by an external load.



The device operates in third quadrant in this mode. Triac in this mode is less sensitive and requires higher gate current for triggering.

**MODE 4 :  $MT_2$  negative, Negative gate current ( $III^-$  mode of operation)**



In this mode both  $MT_2$  and gate G are negative with respect to  $MT_1$ , the gate current flows through  $P_2N_3$  junction as shown in figure above. Layer  $N_3$  injects electrons as shown by arrows into  $P_2$  layer. This results in increase in current flow across  $P_1N_1$  and the device will turn ON due to increased current in layer  $N_1$ . The current flows through layers  $P_2N_1P_1N_4$ . Triac is more sensitive in this mode compared to turn ON with positive gate current. (Mode 3).

Triac sensitivity is greatest in the first quadrant when turned ON with positive gate current and also in third quadrant when turned ON with negative gate current. when  $MT_2$  is positive with respect to  $MT_1$  it is recommended to turn on the triac by a positive gate current. When  $MT_2$  is negative with respect to  $MT_1$  it is recommended to turn on the triac by negative gate current. Therefore Mode 1 and Mode 4 are the preferred modes of operation of a triac ( $I^+$  mode and  $III^-$  mode of operation are normally used).

**TRIAC CHARACTERISTICS**

Figure below shows the circuit to obtain the characteristics of a triac. To obtain the characteristics in the third quadrant the supply to gate and between  $MT_2$  and  $MT_1$  are reversed.

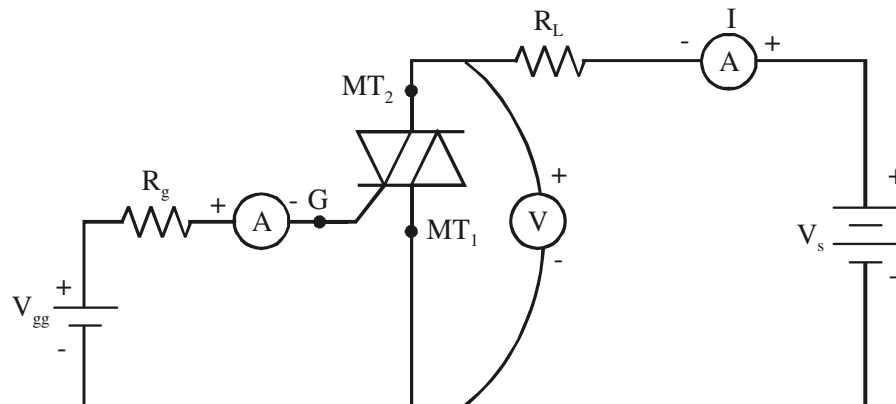
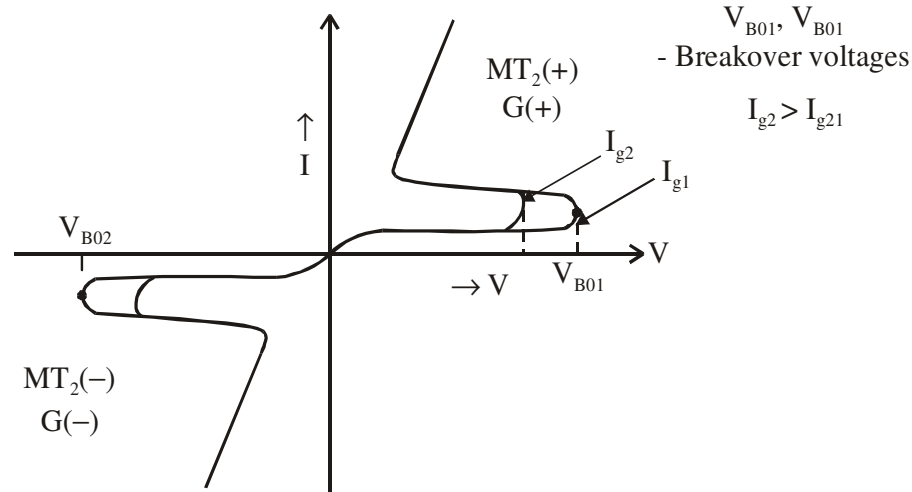


Figure below shows the V-I Characteristics of a triac. Triac is a bidirectional switching device. Hence its characteristics are identical in the first and third quadrant. When gate current is increased the break over voltage decreases.



**Fig.: Triac Characteristic**

Triac is widely used to control the speed of single phase induction motors. It is also used in domestic lamp dimmers and heat control circuits, and full wave AC voltage controllers.

### POWER MOSFET

Power MOSFET is a metal oxide semiconductor field effect transistor. It is a voltage controlled device requiring a small input gate voltage. It has high input impedance. MOSFET is operated in two states viz., ON STATE and OFF STATE. Switching speed of MOSFET is very high. Switching time is of the order of nanoseconds.

MOSFETs are of two types

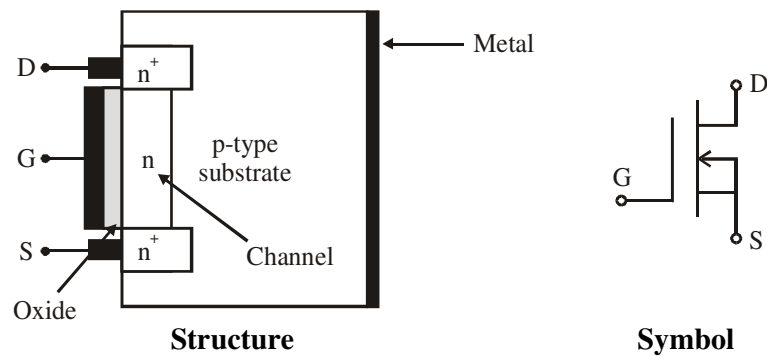
- Depletion MOSFETs
- Enhancement MOSFETs.

MOSFET is a three terminal device. The three terminals are gate (G), drain (D) and source (S).

### DEPLETION MOSFET

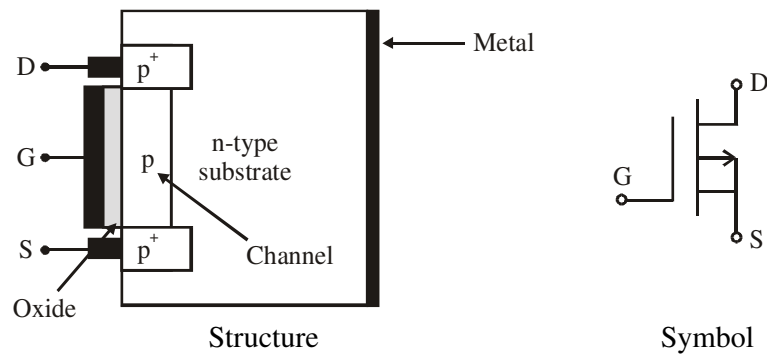
Depletion type MOSFET can be either a n-channel or p-channel depletion type MOSFET.

A depletion type n-channel MOSFET consists of a p-type silicon substrate with two highly doped n<sup>+</sup> silicon for low resistance connections. A n-channel is diffused between drain and source. Figure below shows a n-channel depletion type MOSFET. Gate is isolated from the channel by a thin silicon dioxide layer.



**Fig. : n-channel depletion type MOSFET**

Gate to source voltage ( $V_{GS}$ ) can be either positive or negative. If  $V_{GS}$  is negative, electrons present in the n-channel are repelled leaving positive ions. This creates a depletion.

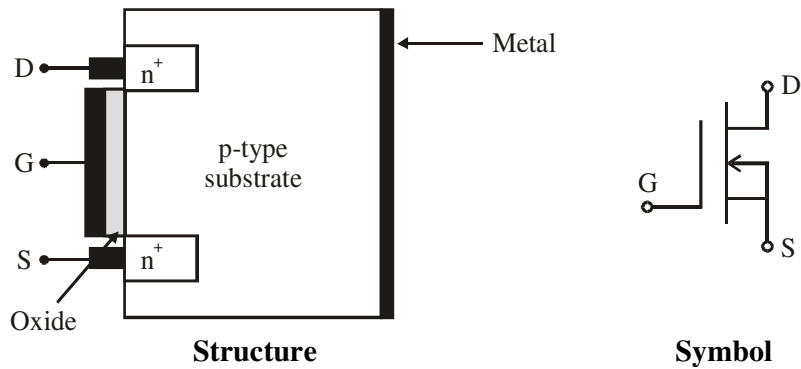


**Fig. : P-channel depletion type MOSFET**

Figure above shows a p-channel depletion type MOSFET. A P-channel depletion type MOSFET consists of a n-type substrate into which highly doped p-regions and a P-channel are diffused. The two P+ regions act as drain and source P-channel operation is same except that the polarities of voltages are opposite to that of n-channel.

### ENHANCEMENT MOSFET

Enhancement type MOSFET has no physical channel. Enhancement type MOSFET can be either a n-channel or p-channel enhancement type MOSFET.

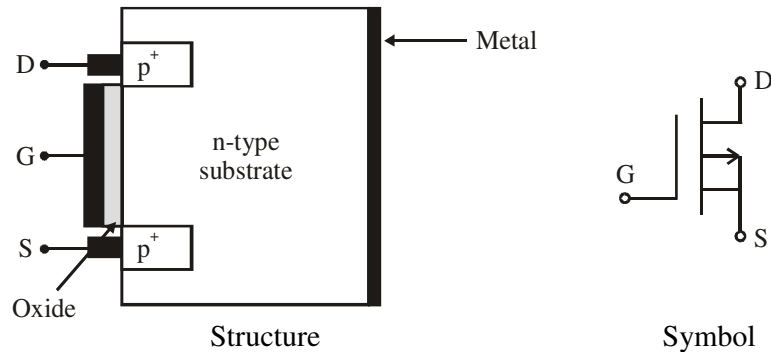


**Fig. : n-channel enhancement type MOSFET**

Figure above shows a n-channel enhancement type MOSFET. The P-substrate extends upto the silicon dioxide layer. The two highly doped n regions act as drain and source.

When gate is positive ( $V_{GS}$ ) free electrons are attracted from P-substrate and they collect near the oxide layer. When gate to source voltage,  $V_{GS}$  becomes greater than or equal to a value called threshold voltage ( $V_T$ ). Sufficient numbers of electrons are accumulated to form a virtual n-channel and current flows from drain to source.

Figure below shows a p-channel enhancement type of MOSFET. The n-substrate extends upto the silicon dioxide layer. The two highly doped P regions act as drain and source. For p-channel the polarities of voltages are opposite to that of n-channel.

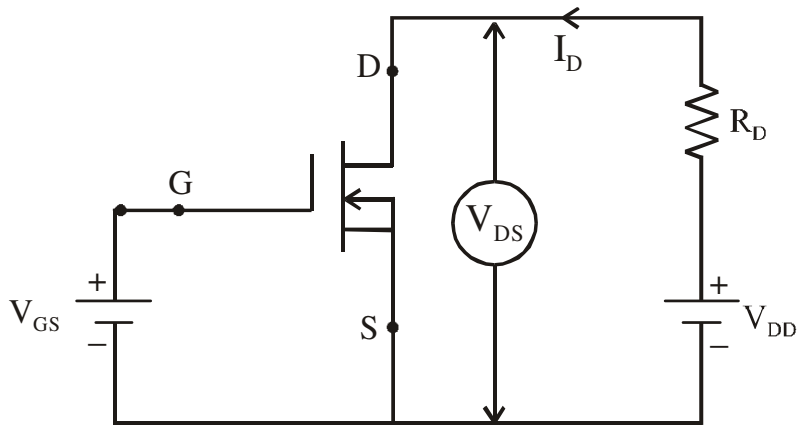


**Fig. : P-channel enhancement type MOSFET.**

## CHARACTERISTICS OF MOSFET

### Depletion MOSFET

Figure below shows n-channel depletion type MOSFET with gate positive with respect to source.  $I_D$ ,  $V_{DS}$  and  $V_{GS}$  are drain current, drain source voltage and gate-source voltage. A plot of variation of  $I_D$  with  $V_{DS}$  for a given value of  $V_{GS}$  gives the Drain characteristics or Output characteristics.



**Fig: n-channel Depletion MOSFET**

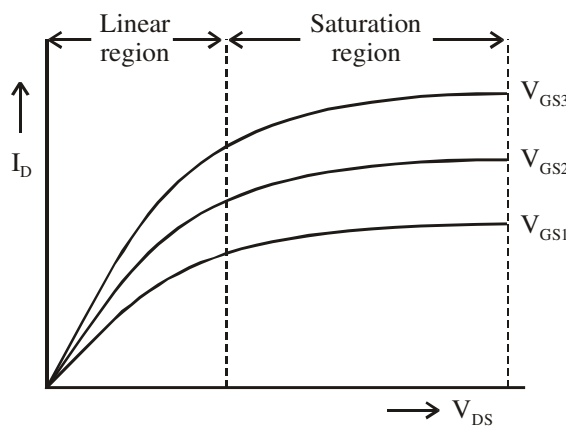
**n-channel Depletion type MOSFET**

$V_{GS}$  &  $V_{DS}$  are positive.  $I_D$  is positive for n channel MOSFET.  $V_{GS}$  is negative for depletion mode.  $V_{GS}$  is positive for enhancement mode.

Figure below shows the drain characteristic. MOSFET can be operated in three regions

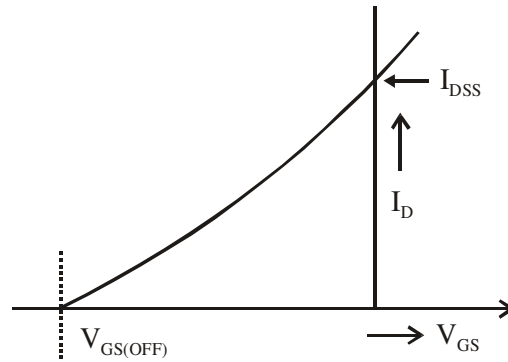
- Cut-off region,
- Saturation region (pinch-off region) and
- Linear region.

In the linear region  $I_D$  varies linearly with  $V_{DS}$ . i.e., increases with increase in  $V_{DS}$ . Power MOSFETs are operated in the linear region for switching actions. In saturation region  $I_D$  almost remains constant for any increase in  $V_{DS}$ .



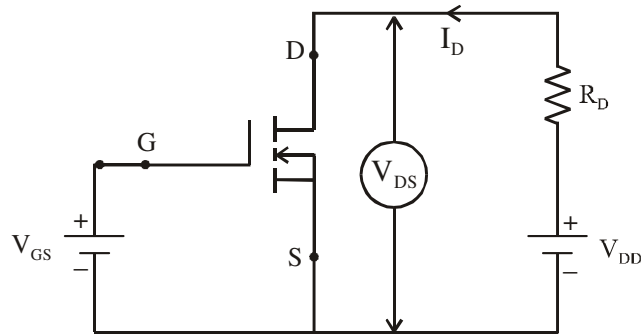
**Fig.: Drain Characteristic**

Figure below shows the transfer characteristic. Transfer characteristic gives the variation of  $I_D$  with  $V_{GS}$  for a given value of  $V_{DS}$ .  $I_{DSS}$  is the drain current with shorted gate. As curve extends on both sides  $V_{GS}$  can be negative as well as positive.



**Fig.: Transfer characteristic**

**Enhancement MOSFET**

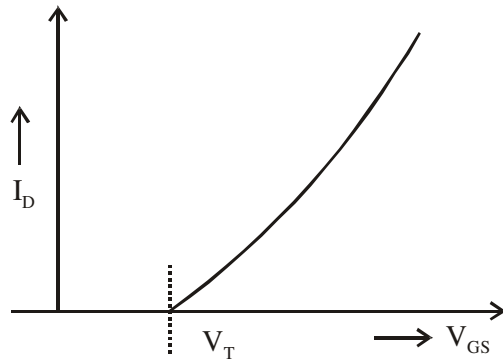


**Fig: n-channel Enhancement MOSFET**

**Enhancement type MOSFET**

$V_{GS}$  is positive for a n-channel enhancement MOSFET.  $V_{DS}$  &  $I_D$  are also positive for n channel enhancement MOSFET

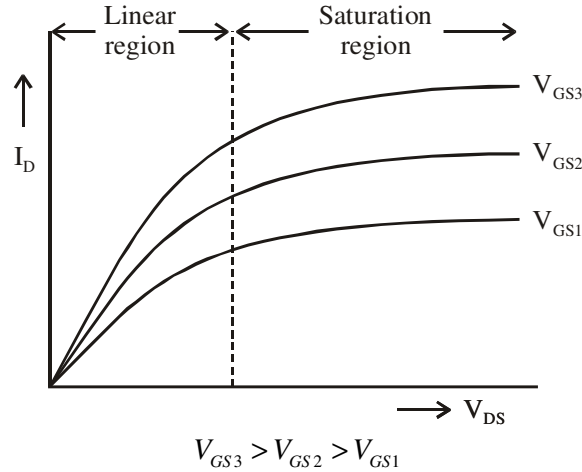
Figure above shows circuit to obtain characteristic of n channel enhancement type MOSFET. Figure below shows the drain characteristic. Drain characteristic gives the variation of  $I_D$  with  $V_{DS}$  for a given value of  $V_{GS}$ .



$V_T = V_{GS(TH)} = \text{Gate Source Threshold Voltage}$

**Fig.: Transfer Characteristic**

Figure below shows the transfer characteristic which gives the variation of  $I_D$  with  $V_{GS}$  for a given value of  $V_{DS}$ .



**Fig. : Drain Characteristic**

### MOSFET PARAMETERS

The parameters of MOSFET can be obtained from the graph as follows.

$$\text{Mutual Transconductance } g_m = \frac{\Delta I_D}{\Delta V_{GS}} \bigg/ V_{DS} = \text{Constant}$$

$$\text{Output or Drain Resistance } R_{ds} = \frac{\Delta V_{DS}}{\Delta I_D} \bigg/ V_{GS} = \text{Constant}$$

$$\text{Amplification factor } \mu = R_{ds} \times g_m$$

Power MOSFETs are generally of enhancement type. Power MOSFETs are used in switched mode power supplies.

Power MOSFET's are used in high speed power converters and are available at a relatively low power rating in the range of 1000V, 50A at a frequency range of several tens of KHz ( $f_{\max} = 100\text{KHz}$ ).

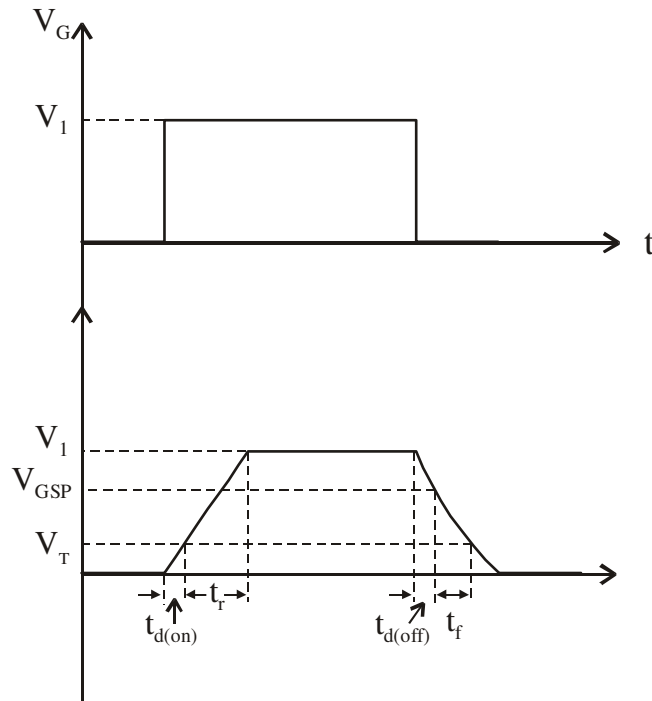
### SWITCHING CHARACTERISTICS OF MOSFET

Power MOSFETs are often used as switching devices. The switching characteristic of a power MOSFET depends on the capacitances between gate to source  $C_{GS}$ , gate to drain  $C_{GD}$  and drain to source  $C_{DS}$ . It also depends on the impedance of the gate drive circuit. During turn-on there is a turn-on delay  $t_{d(on)}$ , which is the time required for the input capacitance  $C_{GS}$  to charge to threshold voltage level  $V_T$ . During the rise time  $t_r$ ,  $C_{GS}$  charges to full gate voltage  $V_{GSP}$  and the device operate in the linear

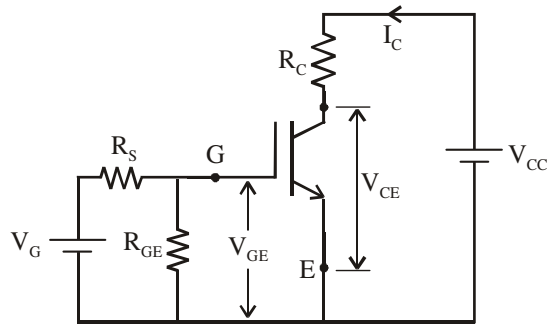
region (ON state). During rise time  $t_r$  drain current  $I_D$  rises from zero to full on state current  $I_D$ .

- Total turn-on time,  $t_{on} = t_{d(on)} + t_r$

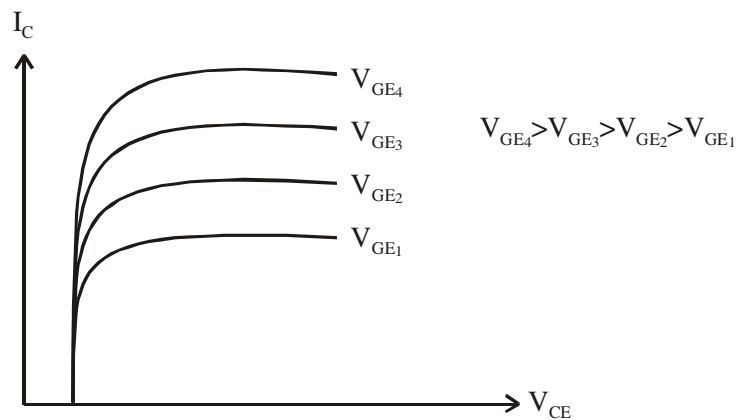
MOSFET can be turned off by discharging capacitance  $C_{GS}$ .  $t_{d(off)}$  is the turn-off delay time required for input capacitance  $C_{GS}$  to discharge from  $V_1$  to  $V_{GSP}$ . Fall time  $t_f$  is the time required for input capacitance to discharge from  $V_{GSP}$  to threshold voltage  $V_T$ . During fall time  $t_f$  drain current falls from  $I_D$  to zero. Figure below shows the switching waveforms of power MOSFET.







**Fig.: Circuit Diagram to Obtain Characteristics**



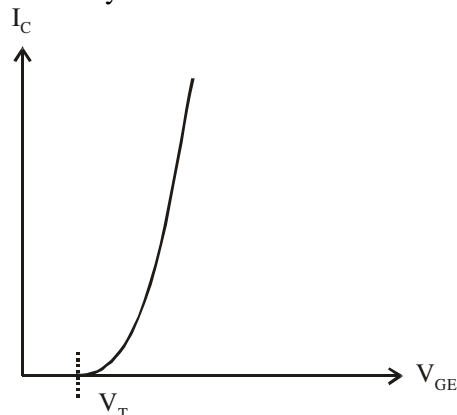
**Fig. : Output Characteristics**

A plot of collector current  $I_C$  versus gate-emitter voltage  $V_{GE}$  for a given value of  $V_{CE}$  gives the transfer characteristic. Figure below shows the transfer characteristic.

**Note**

Controlling parameter is the gate-emitter voltage  $V_{GE}$  in IGBT. If  $V_{GE}$  is less than the threshold voltage  $V_T$  then IGBT is in OFF state. If  $V_{GE}$  is greater than the threshold voltage  $V_T$  then the IGBT is in ON state.

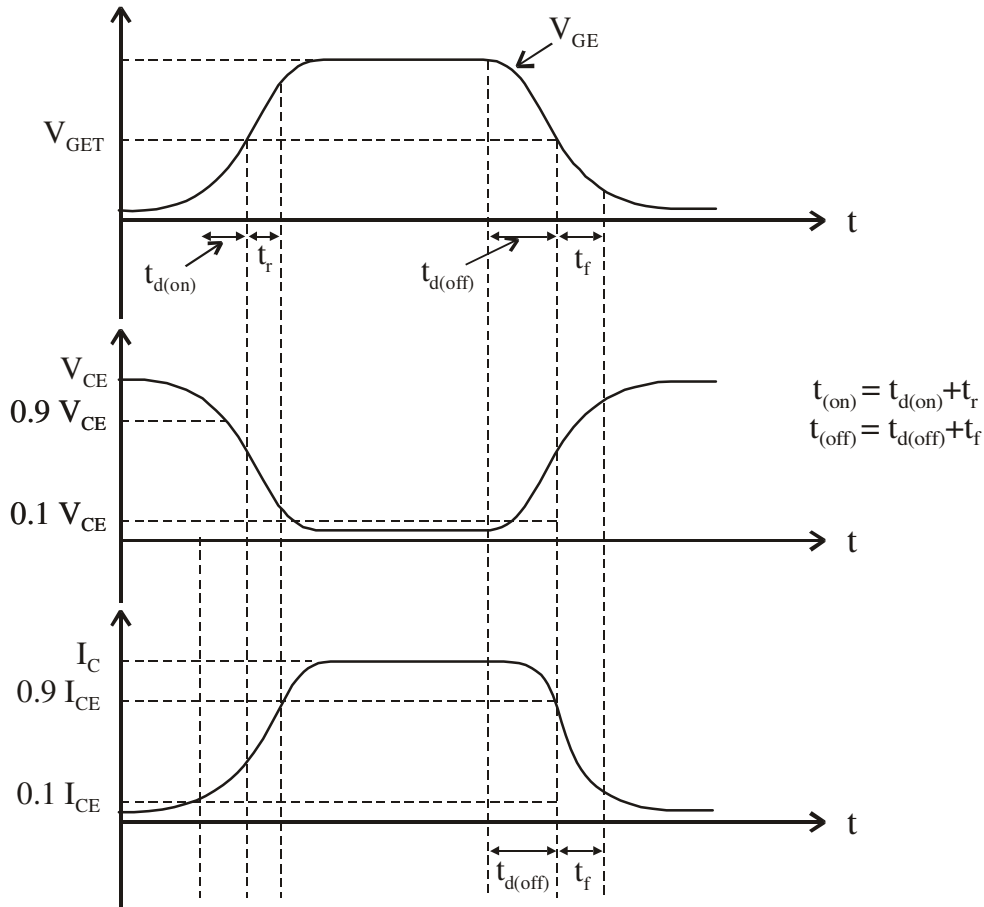
IGBTs are used in medium power applications such as ac and dc motor drives, power supplies and solid state relays.



**Fig. : Transfer Characteristic**

## SWITCHING CHARACTERISTIC OF IGBT

Figure below shows the switching characteristic of an IGBT. Turn-on time consists of delay time  $t_{d(on)}$  and rise time  $t_r$ .



**Fig. : Switching Characteristics**

The turn on delay time is the time required by the leakage current  $I_{CE}$  to rise to  $0.1 I_C$ , where  $I_C$  is the final value of collector current. Rise time is the time required for collector current to rise from  $0.1 I_C$  to its final value  $I_C$ . After turn-on collector-emitter voltage  $V_{CE}$  will be very small during the steady state conduction of the device.

The turn-off time consists of delay off time  $t_{d(off)}$  and fall time  $t_f$ . Off time delay is the time during which collector current falls from  $I_C$  to  $0.9 I_C$  and  $V_{GE}$  falls to threshold voltage  $V_{GET}$ . During the fall time  $t_f$  the collector current falls from  $0.9 I_C$  to  $0.1 I_C$ . During the turn-off time interval collector-emitter voltage rises to its final value  $V_{CE}$ .

IGBT's are voltage controlled power transistor. They are faster than BJT's, but still not quite as fast as MOSFET's. The IGBT's offer superior drive and output characteristics when compared to BJT's. IGBT's are suitable for high voltage, high current and frequencies up to 20KHz. IGBT's are available up to 1400V, 600A and 1200V, 1000A



## IGBT APPLICATIONS

Medium power applications like DC and AC motor drives, medium power supplies, solid state relays and contractors, general purpose inverters, UPS, welder equipments, servo controls, robotics, cutting tools, induction heating

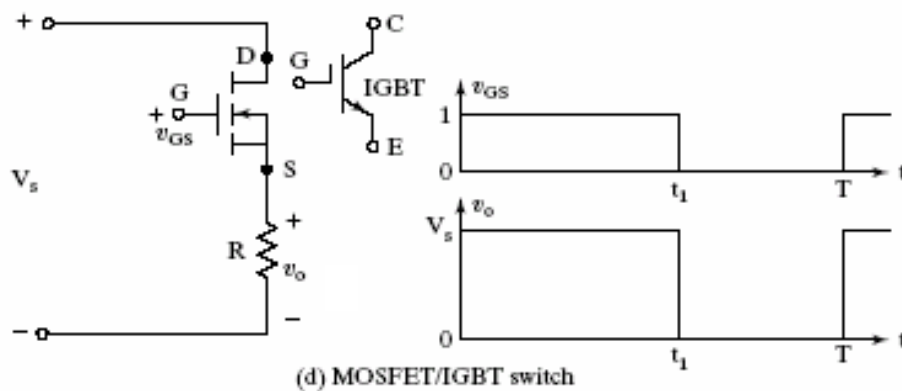
## TYPICAL RATINGS OF IGBT

Voltage rating = 1400V. Current rating = 600A. Maximum operating frequency = 20KHZ. Switching time  $\approx 2.3\mu s$  ( $t_{ON} \approx t_{OFF}$ ). ON state resistance =  $600m\Omega = 60 \times 10^{-3}\Omega$ .

## POWER MOSFET RATINGS

Voltage rating = 500V. Current rating = 50A. Maximum operating frequency = 100KHZ. Switching time  $\approx 0.6\mu s$  to  $1\mu s$  ( $t_{ON} \approx t_{OFF}$ ). ON state resistance  $R_{D(ON)} = 0.4m\Omega$  to  $0.6m\Omega$ .

## A MOSFET/IGBT SWITCH



MOSFET / IGBT can be used as a switch in the circuit shown above. If a n-channel enhancement MOSFET is used then the input pulse is  $V_{GS}$  which is the pulse applied between gate and source, which is a positive going voltage pulse.

## IGBT's

Minority carrier devices, superior conduction characteristics, ease of drive, wide SOA, peak current capability and ruggedness. Generally the switching speed of an IGBT is inferior to that of a power MOSFET.

## POWER MOSFET'S (MAJORITY CARRIER DEVICES)

Higher switching speed, peak current capability, ease of drive, wide SOA, avalanche and  $\frac{d_v}{d_t}$  capability have made power MOSFET is the ideal choice in new power electronic circuit designs.

## IGBT (INSULATED GATE BIPOLAR TRANSISTORS) FEATURES

IGBT combines the advantages of BJT's and MOSFET's. Features of IGBT are

- IGBT has high input impedance like MOSFET's.
- Low ON state conduction power losses like BJT's.
- There is no secondary breakdown problem like BJT's.
- By chip design and structure design, the equivalent drain to source resistance  $R_{DS}$  is controlled to behave like that of BJT.

## DATA SHEET DETAILS OF THE IGBT MODULE CM400HA-24H

High power switching device by Mitsubishi Semiconductors Company  
 $I_C = 400A$ ,  $V_{CES} = 1200V$ .

## APPLICATIONS OF IGBT CM400HA-24H

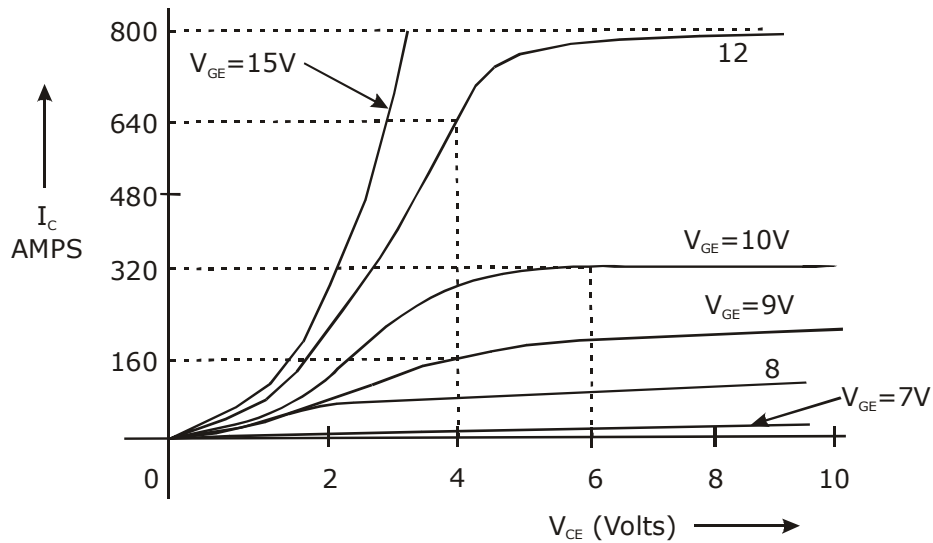
AC and DC motor controls, general purpose inverters, UPS, welders, servo controls, numeric control, robotics, cutting tools, induction heating.

## MAXIMUM RATINGS

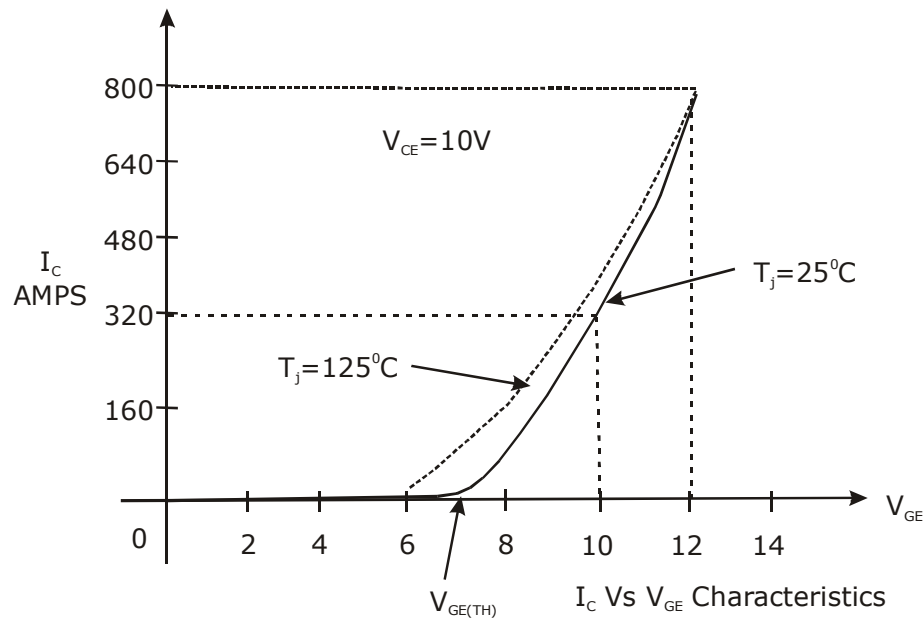
$V_{CES}$	Collector-Emitter (G-E short) voltage	1200V
$V_{GES}$	Gate-Emitter (C-E short) voltage	$\pm 20V$ .
$I_C$	Collector Current (steady / average current)	400A, at $T_C = 25^0 C$ .
$I_{CM}$	Pulsed Collector Current	800A
$I_E$	Emitter Current	400A, at $T_C = 25^0 C$ .
$I_{EM}$	Maximum Pulsed Emitter Current	800A
$P_{C(max)}$	Maximum Collector Power Dissipation	2800W, at $T_C = 25^0 C$ .
$T_{storage}$	Maximum Storage Temperature	$-40^0 c$ to $125^0 c$
$T_j$	Junction Temperature	$-40^0 c$ to $150^0 c$
	Weight Typical Value	400gm (0.4Kg)
	Electrical Characteristics	$T_j = 25^0 c$
	$V_{GE(th)} = V_{TH} =$ Gate – Emitter Threshold Voltage.	$V_{GE(th)} = 6V (Typ)$ .
	$V_{GE(th)} = 4.5V$ (min) to $7.5V$ maximum at $I_C = 40mA$ and $V_{CE} = 10V$ .	
$I_{CES}$	Collector cut-off current = 2mA (maximum) at $V_{CE} = V_{CES}$ , $V_{GE} = 0$	
$I_{GES}$	Gate leakage current = $0.5\mu A$ (maximum) at $V_{GE} = V_{GES}$ , $V_{CE} = 0$	
$V_{CE(sat)}$	Collector-Emitter saturation voltage ( $T_j = 25^0 C$ , $I_C = 400A$ , $V_{GE} = 15V$ )	
	$V_{CE(sat)}$ : 2.5V (typical), 3.5V (maximum)	
$t_{d(on)}$	Turn ON delay time 300nsec (maximum) at $V_{CC} = 600V$ , $I_C = 400A$ .	
$t_r$	Turn ON rise time 500nsec (maximum), at $V_{GE1} = V_{GE2} = 15V$ .	
	$t_{ON} = 800ns$ (max) = ( $t_d + t_r$ )	
$t_{d(OFF)}$	Turn off delay time = 350nsec.	

- $t_f$  Turn off fall time = 350nsec.
- $t_{OFF} = t_{d(OFF)} + t_f = 700nsec$  (maximum)
- $t_{rr}$  Reverse recovery time 250nsec.
- $Q_{rr}$  Reverse recovery charge = 2.97 $\mu$ c (typical).

**CHARACTERISTICS OF THE EMITTER TO COLLECTOR FWD CM 400HA-24H IGBT CHARACTERISTICS**



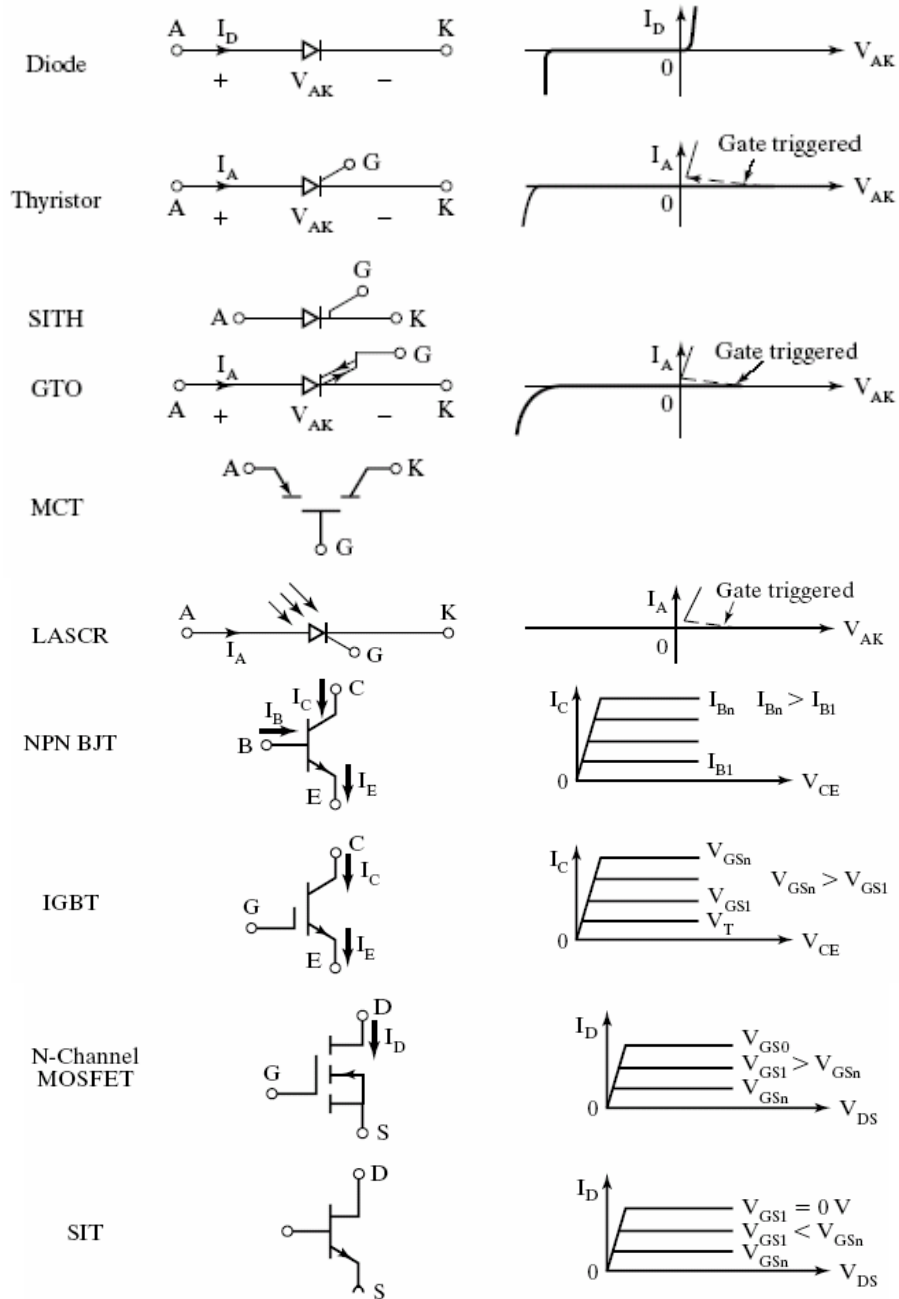
**Fig: Output Collector Characteristics**



**Fig: Transfer Characteristics**

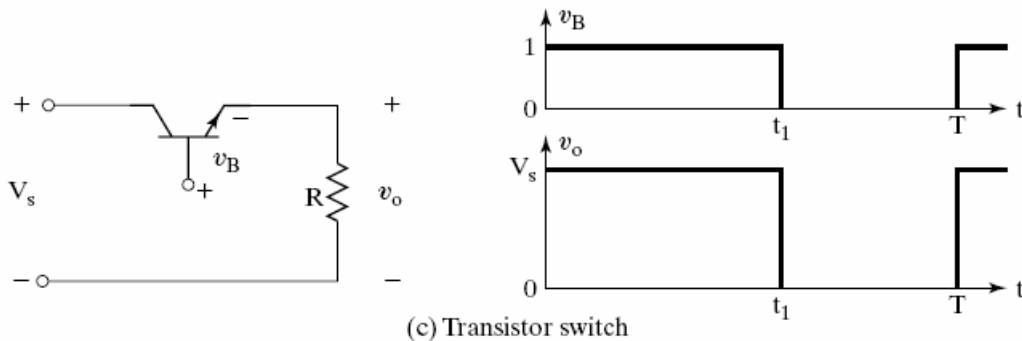
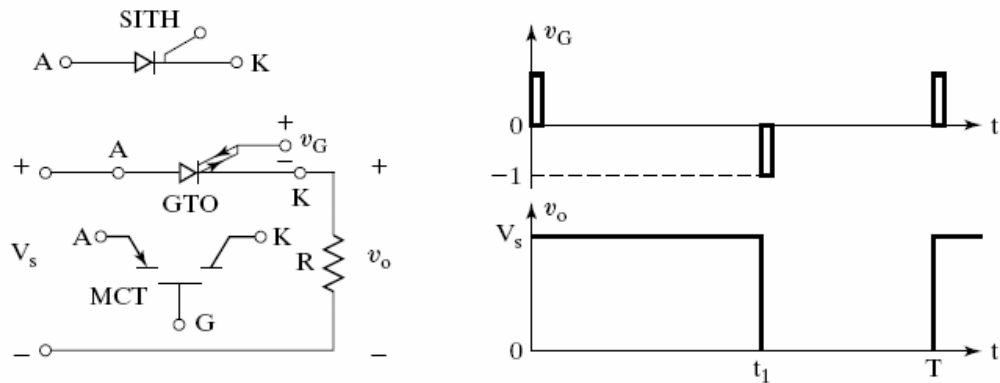
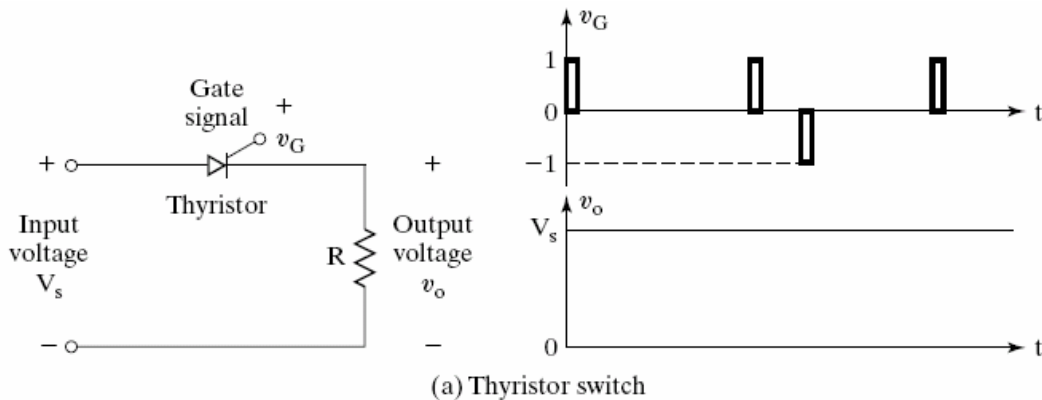


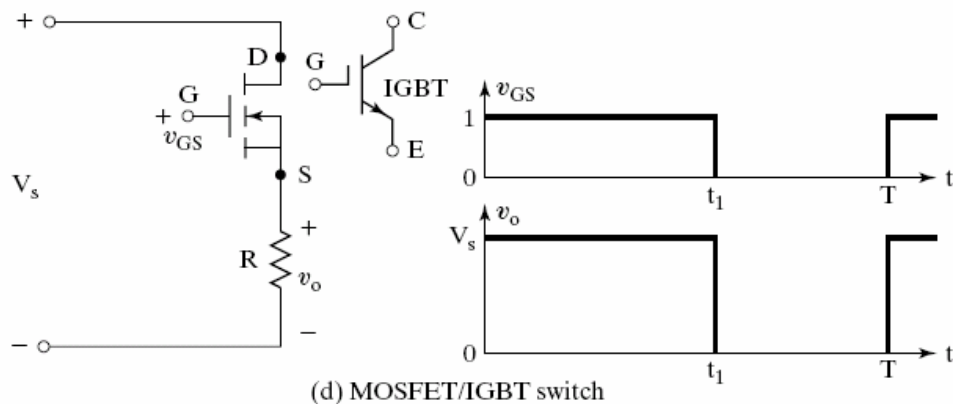
## POWER SEMICONDUCTOR DEVICES, THEIR SYMBOLS AND CHARACTERISTICS



## CONTROL CHARACTERISTICS OF POWER DEVICES

The power semiconductor devices can be operated as switches by applying control signals to the gate terminal of Thyristors (and to the base of bi-polar transistor). The required output is obtained by varying the conduction time of these switching devices. Figure below shows the output voltages and control characteristics of commonly used power switching devices. Once a thyristor is in a conduction mode, the gate signal of either positive or negative magnitude has no effect. When a power semiconductor device is in a normal conduction mode, there is a small voltage drop across the device. In the output voltage waveforms shown, these voltage drops are considered negligible.





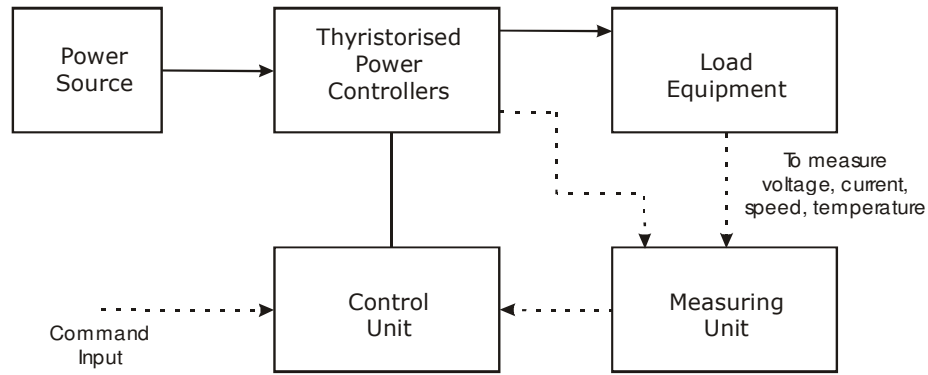
**Fig: Control Characteristics of Power Switching Devices**

The power semiconductor switching devices can be classified on the basis of

- Uncontrolled turn on and turn off (e.g.: diode).
- Controlled turn on and uncontrolled turn off (e.g. SCR)
- Controlled turn on and off characteristics (e.g. BJT, MOSFET, GTO, SITH, IGBT, SIT, MCT).
- Continuous gate signal requirement (e.g. BJT, MOSFET, IGBT, SIT).
- Pulse gate requirement (e.g. SCR, GTO, MCT).
- Bipolar voltage withstanding capability (e.g. SCR, GTO).
- Unipolar voltage withstanding capability (e.g. BJT, MOSFET, GTO, IGBT, MCT).
- Bidirectional current capability (e.g.: Triac, RCT).
- Unidirectional current capability (e.g. SCR, GTO, BJT, MOSFET, MCT, IGBT, SITH, SIT & Diode).

## THYRISTORISED POWER CONTROLLERS

Block diagram given below, shows the system employing a thyristorised power controller. The main power flow between the input power source and the load is shown by solid lines.



Thyristorised power controllers are widely used in the industry. Old/conventional controllers including magnetic amplifiers, mercury arc rectifiers, thyatrons, ignitrons, rotating amplifiers, resistance controllers have been replaced by thyristorised power controllers in almost all the applications.

A typical block diagram of a thyristorised power converter is shown in the above figure.

The thyristor power converter converts the available power from the source into a suitable form to run the load or the equipment. For example the load may be a DC motor drive which requires DC voltage for its operation. The available power supply is AC power supply as is often the case. The thyristor power converter used in this case is a AC to DC power converter which converts the input AC power into DC output voltage to feed to the DC motor. Very often a measuring unit or an instrumentation unit is used so as to measure and monitor the output parameters like the output voltage, the load current, the speed of the motor or the temperature etc. The measuring unit will be provided with meters and display devices so that the output parameters can be seen and noted. The control unit is employed to control the output of the thyristorised power converter so as to adjust the output voltage / current to the desired value to obtain optimum performance of the load or equipment. The signal from the control unit is used to adjust the phase angle / trigger angle of the Thyristors in the power controller so as to vary the output voltage to the desired value.

## SOME IMPORTANT APPLICATIONS OF THYRISTORISED POWER CONTROLLERS

- Control of AC and DC motor drives in rolling mills, paper and textile mills, traction vehicles, mine winders, cranes, excavators, rotary kilns, ventilation fans, compression etc.
- Uninterruptible and stand by power supplies for critical loads such as computers, special high tech power supplies for aircraft and space applications.
- Power control in metallurgical and chemical processes using arc welding, induction heating, melting, resistance heating, arc melting, electrolysis, etc.

- Static power compensators, transformer tap changers and static contactors for industrial power systems.
- Power conversion at the terminals of a HVDC transmission systems.
- High voltage supplies for electrostatic precipitators and x-ray generators.
- Illumination/light control for lighting in stages, theaters, homes and studios.
- Solid state power controllers for home/domestic appliances.

#### **ADVANTAGES OF THYRISTORISED POWER CONTROLLERS**

- High efficiency due to low losses in the Thyristors.
- Long life and reduced/minimal maintenance due to the absence of mechanical wear.
- Control equipments using Thyristors are compact in size.
- Easy and flexibility in operation due to digital controls.
- Faster dynamic response compared to the electro mechanical converters.
- Lower acoustic noise when compared to electro magnetic controllers, relays and contactors.

#### **DISADVANTAGES OF THYRISTORISED POWER CONTROLLERS**

- All the thyristorised power controllers generate harmonics (unwanted frequency components) due to the switching ON and OFF of the thyristors. These harmonics adversely affect the performance of the load connected to them. For example when the load are motors, there are additional power losses (harmonic power loss) torque harmonics, and increase in acoustic noise.
- The generated harmonics are injected into the supply lines and thus adversely affect the other loads/equipments connected to the supply lines.
- In some applications example: traction, there is interference with the commutation circuits due to the power supply line harmonics and due to electromagnetic radiation.
- The thyristorised AC to DC converters and AC to AC converters can operate at low power factor under some conditions.
- Special steps are then taken for correcting the line supply power factor (by installing PF improvement apparatus).
- The thyristorised power controllers have no short time over loading capacity and therefore they must be rated for maximum loading conditions. This leads to an increase in the cost of the equipment.
- Special protection circuits must be employed in thyristorised power controllers in order to protect and safe guard the expensive thyristor devices. This again adds to the system cost.

#### **TYPES OF POWER CONVERTERS or THYRISTORISED POWER CONTROLLERS**

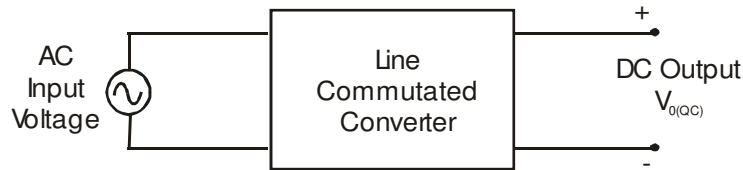
For the control of electric power supplied to the load or the equipment/machinery or for power conditioning the conversion of electric power from one form to other is necessary and the switching characteristic of power semiconductor devices (Thyristors) facilitate these conversions

The thyristorised power converters are referred to as the static power converters and they perform the function of power conversion by converting the available input power supply in to output power of desired form.

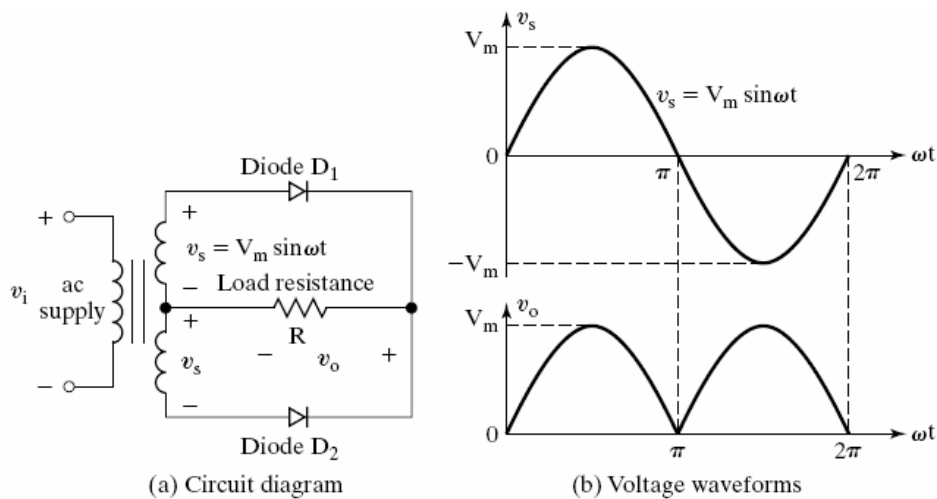
The different types of thyristor power converters are

- Diode rectifiers (uncontrolled rectifiers).
- Line commutated converters or AC to DC converters (controlled rectifiers)
- AC voltage (RMS voltage) controllers (AC to AC converters).
- Cyclo converters (AC to AC converters at low output frequency).
- DC choppers (DC to DC converters).
- Inverters (DC to AC converters).

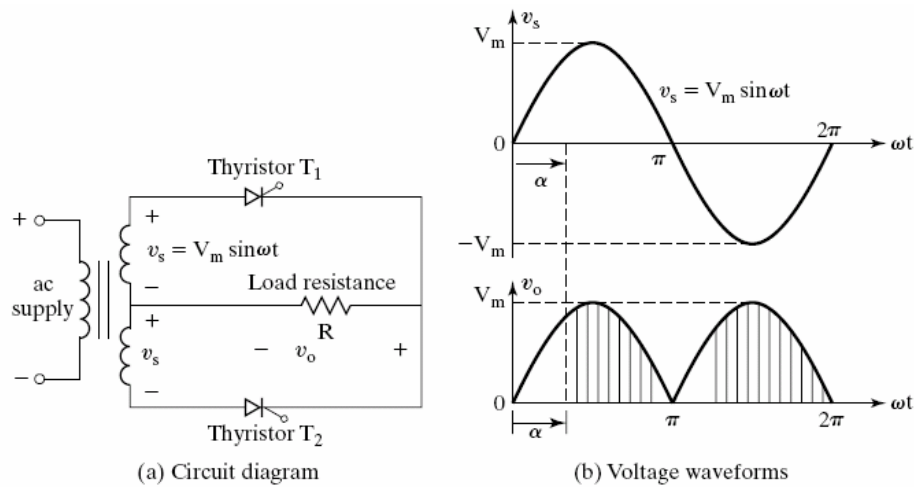
### LINE COMMUTATED CONVERTERS (AC TO DC CONVERTERS)



These are AC to DC converters. The line commutated converters are AC to DC power converters. These are also referred to as controlled rectifiers. The line commutated converters (controlled rectifiers) are used to convert a fixed voltage, fixed frequency AC power supply to obtain a variable DC output voltage. They use natural or AC line commutation of the Thyristors.



**Fig: A Single Phase Full Wave Uncontrolled Rectifier Circuit (Diode Full Wave Rectifier) using a Center Tapped Transformer**



**Fig: A Single Phase Full Wave Controlled Rectifier Circuit (using SCRs) using a Center Tapped Transformer**

Different types of line commutated AC to DC converters circuits are

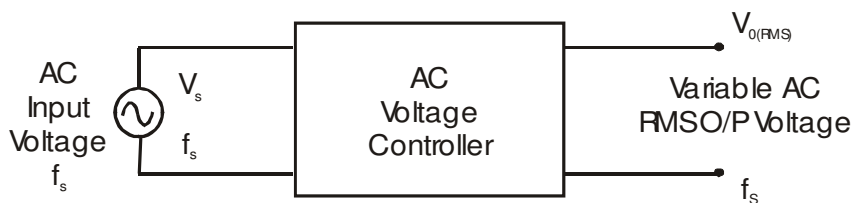
- Diode rectifiers – Uncontrolled Rectifiers
- Controlled rectifiers using SCR's.
  - Single phase controlled rectifier.
  - Three phase controlled rectifiers.

**Applications Of Line Commutated Converters**

AC to DC power converters are widely used in

- Speed control of DC motor in DC drives.
- UPS.
- HVDC transmission.
- Battery Chargers.

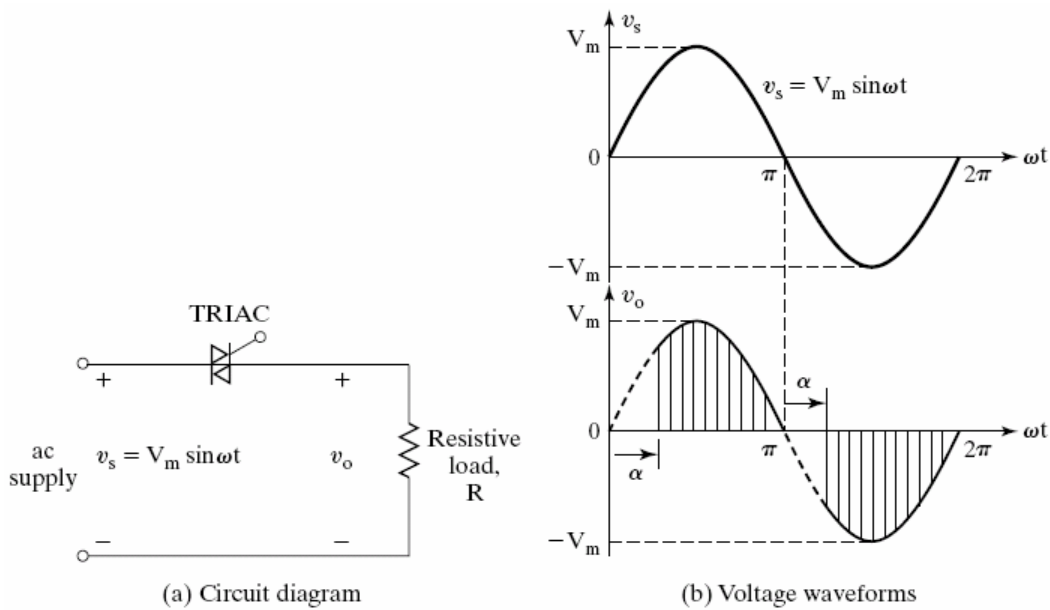
**AC VOLTAGE REGULATORS OR RMS VOLTAGE CONTROLLERS (AC TO AC CONVERTERS)**



The AC voltage controllers convert the constant frequency, fixed voltage AC supply into variable AC voltage at the same frequency using line commutation.

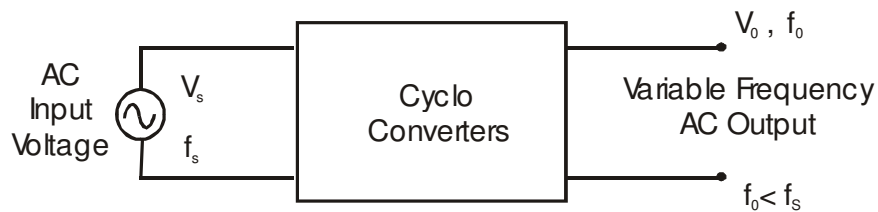
AC regulators (RMS voltage controllers) are mainly used for

- Speed control of AC motor.
- Speed control of fans (domestic and industrial fans).
- AC pumps.



**Fig: A Single Phase AC voltage Controller Circuit (AC-AC Converter using a TRIAC)**

### CYCLO CONVERTERS (AC TO AC CONVERTERS WITH LOW OUTPUT FREQUENCY)

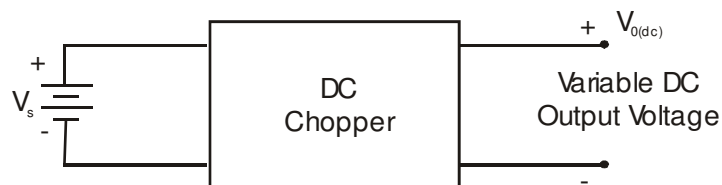


The cyclo converters convert power from a fixed voltage fixed frequency AC supply to a variable frequency and variable AC voltage at the output.

The cyclo converters generally produce output AC voltage at a lower output frequency. That is output frequency of the AC output is less than input AC supply frequency.

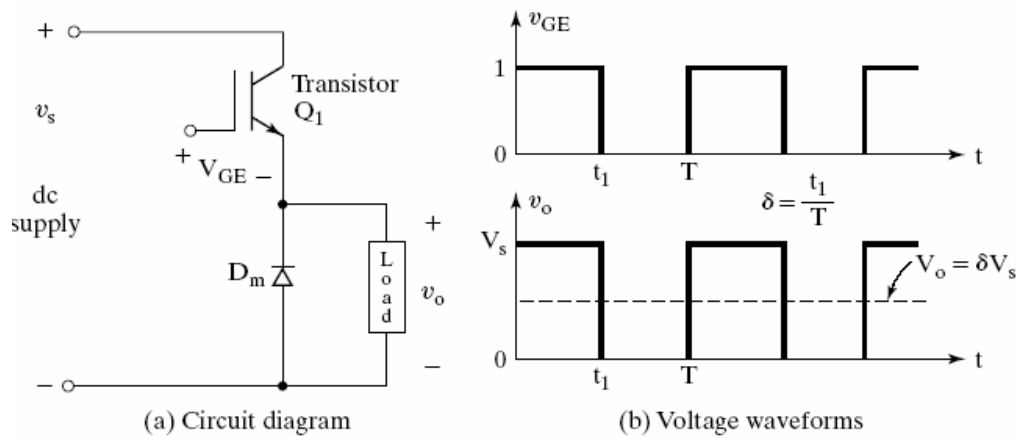
*Applications of cyclo converters* are traction vehicles and gearless rotary kilns.

### CHOPPERS (DC TO DC CONVERTERS)



The choppers are power circuits which obtain power from a fixed voltage DC supply and convert it into a variable DC voltage. They are also called as DC choppers or DC to DC converters. Choppers employ forced commutation to turn off the Thyristors. DC choppers are further classified into several types depending on the direction of power flow and the type of commutation. DC choppers are widely used in

- Speed control of DC motors from a DC supply.
- DC drives for sub-urban traction.
- Switching power supplies.



**Fig: A DC Chopper Circuit (DC-DC Converter) using IGBT**

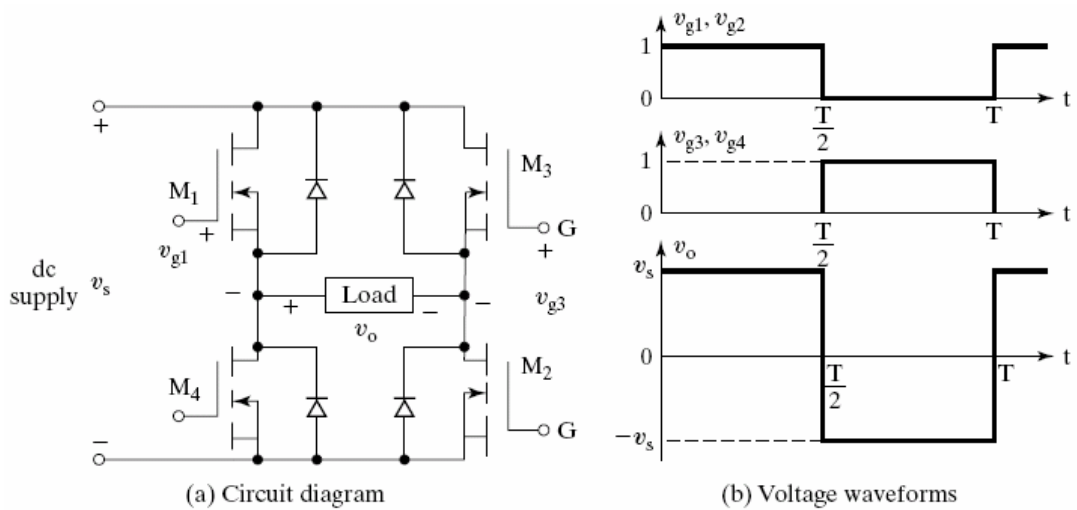
### INVERTERS (DC TO AC CONVERTERS)



The inverters are used for converting DC power from a fixed voltage DC supply into an AC output voltage of variable frequency and fixed or variable output AC voltage. The inverters also employ force commutation method to turn off the Thyristors.

**Application of inverters** are in

- Industrial AC drives using induction and synchronous motors.
- Uninterrupted power supplies (UPS system) used for computers, computer labs.



**Fig: Single Phase DC-AC Converter (Inverter) using MOSFETS**

## DESIGN OF POWER ELECTRONICS CIRCUITS

The design and study of power electronic circuits involve

- Design and study of power circuits using Thyristors, Diodes, BJT's or MOSFETS.
- Design and study of control circuits.
- Design and study of logic and gating circuits and associated digital circuits.
- Design and study of protection devices and circuits for the protection of thyristor power devices in power electronic circuits.

The power electronic circuits can be classified into six types

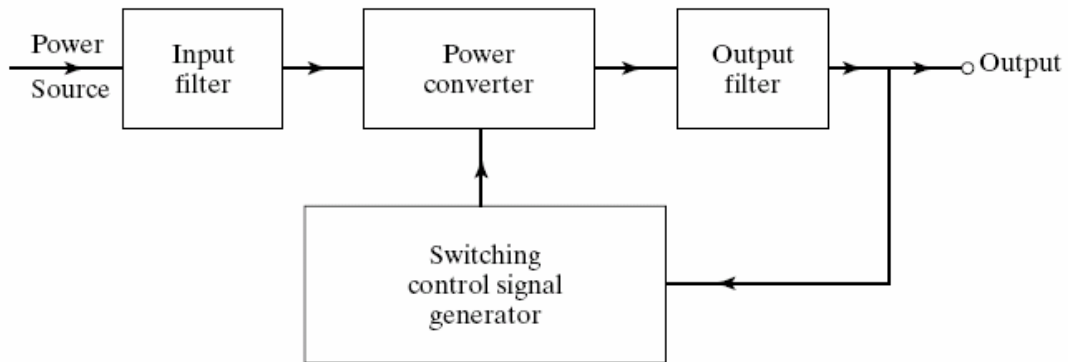
- Diode rectifiers (uncontrolled rectifiers)
- AC to DC converters (Controlled rectifiers)
- AC to AC converters (AC voltage controllers)
- DC to DC converters (DC choppers)
- DC to AC converters (Inverters)
- Static Switches (Thyristorized contactors)

## PERIPHERAL EFFECTS

The power converter operations are based mainly on the switching of power semiconductor devices and as a result the power converters introduce current and voltage harmonics (unwanted AC signal components) into the supply system and on the output of the converters.

These induced harmonics can cause problems of distortion of the output voltage, harmonic generation into the supply system, and interference with the communication and signaling circuits. It is normally necessary to introduce filters on the input side and output side of a power converter system so as to reduce the harmonic level to an acceptable magnitude. The figure below shows the block diagram of a generalized power converter with filters added. The application of power electronics to supply the sensitive electronic

loads poses a challenge on the power quality issues and raises the problems and concerns to be resolved by the researchers. The input and output quantities of power converters could be either AC or DC. Factors such as total harmonic distortion (THD), displacement factor or harmonic factor (HF), and input power factor (IPF), are measures of the quality of the waveforms. To determine these factors it is required to find the harmonic content of the waveforms. To evaluate the performance of a converter, the input and output voltages/currents of a converter are expressed in Fourier series. The quality of a power converter is judged by the quality of its voltage and current waveforms.



**Fig: A General Power Converter System**

The control strategy for the power converters plays an important part on the harmonic generation and the output waveform distortion and can be aimed to minimize or reduce these problems. The power converters can cause radio frequency interference due to electromagnetic radiation and the gating circuits may generate erroneous signals. This interference can be avoided by proper grounding and shielding.