

Adobe Photoshop 7.0 CE



"The path to creativity"

**Gilmar Sacayanan**  
&  
**Rajinder Bimrah**

---



# Adobe Photoshop 7.0 CE



"The path to creativity"

Photoshop 7 “The path to creativity”

Text copyright Gil and Zohar Design

ISBN:

Design & Production: Gil and Zohar Design  
Editors: Gilmar Sacayanan Rajinder Bimrah  
Screenshots done on PC  
Tutorial tester: Jung Hee Ban

Printed in Canada.

# Acknowledgments

---

We would like to thank our teacher Jan Richman, our families, friends and many web artists all over the net for supporting us in making this book come alive.

# About the authors

---

Gil and Raj are currently second year students in Publication Design and Hypermedia at John Abbott College. They both have experience with Adobe Illustrator, Photoshop, and Macromedia, and Quark Express 5. They both work hard at what they do. Gil can be reached at: [gilmar@aei.ca](mailto:gilmar@aei.ca), and Raj at: [rbimrah@johnabbottcollege.net](mailto:rbimrah@johnabbottcollege.net).

# Contents

---

Acknowledgments .....	iv
About the authors .....	v
Contents .....	vi
Introduction .....	vii
Section 1: Grids .....	1
Making the pattern .....	2
Applying the effect .....	5
Section 2: 45 Degree Lines .....	9
Making the pattern .....	10
Applying the effect .....	13
Section 3: Scan lines .....	17
Making the pattern .....	18
Applying the effect .....	21
Reference .....	24
Changing the color of a grid .....	24
Making a random pattern .....	24
Scanlines effect .....	24
Glossary .....	25
Index .....	26

# System Requirements

## Windows Requirements

Photoshop requires at least a Pentium III-class processor, 128MB of available RAM, a video card capable of 8-bit color (256 total colors), and a monitor capable of displaying a resolution of at least 800x600 pixels. Realistically, consider at least 192MB of RAM (128MB for Photoshop, 64MB for the operating system) and a video card with at least 16MB of on-board video memory (VRAM). In addition, you'll likely want a monitor displaying a minimum of thousands of colors with resolution set to at least 1024x768 pixels—with the minimum resolution, you'd not be able to take advantage of Photoshop's Palette Well.

In addition to the hardware requirements, the operating system must be one of the following:

- Windows XP
- Windows 2000
- Windows NT 4.0 (service pack 6a)
- Windows ME
- Windows 98 SE
- Windows 98

**Note** that Photoshop 7 will not run on Windows 95.

## Macintosh Requirements

Adobe lists the minimum Macintosh requirements as any PowerPC G3 or G4 processor, 128MB of RAM, an 8-bit video card, and a monitor set to 800x600 pixel resolution. Photoshop also requires Mac OS 9.1 or later, or Mac OS X version 10.1 or later.

In reality, a suitable system starts with at least a G3 processor, preferably running at 350MHz or faster (Blue and White G3). With 256MB of physical RAM, both Photoshop and the operating system can fulfill their needs (although Virtual Memory would still be a good idea). The video board should have a minimum of 16MB of on-board VRAM and be capable of supporting a monitor displaying 800x600 pixels at thousands of colors. Remember that at 800x600, the Palette Well doesn't appear in the Options Bar.

# Introduction

---

Already, there have been many books published on Photoshop 7. Within this book, we explore many different techniques of creating artistic design, which will hopefully set this textbook apart from the rest. We tried to make the tutorials as easy as possible and yet you get the benefit of getting advanced knowledge and tips and tricks to design web page and page layouts. This book is aimed for anyone who desires inspiration in which will help everyone be more creative.



# Section 1

# Section 1: Grids

The grid pattern is a very easy effect to create in Photoshop and it can make your images look very professional in no time.

## Making the pattern

1. Go to File->New and create a new document with 10x10 pixel box, transparent, 72 dpi, mode-RGB color and the title: Grids and Click Ok.

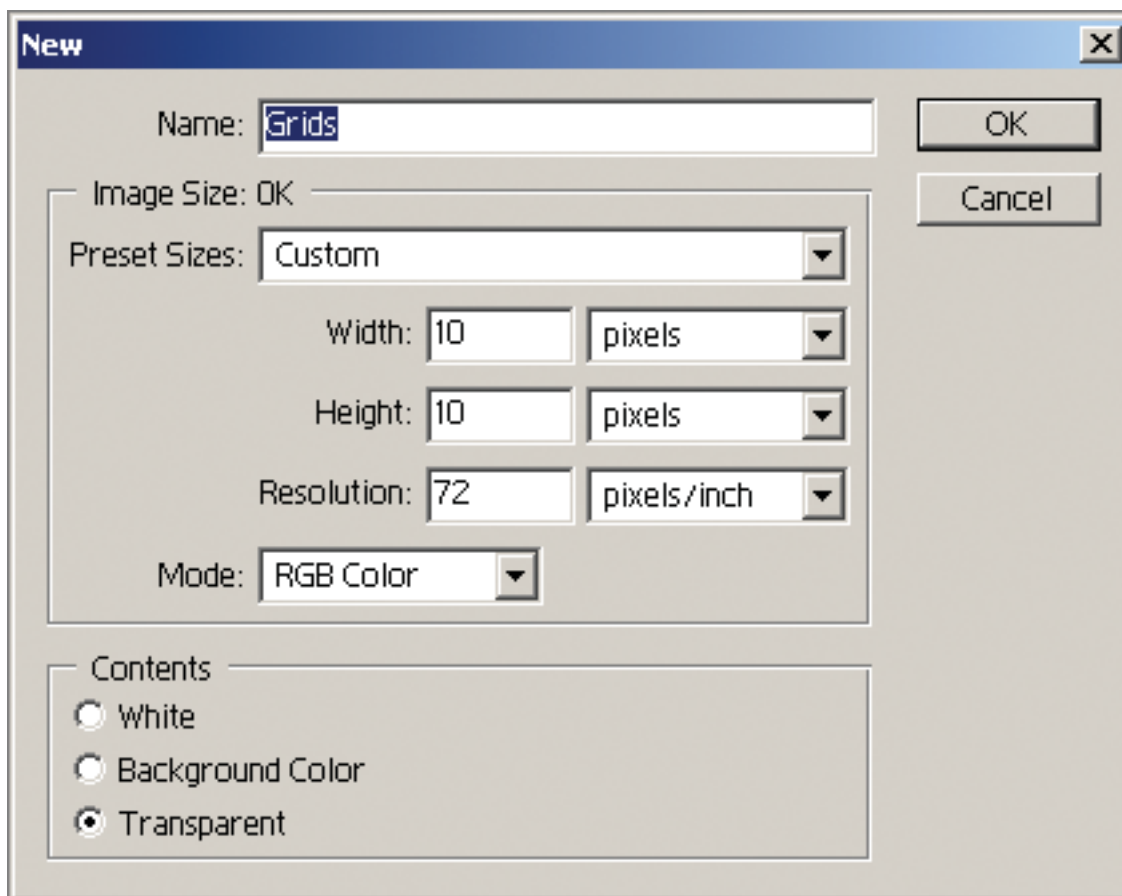

New window in Photoshop 7

2. Using the navigator window zoom to 1600% using the slider at the bottom.

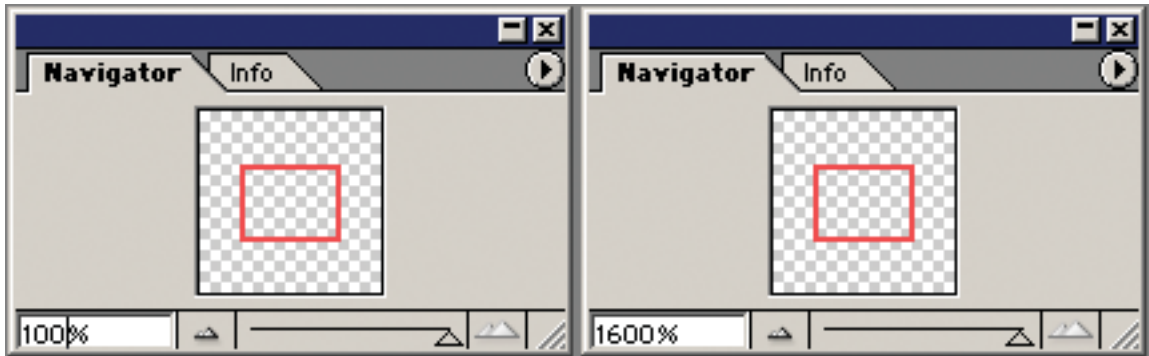

Navigator palette

**Note:** If you can't find the navigator window, go to Window-Navigator.

3. With the file now zoomed in, it should look something like this:

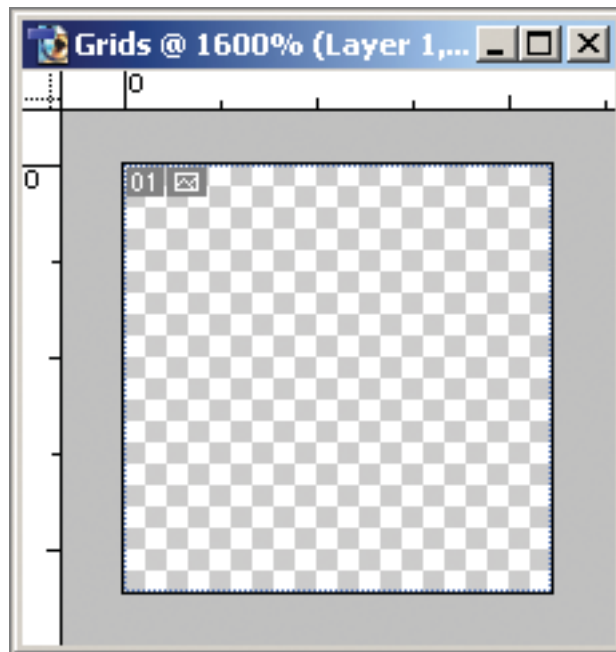

4. Now select the Rectangular Marquee Tool and create this selection:

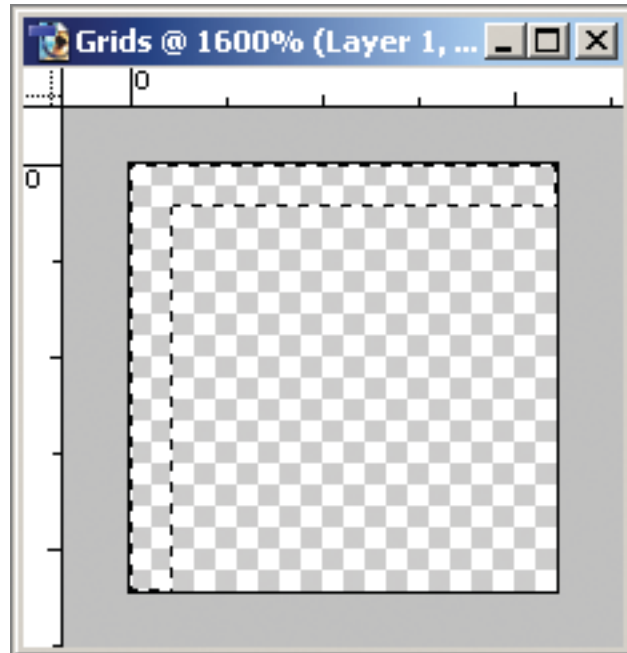

*\*Note: Use the shift key to help you make this horizontal and vertical selection.*

5. Use the Paint Bucket Tool and Fill the selection with black or any colour you want.

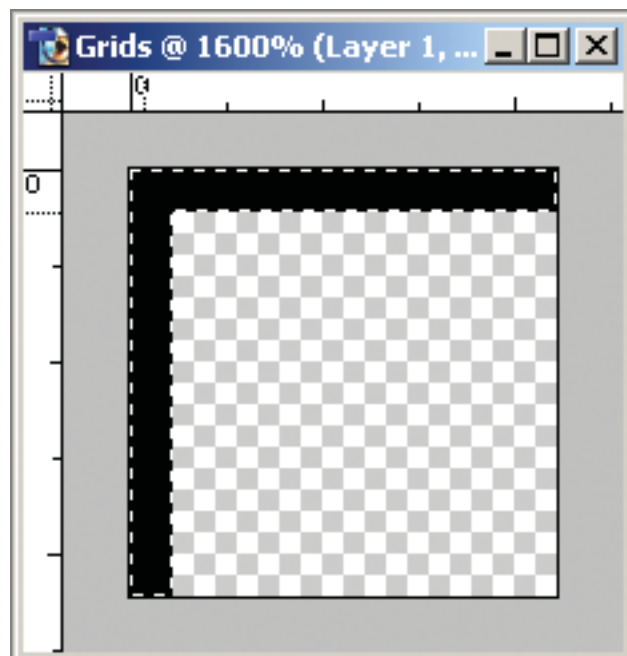

**Note:** Make sure that the Fill is "Foreground"



6. Go to Select - Deselect (CTRL+D)

7. Now go to Edit->Define Pattern. Name your new pattern "Grids"

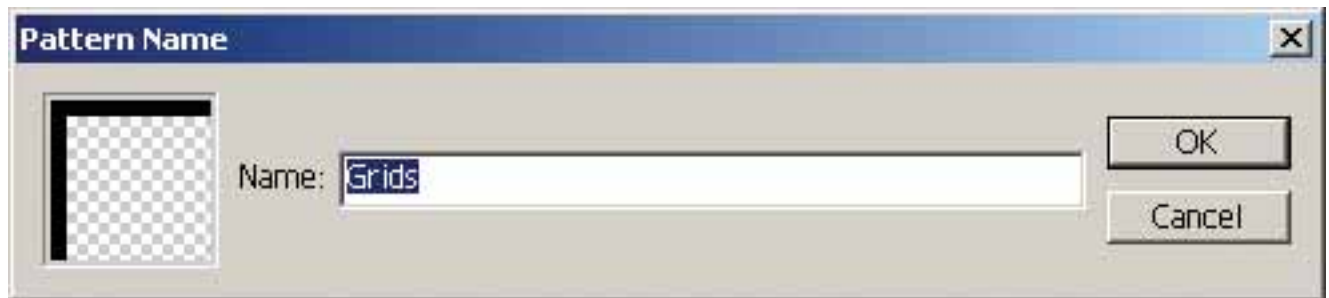

8. Press ok and close your document without saving.

## Applying the effect

1. Using the cd supplied to you, open the pictures beforegrids.jpg and aftergrids.jpg to see the difference and then close both.

2. Copy beforegrids.jpg to your work drive.

3. Open beforegrids.jpg and create a new layer

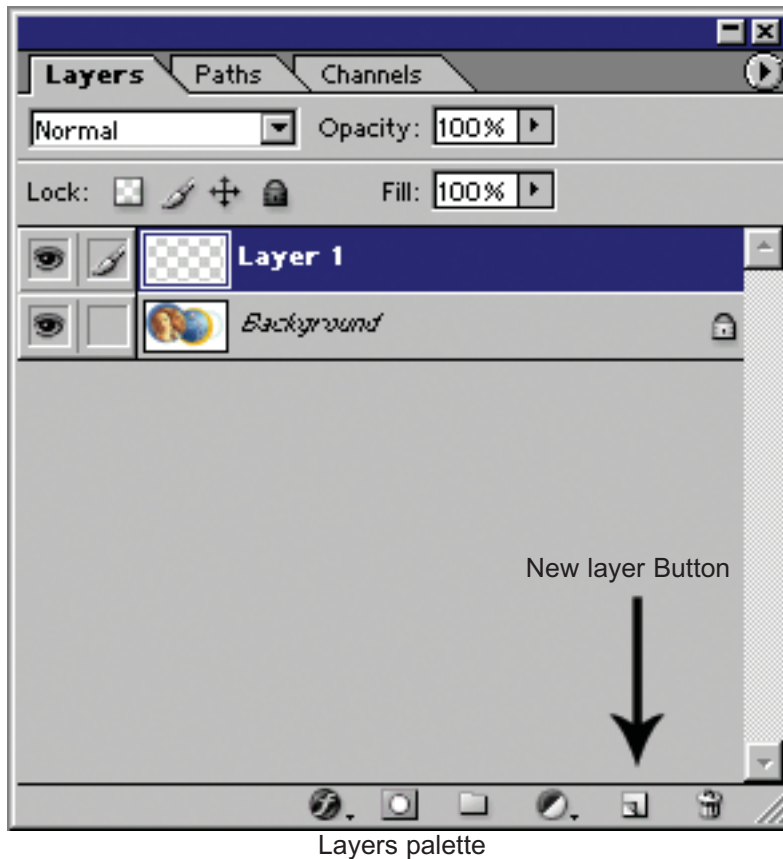

4. Using the Paint Bucket Tool, change the Fill option to pattern.



5. Select the Grids pattern that you have just created

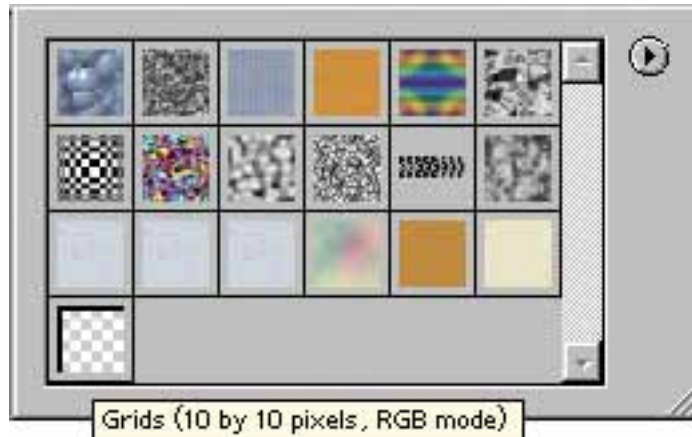

6. Using the Paint Bucket Tool, fill this pattern to Layer 1.

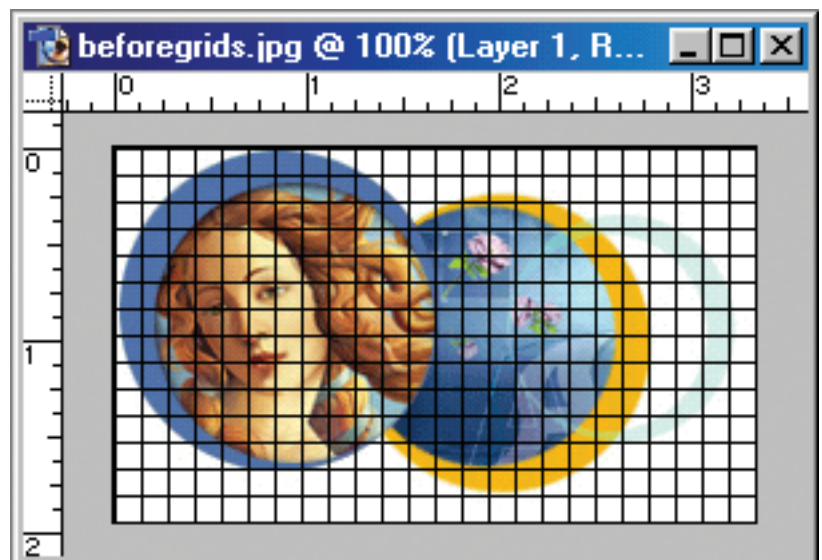

7. Pull down the opacity of Layer 1 to 10 %.

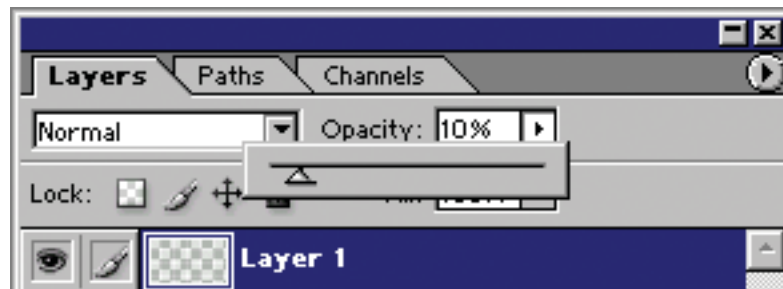

8. Image should turn out like this

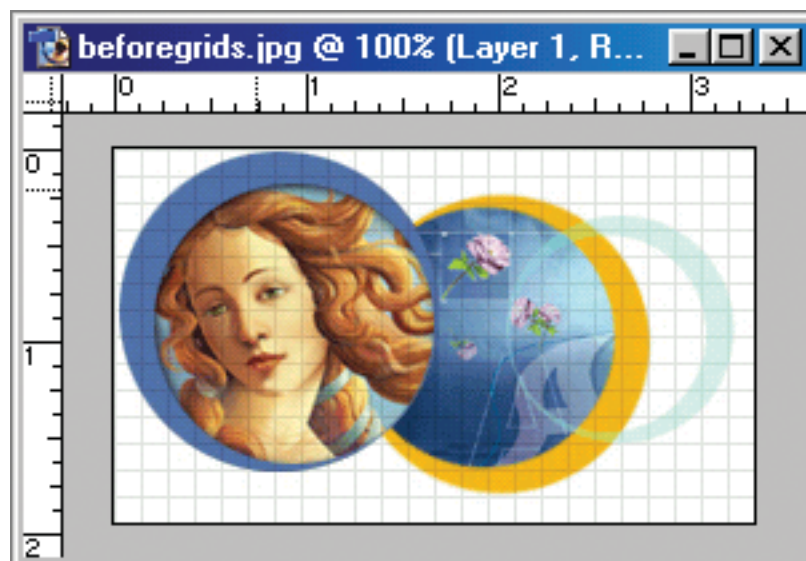

**Congratulations! You have just made yourself a grid effect on an image. This effect is a neat way to alter images and use them on Grid style websites.**



# Section 2

# Section 2: 45 Degree Lines

In this section, you will learn how to create 45 degree angle scan lines. This pattern is mostly used as tiling background images and image-overlays.

## Making the pattern

1. Go to File->New and create a new document with 3x3 pixel box, transparent, 72 dpi, mode-RGB color and the title: 45 Degree Lines and Click Ok.

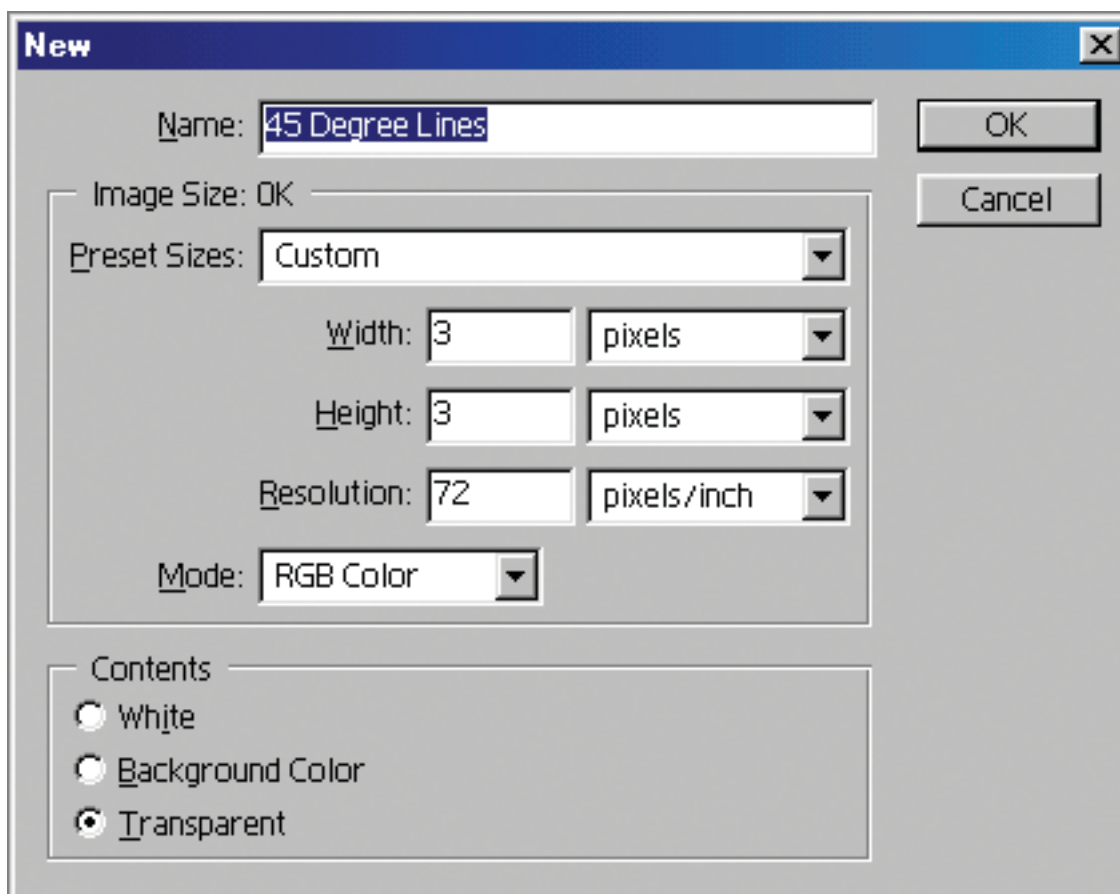

New window in Photoshop 7

2. Using the navigator window zoom to 1600% using the slider at the bottom.

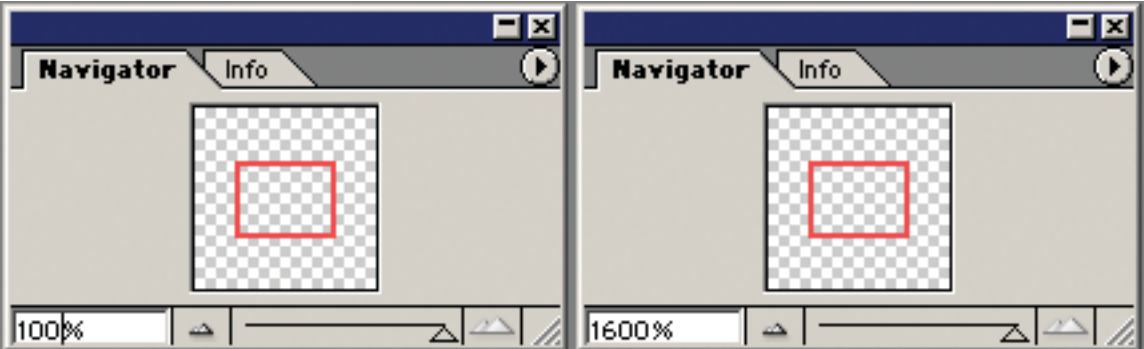

Navigator palette

**Note:** If you can't find the navigator window, go to Window-Navigator.

3. With the file now zoomed in, it should look something like this:

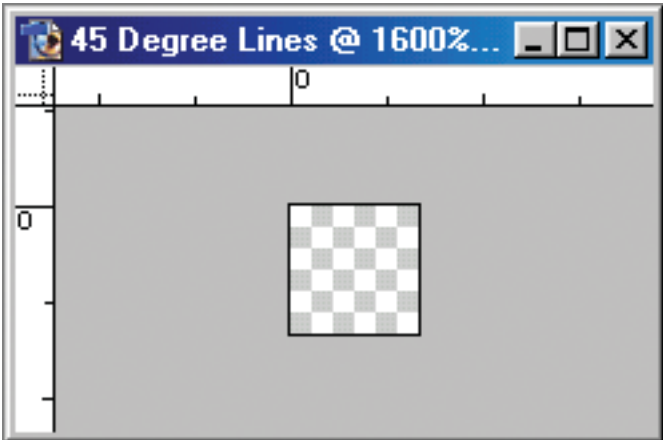

4. Now select the Rectangular Marquee Tool and create this selection:

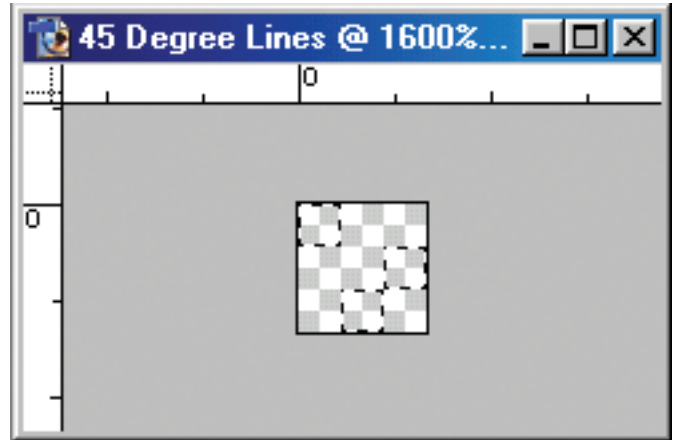

**Note:** Use the shift key to help you create this pattern.

5. Use the Paint Bucket Tool and Fill the selection with black or any colour you want.

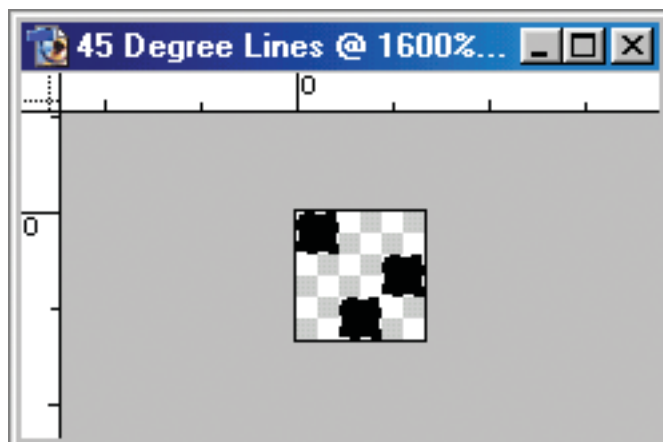

**Note:** Make sure that the Fill is "Foreground"



6. Go to Select - Deselect (CTRL+D)

7. Now go to Edit->Define Pattern. Name your new pattern "45 Degree Lines"

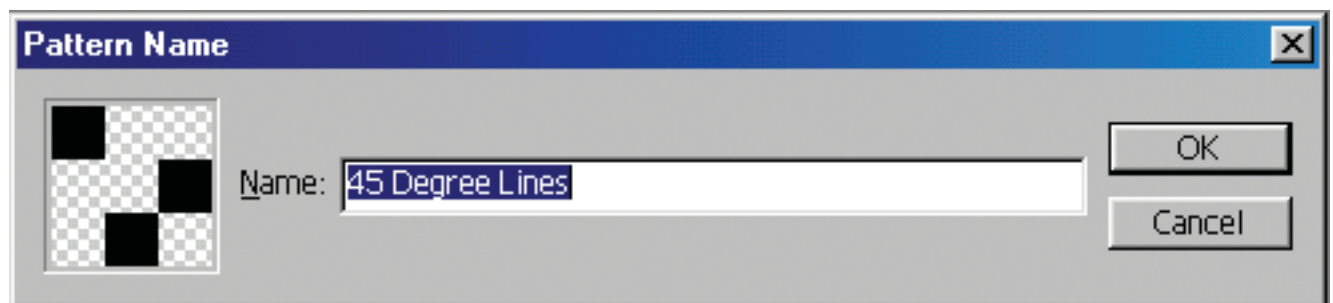

8. Press ok and close your document without saving.

## Applying the effect

1. Using the cd supplied to you, open the pictures before45.jpg and after45.jpg to see the difference and then close both.

2. Copy before45.jpg to your work drive.

3. Open before45.jpg and create a new layer.

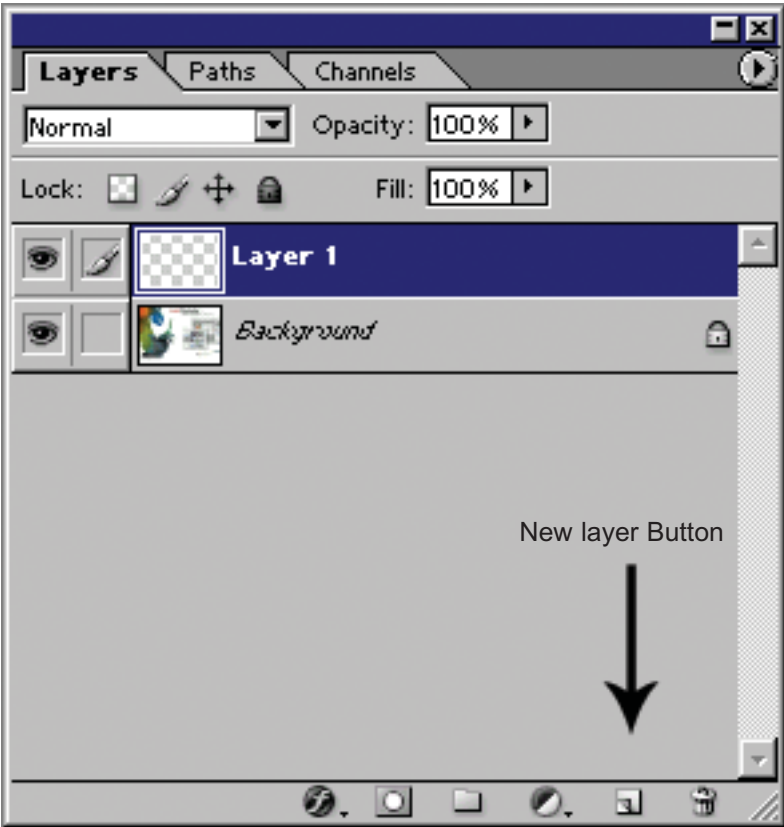

Layers palette

4. Using the Paint Bucket Tool, change the Fill option to pattern.



5. Select the 45 Degree Lines pattern that you have just created

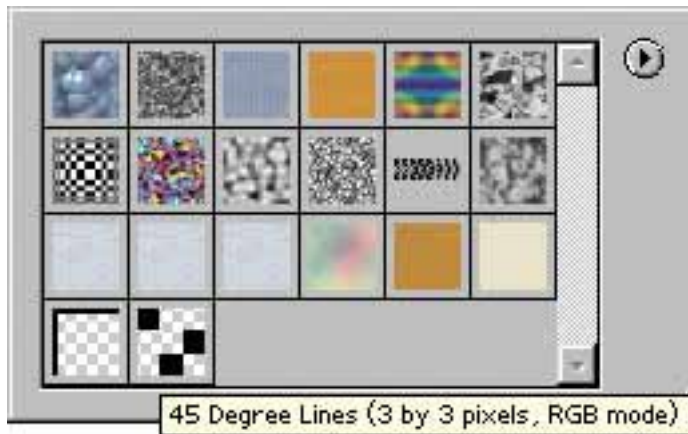

6. Using the Paint Bucket Tool, fill this pattern to Layer 1.

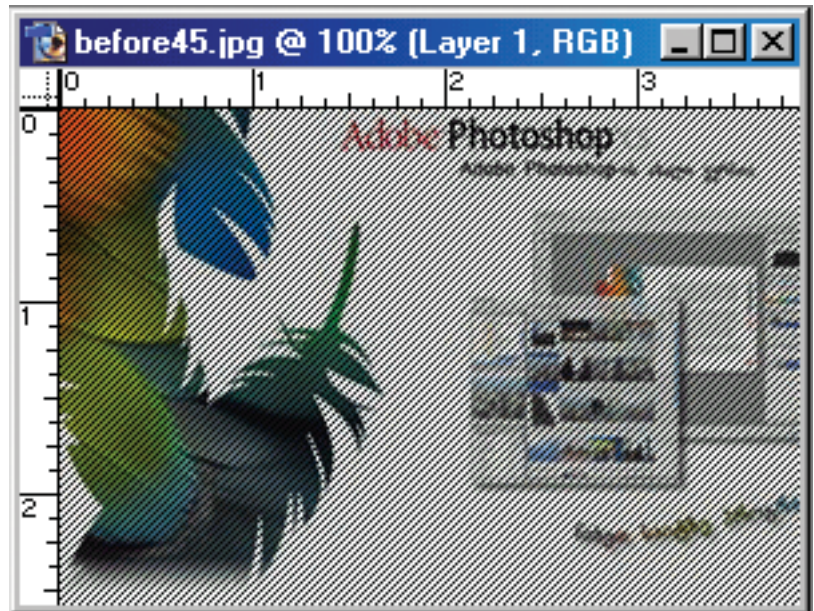

7. Set the blending mode to Overlay and change the opacity level to 50 %.

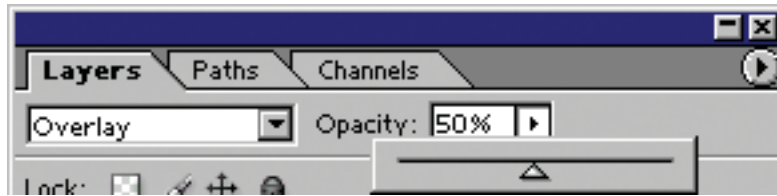

8. Image should turn out like this.

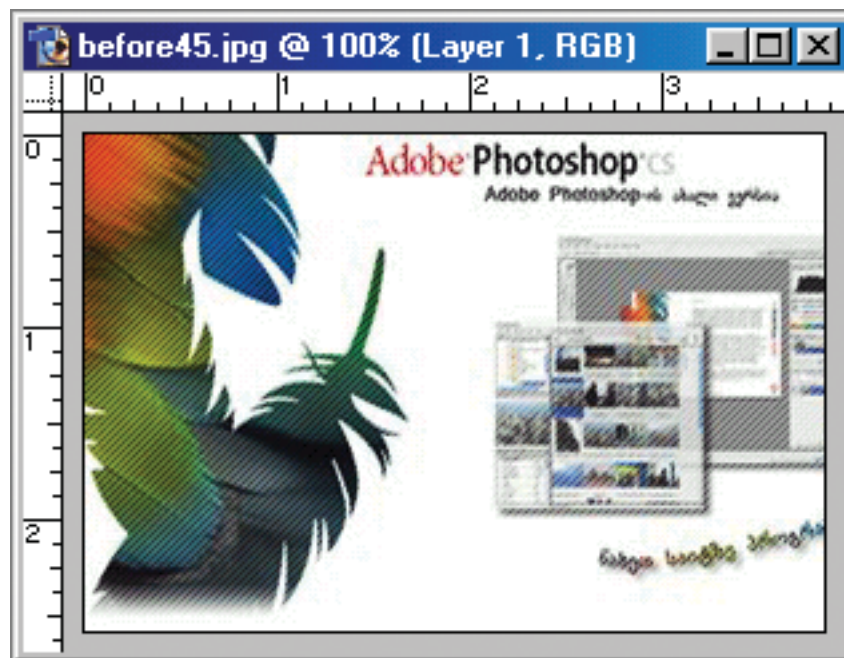

**Congratulations! You have just made yourself a 45 degree angle lines effect on an image.**



# Section 3

# Section 3: Scan lines

In this section, you will learn how to create tv scan lines. This is a very popular effect on the Web and it gives your images a high-tech sort of feel.

## Making the pattern

1. Go to File->New and create a new document with 1x 4 pixel box, white, 72 dpi, mode-RGB color and the title: Scan lines and Click Ok.

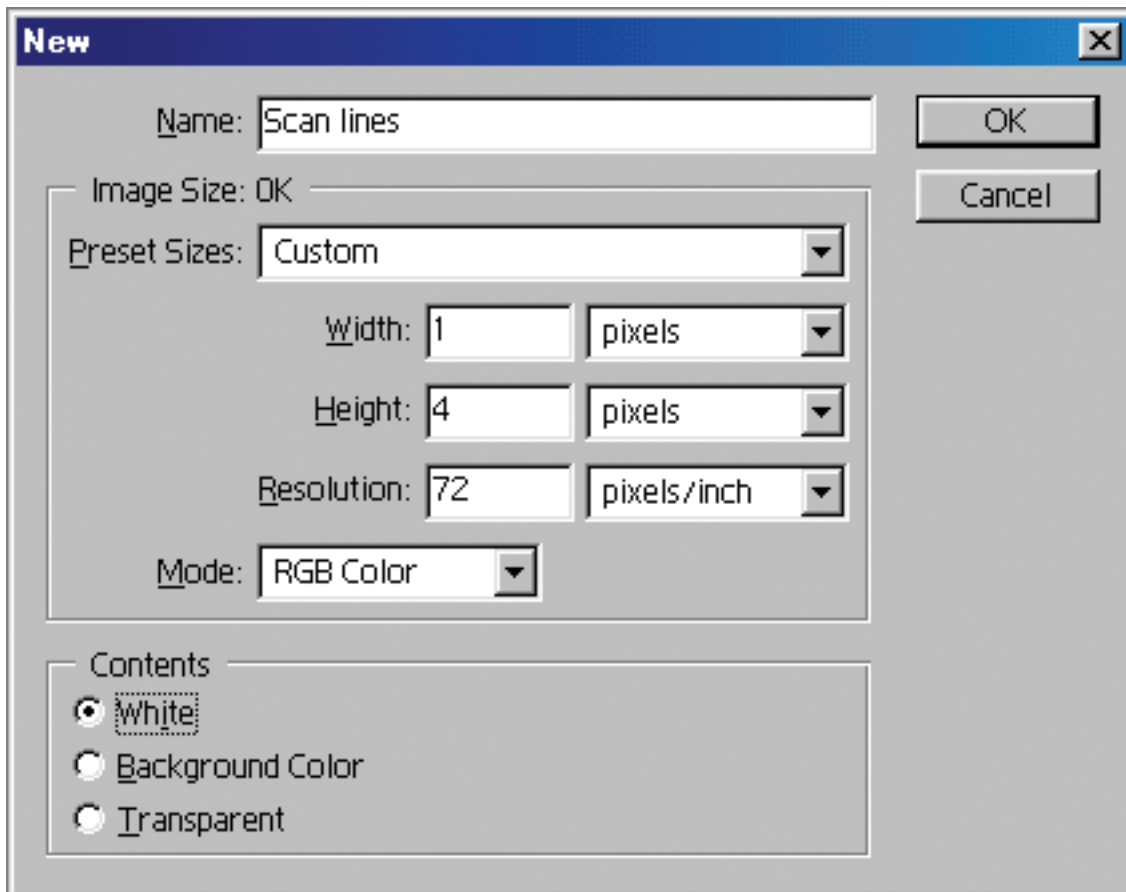

New window in Photoshop 7

2. Using the navigator window zoom to 1600% using the slider at the bottom.

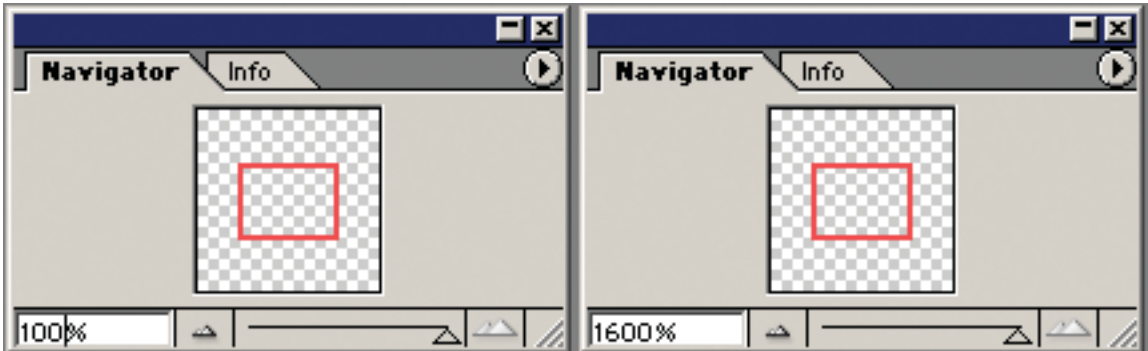

Navigator palette

**Note:** If you can't find the navigator window, go to Window-Navigator.

3. With the file now zoomed in, it should look something like this:

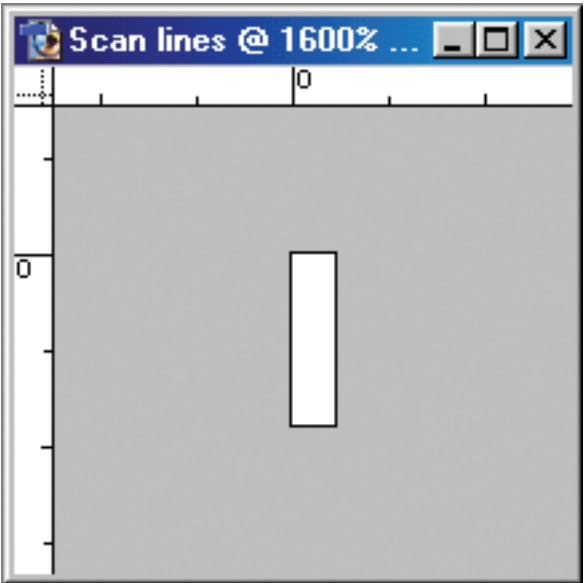

4. Now select the Rectangular Marquee Tool and create this selection:

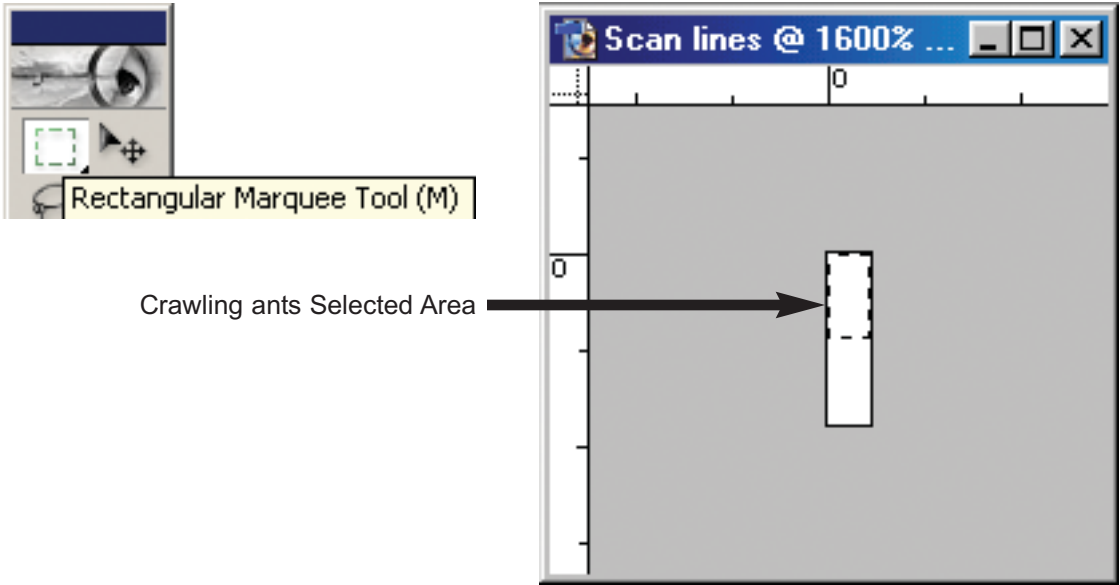

5. Use the Paint Bucket Tool and Fill the selection with black or any colour you want.

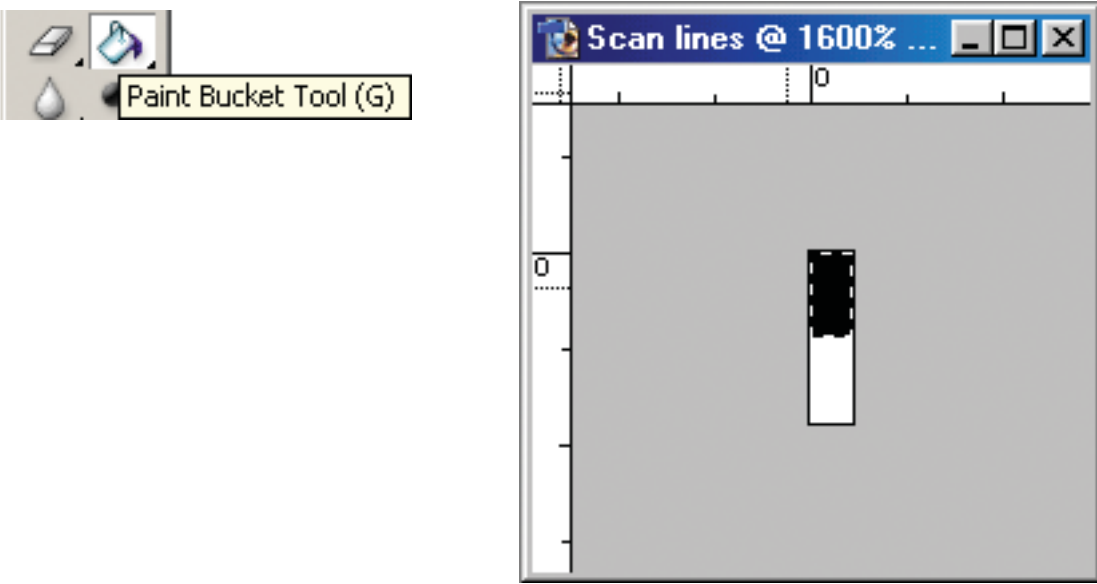

**Note:** Make sure that the Fill is “Foreground”



6. Go to Select - Deselect (CTRL+D)

7. Now go to Edit->Define Pattern. Name your new pattern “ Scan lines”

## Applying the effect

1. Using the cd supplied to you, open the pictures beforescanlines.jpg and afterscanlines.jpg to see the difference and then close both.

2. Copy beforescanlines.jpg to your work drive.

3. Open before45.jpg and create a new layer.

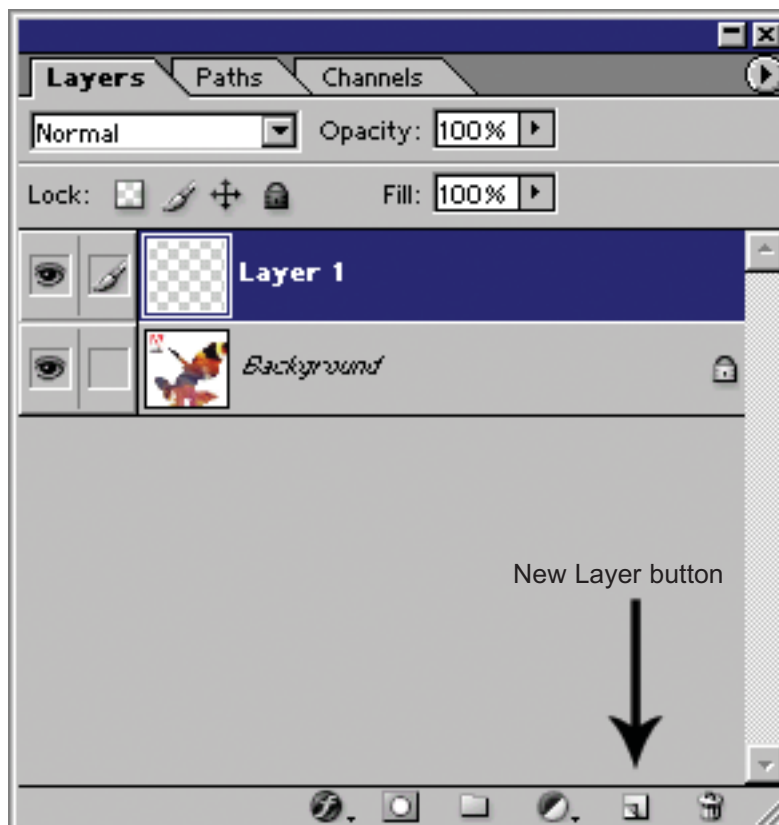

Layers palette

- Using the Paint Bucket Tool, change the Fill option to pattern.



- Select the Scan lines pattern that you have just created.

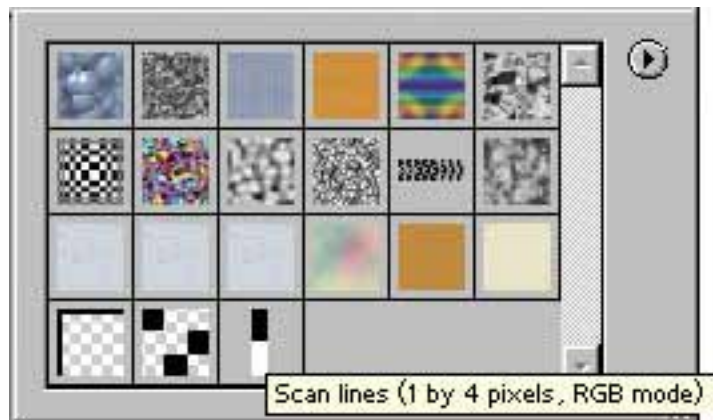

- Using the Paint Bucket Tool, fill this pattern to Layer 1.

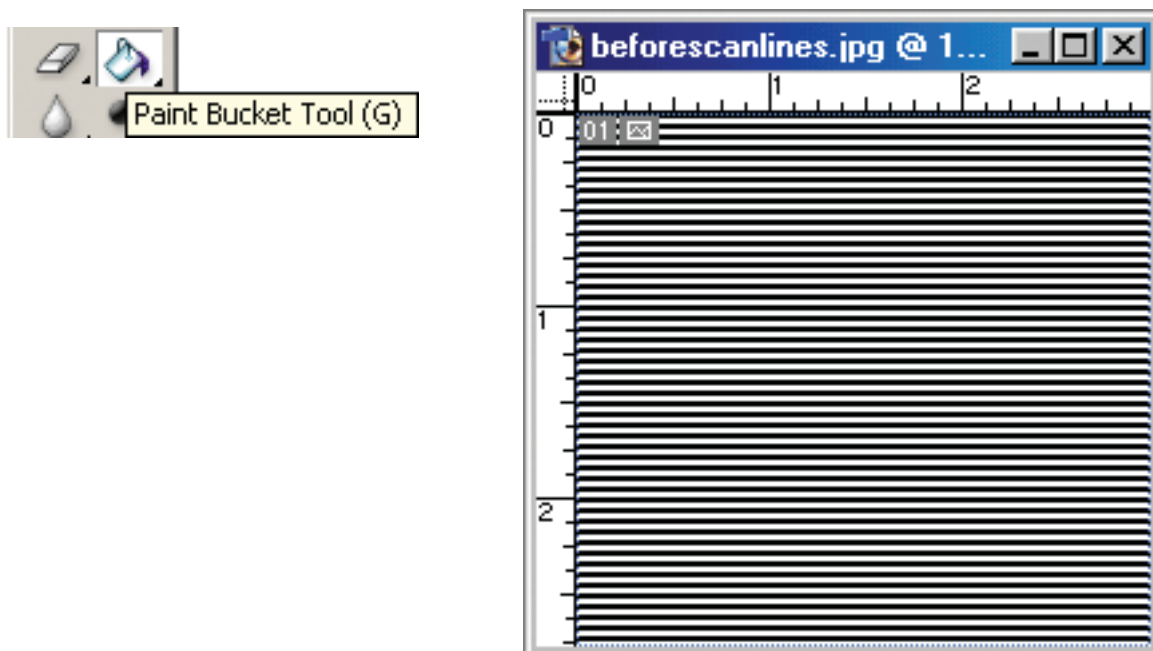

7. Pull down the opacity of Layer 1 to 10 %.

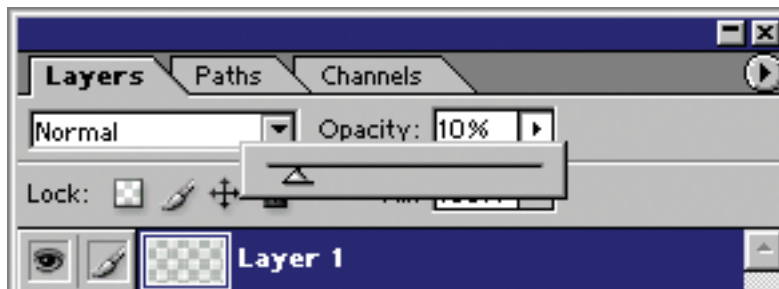

8. Image should turn out like this

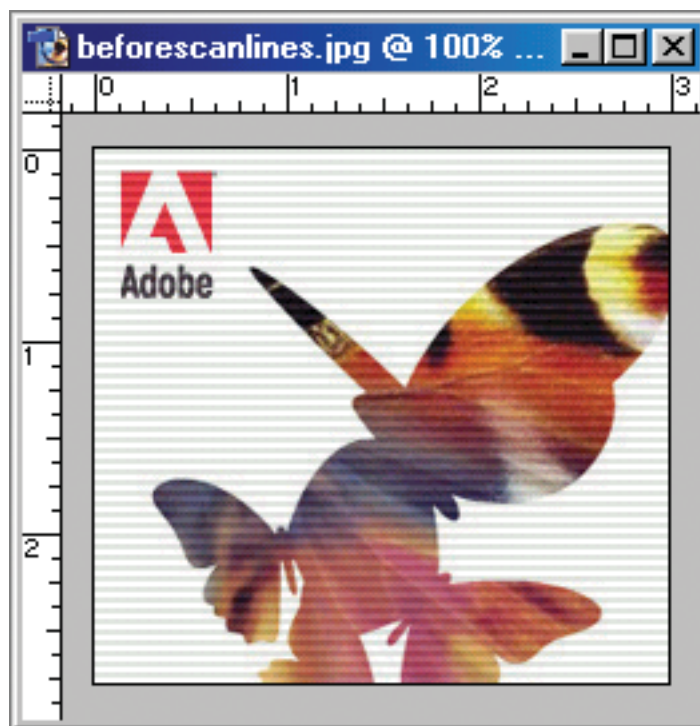

Congratulations! You have just made yourself a tv scan lines effect on an image.

# Reference

---

Welcome to the reference section. This section requires that you have done the lesson. Also in this section we give different ideas of creating different effects with these patterns.

## **Changing the color of a grid**

1. Create a new file and make the L shape selection.
2. Fill it with any color of your choice except black and white, or a very light color.
3. Apply the pattern to any image but adjust the opacity to make it distinct.

## **Making a random pattern**

1. Create a new file.
2. Make random squares with different colors.
3. Apply the pattern to the picture adjusting the opacity.

## **Scanlines effect**

1. Create a new file.
2. Make the scanline pattern
3. Apply it to a image, and adjust the blending mode to something other than normal.
4. For a different effect adjust the colors of the pattern and set the opacity lower on the final image.

# Glossary

---

*grid*: a network of uniformly spaced horizontal and perpendicular lines (as for locating points on a map).

*layer*: one thickness, course, or fold laid or lying over or under another

*pixel*: any of the small discrete elements that together constitute an image (as on a television screen)

*pattern*: something designed or used as a model for making things.

*RGB*: Red Green Blue, the color model used for the web and pc.

*DPI*: Dots Per Inch, is a measure of printing resolution, in particular the number of individual dots of ink a printer or toner can produce within a linear one-inch space. The standard DPI for the web is 72-100. Desktop (Home printing) is 200 DPI. And for the press its 300 DPI.

# Index

## **J**

John Abbott College.....v

## **R**

Reference.....24

*blending mode*.....24

*Changing the color of a grid*.....24

*Making a random pattern*.....24

*opacity*.....24

*Scanlines effect*.....24

Richman, Jan.....iv

## **S**

Section 1: Grids.....2

*grid effect*.....8

*grid pattern*.....2

*Grid style*.....8

*Making the pattern*.....2

*Paint Bucket Tool*.....4,7

*Rectangular Marquee Tool*.....4

Section 2: 45 Degree Lines.....10

*dpi*.....10

*Fill*.....13

*lines effect*.....16

*new layer*.....14

*Paint Bucket Tool*.....15

*Rectangular Marquee Tool*.....12

*Window-Navigator*.....11

Section 3: Scan lines.....18

*Deselect*.....21

*navigator window*.....19

*opacity*.....23

*Paint Bucket Tool*.....20,22

*pattern*.....22

*Rectangular Marquee Tool*.....20

*tv scan lines*.....18

System Requirements.....vii

