

## ADG918/ADG919

### FEATURES

Wideband Switch:  $-3$  dB @ 4 GHz  
 Absorptive/Reflective Switches  
 High Off Isolation (37 dB @ 1 GHz)  
 Low Insertion Loss (0.8 dB @ 1 GHz)  
 Single 1.65 V to 2.75 V Power Supply  
 CMOS/LVTTL Control Logic  
 8-Lead MSOP and Tiny 3 mm × 3 mm LFCSP Packages  
 Low Power Consumption ( $<1$   $\mu$ A)

### APPLICATIONS

Wireless Communications  
 General-Purpose RF Switching  
 Dual-Band Applications  
 High Speed Filter Selection  
 Digital Transceiver Front End Switch  
 IF Switching  
 Tuner Modules  
 Antenna Diversity Switching

### GENERAL DESCRIPTION

The ADG918/ADG919 are wideband switches using a CMOS process to provide high isolation and low insertion loss to 1 GHz. The ADG918 is an absorptive (matched) switch having 50  $\Omega$  terminated shunt legs, while the ADG919 is a reflective switch. These devices are designed such that the isolation is high over the dc to 1 GHz frequency range. They have on-board CMOS control logic, thus eliminating the need for external controlling circuitry. The control inputs are both CMOS and LVTTL

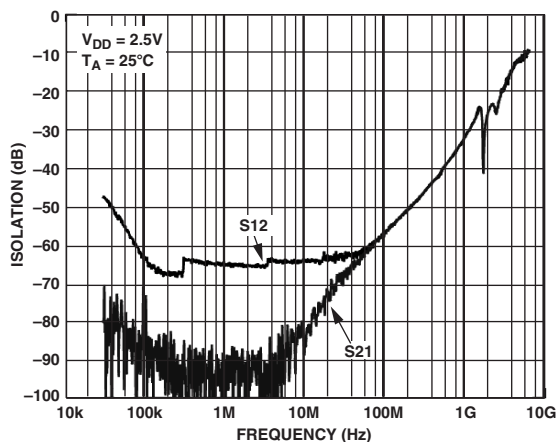

Figure 1. Off Isolation vs. Frequency

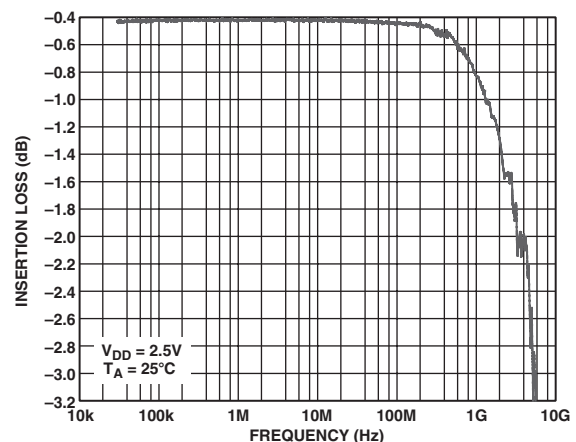
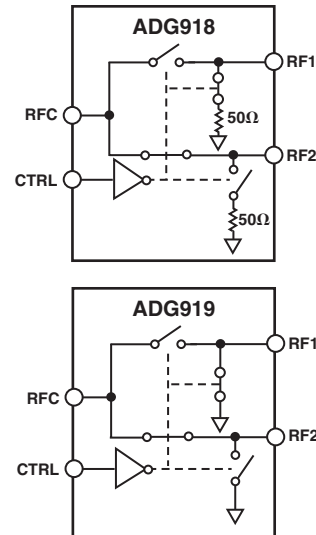

Figure 2. Insertion Loss vs. Frequency

### FUNCTIONAL BLOCK DIAGRAMS



compatible. The low power consumption of these CMOS devices makes them ideally suited to wireless applications and general-purpose high frequency switching.

### PRODUCT HIGHLIGHTS

1.  $-37$  dB Off Isolation @ 1 GHz
2. 0.8 dB Insertion Loss @ 1 GHz
3. Tiny 8-Lead MSOP/LFCSP Packages

REV. 0

Information furnished by Analog Devices is believed to be accurate and reliable. However, no responsibility is assumed by Analog Devices for its use, nor for any infringements of patents or other rights of third parties that may result from its use. No license is granted by implication or otherwise under any patent or patent rights of Analog Devices. Trademarks and registered trademarks are the property of their respective companies.

# ADG918/ADG919—SPECIFICATIONS<sup>1</sup> ( $V_{DD} = 1.65\text{ V}$ to $2.75\text{ V}$ , $GND = 0\text{ V}$ , input power = $0\text{ dBm}$ , all specifications $T_{MIN}$ to $T_{MAX}$ , unless otherwise noted.)

Parameter	Symbol	Conditions	B Version			Unit
			Min	Typ <sup>2</sup>	Max	
<b>AC ELECTRICAL CHARACTERISTICS</b>						
Operating Frequency <sup>3</sup>			DC		2	GHz
-3 dB Frequency <sup>4</sup>					4	GHz
Input Power <sup>4</sup>		0 V dc Bias			7	dBm
		0.5 V dc Bias			16	dBm
Insertion Loss	$S_{21}$ , $S_{12}$	DC to 100 MHz; $V_{DD} = 2.5\text{ V} \pm 10\%$		0.4	0.7	dB
		500 MHz; $V_{DD} = 2.5\text{ V} \pm 10\%$		0.5	0.8	dB
		1000 MHz; $V_{DD} = 2.5\text{ V} \pm 10\%$		0.8	1.25	dB
Isolation—RFC to RF1/RF2	$S_{21}$ , $S_{12}$	100 MHz	55	60		dB
		500 MHz	43	47		dB
		1000 MHz	34	37		dB
Isolation—RF1 to RF2 (Crosstalk)	$S_{21}$ , $S_{12}$	100 MHz	54	57		dB
		500 MHz	39	42		dB
		1000 MHz	31	33		dB
Return Loss (On Channel) <sup>4</sup>	$S_{11}$ , $S_{22}$	DC to 100 MHz	21	27		dB
		500 MHz	22	27		dB
		1000 MHz	22	26		dB
Return Loss (Off Channel) <sup>4</sup> ADG918	$S_{11}$ , $S_{22}$	DC to 100 MHz	18	23		dB
		500 MHz	17	21		dB
		1000 MHz	16	20		dB
On Switching Time <sup>4</sup>	$t_{ON}$	50% CTRL to 90% RF		6.6	10	ns
Off Switching Time <sup>4</sup>	$t_{OFF}$	50% CTRL to 10% RF		6.5	9.5	ns
Rise Time <sup>4</sup>	$t_{RISE}$	10% to 90% RF		6.1	9	ns
Fall Time <sup>4</sup>	$t_{FALL}$	90% to 10% RF		6.1	9	ns
1 dB Compression <sup>4</sup>	$P_{-1\text{ dB}}$	1000 MHz			17	dBm
Third Order Intermodulation Intercept	$IP_3$	900 MHz/901 MHz, 4 dBm	30	36		dBm
Video Feedthrough <sup>5</sup>				2.5		mV p-p
<b>DC ELECTRICAL CHARACTERISTICS</b>						
Input High Voltage	$V_{INH}$	$V_{DD} = 2.25\text{ V}$ to $2.75\text{ V}$	1.7			V
	$V_{INH}$	$V_{DD} = 1.65\text{ V}$ to $1.95\text{ V}$	0.65 $V_{CC}$			V
Input Low Voltage	$V_{INL}$	$V_{DD} = 2.25\text{ V}$ to $2.75\text{ V}$			0.7	V
	$V_{INL}$	$V_{DD} = 1.65\text{ V}$ to $1.95\text{ V}$			0.35 $V_{CC}$	V
Input Leakage Current	$I_I$	$0 \leq V_{IN} \leq 2.75\text{ V}$		$\pm 0.1$	$\pm 1$	$\mu\text{A}$
<b>CAPACITANCE<sup>4</sup></b>						
RF1/RF2, RF Port On Capacitance	$C_{RF\text{ ON}}$	$f = 1\text{ MHz}$		1.6		pF
CTRL Input Capacitance	$C_{CTRL}$	$f = 1\text{ MHz}$		2		pF
<b>POWER REQUIREMENTS</b>						
$V_{DD}$			1.65		2.75	V
Quiescent Power Supply Current	$I_{DD}$	Digital inputs = 0 V or $V_{DD}$		0.1	1	$\mu\text{A}$

## NOTES

<sup>1</sup>Temperature range B Version:  $-40^\circ\text{C}$  to  $+85^\circ\text{C}$ .

<sup>2</sup>Typical values are at  $V_{DD} = 2.5\text{ V}$  and  $25^\circ\text{C}$ , unless otherwise stated.

<sup>3</sup>Point at which insertion loss degrades by 1 dB.

<sup>4</sup>Guaranteed by design, not subject to production test.

<sup>5</sup>The dc transience at the output of any port of the switch when the control voltage is switched from high to low or low to high in a  $50\ \Omega$  test setup, measured with 1 ns rise time pulses and 500 MHz bandwidth.

Specifications subject to change without notice.

## ABSOLUTE MAXIMUM RATINGS<sup>1</sup>

(T<sub>A</sub> = 25°C, unless otherwise noted.)

V <sub>DD</sub> to GND	−0.5 V to +4 V
Inputs to GND	−0.5 V to V <sub>DD</sub> + 0.3 V <sup>2</sup>
Continuous Current	30 mA
Input Power	18 dBm
Operating Temperature Range	
Industrial (B Version)	−40°C to +85°C
Storage Temperature Range	−65°C to +150°C
Junction Temperature	150°C
MSOP Package	
θ <sub>JA</sub> Thermal Impedance	206°C/W

## LFCSP Package

θ <sub>JA</sub> Thermal Impedance (2-layer board)	84°C/W
θ <sub>JA</sub> Thermal Impedance (4-layer board)	48°C/W
Lead Temperature, Soldering (10 sec)	300°C
IR Reflow, Peak Temperature (<20 sec)	235°C
ESD	1 kV

### NOTES

<sup>1</sup> Stresses above those listed under Absolute Maximum Ratings may cause permanent damage to the device. This is a stress rating only and functional operation of the device at these or any other conditions above those listed in the operational sections of this specification is not implied. Exposure to absolute maximum rating conditions for extended periods may affect device reliability. Only one absolute maximum rating may be applied at any one time.

<sup>2</sup> RF1/RF2 Off Port Inputs to Ground ..... −0.5 V to V<sub>DD</sub> − 0.5 V

## ORDERING GUIDE

Model	Temperature Range	Package Description	Package Option	Branding
ADG918BRM	−40°C to +85°C	Mini Small Outline Package (MSOP)	RM-8	W4B
ADG918BRM-REEL7	−40°C to +85°C	Mini Small Outline Package (MSOP)	RM-8	W4B
ADG918BCP	−40°C to +85°C	Lead Frame Chip Scale Package (LFCSP)	CP-8*	W4B
ADG918BCP-REEL7	−40°C to +85°C	Lead Frame Chip Scale Package (LFCSP)	CP-8*	W4B
ADG919BRM	−40°C to +85°C	Mini Small Outline Package (MSOP)	RM-8	W5B
ADG919BRM-REEL7	−40°C to +85°C	Mini Small Outline Package (MSOP)	RM-8	W5B
ADG919BCP	−40°C to +85°C	Lead Frame Chip Scale Package (LFCSP)	CP-8*	W5B
ADG919BCP-REEL7	−40°C to +85°C	Lead Frame Chip Scale Package (LFCSP)	CP-8*	W5B

\*Contact factory for availability.

## CAUTION

ESD (electrostatic discharge) sensitive device. Electrostatic charges as high as 4000 V readily accumulate on the human body and test equipment and can discharge without detection. Although the ADG918/ADG919 features proprietary ESD protection circuitry, permanent damage may occur on devices subjected to high energy electrostatic discharges. Therefore, proper ESD precautions are recommended to avoid performance degradation or loss of functionality.



## PIN CONFIGURATION

8-Lead MSOP (RM-8)  
8-Lead 3 mm × 3 mm LFCSP (CP-8)

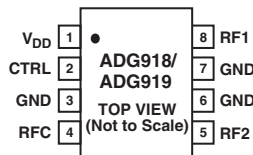

Table I. Truth Table

CTRL	Signal Path
0	RF2 to RFC
1	RF1 to RFC

## PIN FUNCTION DESCRIPTIONS

Pin No.	Mnemonic	Function
1	V <sub>DD</sub>	Power Supply Input. These parts can be operated from 1.65 V to 2.75 V, and V <sub>DD</sub> should be decoupled to GND.
2	CTRL	CMOS or TTL Logic Level; 0 → RF2 to RFC 1 → RF1 to RFC
3, 6, 7	GND	Ground Reference Point for All Circuitry on the Part
4	RFC	COMMON RF Port for Switch
5	RF2	RF2 Port
8	RF1	RF1 Port

# ADG918/ADG919

## TERMINOLOGY

Parameter	Description
$V_{DD}$	Most positive power supply potential
$I_{DD}$	Positive supply current
GND	Ground (0 V) reference
CTRL	Logic control input
$V_{INL}$	Maximum input voltage for Logic 0
$V_{INH}$	Minimum input voltage for Logic 1
$I_{INL}$ ( $I_{INH}$ )	Input current of the digital input
$C_{IN}$	Digital input capacitance
$t_{ON}$	Delay between applying the digital control input and the output switching on.
$t_{OFF}$	Delay between applying the digital control input and the output switching off.
$t_{RISE}$	Rise time. Time for the RF signal to rise from 10% to 90% of the ON level.
$t_{FALL}$	Fall time. Time for the RF signal to fall from 90% to 10% of the ON level.
Off Isolation	The attenuation between input and output ports of the switch when the switch control voltage is in the OFF condition.
Insertion Loss	The attenuation between input and output ports of the switch when the switch control voltage is in the ON condition.
$P_{-1\text{dB}}$	1 dB compression point. The RF input power level at which the switch insertion loss increases by 1 dB over its low level value. It is a measure of how much power the ON switch can handle before the insertion loss increases by 1 dB.
$IP_3$	Third order intermodulation intercept. This is a measure of the power in false tones that occur when closely spaced tones are passed through a switch, whereby the nonlinearity of the switch causes these false tones to be generated.
Return Loss	The amount of reflected power relative to the incident power at a port. Large return loss indicates good matching. By measuring Return Loss the VSWR can be calculated from conversion charts. VSWR (voltage standing wave ratio) indicates degree of matching present at a switch RF port.
Video Feedthrough	Spurious signals present at the RF ports of the switch when the control voltage is switched from high to low or low to high without an RF signal present.

# Typical Performance Characteristics—ADG918/ADG919

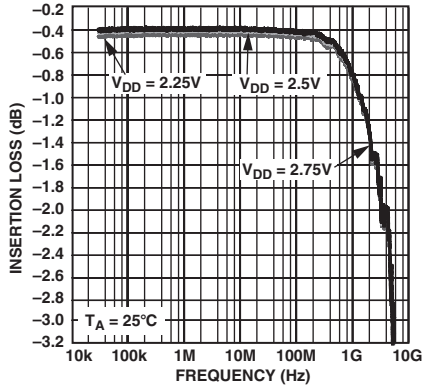

TPC 1. Insertion Loss vs. Frequency over Supplies (RF1/RF2, S12, and S21)

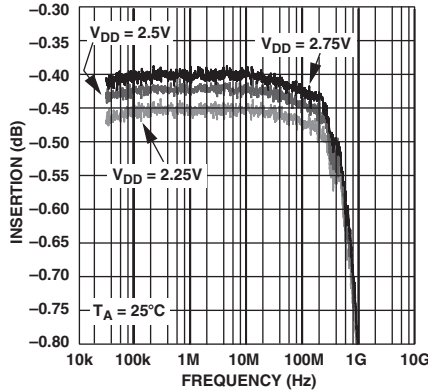

TPC 2. Insertion Loss vs. Frequency over Supplies (RF1/RF2, S12, and S21) (Zoomed TPC 1 Plot)

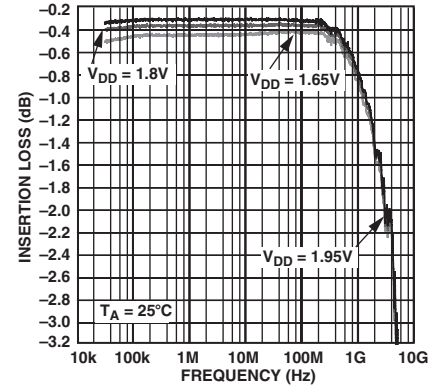

TPC 3. Insertion Loss vs. Frequency over Supplies (RF1/RF2, S12, and S21)

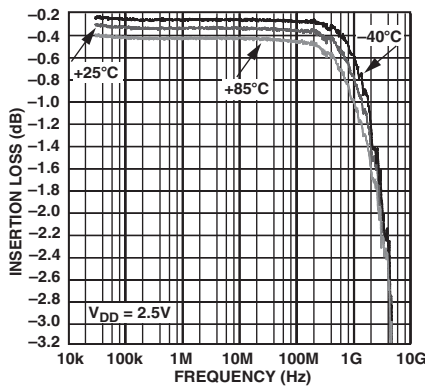

TPC 4. Insertion Loss vs. Frequency over Temperature (RF1/RF2, S12, and S21)

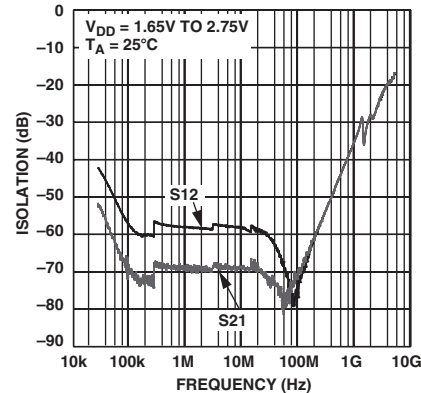

TPC 5. Isolation vs. Frequency over Supplies (RF1/RF2, ADG918)

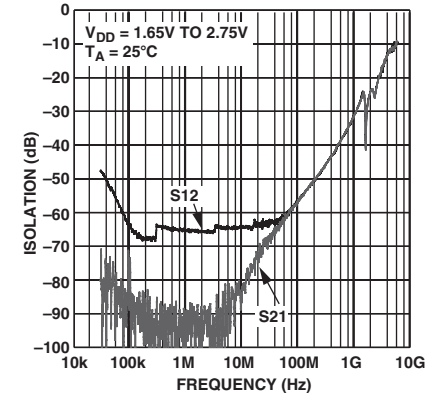

TPC 6. Isolation vs. Frequency over Supplies (RF1/RF2, ADG919)

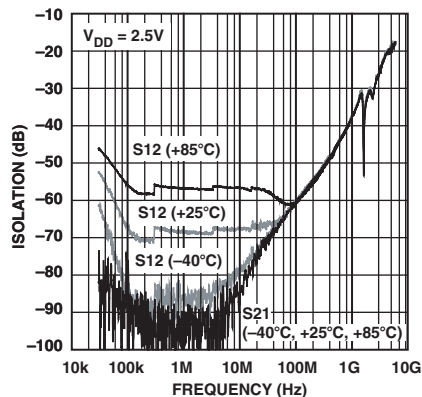

TPC 7. Isolation vs. Frequency over Temperature (RF1/RF2, ADG919)

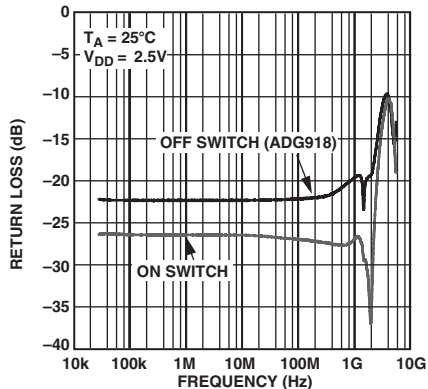

TPC 8. Return Loss vs. Frequency (RF1/RF2, S11)

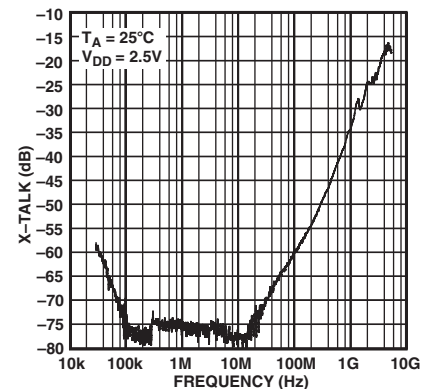

TPC 9. Crosstalk vs. Frequency (RF1/RF2, S12, S21)

# ADG918/ADG919

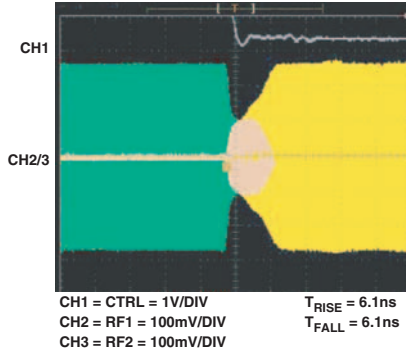

TPC 10. Switch Timing

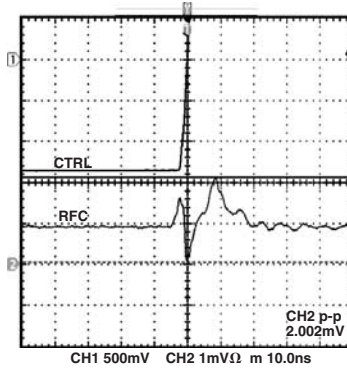

TPC 11. Video Feedthrough

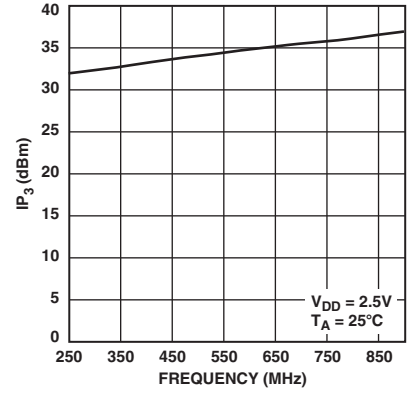

TPC 12.  $IP_3$  vs. Frequency

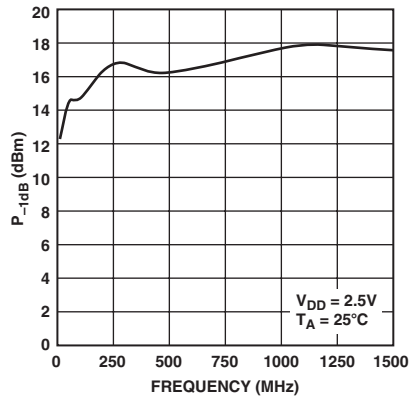

TPC 13.  $P_{-1dB}$  vs. Frequency

## Test Circuits\*

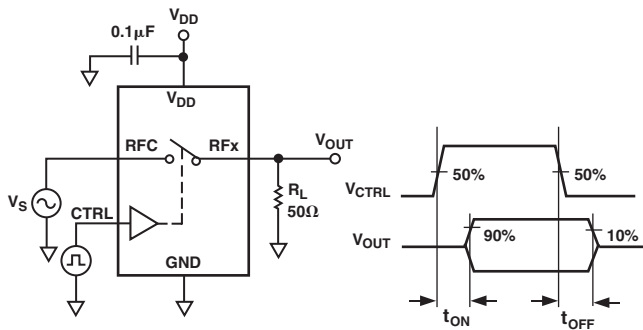

Test Circuit 1. Switching Timing:  $t_{ON}$ ,  $t_{OFF}$

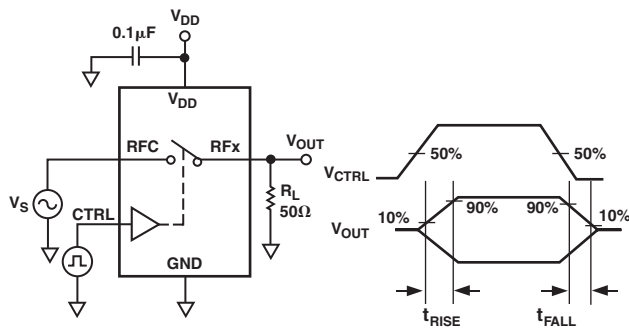

Test Circuit 2. Switch Timing:  $t_{RISE}$ ,  $t_{FALL}$

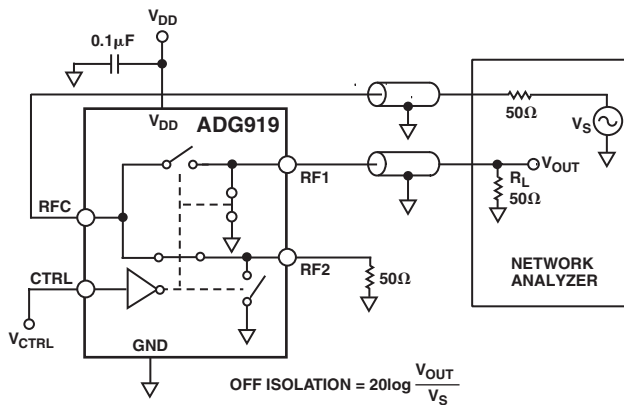

Test Circuit 3. Off Isolation

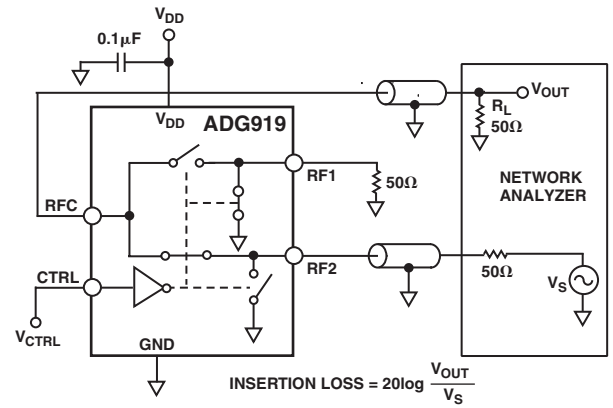

Test Circuit 4. Insertion Loss

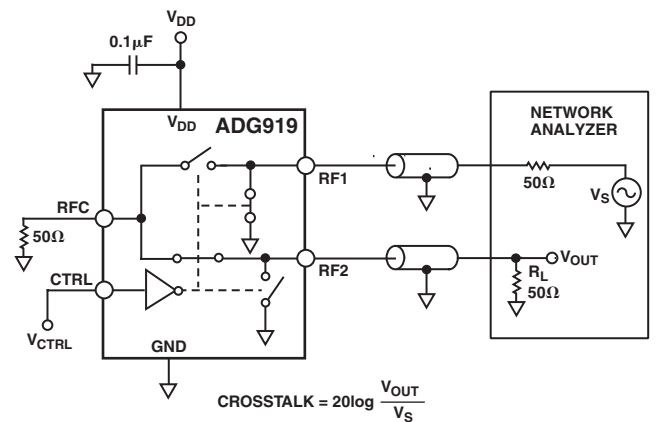

Test Circuit 5. Crosstalk

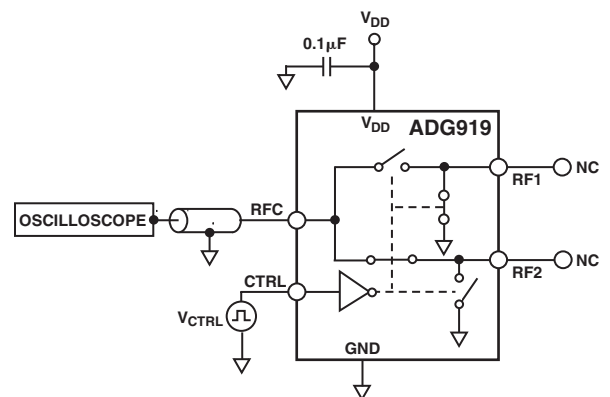

Test Circuit 6. Video Feedthrough

\*Similar setups for ADG918.

# ADG918/ADG919

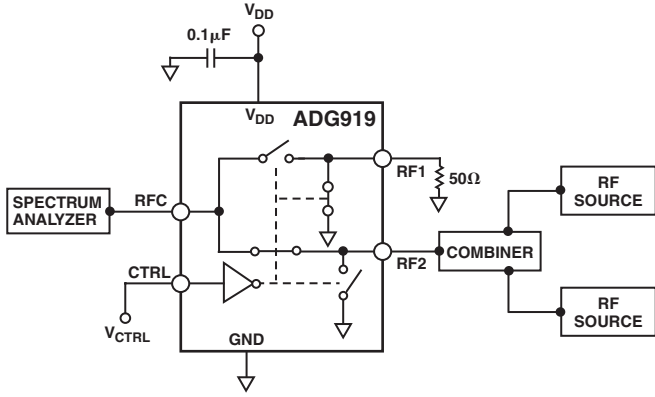

Test Circuit 7.  $IP_3$

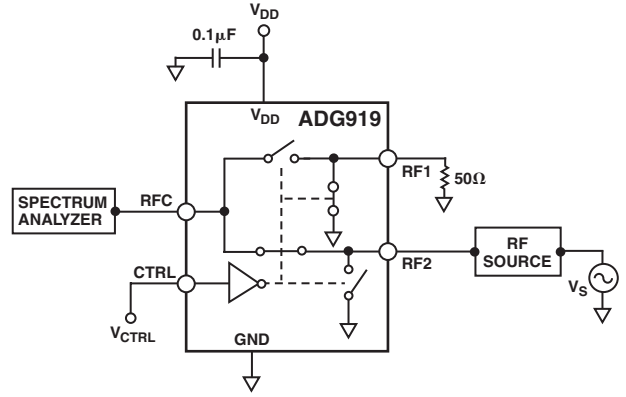

Test Circuit 8.  $P_{-1dB}$

## APPLICATIONS

The ADG918/ADG919 are ideal solutions for low power, high frequency applications. The low insertion loss, high isolation between ports, low distortion, and low current consumption of these parts make them excellent solutions for many high frequency switching applications. The most obvious application is in a transmit/receive block, as shown in the wireless metering block diagram in Figure 3.

Other applications include switching between high frequency filters, ASK generator, FSK generator, and antenna diversity switch in many tuner modules.

### Absorptive vs. Reflective

The ADG918 is an absorptive (matched) switch with 50 Ω terminated shunt legs, and the ADG919 is a reflective switch with 0 Ω terminated shunt legs to ground. The ADG918 absorptive switch has a good VSWR on each port, regardless of the switch mode. An absorptive switch should be used when there is a need for a good VSWR that is looking into the port but not passing the through signal to the common port. The ADG918 is therefore ideal for applications that require minimum reflections back to the RF source. It also ensures that the maximum power is transferred to the load.

The ADG919 reflective switch is suitable for applications where high off port VSWR does not matter and the switch has some other desired performance feature. It can be used in many applications, including high speed filter selection. In most cases, an absorptive switch can be used instead of a reflective switch, but not vice versa.

### Wireless Metering

The ADG918 can be used in wireless metering applications. It can be used in conjunction with the ADF7020 transceiver IC for a utility metering transceiver application, providing the required isolation between the transmit and receive signals.

The SPDT configuration isolates the high frequency receive signal from the high frequency transmit.

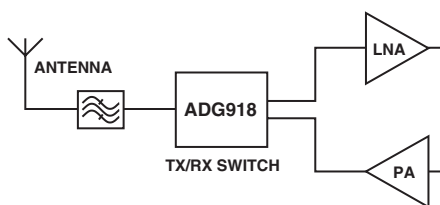

Figure 3. Wireless Metering

### Tuner Modules

The ADG918 can be used in a tuner module to switch between the cable TV input and the off-air antenna.

This part is also ideal for use as an antenna diversity switch, switching different antenna to the tuner.

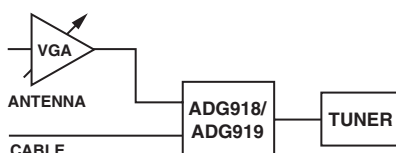

Figure 4. Tuner Modules

### Filter Selection

The ADG919 can be used as a 2:1 demultiplex to switch high frequency signals between different filters and also to multiplex the signal to the output.



Figure 5. Filter Selection

### ADG9xx EVALUATION BOARD

The ADG9xx evaluation board allows designers to evaluate the high performance wideband switches with a minimum of effort.

To prove that these devices meet the user's requirements, the user only requires a power supply and a network analyzer along with the evaluation board. An application note is available with the evaluation board and gives complete information on operating the evaluation board.

The RFC port (see Figure 6) is connected through a 50 Ω transmission line to the top left SMA connector J1. RF1 and RF2 are connected through 50 Ω transmission lines to the top two SMA connectors J2 and J3, respectively. A through transmission line connects J4 and J5 and this transmission line is used to estimate the loss of the PCB over the environmental conditions being evaluated.

The board is constructed of a 4-layer, FR4 material with a dielectric constant of 4.3 and an overall thickness of 0.062 inches. Two ground layers with grounded planes provide ground for the RF transmission lines. The transmission lines were designed using a coplanar waveguide with ground plane model using a trace width of 0.052 inches, clearance to ground plane of 0.030 inches, dielectric thickness of 0.029 inches, and a metal thickness of 0.0014 inches.

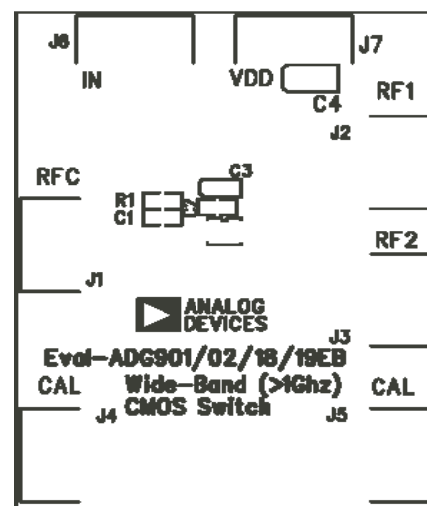
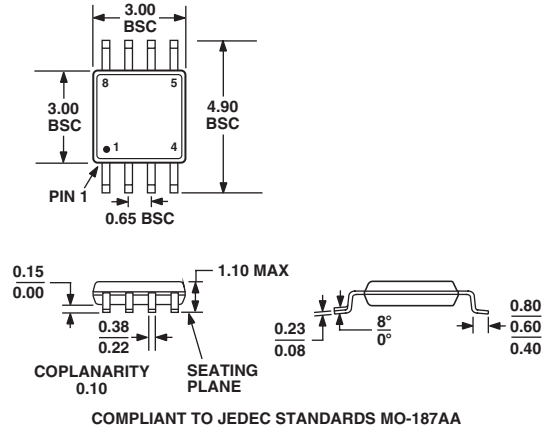

Figure 6. ADG9xx Evaluation Board Top View

## OUTLINE DIMENSIONS

### 8-Lead Mini Small Outline Package [MSOP] (RM-8)

Dimensions shown in millimeters



### 8-Lead Lead Frame Chip Scale Package [LFCSP] 3 mm × 3 mm Body (CP-8)

Dimensions shown in millimeters

