

NO	TITLE	PART NO	PCS	DWG NO	MATERIAL
1	BODY	QXBBJ08581	1		SAE 1141
2	STUD	QXBST08582	1		SAE 1040
3	P.BUSHING		1		PLASTIC
4	WASHER		1		
5	RUBBER BOOT		1		
6	S.G.FITTING	G/F3	1		

NO	MODIFICATION	DATE	NAME
1			
2			

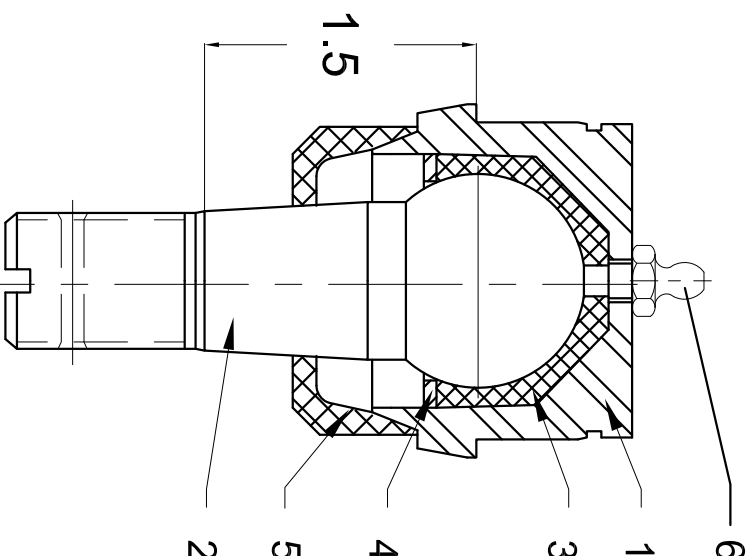

MILLIMETERS		INCHES	
DIM.	TOL.	DIM.	TOL.
XXX.XXX	±0.10	XXX.XXX	±0.005
XXX.XX	±0.25	XXX.XX	±0.010
XXX.X	±0.10	XXX.X	±0.020
XXX	±1.00	XXX	±0.040
DIMENSION	MM	INCH	
CAD	A.P.		
CAM	A.P.		

QXB Engineering™

Title: **BALL JOINT**

Dwg No. **QXB-BJ-0858**

Material: _____ Weight: _____

Scale: _____ Size: **A** Sheet no. _____

Assembly T/No. _____

NO	MODIFICATION	DATE	NAME
1			
2			

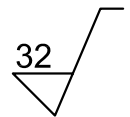
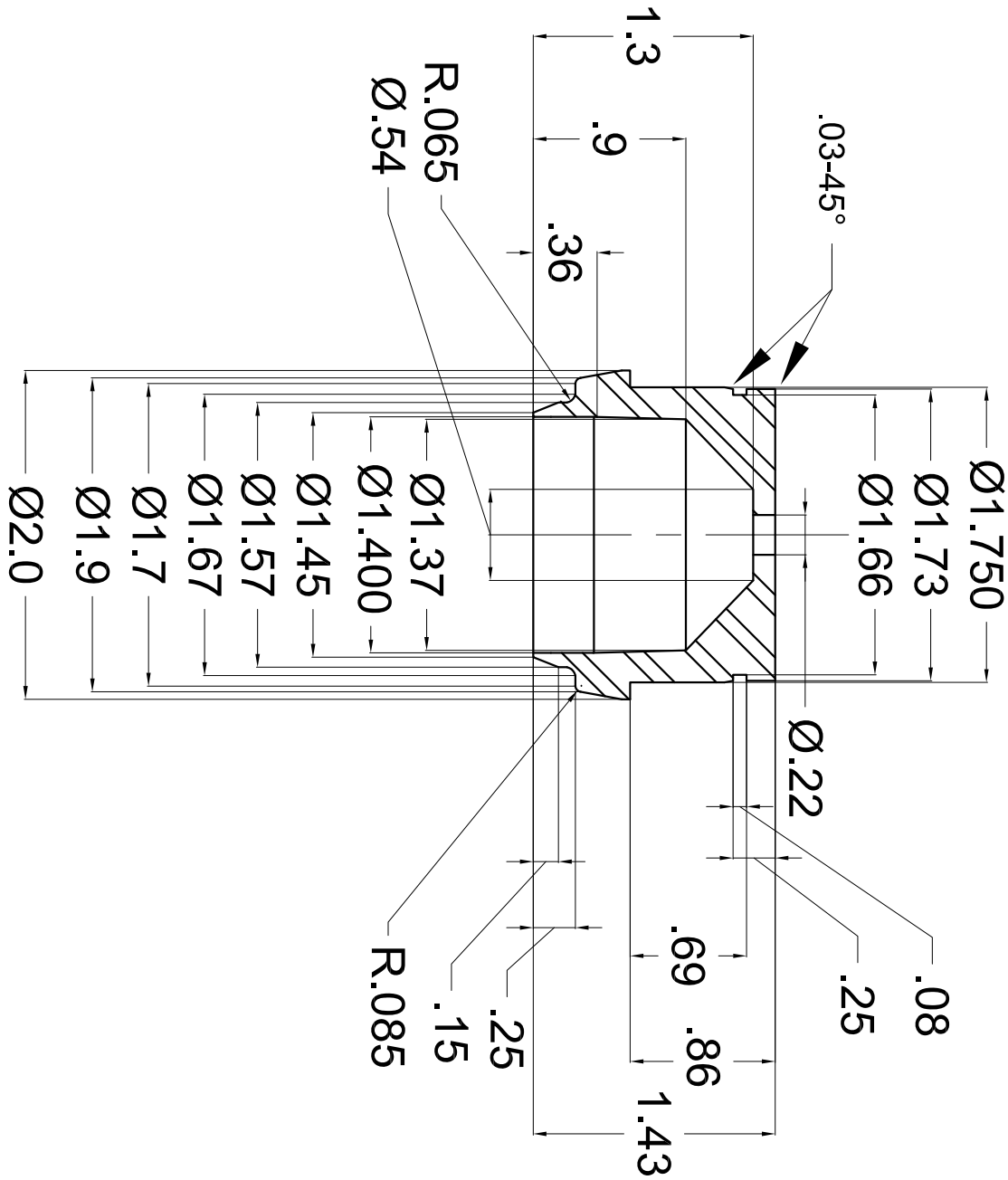

MILIMETERS		INCHES	
DIM.	TOL.	DIM.	TOL.
XXX.XXX	± 0.10	XXX.XXX	± 0.005
XXX.XX	± 0.25	XXX.XX	± 0.010
XXX.X	± 0.10	XXX.X	± 0.020
XXX	± 1.00	XXX	± 0.040
DIMENSION	MM	INCH	
CAD	A.P.		
CAM	A.P.		

QXB Engineering™

Title: **BALL JOINT**

Dwg No. **QXB BJ08581**

Material: SAE 1141

Weight:

Scale: Size: **A**

Sheet no.

Assembly T/No.

