

NO CHANGES.

01-24-08 OWNER REVISIONS
 NO. 1
 DATE
 REVISIONS
 BY

CONTRACTOR SHALL VERIFY ALL DIMENSIONS AT THE JOB SITE AND NOTIFY THE ARCHITECTS OF ANY DIMENSIONAL ERRORS, OMISSIONS OR DISCREPANCIES BEFORE BEGINNING OR FABRICATING ANY WORK
 DO NOT SCALE DRAWINGS

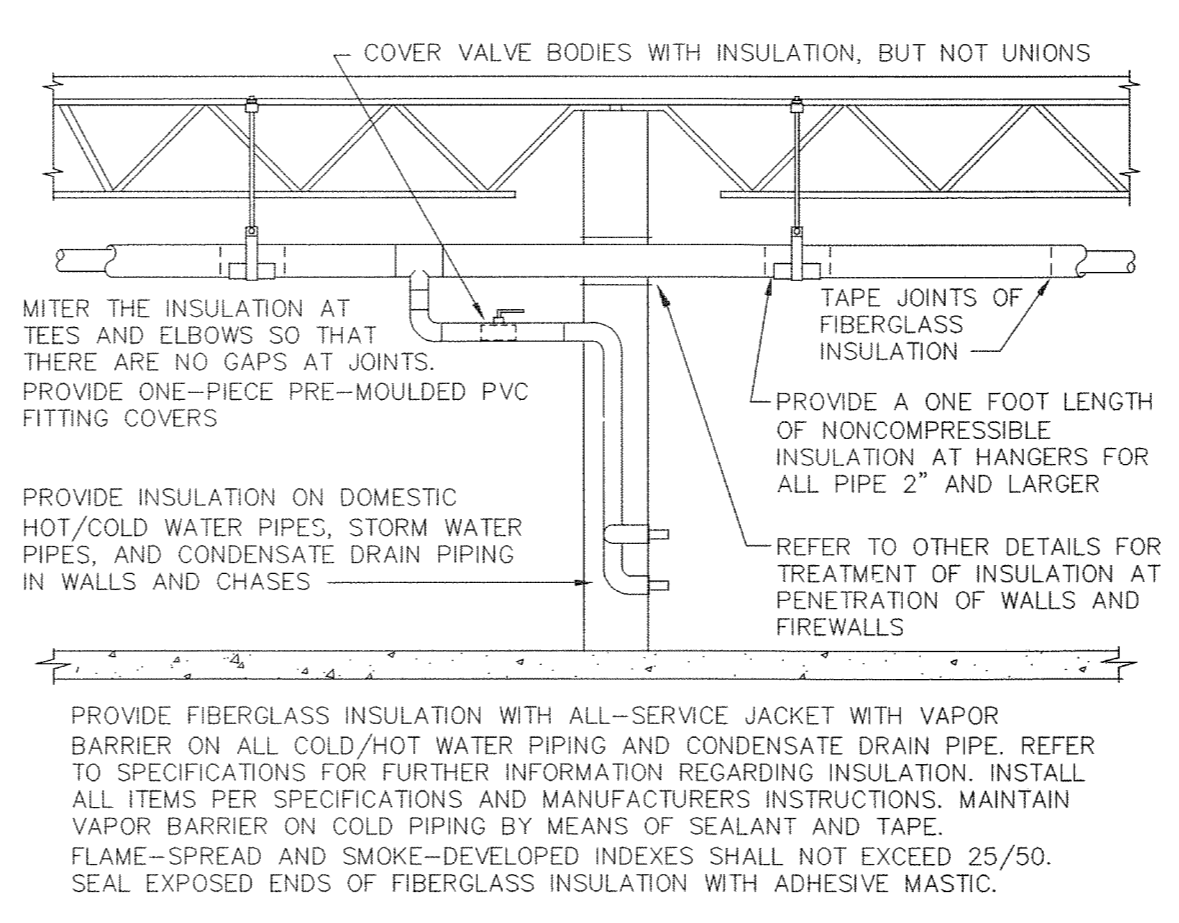
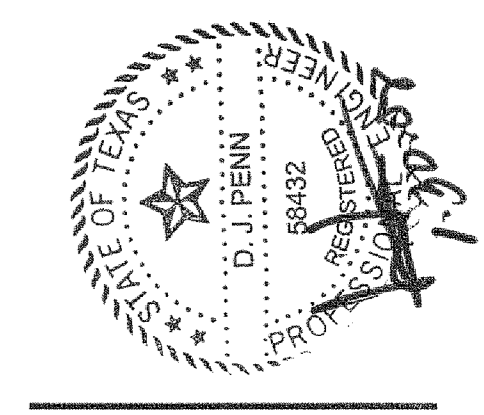

1 PIPE INSULATION
 SCALE: NO SCALE

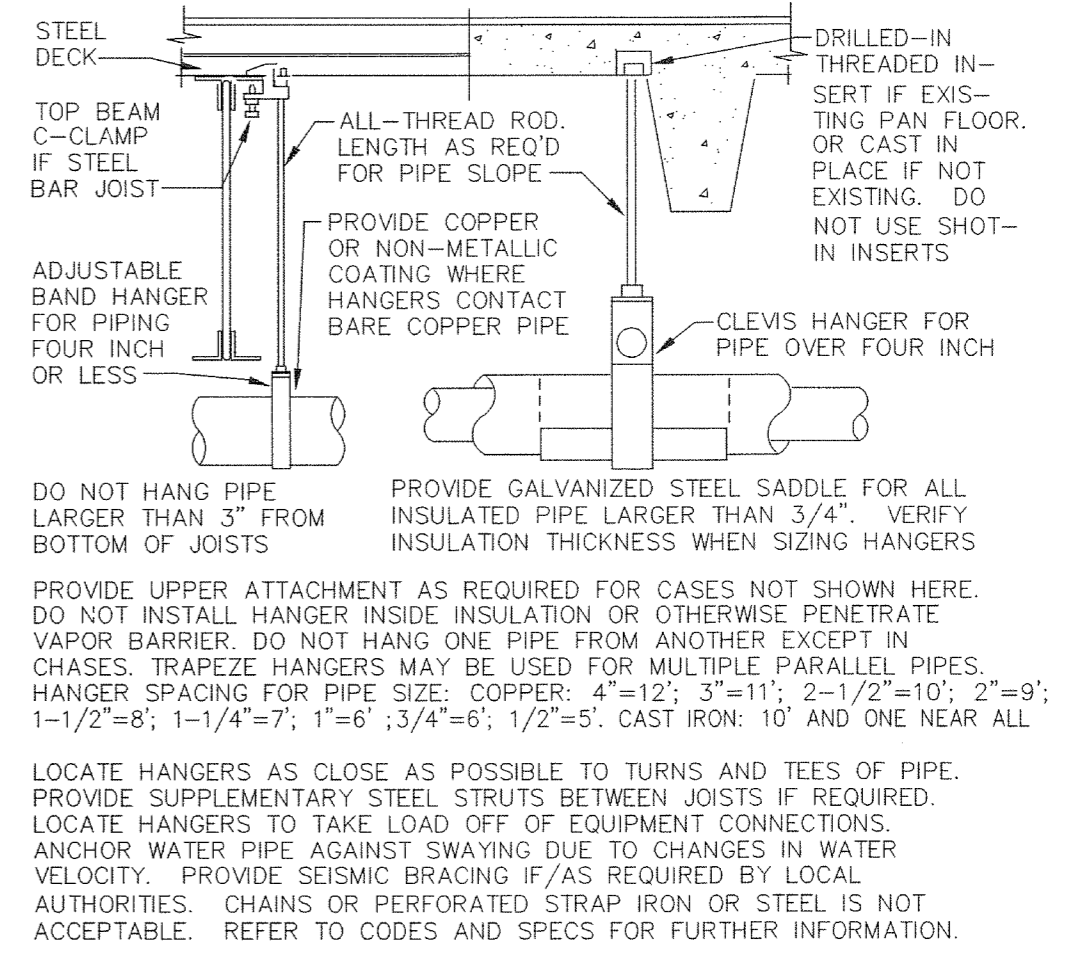

2 PIPE HANGER
 SCALE: NO SCALE

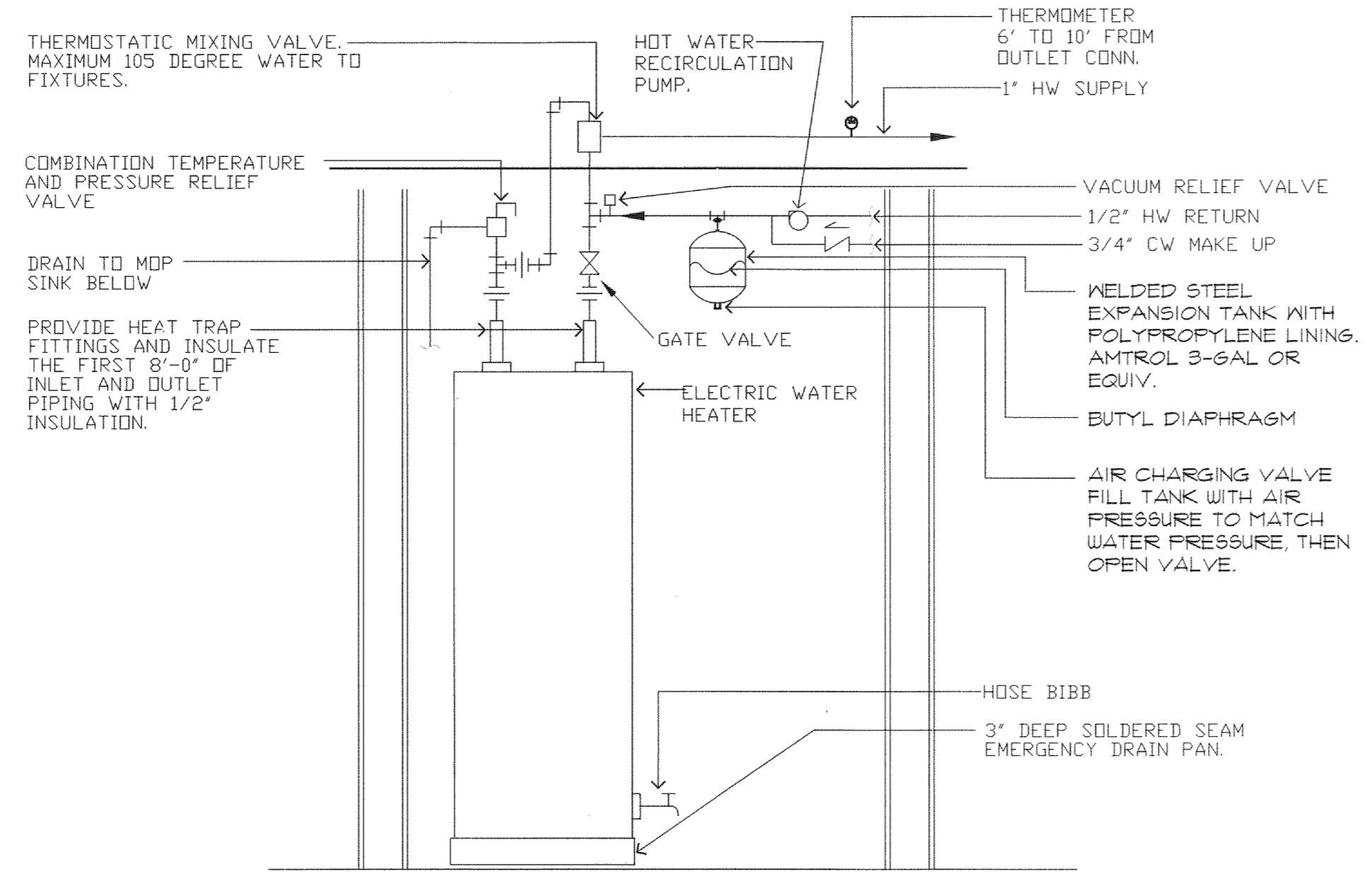

3 WATER HEATER DETAIL
 SCALE: NO SCALE

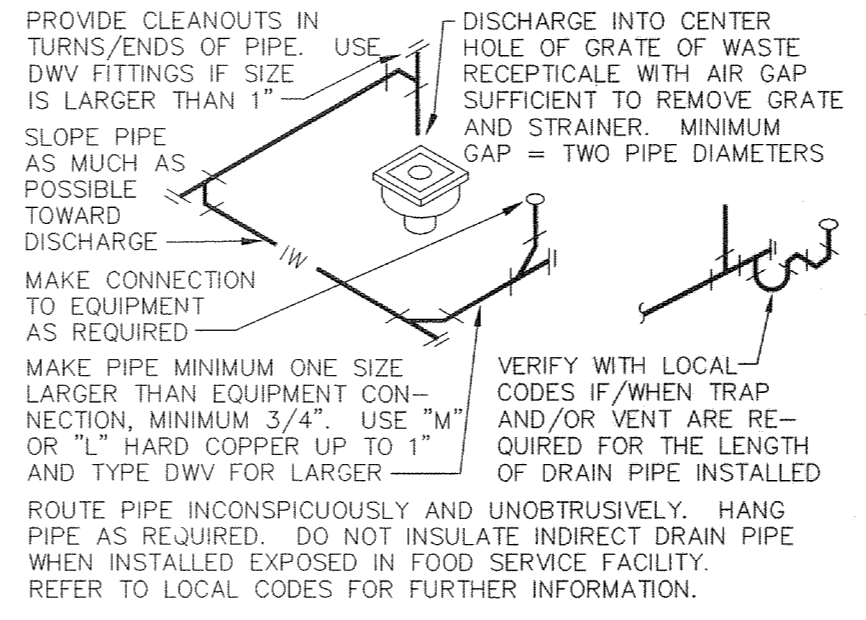

4 INDIRECT DRAIN
 SCALE: NO SCALE

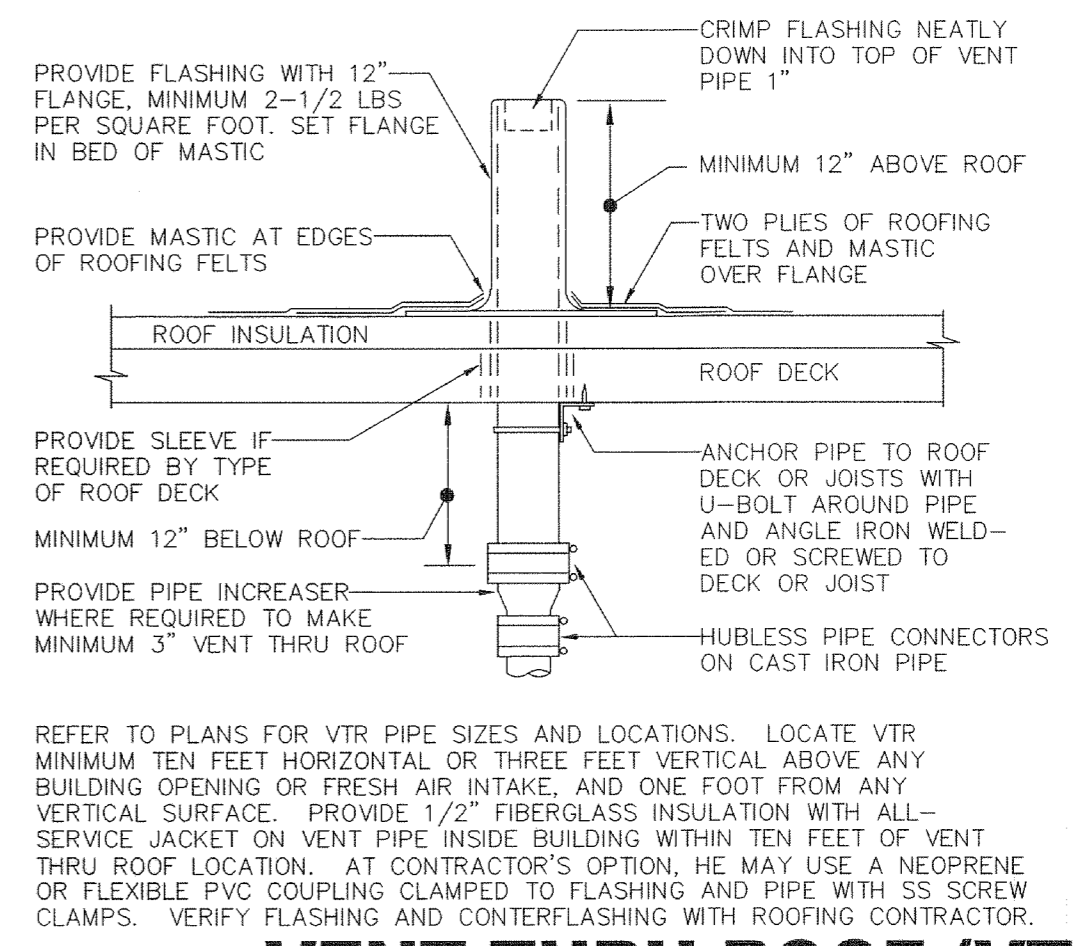

5 VENT THRU ROOF (VTR)
 SCALE: NO SCALE

Linear!
 the architecture of Kemery Brundige and Young
 5005 W. Royal Lane Suite 144
 Irving, TX 75063
 Phone: 972.929.9226
 Fax: 972.929.9061
 info@linear-architecture.com

**COOK CHILDREN'S
 PRIMARY CARE CLINIC**
 FT. WORTH, TX

JOB NUMBER
07.210

SHEET TITLE
**PLUMBING
 DETAILS**

SHEET NUMBER

P4

DATE OF ORIGINAL ISSUE
 © 29 NOVEMBER 2007