

Lecture 7.4

Work potential of a
chemical reaction

WORK POTENTIAL OF A CHEMICAL REACTION

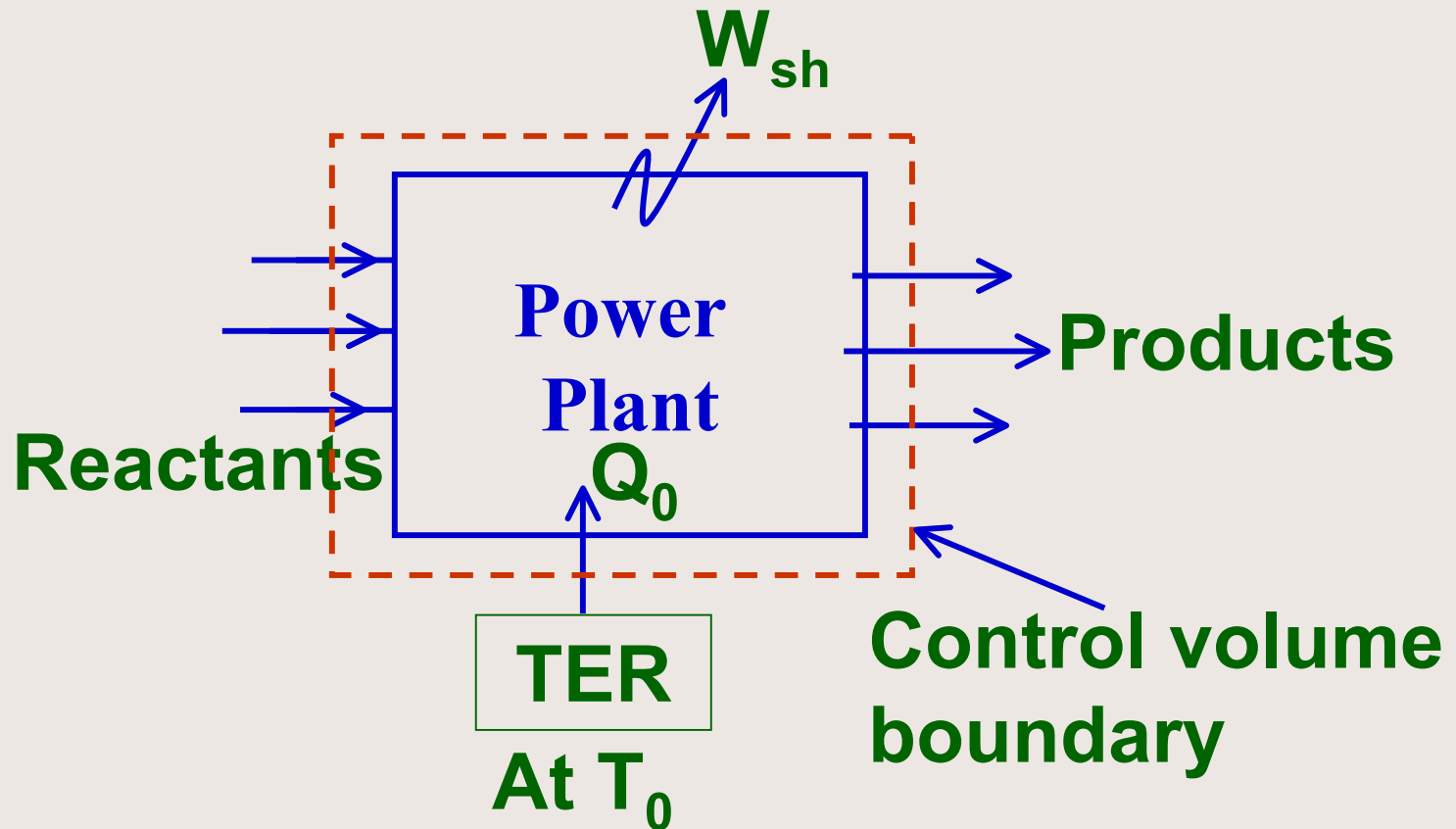

WORK POTENTIAL OF A CHEMICAL REACTION

Ist Law (neglecting ΔKE , ΔPE)

$$Q + H_R = H_P + W_{SH}$$

or

$$Q + \sum_R h_i N_i = W_{SH} + \sum_P h_i N_i$$

IInd Law

$$\sigma = \sum_P N_i S_i - \sum_R N_i S_i - \frac{Q}{T_0}$$

WORK POTENTIAL OF A CHEMICAL REACTION

Eliminating Q between the above two equations

$$W_{SH} = \sum_R h_i N_i - \sum_P h_i N_i + T_0 \left\{ \sum_P N_i s_i - \sum_R N_i s_i - \sigma \right\}$$

$$= \sum_R (h_i - T_0 s_i) N_i - \sum_P (h_i - T_0 s_i) N_i - T_0 \sigma$$

$$= \sum_R b_i N_i - \sum_P b_i N_i - T_0 \sigma$$

$$W_{Sh,rev} = \sum_R b_i N_i - \sum_P b_i N_i$$

WORK POTENTIAL OF A CHEMICAL REACTION

$$W_{\text{sh rev}} = \left\{ \begin{array}{l} \text{Total} \\ \text{availability of} \\ \text{reactants} \\ \text{entering CV} \end{array} \right\} - \left\{ \begin{array}{l} \text{Total} \\ \text{availability of} \\ \text{products} \\ \text{leaving the CV} \end{array} \right\}$$

When would $W_{\text{sh,rev}}$ be maximum?

$$T_R = T_P = T_0$$

And for both the reactants & the products

$$\therefore B_i = h_i - T_0 S_i = g_i$$

$$\Rightarrow W_{\text{max}} = \sum_R g_i N_i - \sum_P g_i N_i = -\Delta G_r$$

MAX. WORK OF A CHEMICAL REACTION

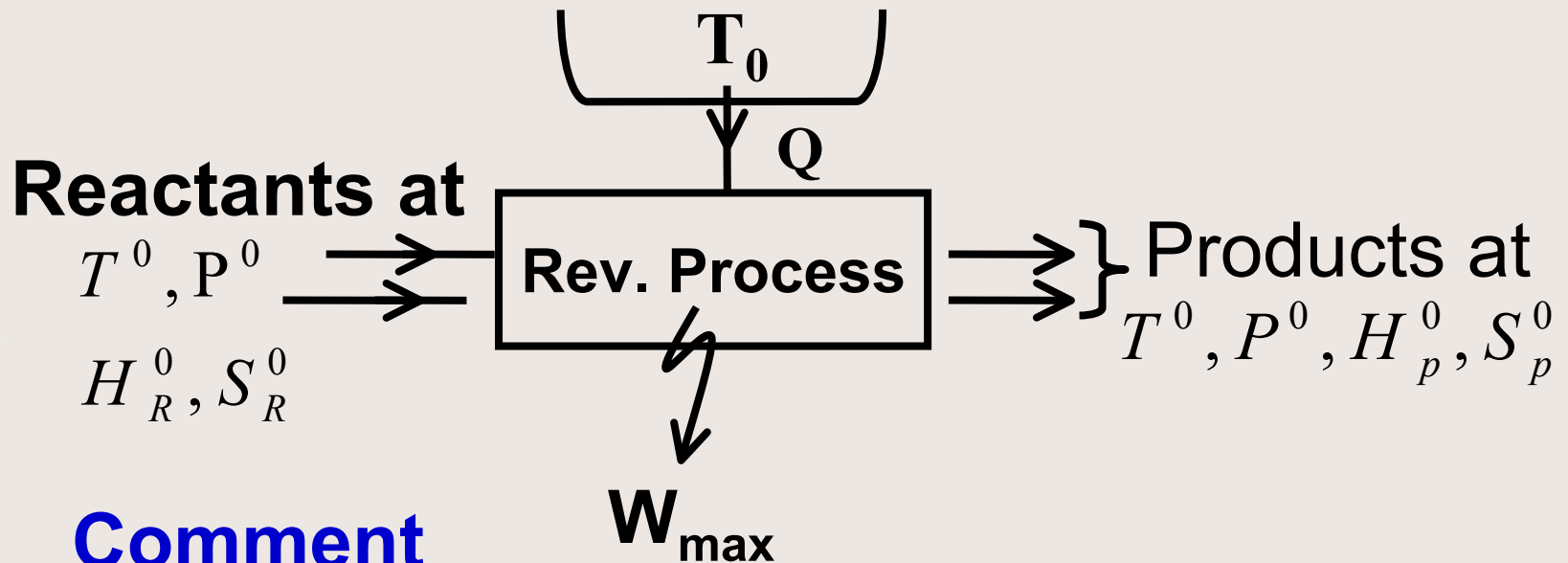

Comment

Compare with H.H.V. = $-\Delta H_r$

$$\frac{W_{\max}}{HHV} \approx 1 \quad ?$$

Example

Determine the second law efficiency of the process of combustion of methane at standard* conditions to produce steam at 500 K using stoichiometric proportions of air.

SOLUTION

Actual Process

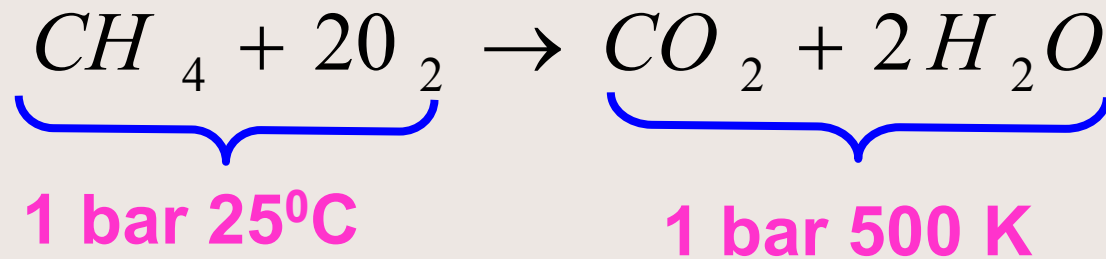

$$\Delta h_r = (h_{CO_2} + 2h_{H_2O}) - (h_{CH_4} + 2h_{O_2})$$

SOLUTION

$$\begin{aligned} &= \{ -393522 + 8314 + 2(-241827 + 6920) \} \\ &\quad - (-74873) \\ &= -780149 \text{ kJ} \end{aligned}$$

HV of 1 kmol of fuel = 780149 kJ

SOLUTION

Reversible Process

$$W_{\max} = -\Delta G_r \quad \text{at standard conditions}$$

$$= -\left\{g_{CO_2} + 2g_{H_2O} - g_{CH_4} - 2g_{O_2}\right\}$$

$$= -(-394374 + 2 \times (-228583) + 50751 - 0)$$

$$= 800789 \quad \text{kJ}$$

SOLUTION

∴ Second Law Efficiency

$$\psi = \frac{\text{work equivalent of } HV}{W_{\max}}$$

$$= \frac{780149 (500 - 298)}{500 \times 800789} = 0.394$$

Achieving Reversible “Combustion”

Van't Hoff's Equlbm. Box

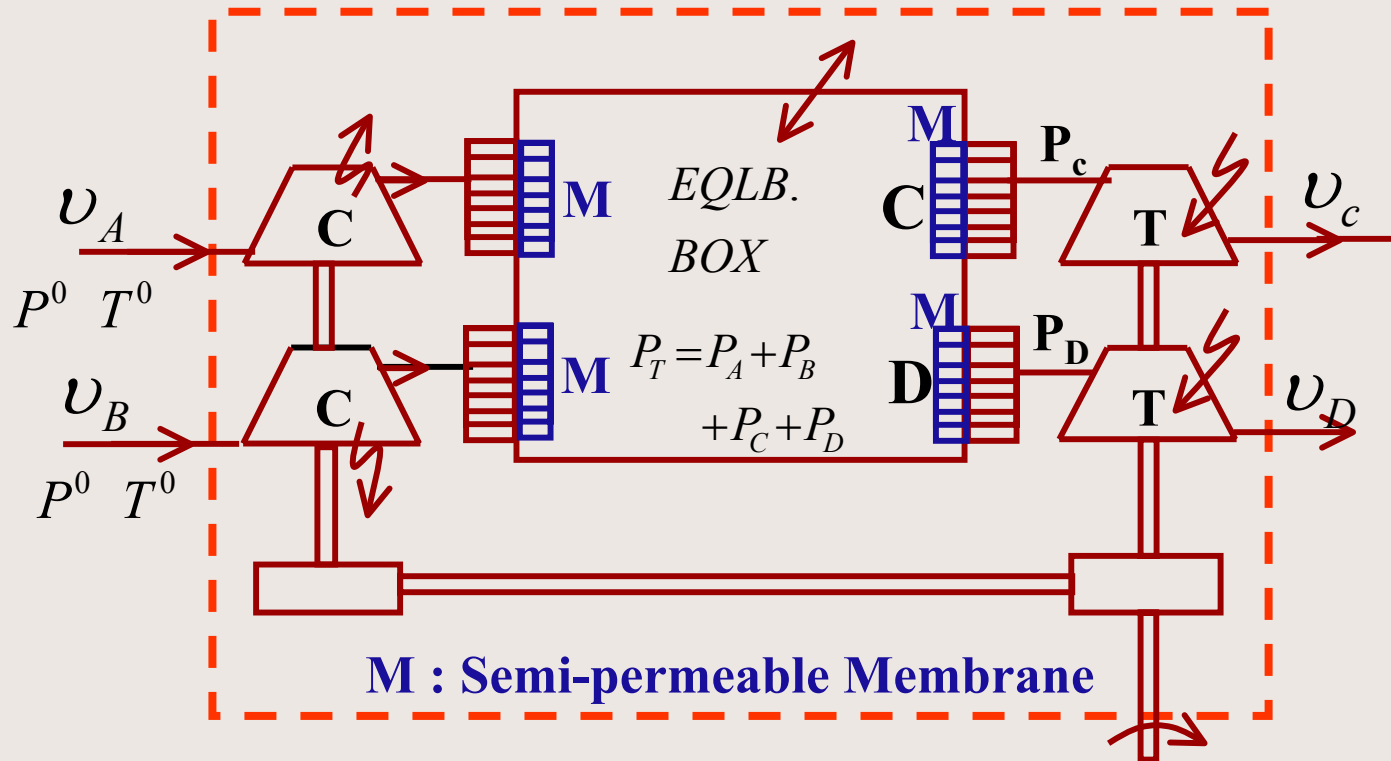

C : comp. **Rev. isothermal process**
T : turb

Achieving Reversible “Combustion”?

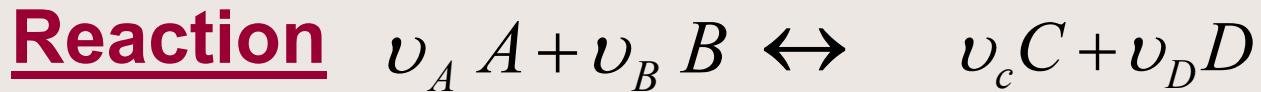

→ Ensuring proper inflow & outflow at steady rate, mol. Fractions & P.P. inside the box remain unchanged

$$W_{\max} = \sum \text{work from all devices} = -\Delta G^0$$

FUEL CELLS

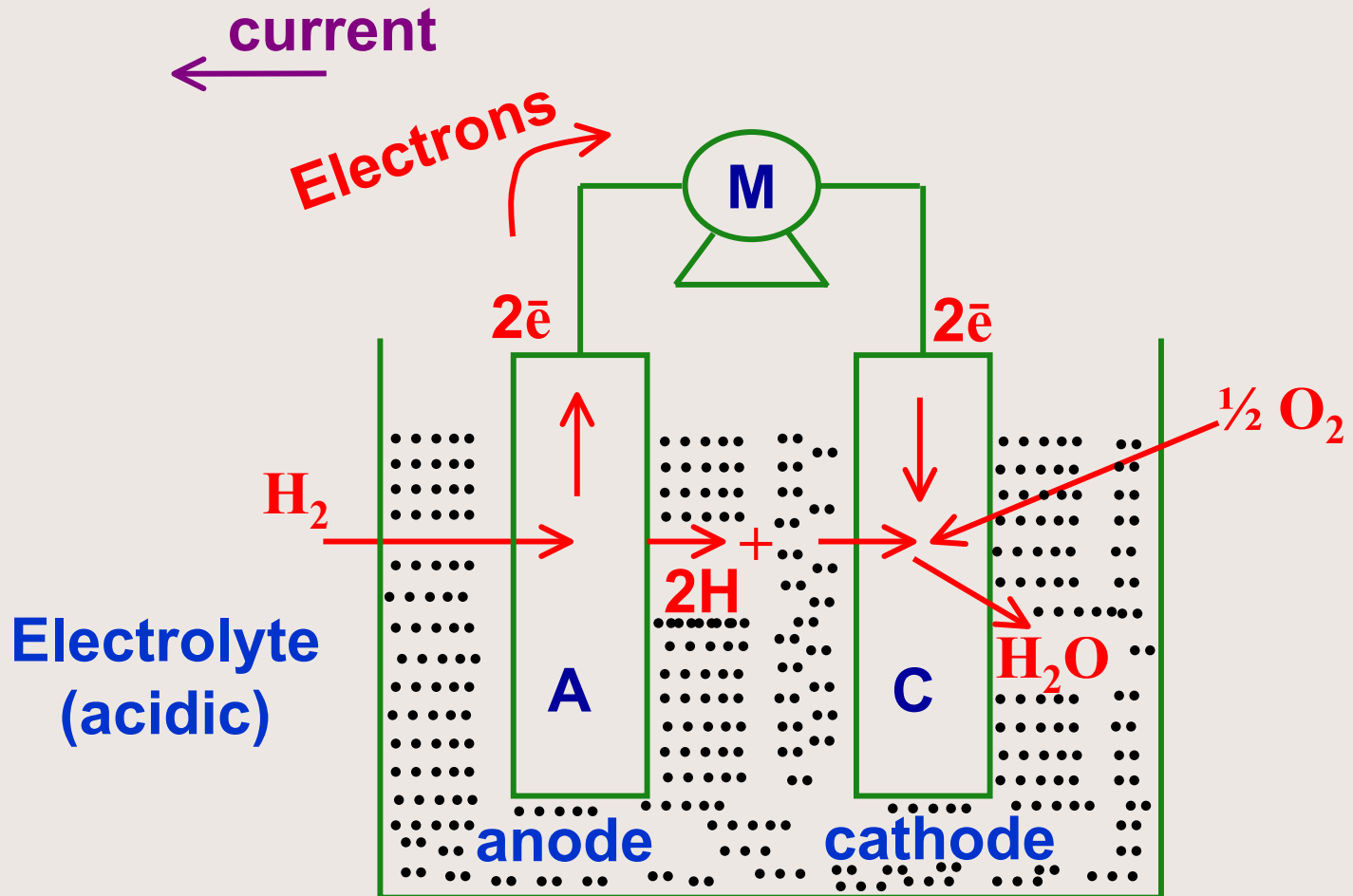

FUEL CELLS

Reactions

Anode

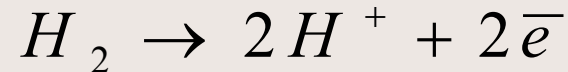

Cathode

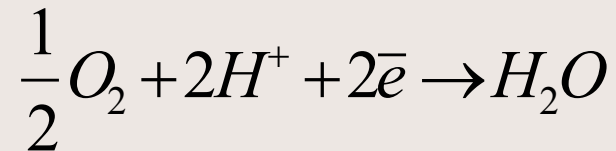

**Total
Cell Reaction**

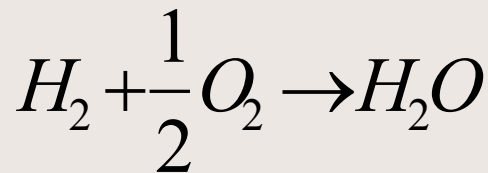

FUEL CELLS

**Electrodes must be porous
(permeable to gas)**

**Steady flow of H₂, O₂ and H₂O
{other fuels also being tried}**

{Thermo-mech.} $\eta < \eta_{carnot}$

FUEL CELLS

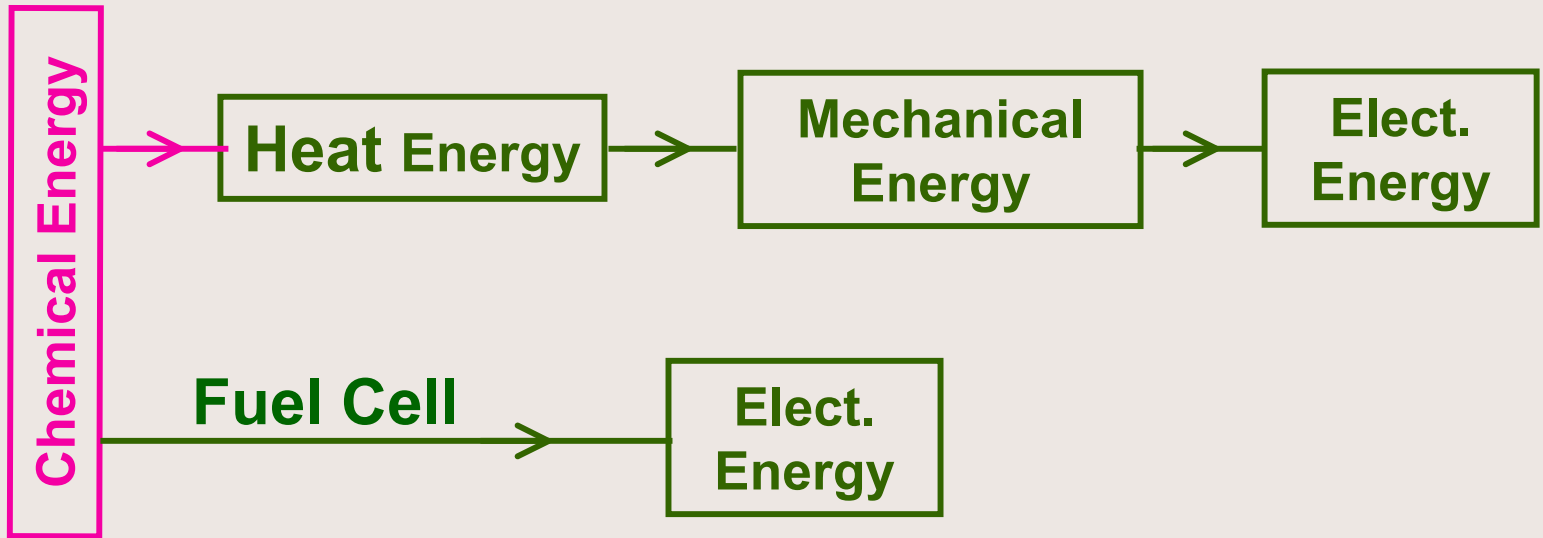

{Electro Chemical}

<No Carnot Cycle limitation>

A spiral-bound notebook with a white page and a brown cover. The spiral binding is on the left side. The text "End of Lecture" is written in green on the page.

End of Lecture