

Advanced Thermodynamics

Prof. P.L.Dhar

I.I.T.Delhi

BASIC CONCEPTS

What is thermodynamics? Its scope ?

Need for a precise formulation of basic concepts & improvement in its mathematical basis—various attempts.

Macroscopic & Microscopic View

Concept of Quantitative Measurement

----- standards

----- any quantitative measurement would involve a method by which we recognise the three cases :

$A > B$; $A < B$; $A = B$

Conversely : To define a new quantity, we need to set up an experimental. method on above lines.

BASIC CONCEPTS

OBJECT, ISOLATION, BOUNDARIES



Need for idealisation

Since by definition an object is something that can be isolated → no spontaneous changes should occur in it (e.g. Radioactive salt can't be an object).

Such an isolated object undergoing no change at all is said to be in equilibrium.



Equilibrium Thermodynamics

BASIC CONCEPTS

INTERACTION – Its general features

❖ Establishing
interaction

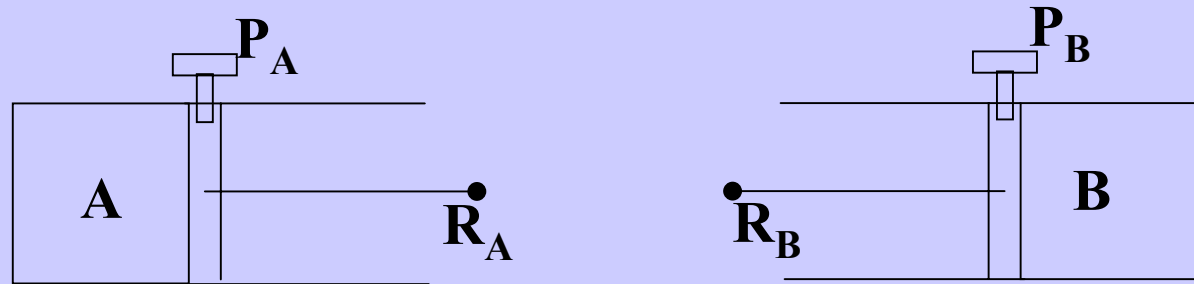

❖ Mode of
interaction

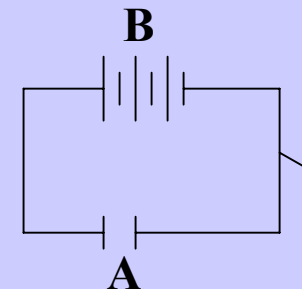
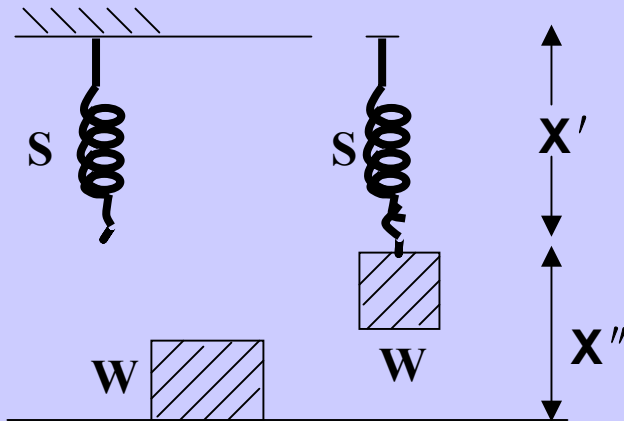
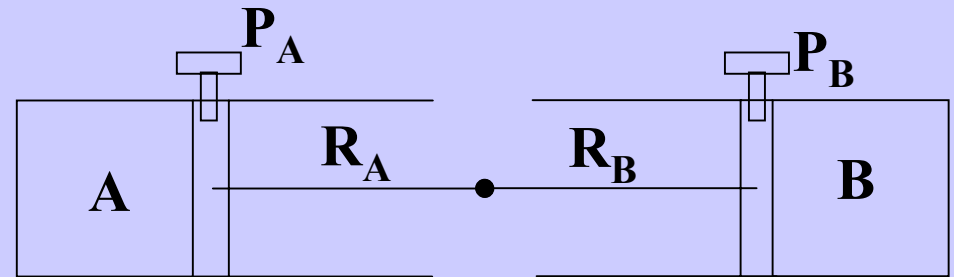

BASIC CONCEPTS

❖ Condition of interaction

loss of independence → interdependence

Conditions of Interaction $X' + X'' = H$ ----- (1)

$$Q' + Q'' = \text{Const} \text{ -----}$$

$$\textcircled{2} V' + V'' = \text{Const} \text{ ----}$$

(3)

Alternative formulations

e.g. If $S = l nV$ eq (2) would transform to $e^{s'} + e^{s''} = \text{Const.}$

BASIC CONCEPTS

STATE of an OBJECT, PROPERTY

Intrinsic macroscopically observable characteristics.

Condition of an object as described by its properties.

Choice of properties is not unique.

Relationship between the properties of an Object → EQ.OF STATE

e.g. $\frac{Q}{V} = C$; $P.V. = RT$

BASIC CONCEPTS

Generalised Coordinates

Variables preferred in defining the state of an object

Q, h or **V, h** ?

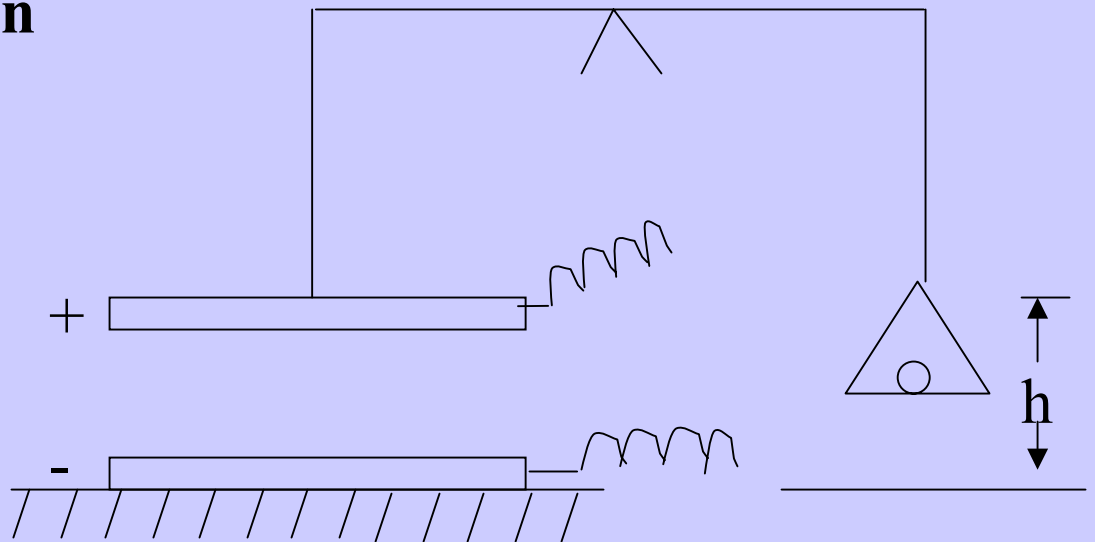

Capacitor balance

BASIC CONCEPTS

Orthogonal Variables :

That can be changed arbitrarily without affecting the other .

Q, h or V, h ?

Generalised Coordinates : a set of variables that are orthogonal on one another.

For various interactions we can identify generalized coordinates, e.g.

$X, V, Q, N_i, M, \dots\dots$

Basic Concepts

Recap

- **Quantitative Measurement**
- **Object , Isolation, Boundaries**
- **Equilibrium**
- **Interaction - its general features**
- **State , property, Equation of state**
- **Generalised coordinates**

BASIC CONCEPTS.....

Generalised Force

Principle of Causality : for every 'effect' there is a cause

**Cause behind the effects of interaction \equiv
Generalised Force**

How to Quantify it ?

Three possible outcomes of any interaction are

$$dx' > 0 ; dx'' < 0 \text{ -----}$$

$$(i) \quad dx' < 0 ; dx'' > 0 \text{ -----}$$

$$(ii) \quad dx' = 0 ; dx'' = 0 \text{ ----- (iii)}$$

BASIC CONCEPTS

Generalised Force

By close observation of the interaction, it is possible to identify property f of the objects such that :

$$\begin{array}{ll} dx' > 0 ; dx'' < 0 & \text{-----} \quad f' < f'' \quad \text{-----} \quad \text{(i)} \\ \text{(i)} \quad dx' < 0 ; dx'' > 0 & \text{-----} \quad f' > f'' \quad \text{-----} \\ \text{(ii)} \quad dx' = 0 ; dx'' = 0 & \text{-----} \quad f^{(ji)} = f'' \quad \text{-----} \\ \text{(iii)} & \text{(iii)} \end{array}$$

We call this Quantity f as the Gen. Force

Condition (iii) above \equiv equilibrium between objects

BASIC CONCEPTS

Determine Generalised force for various interaction

Battery – capacitor

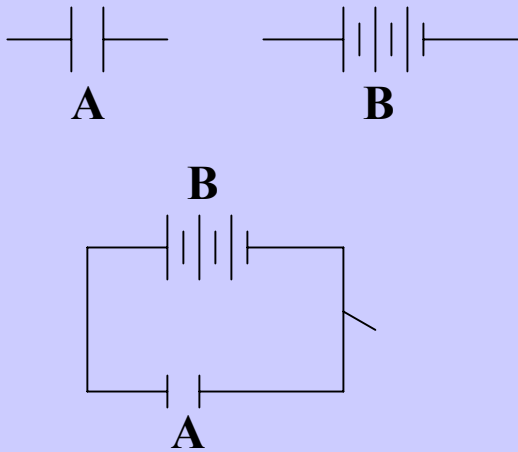

Compressible fluid

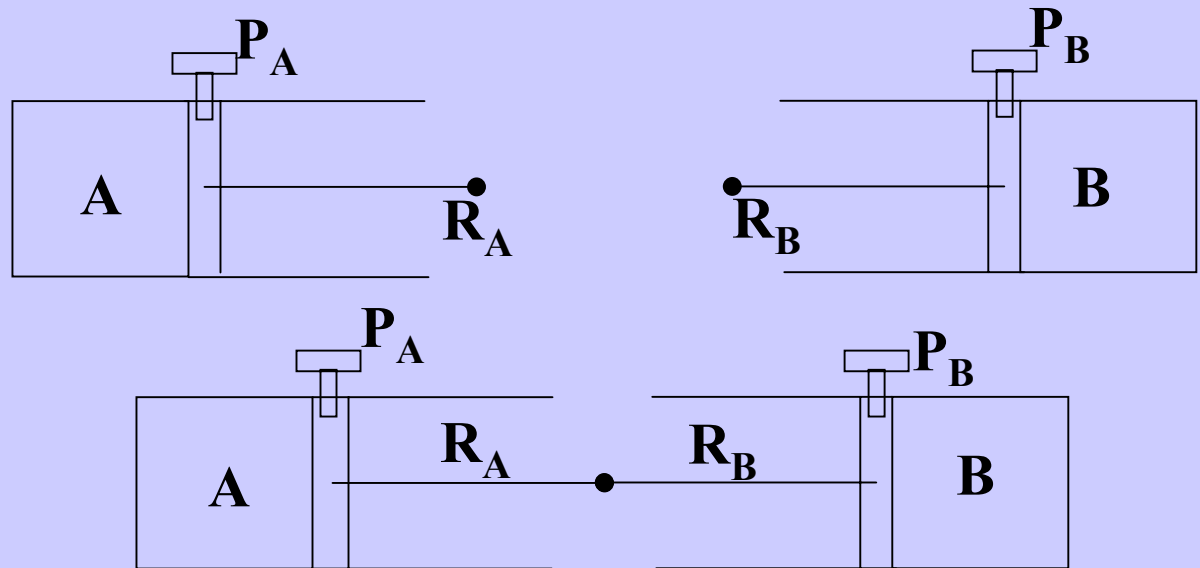

Surface – film : σ

Spring – weight : F

BASIC CONCEPTS

SYSTEM	GEN. FORCE	GEN. CO-ORD.
Mechanical (Linear / elastic)	Tension, T (N)	Extension, L (m)
Mechanical (rotational)	Torque M (N-m)	Angle of rotation, θ (radians)
Mechanical (expansion)	Pressure, (-P) (N/m²)	Volume, V (m³)
Physico- Chemical (Surface- extension)	Surface Tension, σ (N/m)	Surface Area, A (m²)

Electrical	E.M.F. V (volt)	Charge, Q (coulomb)
Electric Polarisation	Elec. field, E (volt/m)	Polarisation, P (coulomb-m)
Magnetic (magnetization)	Mag. field, H (Amp / m)	Magnetisation, M (A m²)

BASIC CONCEPTS

Generalised Force

Summary

Generalised Force is the cause behind the effects of interaction

Mode of interaction decides the generalised force

Equilibrium is essential for measurement of generalised force

**Principle of Transitivity : $f' = f''$ & $f'' = f' ''$
 $\Rightarrow f' = f' ''$**