

1990 Hong Kong Advanced Level Examination
AL Physics
Multiple Choice Question

1. The formula $T^2 = 4\pi^2 l/g$ is used to calculate the acceleration due to gravity g .
 If the maximum percentage error of $l = 2\%$
 the maximum percentage error of $T = 5\%$,
 then the maximum percentage error for g will be
- A. 3%.
 B. 8%.
 C. 12%.
 D. 23%.
 E. 27%.
2. When a man is running due north, he feels that the wind is blowing towards him from the east. What is the actual direction of the wind?
- A. from the east
 B. from north-east
 C. from south-east
 D. from south-west
 E. from north-west
3. A uniform rope has a length l and a mass m . It is held stationary with $4/5$ of the length of the rope lying on a smooth horizontal table surface and with the remaining $1/5$ hanging freely over the edge. The minimum work required to pull the whole rope onto the table surface is
- A. $0.01 mgl$.
 B. $0.02 mgl$.
 C. $0.1 mgl$.
 D. $0.2 mgl$.
 E. mgl .

4.

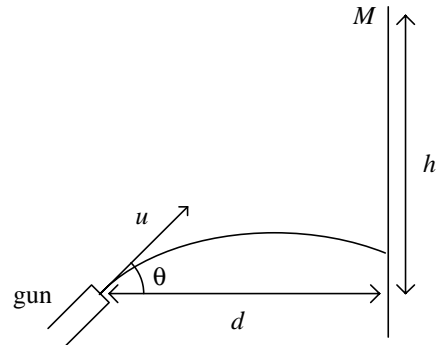

A hunter aims his gun at a target which is at rest at point M , and his gun makes an angle θ with the horizontal. Exactly as the gun is fired the target drops from M with zero initial velocity. If the bullet is to strike the target, the angle θ depends on

- (1) u , the initial speed of the bullet.
 (2) h , the vertical height of the target above the level of the gun.
 (3) d , the horizontal distance of the gun from the target.
- A. (1), (2) and (3)
 B. (1) and (2) only
 C. (2) and (3) only
 D. (1) only
 E. (3) only

5.

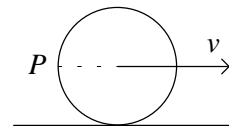

A wheel rolls horizontally along the ground without slipping. The speed of the centre of mass of the wheel is v . The instantaneous speed of point P relative to the ground is

- A. zero.
 B. v .
 C. $v\sqrt{2}$.
 D. $2v$.
 E. $4v$.

6. A spring of unstretched length 10.0 cm, has one end fixed to the ceiling. A mass is suspended at the other end, and the extension so produced is 3.0 cm. When the mass is set to rotate in a horizontal circular path the length of the spring is 16.0 cm. The angle between the spring and the vertical is
- A. 15°.
B. 30°.
C. 45°.
D. 60°.
E. 75°.
7. An object moves vertically with simple harmonic motion just behind a wall. From the other side of the wall the object is visible in each cycle for 2.0 s and hidden behind the wall for 6.0 s. The maximum height reached by the object relative to the top of the wall is 0.30 m. The amplitude of the motion is
- A. 0.18 m.
B. 0.51 m.
C. 0.60 m.
D. 1.02 m.
E. 1.20 m.
8. Two wires X and Y of the same length and of the same elastic metal are each stretched to the same tension. The diameter of wire X is half that of wire Y . The ratio of the elastic potential energy stored in wire X to that stored in wire Y is
- A. 1 : 1.
B. 1 : 2.
C. 1 : 4.
D. 2 : 1.
E. 4 : 1.
9. Two spherical soap bubbles of the same material have radii 40 mm and 60 mm. They coalesce so that they share a common surface. If the radii of the bubbles remain unchanged, the radius of curvature of the common surface is
- A. 40 mm.
B. 50 mm.
C. 60 mm.
D. 120 mm.
E. 240 mm.
10. A piston of radius r and length l is pushed through a cylinder covered with a thin layer of oil of viscosity η . The effective thickness of the oil layer is d . When the speed of the piston is u , the resistive force it experiences is:
- A. $2\pi r l \eta u/d$.
B. $2\pi r l \eta u d$.
C. $\pi r^2 l \eta u/d$.
D. $\pi r^2 l \eta u d$.
E. $2\pi r l \eta u$.
11. In fluid dynamics, which of the following assumptions is/are used in deriving Bernoulli's equation?
- (1) The fluid undergoes streamline flow.
(2) The fluid is compressible.
(3) Viscous forces act on the fluid.
- A. (1), (2) and (3)
B. (1) and (2) only
C. (2) and (3) only
D. (1) only
E. (3) only
12. Which of the following will decrease when the temperature increases?
- (1) the surface tension of a liquid
(2) the viscosity of a liquid
(3) the drift velocity of electrons in a metal
- A. (1), (2) and (3)
B. (1) and (2) only
C. (2) and (3) only
D. (1) only
E. (3) only
13. Container X holds pure hydrogen gas while container Y holds pure oxygen gas. If the hydrogen molecules in X have the same r.m.s. speed as the oxygen molecules in Y , which of the following conclusions may be drawn?
- A. The gas in X has a higher temperature than Y .
B. The gas in X has a higher pressure than Y .

- C. The gas in Y has a higher temperature than X .
 D. The gas in Y has a higher pressure than X .
 E. The gases in X and Y are at the same temperature.

14. A fixed mass of an ideal gas is enclosed in a cylinder by a piston. When the piston is pushed quickly into the cylinder, which of the following physical properties of the gas will increase?

- (1) pressure
 (2) temperature
 (3) internal energy

- A. (1), (2) and (3)
 B. (1) and (2) only
 C. (2) and (3) only
 D. (1) only
 E. (3) only

15. A rubber band is of unstretched length l and force constant k . When it is stretched to a length $2l$, the speed of transverse waves on it is v . What will be the speed of transverse waves when it is stretched to a length $3l$?

- A. v
 B. $v\sqrt{2}$
 C. $3v/2$
 D. $v\sqrt{3}$
 E. $2v$

- 16.

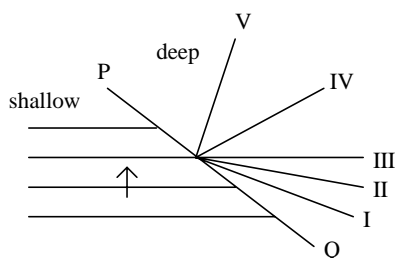

The figure shows wave crests moving in the direction of the arrow towards the interface PQ between a shallow region and a deep region as shown in the figure above. Which of the lines shown may represent one of the wave crests in the deep region?

- A. I
 B. II

- C. III
 D. IV
 E. V

- 17.

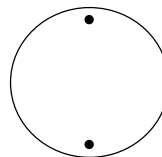

A disc with a spot on it rotates at a constant speed in a darkened room. A student shines a stroboscopic lamp on it. When the flashing rate is 8 flashes per second, the disc appears stationary with two spots on it as shown. When the flashing rate is reduced to 2 flashes per second, the disc would appear to be stationary with

- A. no spot.
 B. one spot.
 C. two spots.
 D. four spots.
 E. eight spots.

18. Which of the following represent the approximate noise levels

- (i) in a quiet school library?
 (ii) near the airport when an aircraft is taking off and flying overhead?

(i) (ii)

- A. 30 dB 60 dB
 B. 60 dB 90 dB
 C. 30 dB 90 dB
 D. 90 dB 60 dB
 E. 60 dB 30 dB

19. The intensity of a sound wave is proportional to the square of the amplitude of the wave. If two waves of the same frequency are superimposed in phase, the total intensity is proportional to

- A. the mean value of the intensities of the two waves.
 B. the square of the sum of the two amplitudes.
 C. the square of the mean value of the two amplitudes.

- D. the square of the difference of the two amplitudes.
- E. the sum of the intensities of the two waves.

20. In a simple astronomical telescope, under normal adjustment, which of the following statements is/are correct?

- (1) The first image is formed at the focal plane of the objective.
- (2) The first image is real and inverted.
- (3) The focal length of the objective is longer than that of the eyepiece.

- A. (1), (2) and (3)
- B. (1) and (2) only
- C. (2) and (3) only
- D. (1) only
- E. (3) only

21.

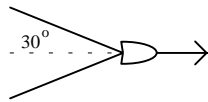

A boat travels in shallow water, in which waves of all wavelengths travel at a speed of 4.0 m/s. What is the speed of the boat if the bow wave generated by the boat has an apex angle of 30° ?

- A. 2.0 m/s
- B. 2.3 m/s
- C. 4.0 m/s
- D. 6.9 m/s
- E. 8.0 m/s

22.

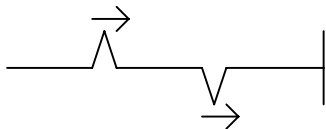

The figure shows two pulses travelling to the right along a rope. The right-hand end of the rope is fixed to a wall. The following figures represent predicted positions of the pulses at later times (where appropriate, the arrows indicate the direction of a pulse). Which of the following could NOT arise from the initial given condition?

(1)

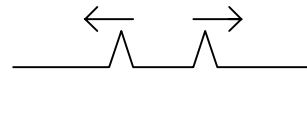

(2)

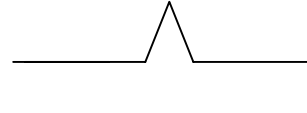

(3)

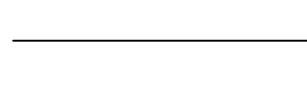

- A. (1), (2) and (3)
- B. (1) and (2) only
- C. (2) and (3) only
- D. (1) only
- E. (3) only

23.

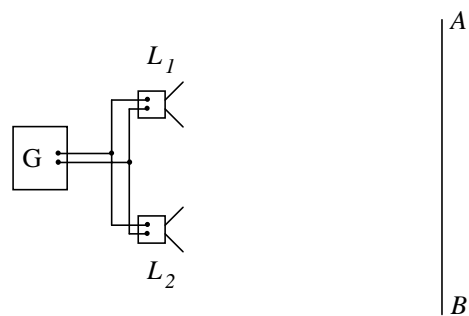

2 loudspeakers L_1 and L_2 are connected to a signal generator G . A microphone is moved along the line AB and the variation in intensity is noted. Which of the following statements concerning the above arrangement is/are correct?

- (1) If the separation of the 2 loudspeakers is less than the wavelength of the sound emitted, no alternation of maxima and minima can be detected along AB .
- (2) If the frequency of the sound waves emitted is increased, the separation between adjacent maxima along AB will be increased.
- (3) If the 2 loudspeakers are vibrating in antiphase, no alternation of maxima and minima will be detected along AB .

- A. (1), (2) and (3)
- B. (1) and (2) only

- C. (2) and (3) only
 D. (1) only
 E. (3) only
24. Sound waves of frequency f are emitted by a source S . When S is moved with speed u (relative to the ground) towards a stationary observer O , a rise in pitch of Δf is detected. Which of the following statements is/are correct?
- (1) The speed of sound waves relative to the observer is unaffected by the motion of S .
 - (2) If both S and O move in the same direction with speed u , no rise in pitch will be detected.
 - (3) If S is at rest with O moving towards it at speed u , the rise in pitch will also be Δf .
- A. (1), (2) and (3)
 B. (1) and (2) only
 C. (2) and (3) only
 D. (1) only
 E. (3) only
25. When parallel light is incident at the Brewster angle in air on the surface of a glass block, which of the following statements is/are correct?
- (1) The refracted light is plane-polarised.
 - (2) The reflected light is plane-polarised.
 - (3) The reflected ray and the refracted ray are at right angles to each other.
- A. (1), (2) and (3)
 B. (1) and (2) only
 C. (2) and (3) only
 D. (1) only
 E. (3) only
26. White light diffracted by a single slit falls on a white screen. Which of the following statements is/are correct?
- (1) The centre of the diffraction pattern is white.
 - (2) The first minimum is closer to the centre for red light than for blue light.
 - (3) The central band width is increased as the slit width is increased.
- A. (1), (2) and (3)

- B. (1) and (2) only
 C. (2) and (3) only
 D. (1) only
 E. (3) only

27.

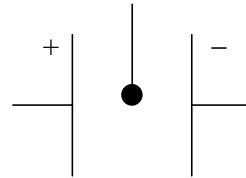

A light conducting sphere is hanged from a long insulating thread between oppositely charged metal plates connected to a high voltage supply. If the sphere is given a positive charge, it will

- A. move to the positive plate and stick to it.
 B. move to the negative plate and stick to it.
 C. remain still.
 D. oscillate, touching each plate in turn, beginning with the negative plate.
 E. oscillate, touching each plate in turn, beginning with the positive plate.

28.

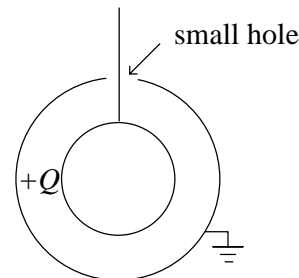

The arrangement above shows two concentric hollow metal spheres of inner radius b and outer radius a . A charge $+Q$ is given to the inner sphere and the outer sphere is earthed. What is the work done in bringing a small positive charge q from infinity to the surface of the inner sphere?

- A. zero
 B. $qQ/(4\pi\epsilon_0 a)$
 C. $qQ/(4\pi\epsilon_0 b)$
 D. $qQ/[4\pi\epsilon_0(a - b)]$
 E. $qQ(1/b - 1/a)/(4\pi\epsilon_0)$

29.

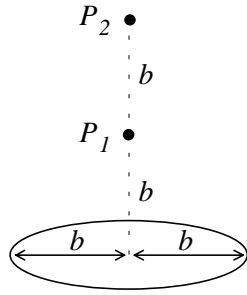

A uniformly charged wire has the form of a circular loop of radius b . P_1 and P_2 are two points on the axis of the loop. P_1 is at a distance b from the loop centre and P_2 is at a distance $2b$ from the loop centre. At P_1, P_2 , the potentials are V_1, V_2 respectively. V_2/V_1 is equal to

- A. $1/3$.
- B. $2/5$.
- C. $1/2$.
- D. $\sqrt{2}/\sqrt{5}$.
- E. 4π .

30.

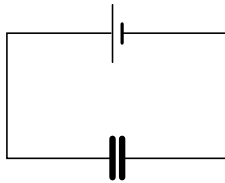

A parallel-plate capacitor is connected to a battery as shown. What will happen if the separation of the plates is increased?

| | | |
|--------------------|----------------|---------------|
| <u>capacitance</u> | <u>voltage</u> | <u>charge</u> |
|--------------------|----------------|---------------|

- | | | |
|--------------|-----------|-----------|
| A. decreases | decreases | decreases |
| B. decreases | unchanged | decreases |
| C. decreases | decreases | increases |
| D. increases | unchanged | decreases |
| E. increases | unchanged | increases |

31.

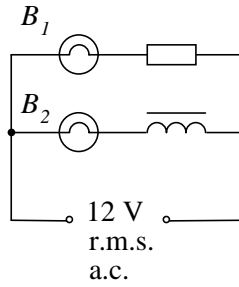

Bulbs B_1, B_2 are connected to an a.c. supply and both bulbs are lit. If the a.c. supply is replaced by a 12 V d.c. supply with negligible internal resistance, what will happen to the brightness of each bulb?

| | |
|-------|-------|
| B_1 | B_2 |
|-------|-------|

- | | |
|--------------|-----------|
| A. unchanged | increases |
| B. unchanged | decreases |
| C. decreases | increases |
| D. decreases | decreases |
| E. increases | unchanged |

32.

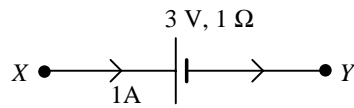

The figure above shows part of a circuit which carries a current of 1 A from X to Y through a cell of e.m.f. 3 V and internal resistance 1 Ω . The potential difference between X and Y is

- A. 0 V.
- B. 1 V.
- C. 2 V.
- D. 3 V.
- E. 4 V.

33.

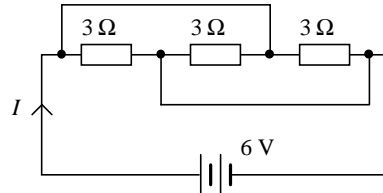

In the above circuit, the battery has negligible internal resistance. The current I is

- A. $2/3$ A.
- B. 1 A.

- C. $\frac{4}{3}$ A.
- D. 2 A.
- E. 6 A.

34. Which of the following circuits is best used for the measurement of a low resistance R ?

(Polarities of meter terminals are given in the diagram.)

A.

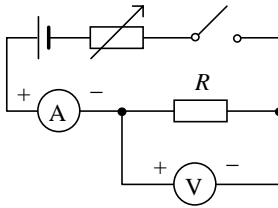

B.

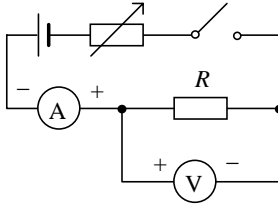

C.

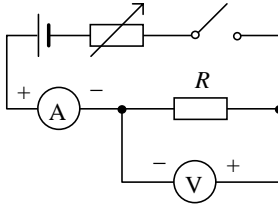

D.

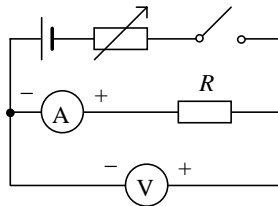

E.

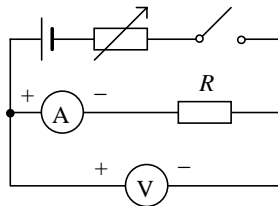

35.

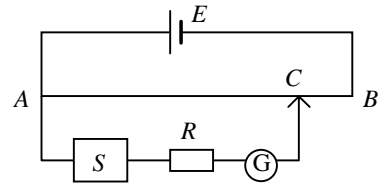

In the potentiometer circuit shown, S is a source whose e.m.f. is to be measured. R is a resistor to protect the galvanometer G . In the experiment, a student finds that G deflects in the same direction for any position of C , giving maximum deflection at B and minimum deflection (not zero) at A . Which of the following is the possible reason?

- A. S is connected with wrong polarity.
- B. The resistance of R is too high.
- C. There is contact resistance at A and B .
- D. The e.m.f. of the driver cell E is too low.
- E. The driver cell E has a large internal resistance.

36. A d.c. motor is connected to a 12 V battery. Which of the following statements is correct?

- (1) As the motor gathers speed, the current through the motor increases.
- (2) As the motor gathers speed, the torque acting on the rotating coil increases.
- (3) If the efficiency is 75% at steady state, the back e.m.f. is then 9 V.

- A. (1), (2) and (3)
- B. (1) and (2) only
- C. (2) and (3) only
- D. (1) only
- E. (3) only

37. A cell, a switch, a resistor and an inductor are connected in series to form a circuit. At time $t = 0$ the switch is closed. Which of the following best represents the variation of the current I in the circuit with time t ?

A.

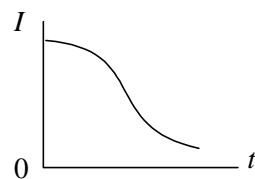

B.

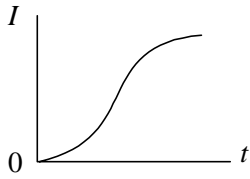

C.

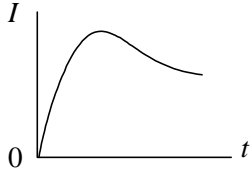

D.

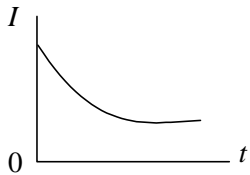

E.

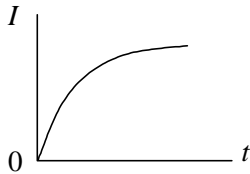

38. The self-inductance of an air-core solenoid can be increased by

- (1) increasing the current through it.
- (2) increasing the frequency of the supply.
- (3) placing a ferro-magnetic material inside the solenoid.

- A. (1), (2) and (3)
- B. (1) and (2) only
- C. (2) and (3) only
- D. (1) only
- E. (3) only

39.

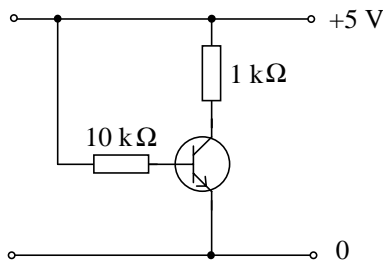

The circuit above shows an NPN transistor and two resistors $10\text{ k}\Omega$ and $1\text{ k}\Omega$ connected to a 5 V d.c. supply. The current gain of the transistor is 100. What is the value of the collector current?

- A. $5\text{ }\mu\text{A}$
- B. $500\text{ }\mu\text{A}$
- C. 5 mA
- D. 50 mA
- E. 500 mA

40. Electrical power is transmitted at high voltage over long distances because

- (1) a larger amount of energy can be transmitted per unit charge.
- (2) a smaller current is required for a fixed amount of power delivered.
- (3) less power is lost through heating during transmission.

- A. (1), (2) and (3)
- B. (1) and (2) only
- C. (2) and (3) only
- D. (1) only
- E. (3) only

41.

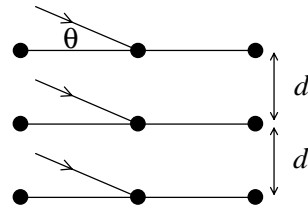

A beam of X-rays of wavelength λ is incident upon a crystal containing atoms arranged in planes of separation d . The beam makes an angle θ with the planes as shown, an intense diffracted X-ray beam is produced. Which of the following is equal to a small integer?

- A. $d \sin \theta / \lambda$
- B. $\lambda / (d \sin \theta)$
- C. $2 \lambda \sin \theta / d$
- D. $2 d \sin \theta / \lambda$
- E. $\lambda / (2 d \sin \theta)$

42.

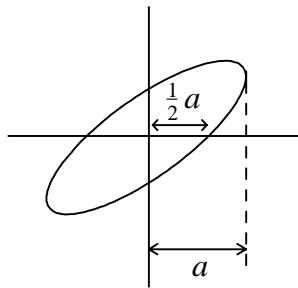

Two sinusoidal alternating potential differences V_x and V_y of the same frequency are applied respectively to the x and y plates of a C.R.O with the time base switched off. The trace on the screen is an ellipse as shown above. What is the phase difference between V_x and V_y ?

- A. 30°
- B. 45°
- C. 60°
- D. 120°
- E. 150°

43.

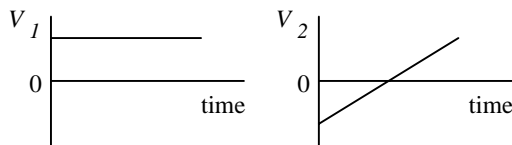

Potential difference V_1 and V_2 are applied to the X-plates and Y-plates of a C.R.O. respectively. The trace on the screen is

A.

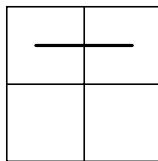

B.

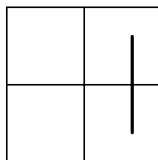

C.

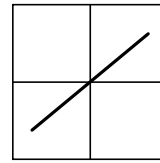

D.

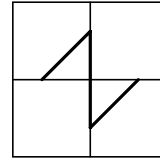

E.

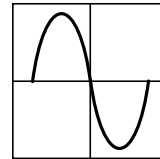

44. A high constant potential difference is applied across the electrodes of a discharge tube containing air. A vacuum pump gradually exhausts air from the tube. Which of the following will possibly happen?

- (1) Positive ions move towards the anode.
- (2) Some air molecules are ionised.
- (3) X-rays are emitted from the anode.

- A. (1), (2) and (3)
- B. (1) and (2) only
- C. (2) and (3) only
- D. (1) only
- E. (3) only

45.

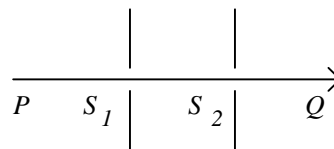

A mixed stream of ions (of different charges, polarities and speeds) travels along PQ and passes through a narrow slit S_1 . In the region between S_1 and S_2 , an electric field E and a magnetic field of flux density B are directed normally to each other. The E -field acts vertically downward and the B -field acts into the plane of the paper. Ions that are undeflected and emerge from slit S_2 must have the same

- A. polarity.
- B. speed.
- C. quantity of charge.
- D. mass.
- E. charge to mass ratio.

46.

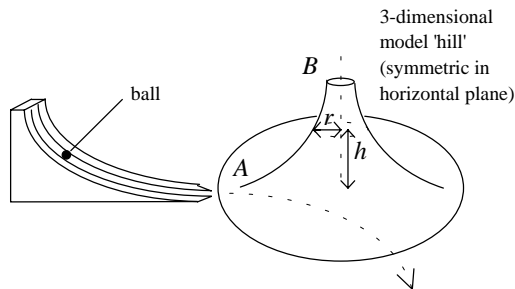

The figure shows the set-up for a gravitational analogue simulation of alpha-particle scattering by a thin metal sheet. What should be the relationship between the height of the 'hill' h and the radius of horizontal cross-sections r ?

- A. $hr = \text{constant}$
 - B. $hr^2 = \text{constant}$
 - C. $h^2r = \text{constant}$
 - D. $h^2r^3 = \text{constant}$
 - E. $h^3r^2 = \text{constant}$
47. The photoelectric effect occurs when monochromatic light falls upon a metal surface in a photocell. What happens when the light intensity increases?
- A. More electrons are emitted with unchanged speed.
 - B. More electrons are emitted with increased speed.
 - C. The same number of electrons is emitted with increased speed.
 - D. More photons are emitted from the surface.
 - E. Photons of greater energy are emitted from the surface.
48. A radioactive source is placed in front of a GM tube connected to a counter. Various absorbers are placed between the source and the GM tube and the count-rate recorded. The following results were obtained:

| Absorber | Counts per minute |
|-------------------------------|-------------------|
| no absorber | 711 |
| a sheet of paper | 508 |
| 5 mm thick of aluminium sheet | 493 |
| 25 mm of thick lead block | 218 |

It can be deduced from these results that the radiation(s) emitted by the source is/are

- A. α and γ rays only
- B. β and γ rays only
- C. α rays only
- D. β rays only
- E. γ rays only

49.

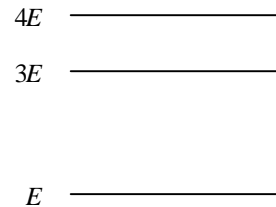

The diagram shows the energy levels of a certain atom. When an electron changes energy from $4E$ to E , a photon of wavelength λ is emitted. Which of the following wavelengths of photons could be produced by other transitions between the energy levels shown?

- A. $\lambda/3$ and $2\lambda/3$
 - B. $\lambda/3$ and 3λ
 - C. $2\lambda/3$ and $3\lambda/2$
 - D. $2\lambda/3$ and 3λ
 - E. $3\lambda/2$ and 3λ
50. In a collision between an electron and an atom which leads to excitation of the atom without ionization, which of the following is/are correct?
- (1) An orbital electron escapes from the nucleus.
 - (2) An orbital electron acquires energy.
 - (3) The energy transferred appears later as electromagnetic radiation.
- A. (1), (2) and (3)
 - B. (1) and (2) only
 - C. (2) and (3) only
 - D. (1) only

E. (3) only

- End of Paper -

| <u>Question No.</u> | <u>Key</u> | <u>Question No.</u> | <u>Key</u> |
|---------------------|------------|---------------------|------------|
| 1. | C | 26. | D |
| 2. | C | 27. | D |
| 3. | B | 28. | E |
| 4. | C | 29. | D |
| 5. | C | 30. | B |
| 6. | D | 31. | A |
| 7. | D | 32. | E |
| 8. | E | 33. | E |
| 9. | D | 34. | A |
| 10. | A | 35. | A |
| 11. | D | 36. | E |
| 12. | A | 37. | E |
| 13. | C | 38. | E |
| 14. | A | 39. | C |
| 15. | D | 40. | A |
| 16. | D | 41. | D |
| 17. | B | 42. | A |
| 18. | C | 43. | B |
| 19. | B | 44. | C |
| 20. | A | 45. | B |
| 21. | E | 46. | A |
| 22. | E | 47. | A |
| 23. | D | 48. | A |
| 24. | B | 49. | E |
| 25. | C | 50. | C |