



Applies To: **2002 Civic Si** – ALL
2003 Civic Si – From VIN SHHEP3...3U400001 thru SHHEP3...3U406119
2003 CR-V – From VIN SHSRD6...3U100001 thru SHSRD6...3U106587
 – From VIN SHSRD7...3U100001 thru SHSRD7...3U141932

November 7, 2003

Knocking From the Front Suspension

(Supersedes 03-075, dated October 14, 2003)

SYMPTOM

Knocking comes from the front suspension while driving over a bumpy road.

PROBABLE CAUSE

The damper shaft nut isn't tight enough.

CORRECTIVE ACTION

Loosen and retorque the damper shaft nut to the appropriate torque specification.

WARRANTY CLAIM INFORMATION

In warranty: The normal warranty applies.

OP#	Description	FRT
414022	Torque damper shaft left side and/or right side, includes test-drive	0.4

Failed Part: P/N 51601-S5T-A03 (Civic Si)
H/C 7051360

P/N 51601-S9A-A06 (CR-V)
H/C 6918254

Defect Code: 07405

Symptom Code: 04208

Skill Level: Repair Technician

Out of warranty: Any repair performed after warranty expiration may be eligible for goodwill consideration by the District Parts and Service Manager or your Zone Office. You must request consideration, and get a decision, before starting work.

DIAGNOSIS

Test-drive the vehicle over a rough road while turning left or right. Note any noise and the side(s) it comes from.

REPAIR PROCEDURE

1. Hold the damper shaft with a 6 mm hex (Allen) wrench, and loosen the damper nut 1/2 turn with a 17 mm crowfoot and ratchet.

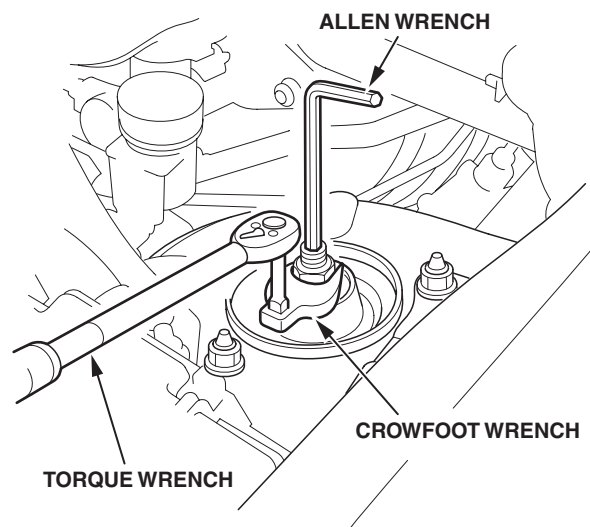

2. Hold the damper shaft with a 6 mm hex (Allen) wrench, and use a torque wrench with a 17 mm crowfoot to torque the damper shaft nut to 49 N·m (36 lb-ft).
3. Repeat steps 1 and 2 for the other side, if necessary.
4. Test-drive the vehicle to confirm that the noise is gone.



CUSTOMER INFORMATION: The information in this bulletin is intended for use only by skilled technicians who have the proper tools, equipment, and training to correctly and safely maintain your vehicle. These procedures should not be attempted by "do-it-yourselfers," and you should not assume this bulletin applies to your vehicle, or that your vehicle has the condition described. To determine whether this information applies, contact an authorized Honda automobile dealer.