



Applies To: **2002 CR-V – ALL**

2003 CR-V 2WD – From VIN SHSRD6...3U100001 thru SHSRD6...3U100519

2003 CR-V 4WD – From VIN SHSRD7...3U100001 thru SHSRD7...3U102609

2002 Civic Si – From VIN SHHEP3...2U300001 thru SHHEP3...2U305595

September 30, 2003

Front Door Glass Comes Out of the Run Channel

(Supersedes 03-025, dated April 1, 2003)

SYMPTOM

The rear edge of the front door glass comes out of the run channel.

PROBABLE CAUSE

The door glass and the run channel are not aligned.

CORRECTIVE ACTION

Align the door glass with the run channel.

WARRANTY CLAIM INFORMATION

In warranty: The normal warranty applies.

Operation Number: 826300 (driver's side)
827300 (passenger's side)

Flat Rate Time: 1.0 hour (per side)

Failed Part: P/N 73300-SCA-A00
H/C 7106222

Defect Code: 074

Contention Code: A02

Skill Level: Repair Technician

Out of warranty: Any repair performed after warranty expiration may be eligible for goodwill consideration by the District Parts and Service Manager or your Zone Office. You must request consideration, and get a decision, before starting work.

REPAIR PROCEDURE

1. Remove the door panel and trim (see page 20-7 in the 2002–04 CR-V Service Manual, or page 20-4 in the 2002–03 Civic Si Service Manual).
2. Use a utility knife to cut the adhesive, then pull back the plastic cover (see page 20-3 in the 2002–04 CR-V Service Manual, or page 20-2 in the 2002–03 Civic Si Service Manual).
3. Connect the power window switch, and move the window until you can access the glass mounting bolts. Loosen the bolts.

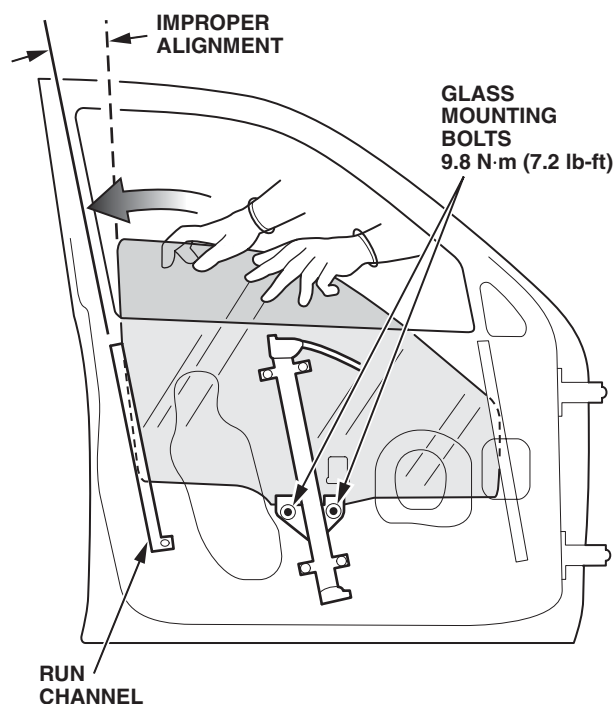

4. Move the door glass so the back edge is parallel with the run channel. Tighten the glass mounting bolts to 9.8 N·m (7.2 lb-ft).
5. Move the door glass up and down, making sure it operates smoothly and contacts the run channel evenly.
6. Reinstall all removed parts.