

## HYBRID INTEGRATED CIRCUIT VHF/UHF WIDE-BAND AMPLIFIER

One-stage wide-band amplifier in hybrid integrated circuit technique on a thin-film substrate, intended for aerial amplifiers in car radios, caravans or RATV and MATV applications.

## QUICK REFERENCE DATA

D.C. supply voltage	$V_B$	*	12 V $\pm$ 10%
Frequency range	f		40 to 860 MHz
Source and load (characteristic) impedance	$R_s = R_L = Z_0$	*	75 $\Omega$
Transducer gain	$G_{tr} =  s_f ^2$	typ.	12 dB
Flatness of frequency response	$\pm \Delta  s_f ^2$	typ.	1 dB
Output voltage at -60 dB intermodulation distortion (DIN 45004, 3-tone)	$V_{O(rms)}$	typ.	99 dB $\mu$ V
Noise figure	F	typ.	5,5 dB
Operating ambient temperature	$T_{amb}$		-20 to +70 $^{\circ}$ C

ENCAPSULATION 5-pin, in-line, resin-coated body, see MECHANICAL DATA (Fig. 2)

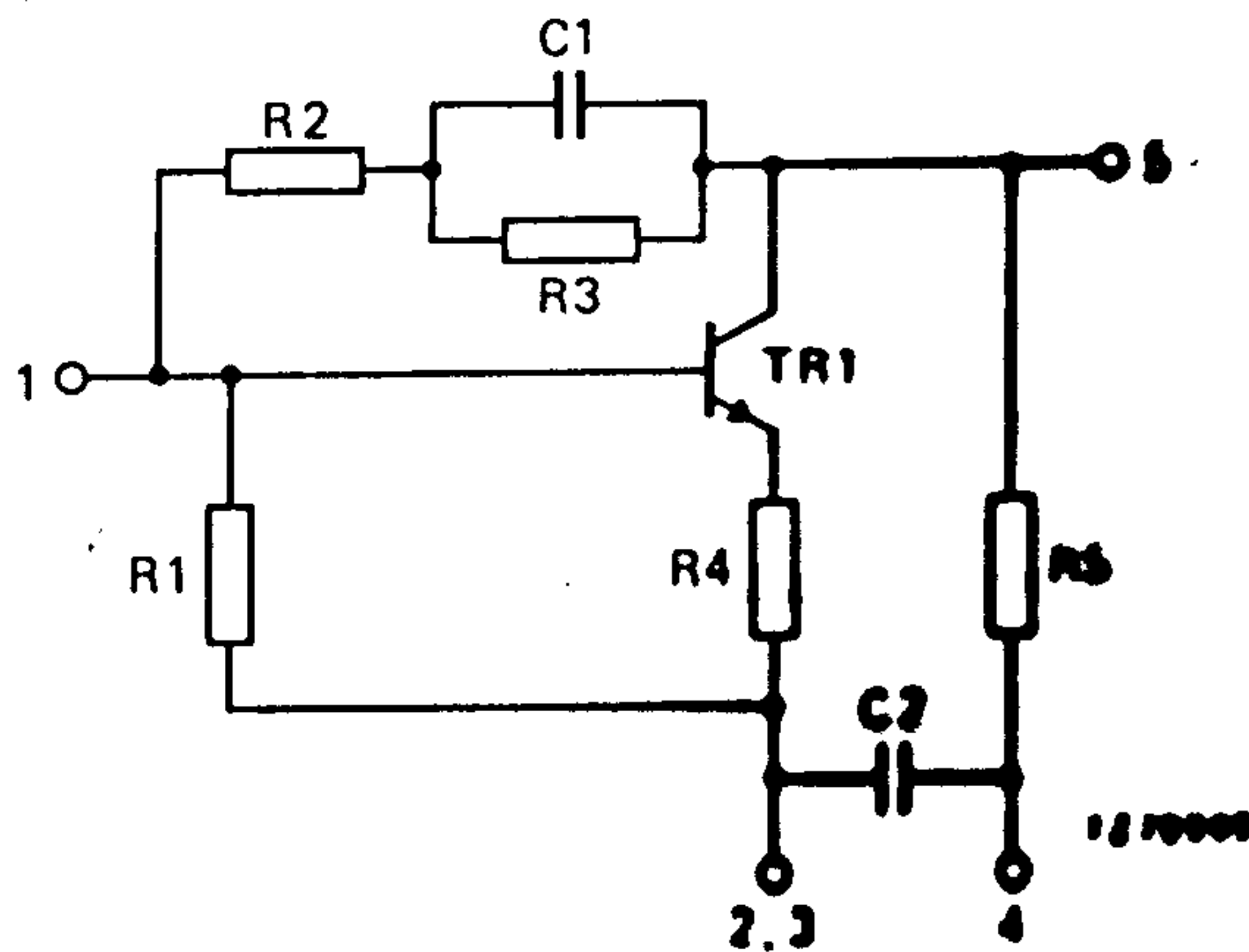

Fig. 1 Circuit diagram

**RATINGS**

Limiting values in accordance with the Absolute Maximum System (IEC 134)

Operating ambient temperature	$T_{amb}$	-20 to +70 °C
Storage temperature	$T_{stg}$	-40 to +125 °C
D.C. supply voltage	$V_B$	max. 15 V
Peak incident powers on pins 1 and 5	$P_{I1M}, P_{I5M}$	max. 100 mW

**CHARACTERISTICS**

**Measuring conditions**

Ambient temperature	$T_{amb}$	=	25 °C
D.C. supply voltage	$V_B$	=	12 V
Source impedance and load impedance	$R_s, R_l$	=	75 $\Omega$
Characteristic impedance of h.f. connections	$Z_0$	=	75 $\Omega$
Frequency range	$f$	=	40 to 860 MHz

**Performance**

Supply current	$I_B$	typ.	11,5 mA
Transducer gain	$G_{tr} =  s_f ^2$	typ.	12 dB
Flatness of frequency response	$\pm \Delta  s_f ^2$	typ.	1 dB
Individual maximum v.s.w.r.			
input	$VSWR_{(i)}$	typ.	2,0 *
output	$VSWR_{(o)}$	typ.	1,4 *
Back attenuation			
f = 100 MHz	$ s_r ^2$	typ.	22 dB
f = 860 MHz	$ s_r ^2$	typ.	19 dB
Output voltage			
at -60 dB intermodulation distortion			
(DIN 45004, par. 6.3: 3-tone)	$V_{O(rms)}$	typ.	99 dB $\mu$ V
Noise figure	F	typ.	5,5 dB

s-parameters:	$s_f = s_{21}$	$s_i = s_{11}$
	$s_r = s_{12}$	$s_o = s_{22}$

\* Highest value, for a sample, occurring in the frequency range.

## OPERATING CONDITIONS

Ambient temperature range  
 D.C. supply voltage  
 Frequency range  
 Source impedance and load impedance

$T_{amb}$  = -20 to +70 °C  
 $V_B$  = 12 V  $\pm$ 10%  
 $f$  = 40 to 860 MHz  
 $R_s, R_l$  = 75  $\Omega$

## MECHANICAL DATA

The device is resin coated.

Dimensions in mm

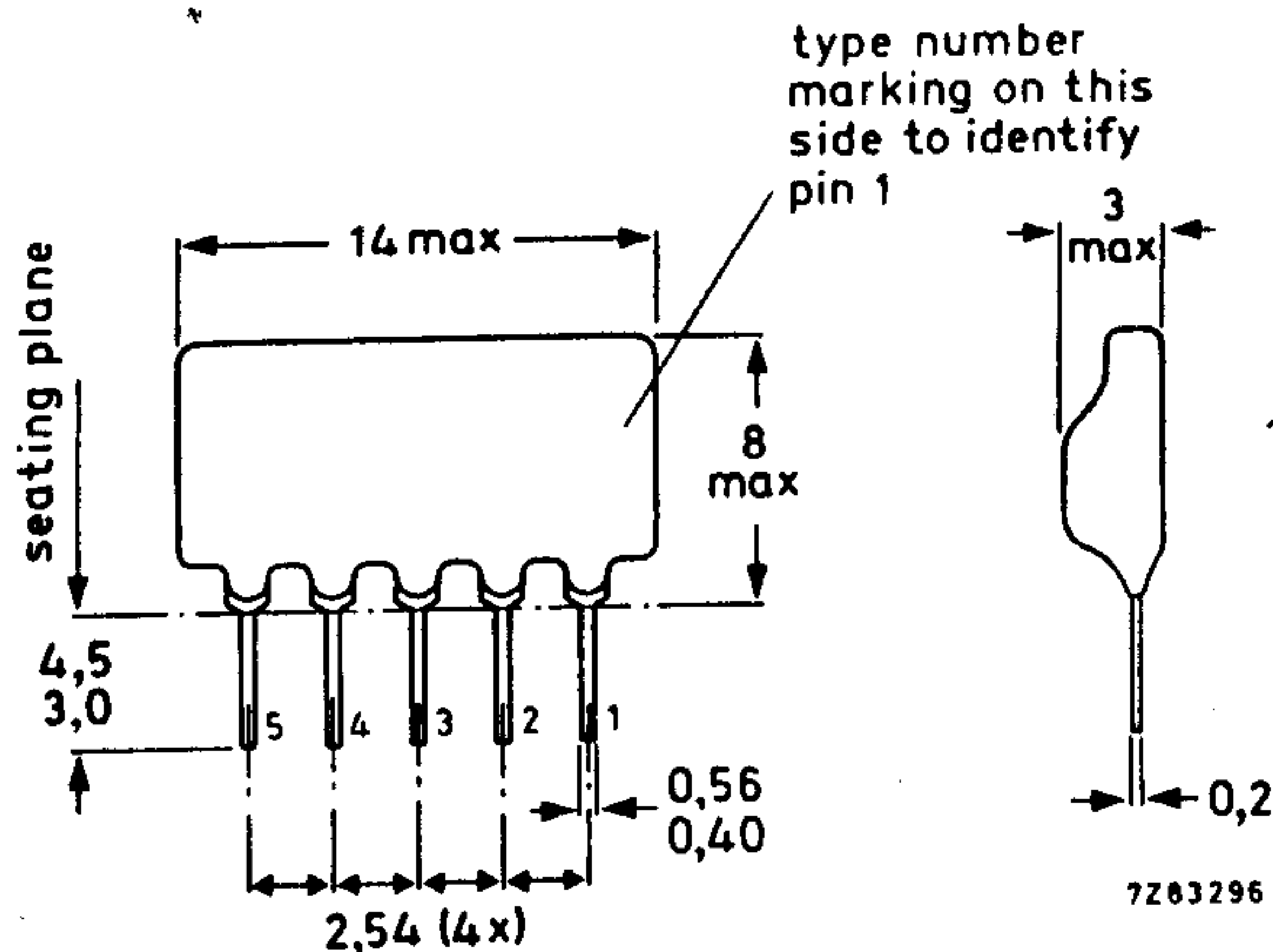

Fig. 2 Encapsulation.

## Terminal connections

1 = input  
 2,3 = common  
 4 = supply (+)  
 5 = output

## Soldering recommendations

*Hand soldering*

Maximum contact time for a soldering-iron temperature of 260 °C up to the seating plane is 5 s.

*Dip or wave soldering*

260 °C is the maximum permissible temperature of the solder; it must not be in contact with the joint for more than 5 seconds. The total contact time of successive solder waves must not exceed 5 seconds. The device may be mounted against the printed-circuit board, but the temperature of the device must not exceed 125 °C. If the printed-circuit board has been pre-heated, forced cooling may be necessary immediately after soldering to keep the temperature below the allowable limit.

**Mounting recommendations**

The module should preferably be mounted on double-sided printed-circuit board, see the example shown below.

Input and output should be connected to 75  $\Omega$  tracks.

The connections to the 'common' pins should be as close to the seating plane as possible.

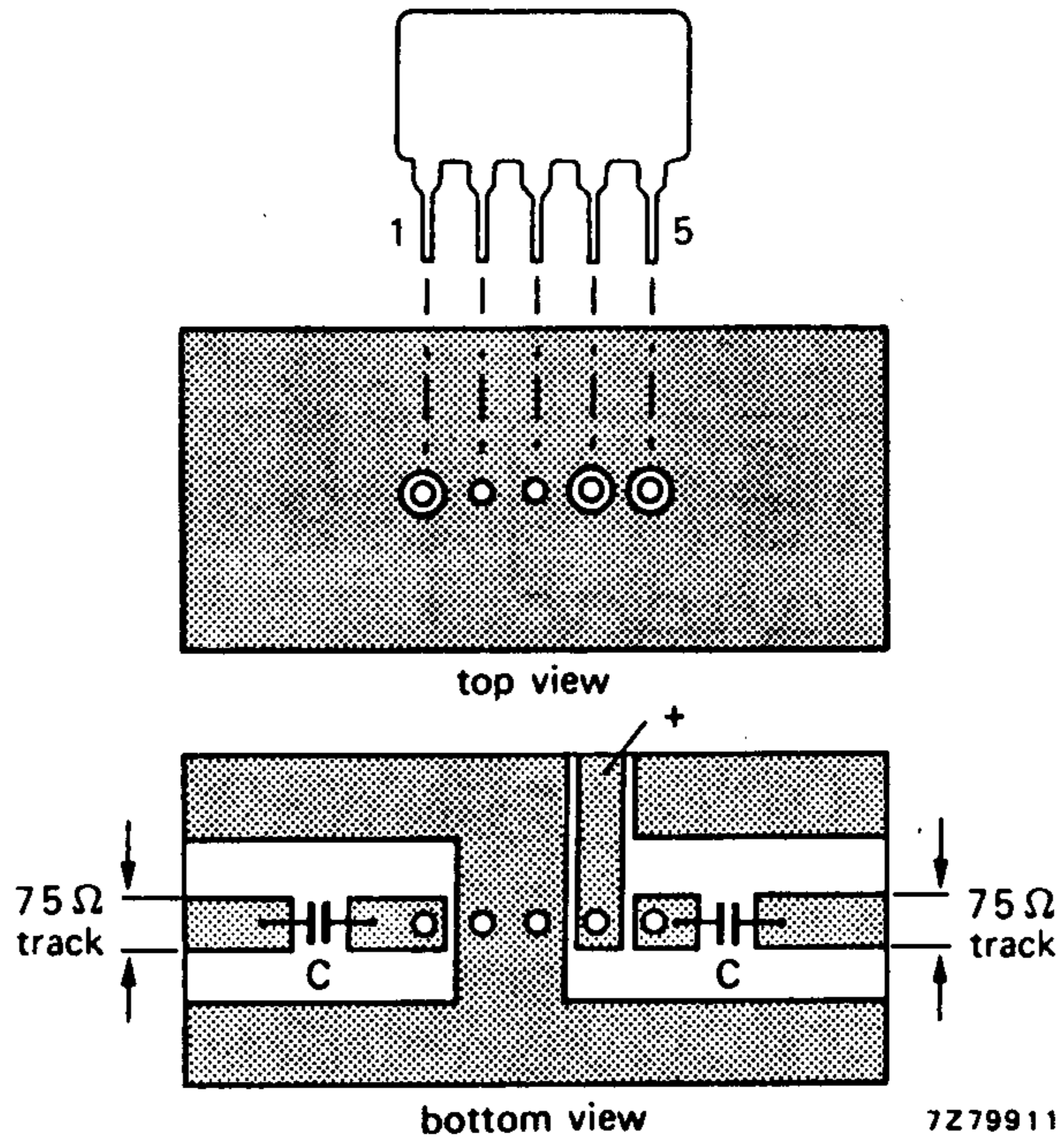

Fig. 3 Printed-circuit board holes and tracks.  
 $C > 220$  pF ceramic capacitor.

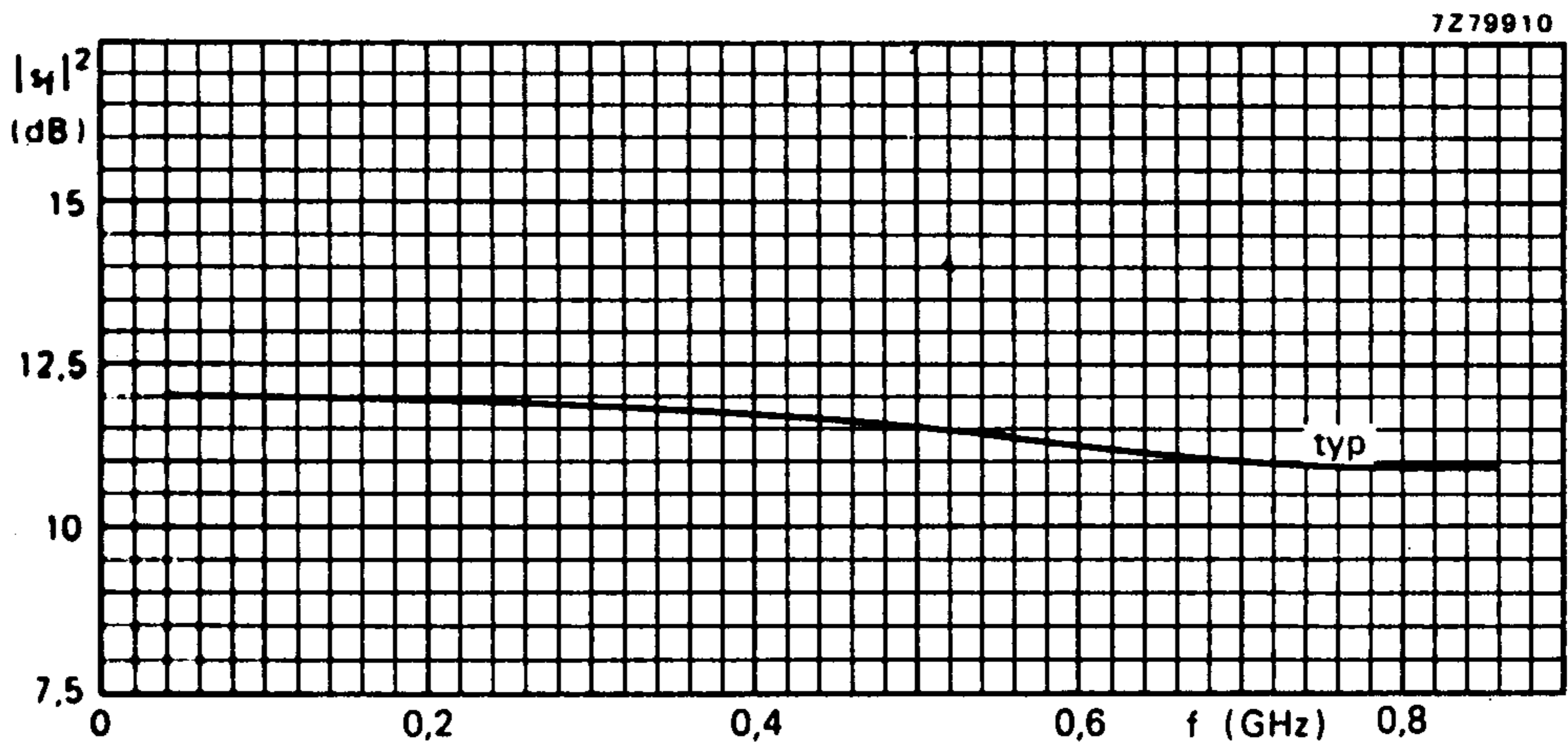

Fig. 4 Transducer gain as a function of frequency;  $Z_C = 75 \Omega$ .

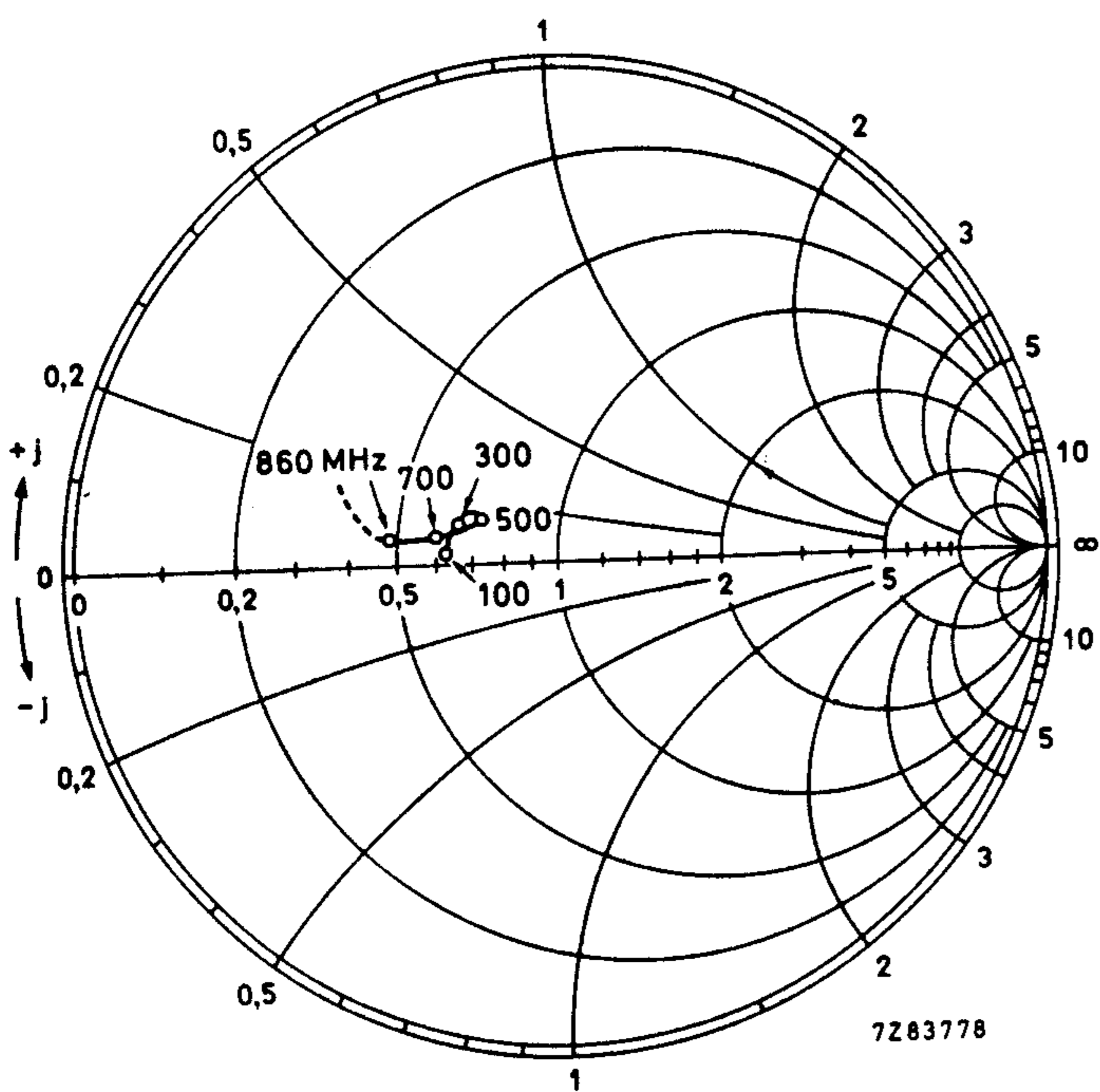

Fig. 5 Input impedance derived from input reflection coefficient  $s_i$ , co-ordinates in ohm x 75; typical values.

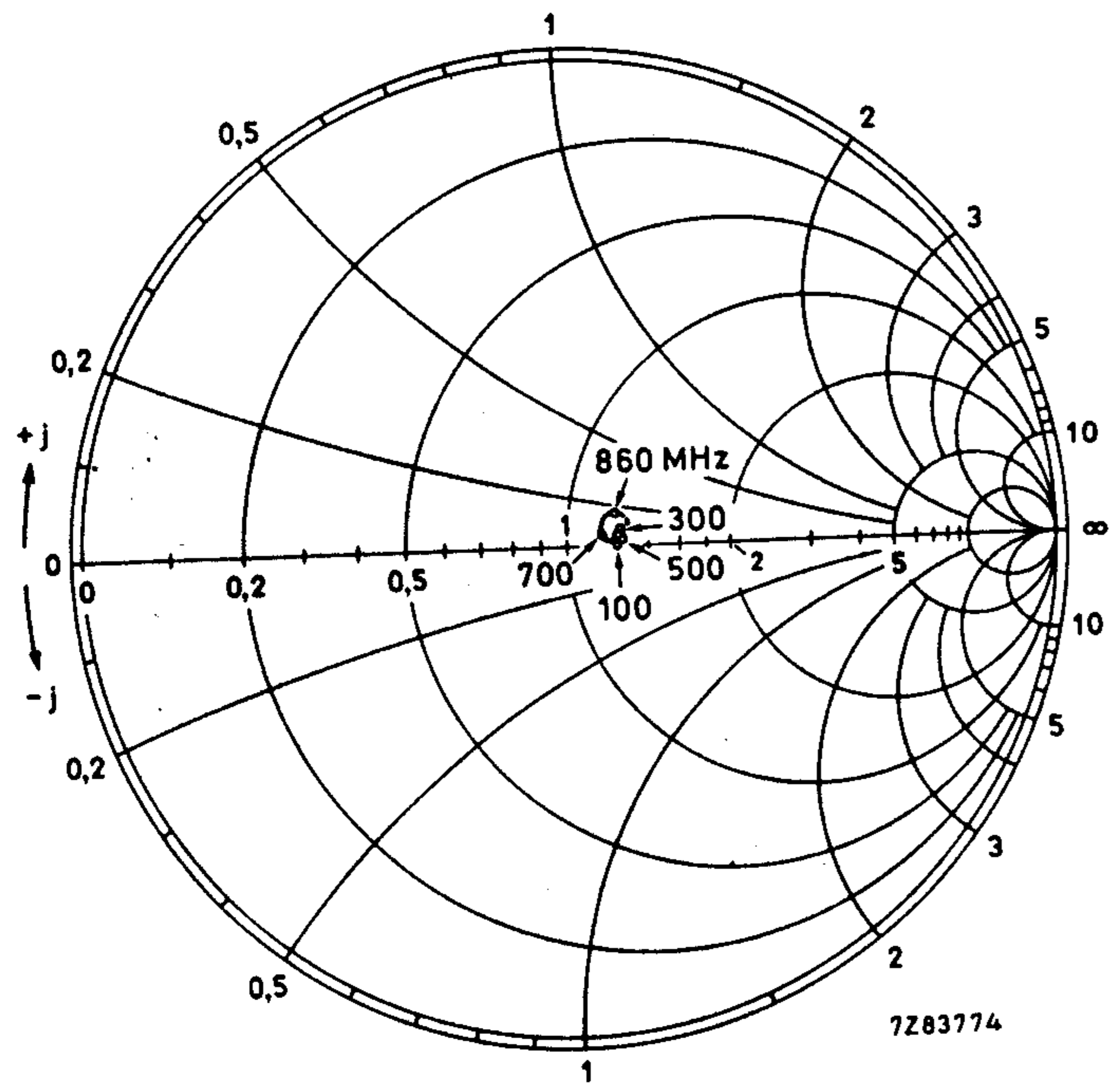

Fig. 6 Output impedance derived from output reflection coefficient  $s_o$ , co-ordinates in ohm x 75; typical values.

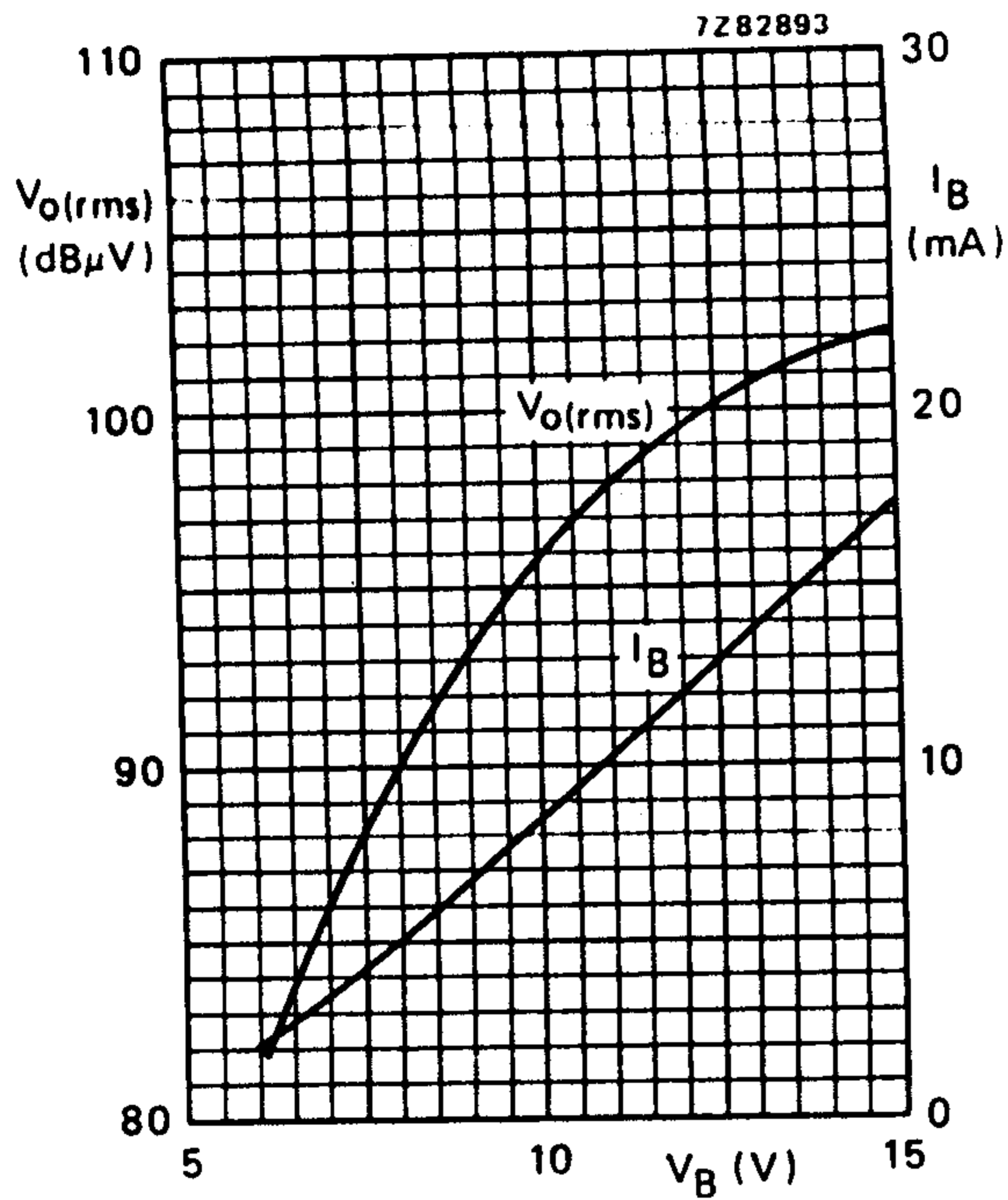

Fig. 7 Output voltage and supply current as a function of the supply voltage; typical values.

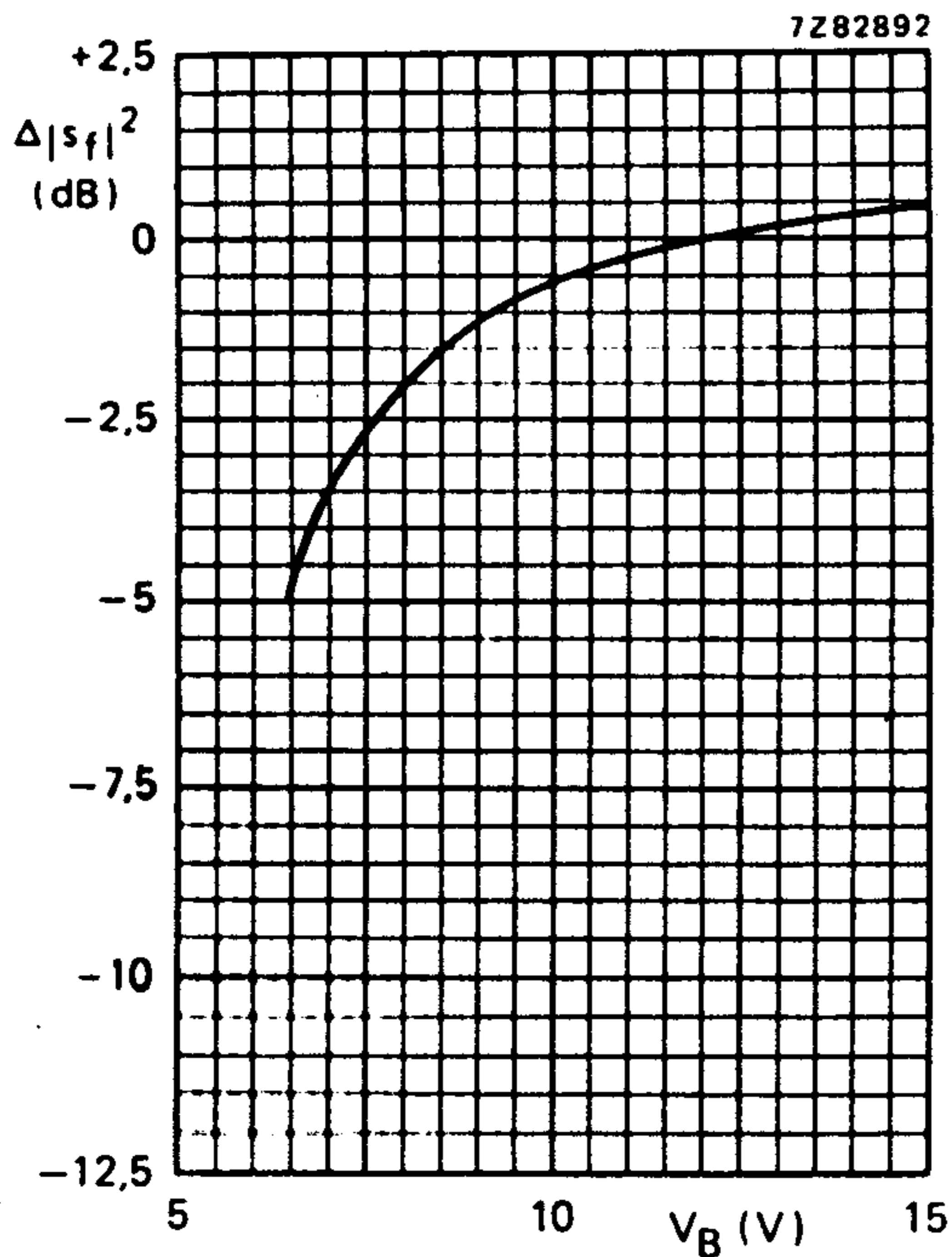

Fig. 8 Variation of transducer gain with supply voltage; reference 0 dB at 12 V;  $f = 100$  to 860 MHz; typical values.