

1. HEATER

1.1 GENERAL

Incorrect setting of the heater voltage and, in consequence, a cathode temperature too high or too low, may lead to unsatisfactory operation and cause the valve life to be shortened.

1.2 SURGE CURRENT

With some valves it may be required to limit the heater current when switching on the heater supply. Individual data sheets give information on this together with the cold heater resistance to assist in the design of a suitable surge current limiting circuit.

1.3 STARTING VOLTAGE

With indirectly heated cathodes the heater starting voltage should be set within  $\pm 2.5\%$  at nominal supply input voltage.

In the case of directly heated cathodes reference should be made to the individual data sheets.

1.4 PRE-HEATING TIME

Before the application of the h. t. supply the heater starting voltage should be applied for a time not less than that stated in the individual data sheets. This ensures adequate electron density to start oscillation in the required mode.

1.5 RUNNING VOLTAGE

During operation the cathode temperature is increased by electron back bombardment ("back heating"). The individual data sheets, therefore, contain information relating the heater running voltage to the average anode current so that the cathode temperature can be maintained at the desired level. The heater voltage must be reduced to the appropriate value immediately the h. t. voltage is applied.

1.6 TEMPORARY FLUCTUATIONS

Unless otherwise stated in the individual data sheets, the cathode will accept temporary fluctuations of heater voltage within the range  $+5\%$  to  $-10\%$  of the nominal values

---

## 2. INPUT AND OUTPUT CONNECTIONS

### 2.1 INPUT CONNECTION

To prevent anode current flowing through the heater the negative h.t. voltage line should be connected to the common heater-cathode terminal.

### 2.2 OUTPUT CONNECTION

It is important that the type of output connection should be as specified in the data. Connections to the output must be designed to prevent misaligned surfaces which introduce reflecting discontinuities and must be sufficiently tight to avoid arcing. It is also important to avoid undue stressing of the output section which would either deform the metal or break the glass or ceramic vacuum seals. It is necessary therefore that any mechanical pressure be applied uniformly, when a uniform mechanical pressure is not certain a flexible mounting must be provided, e.g. rubber bushes for fixing screws.

## 3. H. T. SUPPLY

### 3.1 GENERAL

Usually the dynamic impedance of a magnetron is low, therefore small variations in the applied voltage can cause appreciable changes in operating current. In the equipment design it is necessary to ensure that such resultant variations in operating current do not lead to operation outside the published limits.

Changes in current cause changes in power and frequency and, consequently, change the equipment performance. Their effects should determine the maximum permissible change of current inherent in the equipment design under the worst operating conditions. Where these changes in performance are not acceptable, either manual control or automatic stabilisation of the average operating current must be incorporated in the power supply design.

### 3.2 MINIMUM OPERATING CURRENT

At a low operating current, above the threshold of oscillation, magnetrons can develop a negative resistance characteristic. When operated with an unregulated power supply, additional



---

series resistance is necessary to prevent instability. With a regulated power supply the range of control should be limited to avoid hunting. For this reason a minimum operating current is given in the data sheets.

### 3.3 PEAK CURRENT LIMITATION

In certain applications an unfiltered power supply is used. In these circumstances care should be taken to ensure that the peak current rating cannot be exceeded. A resistance or inductance is usually needed in series with the power supply to augment the inherent regulation of the supply.

## 4. LOADING

### 4.1 GENERATOR LOAD CHART (RIEKE DIAGRAM)

A chart showing typical output power and frequency change plotted on a modified impedance circle diagram against magnitude (v. s. w. r.) and phase of the load seen by the magnetron provides information on the behaviour of the magnetron under various load conditions.

Such a chart is often referred to as a Rieke diagram.

With a load of bad mismatch and at a particular phase there is a region on the chart which is characterised by high power output and convergence of the frequency contours. This region is known as the "sink" and the phase of the load at which the magnetron behaves in this manner is known as "the phase of sink". Operation of the magnetron under this load condition will lead to instability and may cause failure.

The region opposite the sink indicates a low power output. A low power output leads to excessive anode dissipation and increased "back heating" of the cathode. These effects can be detrimental to the life of the magnetron and should be avoided.

### 4.2 MAXIMUM VOLTAGE STANDING WAVE RATIO OF LOAD

Information on the maximum standing wave ratio that can be withstood under continuous operation is given in individual data sheets. Incorrect loading (exceeding this value of v. s. w. r.) may cause unstable operation in the form of moding or arcing.

---

#### 4.3 COLD LOAD MEASUREMENT

Before the h.t. is applied it must be established that the load condition is such that the v.s.w.r. presented to the magnetron at its output connection does not exceed the limiting value. For this purpose low power measurements using a standing wave detector or reflectometer technique are necessary over an appropriate frequency range about the actual magnetron frequency. The frequency range must be adequate to cover operational frequency drift due to, current pushing, load pulling and magnetron temperature change.

When magnetrons are likely to be replaced in equipment without further measurement or adjustment of the coupling system, the low power measurements must cover a frequency range which embraces the whole frequency band of the magnetron together with an extension to cover operational frequency drift outside the band.

It should be noted that the value of v.s.w.r. will be vastly different when the load is removed from the applicator or heating chamber and that h.t. should never be applied under this condition. As a protection against this risk a suitable preload should be incorporated in the microwave circuit.

#### 4.4 ON-LOAD MEASUREMENTS

It is possible to monitor the power reflected from the load to the magnetron by means of a reflectometer technique. If it is possible for the reflected power to become excessive so that the v.s.w.r. limit is approached, the magnetron should be safeguarded by means of an automatic h.t. switch-off.

#### 4.5 INSTANTANEOUS LOAD CONDITION

Some equipments include a device which provides a varying field pattern, to produce a more uniform energy distribution. This device introduces a varying instantaneous load condition. Some relaxation of the maximum v.s.w.r. rating under continuous operation can be allowed for instantaneous load conditions outside the "sink" region provided that the average reflected power does not exceed that implied by the continuous v.s.w.r. rating. Any relaxation should be agreed with Mullard Limited. No relaxation can be permitted in the sink region.

## 5. COOLING

### 5.1 GENERAL

The cooling requirements given in the data sheets refer to magnetrons operated under open bench conditions. In order to keep within the limiting temperatures for anode block, cathode terminal assembly and output seal, where appropriate, it may be necessary in the practical equipment to provide additional coolant on account of high environmental temperatures due to restrictions imposed by the cabinet and to associated components within the cabinet, and to high ambient temperatures at the equipment location.

The residual heat of the cathode on switch-off may raise the seal temperature above its permitted maximum. This danger can be avoided either by continuing the airflow after removal of cathode heater power or by using sufficient air during operation to keep the temperature of the cathode so low that the rise in seal temperature on switch-off can be accommodated.

Having regard to the limiting temperatures, measurements should be made in the development stage of an equipment using special paints, lacquers, thermopapers or other suitable means.

Thermal cut out switches should be used to prevent operation with excessive anode block temperature in the event of reduction or failure of the cooling medium.

### 5.2 AIR COOLING

It is important that the air should not contain dust, moisture or oil. If an air filter is incorporated in the system, allowance must be made for the pressure drop across the filter when choosing an adequate blower.

### 5.3 WATER COOLING

Circulating cooling water should be as free as possible from all solid matter and its dissolved oxygen content should be low. A closed water system using demineralised or distilled water should be used whenever possible.

## 6. INSTALLATION

The magnetron should never be held by the cathode radiator.

Because the magnet produces a strong field, only non-magnetic tools may be used for installing the magnetron or adjacent components, this reduces the risk of collision between the tools and the glass parts of the magnetron.

## 7. MOUNTING

The minimum distance from other magnetic materials given on the data sheet must be maintained to prevent deterioration of the magnetron performance. Other devices which produce stray magnetic fields (Blower or stirrer motor) should be placed so that they do not influence the operation of the magnetron.

The magnetron should be mounted by means of the mounting holes provided. It should NEVER be supported by the coupling to the magnetron output system.

## 8. STORAGE

Magnetrons should be stored in their original packing because this has been designed to protect them against reasonable vibration and knocks. It also ensures that the spacing between permanent magnet valves and other magnets and ferrous objects is adequate to avoid demagnetisation.

Magnetically sensitive instruments such as compasses, electric meters and watches should not be brought close to a bank of packaged magnetrons.

When a magnetron is temporarily taken out of service it should be placed immediately in its proper container. This is good practice and obviates the risk of damage to the magnets or the glass and ceramic parts and prevents the entry of foreign matter into the output aperture.

Unpacked permanent magnet valves should NEVER be placed on steel benches or shelves.



9.      CONDITIONING

After transit or a long period of storage, the h.t. voltage should be increased gradually or in several steps until normal operation is achieved. This treatment will remove any traces of gases which could cause instability, it is particularly important in high power magnetrons.

10.     STRAY MICROWAVE RADIATION

The document\* entitled "Safety Precautions Relating To Intense Radio-Frequency Radiation" implies that a stray radiation field is a human hazard if the power density exceeds  $10\text{mW}/\text{cm}^2$ . The power output of industrial magnetrons is such that, with improperly sealed or defective closures and connections in the transmission system, this power density can easily be exceeded. Serious attention should be given to this point in the manufacture of equipment with due regard to probable deterioration through its life.

\* Published by H. M. S. O. 1960 S. O. Code No. 43-182.

## QUICK REFERENCE DATA

Magnetron for use in microwave diathermy or as a laboratory source for gas ionisation.

Frequency	2.45	GHz
Power output (c.w.)	200	W
Construction		Packaged

To be read in conjunction with

## GENERAL OPERATIONAL RECOMMENDATIONS - MICROWAVE DEVICES

CHARACTERISTICS (measured at  $I_a = 200\text{mA d.c.}$ , v.s.w.r. < 1.05)

Frequency fixed within the band	2.425 to 2.475	GHz
Operating voltage range (d.c.)	1.55 to 1.7	kV

## OPERATION FROM SINGLE-PHASE SUPPLY WITHOUT RECTIFIER

OPERATING CONDITIONS (using h.t. supply with  $Z > 250\Omega$ )

*Heater voltage (running)	4.5	V
Mean anode current	200	mA
Peak anode current	1.3	A
Load mismatch (v.s.w.r.)	1.5	
Power output (matched load)	200	W

\*For different values of anode current, the heater voltage should be adjusted in accordance with either curve 'a' or 'b' on page C3.

## RATINGS (ABSOLUTE MAXIMUM SYSTEM)

	Min.	Max.	
Heater voltage (starting)	4.8	5.6	V
Heater surge current	-	8.5	A
Mean anode current	-	230	mA
Peak anode current	-	1.4	A
Load mismatch (v.s.w.r.)	-	2.0	
Envelope temperature	-	125	°C

OPERATION FROM SINGLE - PHASE FULL-WAVE RECTIFIER WITHOUT SMOOTHING FILTER

OPERATING CONDITIONS (using h.t. supply with  $Z > 500\Omega$ )

*Heater voltage (running)	4.6	V
Mean anode current	200	mA
Peak anode current	700	mA
Load mismatch (v.s.w.r.)	1.5	
Power output (matched load)	200	W

\*For different values of anode current, the heater voltage should be adjusted in accordance with either curve 'a' or 'b' on page C3.

RATINGS (ABSOLUTE MAXIMUM SYSTEM)

	Min.	Max.	
Heater voltage (starting)	4.8	5.6	V
Heater surge current	-	8.5	A
Mean anode current	-	230	mA
Peak anode current	-	800	mA
Load mismatch (v.s.w.r.)	-	2.0	
Envelope temperature	-	125	°C

## OPERATION FROM D.C. SUPPLY

To obtain optimum power output, it is necessary to insert between the magnetron and the load, a fixed reflection element (see page D8) giving a mismatch with v.s.w.r. of 2.0 in "phase of sink".

## OPERATING CONDITIONS

*Heater voltage (running)	4.0	4.8	V
Mean anode current	150	100	mA
Peak anode current	220	150	mA
†Load mismatch (v.s.w.r.)	2.0	2.0	
†Power output (matched load)	150	100	W

\*For different values of anode current, the heater voltage should be adjusted in accordance with curve 'c' on page C3.

## RATINGS (ABSOLUTE MAXIMUM SYSTEM)

	Min.	Max.	
Heater voltage (starting)	4.4	5.0	V
Heater surge current	-	8.5	A
Mean anode current	-	200	mA
Peak anode current	-	400	mA
†Load mismatch (v.s.w.r.)	-	3.0	
Envelope temperature	-	125	°C

†Excluding fixed reflection element

## CATHODE

Indirectly heated

Anode supply	A.C. or rectified A.C.	D.C.	
** $V_h$ (starting)	5.3	4.8	V
$I_h$	3.5	3.3	A
$r_h$ (cold)	0.2	0.2	$\Omega$
Preheat delay before applying h.t.	3.0	4.0	min.

\*\*Temporary fluctuations not exceeding +5% and -10% of the nominal heater voltage are permissible.

The heater voltage must be reduced immediately after the application of h.t. in accordance with the curves on page C3.

## OUTLINE DRAWING

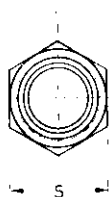
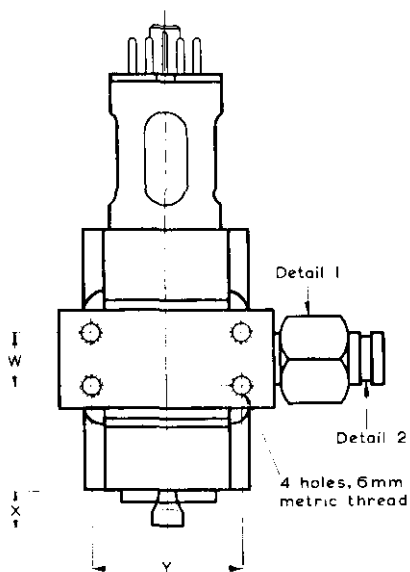

Detail 1

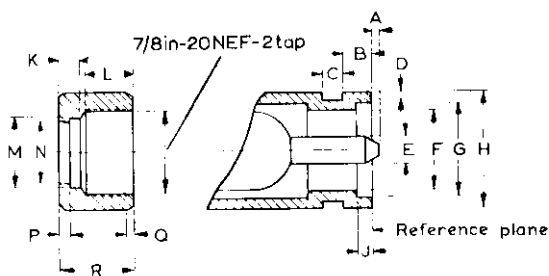

Detail 2

Note:

The inner conductor (E above) will always lie within a circle of diameter 5.5mm.

# DIMENSIONS

	Millimetres	Inches
T	90	3.54
U	30	1.18
V	80	3.15
Z	50	1.97
AA	71	2.80
BB	64	2.52
CC	33	1.30
DD	64	2.52

Inch dimensions derived from original millimetre dimensions.



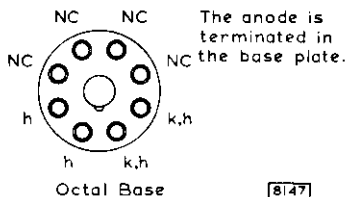
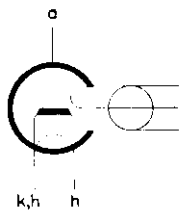
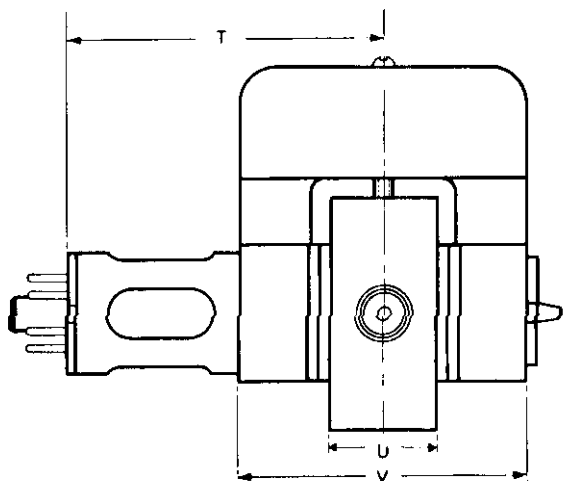
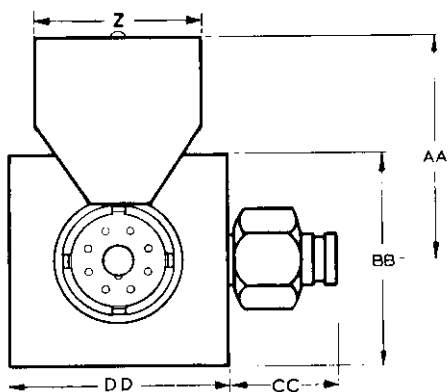

8147

FIXED REFLECTION ELEMENT  
 TEFLON  $\epsilon_r = 2.0$  DRIVING FIT

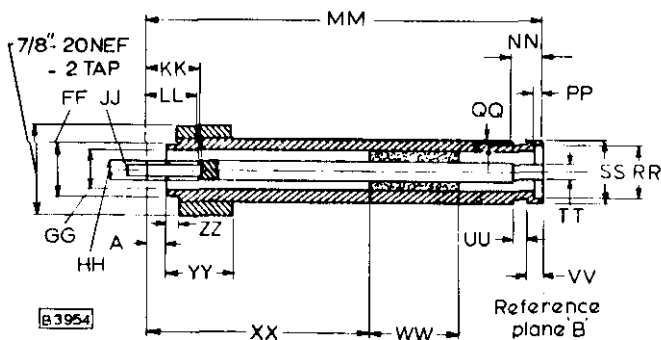

DIMENSIONS

	Millimetres	Inches	
FF	12.6 ± 0.05	0.496 ± 0.002	dia.
GG	11.1 ± 0.15	0.437 ± 0.006	dia.
HH	4.8 ± 0.05	0.189 ± 0.002	dia.
JJ	3.85 ± 0.05	0.152 ± 0.002	dia.
KK	14	0.55	
LL	13	0.51	
MM	105	4.13	
NN	7.2 ± 0.1	0.283 ± 0.004	
PP	2.0 ± 0.15	0.079 ± 0.006	
QQ	1.5	0.059	
RR	12.8 ± 0.15	0.504 ± 0.006	dia.
SS	15 ± 0.2	0.591 ± 0.008	dia.
TT	3.8 ± 0.05	0.150 ± 0.002	dia.
UU	2.8 ± 0.2	0.110 ± 0.008	
VV	4.0 ± 0.2	0.157 ± 0.008	
WW	22 ± 0.1	0.866 ± 0.004	
XX	57.5 ± 0.2	2.264 ± 0.008	
YY	16	0.63	
ZZ	3.0	0.118	
A	5.0 0.1	0.197 - 0.004	

Inch dimensions derived from original millimetre dimensions.

## RIEKE DIAGRAM

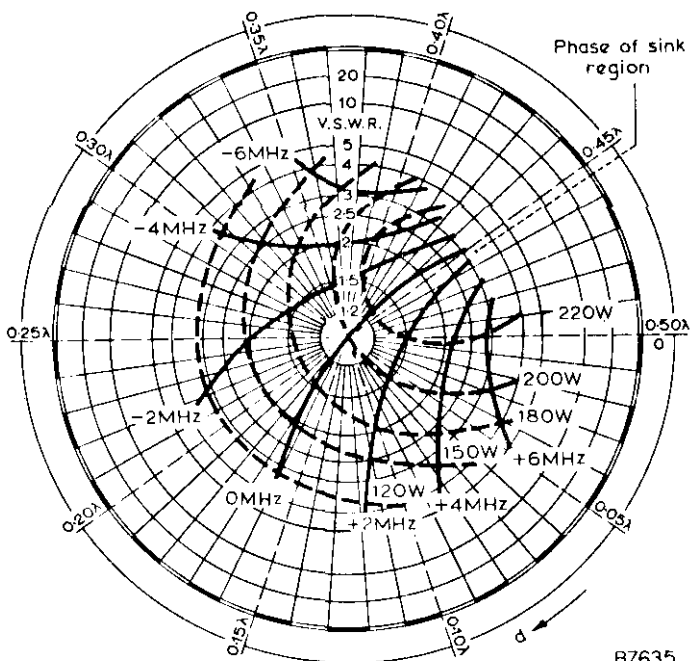

Measured with a.c. supply  $I_a = 0.2A$

- Output power
- Frequency pulling
- d distance of standing wave minimum from reference plane 'A' towards load.

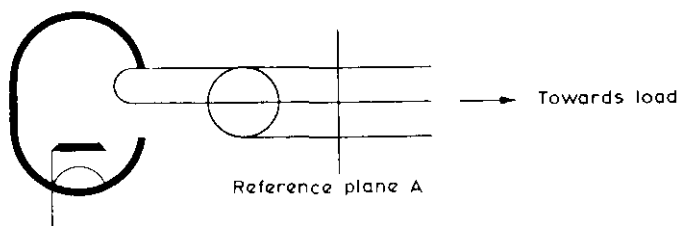

[REDACTED]

[REDACTED]

[REDACTED]

[REDACTED]

[REDACTED]

[REDACTED]

[REDACTED]

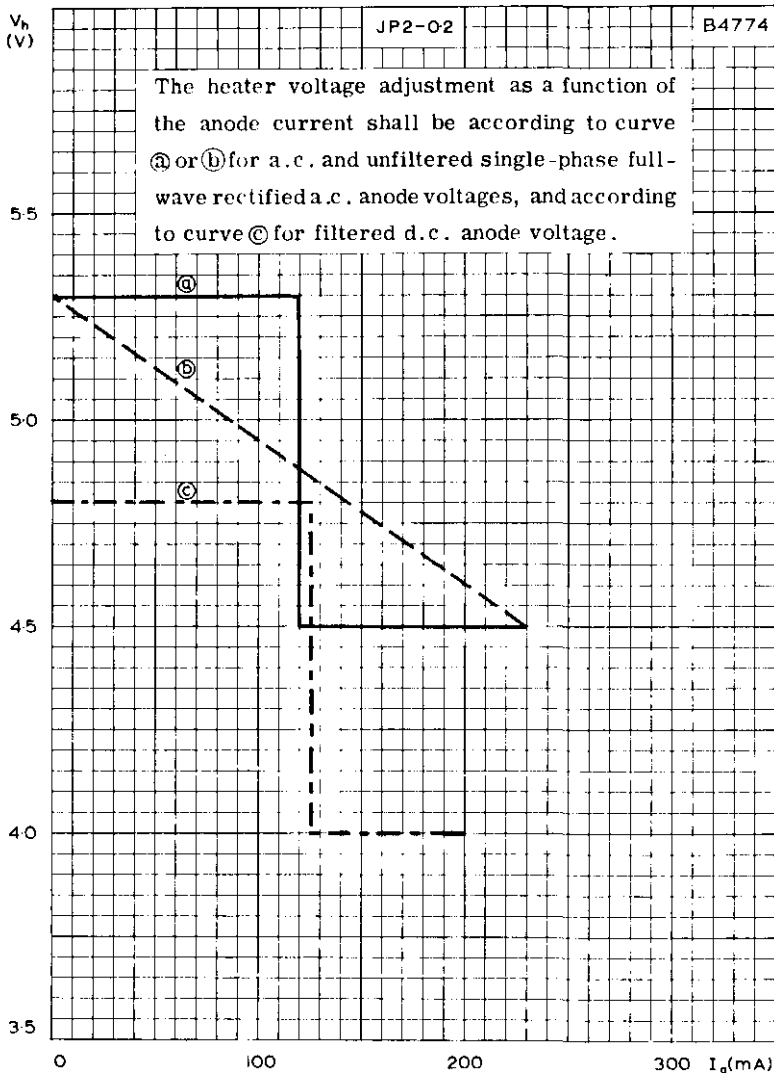

HEATER VOLTAGE PLOTTED AGAINST MEAN ANODE CURRENT

# MAGNETRON ACCESSORIES

JP2-2.5A, 2.5W, 5W

## OUTLINE AND DIMENSIONS OF CAP NUT AND COAXIAL OUTPUT

	<i>Inches</i>	<i>Millimetres</i>		<i>Inches</i>	<i>Millimetres</i>
A	0.5905 ± 0.0078	15.0   0.2	K	1.77	45
B	2.05	52	L	0.51	13
C	1.9528 ± 0.0020	49.6 ± 0.05	M	0.51	13
D	0.3149 ± 0.0039	8.0 ± 0.1	N	0.217	5.5
E	0.3740 ± 0.0039	9.5 ± 0.1	Q	0.138	3.5
F	0.4330 ± 0.0039	11.0 ± 0.1	R	0.63	16
G	1.7913 ± 0.0020	45.5 ± 0.05	S	0.315	8.0
H	2.1653 ± 0.0078	55.0 ± 0.2	T	0.768	19.5
J	2.4409 ± 0.0078	62.0 ± 0.2			

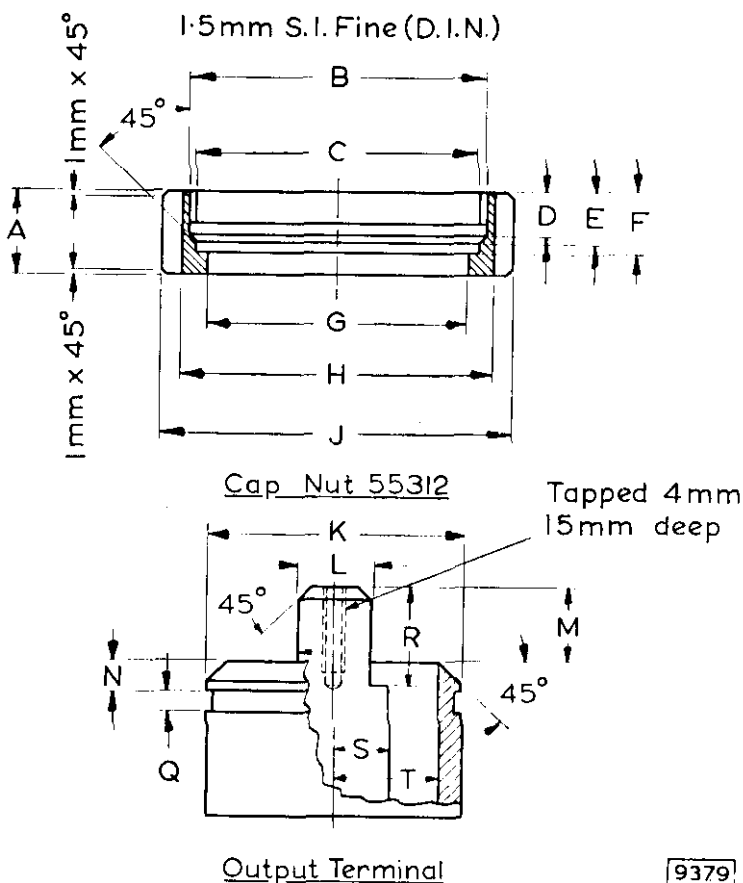

9379

# MAGNETRON ACCESSORIES

JP2-2.5A, 2.5W, 5W

## OUTLINE AND DIMENSIONS OF COOLING CLIPS

	<i>Inches</i>	<i>Millimetres</i>		<i>Inches</i>	<i>Millimetres</i>
AB	1.06	27	AK	1.02	26
AC	0.41	10.5	AL	0.35	9
AD	0.51	13	AM	0.47	12
AE	1.10	28	AN	1.10	28
AF	0.47	12	AP	0.47	12
AG	1.18	30	AQ	1.18	30
AH	0.26	6.5	AR	0.26	6.5
AJ	0.47	12	AS	0.47	12

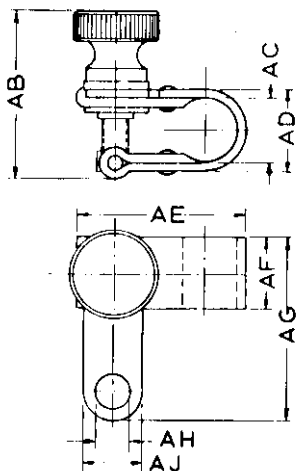

Cathode terminal  
cooling clip 40649

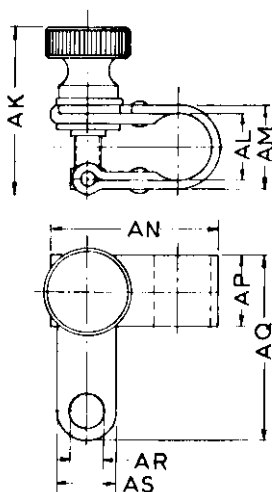

heater terminal  
cooling clip 40634

9177

## QUICK REFERENCE DATA

Magnetrons for microwave heating applications  
 JP2-2.5A (YJ1162) is forced-air cooled  
 JP2-2.5W (YJ1160) is water cooled

Frequency	2.45	Gc/s
Power output	2.5	kW
Construction	Packaged, high stability ticonal magnet	

Unless otherwise shown data is applicable to both types

To be read in conjunction with

## GENERAL OPERATIONAL RECOMMENDATIONS - MICROWAVE DEVICES

## CHARACTERISTICS

	Min.	Max.
Frequency fixed within the band	2.425	2.475 Gc/s
Operating voltage range (d.c.), within the range (at $I_a = 750\text{mA d.c.}$ , v.s.w.r. < 1.05)	4.4	4.8 kV
Operating voltage range (d.c.), within the range (at $I_a = 800\text{mA d.c.}$ , v.s.w.r. = 3.0 in "phase of sync")	4.6	5.0 kV
"Phase of sync" from the reference plane (see drawings) towards load (nominal)	0.40	$\lambda$

# OPERATION IN MICROWAVE OVEN WITH FIELD STIRRER, WITH SINGLE-PHASE FULL-WAVE RECTIFIER WITHOUT SMOOTHING FILTER

## OPERATING CONDITIONS

For this condition the centre of the locus of the load impedance seen by the magnetron to be at v.s.w.r. = 3.0 in "phase of sync". The impedance of the h.t. supply should be greater than 500Ω. In addition, a limiting resistor of 300Ω should be inserted in series with the magnetron.

Heater voltage (running)	1.7	V
Mean anode current	800	mA
Peak anode current	2.0	A
Load mismatch (v.s.w.r.)		
in the region of $\pm 0.1\lambda$		
about "phase of sync"	3.0	
instantaneous value*	5.0	
in the remaining region	2.5	
Power output (v.s.w.r. = 3.0 in "phase of sync")	2.5	kW

## RATINGS (ABSOLUTE MAXIMUM SYSTEM)

	Min.	Max.	
Heater voltage (starting)	4.5	5.2	V
Mean anode current	100	850	mA
Peak anode current	-	2.1	A
Load mismatch (v.s.w.r.)			
in the region of $\pm 0.1\lambda$			
about "phase of sync"	-	4.0	
instantaneous value*	-	10	
in the remaining region	-	4.0	

\*Maximum duration 20ms, maximum duty ratio 0.2. Moding must be avoided by the use of an appropriate coupling system.

OPERATION IN MICROWAVE OVEN WITHOUT FIELD STIRRER OR INDUSTRIAL APPLICATION WITH SINGLE-PHASE FULL-WAVE RECTIFIER WITHOUT SMOOTHING FILTER

## OPERATING CONDITIONS

The impedance of the h.t. supply should be greater than  $500\Omega$ . In addition, a limiting resistor of  $300\Omega$  should be inserted in series with the magnetron.

Heater voltage (running)	2.0	V
Mean anode current	750	mA
Peak anode current	2.0	A
Load mismatch (v.s.w.r.)	3.0	
*Power output (matched load)	2.0	kW

\*For the output power under conditions of mismatch, see the Rieke diagram on page C5.

## RATINGS (ABSOLUTE MAXIMUM SYSTEM)

	Min.	Max.	
Heater voltage (starting)	4.5	5.2	V
Mean anode current	100	800	mA
Peak anode current	-	2.1	A
Load mismatch (v.s.w.r.)			
in the region of $+0.03\lambda$			
about "phase of sync"	-	4.0	
in the remaining region	-	5.0	

# OPERATION IN MICROWAVE OVEN WITHOUT FIELD STIRRER FROM SINGLE-PHASE SUPPLY WITHOUT RECTIFIER

## OPERATING CONDITIONS

A limiting inductance of 2.25H must be inserted in series with the magnetron.

Heater voltage (running)	3.4	V
Mean anode current	400	mA
Peak anode current	2.0	A
Load mismatch (v.s.w.r.)	2.0	
*Power output (matched load)	1.0	kW

\*For the output power under conditions of mismatch, see the Rieke diagram on page C5.

## RATINGS (ABSOLUTE MAXIMUM SYSTEM)

	Min.	Max.	
Heater voltage (starting)	4.8	5.2	V
Mean anode current	-	500	mA
Peak anode current	-	2.1	A
Load mismatch (v.s.w.r.)			
in the region of $\pm 0.03\lambda$			
about "phase of sync"	-	4.0	
in the remaining region	-	5.0	

**OPERATION IN INDUSTRIAL APPLICATION WITH FIXED REFLECTION  
 ELEMENT AND THREE-PHASE HALF-WAVE RECTIFIER WITHOUT  
 SMOOTHING FILTER**

To obtain optimum power output, it is necessary to insert between the magnetron and the load, a fixed reflection element (see page D9) giving a mismatch with v.s.w.r. of 1.5 in "phase of sync".

**OPERATING CONDITIONS**

The impedance of the h.f. supply should be greater than  $350\Omega$ .

Heater voltage (running)	1.5	V
Mean anode current	850	mA
Peak anode current	2.0	A
*Load mismatch (v.s.w.r.)	1.5	
*†Power output (matched load)	2.5	kW

† For the output power under conditions of mismatch, see the Rieke diagram on page C4.

**RATINGS (ABSOLUTE MAXIMUM SYSTEM)**

	Min.	Max.	
Heater voltage (starting)	4.5	5.2	V
Mean anode current	100	900	mA
Peak anode current	-	2.1	A
*Load mismatch (v.s.w.r.)			
in the region of $\pm 0.03\lambda$			
in "phase of sync"	-	2.5	
in the remaining region	-	4.0	

\* Excludes fixed reflection element

## CATHODE

Indirectly heated, dispenser type

$V_h$ (starting)	5.0	V
$I_h$ (at $V_h = 5.0V$ )	35	A
$r_h$ (cold)	0.02	$\Omega$
$I_h$ (surge) max.	140	A

For a heater starting voltage in the range 5.0 to 5.2V the cathode must be heated for at least 2 minutes before the application of h.t. At a heater starting voltage of 4.5V the heating time must be increased to at least 3 minutes. For a heater starting voltage in the range 4.5 to 5.0V the minimum heating time can be determined by linear interpolation.

It is necessary to reduce the heater voltage immediately after the application of anode power to compensate for additional heating of the cathode by back bombardment. The correct value of the nominal heater voltage is given by the curve (full line) on page C6.

Where it is required to design a heating generator for several fixed output power levels, the heater voltage may be reduced in one or two steps depending on the anode current range. The appropriate nominal value of heater voltage is that which falls within the limit curves (dotted lines) for the appropriate operating currents. The deviation from the nominal should be kept to a minimum.

\*\*Temporary fluctuations not exceeding +5% and -10% of the nominal heater voltage are permissible.

## COOLING

## Maximum temperatures

Anode block reference point (see page D9)	125	°C
Cathode radiator	180	°C

## Cathode

Cooling clips 40634 and 40649 should be attached to the heater and cathode terminals respectively.

A flow of air should be directed at the cathode radiator in order to keep it below the stated maximum. This should not be allowed to cool the supporting glassware.

Due to the thermal capacity of the cathode if heater and air flow are switched off simultaneously the maximum temperature of the cathode radiator will be exceeded unless the cathode radiator is kept at approximately 100°C during operation. This requires a minimum air flow of 8.0ft<sup>3</sup>/min. (0.22m<sup>3</sup>/min). If after blowing is provided the minimum air flow may be reduced to 2.0ft<sup>3</sup>/min. (0.06m<sup>3</sup>/min.).

## JP2-2.5A (YJ1162)

## Forced-air cooled (see curve on page C2)

## Example: -

Under open bench conditions with a matched load, for operation from three-phase or single-phase supplies with rectifier  $T_{in} = 25^{\circ}\text{C}$ , the minimum air flow is 60ft<sup>3</sup>/min. (1.7m<sup>3</sup>/min.) at pressure of 15mm water.

When operating in a confined enclosure causing an increased ambient temperature around the magnetron and with conditions of load mismatch causing reduced efficiency the amount of forced-air cooling will need to be increased.

A plate is provided on the anode block for the mounting of a thermal switch to protect the valve in the event of failure of the cooling air. This switch should come into operation at a temperature not higher than 105°C.

## JP2-2.5W (YJ1160)

## Water cooled (see curve on page C3)

A plate is provided on the anode block for the mounting of a thermal switch to protect the valve in the event of water failure. This switch should come into operation at a temperature not higher than 120°C.

## MOUNTING POSITION

In equipment, the following minimum distances should be maintained between the magnet and magnetic materials (see outline drawings).

direction a	60	mm
direction b	100	mm
direction c	110	mm

## OUTPUT CONNECTION

50Ω coaxial transmission line with 16mm inner conductor and 39mm outer conductor.

## PHYSICAL DATA

	JP2-2,5A (YJ1162)	JP2-2,5W (YJ1160)	
Net weight of magnetron	17.4	11.2	lb
	7.9	5.1	kg

## ACCESSORIES

Cap nut	55312
Split spring ring	55313
Heater terminal cooling clip	40634
Cathode terminal cooling clip	40649





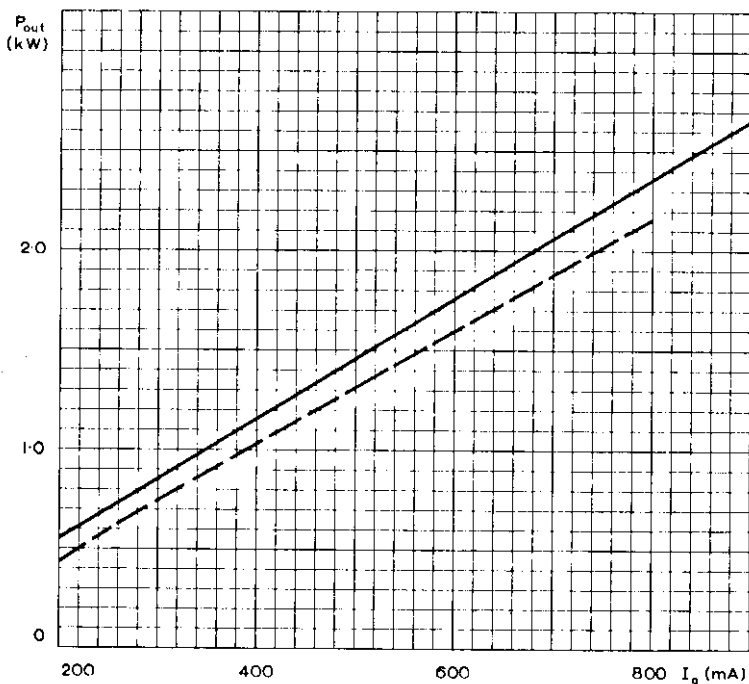
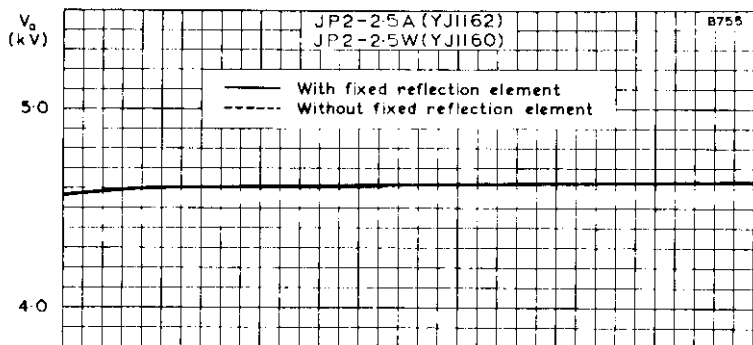

OUTPUT POWER AND ANODE VOLTAGE PLOTTED AGAINST MEAN ANODE CURRENT

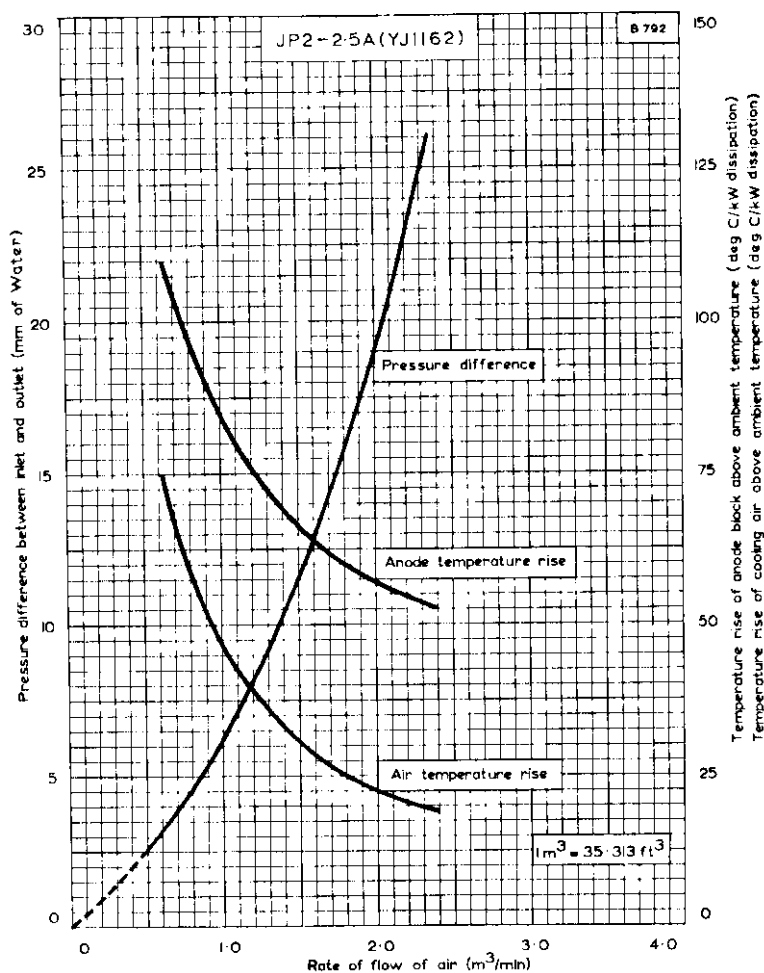

COOLING CURVES FOR JP2-2.5A (YJ1162)

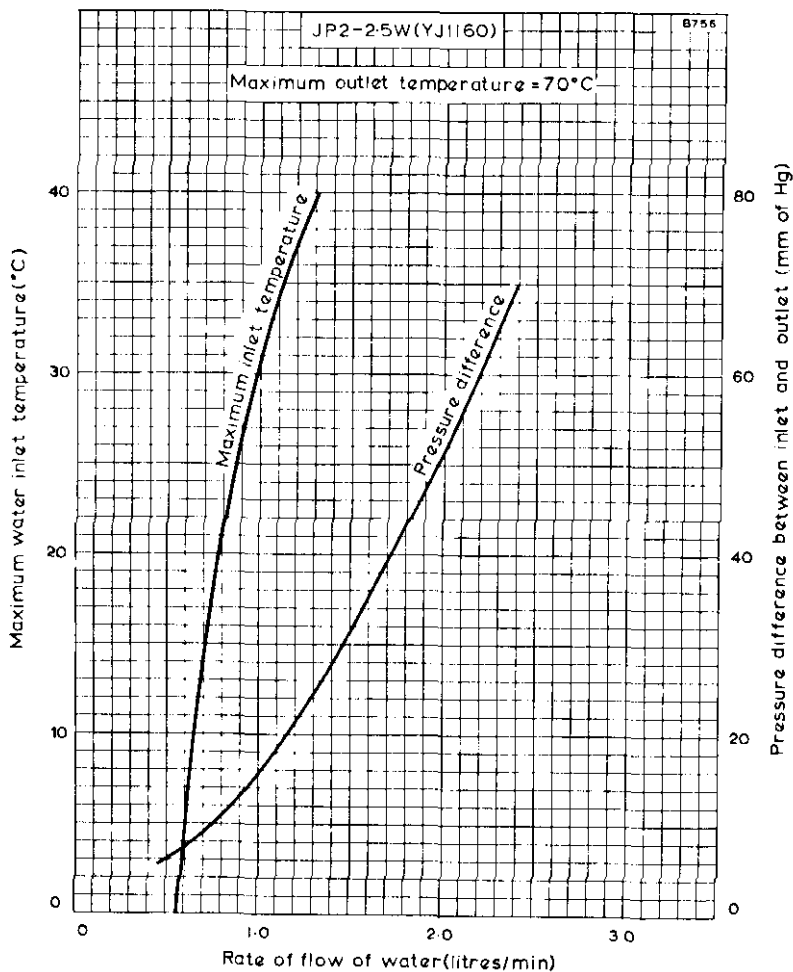

COOLING CURVES FOR JP2-2.5W (YJ1160)

Measured at:  $I_a = 850 \text{ mA}$

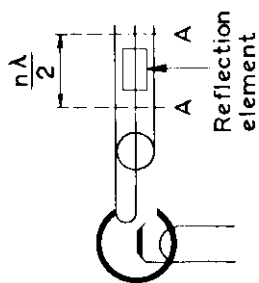
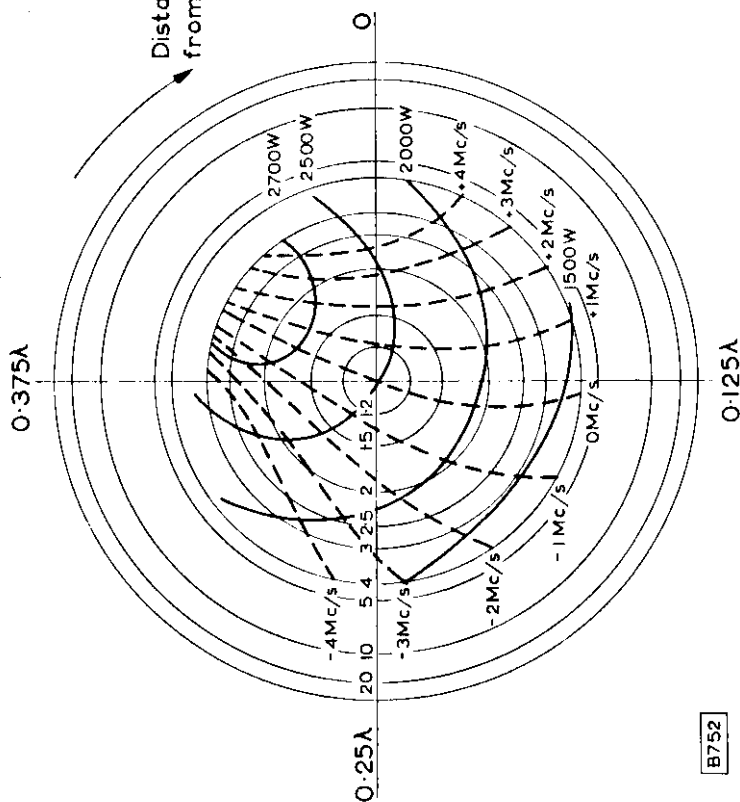

RIEKE DIAGRAM (WITH REFLECTION ELEMENT)

B752

Measured at:

$I_a = 750 \text{ mA}$

$i_{a(pk)} = 2.0 \text{ A}$

— Output power  
 - - - Frequency pulling

	Pout (kW)	
	Single phase unsmoothed full-wave	Self rectified a.c.
a	2.25	1.125
b	2.00	1.000
c	1.75	0.875
d	1.50	0.750
e	1.25	0.625
f	1.00	0.500

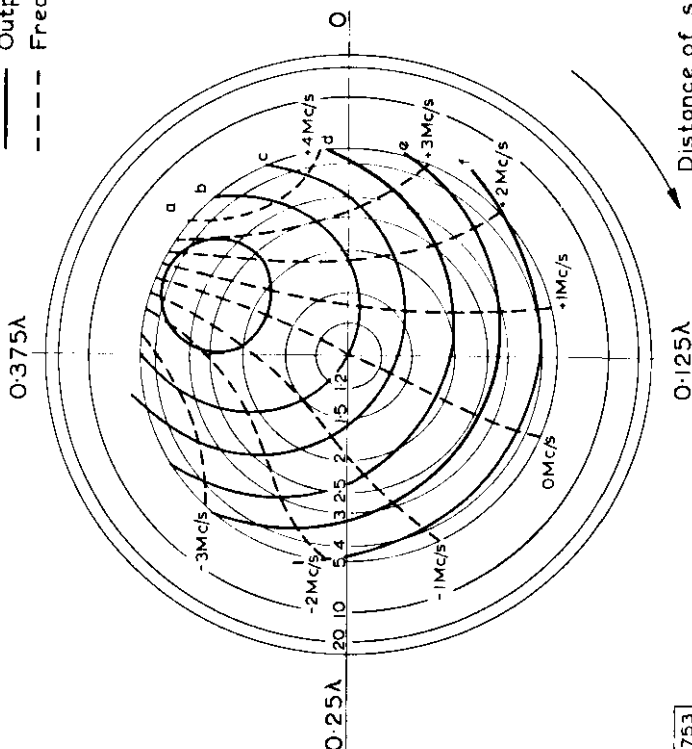
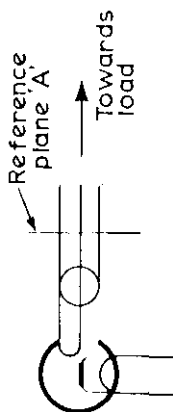

Distance of standing wave minimum from reference plane A towards load

RIEKE DIAGRAM (WITHOUT REFLECTION ELEMENT)

B753

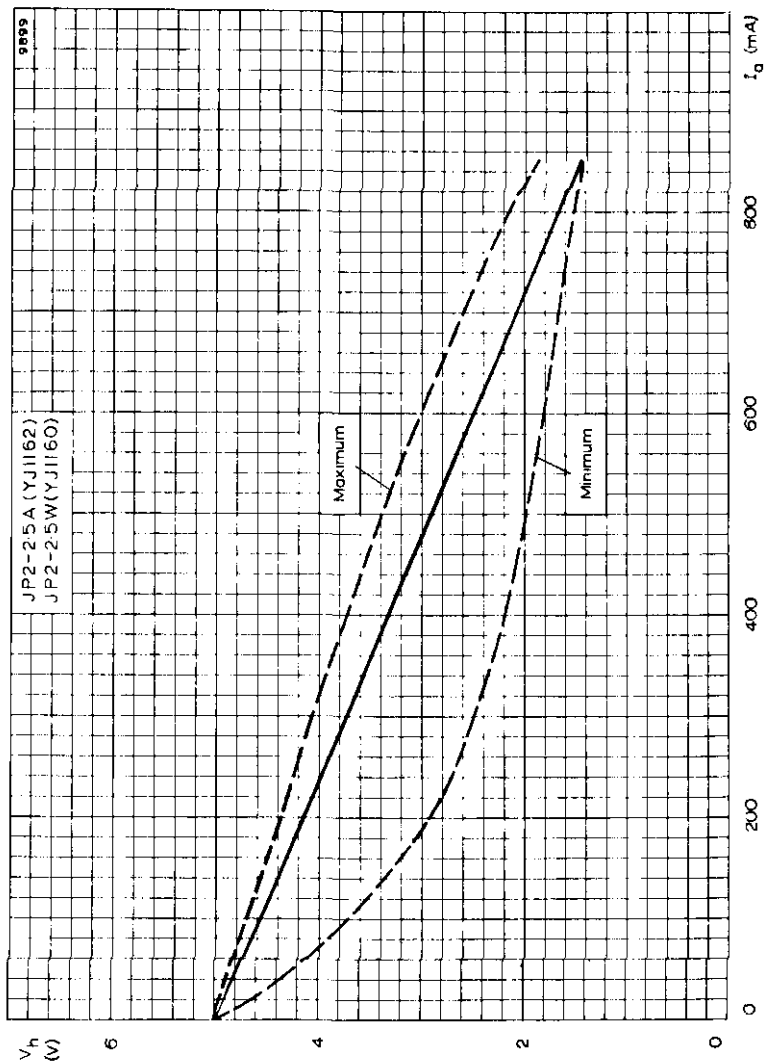

HEATER VOLTAGE PLOTTED AGAINST MEAN ANODE CURRENT

## TENTATIVE DATA

## QUICK REFERENCE DATA

Continuous wave air and water-cooled magnetron intended for microwave heating applications.

Frequency (fixed within the band)	2.425 to 2.475	GHz
Power output	5.0	kW
Construction	Packaged, ceramic and metal	

To be read in conjunction with  
GENERAL OPERATIONAL RECOMMENDATIONS - MICROWAVE DEVICES

## OPERATING CONDITIONS

Typical operation from d.c. or low peak current (L-C stabilised) supply.

Frequency (see note 1)	2.45	GHz
Power output	5.0	kW
Anode voltage	7.1	kV
Mean anode current (see note 2)	1.25	A
Peak anode current	1.5	A
Filament voltage (running)	1.0	V
Load v. s. w. r.	$\leq 1.05$	

## CATHODE

Directly heated a.c. 50 or 60Hz or d.c. Thoriated tungsten.

$V_f$ (starting and standby)		$5.5 \pm 10\%$	V
$I_f$ (at $V_f = 5.5V$ and $V_a = 0$ )	nominal	46	A
	max	50	A
$I_f$ (surge) max		120	A
$r_f$ (cold)		0.015	$\Omega$
Minimum waiting time before applying h.t.		30	s

The positive potential must be applied to the filament connector when the filament supply is d.c.



## CHARACTERISTICS

	Min.	Max.	
Frequency (fixed within the band) (see note 1)	2.425	2.475	GHz
Anode voltage (at $I_a = 1.25A$ ) (see notes 1, 2, 3)	6.8	7.2	kV
Distance of voltage standing wave minimum (see note 4)	0.36	0.42	$\lambda_{guide}$
Power output (at $I_a = 1.25A$ )	4.65	-	kW
Load v.s.w.r.	-	1.05	

## RATINGS (ABSOLUTE MAXIMUM SYSTEM)

	Min.	Max.	
Anode voltage (see note 5)	-	$\pm 12$	kV
Peak anode current	-	2.6	A
Mean anode current (see note 2)	0.3	1.3	A
Mean anode input power	-	9.6	kW
v.s.w.r. (from $0.3\lambda$ to $0.5\lambda$ )	-	2.5	
v.s.w.r. (remaining region)	-	1.5	

## OPERATING NOTES

1. Measured with a matched load (v.s.w.r.  $\leq 1.05$ )
2. Measured with a moving coil instrument.
3. The anode voltage should be measured with the magnetron operating on a filtered anode voltage obtained by three-phase full-wave rectification.
4. The distance is measured in the direction of the load, starting at the reference plane for electrical measurements using standard cold measurement techniques and a 16/39 coaxial line.
5. An 8mm spark gap near the input terminals is recommended to ensure that the maximum anode voltage is not exceeded.



## COOLING

**Anode block** Water  
For required quantity of water and pressure drop see page 14.

**Filament and filament/cathode connectors** Forced-air  
A low-velocity air flow perpendicular to the cathode axis is required.

**R. F. output system**  
A minimum air flow of  $0.1 \text{ m}^3/\text{min}$  is required at room temperature (typical  $18^\circ\text{C}$ ).

## Maximum temperatures

Anode block (see page 9 for reference point)	90	$^\circ\text{C}$
Cooling water outlet temperature	70	$^\circ\text{C}$
Filament and filament/cathode terminals and any other point	200	$^\circ\text{C}$

*At standby with filament voltage = 5.5V water and forced-air cooling is required to prevent overheating.*

A thermoswitch should be mounted at the point indicated on the outline drawing (see page 9). The switch should operate at a mounting disc temperature of  $85$  to  $90^\circ\text{C}$ .

## PHYSICAL DATA

Weight of magnetron (approx.)	6.0	kg
	13.2	lb

## MOUNTING POSITION

Axis of cathode vertical

## OUTPUT CONNECTION

The coaxial output system of the magnetron may be coupled by suitable means to a coaxial line or to a waveguide.

## ACCESSORIES

Filament connector	55323
Filament/cathode connector	55324
Cap nut (for output coupling)	55312
Snap ring	55313
Mounting plate	55327
Washer	55328
Cap nut (for cooling system)	TE1051b
Hose nipple (for 9mm hose)	TE1051c



## GENERAL

Whenever it is considered to operate the magnetron at conditions substantially different from those indicated, the magnetron manufacturer should be consulted.

Equipment design should be orientated around the magnetron specifications given in this data and not around one particular magnetron, since due to normal production variations, the design parameters ( $V_a$ ,  $r_f(\text{cold})$ ,  $f$ ,  $P_{\text{out}}$ , etc.) will vary around the nominal values.

### Anode supply

The magnetron can be operated from an unfiltered three-phase full-wave supply unit. The design of the unit should be such that the limiting values for the mean and peak anode currents are not exceeded.

### Filament supply

The secondary of the filament transformer must be well insulated from the primary, since in normal magnetron operation the cathode will be at high negative potential and the anode will be earthed.

The transformer should be designed so that the filament voltage and surge current limits are not exceeded.

Immediately after applying the anode voltage the filament voltage must be reduced as a function of the anode current according to the diagram on page 14. The life of the magnetron will be greatest if the filament voltage is reduced to a value given by the fully drawn line 'a'. The filament voltage should be adjusted within 10% as given by the dashed lines which border the hatched area.

If it is intended to design the equipment for a predetermined number of steps in output power level, the reduced filament voltage for each step must be set to a value within the area bordered by the lines 'b' and 'c', and preferably within or close to the hatched area.

The filament voltage should be maintained within the limits given by the lines 'b' and 'c'.

### Filament connections

It is important to ensure that the filament connections make good electrical and mechanical contact due to the high filament current. This will prevent the temperature of the filament connections rising due to the *high contact resistance*. *Bad electrical contacts cause voltage drop and thus lower the filament voltage which may result in reduced efficiency of operation.* The filament connectors (see page 10) have been designed to ensure effective electrical and mechanical contact. A high temperature resistant silicone grease is recommended to prevent oxidation of the filament contacts.

The electrical conductors to the cathode and filament connectors should be flexible in order to prevent undue stress on the terminals.

### Load impedance

Optimum output power and life will be obtained when the magnetron is loaded with an impedance giving a v.s.w.r. of approximately 1.5 in the phase of sink region. This phase condition is reached when the position of the voltage standing wave minimum is at a distance of about 0.39 $\lambda$ guide from the reference plane for electrical measurements (see outline drawing page 8) in the direction of the load.



## GENERAL (cont'd)

## Antenna

When an antenna is used, the coaxial coupling should be according to the figure below:-

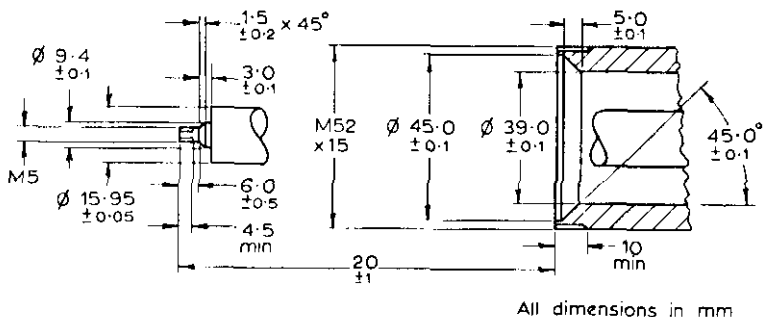

A soft copper washer of 0.5mm thickness is required between the antenna and the magnetron to ensure reliable r.f. contact. The maximum torque applied when screwing the antenna coupling into the magnetron is 15kg cm (13lb in).

## Cooling

The r.f. output system of the magnetron is provided with air inlet and outlet holes for the application of at least  $0.1m^3/min$  of cooling air to the ceramic part inside. All air inlet holes must be used to obtain the required uniform cooling. The cooling air must be filtered to be free from dust, water and oil. For an example of a cooling device around the output system see the drawing on page 12.

To prevent the magnetron from overheating if the anode cooling fails, provision is made for mounting a thermoswitch which should operate within a mounting disc temperature of 85 to 90°C (see page 8)

A stream of cooling air should also be directed at the input connectors and should be perpendicular to the cathode axis.

The type TE1051c hose nipple is suitable for connecting a flexible hose or soldering to a metal water pipe.

## Shielding

Where required, r.f. radiation from the filament terminals may be reduced by external filtering and/or shielding. A filter box of non-magnetic material may be mounted on the aluminium top cover plate of the magnetron. For drilling and tapping the cover plate must be removed. The filter box mounting screws **must not** penetrate through the top cover plate (thickness 6mm). When removing and re-mounting the cover plate, non-magnetic tools should be used.

### Magnetron cleanliness

The ceramic insulation between the terminals of the magnetron must be kept clean. A protective cover of suitable material should be placed over the output terminal if the magnetron is inserted directly into a cavity. The cooling air should be filtered and ducted to prevent deposits forming on the insulation during operation.

## HANDLING, STORAGE, MOUNTING AND OPERATIONAL CHECKS

### Handling and storage

The original packing should be used for transporting and storing the magnetron.

Shipment of the magnetron mounted in equipment is not permitted unless specifically authorised by the magnetron manufacturer.

When the magnetrons have to be unpacked, e.g. at an assembly line or for measurement purposes, care should be taken to ensure that a minimum distance of 150mm (6in) is maintained between magnets. As the tungsten heaters are sensitive to shocks and vibrations, care should be taken when handling and storing unpackaged magnetrons that such shocks and vibrations are avoided. High intensity magnetic fields associated with transformers and other magnetic equipment can demagnetise the magnets. Such fields must not be present when the magnetrons are stored, handled or serviced.

The user should be aware of the strong magnetic fields around the magnetron. When handling and mounting the magnetron, non-magnetic tools must be used and extreme care taken to avoid damage to watches and other precision instruments nearby.

### Mounting

When magnetic materials are present in two or more planes, the minimum distance from the magnets is 130mm (5in) in all directions. Mounting holes may be drilled and tapped in the bottom cover plate when removed from the magnetron. The mounting screws must not penetrate through the bottom cover plate (thickness 6mm). A special mounting plate (type 55327) with 4 mounting holes as indicated in the drawing (see page 8), can be screwed to the bottom cover plate of the magnetron by removing the two existing M4 screws and replacing them by screws 15mm (0.6in) long.

For removing and re-mounting these plates non-magnetic tools should be used. When mounting the magnetron, all tools used close to or in contact with the magnetron must be made of non-magnetic material to avoid possible mechanical damage to ceramic parts as well as short-circuiting the magnetic flux by magnetic attraction.

The anode power supply lead should be connected to the terminal shown in the outline drawing (see page 8) or to one of the mounting screws.



## HANDLING, STORAGE, MOUNTING AND OPERATIONAL CHECKS(cont'd)

## Operational checks

Excessive v.s.w.r. and/or current values may lead to moding of the magnetron which can be detected by displaying the  $V_a/I_a$  characteristic of the magnetron on an oscilloscope. This should be done for various load conditions and should be part of production line inspection and of field inspection before and after magnetron replacement.

For x-y display on a service oscilloscope the anode voltage can be sampled from a voltage divider chain connected between earth and the cathode connector, and the anode current from a sampling resistor of a few ohms which may be permanently connected to the earth terminal of the high voltage supply unit.

*The normal characteristic should be a fairly straight loop. The appearance of a second loop or parts thereof showing distinctly above the first loop indicates undesired modes of oscillation that can rapidly lead to failure of the magnetron.*

Operating conditions including v.s.w.r. must be checked at once and the magnetron replaced if under the correct conditions moding still occurs. The mean anode current may be measured directly across the sampling resistor.

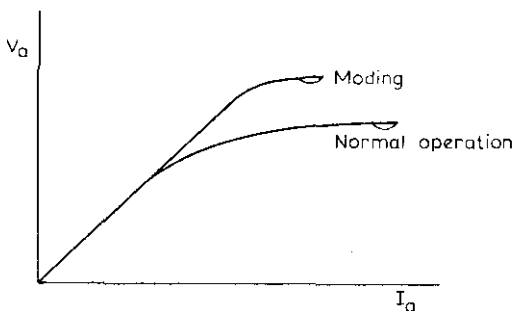

X-Y Display of magnetron characteristic

# OUTLINE DRAWING

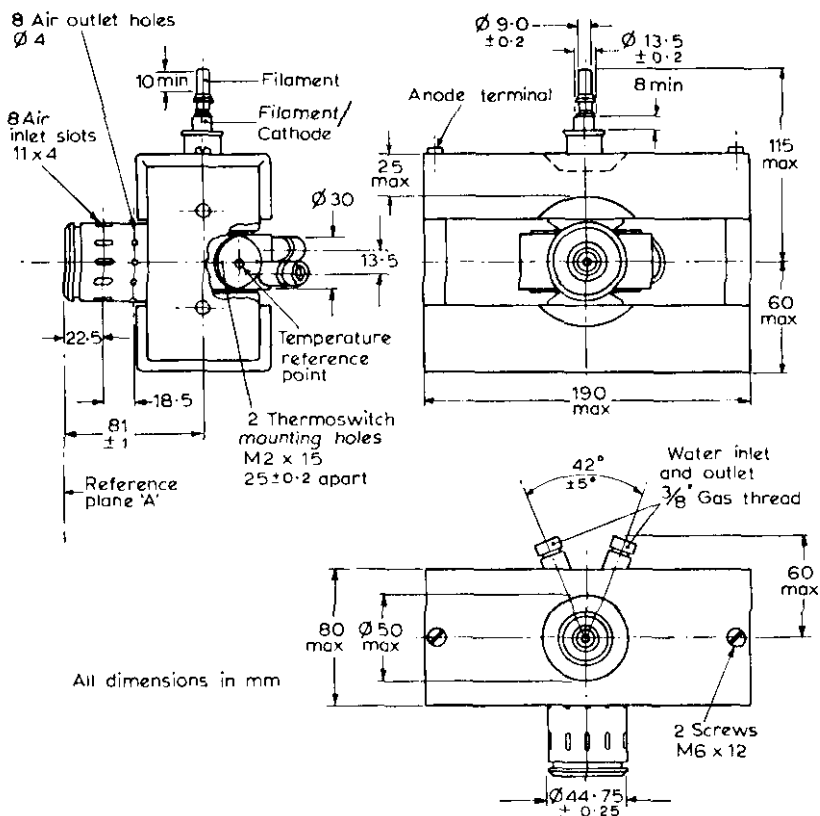

## MOUNTING PLATE 55327

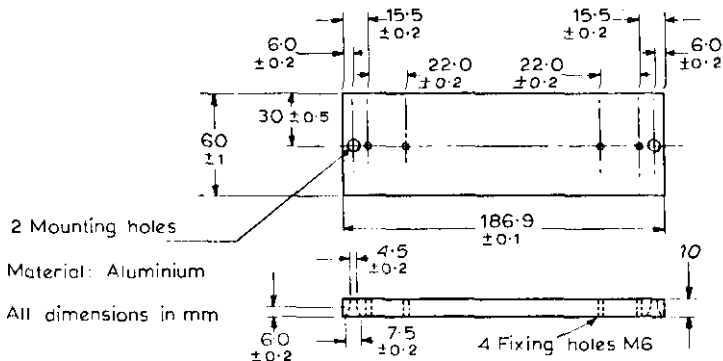

## MILLIMETRE TO INCH CONVERSION TABLE FOR OUTLINE DRAWING

Rounded outwards

Millimetres	Inches	
8.0	0.314	min
9.0 ± 0.2	0.3543 ± 0.0079	∅
10	0.393	min
13.5	0.532	
13.5 ± 0.2	0.5315 ± 0.0079	∅
18.5	0.728	
22.5	0.886	
25	0.99	max
25 ± 0.2	0.9842 ± 0.0079	
30	1.18	∅
44.75 ± 0.25	1.762 ± 0.010	∅
50	1.97	max
60	2.37	max
80	3.15	max
81 ± 1	3.189 ± 0.040	
115	4.528	max
190	7.49	max

Mounting plate 55327

4.5 ± 0.2	0.1772 ± 0.0079	∅
6.0 ± 0.2	0.2362 ± 0.0079	
7.5 ± 0.2	0.2953 ± 0.0079	∅
10	0.39	
15.5 ± 0.2	0.6102 ± 0.0079	
22 ± 0.2	0.8661 ± 0.0079	
30 ± 0.5	1.181 ± 0.020	
60 ± 1.0	2.362 ± 0.040	
186.9 ± 0.1	7.3582 ± 0.0040	

## ACCESSORIES

Inch dimensions given in conversion tables below are derived from original millimetre dimensions

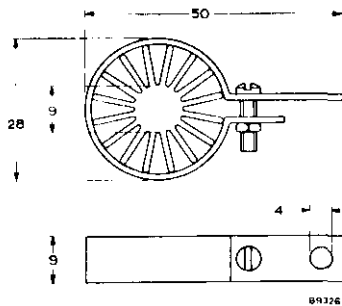
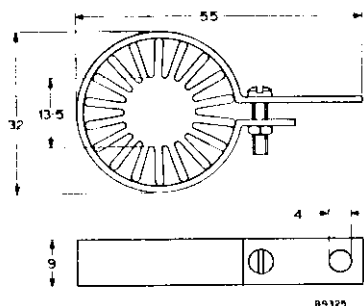

Filament/cathode connector  
55324

Millimetres	Inches
4 dia	0.16 dia
9	0.35
13.5 dia	0.532 dia
32 dia	1.26 dia
55	2.17

Filament connector  
55323

Millimetres	Inches
4 dia	0.16 dia
9	0.35
9 dia	0.35 dia
28 dia	1.10 dia
50	1.97

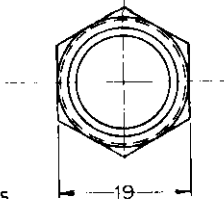
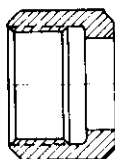

Thread  $3/8''$  gas

Cap nut  
TE1051b

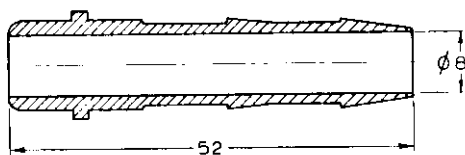

Connection for 9mm hose  
TE1051c

Millimetres	Inches
8 dia	0.31 dia
19	0.75
52	2.05



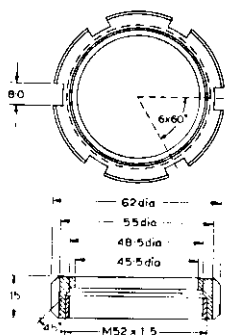

Cap nut  
55312

Millimetres	Inches
8.0	0.315
15	0.59
45.5 dia	1.791 dia
48.5 dia	1.909 dia
55 dia	2.165 dia
62 dia	2.441 dia

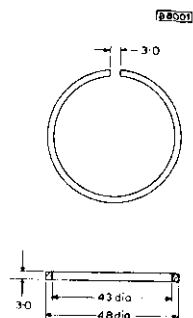

Snap ring  
55313

Millimetres	Inches
3.0	0.118
43 dia	1.69 dia
48 dia	1.89 dia

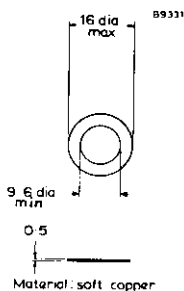

Material: soft copper

Washer  
55328

Millimetres	Inches
0.5	0.020
9.6 dia min	0.377 dia min
16 dia max	0.63 dia max

Example of a cooling device for output system

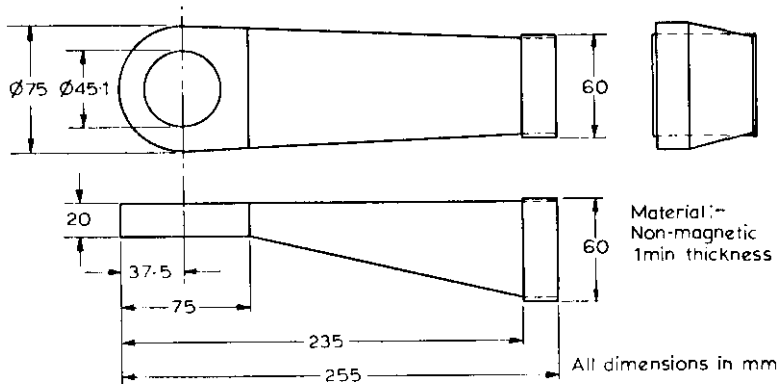

Pressure loss at  $0.1 \text{ m}^3/\text{min}$ :

About 60mm water with air outlet only via outlet holes.

About 30mm water if air can also escape towards the load through the waveguide or coaxial line.

Millimetres	Inches
20	0.79
37.5	1.476
45.1 dia	1.776 dia
60	2.36
75	2.95
75 dia	2.95 dia
235	9.25
255	10.04

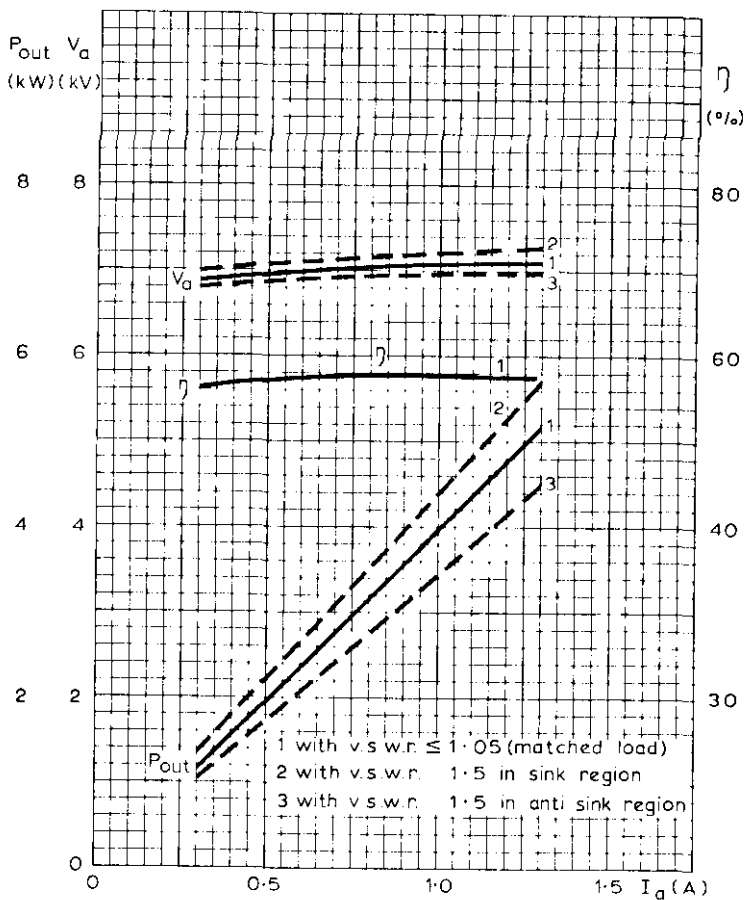

OUTPUT POWER, ANODE VOLTAGE AND EFFICIENCY  
PLOTTED AGAINST ANODE CURRENT

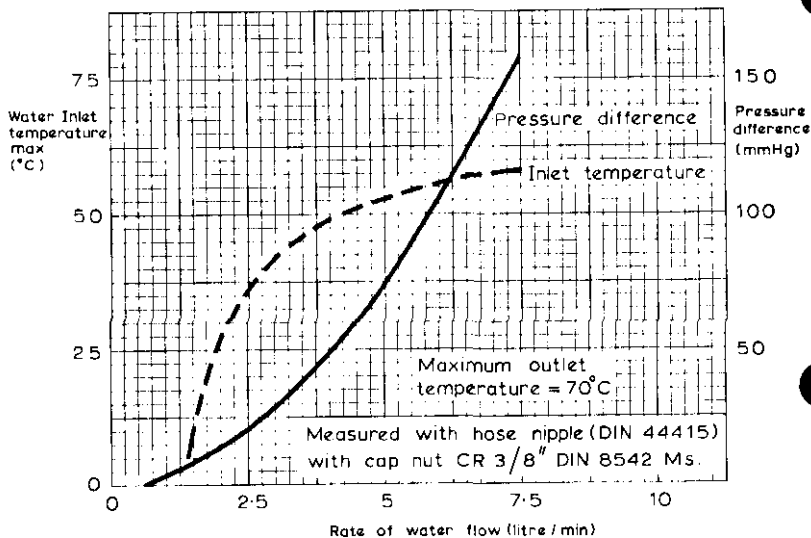

COOLING CHARACTERISTICS

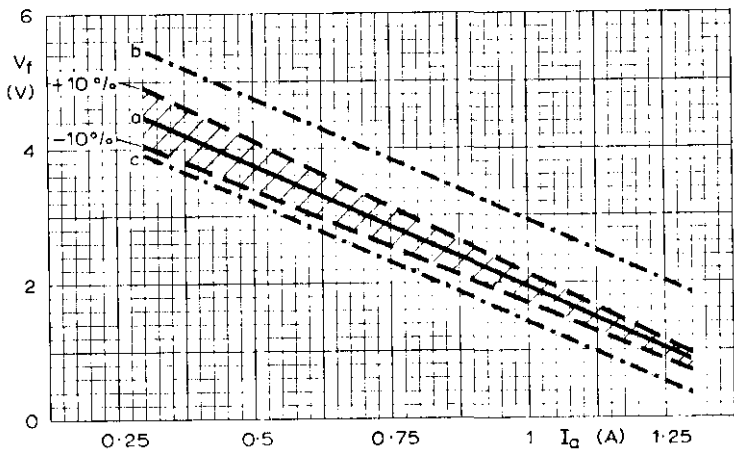

HEATER DERATING CHART

## TENTATIVE DATA

## QUICK REFERENCE DATA

Air-cooled c.w. magnetron for microwave heating applications.

Frequency (fixed within the band)	2.425 to 2.475	GHz
Power output (c.w.)	1.25	kW
Construction	Packaged, ceramic and metal	

To be read in conjunction with

## GENERAL OPERATIONAL RECOMMENDATIONS - MICROWAVE DEVICES

## OPERATING CONDITIONS

Typical operation from d.c. or low peak current (L-C stabilised) supply

Frequency (see note 1)	2.45	GHz
Power output	1.25	kW
Anode voltage	5.7	kV
Mean anode current (see note 2)	380	mA
Filament voltage (running)	3.5	V
Load v.s.w.r.	$\leq 1.05$	

## CATHODE

Directly heated a.c. 50 or 60Hz or d.c. Thoriated tungsten.

$V_f$ (starting and standby)		5.0 $\pm$ 10%	V
$V_f$ (running) at $I_a(\text{mean}) = 380\text{mA}$		3.5 $\pm$ 10%	V
$I_f$ (at $V_f = 5.0\text{V}$ and $V_a = 0$ )	nominal	28	A
	max.	32	A
$I_{f(\text{surge})}$ max.		70	A
$r_f$ (cold)		0.02	$\Omega$
Minimum waiting time before applying h.t.		10	s

The positive potential must be applied to the filament connector when the filament supply is d.c.

## CHARACTERISTICS

	Min.	Max.	
Frequency fixed within the band (see note 1)	2.425	2.475	GHz
Anode voltage (at $I_a = 380\text{mA}$ ) (see notes 1, 2 and 3)	5.4	5.8	kV
Distance of voltage standing wave minimum (see note 4)	0.03	0.09	$\lambda_g$
Power output (at $I_a = 380\text{mA}$ )	1.15	-	kW
Load v.s.w.r.	-	1.05	

## RATINGS (ABSOLUTE MAXIMUM SYSTEM)

	Min.	Max.	
Anode voltage (see note 5)	-	$\pm 10$	kV
Peak anode current (see note 5)	380	800	mA
Mean anode current (see note 2)	100	450	mA
Mean anode input power	-	2.7	kW
v.s.w.r. (continuous) (see note 6)	-	4.0	
v.s.w.r. (during max. 0.02s or 20% of the time whichever is the smaller. See notes 6 and 7)	-	10	

## OPERATING NOTES

1. Measured with a matched load (v.s.w.r.  $\leq 1.05$ )
2. Measured with a moving coil instrument.
3. The anode voltage should be measured with the magnetron operating on a filtered anode voltage obtained by single-phase or three-phase full-wave rectification, the peak anode current should not exceed 480mA, with 380mA as the mean value.
4. The distance is measured outside the magnetron, starting at the reference plane for electrical measurements (see page 8), a standard cold measuring technique is used with a matched load.
5. An 8mm spark gap near the input terminals is recommended to ensure that the maximum anode voltage is not exceeded.
6. Determined with adaptor 55336.
7. Any interval at which the v.s.w.r. is between 4 and 10 must be followed by an interval four times as long, during which the v.s.w.r. is  $\leq 4$ . When operating under these conditions the magnetron should not be permitted to mode.

## COOLING

Anode block		Forced-air
Filament terminals		Forced-air
<b>Maximum temperatures</b>		
Anode block (see page 8 for reference point)	180	°C
* Filament and filament/cathode terminal	250	°C
Any other point	200	°C
<b>Inlet air, typical</b>		
Temperature	35	°C
Rate of air flow	1.2	m <sup>3</sup> /min
Pressure drop	10	mm water

At standby, with filament voltage  $\approx 5.0V$  forced-air cooling is required to keep the temperature of the filament terminal and filament/cathode terminal below the stated maximum limit.

A thermoswitch should be mounted at the point indicated on the outline drawing (see pages 8 and 11).

\* For maximum valve life it is recommended that the operating temperature be less than 200°C.

## PHYSICAL DATA

Weight of magnetron (approx.)	2.3	kg
	5.1	lb

## OUTPUT CONNECTION

Probe output suitable for coupling to waveguide, coaxial line or directly to a cavity.

## MOUNTING POSITION

Axis of cathode vertical

## ACCESSORIES

Filament/cathode connector		55324
Filament connector		55323
R.F. gasket (1 supplied)		S-330109
Thermoswitch	4.5A max.	S-32997
	25A max.	S-330923
Washer		55328
<i>Coupling adaptor for measurement purposes only</i>		55336
Air inlet duct		



## GENERAL

Whenever it is considered to operate the magnetron at conditions substantially different from those indicated, the magnetron manufacturer should be consulted.

Equipment design should be orientated around the magnetron specifications given in this data and not around one particular magnetron, since, due to normal production variations, the design parameters ( $V_a$ ,  $r_f(\text{cold})$ ,  $f$ ,  $P_{\text{out}}$  etc.) will vary around the nominal values.

### Anode supply

The magnetron should be operated from an L-C stabilised anode supply unit. The design of the unit should be such that the limiting values for the mean and peak anode currents are not exceeded.

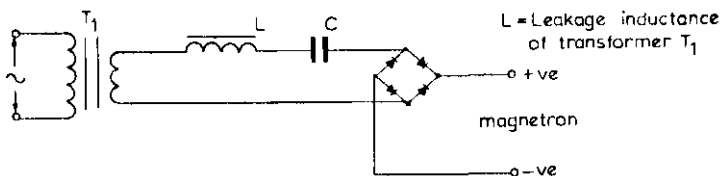

Basic series resonant circuit of an L-C power supply

### Filament supply

The secondary of the filament transformer must be well insulated from the primary since in normal magnetron operation the cathode will be at high negative potential and the anode will be earthed.

The transformer should be designed so that the filament voltage and surge current limits are not exceeded.

### Filament connections

It is important to ensure that the filament connections make good electrical and mechanical contact due to the high filament current. This will prevent the temperature of the filament connections rising due to high contact resistance. Bad electrical contacts cause voltage drop and thus lower the filament voltage which may result in reduced efficiency of operation. The filament connectors shown in the drawing (page 10) have been designed to ensure effective electrical and mechanical contact. A high temperature resistant silicone grease is recommended to prevent oxidation of the filament contacts.

The electrical conductors to the cathode and filament connectors should be flexible in order to prevent undue stress on the terminals.

### Load impedance measured with coupling adaptor

Using type 55336 coupling adaptor enables the designer of microwave heating equipment to determine the value of the load impedance (v. s. w. r. and phase of reflection as seen by the magnetron) using standard cold measuring techniques, and to arrive at the correct coupling for the magnetron. The adaptor simulates the r.f. output system of the magnetron; it may be coupled either to a waveguide or directly into a cavity in place of the magnetron, in both cases the type S-330109 gasket should be used.



## GENERAL (cont'd)

**Load impedance measured with coupling adaptor (cont'd)**

In order to obtain efficient operation, the magnetron should be loaded in the phase of sink.

The average mismatch of the cavity should not be higher than a v.s.w.r. of approximately 3 with the position of the voltage standing wave minimum about  $0.33\lambda$  from the reference plane in the direction of the load. (See adaptor outline drawing page 11).

**Antenna**

When an antenna is used, the part of the antenna screwed into the magnetron should be according to the figure below:-

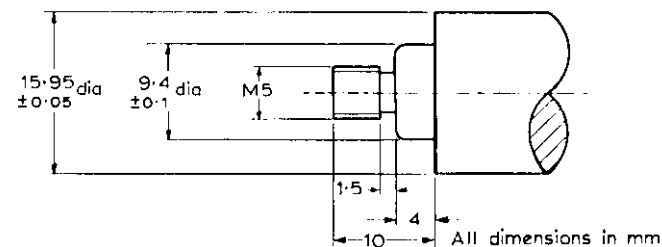

Inch dimensions derived from original millimetre dimensions

Millimetres	Inches	Millimetres	Inches
1.5	0.06	10	0.39
4	0.16	15.95±0.05 dia	0.628±0.002 dia
9.4±0.1 dia	0.370±0.004 dia		

A soft copper washer of 0.5mm thickness is required between the antenna and the magnetron to ensure reliable r.f. contact. The maximum torque applied when screwing the antenna into the magnetron is 15kg cm (13lb in).

**Standby operation**

Without anode voltage, the filament voltage during any standby period should be kept at  $V_f = 5.0V$ . Forced-air cooling will be required to prevent overheating.

Full anode voltage may be applied immediately after an initial waiting time of 10 seconds minimum or after a standby period with  $V_f = 5.0V$ . Microwave energy is then normally available in less than one second.



### Shielding

Where required r.f. radiation from the filament terminals may be reduced by external filtering and/or shielding.

### Magnetron cleanliness

The ceramic insulation between the terminals of the magnetron must be kept clean. A protective cover of suitable material should be placed over the output terminal if the magnetron is inserted directly into a cavity.

The cooling air should be filtered and ducted to prevent deposits forming on the insulation during operation.

## HANDLING, STORAGE, MOUNTING AND OPERATIONAL CHECKS

### Handling and storage

The original packing should be used for transporting and storing the magnetron.

Shipment of the magnetron mounted in equipment is not permitted unless specifically authorised by the magnetron manufacturer.

When the magnetrons have to be unpacked, e.g. at an assembly line or for measurement purposes, care should be taken to ensure that a minimum distance of 150mm (6in) is maintained between magnets. As the tungsten heaters are sensitive to shocks and vibrations, care should be taken when handling and storing unpackaged magnetrons that such shocks and vibrations are avoided. High intensity magnetic fields associated with transformers and other magnetic equipment can demagnetise the magnets. Such fields must not be present when the magnetrons are stored, handled or serviced.

The user should be aware of the strong magnetic fields around the magnetron. When handling and mounting the magnetron, non-magnetic tools must be used and extreme care taken to avoid damage to watches and other precision instruments nearby.

### Mounting

When magnetic materials are present in two or more planes, the minimum distance from the magnets is 130mm (5in) in all directions. In order to ensure a good r.f. contact between the output of the magnetron and the circuit in which it is connected, the use of gasket S-330109 is essential. The output coupling of the magnetron should not be used as the only means of mounting. The magnetron should be mounted and secured by the two mounting holes provided. (See outline drawing page 8).

The power supply lead to the anode should be connected via one of the mounting holes.

## HANDLING, STORAGE, MOUNTING AND OPERATIONAL CHECKS (cont'd)

## Operational checks

Excessive v.s.w.r. and/or current values may lead to moding of the magnetron which can be detected by displaying the  $V_a/i_a(\text{pk})$  characteristic of the magnetron on an oscilloscope. This should be done for various load conditions and should be part of production line inspection and of field inspection before and after magnetron replacement.

For x-y display on a service oscilloscope the anode voltage can be sampled from a voltage divider chain connected between earth and the cathode connector, and the anode current from a sampling resistor of a few ohms which may be permanently connected to the earth terminal of the high voltage supply unit.

The normal characteristic should be a fairly straight loop. The appearance of a second loop or parts thereof showing distinctly above the first loop indicates undesired modes of oscillation that can rapidly lead to failure of the magnetron.

Operating conditions including v.s.w.r. must be checked at once and the magnetron replaced if under the correct conditions moding still occurs. The mean anode current may be measured directly across the sampling resistor.

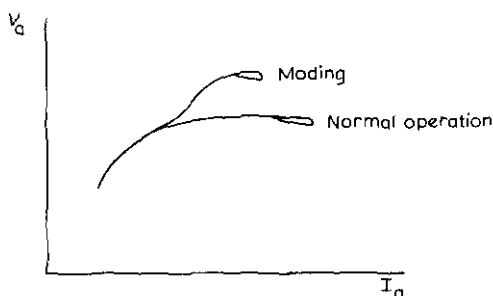

X-Y Display of magnetron characteristic

# OUTLINE DRAWING

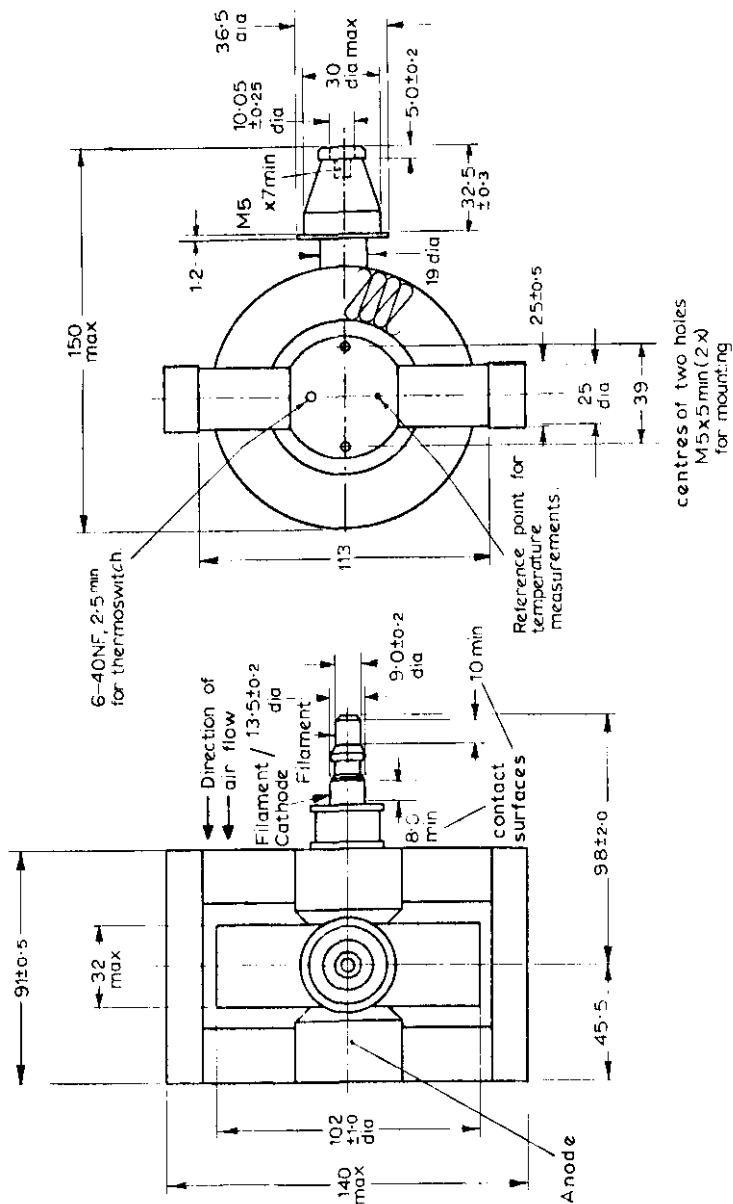

## MILLIMETRE TO INCH CONVERSION TABLE FOR OUTLINE DRAWING

Millimetres	Inches	
1.2	0.047	
5.0 ± 0.2	0.197 ± 0.007	
8.0	0.315	min
9.0 ± 0.2	0.354 ± 0.007	dia
10	0.394	min
10.05 ± 0.25	0.396 ± 0.009	
13.5 ± 0.2	0.531 ± 0.007	dia
19	0.748	dia
25	0.98	dia
25 ± 0.5	0.984 ± 0.19	
30	1.18	max
32	1.26	max
32.5 ± 0.3	1.280 ± 0.01	
36.5	1.43	
39	1.53	
45.5	1.79	
62.2 ± 0.6	2.450 ± 0.023	
91 ± 0.5	3.583 ± 0.19	
98 ± 2.0	3.858 ± 0.07	
102 ± 1.0	4.016 ± 0.03	dia
113	4.45	
140	5.511	max
150	5.905	max

## ACCESSORIES

Inch dimensions given in conversion tables below are derived from original millimetre dimensions

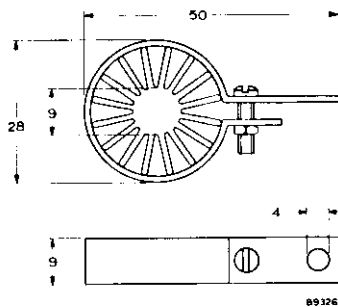
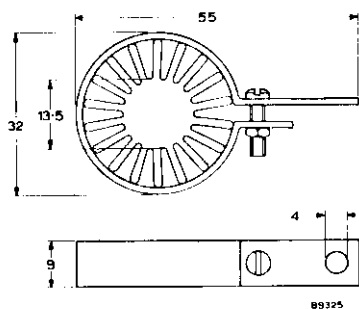

**Filament/cathode connector**  
55324

Millimetres	Inches
4 dia	0.16 dia
9	0.35
13.5 dia	0.53 dia
32 dia	1.26 dia
55	2.16

**Filament connector**  
55323

Millimetres	Inches
4 dia	0.16 dia
9	0.35
9 dia	0.35 dia
28 dia	1.10 dia
50	1.97

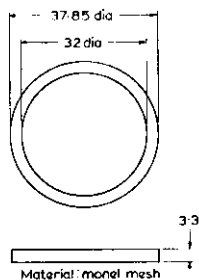

**R. F. gasket**  
S-330109

Millimetres	Inches
3.3	0.13
32 dia	1.26 dia
37.85 dia	1.5 dia

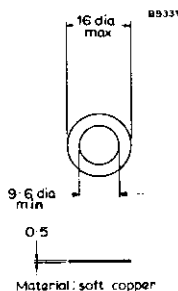

**Washer**  
55328

Millimetres	Inches
0.5	0.02
9.6 dia min	0.38 dia min
16 dia max	0.63 dia max

## ACCESSORIES (cont'd)

Inch dimensions given in conversion tables below are derived from original millimetre dimensions

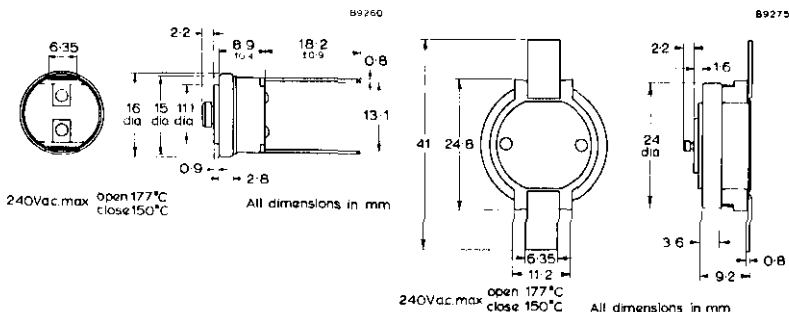

Thermoswitch 4.5A max  
S-32997

Thermoswitch 25A max  
S-330923

Millimetres	Inches	Millimetres	Inches
0.8	0.031	0.8	0.031
0.9	0.035	1.6	0.063
2.2	0.086	2.2	0.086
2.8	0.110	3.6	0.142
6.35	0.25	6.35	0.25
8.9 ± 0.4	0.350 ± 0.015	9.2	0.362
11.1 dia	0.437 dia	11.2	0.441
13.1	0.515	24 dia	0.94 dia
15 dia	0.59 dia	24.8	0.976
16 dia	0.63 dia	41	1.61
18.2 ± 0.9	0.716 ± 0.035		

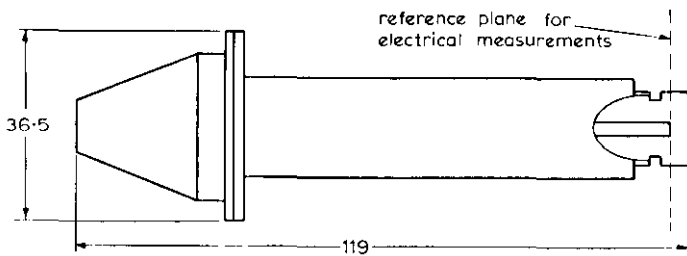

Coupling adaptor  
55336

Millimetres	Inches
36.5	1.43
119	4.68

ACCESSORIES (cont'd)

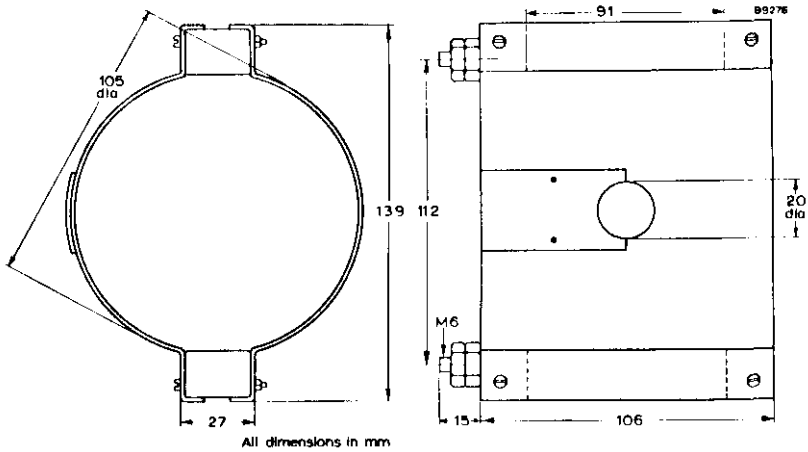

Air inlet duct

Inch dimensions given in conversion table below are derived from original millimetre dimensions

Millimetres	Inches
15	0.59
20 dia	0.79 dia
27	1.06
91	3.58
105 dia	4.13 dia
106	4.17
112	4.41
139	5.47

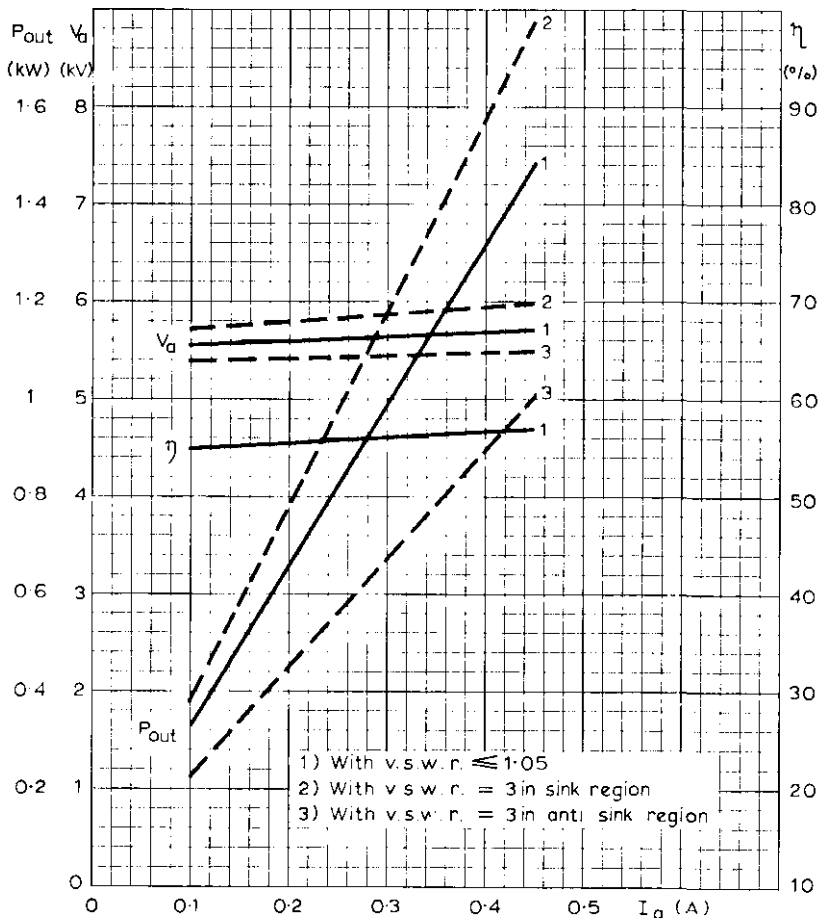

OUTPUT POWER, ANODE VOLTAGE AND EFFICIENCY  
PLOTTED AGAINST ANODE CURRENT

### RIEKE DIAGRAM

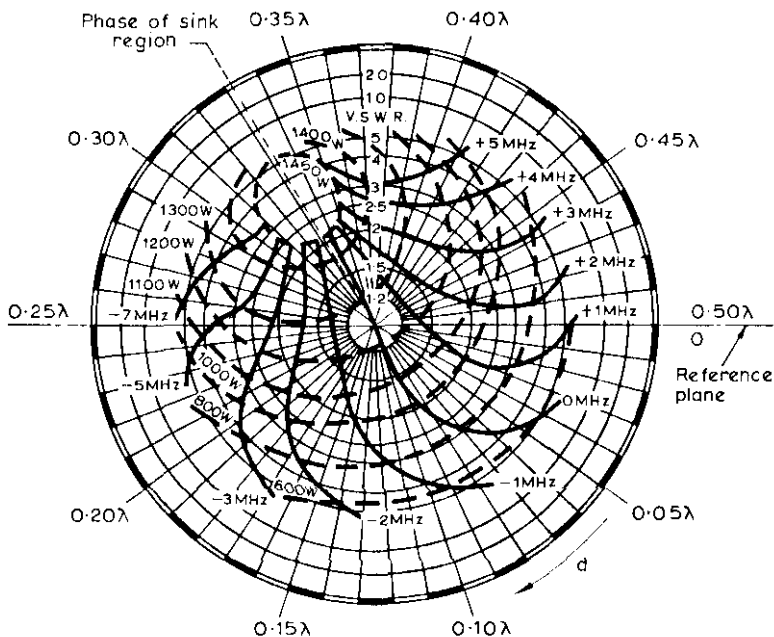

Mean anode current  $I_a = 380\text{mA}$

Frequency  $f_0 = 2.45\text{GHz}$

--- = Output power

— = Frequency pulling

$d$  = distance of voltage standing wave minimum from reference plane for electrical measurement (using coupling adaptor 55336) towards load.

Constant air cooling