

# Quick Reference Chart for Half-Wave Power Rectifiers

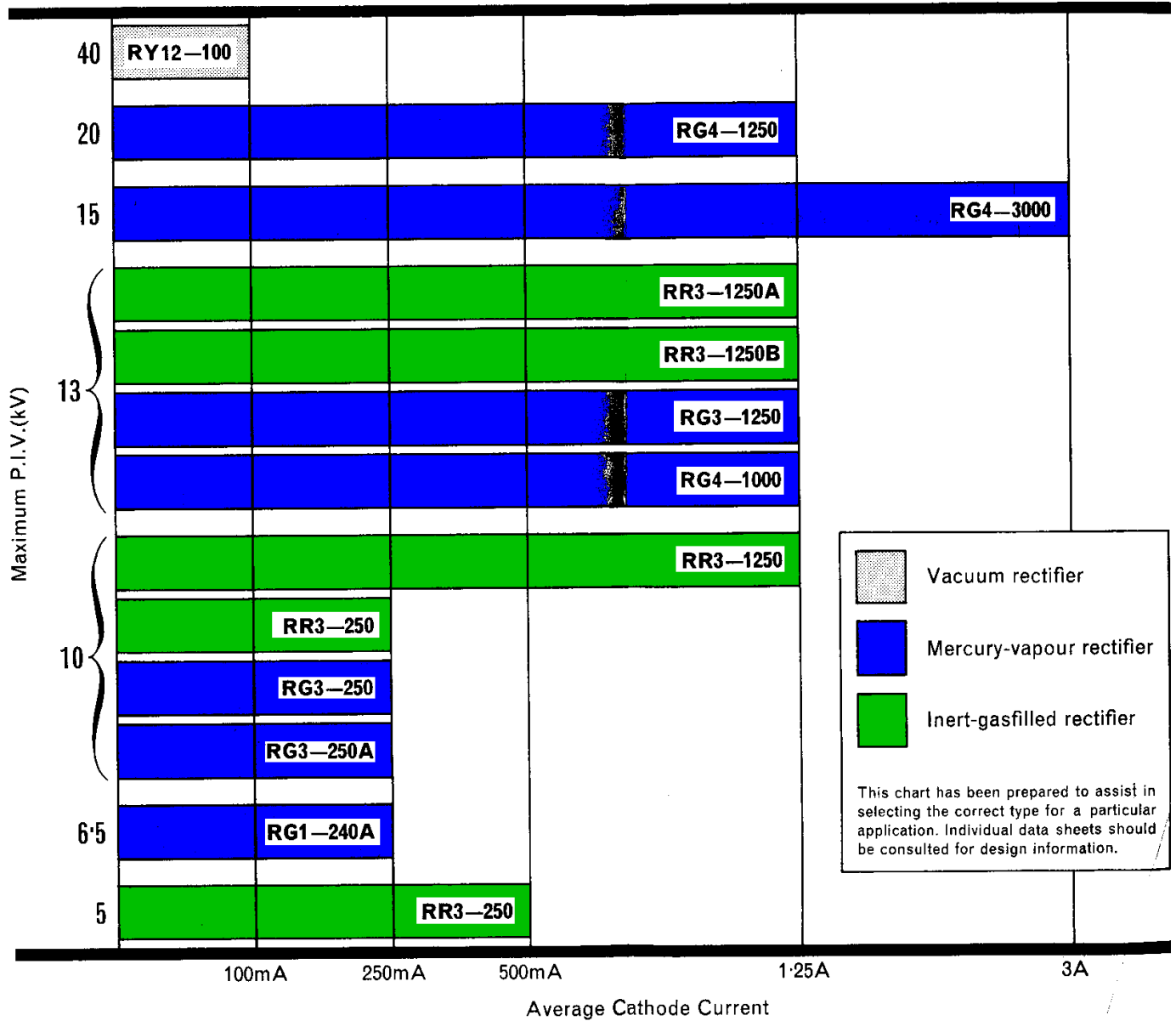

*The following recommendations should be interpreted in conjunction with British Standard Code of Practice No. CP1005: Parts 1 and 2: 1954, 'The Use of Electronic Valves', upon which these notes have, in part, been based.*

### LIMITING VALUES

The operating limits quoted on data sheets for individual values should on no account be exceeded. Two methods of specifying limiting values are used, the 'absolute' and 'design centre' systems, and these should be interpreted as follows:—

#### *Absolute Ratings*

The equipment designer must ensure that these ratings are never exceeded and in arriving at the actual valve operating conditions such variations as mains fluctuations, component tolerances and switching surges must be taken into account.

#### *Design Centre Ratings*

With a set of nominal valves inserted in an equipment connected to the highest permitted nominal supply voltage within a given tapping range, and in which all components have their nominal value, the valve operating conditions may at no time exceed the published maximum design centre value.

The phrase 'at no time' in the above paragraph means that increases in the valve working conditions, due to operating changes in equipment (e.g. switching, etc.), should be taken into account by the equipment designer. Mains voltage variations (of up to  $\pm 6\%$ ) are allowed for in the valve ratings, provided good practice is followed in the design of the equipment.

### FILAMENT OR HEATER SUPPLY

For satisfactory operation the filament or heater voltage of a rectifier should be set within  $\pm 2.5\%$  of the nominal value. Temporary mains fluctuations up to  $\pm 6\%$  are permissible.

To ensure maximum life from a directly heated valve the filament supply should be  $90^\circ \pm 30^\circ$  out of phase with the anode supply unless otherwise specified.

### VALVE TEMPERATURE LIMITATIONS

The ratings published for Mullard mercury vapour rectifiers apply only when they are operated within the limits stated for the temperature of the condensed mercury.

## GENERAL OPERATIONAL RECOMMENDATIONS

GAS-FILLED  
RECTIFIERS

---

With the filament or heater voltage applied, the time required to reach the minimum permissible condensed mercury temperature is a function of the ambient temperature and can be determined from the heating and cooling characteristic. Thus a direct measurement of the condensed mercury temperature, although desirable, is not essential.

Ideally, no cathode current should be drawn until the filament or heater supply has been on for this time, but in practice little damage is done if the current is drawn when the condensed mercury temperature is within 7°C of the minimum permissible value. Thus with normal usage, where the valve is started only two or three times per day, an adequate life can still be obtained with a reduced heating time. The ambient conditions, however, must be such that the minimum permissible condensed mercury temperature is eventually reached and in any case the heating time must not be less than the specified minimum cathode heating time.

With rare-gas rectifiers ambient temperature limitations are given and in general it is only necessary to employ the minimum cathode heating time before switching on.

It is necessary to provide adequate ventilation around the valve so that the maximum ambient or condensed mercury temperature is never exceeded for all conditions of loading. This avoids the danger of arc-back.

Whenever it may be necessary to check the condensed mercury temperature of rectifiers the following procedure is recommended. A temperature indicator of low thermal capacity, such as a fine-wire thermocouple, should be attached to the valve at the mercury condensation point by the minimum amount of adhesive.

Care should be taken to ensure that other conditions of operation, such as load current, ambient temperature of the air outside the equipment, and the ventilation remain unchanged during the measurement.

### CURRENT RATINGS

For each rating of maximum average current, a maximum averaging time is quoted. This is to ensure that an anode current greater than the maximum permissible average value is not drawn for such a length of time as would give rise to an excessive temperature within the valve. For periods less than the maximum averaging time it is permissible to draw average currents greater than the maximum rated value provided that the product of this current and the time does not exceed the product of the maximum rated average current



and the maximum averaging time. When more than one value of peak current is quoted depending upon the frequency of operation, this must be taken into consideration.

#### SHORT CIRCUIT PROTECTION

The figure given on each data sheet for maximum surge fault protection cathode current is intended as a guide to equipment designers.

---

---

#### POWER SUPPLY FREQUENCY LIMITATIONS

Unless otherwise stated, the maximum peak inverse voltage quoted for each valve is that permissible at a maximum supply frequency of 150c/s.

#### PARALLEL OPERATION OF RECTIFIERS

Because individual rectifiers may have slightly different striking voltages two or more valves must not be connected directly in parallel. An alternative arrangement must be adopted if a higher current output is required. Information on suitable methods will be supplied on request.

#### SMOOTHING CIRCUITS

In order to limit the peak cathode current in a rectifier it is necessary that a choke, having the specified minimum inductance, should precede the first smoothing capacitor. Appropriate values for L and C for full load conditions are given on each valve data sheet. In some rectifier circuits however, the value of the inductance may be considerably reduced if the initial surge of current is further limited by employing a starting resistor in series with the primary of the transformer or the first capacitor.

When load currents appreciably lower than those shown are to be taken, the use of filter components of the values given may result in poor regulation. An improvement can be obtained by increasing the inductance of the choke inversely as the load current, i.e., at half

## GENERAL OPERATIONAL RECOMMENDATIONS

GAS-FILLED  
RECTIFIERS

---

load the inductance should be doubled. To ensure good voltage regulation on fluctuating loads, the value of capacitance should be suitable for the maximum current to be taken and the inductance should be large enough to give uninterrupted current at minimum load.

The output voltages quoted on the data sheets refer to ideal conditions and in practice allowance must be made for voltage losses in the valve, choke and transformer. When rectifier circuits are designed to provide maximum output voltage at a specified load, the permissible peak inverse voltage will be exceeded if the load current is decreased.

The single-stage filter specified will not always give sufficient smoothing; this may be improved by increasing inductance or by adding a further stage to the filter. The initial choke and capacitor must not resonate at the supply or ripple frequencies.

The filter circuit values given in the tables are calculated for a supply frequency of 50c/s and will not necessarily be suitable for any other frequency.

Users are invited to apply for detailed proposals to meet individual requirements.

### SCREENING AND R.F. FILTER CIRCUITS

(a) In order to prevent spurious ionisation of the gas or mercury vapour (and consequent flash-over) due to strong r.f. fields, it may be necessary to enclose the rectifiers in a separate screening box. For the same reason r.f. filters should be used to prevent high-frequency current circulating in the rectifier elements via the wiring.

(b) High-frequency disturbances, usually due to oscillation in the transformer windings, are often produced by gaseous rectifiers, and may cause interference in apparatus situated near the rectifier unit. Small r.f. chokes or resistors in the anode leads will generally reduce the interference, and screening as recommended in paragraph (a) above may also be adopted, with r.f. filters in all leads emerging from the screen.

### INSTALLATION

Mercury vapour rectifiers should always be mounted vertically with the cathode connections at the lower end. When a mercury vapour rectifier is first installed, and before it is put into service, it should be run for at least half an hour at its normal filament or heater

GAS-FILLED  
RECTIFIERS

**GENERAL OPERATIONAL  
RECOMMENDATIONS**

---

voltage but without any electrode voltages applied, in order to vaporise any mercury which may have been deposited upon the electrode assembly during transit. This precaution should also be taken before putting into service a mercury vapour valve which has been out of use for any considerable time.

**CIRCUITS**

The four circuits shown in the accompanying diagrams are those referred to in the data sheets and cover all normal requirements. In these circuits, fuses and r.f. stopper resistors are not shown.



**GENERAL OPERATIONAL  
RECOMMENDATIONS**

**GAS-FILLED  
RECTIFIERS**

in these circuits

- $V_{out}$  = Output voltage on load
- $V_{r.m.s.}$  = Voltage of each section of transformer secondary
- P.I.V. = Maximum permissible inverse peak voltage

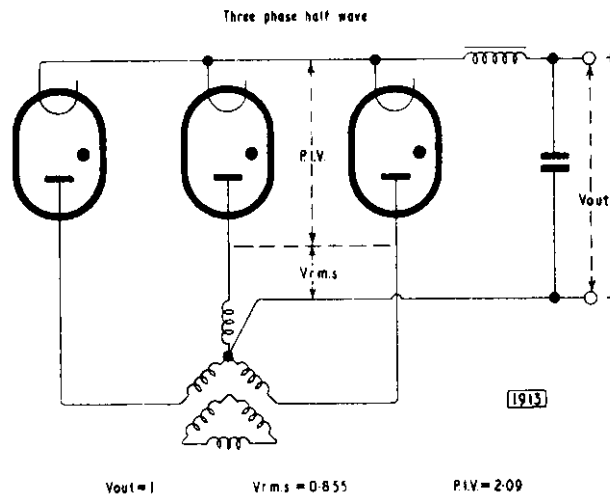
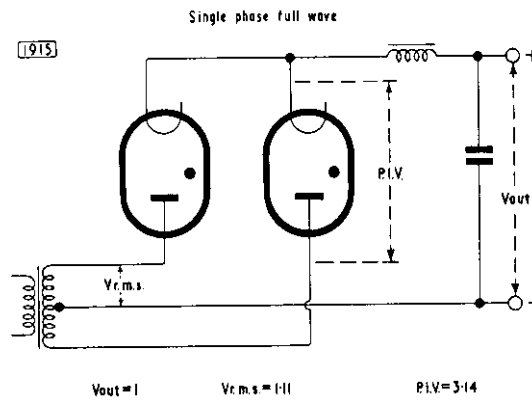

GAS-FILLED  
RECTIFIERS

GENERAL OPERATIONAL  
RECOMMENDATIONS

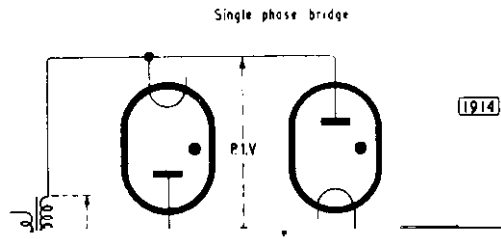

$V_{out} = I$        $V_{r.m.s.} = HI$        $P.P.V. = 1.57$

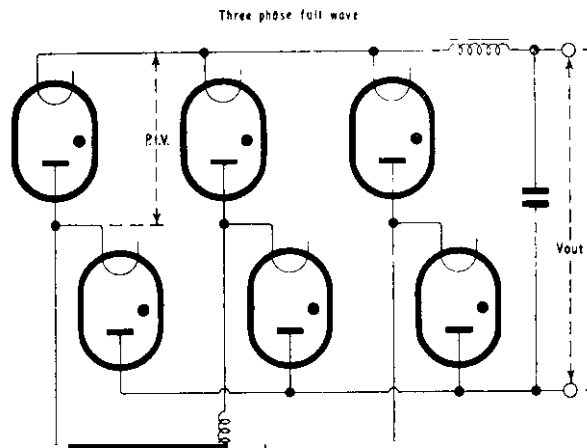

( )

( )

( )

( )



## HALF-WAVE RECTIFIER

# RG I-240A

Voltage: 6.5kV peak inverse.  
Current: 250mA maximum average  
Application: Power rectification.  
Gas filling: Mercury vapour.

This data should be read in conjunction with GENERAL OPERATIONAL RECOMMENDATIONS – GAS-FILLED RECTIFIERS which precede this section of the handbook.

### ABSOLUTE MAXIMUM RATINGS

It is important that these ratings are never exceeded and such variations as mains fluctuations, component tolerances and switching surges must be taken into consideration in arriving at the actual operating conditions.

Maximum peak inverse anode voltage	6.5	kV
Condensed-mercury temperature		
Maximum	65	°C
Minimum	25	°C
Maximum cathode current		
Average	250	mA
Peak	1.25	A
Surge (fault protection, maximum duration = 0.1s)	25	A
Maximum operating frequency	150	c/s

### CHARACTERISTICS

Filament voltage	4.0	V
Nominal filament current at 4.0V	2.7	A
Nominal anode voltage drop	12	V
Nominal ignition voltage (see note 1)	12	V
Equilibrium condensed-mercury temperature rise above ambient	See note 2	
Heating time	See note 3	
Net weight (approx.)	{ 2.6 75	oz g
Weight of valve in carton (approx.)	{ 8.1 230	oz g
Nominal dimensions of carton	{ 8.5 × 3.5 × 3.5 220 × 90 × 90	in mm

# RG1-240A

## HALF-WAVE RECTIFIER

### FULL LOAD OPERATING CONDITIONS

These figures are based upon the absolute maximum ratings of the valve and no account has been taken of mains variations or transformer, valve and choke losses. In practice, due consideration must be given to these factors.

See, also, appropriate sections of 'General Operational Recommendations - Gas-Filled Rectifiers'.

Circuit	No. of valves	Full load d.c. output		Applied a.c. voltage (kV <sub>r.m.s.</sub> )	Initial filter elements	
		(kV)	(mA)		L (H)	C ( $\mu$ F)
Single phase full-wave	2	2.0	500	2.22 (per valve)	7.0	5.0
Single phase bridge	4	4.0	500	4.44	14	2.5
Three phase half-wave	3	2.75	750	2.35 (per phase)	2.5	2.0
Three phase full-wave	6	6.0	750	2.57 (per phase)	5.0	1.0

### OPERATING NOTES

Under normal conditions cathode current may be drawn when the condensed-mercury temperature is approximately within 7°C of the minimum value given. (See appropriate section of 'General Operational Recommendations - Gas-Filled Rectifiers').

HALF-WAVE RECTIFIER

# RG I-240A

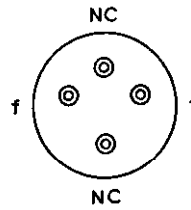
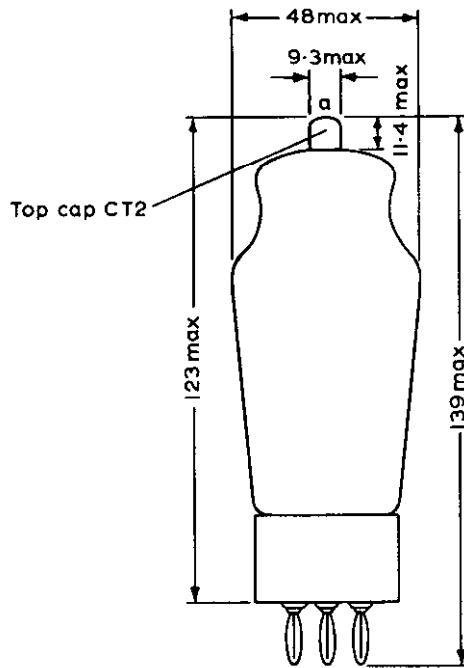

British 4-Pin Base

All dimensions in mm

6709

( )

( )

( )

( )



HALF-WAVE RECTIFIER

**RG3-250**  
**RG3-250A**

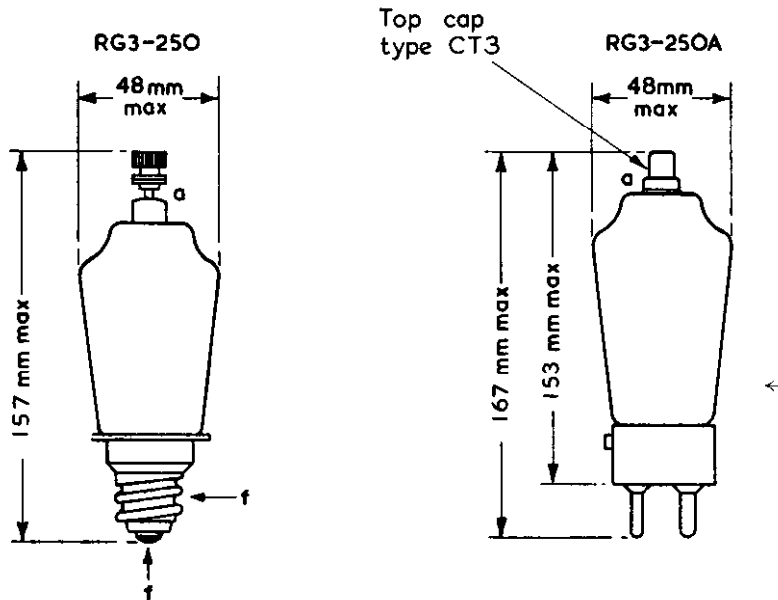

Medium Edison screw base

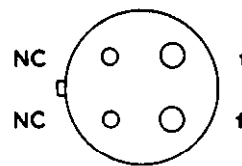

Medium 4-pin base with bayonet catch

7852

# RG3-250 RG3-250A

## HALF-WAVE RECTIFIER

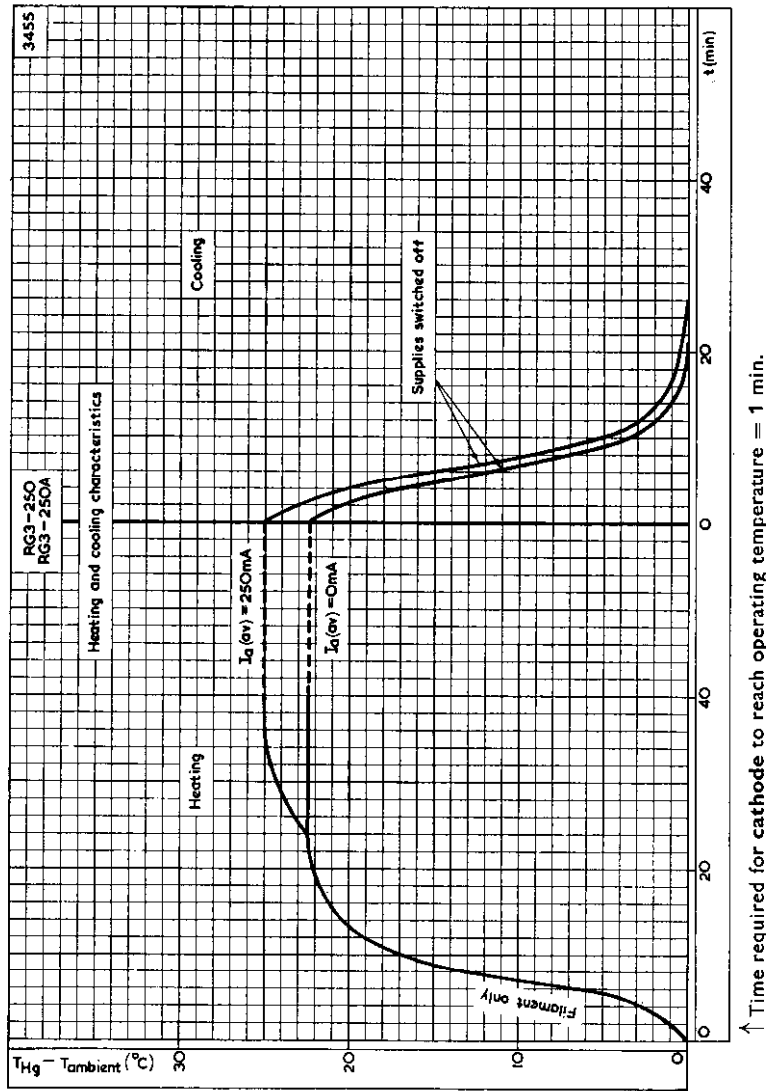

HEATING AND COOLING CHARACTERISTICS. EXCESS TEMPERATURE OVER AMBIENT PLOTTED AGAINST TIME

## HALF-WAVE RECTIFIER

# RG4-I250

### QUICK REFERENCE DATA (maximum values)

*Mercury vapour half-wave rectifier for power rectification.*

P.I.V. max.	20	kV
$I_{k(av)}$ max.	1.25	A

This data should be read in conjunction with GENERAL OPERATIONAL RECOMMENDATIONS—GAS-FILLED RECTIFIERS which precede this section of the handbook.

### ABSOLUTE MAXIMUM RATINGS

It is important that these ratings are never exceeded and such variations as mains fluctuations, component tolerances and switching surges must be taken into consideration in arriving at the actual operating conditions.

Maximum peak inverse anode voltage (see note 1)	20	10	kV
Condensed mercury temperature (see note 1)			
Maximum	40	55	°C
Minimum	20	20	°C
Maximum cathode current			
Average (maximum averaging time = 15s)		1.25	A
Peak		5.0	A
Surge (fault protection, maximum duration = 0.1s)		25	A
Filament voltage			
Maximum		4.1	V
Minimum		3.9	V
Maximum operating frequency		150	c/s
Valve heating time	See note 3		
Minimum cathode heating time (see note 4)		1	min

### CHARACTERISTICS

Filament voltage	4.0	V
Nominal filament current at 4.0V	11	A
Nominal anode voltage drop	12	V
Nominal ignition voltage	See note 2	
Equilibrium condensed mercury temperature rise above ambient		
At full load (approx.)	16	°C
At no load (approx.)	14	°C
Net weight (approx.)	{ 10.5	oz
	{ 300	g
Weight of valve in carton (approx.)	{ 28	oz
	{ 800	g
Nominal dimensions of carton	{ 12 × 5.5 × 5.5	in
	{ 300 × 140 × 140	mm

# RG4-1250

## HALF-WAVE RECTIFIER

### FULL LOAD OPERATING CONDITIONS

These figures are based upon the absolute maximum ratings of the valve and no account has been taken of mains variations or transformer, valve and choke losses. In practice, due consideration must be given to these factors. See, also, appropriate sections of 'General Operational Recommendations—Gas-Filled Rectifiers'.

Circuit	No. of valves	Full load d.c. output		Applied a.c. voltage (kV <sub>r.m.s.</sub> ) (per valve)	Initial filter elements	
		(kV)	(A)		(H)	(μF)
Single phase full-wave	2	6.3	2.5	7.0	4.0	5.0
Single phase bridge	4	12.6	2.5	14	8.0	2.5
Three phase half-wave	3	8.2* (9.5)	3.75	7.0* (8.1) (per phase)	3.0	2.0
Three phase full-wave	6	19.1	3.75	8.1 (per phase)	4.0	1.0

\*These figures take into account the increase in peak inverse voltage which occurs if the power supply is lightly loaded. For operation with a constant load the maximum voltages are the values shown in brackets.

### OPERATING NOTES

1. The maximum condensed-mercury temperature rating for intermediate anode voltages may be determined by linear interpolation.

(see page C2 and appropriate section of 'General Operational Recommendations—Gas-Filled Rectifiers').

4. Under no circumstances should the anode voltage be applied until at least one minute after the application of the filament voltage.

HALF-WAVE RECTIFIER

# RG4-1250

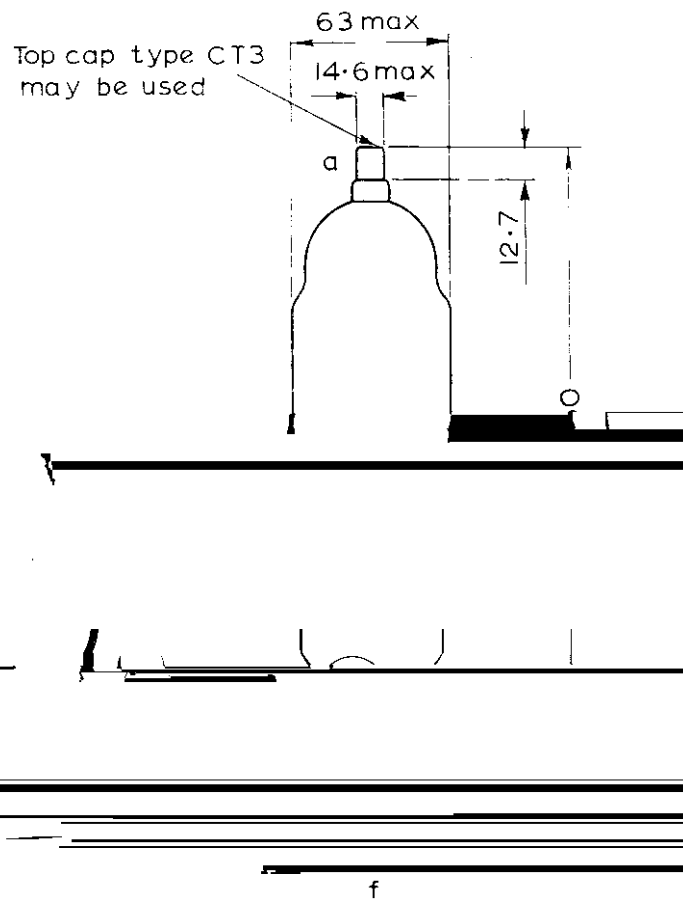

All dimensions in mm

8707

( )

( )

(

(



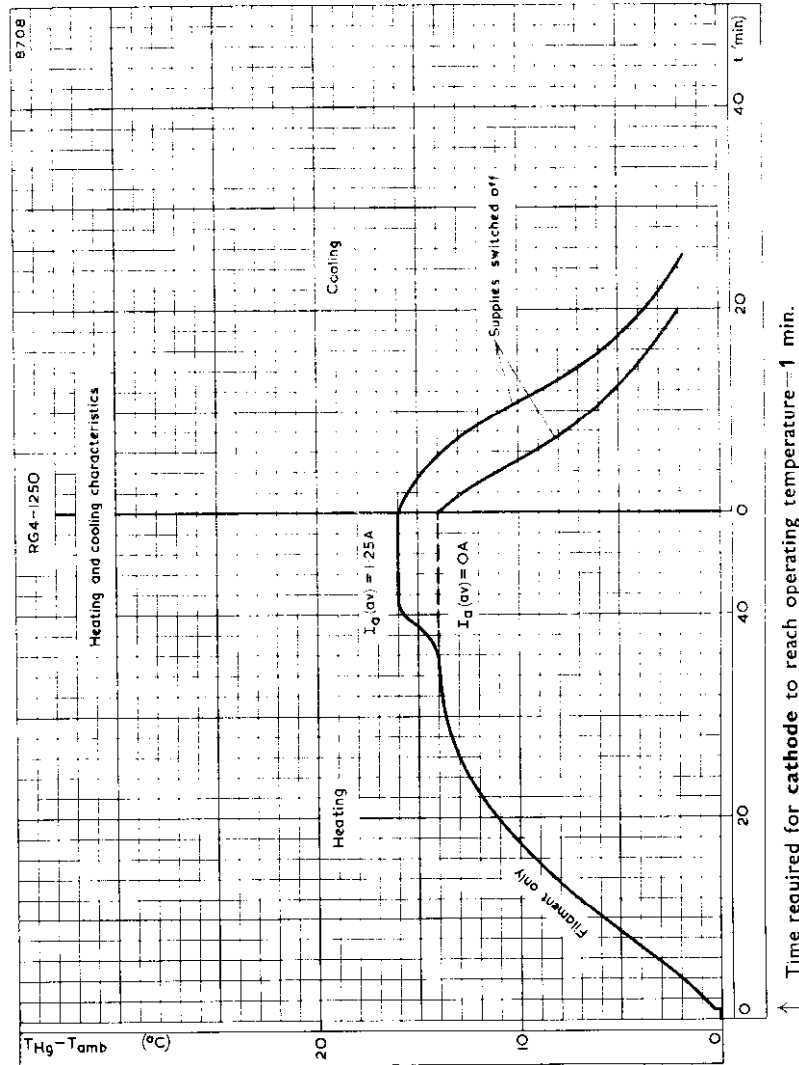

HEATING AND COOLING CHARACTERISTIC. EXCESS TEMPERATURE OVER AMBIENT PLOTTED AGAINST TIME

# RG4-1250

HALF-WAVE RECTIFIER

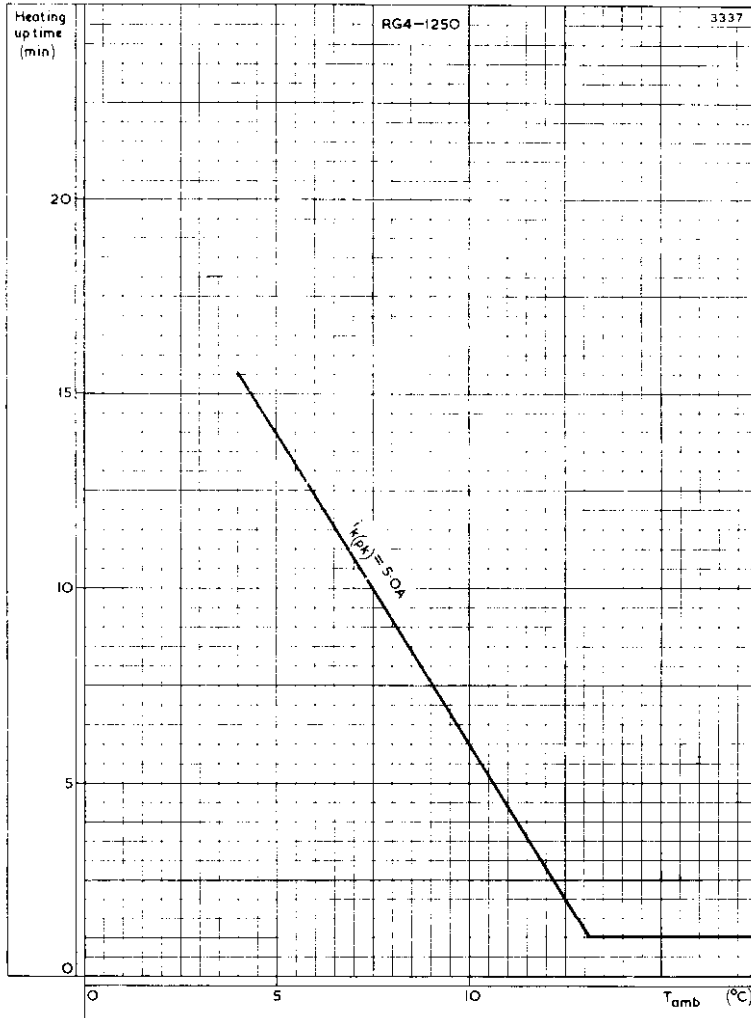

TOTAL HEATING-UP TIME PLOTTED AGAINST AMBIENT TEMPERATURE



## HALF-WAVE RECTIFIER

# RG4-3000

Mercury vapour half-wave rectifier  
for use in high voltage rectifier circuits.

This data should be read in conjunction with GENERAL OPERATIONAL RECOMMENDATIONS — GAS-FILLED RECTIFIERS, preceding this section of the handbook.

### LIMITING VALUES (absolute ratings, not design centre)

It is important that these limits are never exceeded and such variations as mains fluctuations, component tolerances and switching surges must be taken into consideration in arriving at actual valve operating conditions.

*Max. peak inverse anode voltage	2.5	10	15	kV
*Condensed mercury temperature limits	25 to 75	25 to 60	25 to 55	°C
Max. cathode current				
Peak	20	12	12	A
Average (max. averaging time 10s)	5.0	3.0	3.0	A
Surge (fault protection max. duration 0.1s)	200	120	120	A
Max. operating frequency	150	150	150	c/s

\*Max. condensed mercury temperature rating for intermediate anode voltages may be determined by linear interpolation.

### CHARACTERISTICS

#### Electrical

Filament voltage	5.0	V
Average filament current at 5.0V	11.5	A
Anode voltage drop	12	V

#### Mechanical

Equilibrium condensed mercury temperature rise above ambient		
At full load (approx.)	21	°C
At no load (approx.)	19	°C
Mounting position	Vertical, base down	
Max. net weight	{ 450 15.5	{ g oz
Weight of rectifier in packing	{ 1.8 63	{ kg oz
Dimensions of packing	{ 8.5 × 8.5 × 17.25 216 × 216 × 438	{ in mm

# RG4-3000

## HALF-WAVE RECTIFIER

### FULL LOAD OPERATING CONDITIONS

For peak inverse anode voltage of 15kV and a peak cathode current of 12A.

Circuit	No. of valves	Full load d.c. output		Applied a.c. voltage (kV <sub>r.m.s.</sub> )	Initial filter elements	
		(kV)	(A)		L min. (H)	C max. (μF)
Single phase full-wave	2	4.8	6.0	5.3 (per valve)	1.5	16
Single phase bridge	4	9.6	6.0	10.6 (total)	3	8
Three phase half-wave	3	6.2* (7.2)	9.0	5.3* (6.1) (per phase)	1	8
Three phase full-wave	6	14.4	9.0	6.1 (per phase)	2	4

For peak inverse anode voltage of 2.5kV and a peak cathode current of 20A.

Circuit	No. of valves	Full load d.c. output		Applied a.c. voltage (kV <sub>r.m.s.</sub> )	Initial filter elements	
		(kV)	(A)		L min. (H)	C max. (μF)
Single phase full-wave	2	0.79	10	0.88 (per valve)	0.2	100
Single phase bridge	4	1.58	10	1.76 (total)	0.4	50
Three phase half-wave	3	1.03* (1.19)	15	0.88* (1.02) (per phase)	0.1	50
Three phase full-wave	6	2.38	15	1.02 (per phase)	0.2	25

\*These figures take into account the increase in peak inverse voltage which occurs if the power supply is lightly loaded. For operation with a constant load the voltages may be increased to the value shown in brackets.

### HEATING UP TIME

The preferred minimum value of the total valve heating up time can be obtained from the curve on page C2. This shows how the condensed mercury temperature rises above the ambient temperature from the instant of switching on the filament supply.

Minimum cathode heating time 1 min



# RG4-3000

HALF-WAVE RECTIFIER

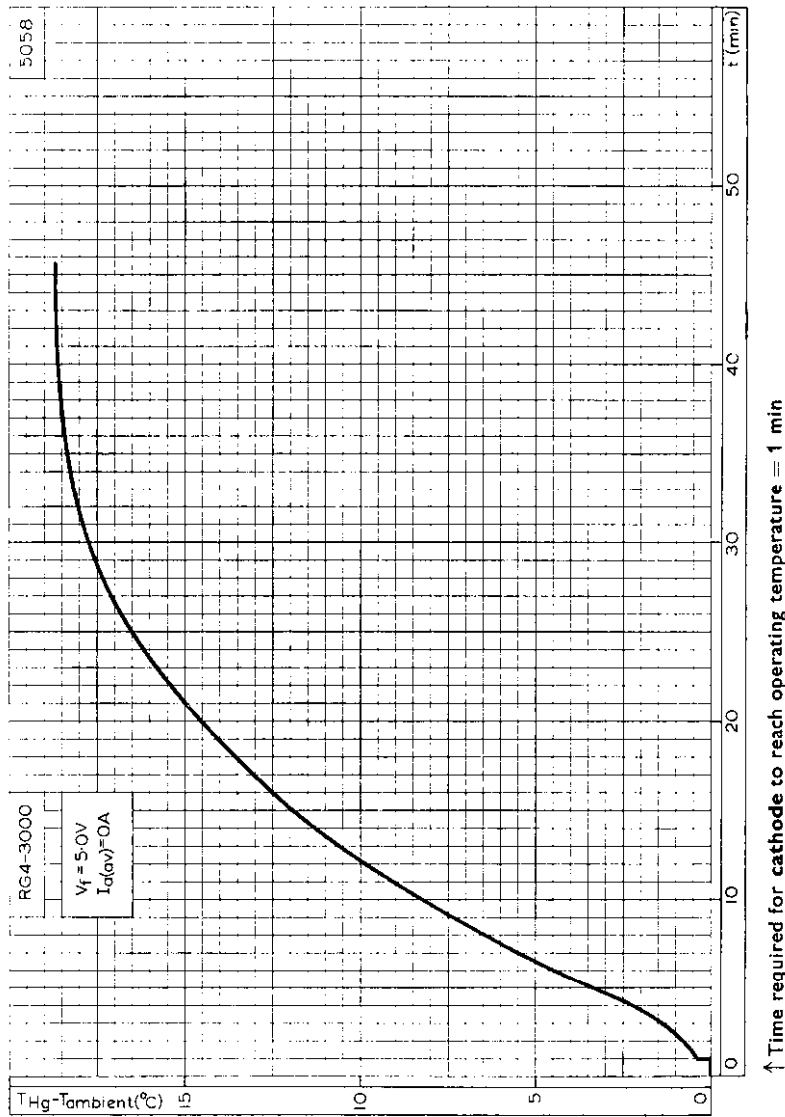

HEATING CHARACTERISTICS. EXCESS TEMPERATURE OVER AMBIENT PLOTTED AGAINST TIME

HALF-WAVE RECTIFIER

# RG4-3000

3691

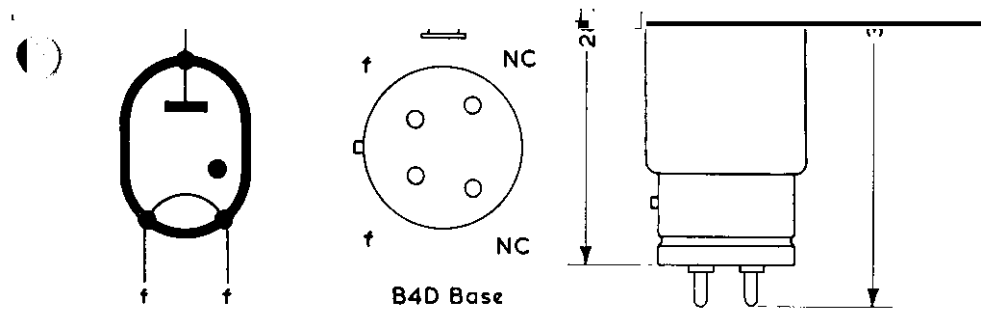
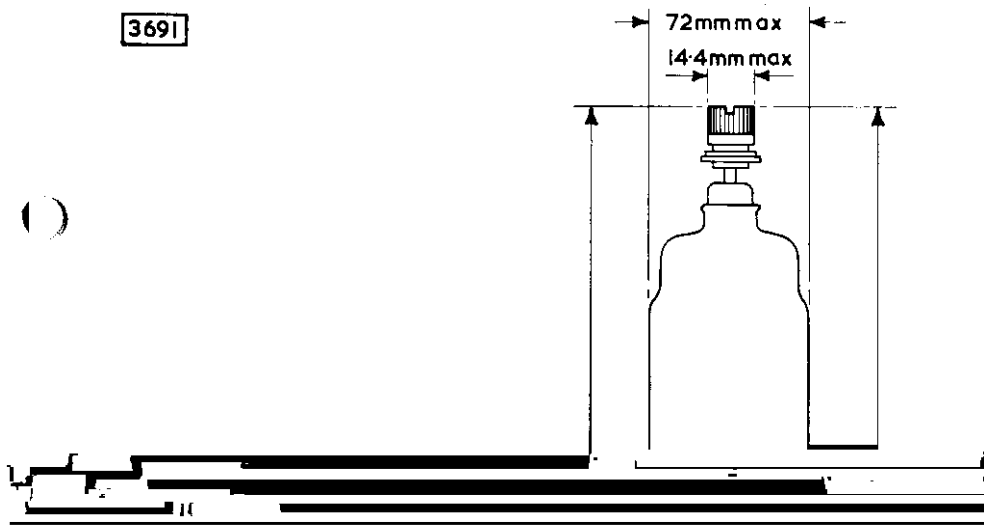

# RR3-250

## HALF-WAVE RECTIFIER

*Inert gas-filled half-wave rectifier for use in high voltage rectifier circuits.*

### FULL LOAD OPERATING CONDITIONS (cont.)

Circuit	No. of valves	P.I.V. (kV)	Full load		Applied a.c. volts (kV <sub>r.m.s.</sub> )	Initial filter elements	
			d.c. output (kV)	(A)		L min. (H)	C max. (μF)
Three phase half-wave	3	10	4.1* (4.7)	0.75	3.5* (4.1) (per phase)	6.0	1.0
		5.0	2.0* (2.3)	1.5	1.7* (2.0) (per phase)	1.5	4.0
Three phase full-wave	6	10	9.5	0.75	4.1 (per phase)	10	0.5
		5.0	4.7	1.5	2.0 (per phase)	2.5	2.0

\*These figures take into account the increase in peak inverse voltage which occurs if the power supply is lightly loaded. For operation with a constant load the voltages may be increased to the value shown in brackets.

### CIRCUIT NOTES

When quadrature operation is used the filament voltage (pin 4 with respect to pin 1) should be crossing zero from positive to negative when the anode voltage is at the peak of the positive half cycle.

When quadrature operation is not practicable filament pin 4 should be positive when the anode is positive.

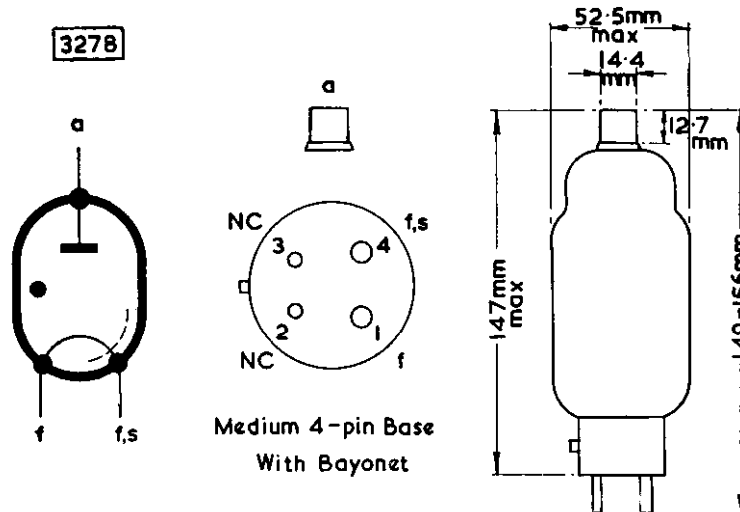

## HALF-WAVE RECTIFIER

# RR3-250

*Inert gas-filled half-wave rectifier for use in high voltage rectifier circuits.*

### LIMITING VALUES (Absolute ratings)

It is important that these limits are never exceeded and such variations as mains fluctuations, component tolerances and switching surges must be taken into consideration in arriving at actual valve operating conditions.

Max. peak inverse anode voltage	5.0	10	kV
Max. cathode current			
Peak	2.0	1.0	A
Average (max. averaging time 15s)	500	250	mA
Surge (fault protection max. duration 0.1s)	20	20	A
Min. valve heating time	10	10	s
Max. supply frequency	500	150	c/s
Ambient temperature limits	-55 to +75	-55 to +75	°C

### CHARACTERISTICS

#### Electrical

Filament voltage	2.5	V
Average filament current at 2.5V	5.0	A
Anode voltage drop ( $I_a = 500\text{mA}$ )	12	V

#### Mechanical

Type of cooling	Convection
Mounting position	Any
Max. net weight	{ 3.5 oz 100 g

### FULL LOAD OPERATING CONDITIONS

Circuit	No. of valves	P.I.V. (kV)	Full load d.c. output		Applied a.c. volts (kV <sub>r.m.s.</sub> )	Initial filter elements	
			(kV)	(A)		L min. (H)	C max. (μF)
Single phase full-wave	2	{ 10 5.0	3.1	0.5	3.5 (per valve)	10	2.0
			1.5	1.0	1.7 (per valve)	2.5	8.0
Single phase bridge	4	{ 10 5.0	6.3	0.5	7.0 (total)	20	1.0
			3.1	1.0	3.5 (total)	5.0	4.0





## HALF-WAVE RECTIFIER

# RR3-1250

Inert gas-filled half-wave rectifier for use in high voltage rectifier circuits.

This data should be read in conjunction with GENERAL OPERATIONAL RECOMMENDATIONS—GAS FILLED RECTIFIERS, preceding this section of the handbook.

### LIMITING VALUES (absolute ratings)

It is important that these limits are never exceeded and such variations as mains fluctuations, component tolerances and switching surges must be taken into consideration in arriving at actual valve operating conditions.

Max. peak inverse anode voltage	10	kV
Max. cathode current		
Peak	5.0	A
Average (max. averaging time 15s)	1.25	A
Surge (fault protection max. duration 0.1s)	50	A
Min. valve heating time	30	s
Max. operating frequency	150	c/s
Ambient temperature limits	-55 to +70	°C

### CHARACTERISTICS

#### Electrical

Filament voltage	5.0	V
Average filament current at 5.0V	7.0	A
Anode voltage drop ( $I_a = 1.25A$ )	13	V

#### Mechanical

Type of cooling	Convection	
Mounting position	Any	
Max. net weight	{ 8.0	oz
	{ 220	g

### FULL LOAD OPERATING CONDITIONS (for peak inverse voltage of 10kV and peak cathode current of 5.0A)

Circuit	No. of valves	Full load d.c. output		Applied a.c. volts (kV <sub>r.m.s.</sub> )	Initial filter elements	
		(kV)	(A)		Lmin. (H)	C max. (μF)
Single phase full-wave	2	3.1	2.5	3.5 (per valve)	2.0	10
Single phase bridge	4	6.3	2.5	7.0 (total)	4.0	5.0
Three phase half-wave	3	4.1* (4.7)	3.75	3.5* (4.1) (per phase)	1.5	4.0
Three phase	6	9.5	3.75	4.1 (per phase)	2.0	2.5

\*These figures take into account the increase in peak inverse voltage which occurs if the power supply is lightly loaded. For operation with a constant load the voltage may be increased to the value shown in brackets.

# RR3-1250

## HALF-WAVE RECTIFIER

*Inert gas-filled half-wave rectifier for use  
in high voltage rectifier circuits.*

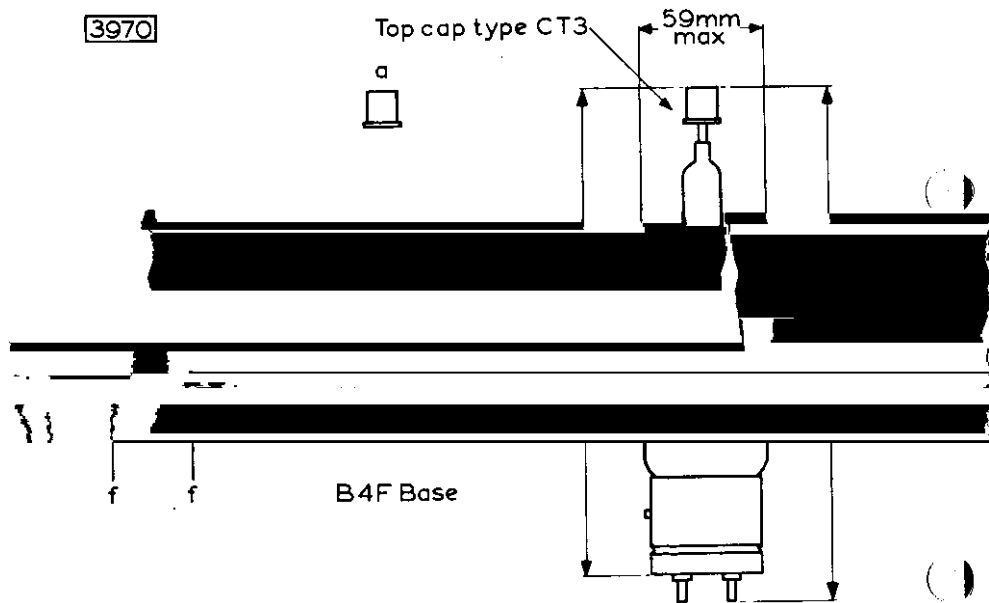

## HALF-WAVE RECTIFIER

# RR3-1250A

*Inert gas-filled half-wave rectifier for use in high voltage rectifier circuits.*

This data should be read in conjunction with GENERAL OPERATIONAL RECOMMENDATIONS—GAS FILLED RECTIFIERS, preceding this section of the handbook.

### LIMITING VALUES (absolute ratings)

It is important that these limits are never exceeded and such variations as mains fluctuations, component tolerances and switching surges must be taken into consideration in arriving at actual valve operating conditions.

Max. peak inverse anode voltage	13	kV
Max. cathode current		
Peak	5.0	A
Average (max. averaging time 15s)	1.25	A
Surge (fault protection max. duration 0.1s)	50	A
Min. valve heating time	30	s
Max. operating frequency	150	c/s
Ambient temperature limits	-55 to +70	°C

### CHARACTERISTICS

#### Electrical

Filament voltage	4.0	V
Average filament current at 4.0V	11	A
Anode voltage drop ( $I_a = 1.25A$ )	13	V

#### Mechanical

Type of cooling	Convection
Mounting position	Any

### FULL LOAD OPERATION CONDITIONS (for peak inverse voltage of 13kV and peak cathode current of 5.0A)

Circuit	No. of valves	Full load d.c. output		Applied a.c. volts ( $kV_{r.m.s.}$ )	Initial filter elements	
		(kV)	(A)		L min. (H)	C max. ( $\mu F$ )
Single phase full-wave	2	4.1	2.5	4.5 (per valve)	2.5	6.0
Single phase bridge	4	8.2	2.5	9.1 (total)	5.0	3.0
Three phase half-wave	3	5.3* (6.2)	3.75	4.5* (5.3) (per phase)	1.5	4.0
Three phase full-wave	6	12.4	3.75	5.3 (per phase)	3.0	2.0

\*These figures take into account the increase in peak inverse voltage which occurs if the power supply is lightly loaded. For operation with a constant load the voltages may be increased to the value shown in brackets.

# RR3-I250A

3971

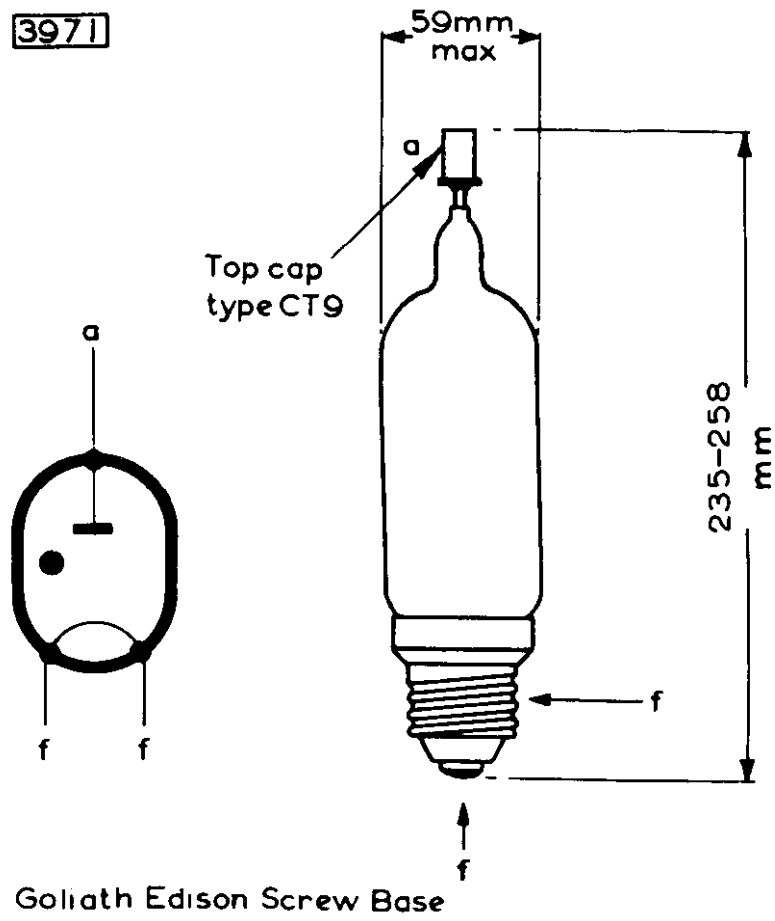



# RR3-1250B

B4616

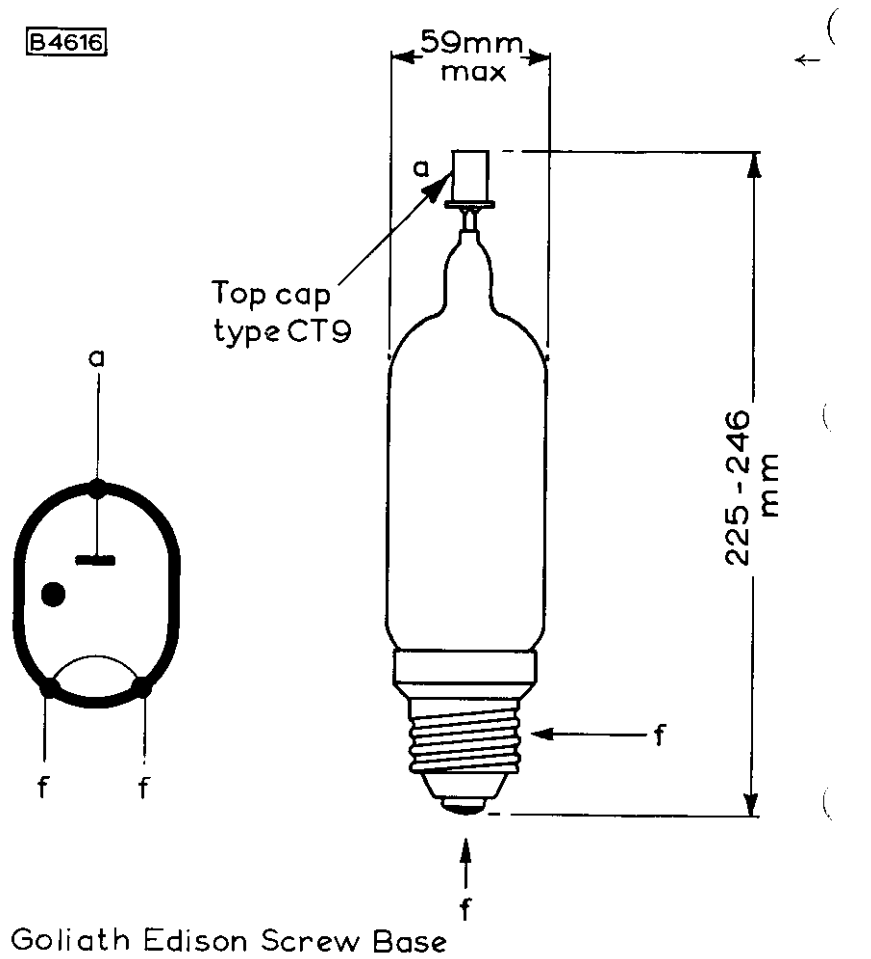

# HALF-WAVE RECTIFIER

# RY12-100

## QUICK REFERENCE DATA (maximum values)

Vacuum half-wave rectifier for use in high voltage rectifier circuits and surge limiting circuits.

P. I. V. max.	40	kV
$I_{k(av)}$ max.	100	mA

FILAMENT thoriated tungsten  
 \* Filament voltage 5.0 ± 5% V

maximum peak inverse anode voltage	40	kV
Maximum anode dissipation	60	W
Maximum cathode current		
Peak	750	mA
Average	100	mA
Maximum temperature of anode seal	225	°C
Limiting service		
Maximum forward anode voltage	12.5	kV
Maximum anode dissipation	75	W

## CHARACTERISTICS

### Electrical

Anode voltage drop ( $I_k = 100\text{mA}$ )	200	V
$C_{a-f}$	1.4	pF

### Mechanical

Cooling	Radiation and convection	
Mounting position	Vertical, base down	
Maximum net weight	90	g
	3.2	oz
Shipping weight	1.06	kg
	36.6	oz



**HEATING UP TIME**

Minimum cathode heating time 5.0 s

**FULL LOAD OPERATING CONDITIONS**

For peak inverse voltage of 40kV

Circuit	No. of valves	Applied a. c. voltage (kV r. m. s. (per valve))	Full load d. c. output capacitor input filter*		Full load d. c. output choke input filter	
			(kV)	(mA)	(kV)	(mA)
Single phase half wave	1	14	17	80	-	-
Single phase full wave	2	14	17	160	12.5	200
Single phase bridge	4	28	34	160	25	200

\*With a capacitor input filter a limiting resistor may be necessary to limit the peak current to within the maximum permissible value.

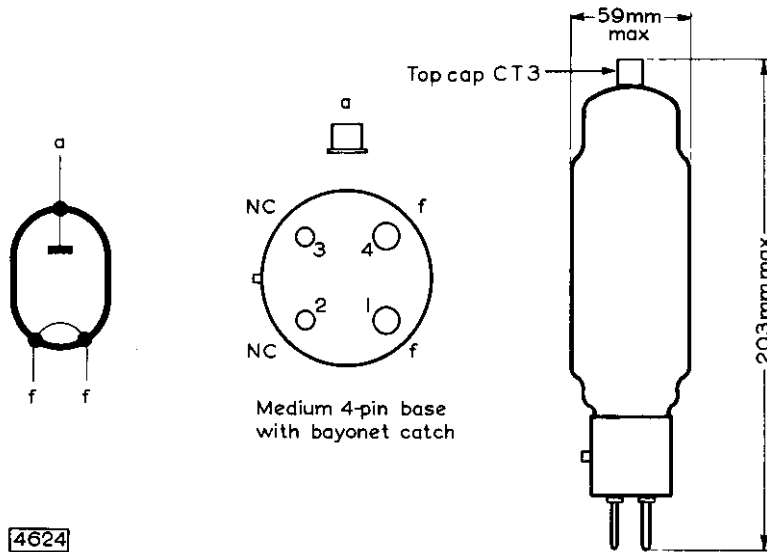

4624

# HALF-WAVE RECTIFIER

# RY12-100

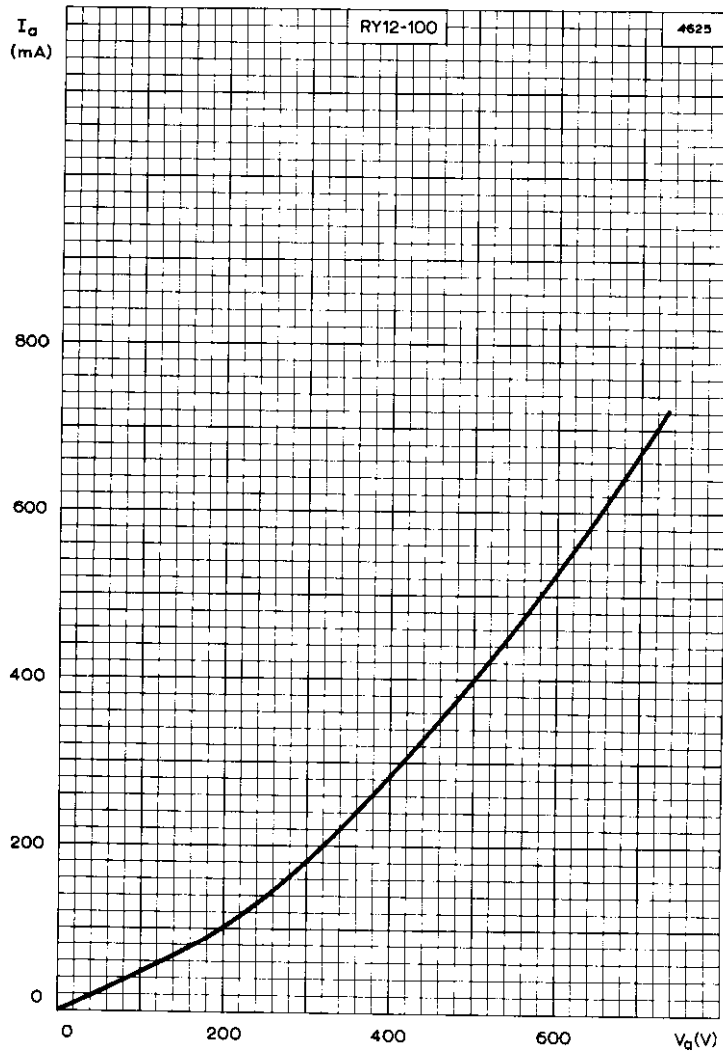

ANODE CURRENT PLOTTED AGAINST ANODE VOLTAGE





(

(

(

