



VOLUME 3A



Microwave Devices and Components

communications magnetrons
industrial magnetrons
klystrons
travelling wave tubes
disc seal triodes
microwave components

Issued by
TECHNICAL INFORMATION DEPARTMENT
MULLARD LIMITED
MULLARD HOUSE, TORRINGTON PLACE, LONDON W.C.1
TELEPHONE: LANGHAM 6633

1. GENERAL

Failure to observe these General Operational Recommendations may seriously reduce the life of a valve and in some instances could result in catastrophic failure.

Any enquiries should be addressed to the Government and Industrial Valve Division, Mullard Limited.

2. CHARACTERISTICS

The published characteristics are based upon averages of readings taken on a representative number of valves.

3. LIMITING VALUES

The limiting values whether maximum or minimum are absolute and the following definition of the absolute system has been based on that agreed by the International Electrotechnical Commission.

3.1. Absolute-maximum rating system

Absolute-maximum ratings are limiting values of operating and environmental conditions applicable to any valve of a specified type as defined by its published data, and should not be exceeded under the worst probable conditions.

These values are chosen by the valve manufacturer to provide acceptable serviceability of the valve, taking no responsibility for equipment variations, environmental variations, and the effects of changes in operating conditions due to variations in the characteristics of the valve under consideration and all other electron devices in the equipment.

The equipment manufacturer should design so that initially and throughout life no absolute-maximum value for the intended service is exceeded with any valve under the worst probable operating conditions with respect to supply voltage variations, equipment component variation, equipment control adjustment, load variations, signal variation, environmental conditions, and variations in characteristics of the valve under consideration and of all other devices in the equipment.

In some instances, such as with very short pulse durations or complex wave trains, it may be permitted to exceed the absolute values, but the desired operating conditions must be agreed with Mullard Limited.

4. TYPICAL OPERATING CONDITIONS

Typical operating conditions are given, some of which may incorporate one or more of the absolute ratings; in such cases the designer should take precautionary steps to ensure that these ratings are never exceeded.

Where several typical operating conditions are given, interpolation for intermediate conditions is generally permitted. There are exceptions to this rule and the operating conditions should be agreed with Mullard Limited.

5. INSTALLATION

Ferrous tools must not be used on permanent magnet valves, as this may cause deterioration in the performance of the valve. Any glass or ceramic insulation supporting the cathode terminal should be carefully cleaned when necessary since pulse current leakage could cause irregular transmission and damage through local heating. In addition the outlet flange must be clean in order to discourage arcing.

6. PRESENTATION OF VALVE DATA

The symbols, component and base references incorporated in the data are in accordance with the following British Standards:—

1409: 1950	Letter symbols for electronic valves.
1991: Part I: 1954	Letter symbols, signs and abbreviations.
530: 1948 (with supplements)	Graphical symbols for telecommunications.
448: 1953	Electronic-valve bases, caps and holders.
204: 1960	Glossary of terms used in telecommunications (including radio) and electronics.

COMMUNICATIONS

MAGNETRONS

The following recommendations should be interpreted in conjunction with British Standard Code of Practice No. CP1005: 'The Use of Electronic Valves', Part 9, upon which these notes have, in part, been based.

1. HEATER

1.1. General

A cathode temperature either too high or low may lead to unsatisfactory operation such as moding and arcing, involving short life and loss of efficiency.

During operation the cathode temperature is increased by electron bombardment ('back heating'). The data sheets for magnetrons, therefore, usually contain information relating the heater voltage to the average anode input power so that the cathode temperature can be maintained at the desired level.

The heater voltage should be at the stated nominal when the h.t. is first applied, and be subsequently reduced as recommended in the data. In the case of magnetrons having cathodes of small thermal capacity, it may be necessary to reduce the heater voltage immediately the anode voltage is applied.

With some valves it may be required to limit the filament or heater current when switching on the supply. Information on this will generally be included on individual data sheets.

1.2. Indirectly heated oxide-coated cathodes

To obtain maximum life the heater voltage must be within $\pm 5\%$ of the value recommended for a particular operation.

1.3. Directly heated cathodes

Reference should be made to the individual data sheets.

2. INPUT AND OUTPUT CONNECTIONS

2.1. Input connection

The negative input voltage should be applied to the common heater-cathode terminal to avoid the flow of anode current through the heater which might be damaged.

In applications where a bifilar pulse transformer is used a non-inductive capacitor should be connected between the heater-cathode and heater terminals to suppress any high transient voltages.

2.2. Output connection

It is important that the type of output connection should be as specified in the data. Use of flat coupling instead of choke coupling or vice versa may upset the matching and possibly cause breakdown of the output system. Connections to the output must be designed to be sufficiently tight to avoid arcing and other faults. It is also important to avoid undue stressing of the output section which would either deform the metal or break the glass or ceramic vacuum seals. It is, therefore, necessary that any mechanical pressure be applied uniformly.

3. H.T. SUPPLY AND MODULATORS

3.1. General

The dynamic impedance of magnetrons is in general low; thus small variations in the applied voltage can cause appreciable changes in operating current. In the equipment design it is necessary to ensure that such variations in operating current do not lead to operation outside the published limits.

Current changes result in variation of power frequency and frequency spectrum quality and consequent deterioration of equipment performance. This factor should determine the maximum current change inherent in the equipment design under the worst operating conditions.

3.2. C.W. types

For c.w. types the amount of smoothing required in the h.t. supply depends on the amount of modulation, resulting from operating current variation, which can be tolerated.

Under certain operational conditions a c.w. magnetron can develop a negative resistance characteristic and a minimum value of series resistance which should be adjacent to the magnetron is given in individual data sheets.

3.3. Pulse types

To ensure a constant operating condition with a pulsed valve the modulator design must provide a pulse, the amplitude of which does not vary to any significant extent from pulse to pulse. The necessary design precautions depend on the type of modulator employed, and cannot be generalised.

The performance of a magnetron is often a sensitive function of the shape of the pulse that it receives and it is necessary to control four distinct aspects: rate of rise, spike, flat and rate of fall. In this connection it is important that any observation of the shape of the pulse, either of voltage or of current, supplied by the modulator should be made with a magnetron load and not with a dummy load, because a magnetron acts as a non-linear impedance. Furthermore, a magnetron is likely to be more sensitive to a mismatched load.

3.3.1. Rate of rise

Both maximum and minimum rates of rise of voltage (and sometimes current) may be specified. The most critical value is that just before and during the initiation of oscillation. Too high or low a rate of rise may accentuate the tendency to moding.

Too high a rate of rise may cause operation in the wrong mode or even failure to oscillate, and either of these conditions may lead to arcing due to overheating or to excessive voltages.

Operation at too low a rate of rise may also cause oscillation in the wrong mode or oscillation in the normal mode for an appreciable period at less than full current and this will cause frequency pushing leading to a broad frequency spectrum.

The rate of rise of voltage should be measured above the 80% point of the peak voltage corresponding to the onset of oscillation. For accuracy it is advisable to measure the rate of rise by means of a differentiating circuit whose total capacitance does not exceed 5% of the total stray capacitance of the modulator output circuit. Direct observation on an oscilloscope can be misleading due to the limitation of the oscilloscope and sampling device.



3.3.2. Spike

It is important that the voltage pulse should not have a high spike on the leading edge. Such a spike may cause the valve to start in an undesired mode. Although this operation may not be sustained, the transient condition may lead to destructive arcing. Measures taken to reduce the spike must not also reduce the rate of rise below the specified minimum.

3.3.3. Flat

The top of the voltage pulse should be free from ripple or droop since small changes in voltage cause large current variations resulting in frequency pushing. This leads to frequency modulation of the r.f. pulse and consequent broadening of the spectrum or instability.

3.3.4. Rate of fall

The fall of voltage must be rapid at least to the point where oscillation ceases, to avoid appreciable periods of operation below full current, with the attendant frequency pushing. This point is normally reached when the voltage has fallen to about 80% of the peak value.

Beyond this point a lower rate of fall is generally permissible, but a significant amount of noise will be generated, which may be detrimental to radar systems with a very short minimum range. To prevent coherent noise being generated especially in short range radars the voltage tail must decay to zero before the radar receiver recovers.

A fast rate of fall is also important where valves are operated at a high pulse recurrence frequency since any diode current which occurs after oscillations have ceased will add appreciably to the mean current and dissipation of the valve.

In certain applications it is desirable to return the valve cathode to a positive d.c. bias in order to speed up the rate of fall and to prevent diode current being passed during the inter-pulse period.

4. LOADING

The anode current range shown in individual data sheets is related to a maximum standing wave ratio seen by the magnetron of 1.5 to 1. Incorrect loading beyond this may reduce the current range for stable operation and can cause arcing or moding.

5. GENERATOR LOAD CHART (Rieke diagram)

A chart showing typical output power and frequency change plotted on a modified impedance circle diagram against magnitude (v.s.w.r.) and phase of the load seen by the magnetron, provides information on the behaviour of the magnetron to different load conditions.

Such a chart is often referred to as a Rieke diagram.

6. PHASE OF SINK

From the generator load chart it is seen that with a load of bad mismatch and at a particular phase, there is a region on the chart which is characterised by high power output and convergence of the frequency contours. This region is known as 'the sink' and the phase of the load at which the

magnetron behaves in this manner is known as 'the phase of sink'. Operation of the magnetron under this load condition will lead to instability and may cause failure of the magnetron. By matching the r.f. system such that the maximum permitted load v.s.w.r. is not exceeded, the sink will be avoided.

7. OPERATION IN DUPLEXER SYSTEMS

7.1. Position of t.r. cell

Where the r.f. systems incorporates a t.r. cell a bad load mismatch, which is unavoidable, is seen by the magnetron momentarily until the cell has been ionised. If the phase of this mismatch is such that it is in the phase of sink the build up of oscillation of the magnetron may be prevented. It is therefore essential that the t.r. cell is so positioned that its phase of mismatch as seen by the magnetron is remote from the sink region.

7.2. Position of minimum

In the non-oscillating condition the magnetron presents at its frequency of oscillation a bad mismatch of considerable magnitude to the r.f. system. This property is utilised in certain duplexer systems. In the design of such a system it is necessary to know the phase of the above load mismatch and this is designated at a position of minimum of the voltage standing wave in relation to a reference plane on the magnetron output system.

8. COOLING

8.1. General

The maximum temperature of the anode block, cathode terminal assembly and waveguide windows, where applicable, should on no account be exceeded. It may be necessary to provide additional cooling to prevent these temperature limits being exceeded. Where air or water cooling is necessary, interlock switches should be provided to prevent operation in the event of failure or reduction of cooling medium. In the development stage of an equipment the various temperatures should be measured with due regard to the ultimate environmental conditions. Special paints and lacquers are available for this purpose but any other suitable means may be used.

8.2. Air cooling

For the cooling of components such as input waveguide windows and output domes it is important that the air should not contain dust, moisture or grease.

8.3. Water cooling

The circulating cooling water should be as free as possible from all solid matter and the dissolved oxygen content should be low. Whenever possible a closed water system using distilled or demineralised water should be employed.



9. PRESSURISATION

The limiting values and operating conditions quoted in the data are given for a pressure of 650mm of mercury unless otherwise stated. In the case of high power magnetrons it may be necessary to pressurise the output waveguide in order to prevent electrical breakdown. Advice is given in the individual valve data sheets. Precautionary steps should be taken to prevent operation in the event of the failure of the pressurisation. In order to avoid dielectric breakdown, clean and dry air or gas must be used.

10. STORAGE

Valves should be stored in their original packing because this has been designed to protect the valve against reasonable vibration, and knocks. It also ensures that the spacing between permanent-magnet valves and other magnets or ferrous objects is adequate to avoid reduction of magnetisation. Despite this controlled spacing, magnetically-sensitive instruments such as compasses, electrical meters and watches should not be brought close to a bank of packaged magnetrons.

When a valve is protected by a moisture-proof container this fact is clearly stated on the outside. Unnecessary opening of the seal should be avoided so that the dessicant is not exhausted rapidly. When a magnetron is temporarily taken out of service it should be placed immediately in its proper container. This is a good practice which obviates the risk of damage to the magnet or to the glass or ceramic parts and prevents the entry of foreign matter into the output aperture.

Unpacked permanent-magnet valves should **NEVER** be placed on steel benches or shelves.

11. CONDITIONING

It is recommended that after transit or a long period of storage the anode voltage should be increased gradually or in several steps until normal operation is achieved. This treatment will clean up any traces of gases which could cause arcing or instability and this procedure is particularly important in high power magnetrons.

12. RADIATION HAZARDS

In general the shorter the wavelength of an r.f. radiation the greater the absorption by body tissues and hence for comparable power, the greater the hazard. With magnetrons the power may be sufficient to cause danger, particularly to the eyes.

If it is necessary to look directly into a magnetron output, this should be performed through an attenuating tube or through a small hole set in the wall of the waveguide at a bend. Alternatively r.f. screening such as copper gauze of mesh small compared with the wavelength must be provided.

With high power magnetrons precautions may also be necessary to reduce the stray r.f. radiation emitted through the cathode stem and other apertures, especially when the magnetron is functioning incorrectly.

High voltage magnetrons (as well as the high voltage rectifier and pulse modulator valves) can emit a significant intensity of X-rays and protection of the operator may be necessary. When magnetron behaviour is viewed through an aperture X-rays may be present. Protection of the eye is afforded by viewing through lead glass.

TUNABLE MAGNETRON

JNTI-500

Frequency: 'L' band, mechanically tunable.

Power output: 600kW, pulsed.

Construction: Unpackaged, forced-air cooled.

This data should be read in conjunction with GENERAL OPERATIONAL RECOMMENDATIONS—MICROWAVE DEVICES: INTRODUCTION and RADAR AND COMMUNICATION MAGNETRONS which precede this section of the handbook.

CHARACTERISTICS

	Min.	Max.	
Frequency			
Tunable over the range	1.22	1.35	Gc/s
Pulse voltage			
($I_{\text{pulse}} = 46\text{A}$, $H = 1.4\text{kG}$)	26.5	31.5	kV
R.F. pulse power output			
($I_{\text{pulse}} = 46\text{A}$, $H = 1.4\text{kG}$)	400	—	kW
Frequency pulling factor			
(v.s.w.r. = 1.5)	—	5.0	Mc/s
Frequency pushing factor	—	60	kc/s per A
Frequency temperature coefficient	—	-30	kc/s per °C

CATHODE

Indirectly heated

V_{h}	23.5	V
I_{h}	2.2	A
$I_{\text{h(surge)}}$ max.	4.0	A

Heating time. At ambient temperatures above 0°C the cathode must be heated for at least 3 minutes before the application of h.t. Below this temperature the heating time must be increased to at least 5 minutes.

It is necessary to reduce the heater voltage immediately after the application of h.t. and if operation substantially different from that shown under typical operation is envisaged Mullard Ltd. should be consulted.

TYPICAL OPERATION

f	1.285	Gc/s
Heater voltage (running)	15.5	V
Pulse duration	1.0	μs
Pulse repetition frequency	1000	p/s
Duty cycle	0.001	
Pulse current	46	A
Pulse voltage	27.2	kV
Pulse input power	1.25	MW
R.F. pulse output power	610	kW
Mean input current	46	mA
Mean input power	1.25	kW
Mean r.f. output power	610	W
Frequency pulling (v.s.w.r. = 1.5)	4.0	Mc/s
Rate of rise of pulse voltage	60	kV/μs
Magnetic field strength	1.4	kG

OPERATING NOTES

1. The magnetron is designed to feed into a 50Ω, 1 $\frac{1}{8}$ inch coaxial transmission line.
2. The maximum torque to be applied to the driving gear wheel for tuning the magnetron should not exceed 8lb. in (9.2kg.cm).
3. The coaxial outlet should be protected by a dust cover when the magnetron is not in use.

COOLING

It is necessary to direct a flow of cooling air between the radiator fins, and on the cathode and heater seals, in order to keep the temperature below the permitted maximum.

LIMITING VALUES (absolute ratings)

	Min.	Max.	
Pulse current	25	60	A
Pulse voltage	24	34	kV
Pulse duration	1.0	6.0	μ s
Duty cycle	—	0.002	
Mean input power	—	1.8	kW
Rate of rise of voltage pulse			
$t_p \leq 1.0 \mu$ s	—	70	kV/ μ s
$t_p = 1.0 \leq 5.0 \mu$ s	—	30	kV/ μ s
Load mismatch (v.s.w.r.)	—	1.5	
Temperature of anode block	—	125	$^{\circ}$ C

MOUNTING POSITION

Any

PRESSURISING

The output system may be pressurised up to a pressure of 1550 torr.

PHYSICAL DATA

Weight of magnetron	{ 19lb 13oz { 9 kg { 37lb 8oz { 17 kg
Weight of magnetron in carton	

ACCESSORY

Permanent magnet	55302
------------------	-------

DIMENSIONS

	Inches		Millimetres			Inches		Millimetres		
A	4.496		114.2		max.	P	0.012		0.31	min.
B	2.000		50.8		max.	Q	0.281	0.003	7.135	0.075
C	3.374		85.7		max.	R	0.169	0.005	4.30	0.13
D	12.500		317.5		max.	S	4.750		120.65	max.
E	9.185		233.3		max.	T	1.036		26.31	
F	8.000	0.185	203.2	4.7		U	0.904		22.96	
G	5.469	0.061	138.90	1.55		V	0.125	0.003	3.175	0.075
H	0.250	0.002	6.35	0.05		W	0.010		0.25	max.
					(square hole)	X	3.055	0.007	77.585	0.185
J	2.310	0.003	58.6625	0.0625		Y	0.564	0.010	14.325	0.255
K	0.376	0.014	9.55	0.35		Z	1.577	0.010	40.05	0.25
*L	2.312		58.7			AA	1.931	0.004	49.05	0.10
M	3.000		76.2		max.	BB	3.505	0.055	89.025	1.395
N	0.592	0.002	15.04	0.04	max.	CC	0.375	0.002	9.525	0.055

[†]Thread specification—5 full threads minimum

Maximum major diameter = 58.75mm, 2.313in.

Minimum major diameter = 58.37mm, 2.298in.

Maximum pitch diameter = 57.69mm, 2.271in.

Minimum pitch diameter = 57.48mm, 2.263in.

Minimum minor diameter = 56.78mm, 2.235in.

Coincident arrows indicate approximate midband frequencies

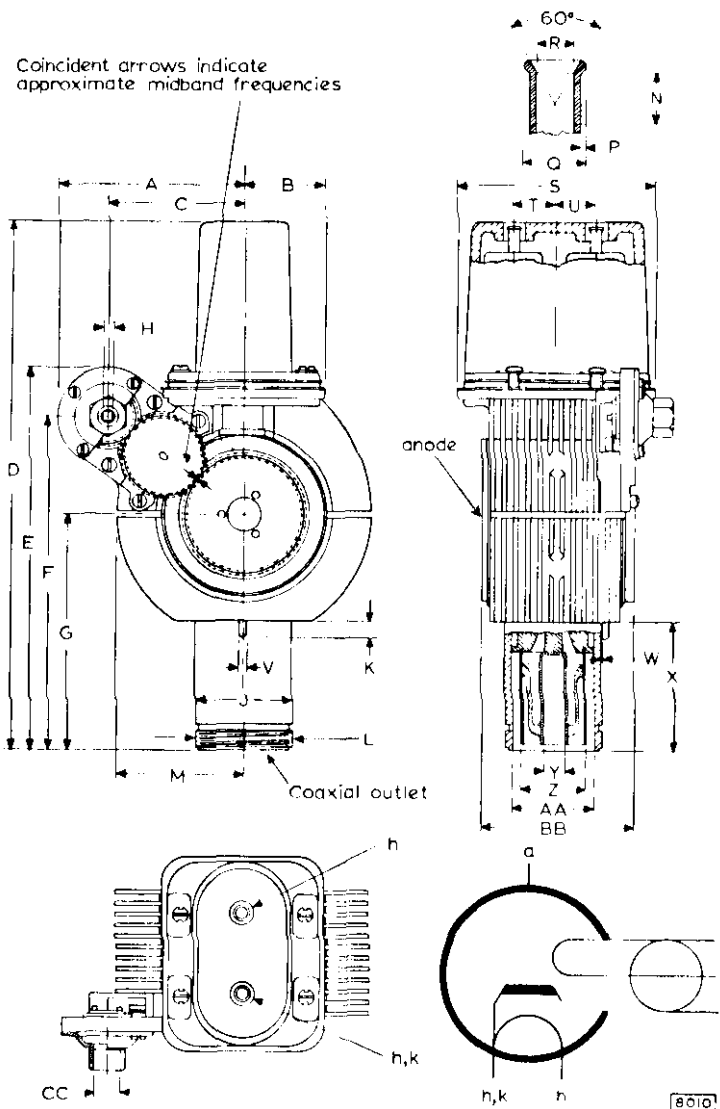

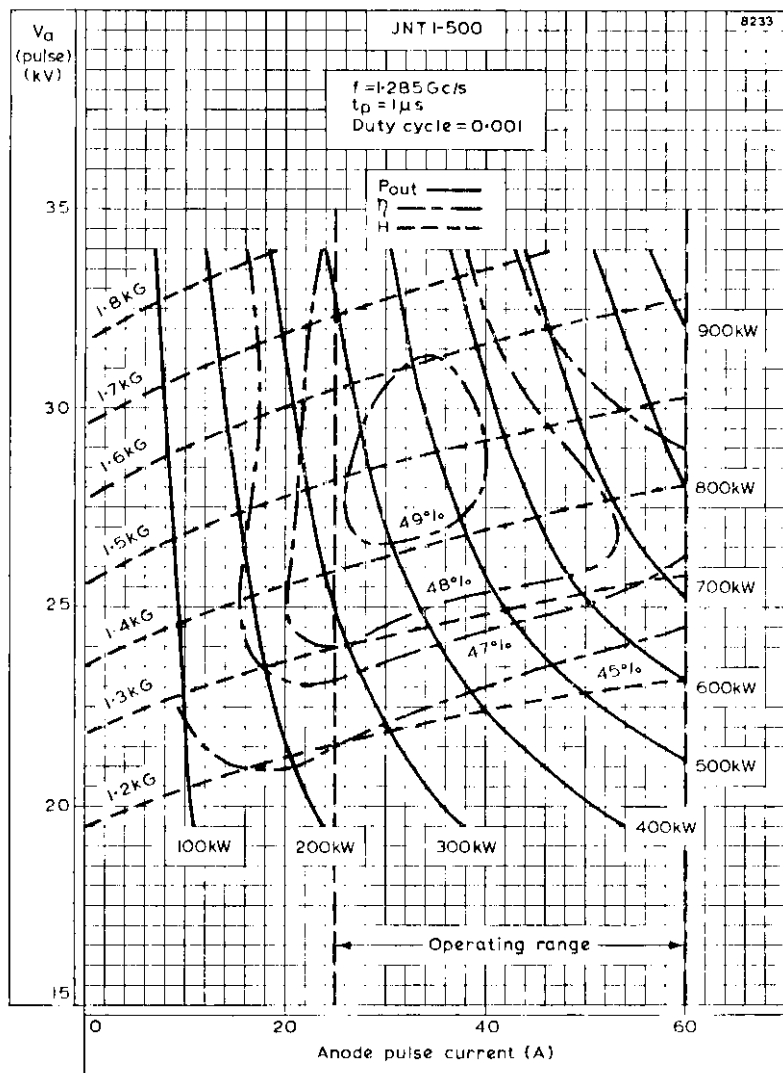

ANODE PULSE VOLTAGE PLOTTED AGAINST ANODE PULSE CURRENT WITH R.F. PULSE POWER OUTPUT, MAGNETIC FIELD STRENGTH AND EFFICIENCY AS PARAMETERS

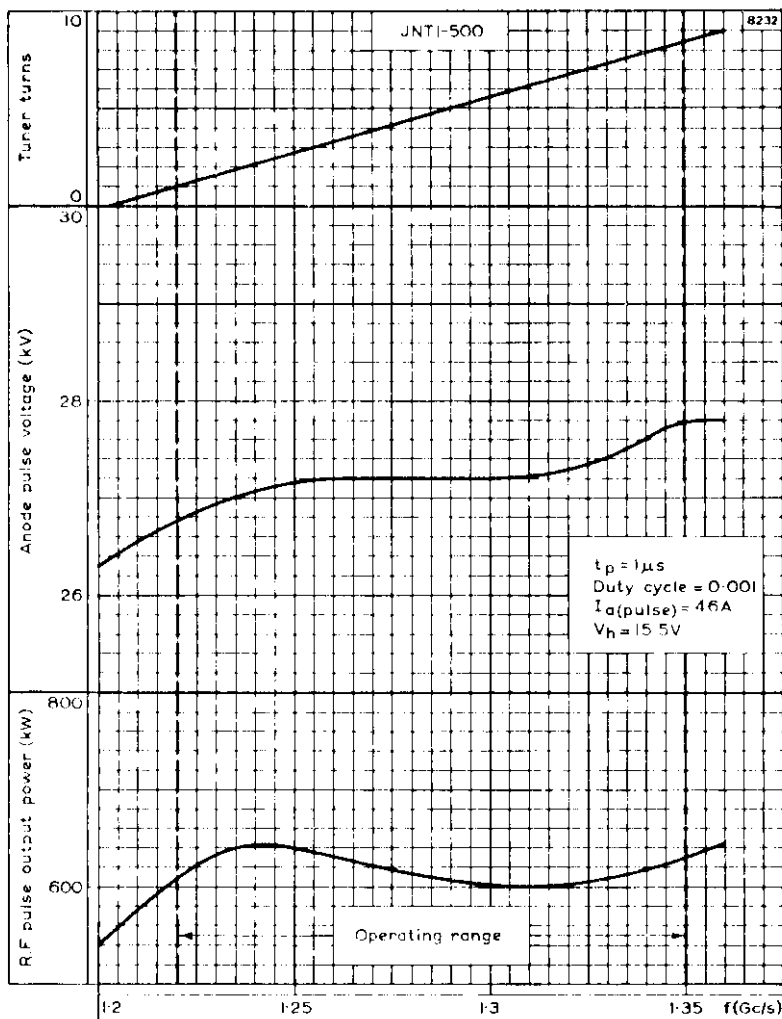

TUNER TURNS, ANODE PULSE VOLTAGE AND R.F. PULSE OUTPUT POWER PLOTTED AGAINST FREQUENCY



PRELIMINARY DATA

QUICK REFERENCE DATA

Forced-air cooled fixed frequency 'X' band pulsed magnetron, with high duty ratio. Suitable for airborne doppler navigation equipment.

Frequency	8.80	Gc/s
Power output (pulsed)	25	W
Construction		Packaged

This data should be read in conjunction with GENERAL OPERATIONAL RECOMMENDATIONS—MICROWAVE DEVICES: INTRODUCTION and RADAR AND COMMUNICATION MAGNETRONS which precede this section of the handbook.

CHARACTERISTICS

	Min.	Max.	
Frequency			
Fixed within the band	8.77	to 8.83	Gc/s
Pulse voltage ($I_{\text{pulse}} = 150\text{mA}$)	750	850	V
R.F. pulse power output ($I_{\text{pulse}} = 150\text{mA}$)	17	—	W
Frequency pulling factor (v.s.w.r. = 1.5)	—	15	Mc/s
Frequency pushing factor	—	0.125	Mc/s per mA
Frequency temperature coefficient	—	-0.25	Mc/s per °C
Input capacitance	—	9.0	pf

CATHODE

Indirectly heated

V_c	6.3	V
I_{h}	1.2	A

Heating time. At ambient temperatures above 0°C the cathode must be heated for at least 2 minutes before the application of h.t. Below this temperature the heating time must be increased to at least 3 minutes.

TYPICAL OPERATION

Heater voltage (running)	5.5	4.5	V
Pulse duration	4.0	4.0	μs
Pulse repetition frequency	100,000	100,000	p/s
Duty cycle	0.2	0.4	
Pulse current	150	150	mA
Pulse voltage	800	800	V
R.F. pulse output power	25	25	W
Mean input current	60	60	mA
Mean input power	48	48	W
Mean r.f. output power	10	10	W
Frequency pulling factor (v.s.w.r. = 1.5)	12	12	Mc/s
Rate of rise of pulse voltage	4.0	4.0	kV/ μs

COOLING

It is necessary to direct a flow of cooling air between the radiator fins, in order to keep the temperature below the permitted maximum.

ABSOLUTE MAXIMUM RATINGS

	Min.	Max.	
Pulse current	110	180	mA
Pulse duration	—	5.0	μ s
Duty cycle	—	0.5	
Mean input power	—	60	W
Rate of rise of voltage pulse	—	5.0	kV/ μ s
Load mismatch (v.s.w.r.)	—	1.5	
Temperature of anode block	—	140	$^{\circ}$ C

END OF LIFE PERFORMANCE

R.F. pulse power output ($I_{\text{pulse}} = 150\text{mA}$)		15	W
	Min.	Max.	
Frequency			
Within the band	8.77	to 8.83	Gc/s
Pulse voltage ($I_{\text{pulse}} = 150\text{mA}$)	750	850	V

MOUNTING POSITION

Any

PHYSICAL DATA

Weight of magnetron	{	1.0	lb
		454	g
Weight of magnetron in carton	{	2 lb	4 oz
		1.02	kg
Dimensions of storage carton	{	5.0 x 7.25 x 7.25	in
		127 x 184 x 184	mm

DIMENSIONS

	Inches	Millimetres	
A	2.36	60	max
B	1.26	32	max
C	1.73	44	max
D	1.73	44	max
E	1.53 \pm 0.02	13.5 \pm 0.5	
F	1.77	45	max
G	1.22 \pm 0.08	31 \pm 2	
J	0.51	13	max
K	1.14	29	max
L	0.79	20	max
P	0.32 \pm 0.04	8 \pm 1	
Q	0.64	16.2	
R	0.61	15.5	

9417

Terminals for heater and cathode.
Common heater-cathode terminal marked 'k'

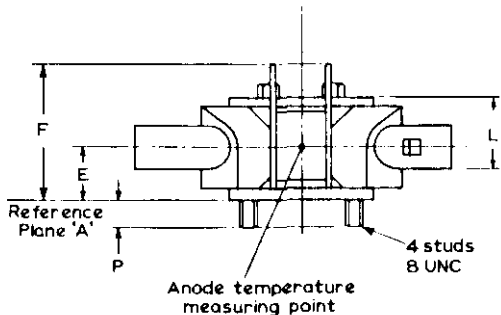
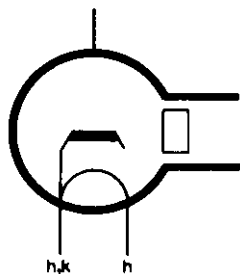
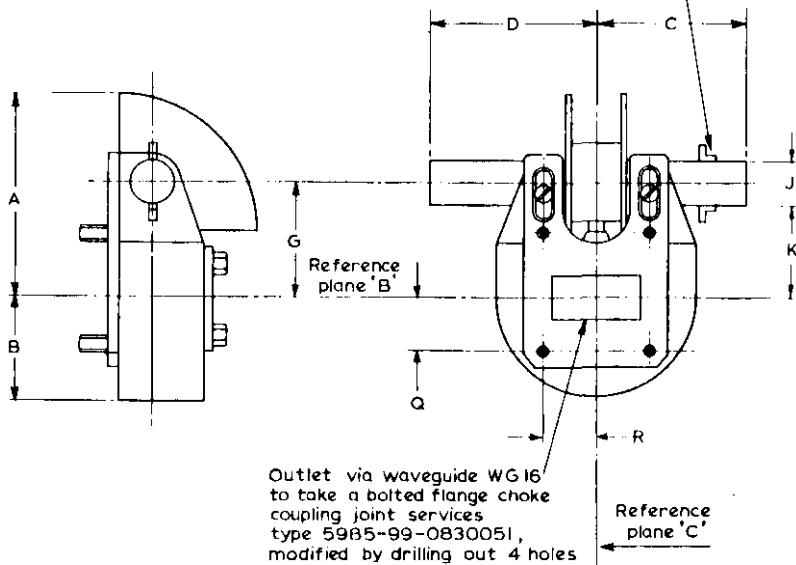

ANODE CONNECTION IS TERMINATED AT THE BASE PLATE

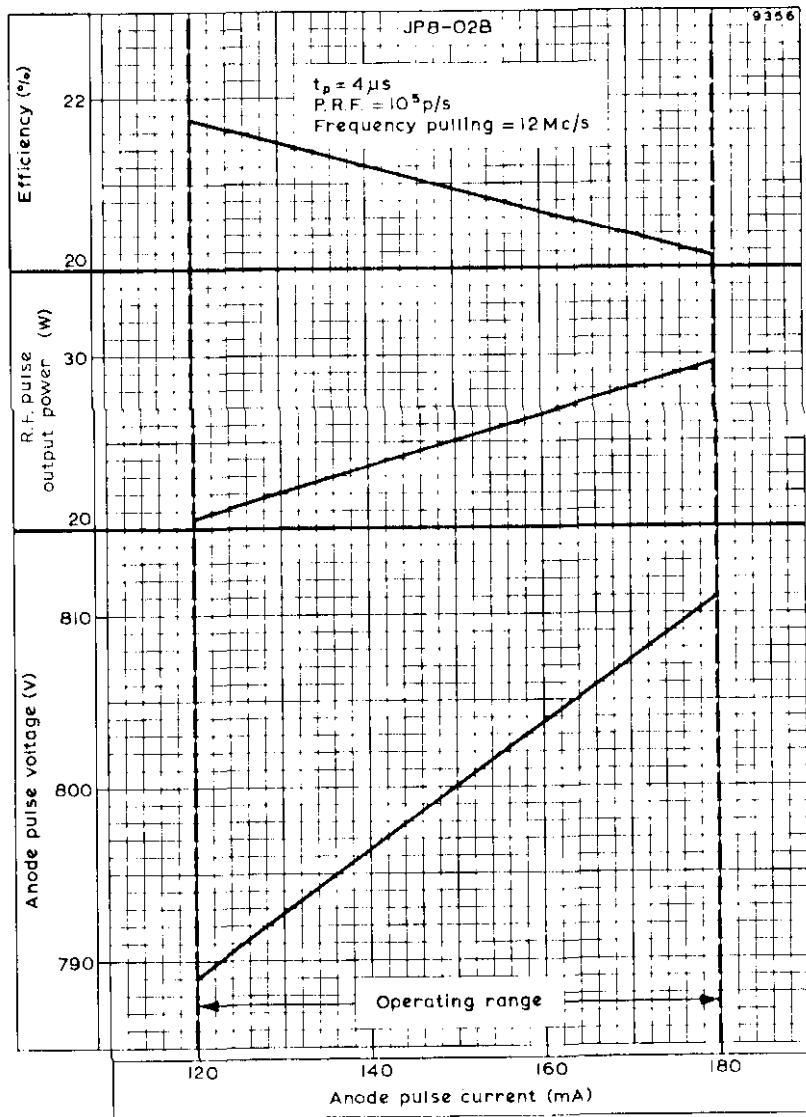

ANODE PULSE VOLTAGE, R.F. PULSE OUTPUT POWER AND EFFICIENCY PLOTTED AGAINST ANODE PULSE CURRENT

PRELIMINARY DATA

QUICK REFERENCE DATA

Forced-air cooled fixed frequency 'X' band pulsed magnetron, with high duty ratio. Suitable for airborne doppler navigation equipment.

Frequency	8.80 Gc/s
Power output (pulsed)	25 W
Construction	Packaged

This data should be read in conjunction with GENERAL OPERATIONAL RECOMMENDATIONS - MICROWAVE DEVICES: INTRODUCTION and RADAR AND COMMUNICATION MAGNETRONS which precede this section of the handbook.

CHARACTERISTICS

	Min.	Max.	
Frequency	8.77 to	8.83	Gc/s
Fixed within the band			
Pulse voltage ($I_{\text{pulse}} = 150\text{mA}$)	750	850	V
R.F. pulse output power ($I_{\text{pulse}} = 150\text{mA}$)	17	—	W
Frequency pulling factor (v.s.w.r. = 1.5)	—	15	Mc/s
Frequency pushing factor	—	0.125	Mc/s per mA
Frequency temperature coefficient	—	-0.25	Mc/s per °C
Input capacitance	—	9.0	pF

CATHODE

Indirectly heated

V_h	6.3	V
I_h	1.2	A

Heating Time. At ambient temperatures above 0°C the cathode must be heated for at least 2 minutes before the application of h.t. Below this temperature the heating time must be increased to at least 3 minutes.

TYPICAL OPERATION

Heater voltage (running)	5.5	V
Pulse duration	4.0	μs
Pulse repetition frequency	50,000	p/s
Duty cycle	0.2	
Pulse current	150	mA
Pulse voltage	800	V
R.F. pulse output power	25	W
Mean input current	30	mA
Mean input power	24	W
Mean r.f. output power	5	W
Frequency pulling (v.s.w.r. = 1.5)	12	Mc/s
Rate of rise of pulse voltage	3.0	kV/μs

COOLING

It is necessary to direct a flow of cooling air between the radiator fins, in order to keep the temperature below the permitted maximum.

ABSOLUTE MAXIMUM RATINGS

	Min.	Max.	
Pulse current	120	180	mA
Pulse duration	—	5.0	μ s
Duty cycle	—	0.25	
Mean input power	—	30	W
Rate of rise of voltage pulse	—	4.0	kV/ μ s
Load mismatch (v.s.w.r.)	—	1.5	
Temperature of anode block	—	140	$^{\circ}$ C

END OF LIFE PERFORMANCE

	Min.	Max.	
R.F. pulse power output ($I_{pulse} = 150$ mA)		15	W
Frequency			
Within the band	8.77 to	8.83	Gc/s
Pulse voltage ($I_{pulse} = 150$ mA)	750	850	V

MOUNTING POSITION

Any

PHYSICAL DATA

Weight of magnetron	{ 1.0 lb 454 g
Weight of magnetron in carton	{ 2 lb 4 oz 1.02 kg
Dimensions of storage carton	{ 5.0 x 7.25 x 7.25 in 127 x 184 x 184 mm

DIMENSIONS

	Inches	Millimetres	
A	2.36	60	max.
B	1.26	32	max.
C	1.73	44	max.
D	1.73	44	max.
E	0.53 \pm 0.02	13.5 \pm 0.5	
F	1.77	45	max.
G	1.22 \pm 0.08	31 \pm 2	
J	0.51	13	max.
K	1.14	29	max.
L	0.79	20	max.
P	0.32 \pm 0.04	8 \pm 1	
Q	0.64	16.2	
R	0.61	15.5	

[9417]

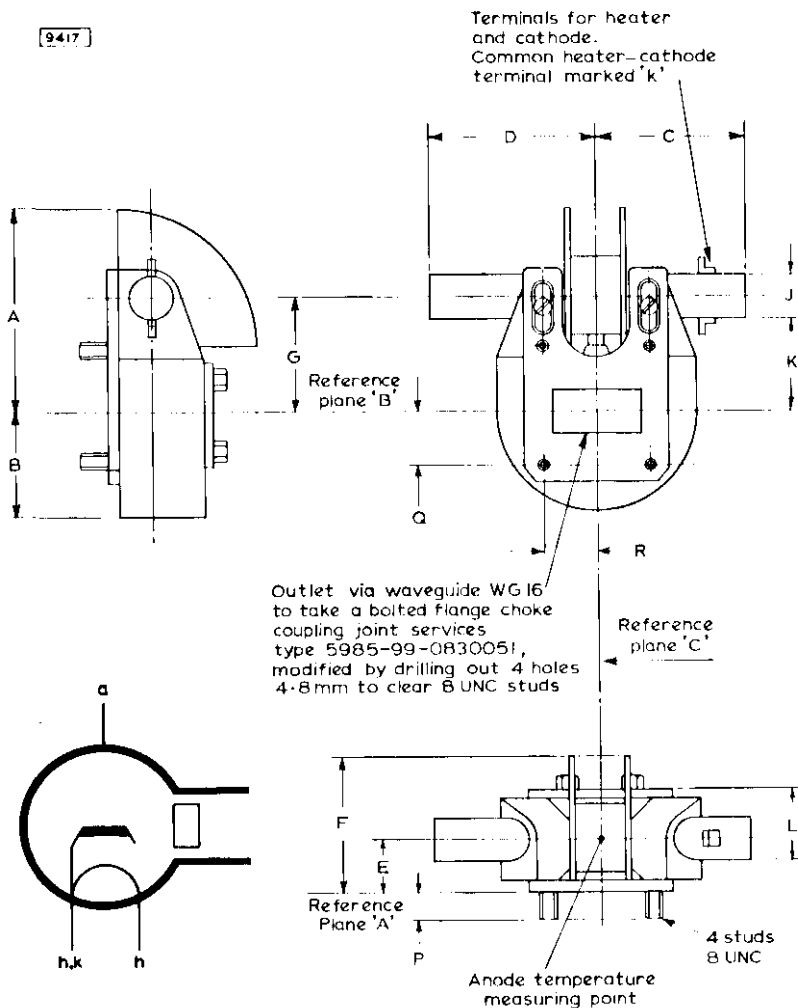

ANODE CONNECTION IS TERMINATED AT THE BASE PLATE

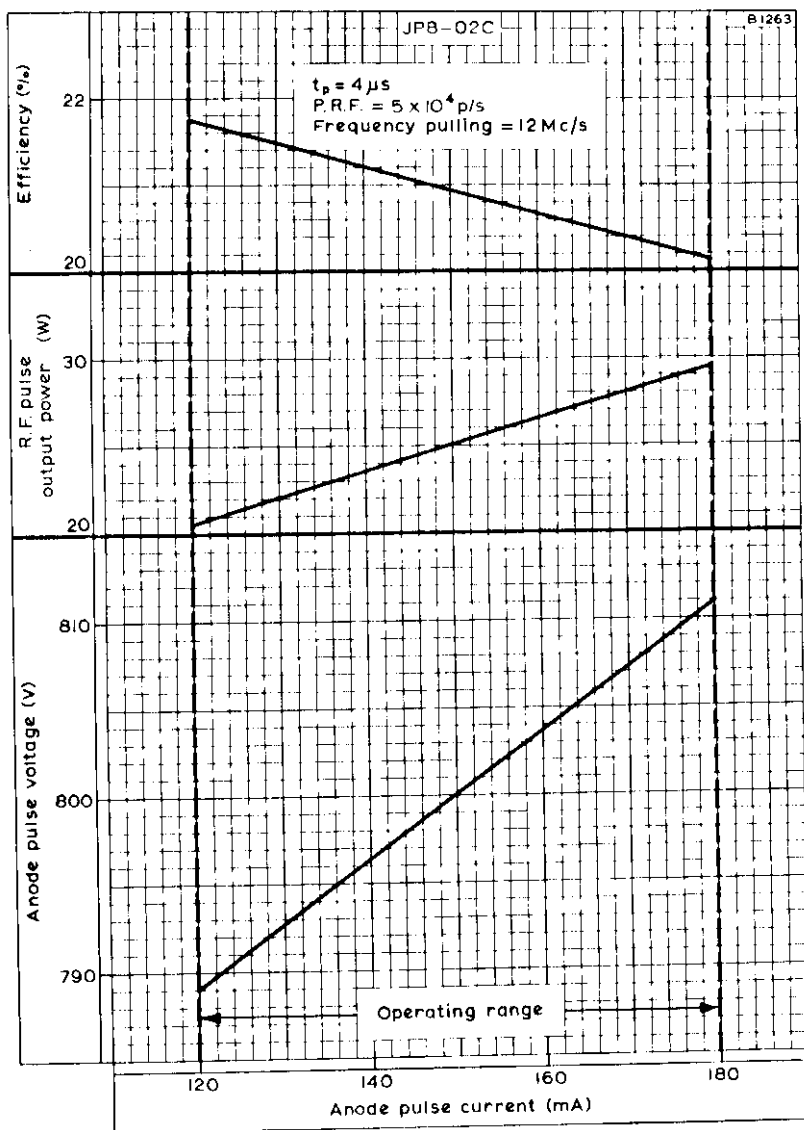

ANODE PULSE VOLTAGE, R.F. PULSE OUTPUT POWER AND EFFICIENCY
PLOTTED AGAINST ANODE PULSE CURRENT

QUICK REFERENCE DATA

Fixed-frequency 'X' band c.w. magnetron

Frequency	10.595	Gc/s
Power output (c.w.)	10	W

To be read in conjunction with
GENERAL OPERATIONAL RECOMMENDATIONS - MICROWAVE DEVICES

Heater voltage (running)	0.0	V
Operating current	50	mA
Operating voltage	930	V
Input power	46	W
Frequency pulling (v.s.w.r. = 1.5)	13	Mc/s

CATHODE

Indirectly heated

V_h	6.3	V
I_h	1.2	A
Heating time		

At ambient temperatures above 0°C the cathode must be heated for at least 2 minutes before the application of h.t. Below this temperature the heating time must be increased to at least 3 minutes.

RATINGS (ABSOLUTE MAXIMUM SYSTEM)

	Min.	Max.	
Operating current (unmodulated c.w.)	20	60	mA
Peak operating current (modulated c.w.)	-	100	mA
Mean input power	-	60	W
Load mismatch (v.s.w.r.)	-	1.5	
Temperature of anode block	-	140	°C

OPERATING NOTE

A limiting resistor of 1k Ω should be inserted in series with the magnetron.

END OF LIFE PERFORMANCE

The valve is deemed to have reached end of life when it fails to satisfy the following: -

	Min.	Max.	
R.F. power output (I = 50mA)		6.0	W
Frequency			
Within the band	9,345	to 9,405	Gc/s
Operating voltage (I = 50mA)	0.9	to 1.1	kV

MOUNTING POSITION

Any

PHYSICAL DATA

	lb	kg
Weight of magnetron	1.0	0.45
Weight of magnetron in carton	2.25	1.02
	in	cm
Dimensions of storage carton	5.0 × 7.25 × 7.25	12.7 × 18.4 × 18.4

COOLING

It is necessary to direct a flow of cooling air between the radiator fins in order to keep the anode block temperature below the permitted maximum.

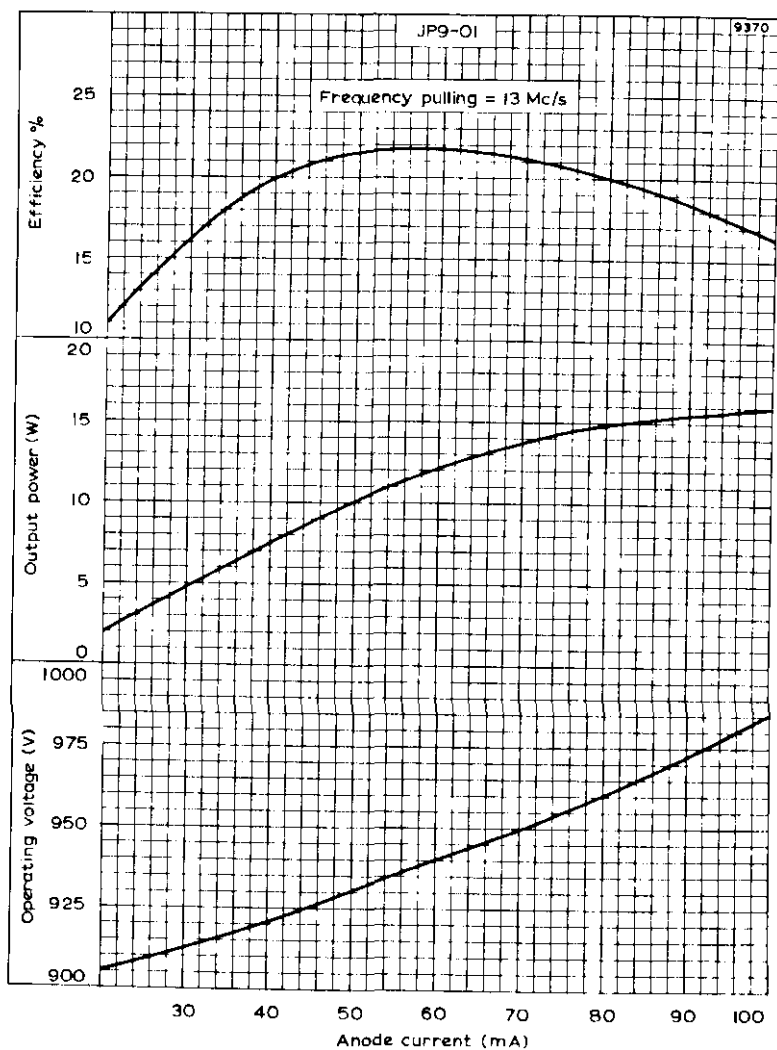

OPERATING VOLTAGE, R. F. POWER OUTPUT AND EFFICIENCY
PLOTTED AGAINST ANODE CURRENT

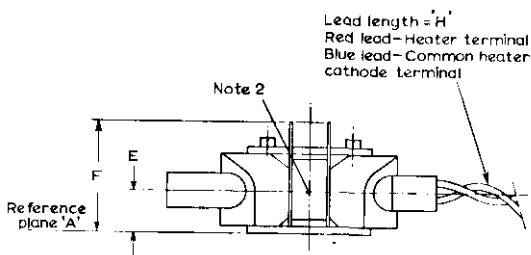
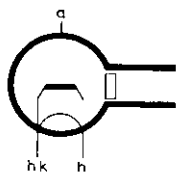
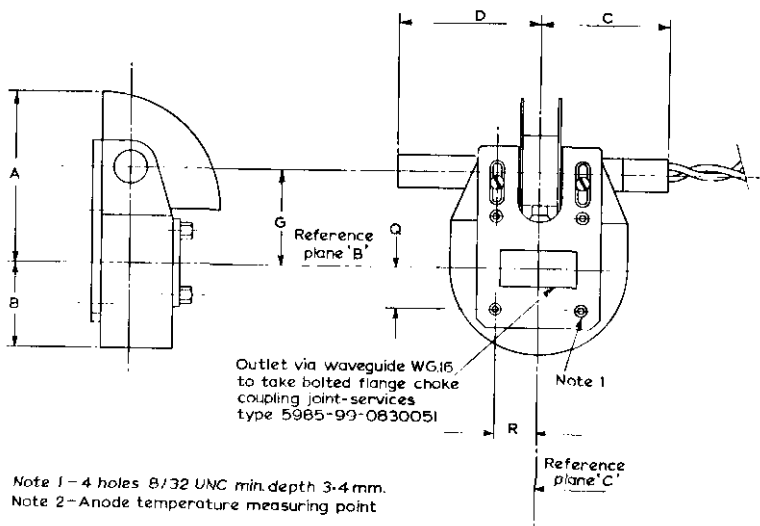

0260

ANODE CONNECTION TERMINATED AT THE BASE PLATE

DIMENSIONS

	Inches	Millimetres		Inches	Millimetres
A	2.36	60 max.	F	1.77	45 max.
B	1.25	32 max.	G	1.220 ± 0.079	31 ± 2
C	1.96	50 max.	H	5.12 ± 0.20	130 ± 5
D	1.73	44 max.	Q	0.638	16.2
E	0.531 ± 0.020	13.5 ± 0.5	R	0.610	15.5

Inch dimensions derived from original millimetre dimensions

QUICK REFERENCE DATA

Fixed frequency 'X' band magnetron with natural cooling

Frequency JP9-2.5	9.410 Gc/s
JP9-2.5B	9.255 Gc/s
JP9-2.5C	9.550 Gc/s
Power output (pulsed)	3.0 kW
Construction	Packaged

Unless otherwise shown data is applicable to all types.

This data should be read in conjunction with GENERAL OPERATIONAL RECOMMENDATIONS - MICROWAVE DEVICES: INTRODUCTION and RADAR AND COMMUNICATION MAGNETRONS which precede this section of the handbook.

CHARACTERISTICS

		Min.	Max.	
Frequency				
Fixed within the band	JP9-2.5	9.345 to	9.475	Gc/s
	JP9-2.5B	9.190 to	9.320	Gc/s
	JP9-2.5C	9.520 to	9.580	Gc/s
Pulse voltage ($I_{\text{pulse}} = 3.0\text{A}$)		3.20	3.80	kV
R.F. pulse power output ($I_{\text{pulse}} = 3.0\text{A}$)		2.5	—	kW
Frequency pulling factor (v.s.w.r. = 1.5)		—	18	Mc/s
Frequency pushing factor		—	2.5	Mc/s per A
Frequency temperature coefficient		—	0.25	Mc/s per °C
Distance of v.s.w. minimum from face of mounting plate into valve	JP9-2.5	0	6	mm
	JP9-2.5B	0	6	mm
	JP9-2.5C	3	9	mm
Input capacitance		—	9.0	pF

TYPICAL OPERATION

Duty cycle	0.0002	
Heater voltage (running)	6.3	V
Pulse duration	0.1	μs
Pulse repetition frequency	2000	p/s
Pulse current	3.0	A
Pulse voltage	3.4	kV
Pulse input power	10	kW
R.F. pulse output power	3.0	kW
Mean input current	600	μA
Mean input power	2.0	W
Mean r.f. output power	600	mW
Frequency pulling (v.s.w.r. = 1.5)	15	Mc/s
Rate of rise of pulse voltage	50	kV/ μs

CATHODE

Indirectly heated

V_h	6.3	V
I_h	500	mA

Heating time. At ambient temperatures above 0°C the cathode must be heated for at least 2 minutes before the application of h.t. Below this temperature the heating time must be increased to at least 3 minutes.

ABSOLUTE MAXIMUM RATINGS

	Min.	Max.	
Pulse current	2.5	3.5	A ←
Pulse duration	0.02	1.0	μs
Duty cycle	—	0.001	
Mean input power	—	13	W
Rate of rise of voltage pulse	—	60	kV/μs
Load mismatch (v.s.w.r.)	—	1.5	
Temperature of anode block	—	120	°C

END OF LIFE PERFORMANCE

	Min.	Max.	
R.F. pulse power output ($I_{pulse} = 3.0A$)		2.0	kW ←
Frequency			
Within the band			
JP9-2.5	9.345 to	9.475	Gc/s
JP9-2.5B	9.190 to	9.320	Gc/s
JP9-2.5C	9.520 to	9.580	Gc/s
Pulse voltage ($I_{pulse} = 3.0A$)	3.2	3.8	kV

MOUNTING POSITION

Any

PHYSICAL DATA

Weight of magnetron	{ 2 lb 1.02	4 oz kg
Weight of magnetron in carton	{ 4 lb 1.82	0 oz kg
Dimensions of storage carton	{ 7.5 × 7.5 × 11 190 × 190 × 280	in mm

DIMENSIONS

	<i>Inches</i>	<i>Millimetres</i>	
A	1.181	30	max.
B	1.625 ± 0.015	41.28 ± 0.38	
C	3.463 ± 0.001	87.960 ± 0.025	
D	0.591	15	max.
E	1.521 ± 0.001	38.633 ± 0.025	
F	0.450 ± 0.001	11.400 ± 0.025	
G	0.610 ± 0.001	15.500 ± 0.025	
H	0.984	25	max.
J	0.200 ± 0.001	5.100 ± 0.025	
K	0.640 ± 0.001	16.255 ± 0.025	
L	0.175 ± 0.003	4.44 ± 0.08	
M	1.457	37	max.
P	4.528	115	max.
Q	0.428 ± 0.167	12.25 ± 4.25	
R	2.717 ± 0.156	69 ± 4	
S	0.157	4.0	min.
T	5.335 ± 0.007	135.50 ± 0.17	
U	0.175 ± 0.003	4.445 ± 0.076	dia.
V	0.170 ± 0.001	4.318 ± 0.025	dia.
W	8.000 ± 0.500	203.20 ± 12.70	
X	1.772	45	max.
Y	2.165	55	max.

JP9-2.5
 JP9-2.5B
 JP9-2.5C

MAGNETRON

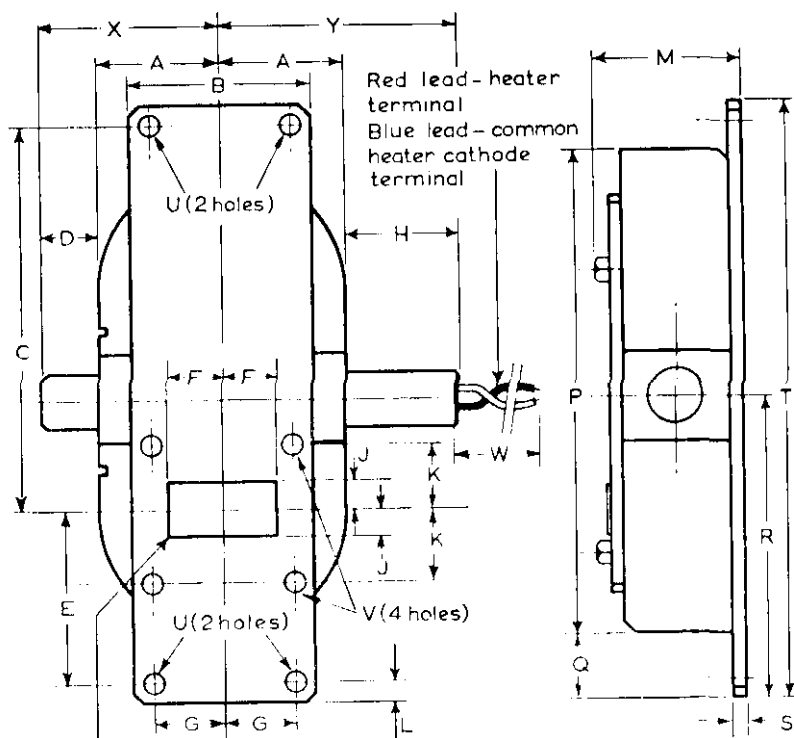

Outlet via waveguide WG16
 to take bolted flange choke
 coupling joint-services
 type 5985-99-0830051

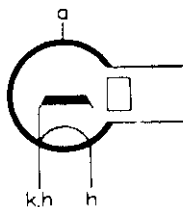

800B

THE ANODE IS TERMINATED AT THE BASE PLATE

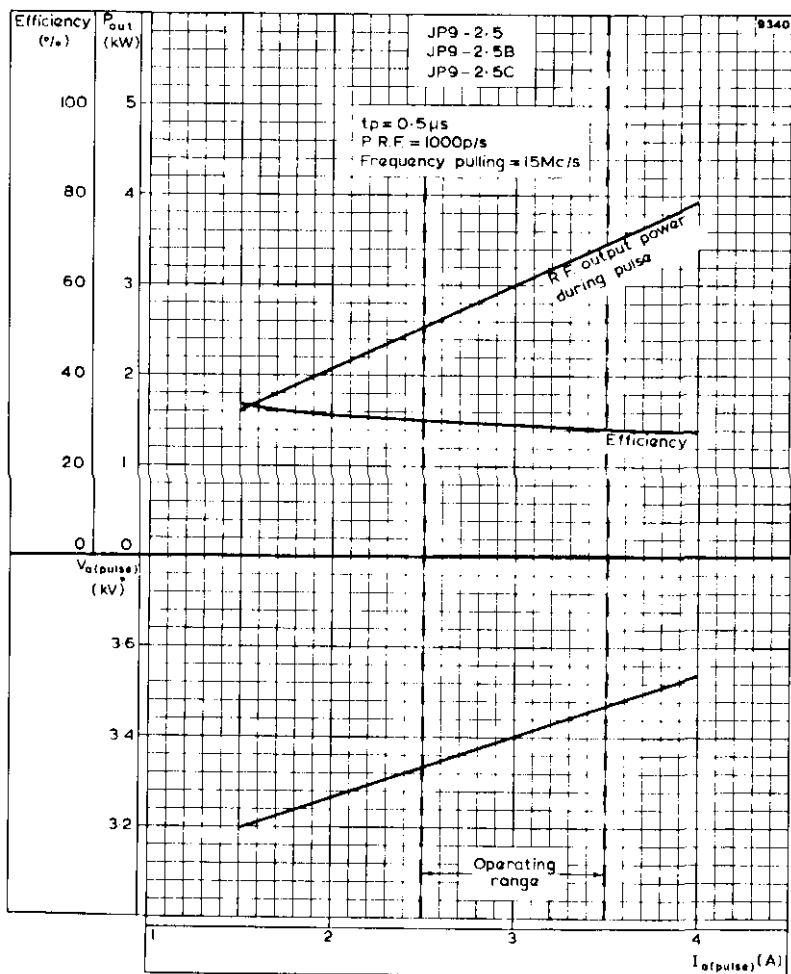

ANODE PULSE VOLTAGE, R.F. OUTPUT POWER DURING PULSE AND EFFICIENCY PLOTTED AGAINST ANODE PULSE CURRENT

JP9-2.5 JP9-2.5B JP9-2.5C

MAGNETRON

JP9-2.5
JP9-2.5B
JP9-2.5C

Measured towards
magnetron

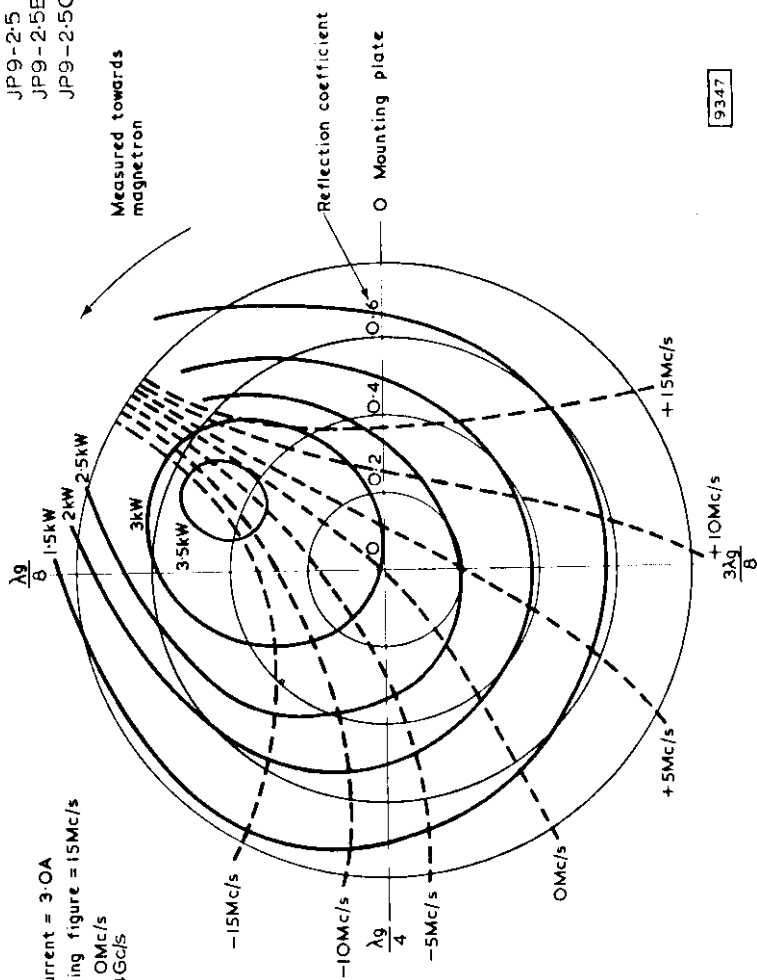

Anode pulse current = 3.0A
Frequency pulling figure = 15Mc/s
Frequency of 0Mc/s contour = 9.4Gc/s

RIEKE DIAGRAM



QUICK REFERENCE DATA

Fixed frequency 'X' band magnetron with natural cooling.

Frequency	9.445	9.445	Gc/s
Power output (pulsed)		3.0	kW

To be read in conjunction with GENERAL OPERATIONAL RECOMMENDATIONS - MICROWAVE DEVICES.

Unless otherwise shown, data is applicable to both types.

CHARACTERISTICS

	Min.		Max.	
Frequency				
Fixed within the band	9.415	to	9.475	Gc/s
Pulse voltage (1 pulse = 3.0A)	3.2		3.8	kV
R. F. pulse power output (1 pulse = 3.0A)	2.5		-	kW
Frequency pulling (v. s. w. r. = 1.5)	-		18	Mc/s
Frequency temperature coefficient			0.25	Mc/s per °C
Distance of v. s. w. minimum from face of mounting plate into valve	*3 **0		9 6	mm mm
Input capacitance			9.0	pF
Frequency pushing			2.5	Mc/s per A
*JP9-2.5D **JP9-2.5E				

TYPICAL OPERATION

R. F. pulse power output		3.0	kW
Duty factor		0.0002	
Pulse duration		0.1	μs
Pulse repetition frequency		2000	p. p. s.
Heater voltage (running)		6.3	V
Pulse current		3.0	A
Pulse voltage		3.5	kV
Pulse input power		10	kW
Rate of rise of voltage pulse		50	kV/μs
Mean input current		0.6	mA
Mean input power		2.0	W
Mean r. f. output power		0.6	W
Frequency pulling (v. s. w. r. = 1.5)		15	Mc/s

CATHODE

Indirectly heated

V _h	6.3	V
I _h	0.5	A

Heating time. At ambient temperatures above 0°C the cathode must be heated for at least 2 minutes before the application of h.t. Below this temperature the heating time must be increased to at least 3 minutes.

ABSOLUTE MAXIMUM RATINGS

	Min.	Max.	
Pulse current	2.5	3.5	A
Pulse duration	0.02	1.0	μs
Duty factor	-	0.001	
Mean input power	-	13	W
Rate of rise of voltage pulse	-	60	kV/μs
Load mismatch (v. s. w. r.)	-	1.5	
Temperature of anode block	-	120	°C

END OF LIFE PERFORMANCE

The valve is deemed to have reached end of life when it fails to satisfy the following :-

R. F. pulse power output (I pulse = 3.0A) 2.0 kW

	Min.	Max.	
Frequency			
Within the band	9.415 to	9.475	Gc/s
Pulse voltage (I pulse = 3.0A)	3.2 to	3.8	kV

MOUNTING POSITION

Any



PHYSICAL DATA

	lb	kg
Weight of magnetron	2.25	1.02
Weight of magnetron in carton	4.0	1.82
	in	cm
Dimensions of storage carton	7.5 x 7.5 x 11	19 x 19 x 28

DIMENSIONS

	Inches	Millimetres	
B	1.025 ± 0.015	41.28 ± 0.40	
C	3.463 ± 0.004	87.960 ± 0.10	
E	1.521 ± 0.004	38.633 ± 0.10	
G	0.610 ± 0.002	15.500 ± 0.05	
K	0.640 ± 0.004	16.255 ± 0.10	
M	1.457	37	max
T	5.335 ± 0.007	135.50 ± 0.17	
W	8.000 ± 0.500	203.20 ± 12.70	
X	1.772	45	max
Y	2.165	55	max

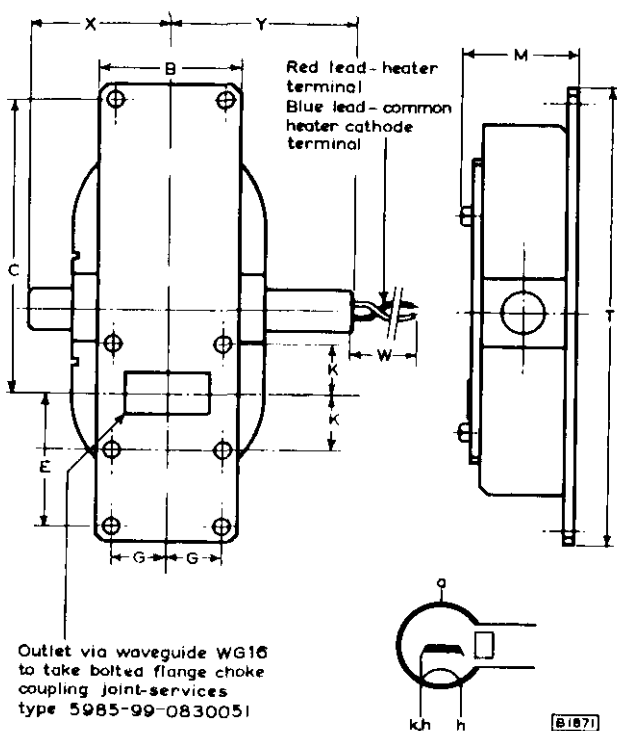

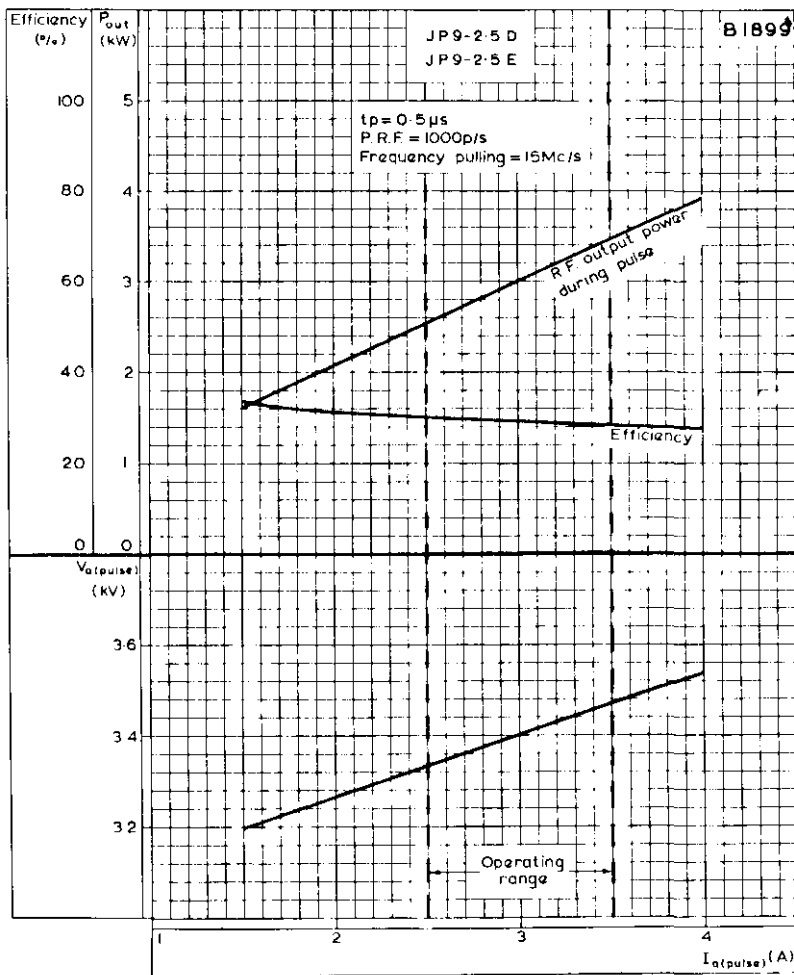

ANODE PULSE VOLTAGE, R. F. PULSE OUTPUT POWER AND EFFICIENCY PLOTTED AGAINST ANODE PULSE CURRENT

JP9-2.5D
JP9-2.5F

Anode pulse current = 3.0A
Frequency pulling figure = 15Mc/s
Frequency of OMc/s
contour = 9.4Gc/s

Measured towards
magnetron

Reflection coefficient

O Mounting plate

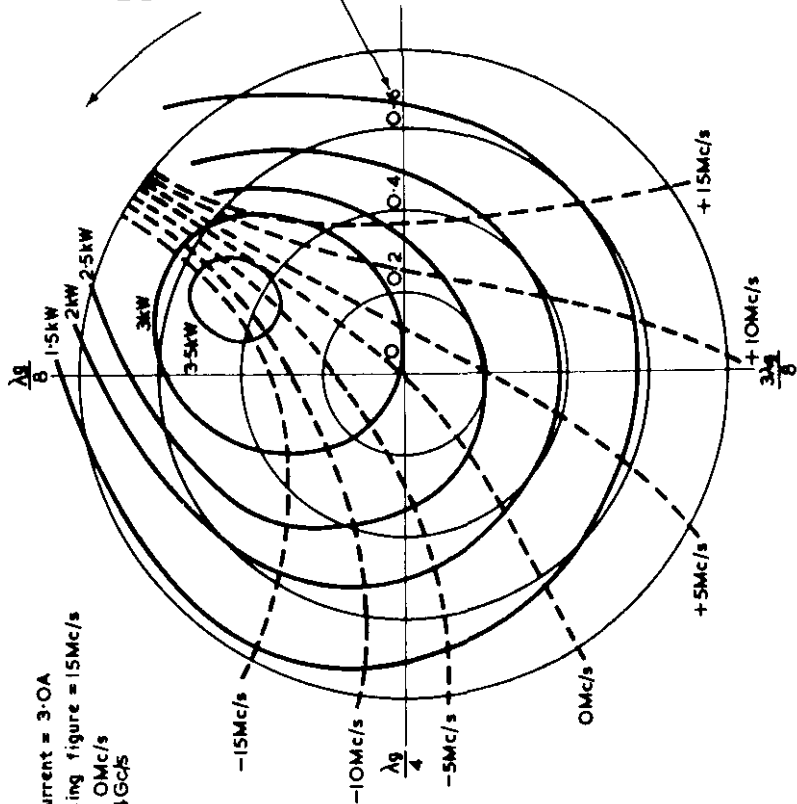

B189B

RIEKE DIAGRAM

MAGNETRON

Frequency: 'X' band, fixed.
 Power output: 7.5kW, pulsed.
 Construction: Packaged, forced-air cooled.

JP9-7
JP9-7A
JP9-7B

This data should be read in conjunction with GENERAL OPERATIONAL RECOMMENDATIONS—MICROWAVE DEVICES: INTRODUCTION and RADAR AND COMMUNICATION MAGNETRONS which precede this section of the handbook.

CHARACTERISTICS

		Min.	Max.	
Frequency (measured with the anode block at 45°C)	JP9-7	9.345	to 9.405	Gc/s
Fixed within the band	JP9-7A	9.210	to 9.270	Gc/s
	JP9-7B	9.525	to 9.585	Gc/s
Pulse voltage ($I_{pulse} = 4.5A$)		5.3	5.7	kV ←
R.F. pulse power output ($I_{pulse} = 4.5A$)		7.0		kW
Frequency pulling factor (v.s.w.r. = 1.5)			15	Mc/s
Frequency temperature coefficient			-0.25	Mc/s per °C
Distance of v.s.w. minimum from face of mounting plate into valve		16.5	22.5	mm ←
Input capacitance			8.0	pF

CATHODE

Indirectly heated

V_h	6.3	V
I_h	600	mA

Heating time. At ambient temperatures above 0°C the cathode must be heated for at least 2 minutes before the application of h.t. Below this temperature the heating time must be increased to at least 3 minutes.

For mean input powers greater than 25 watts, it is necessary to reduce the heater voltage immediately after the application of h.t. in accordance with the input power-heating voltage rating chart on page C2.

TYPICAL OPERATION

Heater voltage (running)	6.3	V
Pulse duration	1.0	μs
Pulse repetition frequency	1000	p/s
Duty cycle	0.001	
Pulse current	4.5	A
Pulse voltage	5.5	kV
R.F. pulse output power	7.5	kW ←
Mean input current	4.5	mA
Mean input power	24.7	W
Mean r.f. output power	7.5	W ←
Frequency pulling (v.s.w.r. = 1.5)	14	Mc/s ←
Rate of rise of pulse voltage	50	kV/μs ←

COOLING

In normal circumstances natural cooling is adequate, but where the ambient temperature is abnormally high a flow of cooling air between the radiator fins may be necessary to keep the block temperature below the permitted maximum.



ABSOLUTE MAXIMUM RATINGS

	<i>Min.</i>	<i>Max.</i>	
Pulse current	3.5	5.5	A
Pulse voltage	5.0	6.0	kV
Pulse duration		2.5	μ s
Duty cycle		0.0025	
Mean input power		82.5	W
Rate of rise of voltage pulse		60	kV/ μ s
Load mismatch (v.s.w.r.)		1.5	
Temperature of anode block		120	$^{\circ}$ C

MOUNTING POSITION

Any

PHYSICAL DATA

Weight of magnetron	$\left\{ \begin{array}{l} 3.0 \\ 1.4 \end{array} \right.$	lb
		kg
Weight of magnetron in carton	$\left\{ \begin{array}{l} 5.7 \\ 2.5 \end{array} \right.$	lb
		kg
Dimensions of storage carton	$\left\{ \begin{array}{l} 7.75 \times 8.0 \times 9.75 \\ 200 \times 210 \times 250 \end{array} \right.$	in
		mm

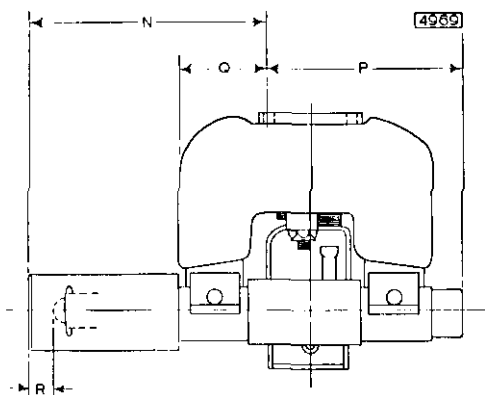

DIMENSIONS

	inches	mm					
A	4.47	113.5	max.	M	1.0	25.4	max.
B	4.103 0.004	104.2 0.1		N	3.19	81.0	max.
C	0.17 0.003	4.32 0.08		P	2.19	55.6	max.
D	0.175 0.003	4.45 0.08		Q	1.19	30.2	max.
E	0.19	4.8	max.	R	0.25	6.4	max.
F	4.0	102	max.	S	0.125 \pm 0.01	3.18 \pm 0.25	
G	1.93	49	min.	T	3.25	82.6	max.
H	1.64	41.7	max.	U	2.52 0.13	64 3	
J	1.22 0.003	30.99 0.08		V	3.0 0.13	76 3	
K	1.22 0.004	30.99 0.1		X	0.400 \pm 0.003	10.16 \pm 0.08	
L	1.28 0.004	32.51 0.1		Y	0.640 \pm 0.004	16.25 0.10	
				Z	0.900 \pm 0.003	22.86 \pm 0.10	



OUTLET VIA WAVEGUIDE WG16
TO TAKE BOLTED FLANGE CHOKE
COUPLING JOINT-SERVICES TYPE 5985-99-083005I

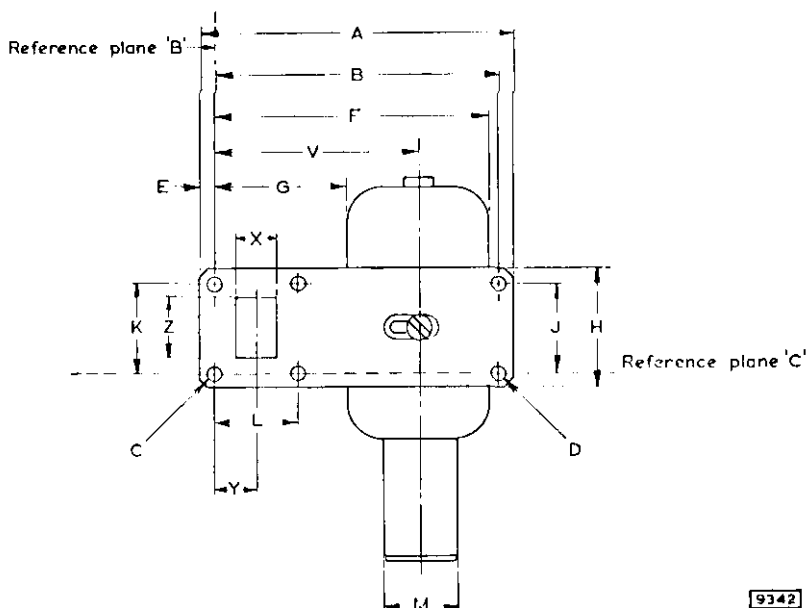
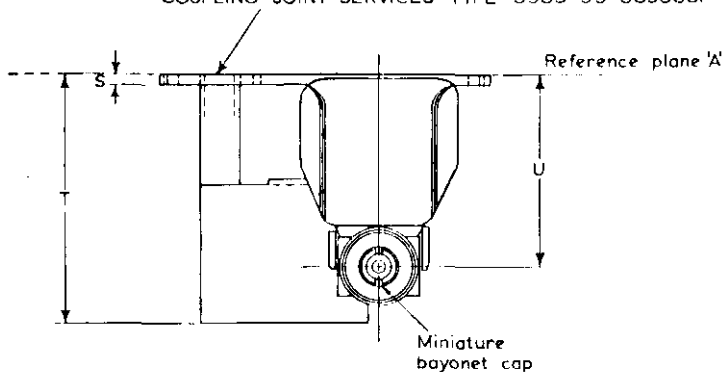

9342

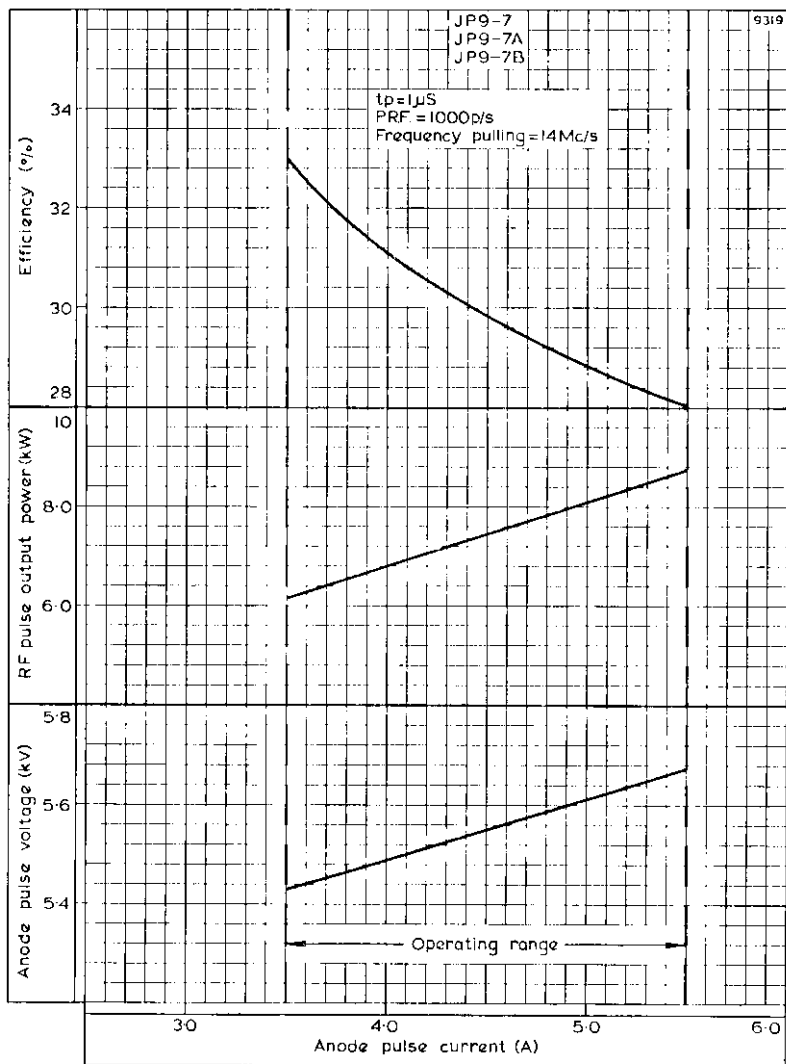

ANODE PULSE VOLTAGE, R.F. PULSE OUTPUT POWER AND EFFICIENCY
 PLOTTED AGAINST ANODE PULSE CURRENT

JP9-7 JP9-7A JP9-7B

MAGNETRON

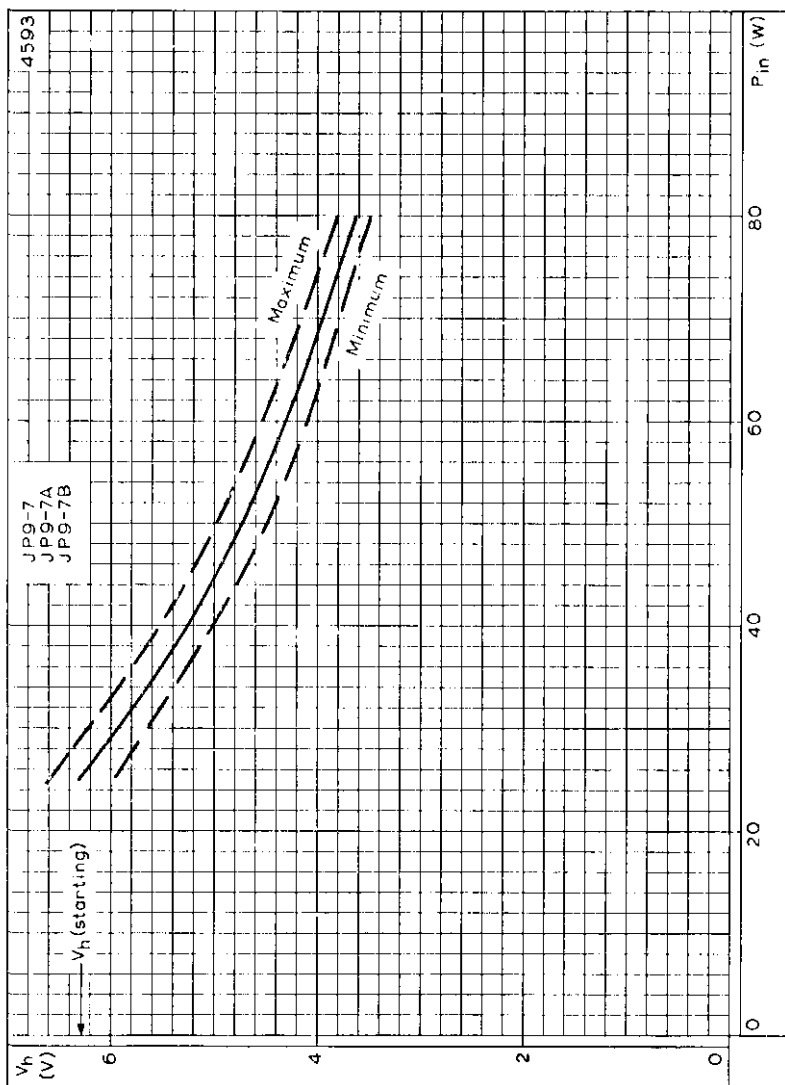

HEATER VOLTAGE PLOTTED AGAINST MEAN INPUT POWER

QUICK REFERENCE DATA

Forced-air cooled fixed frequency 'X' band magnetron.

Frequency	9.375	Gc/s
Power output (pulsed)	10	kW
Construction		Packaged

This data should be read in conjunction with GENERAL OPERATIONAL RECOMMENDATIONS—MICROWAVE DEVICES: INTRODUCTION and RADAR AND COMMUNICATION MAGNETRONS which precede this section of the handbook.

TYPICAL OPERATION

Heater voltage (running)	6.3	6.3	5.8	V
Pulse duration	0.05	0.1	1.0	μ s
Pulse repetition frequency	4000	1000	1000	p/s
Duty cycle	0.0002	0.0001	0.001	
Pulse current	7.0	6.0	5.5	A
Pulse voltage	5.9	5.7	5.6	kV
Pulse input power	41.3	34.2	30.8	kW
R.F. pulse output power	10.5	9.5	9.0	kW
Mean input current	1.4	0.6	5.5	mA
Mean input power	8.3	3.4	31	W
Mean r.f. output power	2.1	0.95	9.0	W
Frequency pulling factor (v.s.w.r. = 1.5)	14	14	14	Mc/s
Rate of rise of pulse voltage	110	110	80	kV/ μ s

ABSOLUTE MAXIMUM RATINGS

	Min.	Max.	
Pulse current			
$t_p < 1.0 \mu$ s	4.5	6.0	A
$t_p < 0.1 \mu$ s	4.5	7.0	A
Pulse duration	0.05	1.0	μ s
Duty cycle	—	0.002	
Mean input power	—	83	W
Rate of rise of voltage pulse	—	120	kV/ μ s
Load mismatch (v.s.w.r.)	—	1.5	
Temperature of anode block	—	100	$^{\circ}$ C

CATHODE

Indirectly heated

V_h	6.3	V
I_h	600	mA

Heating time. At ambient temperatures above 0°C the cathode must be heated for at least 2 minutes before the application of h.t. Below this temperature the heating time must be increased to at least 3 minutes. For mean input powers greater than 25 watts it is necessary to reduce the heater voltage immediately after the application of h.t. in accordance with the input power/heater rating chart on page C2.

CHARACTERISTICS

	Min.	Max.	
Frequency (measured with the anode block at 45°C)			
Fixed within the band	9.345	to 9.405	Gc/s
Pulse voltage ($I_{pulse} = 5.5A$)	5.4	5.9	kV
R.F. pulse output power ($I_{pulse} = 5.5A$)	8.0	—	kW
Frequency pulling factor (v.s.w.r. = 1.5)	—	15	Mc/s
Distance of v.s.w. minimum from mounting plate into valve	16.5	22.5	mm <
Input capacitance	—	8	pF

END OF LIFE PERFORMANCE

R.F. pulse output power ($I_{pulse} = 5.5A$)		7.0	kW <
	Min.	Max.	
Frequency (measured with anode block at 45°C)			
Fixed within the band	9.345	to 9.405	Gc/s
Pulse voltage ($I_{pulse} = 5.5A$)	5.4	5.9	kV

COOLING

In normal circumstances natural cooling is adequate, but where the ambient temperature is abnormally high a flow of cooling air between the radiator pins may be necessary to keep the anode block temperature below the permitted maximum.

MOUNTING POSITION

Any

PHYSICAL DATA

Weight of magnetron	{ 3 lb 0 oz 1.4 kg
Weight of magnetron in carton	{ 5 lb 11 oz 2.5 kg
Dimensions of storage carton	{ 7.75 × 8.0 × 9.75 in 200 × 210 × 250 mm

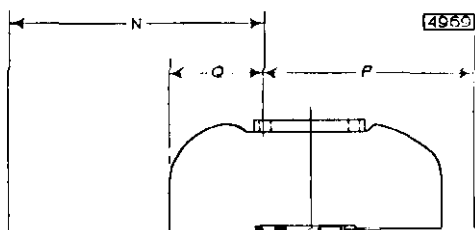

H	1.625 ± 0.016	41.28 ± 0.41	
J	1.22 ± 0.003	30.99 ± 0.08	
K	1.22 ± 0.004	30.99 ± 0.10	
L	1.28 ± 0.004	32.51 ± 0.10	
M	1.0	25.4	max.
N	2.938 ± 0.25	74.61 ± 6.35	
P	2.188	55.6	max.
Q	1.188	30.2	max.
R	0.25	6.4	max.
S	0.125 ± 0.01	3.18 ± 0.25	
T	3.25	82.6	max.
U	2.52 ± 0.13	64 ± 3	
V	3.0 ± 0.13	76 ± 3	
X	0.400 ± 0.003	10.16 ± 0.08	
Y	0.640 ± 0.004	16.25 ± 0.10	
Z	0.900 ± 0.003	22.86 ± 0.10	

OUTLET VIA WAVEGUIDE WG16
TO TAKE BOLTED FLANGE CHOKE
COUPLING INTER-SERVICES TYPE Z830051

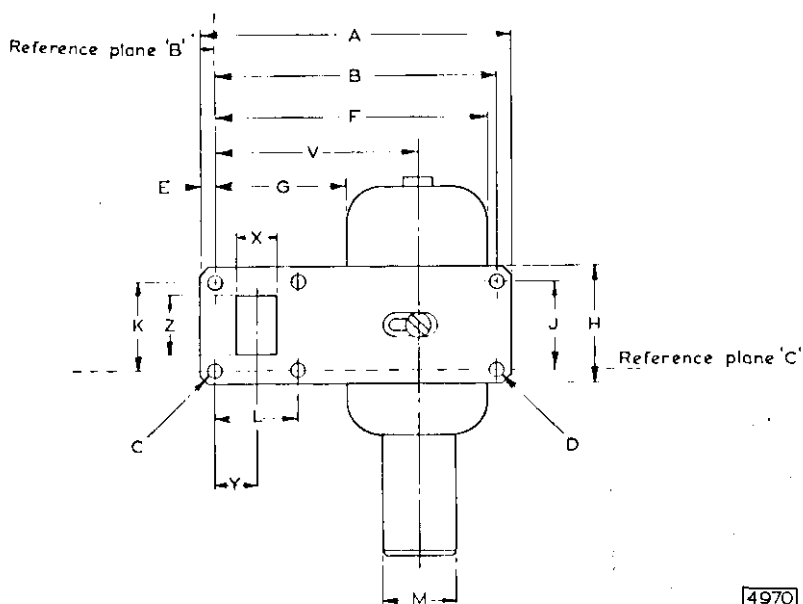
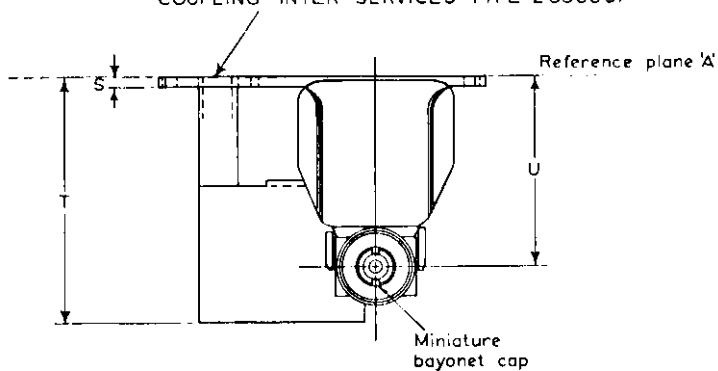

4970

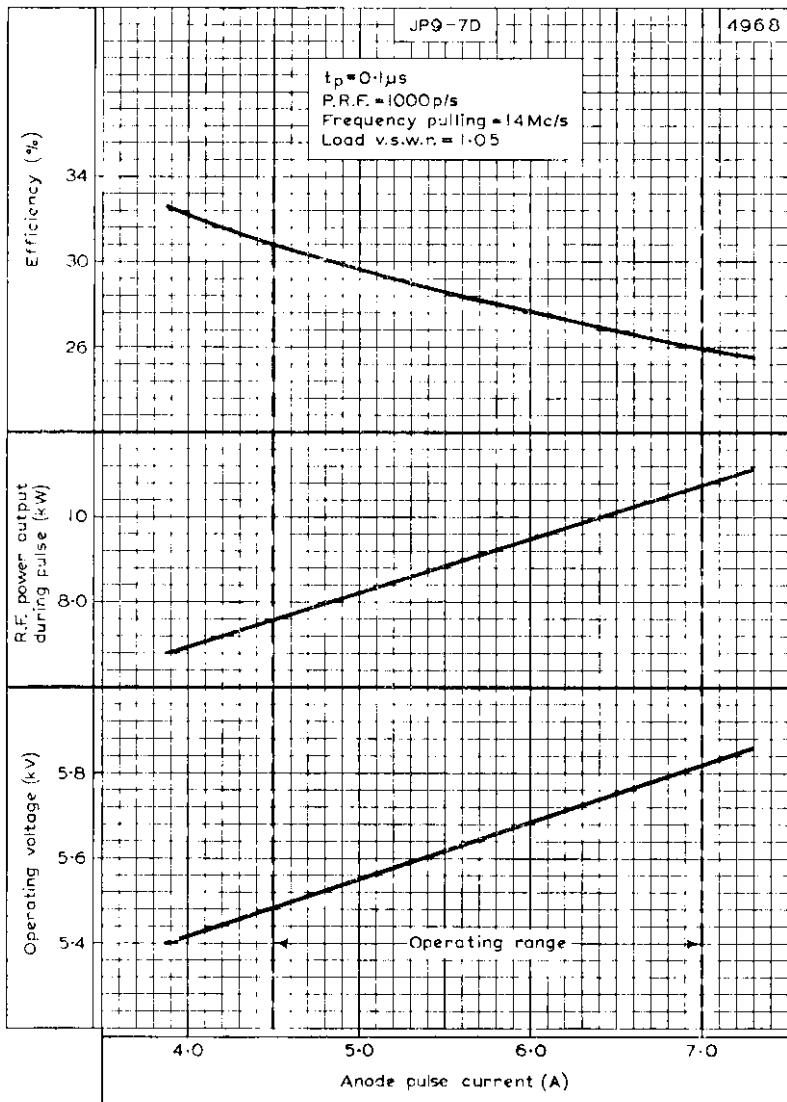

OPERATING VOLTAGE, R.F. POWER OUTPUT DURING PULSE AND EFFICIENCY PLOTTED AGAINST ANODE PULSE CURRENT

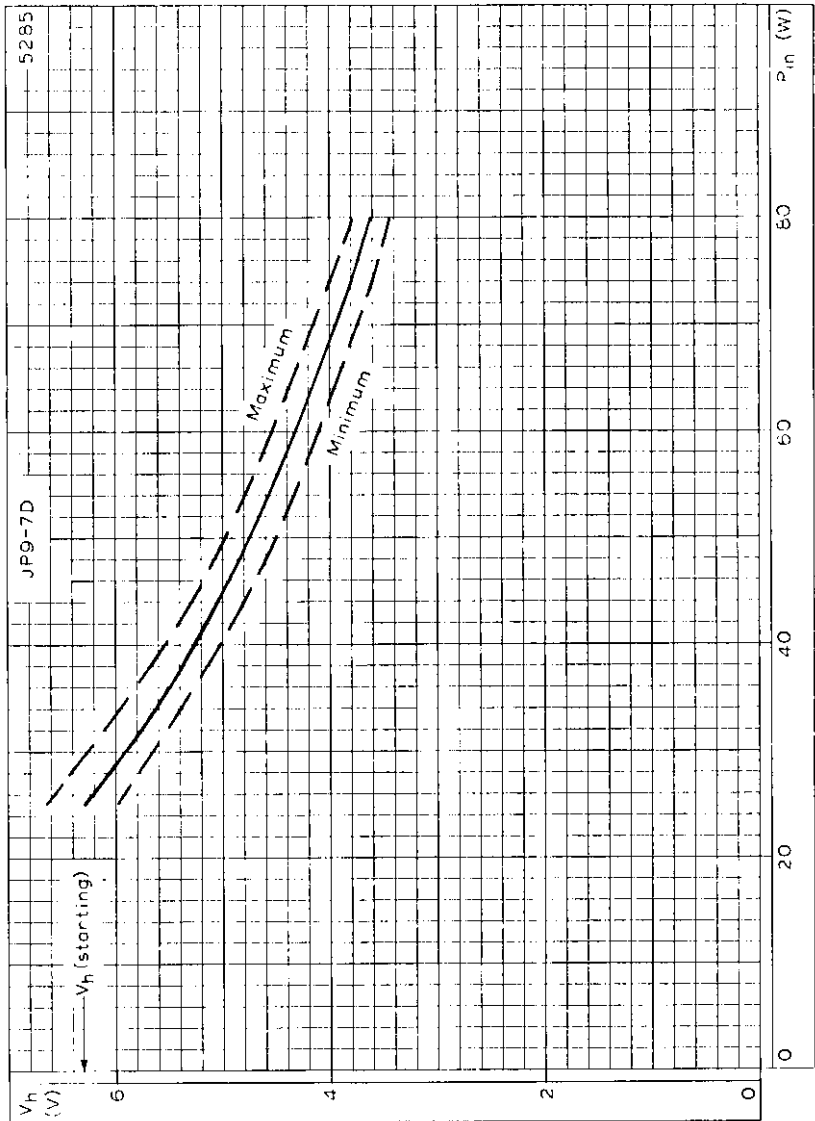

HEATER VOLTAGE PLOTTED AGAINST INPUT POWER

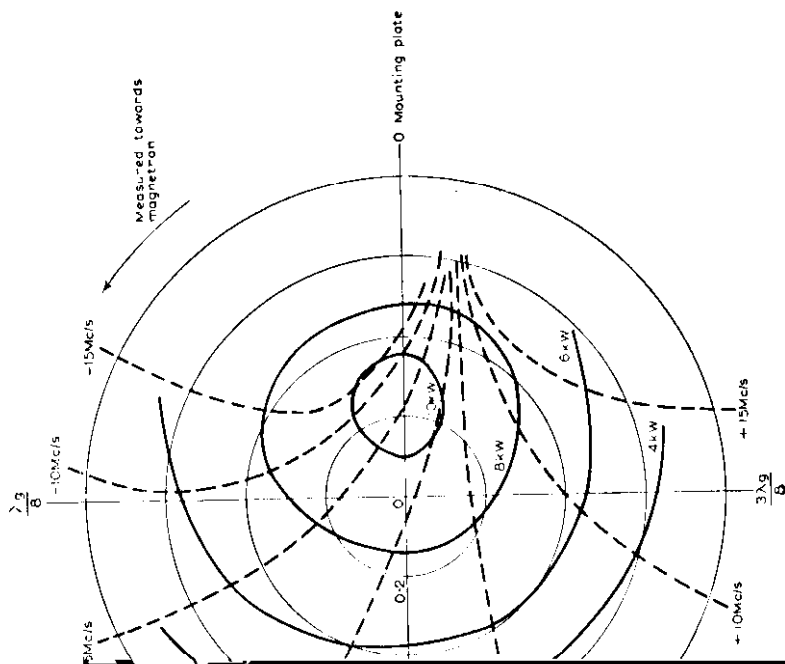

QUICK REFERENCE DATA

Fixed frequency 'X' band magnetron with natural or forced-air cooling.

Frequency JP9-15	9.375 Gc/s
JP9-15B	9.445 Gc/s*
Power output (pulsed)	18 kW
Construction	Packaged

Unless otherwise shown data is applicable to both types.

This data should be read in conjunction with GENERAL OPERATIONAL RECOMMENDATIONS - MICROWAVE DEVICES which precede this section of the handbook.

TYPICAL OPERATION

Pulse duration	0.05	0.1	1.0	μ s
Pulse repetition frequency	2500	2000	500	p/s
Duty cycle	0.000125	0.0002	0.0005	
Pulse current	8.0	7.5	7.0	A
Pulse voltage	7.7	7.6	7.5	kV
Pulse input power	62	57	53	kW
R.F. pulse output power	22	21	20	kW
*Mean input current	1.2	1.6	3.5	mA
Mean input power	7.75	11.4	26.5	W
Mean R.F. output power	2.75	4.2	10.0	W
Heater voltage running	6.3	6.3	6.3	V
Frequency pulling factor (v.s.w.r. = 1.5)	17	17	17	Mc/s
Rate of rise of pulse voltage	95	90	80	kV/ μ s

*Includes pre-oscillation current

ABSOLUTE MAXIMUM RATINGS

Pulse current	Min.	Max.	
($t_p \leq 1.0\mu$ s)	6.0	9.0	A
($t_p > 1.0$ to 2.5μ s)	6.0	7.5	A
Pulse duration	—	2.5	μ s
Duty cycle	—	0.0015	
Mean input power	—	83	W
Rate of rise of voltage pulse	—	100	kV/ μ s
Load mismatch (v.s.w.r.)	—	1.5	
Temperature of anode block	—	120	$^{\circ}$ C

CATHODE

Indirectly heated

V_h	6.3	V
I_h	550	mA

Heating time. At ambient temperatures above 0°C, the cathode must be heated for at least 2 minutes before the application of h.t. Below this temperature the heating time must be increased to at least 3 minutes.

In many applications involving short pulse lengths and high pulse repetition frequencies the mean current which would be calculated from the duty cycle is increased by a pre-oscillation current.

For mean input powers greater than 25 watts, it is necessary to reduce the heater voltage immediately after the application of h.t. in accordance with the input power heater voltage rating chart on page C3.

CHARACTERISTICS

Frequency		Min.	Max.	
Fixed within the band	JP9-15	9.345 to	9.405	Gc/s
	JP9-15B	9.415 to	9.475	Gc/s
Pulse voltage ($I_{pulse} = 7.5A$)		7.0	8.2	kV
R.F. pulse power output ($I_{pulse} = 7.5A$)		17	—	kW
Frequency pulling factor (v.s.w.r. = 1.5)		—	18	Mc/s
Frequency pushing factor		—	1.5	Mc/s per A
Frequency temperature coefficient		—	-250	kc/s per °C
Distance of v.s.w. minimum from face of mounting plate into valve		16.5	22.5	mm
Input capacitance		—	8.0	pF

END OF LIFE PERFORMANCE

R.F. pulse power output ($I_{pulse} = 7.5A$)		15	kW	
Frequency		Min.	Max.	
Within the band	JP9-15	9.345 to	9.405	Gc/s
	JP9-15B	9.415 to	9.475	Gc/s
Pulse voltage ($I_{pulse} = 7.5A$)		7.0	8.2	kV

COOLING

In normal circumstances natural cooling is adequate, but where the ambient temperature is abnormally high, a flow of cooling air between the radiator fins may be necessary to keep the block temperature below the permitted maximum.

MOUNTING POSITION

Any

PHYSICAL DATA

Weight of magnetron	{ 3 lb 11 oz 1.7 kg
Weight of magnetron in carton	{ 6 lb 6 oz 2.9 kg
Dimensions of storage carton	{ 7.8 × 8.0 × 9.8 in 197 × 204 × 248 mm

JP9-15 JP9-15B

MAGNETRON

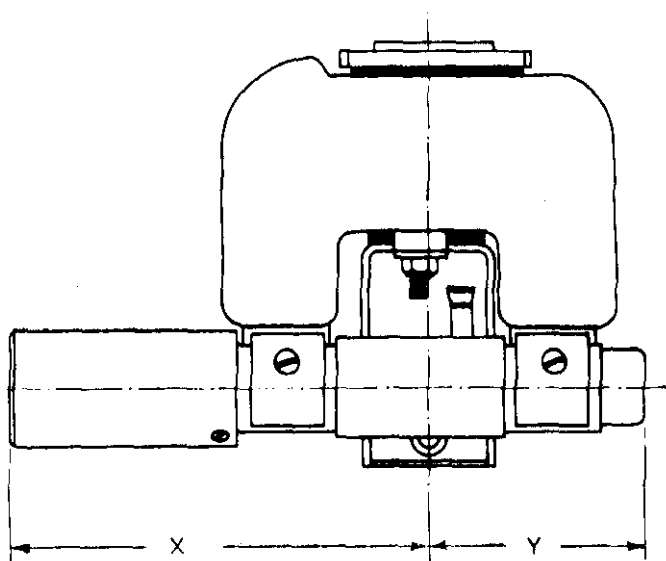

6816

	Inches	Millimetres	
A	4.468	113.5	max.
B	3.465 ± 0.004	88.0 ± 0.1	
C	1.169	29.7	min.
D	0.640 ± 0.004	16.25 ± 0.10	
E	0.400 ± 0.003	10.16 ± 0.08	
F	0.185	4.7	max.
G	1.641	41.7	max.
H	1.800	45.7	max.
J	0.610 ± 0.004	15.5 ± 0.1	
K	0.900 ± 0.004	22.86 ± 0.10	
L	0.170 ± 0.003	4.32 ± 0.08	
M	0.175 ± 0.003	4.45 ± 0.08	
N	0.138	3.5	max.
P	3.500	88.9	max.
Q	2.824	71.74	max.
R	3.358	85.3	max.
S	0.252	6.4	max.
T	1.000	25.4	max.
U	0.591	15	min.
V	2.760	70.1	max.
X	3.799	96.5	max.
Y	1.575	40	max.

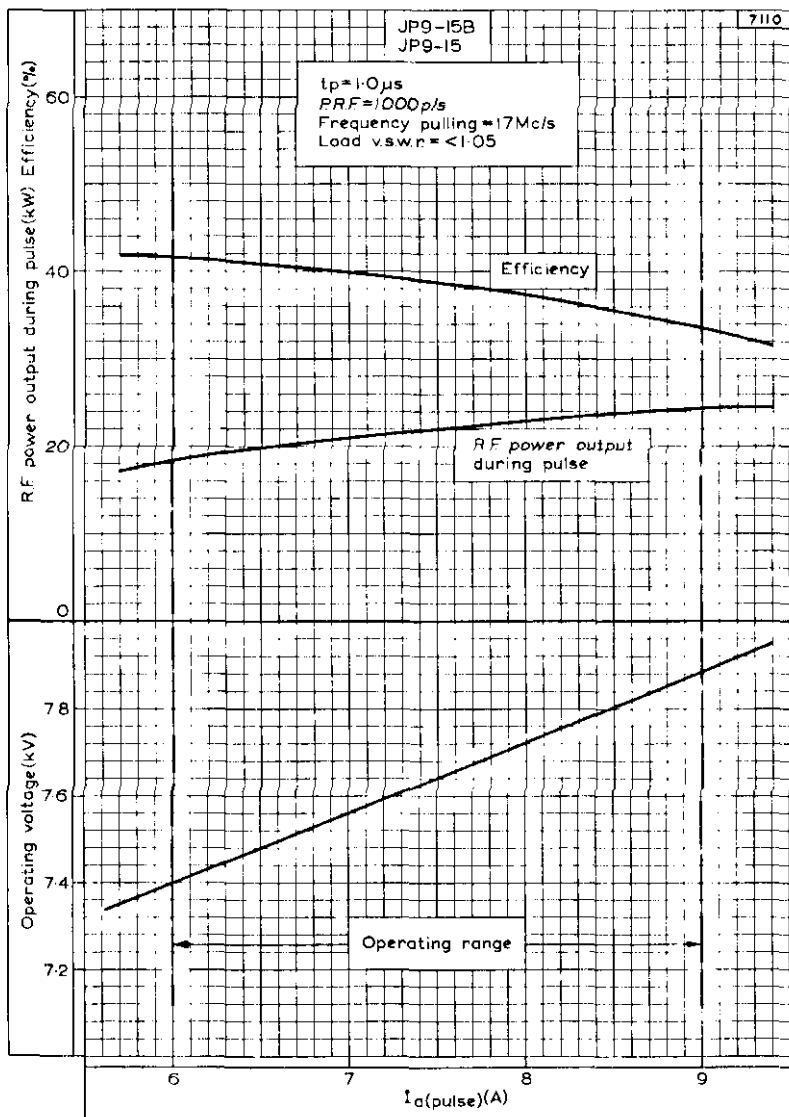

R.F. POWER OUTPUT DURING PULSE, OPERATING VOLTAGE AND EFFICIENCY PLOTTED AGAINST ANODE PULSE CURRENT

JP9-15 JP9-15B

MAGNETRON

JP9-15B
JP9-15

B266B

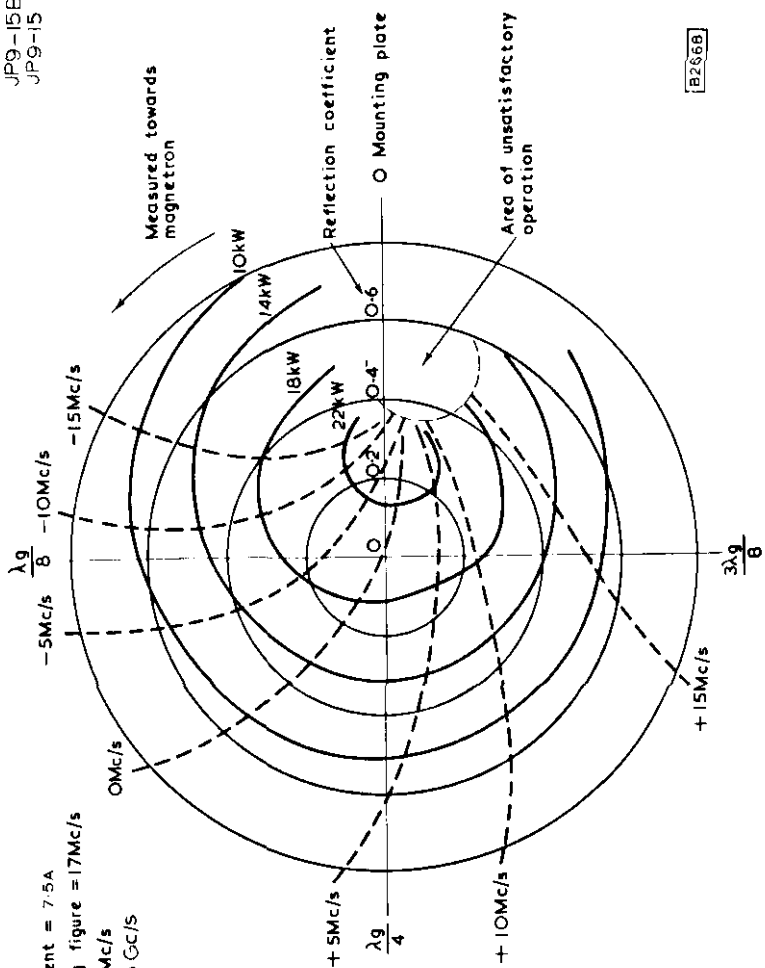

Anode pulse current = 7.5A
 Frequency pulling figure = 17Mc/s
 Frequency of 0Mc/s
 contour = 9.375 Gc/s

RIEKE DIAGRAM



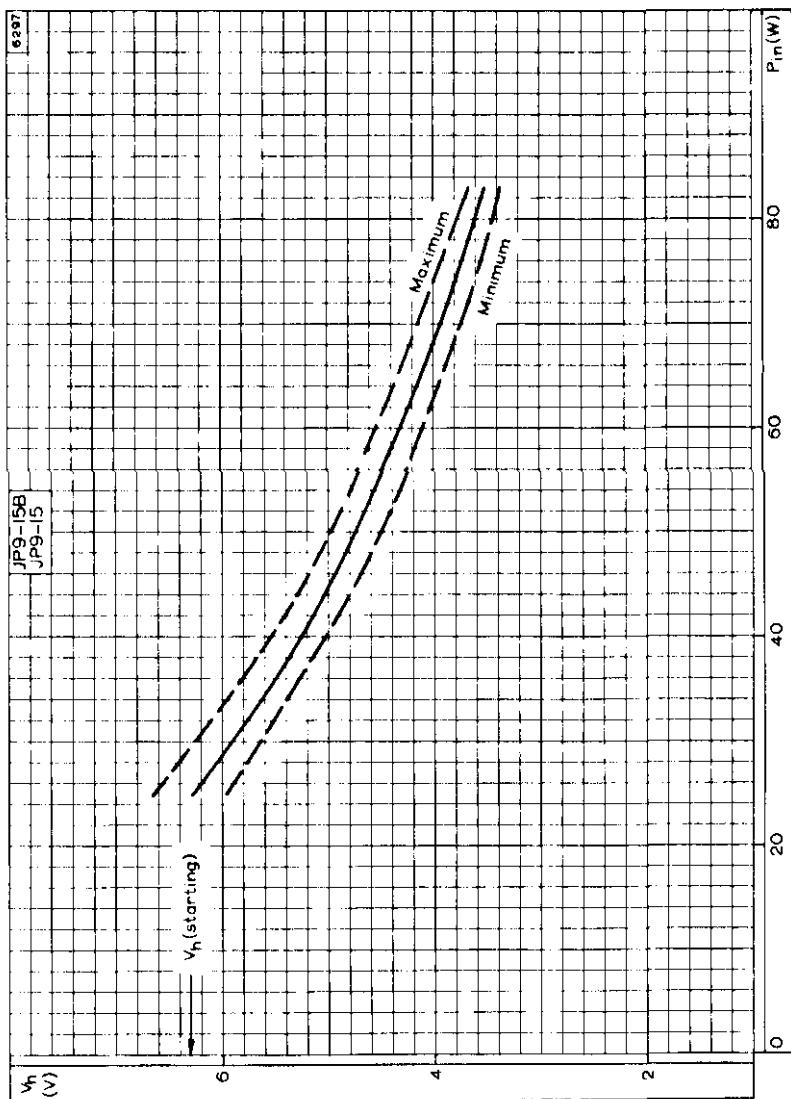

HEATER VOLTAGE PLOTTED AGAINST INPUT POWER

QUICK REFERENCE DATA

Fixed frequency 'X' band magnetron with natural cooling

Frequency	9.41	GHz
Power output (pulsed)	21	kW
Construction		Packaged

To be read in conjunction with
GENERAL OPERATIONAL RECOMMENDATIONS - MICROWAVE DEVICES

OPERATING CONDITIONS

R. F. pulse power output	21	21	kW
Duty factor	0.0002	0.0005	
Pulse duration	0.1	1.0	μ s
Pulse repetition frequency	2000	500	p.p.s.
Heater voltage (running)	6.3	6.3	V
Pulse current	8.6	8.6	A
Pulse voltage	7.2	7.2	kV
Pulse input power	62	62	kW
Rate of rise of voltage pulse	90	90	kV/ μ s
*Mean input current	1.8	4.3	mA
Mean input power	13	31	W
Mean r.f. output power	4.2	10.5	W
Frequency pulling (v.s.w.r. = 1.5)	16	16	MHz

*Includes pre-oscillation current

CHARACTERISTICS

	Min.	Max.	
Frequency fixed within the band	9.38	9.44	GHz
Pulse voltage ($I_{\text{pulse}} = 8.6\text{A}$)	7.0	7.5	kV
R.F. pulse power output ($I_{\text{pulse}} = 8.6\text{A}$)	19	-	kW
Frequency pulling (v.s.w.r. = 1.5)	-	18	MHz
Frequency temperature coefficient	-	-0.25	MHz per degC
Distance for v.s.w. minimum from face of mounting plate into valve	16.5	22.5	mm
Input capacitance	-	8.0	pF
Frequency pushing	-	1.5	MHz per A

RATINGS (ABSOLUTE MAXIMUM SYSTEM)

	Min.	Max.	
Pulse current	7.0	10.	A
Pulse duration	-	2.5	μs
Duty factor	-	0.0015	
Mean input power	-	83	W
Rate of rise of voltage pulse	-	100	kV/ μs
Load mismatch (v.s.w.r.)	-	1.5	

CATHODE

Indirectly heated

V_h	6.3	V
I_h	0.55	A
I_h (surge) max.	5.0	A
r_h (cold)	1.75	Ω

Heating time

At ambient temperatures above 0°C the cathode must be heated for at least 2 minutes before the application of h.t. Below this temperature the heating time must be increased to at least 3 minutes.

In many applications involving short pulse lengths and high pulse repetition frequencies the mean current which would be calculated from the duty cycle is increased by a pre-oscillation current.

For mean input powers greater than 25watts, it is necessary to reduce the heater voltage immediately after the application of h.t. in accordance with the input power-heater voltage rating chart on page C1.

END OF LIFE PERFORMANCE

The valve is deemed to have reached end of life when it fails to satisfy the following:

R. F. pulse power output ($I_{\text{pulse}} = 8.6A$)		17		kW
	Min.		Max.	
Frequency within the band	9.38	to	9.44	GHz
Pulse voltage ($I_{\text{pulse}} = 8.6A$)	7.0	to	7.5	kV

MOUNTING POSITION

Any

PHYSICAL DATA

	kg	lb
Weight of magnetron	1.7	3.7
Weight of magnetron in carton	2.9	6.4
	cm	in
Dimensions of storage carton	19.7 × 20.4 × 24.8	7.8 × 8.0 × 9.8

COOLING

In normal circumstances natural cooling is adequate, but where the ambient temperature is abnormally high, a flow of cooling air between the radiator fins may be necessary to keep the anode block temperature below the permitted maximum.

Temperature

Anode block max.	120	°C
------------------	-----	----

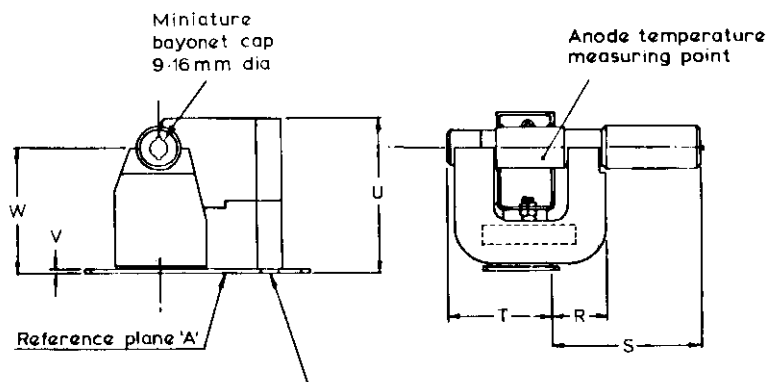
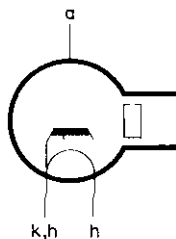
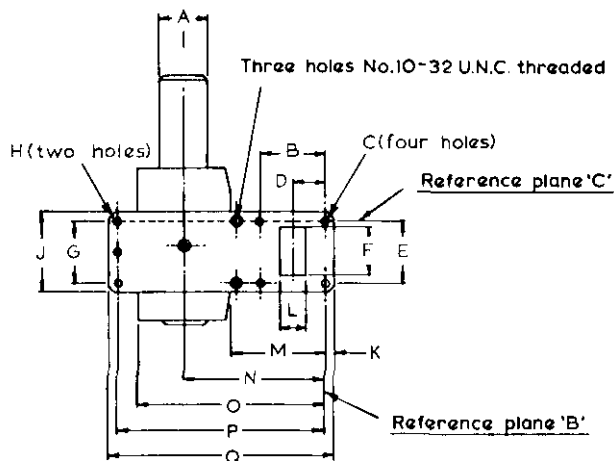

Outlet via WG16(R100,WR90) to take bolted flange choke coupling Joint Services type 5985-99-083-0051

DIMENSIONS

	Millimetres	Inches	
A	25.40	1.000	dia. max.
B	32.51 ± 0.10	1.280 ± 0.004	
C	4.32 ± 0.08	0.170 ± 0.003	dia.
D	16.25 ± 0.10	0.640 ± 0.004	
E	30.99 ± 0.08	1.220 ± 0.003	
F	22.86 ± 0.10	0.900 ± 0.004	
G	30.99 ± 0.08	1.220 ± 0.003	
H	4.445 ± 0.075	0.175 ± 0.003	dia.
J	41.70	1.641	max.
K	4.80	0.189	max.
L	10.16 ± 0.08	0.400 ± 0.003	
M	47.00	1.850	min.
N	76 ± 3.0	3.0 ± 0.12	
O	102	4.015	max.
P	104.2 ± 0.10	4.10 ± 0.004	
Q	113.5	4.468	max.
R	28.00	1.10	max.
S	78.00	3.07	max.
T	55.00	2.165	max.
U	84.00	3.307	max.
V	3.18 ± 0.25	0.125 ± 0.0098	
W	65 ± 3.0	2.56 ± 0.12	

Inch dimensions derived from original millimetre dimensions

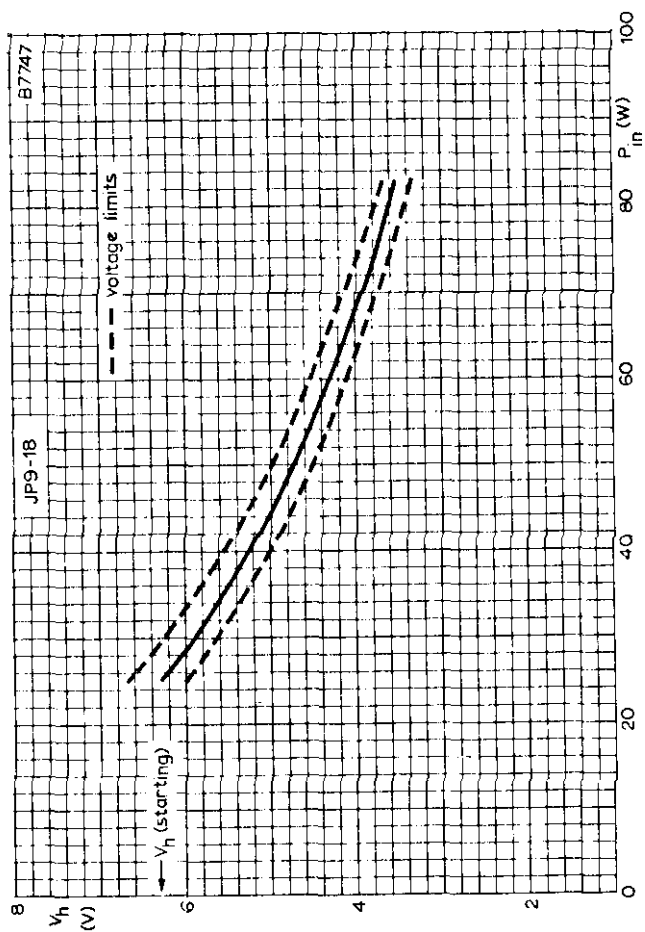

HEATER DERATING CHART

MAGNETRON

Frequency: 'X' Band, fixed.
Power Output: 50kW, pulsed.
Construction: Packaged, forced-air cooled.

JP9-50 JP9-50A

This data should be read in conjunction with GENERAL OPERATIONAL RECOMMENDATIONS - MICROWAVE DEVICES: INTRODUCTION and RADAR AND COMMUNICATION MAGNETRONS which precede this section of the handbook

CHARACTERISTICS

Frequency	Min.	Max.	
Fixed within the band JP9-50	9.215	9.275	Gc/s
JP9-50A	9.345	9.405	Gc/s
Pulse voltage ($I_{\text{pulse}} = 12\text{A}$)	—	13.5	kV
R.F. pulse power output ($I_{\text{pulse}} = 12\text{A}$)	40	—	kW
Frequency pulling factor (v.s.w.r. = 1.5)	—	15	Mc/s
Frequency temperature coefficient	—	-0.25	Mc/s per °C
Input capacitance	—	9.5	pF

CATHODE

Indirectly heated

V_{h}	6.3	V
I_{h}	1.0	A
$I_{\text{h(surge) max.}}$	6.0	A
r_{h} (cold)	0.8	Ω

Heating time. The cathode must be heated for at least 2 minutes before the application of h.t.

It is necessary to reduce the heater voltage immediately after the application of h.t. in accordance with the input power-heater voltage rating chart on page C2.

TYPICAL OPERATION

Heater voltage (running)	5.0	0	V
Pulse duration	0.1	1.0	μs
Pulse repetition frequency	3300	1000	p/s
Duty cycle	0.00033	0.001	
Pulse current	12	12	A
Pulse voltage	12.7	12.7	kV
Pulse input power	152	152	kW
R.F. pulse output power	50	50	kW
Mean input current	4.0	12	mA
Mean input power	50	152	W
Mean r.f. output power	16.5	50	W
Frequency pulling (v.s.w.r. = 1.5)	12	12	Mc/s
Voltage pulse rise time	0.08	0.08	μs

COOLING

It is necessary to direct a flow of cooling air between the radiator fins, and on the cathode and heater seals, in order to keep the temperature below the permitted maximum

JP9-50

JP9-50A

MAGNETRON

ABSOLUTE MAXIMUM RATINGS

	Min.	Max.	
Pulse current	6.0	15	A
Pulse duration	—	2.5	μ s
Duty cycle	—	0.001	
Mean input power	—	180	W
Voltage pulse rise time	0.05	0.25	μ s
Load mismatch (v.s.w.r.)	—	1.5	
Temperature of anode block	—	100	$^{\circ}$ C
Pressurisation of waveguide output	} 520 10	—	torr
			lb/in ²
Pressurisation of circular mounting flange	} — —	2224	torr
			43

MOUNTING POSITION

Any

PHYSICAL DATA

Weight of magnetron	} 3.7 1.7	lb
		kg
Weight of magnetron in carton	} 9.9 4.5	lb
		kg

DIMENSIONS

	Inches	Millimetres	
A	2.50	63.5	max.
B	0.437 \pm 0.020	11.1 \pm 0.5	
C	0.0850 \pm 0.0051	2.16 \pm 0.13	
D	1.42	36	max.
E	1.24	31.6	
F	0.1929 \pm 0.0028	4.90 \pm 0.07	dia.
G	1.187	30.15	
H	1.437 \pm 0.028	36.5 \pm 0.7	
J	1.687	42.85	
K	2.8740 \pm 0.0051	73.0 \pm 0.13	
L	5.373	136.5	max.
M	0.5	12.7	max.
N	0.063	1.6	
O	3.12	79.3	max.
P	1.34	34	rad.
Q	0.37	9.5	
R	2.74	69.7	max.
S	2.66	67.6	max.
T	1.7500 \pm 0.0071	44.45 \pm 0.18	
U	2.06	52.2	max.
V	1.192 \pm 0.020	30.3 \pm 0.5	
W	0.43	11	min.
X	2.97	75.4	max.
Y	0.75	19	
Z	1.563 \pm 0.020	39.7 \pm 0.5	
AA	0.1254 \pm 0.0051	3.18 \pm 0.13	
BB	2.984 \pm 0.063	75.8 \pm 1.6	
CC	3.248 \pm 0.028	82.5 \pm 0.7	

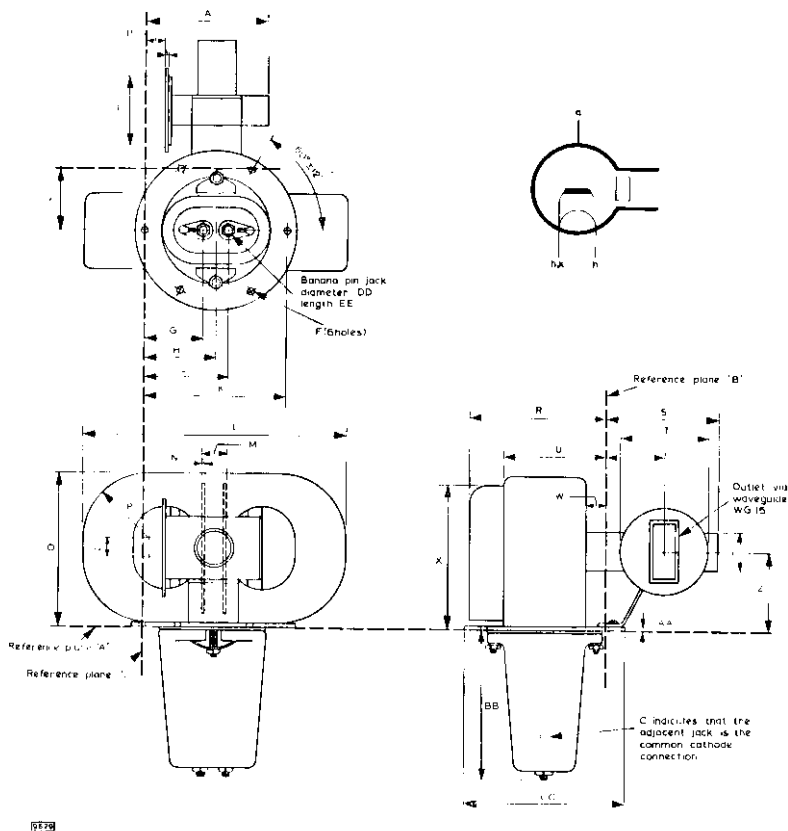

ANODE CONNECTION TERMINATED AT THE BASE PLATE

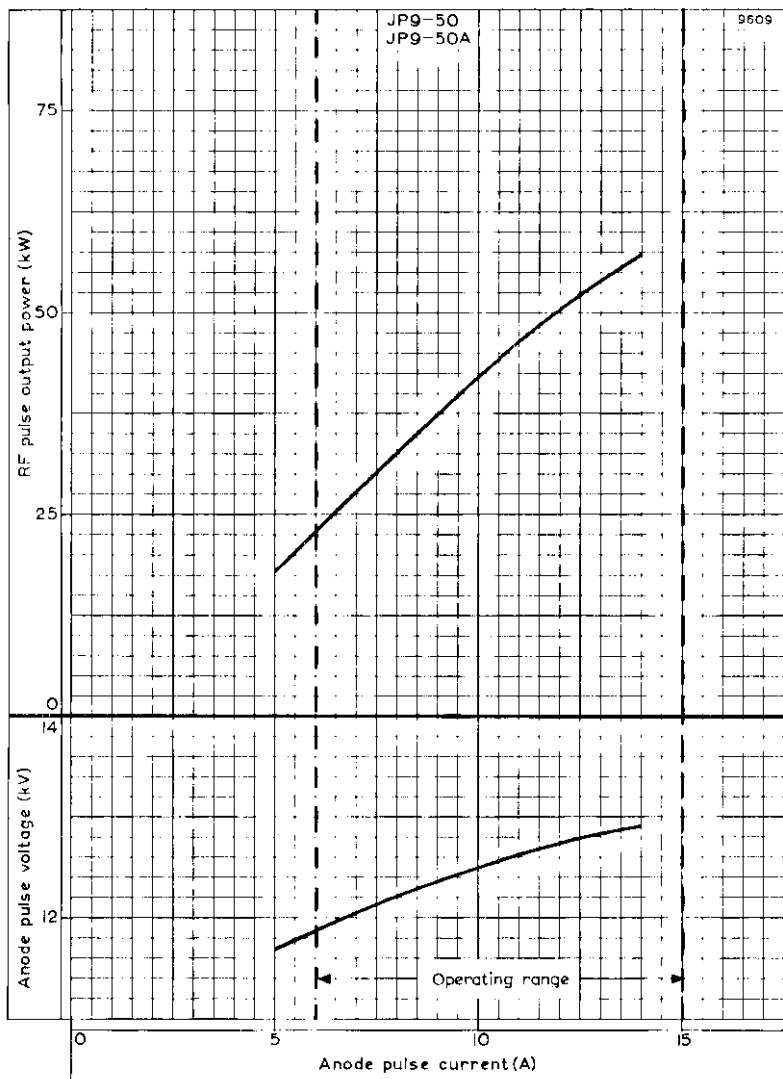

ANODE PULSE VOLTAGE AND R.F. PULSE OUTPUT POWER PLOTTED AGAINST ANODE PULSE CURRENT

JP9-50 JP9-50A

MAGNETRON



HEATER VOLTAGE PLOTTED AGAINST MEAN INPUT POWER

QUICK REFERENCE DATA

Forced-air cooled fixed frequency 'X' band pulsed magnetron

Frequency JP9-75	9.375 Gc/s
JP9-75B	9.445 Gc/s
Power output (pulsed)	80 kW
Construction	Packaged

Unless otherwise shown, data are applicable to both types.

This data should be read in conjunction with GENERAL OPERATIONAL RECOMMENDATIONS - MICROWAVE DEVICES which precede this section of the handbook.

CHARACTERISTICS

	Min.		Max.	
Frequency				
Fixed within the band JP9-75	9.345	to	9.405	Gc/s
JP9-75B	9.415		9.475	Gc/s
Pulse voltage ($I_{\text{pulse}} = 15\text{A}$)	14		16	kV
R.F. pulse output power ($I_{\text{pulse}} = 15\text{A}$)	65		—	kW
Frequency pulling factor (v.s.w.r. = 1.5)	—		15	Mc/s
Frequency pushing factor	—		750	kc/s per A
Frequency temperature coefficient	—		-250	kc/s per °C
Distance of v.s.w. minimum from face of mounting plate into valve	10.8	to	17.8	mm
Input capacitance	—		12	pF

TYPICAL OPERATION

Duty cycle	0.0002	0.001	0.001	
Heater voltage (running)	10	7.5	7.5	V
Pulse duration	0.1	1.0	5.0	μs
Pulse repetition frequency	2000	1000	200	p/s
Pulse current	15	15	15	A
Pulse voltage	15	15	15	kV
Pulse input power	225	225	225	kW
R.F. pulse output power	80	80	80	kW
*Mean input current	3.5	15	15	mA
Mean input power	45	225	225	W
Mean r.f. output power	16	80	80	W
Frequency pulling (v.s.w.r. = 1.5)	10	10	10	Mc/s
Rate of rise of pulse voltage	140	70	60	kV/μs

*Includes pre-oscillation current

JP9-75 JP9-75B

MAGNETRON

CATHODE

Indirectly heated

V_h	10	V
I_h	2.85	A
$I_{h(\text{surge}) \text{ max.}}$	11.5	A
r_h (cold)	0.4	Ω

Heating time. At ambient temperatures above 0°C the cathode must be heated for at least 3 minutes before the application of h.t.

In many applications involving short pulse lengths and high pulse repetition frequencies the mean current which would be calculated from the duty cycle is increased by the pre-oscillation current.

For mean input powers greater than 50 watts, it is necessary to reduce the heater voltage immediately after the application of h.t. in accordance with the input power-heater voltage rating chart on page C2.

ABSOLUTE MAXIMUM RATINGS

	Min.	Max.	
Pulse current	11	17	A
Pulse duration	—	5.5	μs
Duty cycle	—	0.002	
Mean input power	—	400	W
Rate of rise of voltage pulse			
($t_r \leq 1\mu\text{s}$)	—	150	kV/ μs
($t_r > 1\mu\text{s}$)	—	80	kV/ μs
Load mismatch (v.s.w.r.)	—	1.5	
Temperature of anode block	—	175	°C
Temperature of cathode and heater seals	—	150	°C

END OF LIFE PERFORMANCE

The valve is deemed to have reached end of life when it fails to satisfy the following:—

R.F. pulse power output ($I_{\text{pulse}} = 15\text{A}$)		60	kW
Frequency	Min	Max	
JP9-75	9.345 to	9.405 Gc/s	
Within the band JP9-75B	9.415 to	9.475 Gc/s	
Pulse voltage ($I_{\text{pulse}} = 15\text{A}$)	14	to 16	kV

MOUNTING POSITION

Any

PRESSURISING

The valve must not be operated at a pressure lower than 600mm of mercury. The waveguide output system can be pressurised up to a pressure of 2370mm of mercury.

PHYSICAL DATA

	lb	kg
Weight of magnetron	4.7	2.2
Weight of magnetron in carton	13	5.9
	in	cm
Dimensions of storage carton	13.25 x 12 x 9.375	33.7 x 30.5 x 23.8

COOLING

It is necessary to direct a flow of cooling air between the radiator fins, and on the cathode and heater seals, in order to keep the temperature below the permitted maximum.

→ DIMENSIONS

	Inches	Millimetres	
A	0.157	4.0	min.
B	0.276	7.0	min.
C	0.932 ± 0.014	23.65 ± 0.35	
D	0.470 ± 0.010	11.95 ± 0.25	
E	0.323 ± 0.008	8.2 ± 0.2	
F	3.150	80	max.
G	0.787 ± 0.024	20 ± 0.6	
H	1.220 ± 0.004	31 ± 0.1	
J	1.280 ± 0.004	32.5 ± 0.1	
K	0.197 ± 0.118	5.0 ± 3.0	
L	1.969 ± 0.079	50 ± 2.0	
M	1.870 ± 0.098	47.5 ± 2.5	
N	0.787 ± 0.079	20 ± 2.0	
O	1.412	29	max.
P	0.626 ± 0.024	15.9 ± 0.6	
Q	1.260 ± 0.039	32 ± 1.0	
R	3.189	81	max.
S	2.874	73	max.
T	0.630 ± 0.079	16 ± 2.0	
X	0.551	14	max.
Y	2.783 ± 0.012	70.7 ± 0.3	
Z	5.945	151	max.
AA	2.531 ± 0.010	64.29 ± 0.25	
AB	3.622	92	max.
AC	1.969	50	max.
AD	0.281 ± 0.005	7.14 ± 0.12	

Inch dimensions derived from original millimetre dimensions.

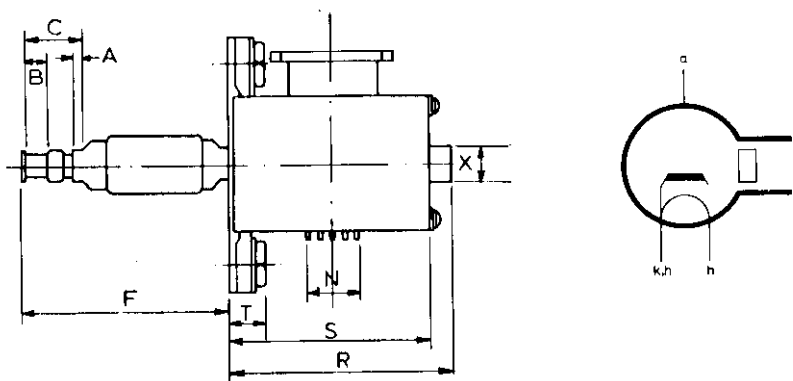
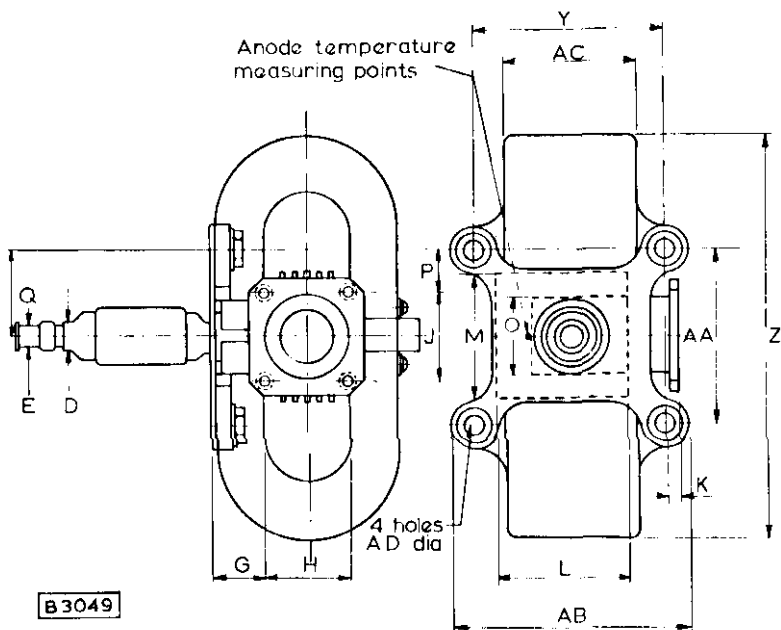

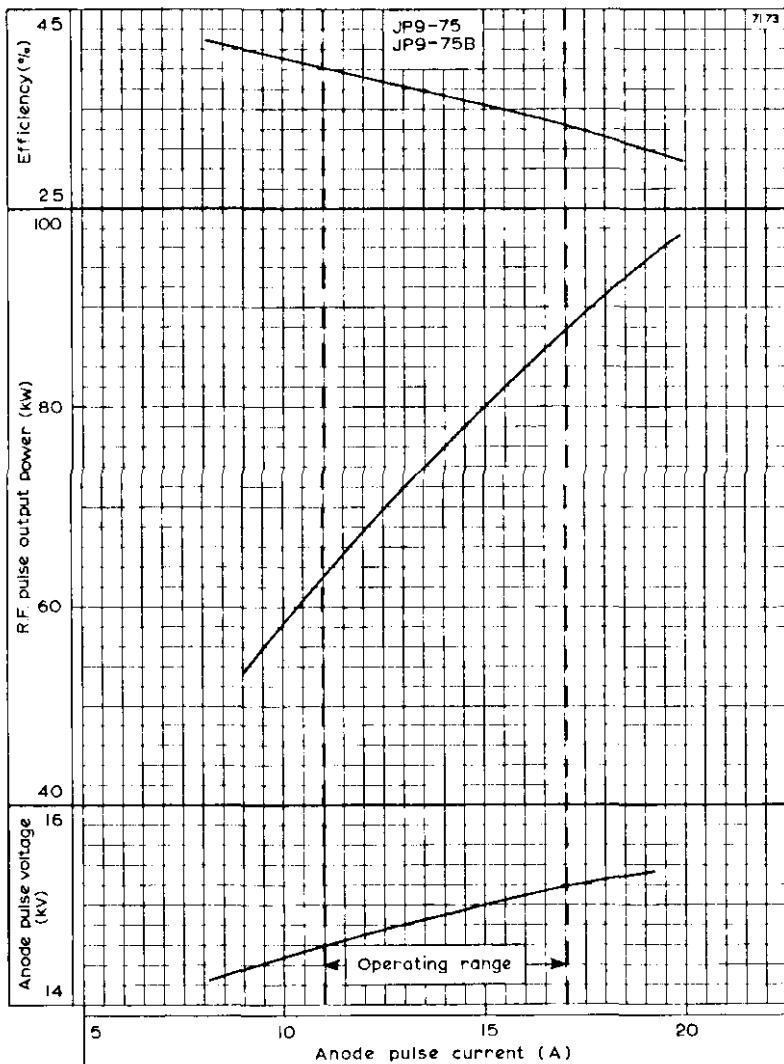

ANODE PULSE VOLTAGE, R.F. PULSE OUTPUT POWER AND EFFICIENCY
PLOTTED AGAINST ANODE PULSE CURRENT

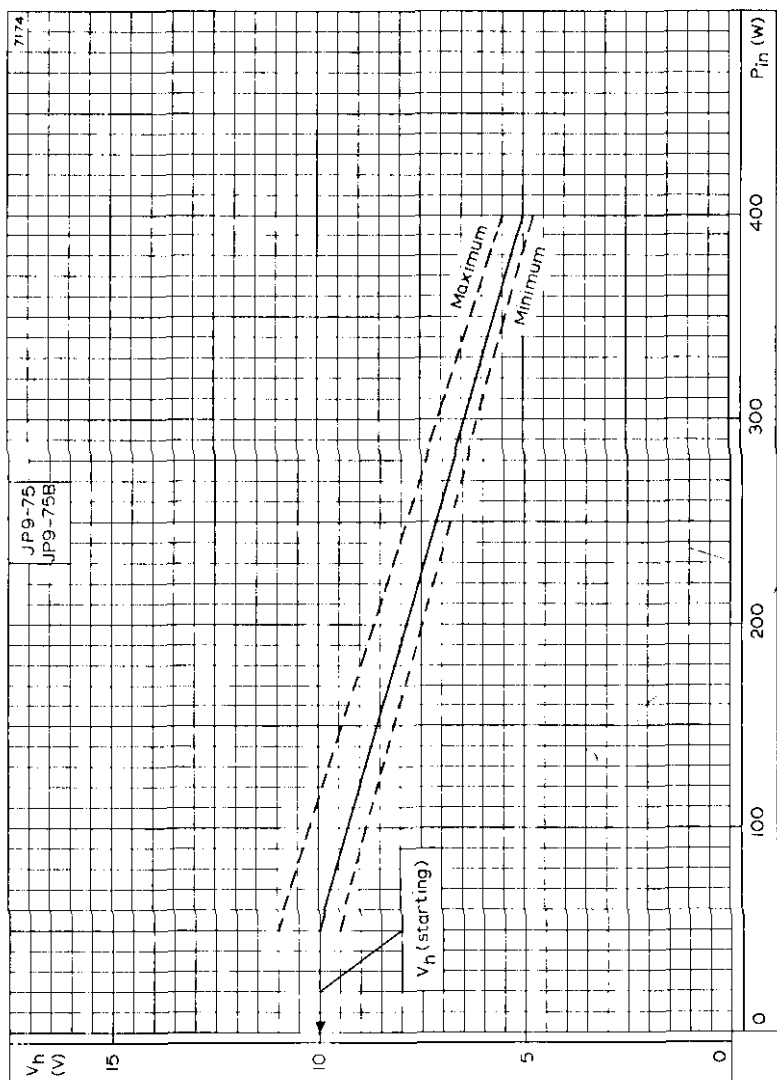

REDUCTION OF HEATER VOLTAGE PLOTTED AGAINST MEAN INPUT POWER

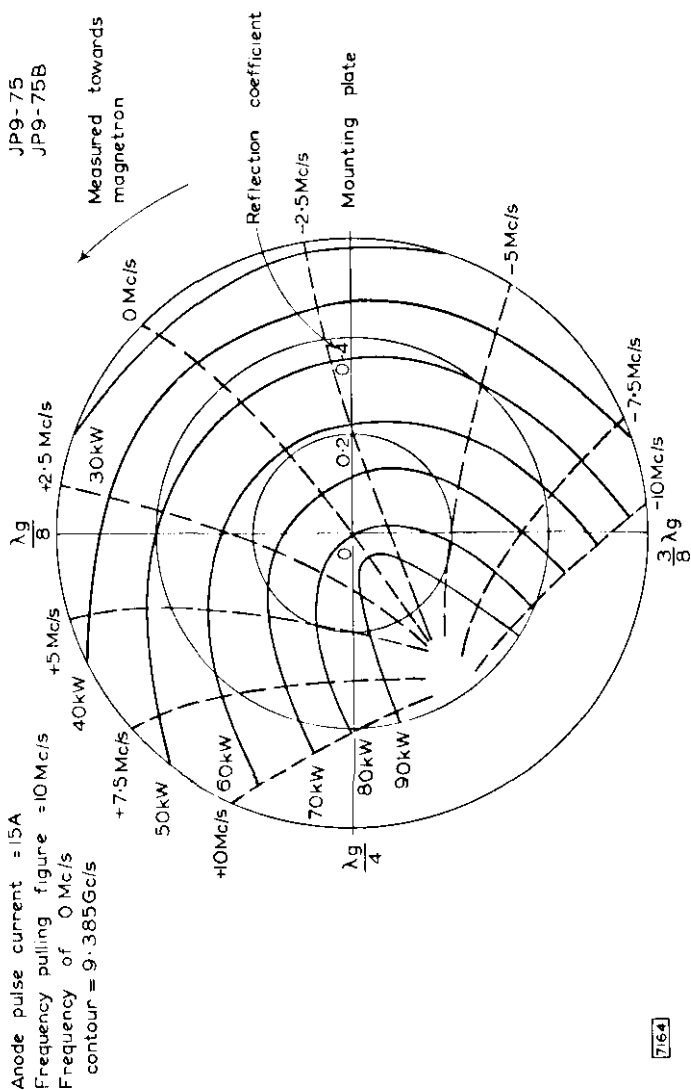

RIEKE DIAGRAM

7164

QUICK REFERENCE DATA

Forced-air cooled fixed frequency 'X' band pulsed magnetron.

Frequency JP9-80	9.375	Gc/s
Frequency JP9-80A	9.240	Gc/s
Power output (pulsed)	80	kW

To be read in conjunction with GENERAL OPERATIONAL RECOMMENDATIONS - MICROWAVE DEVICES.

Unless otherwise shown, data are applicable to both types.

CHARACTERISTICS

	Min.		Max.	
Frequency JP9-80	9.345	to	9.405	Gc/s
Fixed within the band JP9-80A	9.210	to	9.270	Gc/s
Pulse voltage (1 pulse = 15 A)	14		16	kV
R. F. pulse power output (1 pulse = 15A)	70		-	kW
Frequency pulling (v. s. w. r. = 1.5)	-		13	Mc/s
Frequency temperature coefficient	-		-0.25	Mc/s per °C
Position of phase of sink from face of mounting plate towards load	0.26	to	0.40	λg
Input capacitance	-		14	pF
Frequency pushing (12A to 15A)	-		0.5	Mc/s per A

TYPICAL OPERATION

R. F. pulse power output	80	80	80	kW
Duty factor	0.0008	0.001	0.001	
Pulse duration	0.4	1.0	5.0	μs
Pulse repetition frequency	2000	1000	200	p. p. s.
Heater voltage (running)	8.5	7.8	7.8	V
Pulse current	15	15	15	A
Pulse voltage	15	15	15	kV
Pulse input power	225	225	225	kW
Rate of rise of voltage pulse	140	125	85	kV/μs
Mean input current	12	15	15	mA
Mean input power	180	225	225	W
Mean r. f. output power	64	80	80	W
Frequency pulling (v. s. w. r. = 1.5)	12	12	12	Mc/s



CATHODE

Indirectly heated

V _h	12.6	V
I _h	2.2	A
r _h (cold)	0.65	Ω
I _h (surge) max.	10	A
Minimum warm up time	90	s

It is necessary to reduce the heater voltage immediately after the application of h.t. in accordance with the input power - heater voltage rating chart on page C2.

ABSOLUTE MAXIMUM RATINGS

	Min.	Max.	
Pulse current	12	15	A
Pulse duration	-	5.0	μs
Duty factor	-	0.001	
Mean input power	-	240	W
Rate of rise of voltage pulse			
t _p 0.4 μs	120	160	kV/μs
t _p 1.0 μs	100	150	kV/μs
t _p 4.5 μs	70	100	kV/μs
Load mismatch (v. s. w. r.)	-	1.5	
Temperature of anode block	-	150	°C
Temperature of cathode and heater seals	-	175	°C

END OF LIFE PERFORMANCE

The valve is deemed to have reached end of life when it fails to satisfy the following :-

R. F. pulse power output (I pulse = 15A) 60 kW

	Min.	Max.	
Frequency			
Within the band JP9-80	9.345 to	9.405	Gc/s
JP9-80A	9.210 to	9.270	Gc/s
Pulse voltage (I pulse = 15A)	14 to	16	kV

MOUNTING POSITION

Any

PRESSURISING

The valve can be operated in the pressure range 500 to 2,050mm of mercury.



PHYSICAL DATA

	lb	kg
Weight of magnetron	5.875	2.7
Weight of magnetron in carton	14.625	6.7
	in	cm
Dimensions of storage carton	7.5 x 8.7 x 10	19.1 x 22.3 x 25.4

COOLING

It is necessary to direct a flow of cooling air between the radiator fins, and on the cathode and heater seals, in order to keep the temperature below the permitted maximum.

DIMENSIONS

	Inches	Millimetres	
A	3.437	87.3	max
B	2.531 \pm 0.010	64.29 \pm 0.25	
C	0.281 \pm 0.005	7.14 \pm 0.12	
D	1.016 \pm 0.024	25.8 \pm 0.6	
E	3.622	92	max
F	1.937	49.2	max
G	2.781 \pm 0.010	70.64 \pm 0.25	
H	1.874	47.6	min
J	5.937	150.8	max
K	1.831	46.5	
L	1.474 \pm 0.004	37.44 \pm 0.1	
M	3.154	80.1	max
N	2.843	72.2	max
P	1.406 \pm 0.020	35.71 \pm 0.5	
Q	0.497	12.62	
R	1.122	28.5	
S	1.352 \pm 0.004	34.34 \pm 0.1	
T	1.831	46.5	
U	2.156 \pm 0.061	54.75 \pm 1.55	
V	1.126	28.6	
W	0.520	13.2	min
X	0.125	3.17	
Y	0.752	19.1	min
Z	0.156 \pm 0.030	3.95 \pm 0.75	
AA	0.169 \pm 0.005	4.29 \pm 0.12	
BB	0.126 \pm 0.008	3.2 \pm 0.2	
CC	0.201	5.1	max
DD	0.250 \pm 0.014	6.35 \pm 0.35	
EE	0.539 \pm 0.006	13.68 \pm 0.16	
FF	0.610	15.5	
GG	0.748	19	
HH	0.831 \pm 0.006	21.12 \pm 0.16	

7091

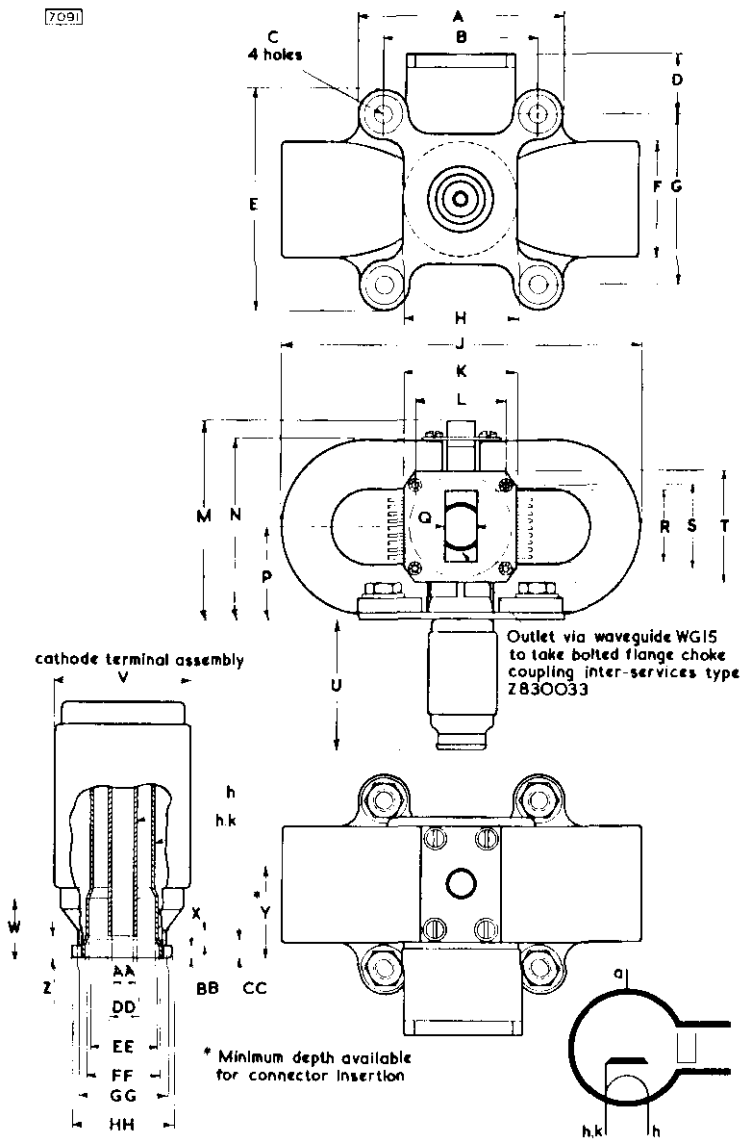

THE ANODE IS TERMINATED AT THE BASE PLATE.

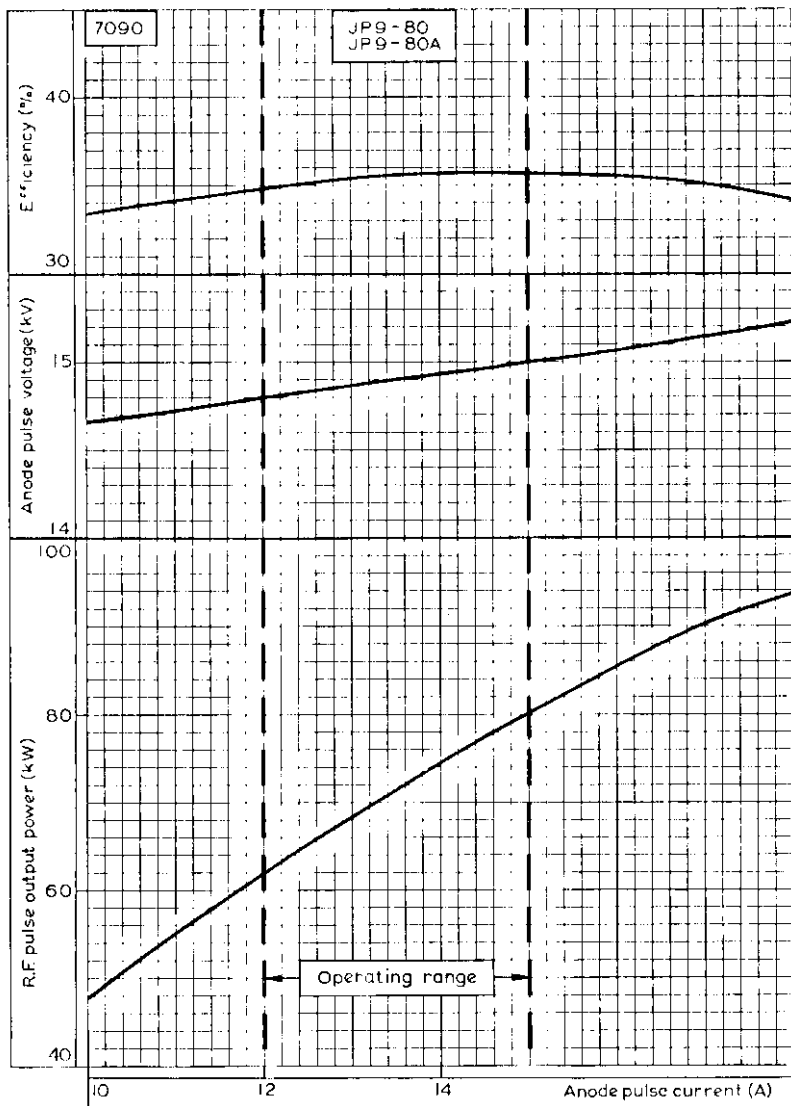

R.F. PULSE OUTPUT POWER, ANODE PULSE VOLTAGE AND EFFICIENCY
PLOTTED AGAINST ANODE PULSE CURRENT

JP9-80 JP9-80A

MAGNETRON

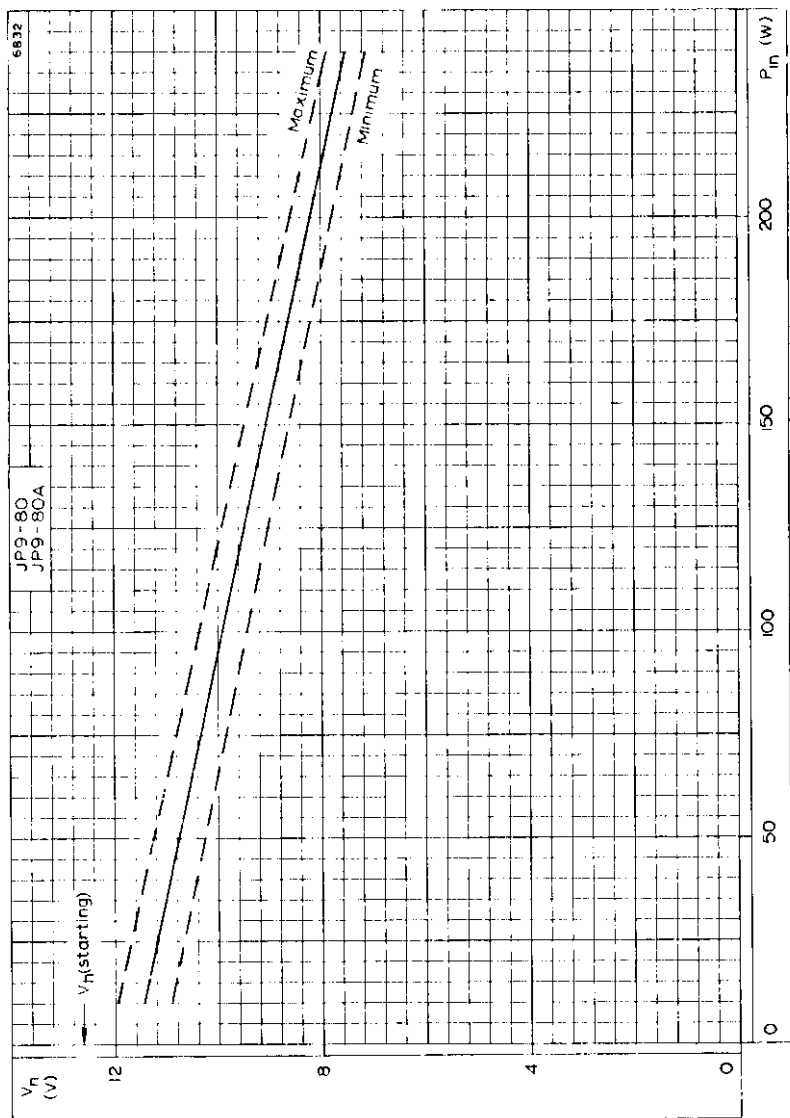

REDUCTION OF HEATER VOLTAGE PLOTTED AGAINST INPUT POWER

MAGNETRON

Frequency: 'X' band.
 Output power: 190kW, pulsed.
 Construction: Packaged, forced-air cooled.

JP9-180

PRELIMINARY DATA

This data should be read in conjunction with GENERAL OPERATIONAL RECOMMENDATIONS - MICROWAVE DEVICES which precede this section of the handbook.

CHARACTERISTICS

	Min.	Max.	
Frequency			
Fixed within the band	9.325 to	9.425	Gc/s
Pulse voltage ($I_{p(max)} = 22.5A$)	18	23	kV
R.F. pulse output power ($I_{p(max)} = 22.5A$)	150	—	kW
Frequency pulling factor (v.s.w.r. = 1.5)	—	15	Mc/s
Frequency temperature coefficient	—	-250	xc/s per °C

CATHODE

Indirectly heated

V_h	12.6	V
I_h	2.25	A
$I_{h(max)}$	7.5	A
r_{heated}	0.67	Ω

Heating time. At ambient temperatures above 0°C the cathode must be heated for at least 3 minutes before the application of full h.t. Below this temperature the heating time must be increased to at least 4 minutes.

It is necessary to reduce the heater voltage immediately after the application of h.t. in accordance with the input power-heater voltage rating chart on page C2.

TYPICAL OPERATION

Duty cycle	0.0004	
Heater voltage (running)	8.0	V
Pulse duration	1.0	μs
Pulse repetition frequency	400	p/s
Pulse current	22.5	A
Pulse voltage	20.5	kV
Pulse input power	460	kW
R.F. pulse output power	180	kW
Mean input current	9.0	mA
Mean input power	184	W
Mean r.f. output power	72	W
Frequency pulling (v.s.w.r. = 1.5)	13	Mc/s
Rate of rise of pulse voltage	100	kV/ μs

COOLING

It is necessary to direct a flow of cooling air between the radiator fins, and on the cathode and heater seals, in order to keep the temperature below the permitted maximum.

LIMITING VALUES (absolute ratings)

	Min.	Max.	
Pulse current	16	25	A
Pulse voltage	7	24	kV
Pulse duration	—	2.0	μs
Duty cycle	—	0.0005	
Mean input power	—	250	W
Rate of rise of voltage pulse	—	110	kV/μs
Load mismatch (v.s.w.r.)	—	1.5	
Temperature of anode block	—	140	°C
Temperature of cathode and heater seals	—	200	°C

MOUNTING POSITION

Any

PRESSURISING

The valve can be operated in the pressure range 600 to 2370mm of mercury.

DIMENSIONS

	Inches	Millimetres		Inches	Millimetres
A	3.500	88.9		J	0.4985 ± 0.0005
B	2.500 ± 0.010	63.5 ± 0.25		V	1.352 ± 0.004
C	0.625 ± 0.015	15.9 ± 0.4		W	0.676
D	3.000 ± 0.010	76.2 ± 0.25		X	0.125
E	1.500	38.1		Y	1.375
F	1.750	44.5		Z	1.200
G	0.907 ± 0.025	23.0 ± 0.6		AA	1.500
H	1.437	36.5		BB	0.625
J	0.125	3.18		CC	1.792 ± 0.020
K	2.875	73.0	max.	DD	0.156 ± 0.031
L	2.187 ± 0.015	55.5 ± 0.4		EE	0.169 ± 0.005
M	4.125	104.8		FF	0.250 ± 0.015
N	1.500 ± 0.015	38.1 ± 0.4		GG	0.540 ± 0.005
P	0.125	3.18			-0.008
Q	0.281	7.14		HH	3.545
R	7.687	195.3	max.	JJ	2.548 ± 0.062
S	1.474 ± 0.004	37.5 ± 0.1		KK	1.122 ± 0.003
T	0.737	18.7			

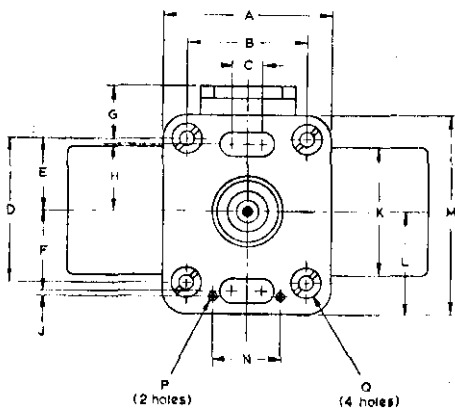

Cathode terminal assembly

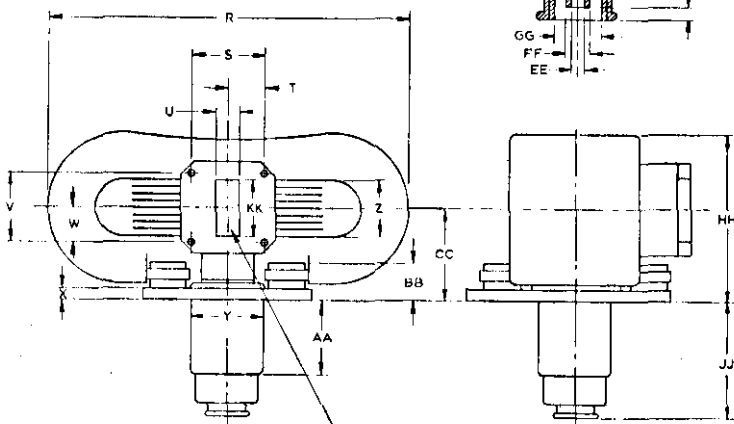
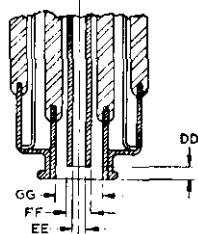

Outlet via waveguide WG15 to take bolted flange choke coupling inter-services type 2630033

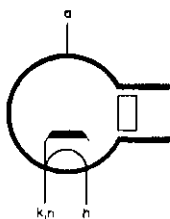

7268

The anode is terminated at the base plate.

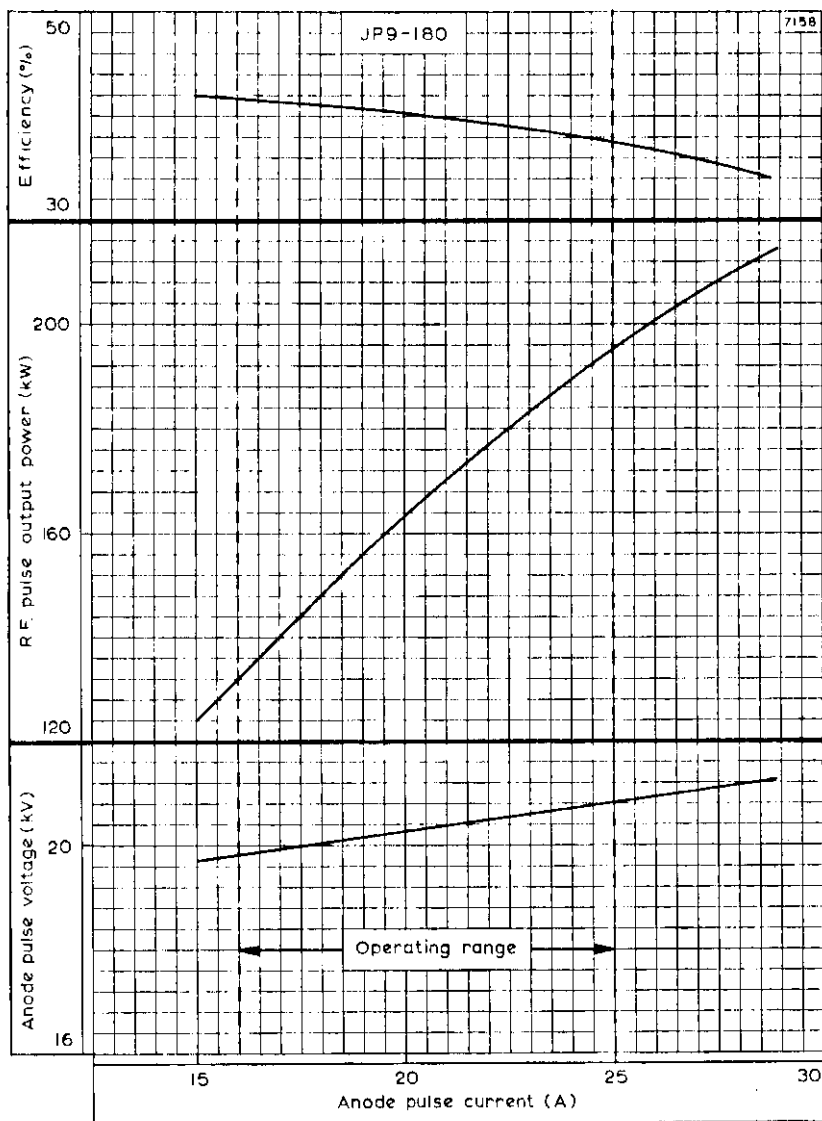

ANODE PULSE VOLTAGE, R.F. PULSE OUTPUT POWER AND EFFICIENCY
PLOTTED AGAINST ANODE PULSE CURRENT

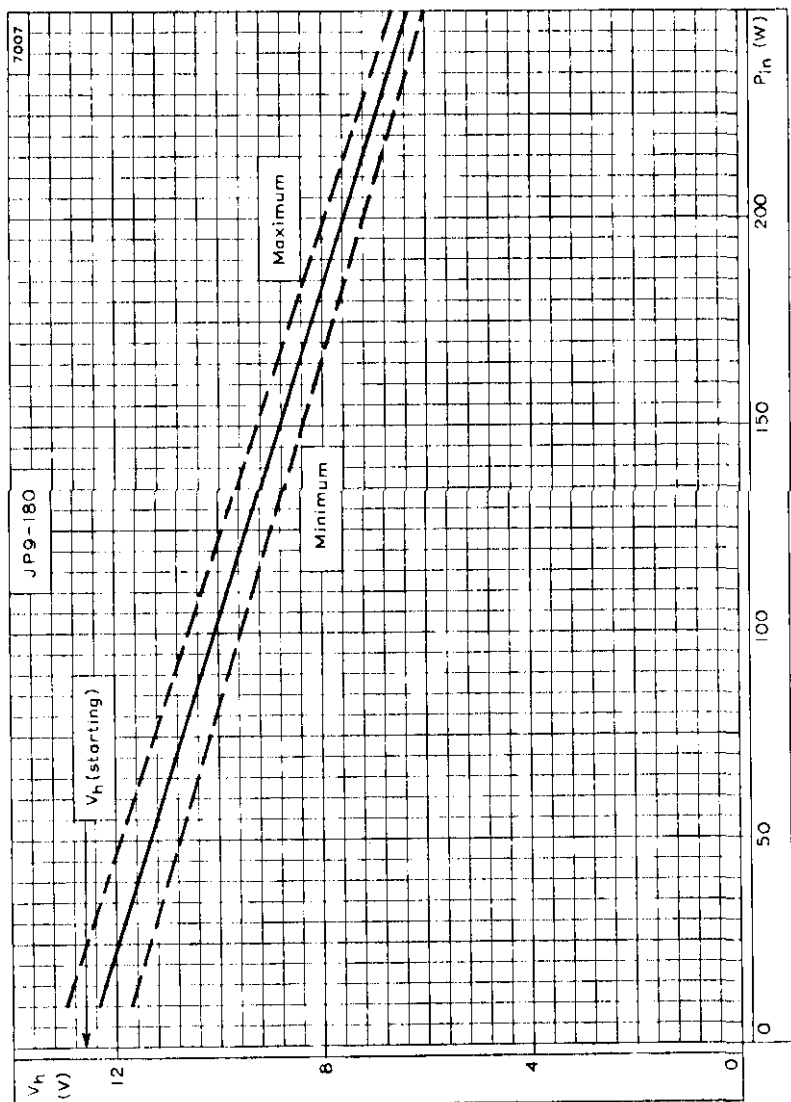

REDUCTION OF HEATER VOLTAGE PLOTTED AGAINST MEAN INPUT POWER

MAGNETRON

Frequency: 'X' band.
 Power output: 250kW pulsed.
 Construction: Packaged, forced-air cooled.

JP9-250 Series

This data should be read in conjunction with GENERAL OPERATIONAL RECOMMENDATIONS - MICROWAVE DEVICES which precede this section of the handbook.

CHARACTERISTICS

Frequency:	Min.	Max.	
Fixed within band			
JP9-250	9.345 to 9.405		Gc/s
JP9-250A	9.003 to 9.168		Gc/s
JP9-250B	8.830 to 8.995		Gc/s
JP9-250C	8.865 to 8.995		Gc/s
JP9-250D	8.665 to 8.830		Gc/s
JP9-250E	8.500 to 8.665		Gc/s
Pulse voltage ($I_{pulse} = 27.5A$)	20	23	kV
R.F. pulse power output ($I_{pulse} = 27.5A$)	225	—	kW
Frequency pulling factor (v.s.w.r. = 1.5)	—	15	Mc/s
Frequency temperature coefficient	—	-250	kc/s per °C
Position of phase of sink from face of mounting plate towards load	0.25	to 0.4	λg

CATHODE

Indirectly heated

V_h	13.75	V
I_h	3.25	A
I_h (surge)	15	A
r_h (cold)	0.58	Ω

Heating time. The cathode must be heated for at least 3 minutes before the application of h.t.

It is necessary to reduce the heater voltage immediately after the application of h.t. in accordance with the input power-heater voltage rating chart on page C2.

TYPICAL OPERATION

Duty cycle	0.001	0.001	0.001	
Heater voltage (running)	6.6	7.4	9.3	V
Pulse duration	0.5	2.0	5.0	μs
Pulse repetition frequency	2000	500	200	p/s
Pulse current	27.5	25	18	A
Pulse voltage	21.5	21.3	20.7	kV
Pulse input power	590	532	373	kW
R.F. pulse output power	250	225	155	kW
Mean input current	27.5	25	18	mA
Mean input power	590	532	373	W
Mean r.f. output power	250	225	155	W
Frequency pulling (v.s.w.r. = 1.5)	14	14	14	Mc/s
Rate of rise of pulse voltage	140	110	90	kV/μs

COOLING

It is necessary to direct a flow of cooling air between the radiator fins, and on the cathode and heater seals, in order to keep the temperature below the permitted maximum.

Series

LIMITING VALUES (absolute ratings)

	Min.	Max.	
Pulse current $\leq 1.2\mu\text{s}$	15	27.5	A
$\approx 6.0\mu\text{s}$	15	18	A
Pulse voltage	18.5	23	kV
Pulse duration	—	6.0	μs
Duty cycle	—	0.001	
Mean input power	—	750	W
Rate of rise of voltage pulse	70	160	kV/ μs
Load mismatch (v.s.w.r.)	—	1.5	
Temperature of anode block	—	150	$^{\circ}\text{C}$
Temperature of cathode and heater seals	—	165	$^{\circ}\text{C}$

MOUNTING POSITION

Any

PRESSURISING

The valve can be operated in the pressure range 600 to 2050mm of mercury.

PHYSICAL DATA

Weight of magnetron	{ 10 4.5	lb kg
Weight of magnetron in carton	{ 13 6.0	lb kg
Dimensions of storage carton	{ 7.0 × 9.6 × 11.2 178 × 244 × 284.5	in mm

DIMENSIONS

	Inches	Millimetres		Inches	Millimetres	
A	3.874	98.4	max.	W	1.830 ± 0.01	46.48 ± 0.25
B	3.000 ± 0.01	76.20 ± 0.25		X	1.500	38.1
C	0.906 ± 0.02	23.0 ± 0.5		Y	0.750	19.05
D	0.250	6.35		Z	0.516	13.1
E	3.469	88.1	max.	AA	0.115	3.175
F	2.500 ± 0.01	63.50 ± 0.25		BB	0.250 ± 0.02	6.35 ± 0.40
G	0.512	10.3R		CC	0.169 ± 0.004	4.3 ± 0.1
H	0.281	7.14		DD	0.539 ± 0.004	13.7 ± 0.1
J	2.874	73	max.		-0.008	-0.2
K	1.830	46.48		EE	0.750	19.05
L	1.474 ± 0.004	37.44 ± 0.10		FF	0.830 ± 0.008	21.08 ± 0.20
M	3.603	91.52	max.		-0.004	-0.10
N	2.680 ± 0.06	68.25 ± 1.50		GG	1.252	31.8
P	1.653 ± 0.02	41.99 ± 0.50		HH	0.125 ± 0.01	3.175 ± 0.250
Q	0.625 ± 0.03	15.88 ± 0.80		JJ	0.125	3.175
R	1.122	28.50		KK	0.187	4.75
S	0.497	12.62		LL	0.250	6.35
T	1.250	31.75		MM	7.687	195.25
U	1.000 ± 0.04	25.4 ± 1.0		NN	4.000	101.6
V	1.352 ± 0.004	34.34 ± 0.10			0.500	12.7



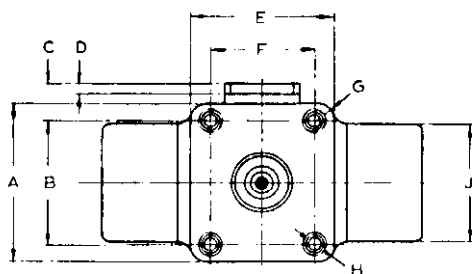

Outlet via waveguide WG15
to take bolted flange choke
coupling inter-services
type ZB30033

4 holes No 8 (O 164th) - 32 UNC 2 B
1/4" min screw penetration

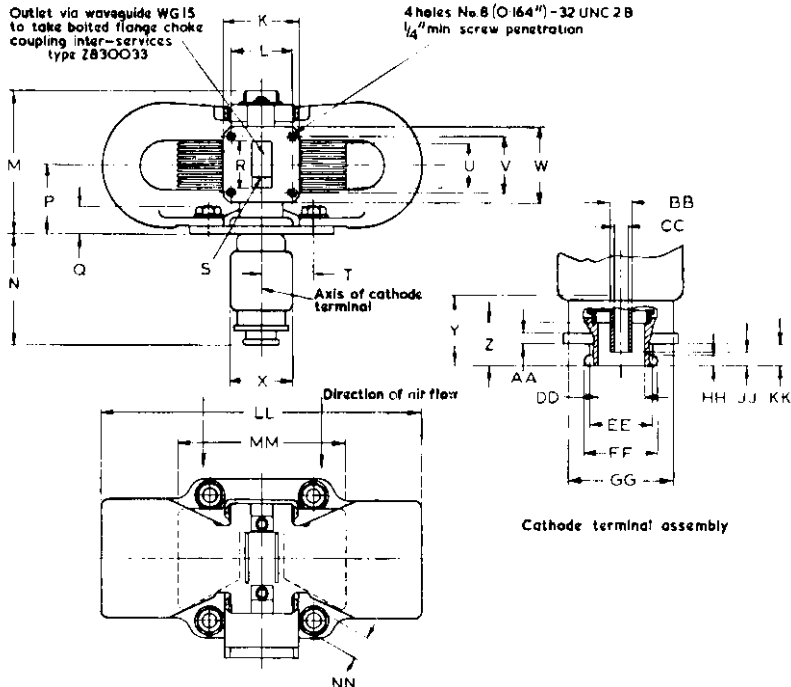

7270

The common heater cathode terminal is the sleeve of the cap, the other heater terminal is the centre contact. The anode connection is terminated at the base plate.

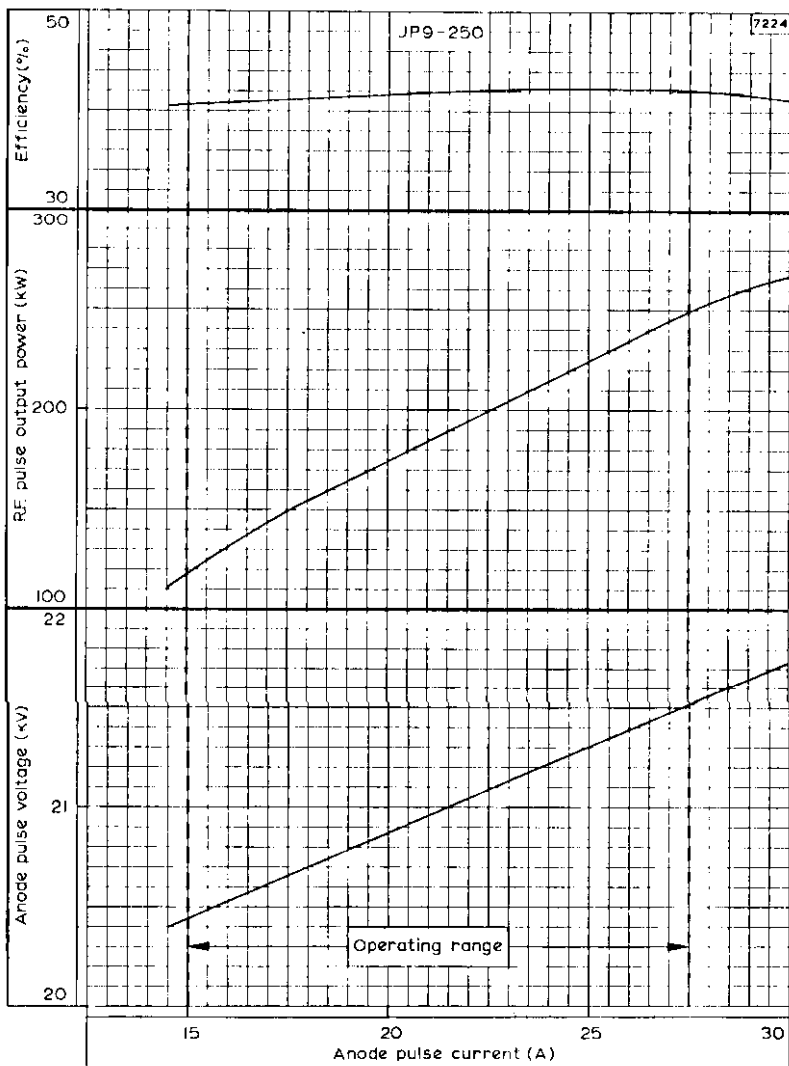

ANODE PULSE VOLTAGE R.F. PULSE OUTPUT POWER AND EFFICIENCY
PLOTTED AGAINST ANODE PULSE CURRENT

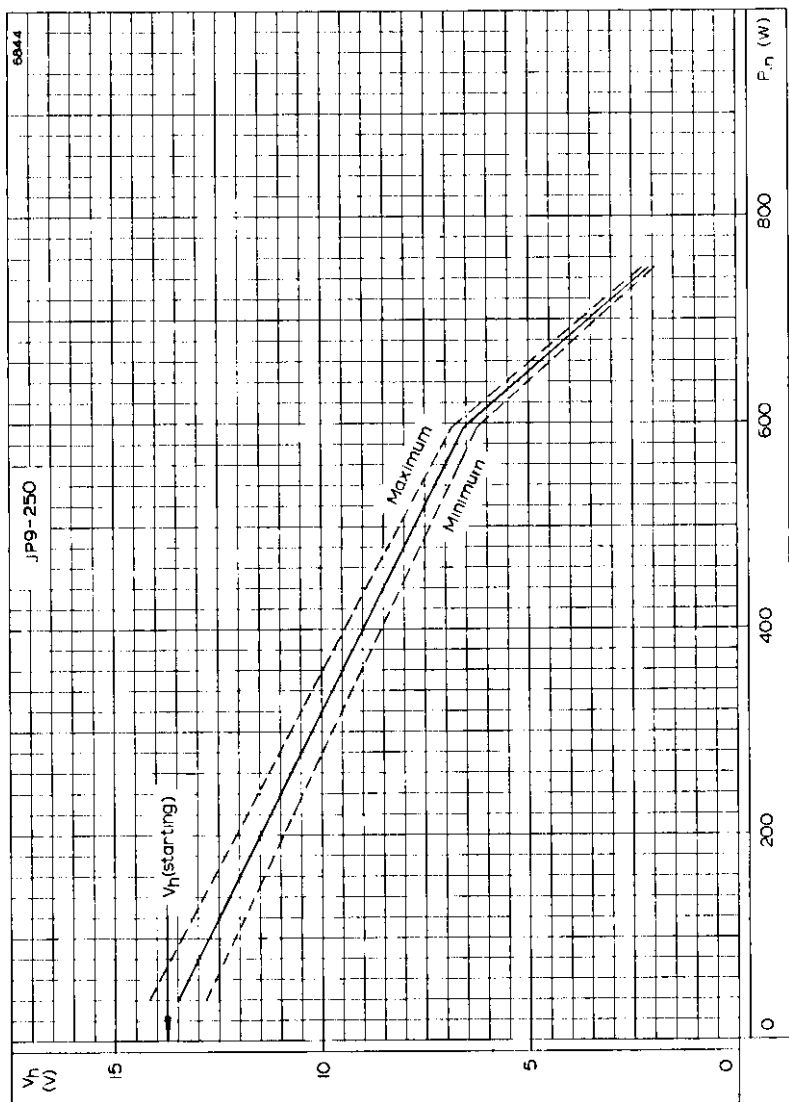

HEATER VOLTAGE PLOTTED AGAINST MEAN INPUT POWER

TUNABLE MAGNETRON

JPG8-01 JPG8-01B JPT8-01 JPT8-01B

Frequency: 'X' band, mechanically tunable.

Power output: 10W, c.w.

Construction: Packaged, forced-air cooled.

The only difference between the JPG8-01 and the JPT8-01 is in the mechanical tuning arrangement (see appropriate outline drawing). The suffix 'B' indicates a frequency variant of the basic type.

PRELIMINARY DATA

This data should be read in conjunction with GENERAL OPERATIONAL RECOMMENDATIONS - MICROWAVE DEVICES which precede this section of the handbook.

CHARACTERISTICS

Frequency	Min	Max.	
Tunable over the range			
JPG8-01 JPT8-01	8.6	to 9.15	Gc/s
JPG8-01B JPT8-01B	8.0	to 8.6	Gc/s
Operating voltage (I = 50mA)	0.9	1.1	kV
R.F. power output (I = 50mA)	5.0	—	W
Frequency pulling factor	—	20	Mc/s
Frequency pushing factor	—	1.0	Mc/s per mA
Frequency temperature coefficient	—	-500	kc/s per °C

CATHODE

Indirectly heated

V_h	6.3	V
I_h	1.1	A

Heating time. At ambient temperatures above 0°C the cathode must be heated for at least 2 minutes before the application of h.t. Below this temperature the heating time must be increased to at least 3 minutes.

For mean input powers greater than 20 watts it is necessary to reduce the heater voltage immediately after the application of h.t. in accordance with the input power-heater voltage rating chart on page C1

TYPICAL OPERATION

	JPG8-01B JPT8-01B	JPG8-01 JPT8-01	
Frequency	8.3	8.9	Gc/s
Heater voltage (running)	4.5	4.5	V
Operating voltage	1.0	1.0	kV
Operating current	50	50	mA
Input power	50	50	mW
R.F. power output	10.6	10.6	W
Frequency pulling (v.s.w.r. = 1.5)	15	15	Mc/s

OPERATING NOTE

The impedance of the a.t. supply should be greater than 5k Ω . In addition a limiting resistor of 1k Ω should be inserted in series with the magnetron.

COOLING

It is necessary to direct a flow of cooling air between the radiator fins in order to keep the temperature below the permitted maximum.

LIMITING VALUES (absolute ratings)

	<i>Min.</i>	<i>Max.</i>	
Operating current (unmodulated c.w.)	20	60	mA
Peak operating current (modulated c.w.)	—	100	mA
Operating voltage	0.85	1.15	kV
Mean input power	—	60	W
Load mismatch (v.s.w.r.)	—	1.5	
Temperature of anode block	—	140	$^{\circ}$ C

MOUNTING POSITION

Any

PHYSICAL DATA

Weight of magnetron	{	1 lb	8 oz
		680	g
Weight of magnetron in carton	{	2 lb	8 oz
		1.13	kg
Dimensions of storage carton	{	5.0 x 7.0 x 7.5	in
		127 x 178 x 190	mm



DIMENSIONS AND OUTLINE DRAWING OF JPG8-01 AND JPG8-01B

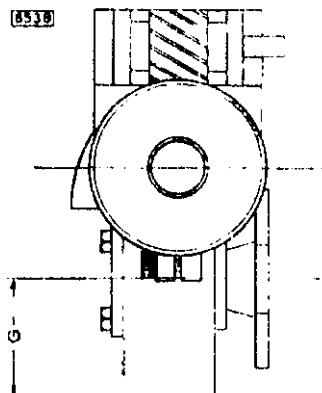

	<i>Inches</i>	<i>Millimetres</i>	
A	2.56	65	max.
B	1.26 ± 0.08	32 ± 2	
C	1.97	50	max.
D	5.32	135	max.
E	0.984 ± 0.04	25 ± 1	
F	2.24	57	max.
G	1.26	32	max.
H	1.73 ± 0.03	44 ± 2	
J	1.24	31.4	
K	5	127	
L	0.512	13	max.

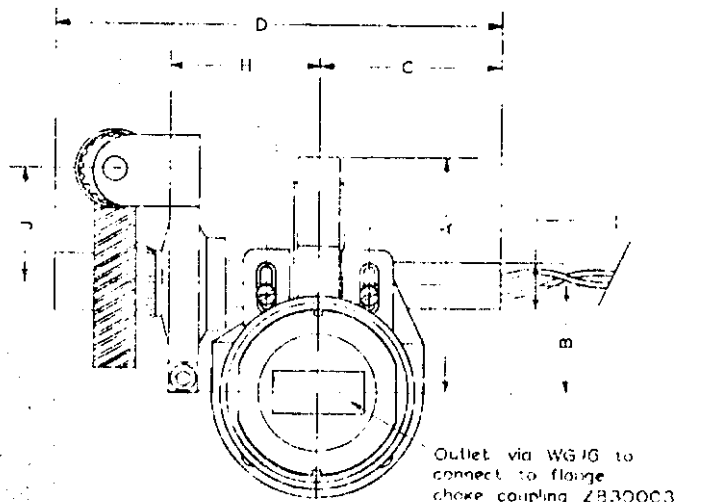

Red lead - heater terminal
 Blue lead - common heater
 cathode terminal

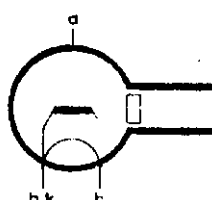
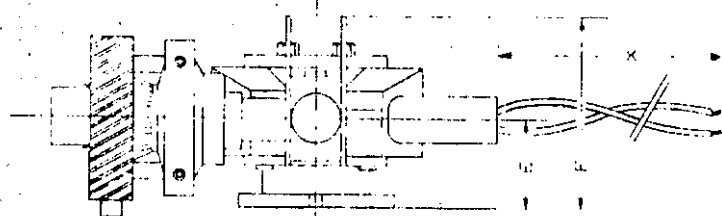

6537

ANODE CONNECTION TERMINATED AT THE BASE PLATE

DIMENSIONS AND OUTLINE DRAWING OF JPT8 01 AND JPT8-01B

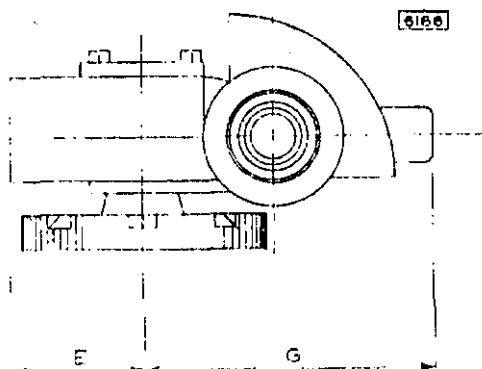

	<i>Inches</i>	<i>Millimetres</i>	
A	3.34	85	max.
B	1.97	50	max.
C	0.51*	13	max.
D	1.26 ± 0.12	32 ± 3	
E	1.26	32	max.
G	2.56	65	max.
H	0.6 ± 0.007	15.5 ± 0.2	
J	0.86 ± 0.007	22 ± 0.2	
K	1.24 ± 0.007	31.5 ± 0.2	
L	1.063	27	max.
M	2.24	57	max.
N	5	127	

JPG8-01 JPG8-01B
JPT8-01 JPT8-01B

TUNABLE MAGNETRON

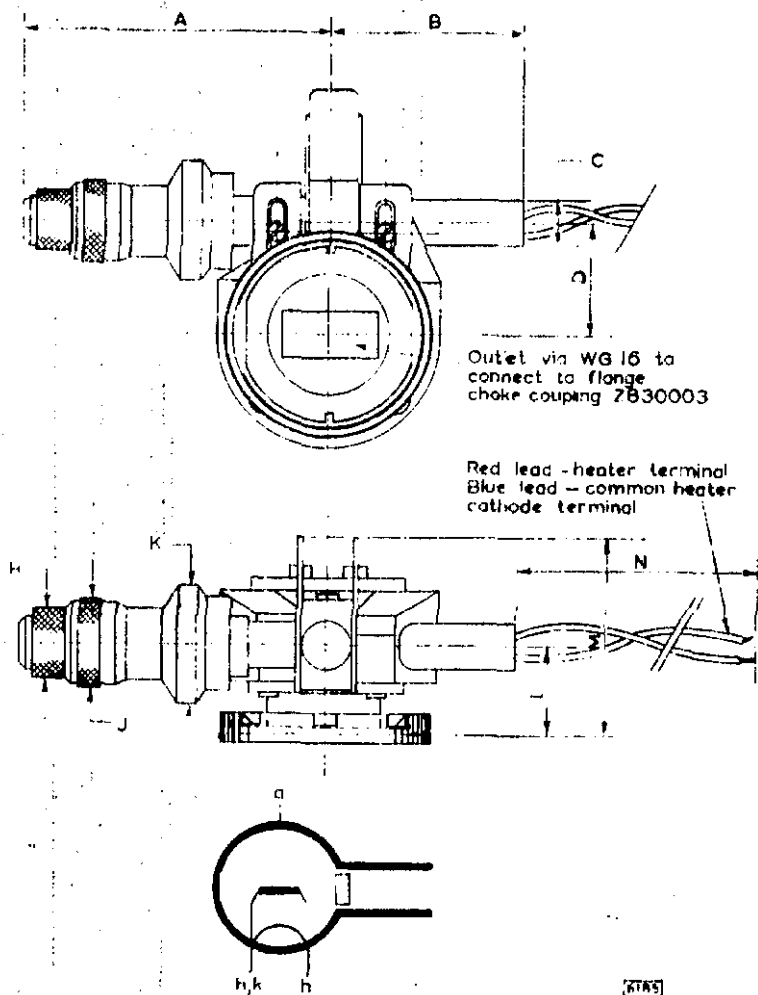

ANODE CONNECTION TERMINATED AT THE BASE PLATE

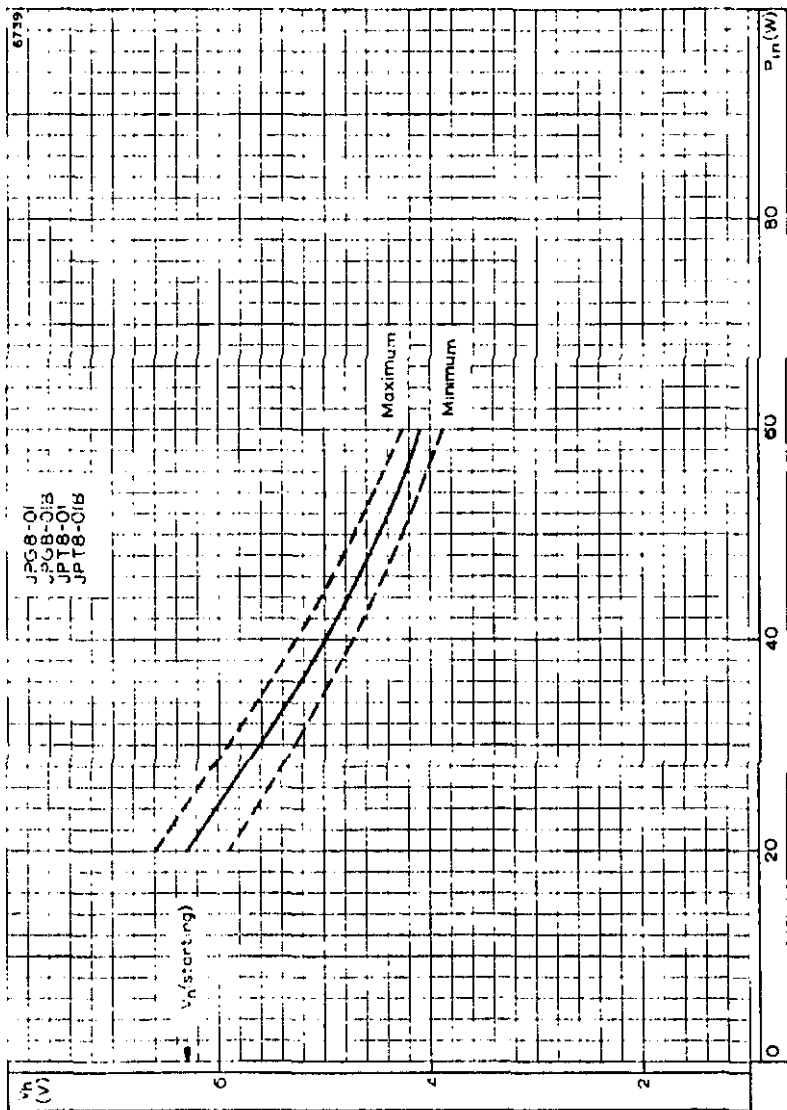

HEATER VOLTAGE PLOTTED AGAINST INPUT POWER

TUNABLE MAGNETRON

JPG9-01 JPT9-01

Frequency: 'X' band, mechanically tunable.

Power output: 10W, c.w.

Construction: Packaged, forced-air cooled.

The only difference between the JPG9-01 and the JPT9-01 is in the mechanical tuning arrangement (see appropriate outline drawing)

This data should be read in conjunction with GENERAL OPERATIONAL RECOMMENDATIONS—MICROWAVE DEVICES which precede this section of the handbook.

CHARACTERISTICS

Frequency	Min.	Max.	
Tunable over the range	9.15	to 9.6	Gc/s
Operating voltage ($I = 50\text{mA}$)	0.9	to 1.1	kV
R.F. power output ($I = 50\text{mA}$)	5.0	—	W
Frequency pulling factor (v.s.w.r. = 1.5)	—	20	Mc/s
Frequency pushing factor	—	1.0	Mc/s per mA
Frequency temperature coefficient	—	-500	kc/s per °C

CATHODE

Indirectly heated

V_{h1}	6.3	V
I_{h1}	1.1	A

Heating time. At ambient temperatures above 0°C the cathode must be heated for at least 2 minutes before the application of h.t. Below this temperature the heating time must be increased to at least 3 minutes. For mean input powers greater than 20 watts it is necessary to reduce the heater voltage immediately after the application of h.t. in accordance with the input power-heater voltage rating chart on page C3.

TYPICAL OPERATION

Frequency	9.2	9.4	9.55	Gc/s
Heater voltage (running)	4.5	4.5	4.5	V
Operating voltage	920	930	930	V
Operating current	50	50	50	mA
Input power	46	46	46	W
R.F. power output	10.5	10.5	9.8	W
Frequency pulling (v.s.w.r. = 1.5)	19	16	14	Mc/s

OPERATING NOTE

The impedance of the h.t. supply should be greater than 5k Ω . In addition a limiting resistor of 1k Ω should be inserted in series with the magnetron.

COOLING

It is necessary to direct a flow of cooling air of at least 5 cu. ft. per minute between the radiator fins in order to keep the temperature below the permitted maximum.

JPG9-01

JPT9-01

TUNABLE MAGNETRON

LIMITING VALUES (absolute ratings)

	Min.	Max.	
Operating current (unmodulated c.w.)	20	60	mA
Peak operating current (modulated c.w.)	—	100	mA
Operating voltage (modulated c.w.)	0.85	1.15	kV
Mean input power	—	60	W
Load mismatch (v.s.w.r.)	—	1.5	
Temperature of anode block	—	140	°C

PHYSICAL DATA

Weight of magnetron	{ 1 lb 8 oz 710	g
Weight of magnetron in carton	{ 2 lb 8 oz 1.16	kg
Dimensions of storage carton	{ 5.0 · 7.0 · 7.5 127 · 178 · 190	in. mm

DIMENSIONS AND OUTLINE DRAWING OF JPT9-01

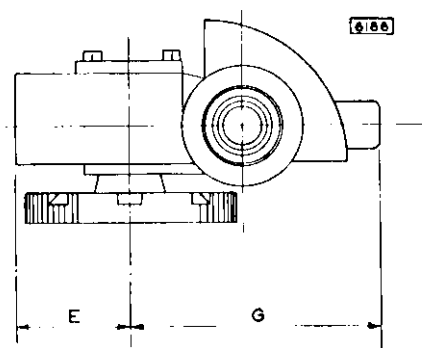

	Inches	Millimetres	
A	3.34	85	max.
B	1.97	50	max.
C	0.511	13	max.
D	1.26 0.12	32 3	
E	1.26	32	max.
G	2.56	65	max.
H	0.6 0.007	15.5 0.2	
J	0.86 0.007	22 0.2	
K	1.24 0.007	31.5 0.2	
L	1.063	27	max.
M	2.24	57	max.
N	5	127	



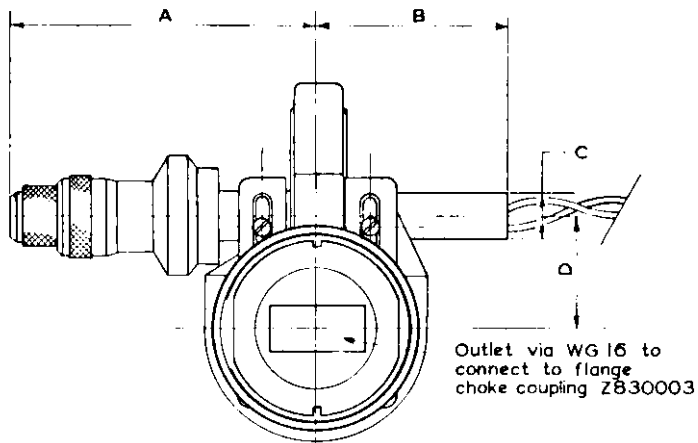

Red lead—heater terminal
Blue lead—common heater cathode terminal

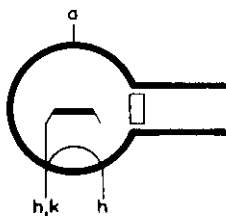
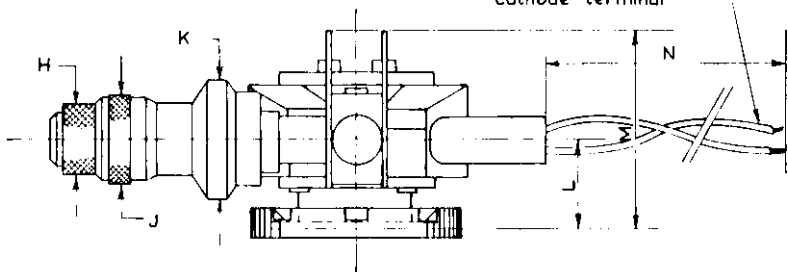

1185

ANODE CONNECTION TERMINATED AT THE BASE PLATE

DIMENSIONS AND OUTLINE DRAWING OF JPG9-01

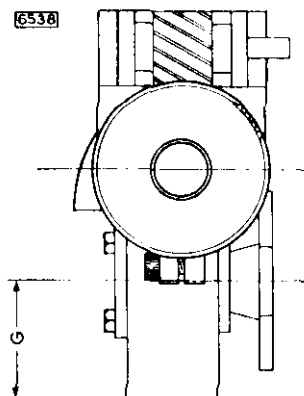

	<i>Inches</i>	<i>Millimetres</i>	
A	2.56	65	max.
B	1.26 ± 0.08	32 ± 2	
C	1.97	50	max.
D	5.32	135	max.
E	0.984 ± 0.04	25 ± 1	
F	2.24	57	max.
G	1.26	32	max.
H	1.73 ± 0.08	44 ± 2	
J	1.24	31.4	
K	5	127	
L	0.512	13	max.

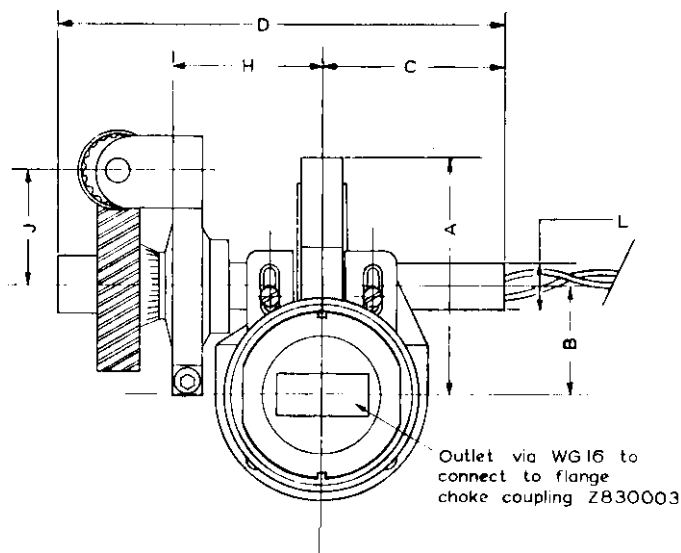

Red lead - heater terminal
Blue lead - common heater cathode terminal

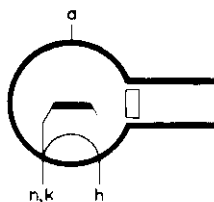
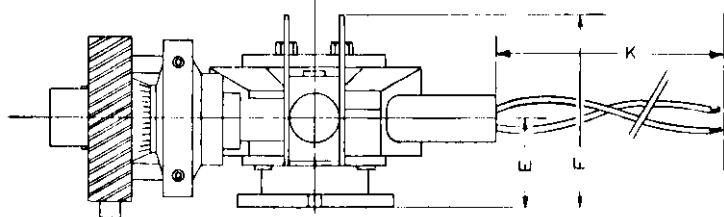

6539

ANODE CONNECTION TERMINATED AT THE BASE PLATE

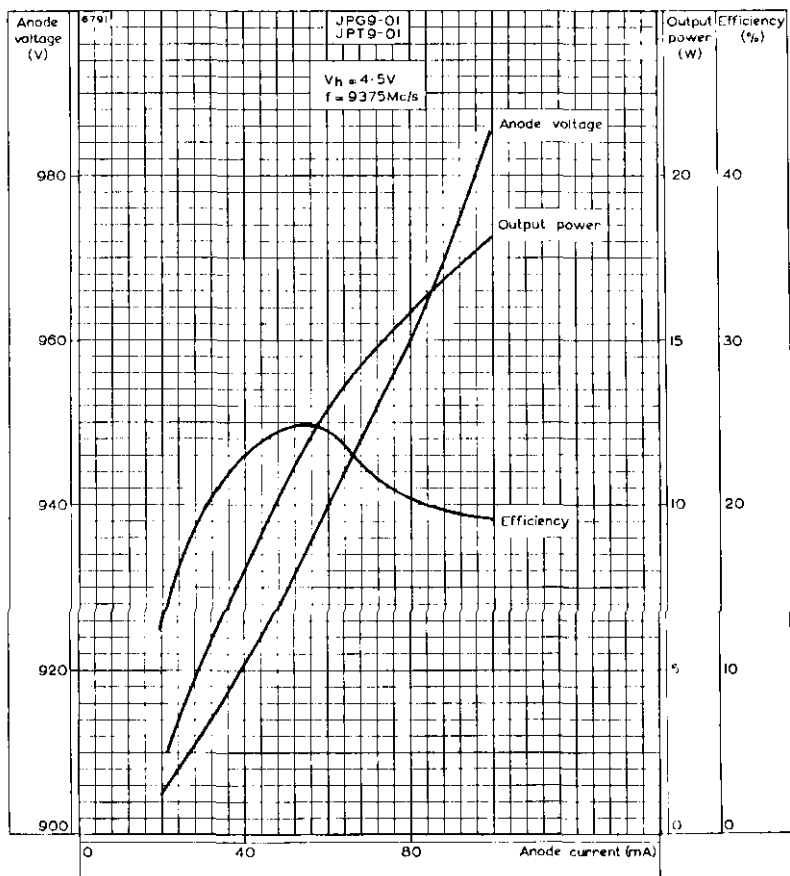

ANODE VOLTAGE, OUTPUT POWER AND EFFICIENCY PLOTTED AGAINST ANODE CURRENT

JPG9-01 JPT9-01

TUNABLE MAGNETRON

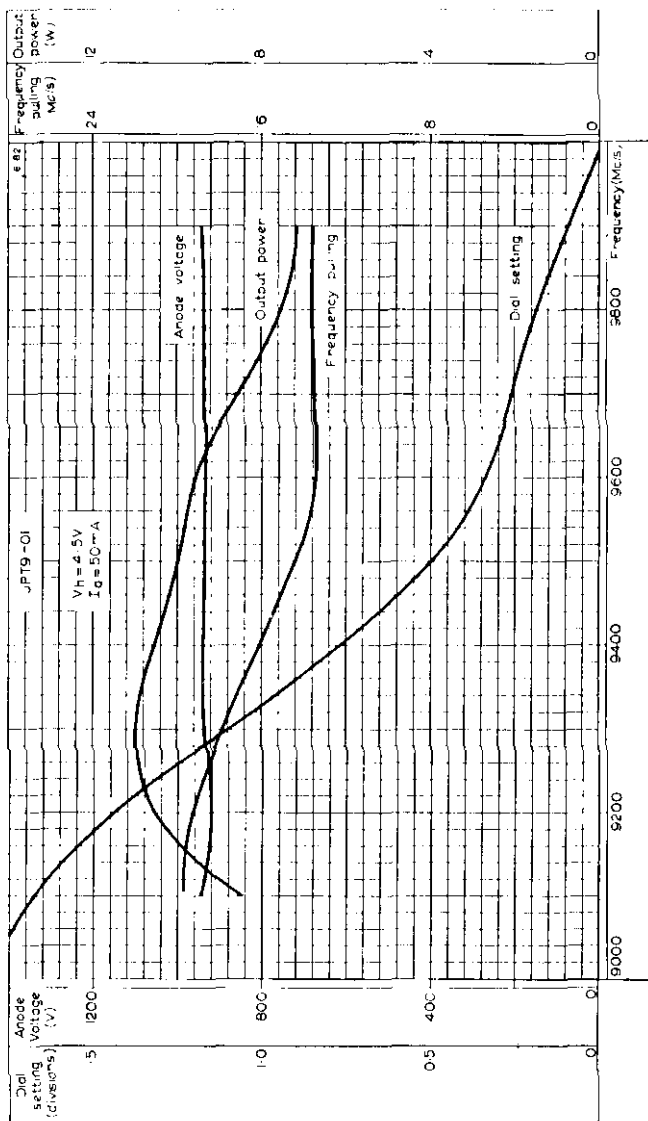

ANODE VOLTAGE, OUTPUT POWER AND FREQUENCY PULLING FOR JPG9-01 AND JPT9-01 TOGETHER WITH DIAL SETTING FOR JPT9-01 PLOTTED AGAINST FREQUENCY

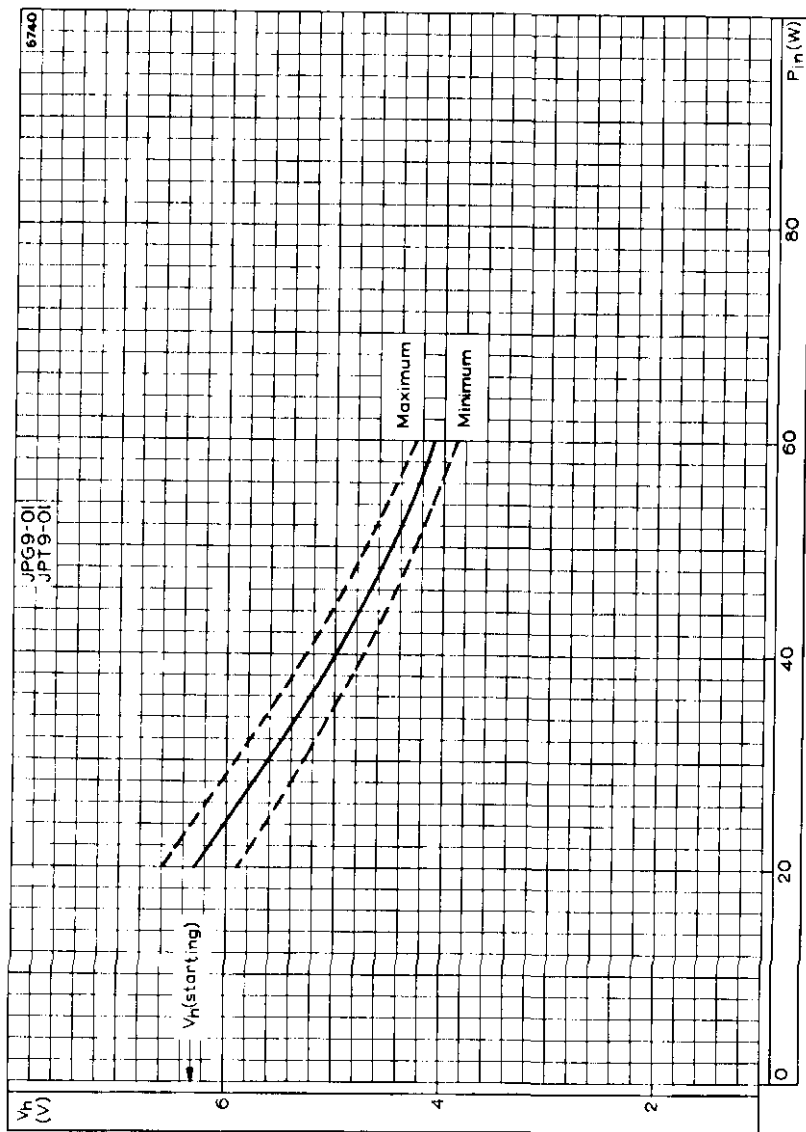

HEATER VOLTAGE PLOTTED AGAINST INPUT POWER

TUNABLE MAGNETRON

Frequency: 'X' Band, mechanically tunable.

Power output: 25W, pulsed.

Construction: Packaged.

JPG9-02

JPT9-02

The only difference between the JPG9-02 and the JPT9-02 is in the mechanical tuning arrangement (see appropriate outline drawing)

This data should be read in conjunction with GENERAL OPERATIONAL RECOMMENDATIONS—MICROWAVE DEVICES which precede this section of the handbook.

CHARACTERISTICS

	Min.	Max.	
Frequency			
Tunable over the range	9.15	to 9.6	Gc/s
Pulse voltage ($I_{pulse} = 120mA$)	0.95	1.15	kV
R.F. pulse output ($I_{pulse} = 120mA$)	18	—	W
Frequency pulling factor (v.s.w.r. = 1.5)	—	20	Mc/s
Frequency pushing factor	—	1.0	Mc/s per mA
Frequency temperature coefficient	—	-500	kc/s per °C
Input capacitance	—	12	pF

CATHODE

Indirectly heated

V_h	6.3	V
I_h	1.1	A

Heating time At ambient temperatures above 0°C the cathode must be heated for at least 2 minutes before the application of h.t. Below this temperature the heating time must be increased to at least 3 minutes.

TYPICAL OPERATION

Frequency	9.2	9.4	9.55	Gc/s
Heater voltage (running)	6.3	6.3	6.3	V
Pulse duration	0.5	0.5	0.5	μs
Pulse repetition frequency	1000	1000	1000	p/s
Duty cycle	0.0005	0.0005	0.0005	
Pulse current	120	120	120	mA
Pulse voltage	1.0	1.0	1.0	kV
Pulse input power	120	120	120	W
R.F. pulse output power	22	25	24	W
Mean input current	60	60	60	μA
Mean input power	60	60	60	mW
Mean r.f. output power	11	12.5	12	mW
Frequency pulling (v.s.w.r. 1.5)	19	16	14	Mc/s
Rate of rise of pulse voltage	10	10	10	kV/μs



JPG9-02 JPT9-02

TUNABLE MAGNETRON

LIMITING VALUES (absolute ratings)

	Min.	Max.	
Pulse current	50	120	mA
Pulse voltage	0.9	1.15	kV
Pulse duration	—	5.0	μs
Duty cycle	—	0.05	
Mean input power	—	6.0	W
Rate of rise of voltage pulse	—	12	kV/μs
Load mismatch (v.s.w.r.)	—	1.5	
Temperature of anode block	—	140	°C

PHYSICAL DATA

Weight of magnetron	{ 1 lb 8 oz 700	g
Weight of magnetron in carton	{ 2 lb 8 oz 1.15	kg
Dimensions of storage carton	{ 5.0 × 7.0 × 7.5 127 · 178 · 190	in. mm

DIMENSIONS AND OUTLINE DRAWING OF JPT9-02

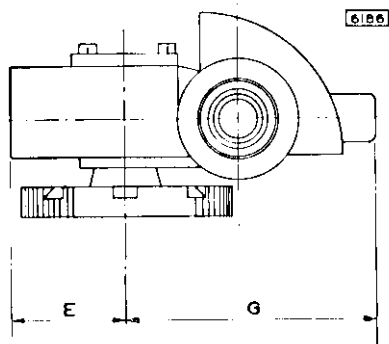

	Inches	Millimetres	
A	3.34	85	max.
B	1.97	50	max.
C	0.511	13	max.
D	1.26 ± 0.12	32 ± 3	
E	1.26	32	max.
G	2.56	65	max.
H	0.6 ± 0.007	15.5 ± 0.2	
J	0.86 ± 0.007	22 ± 0.2	
K	1.24 ± 0.007	31.5 ± 0.2	
L	1.063	27	max.
M	2.24	57	max.
N	5	127	

Mullard

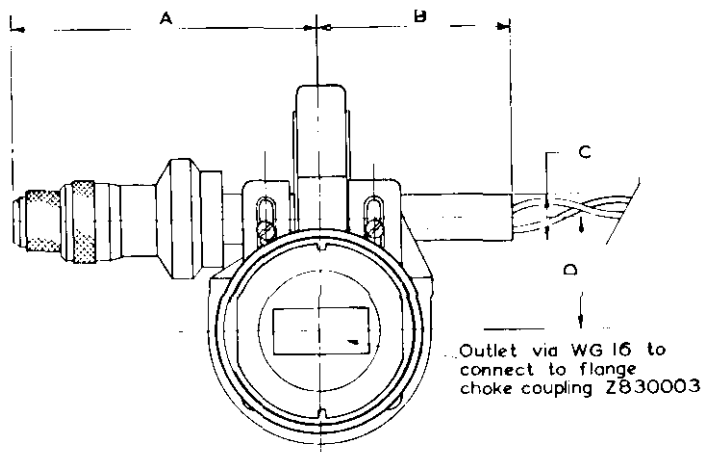

Red lead - heater terminal
Blue lead - common heater
cathode terminal

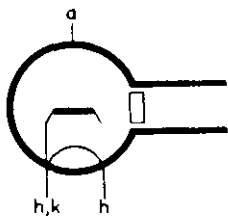
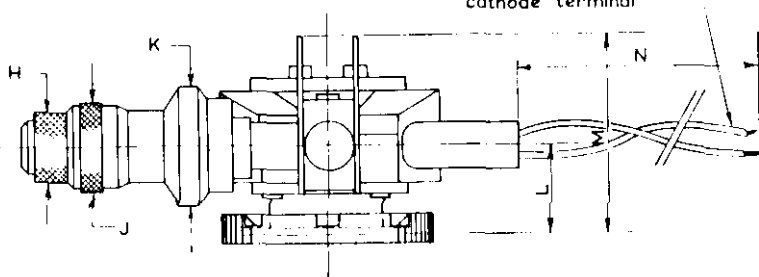

6185

ANODE CONNECTION TERMINATED AT THE BASE PLATE

DIMENSIONS AND OUTLINE DRAWING OF JPG9-02

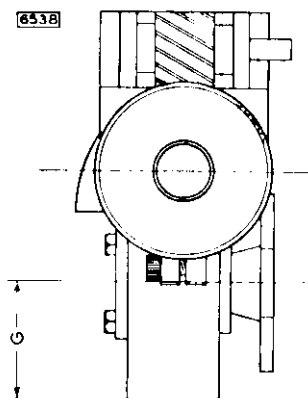

	<i>Inches</i>	<i>Millimetres</i>	
A	2.56	65	max.
B	1.26 ± 0.08	32 ± 2	
C	1.97	50	max.
D	5.32	135	max.
E	0.984 ± 0.040	25 ± 1	
F	2.24	57	max.
G	1.26	32	max.
H	1.73 ± 0.08	44 ± 2	
J	1.24	31.4	
K	5	127	
L	0.512	13	max.

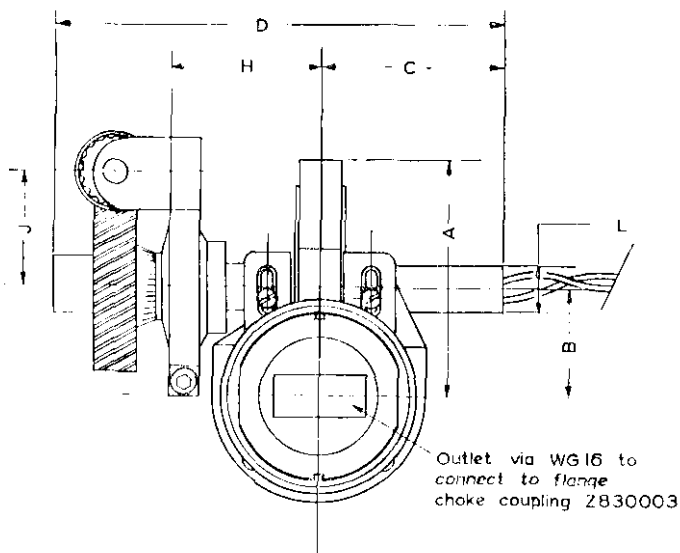

Red lead - heater terminal
Blue lead - common heater
cathode terminal

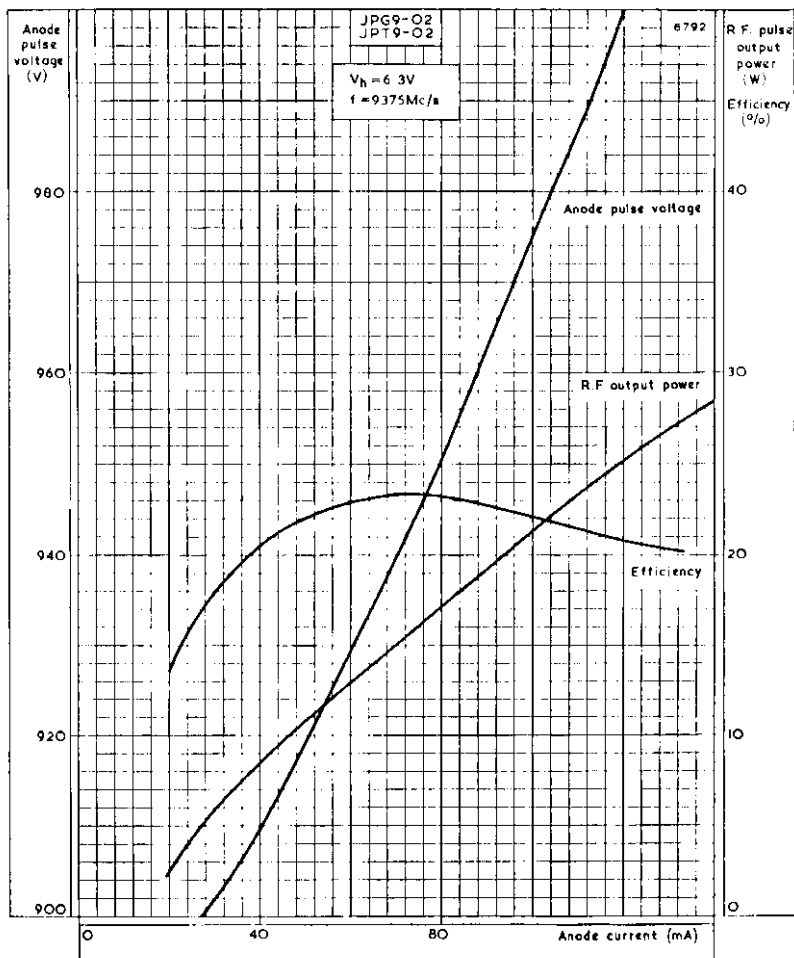

ANODE PULSE VOLTAGE, R.F. PULSE OUTPUT POWER AND EFFICIENCY
PLOTTED AGAINST ANODE CURRENT



JPG9-02 JPT9-02

TUNABLE MAGNETRON

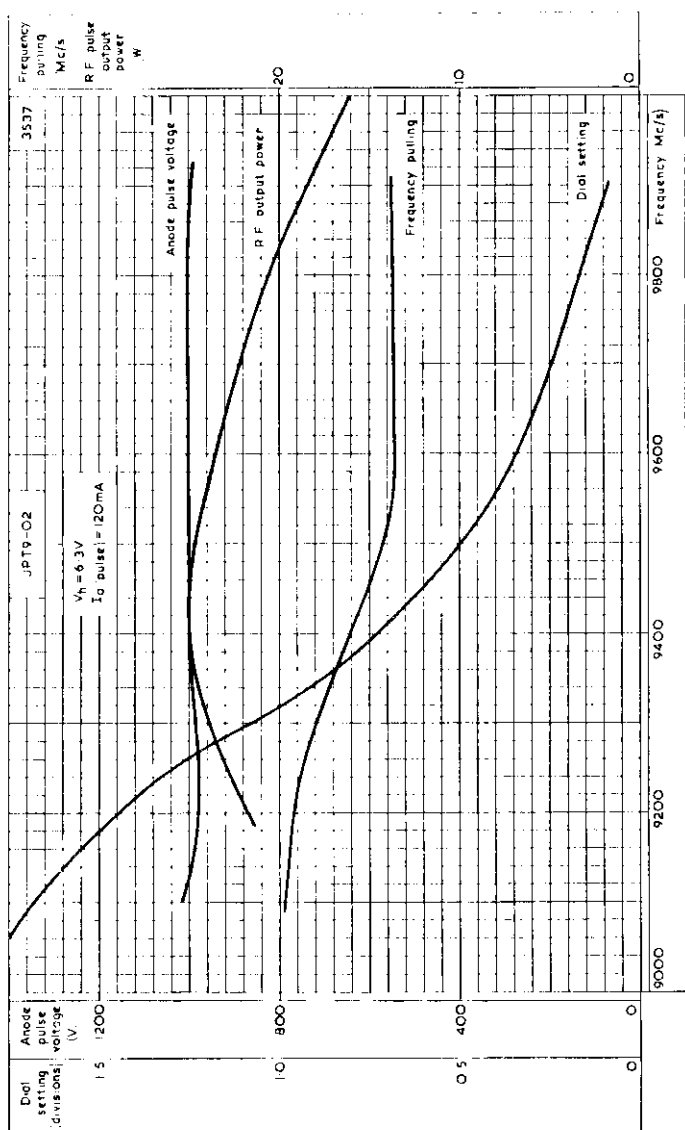

ANODE PULSE VOLTAGE, R.F. PULSE OUTPUT POWER AND FREQUENCY PULLING FOR JPG9-02 AND JPT9-02 TOGETHER WITH DIAL SETTING FOR JPT9-02 PLOTTED AGAINST FREQUENCY



Air-cooled magnetron designed for very short pulse operation

Frequency	34.86	Gc/s
Power output (pulsed)	40	kW
Construction		Packaged

This data should be read in conjunction with GENERAL OPERATIONAL RECOMMENDATIONS—MICROWAVE DEVICES; INTRODUCTION and RADAR AND COMMUNICATIONS MAGNETRONS which precede this section of the handbook.

TYPICAL OPERATION

Heater voltage (running)	4.0	4.0	5.0	V
Pulse duration	0.3	0.1	0.02	μ s
Pulse repetition frequency	670	2000	5000	p/s
Duty cycle	0.0002	0.0002	0.0001	
Pulse current	12.5	12.5	7.5	A
Pulse voltage	11.7	11.7	11.1	kV
Pulse input power	146	146	83	kW
R.F. pulse output power	40	40	30	kW
*Mean input current	2.5	2.5	1.55	mA
Mean input power	35	35	20	W
Mean r.f. output power	8.0	8.0	3.0	W
Frequency pulling factor (v.s.w.r. = 1.5)	35	35	35	Mc/s
Rate of rise of pulse voltage	250	250	600	kV/ μ s

*Includes pre-oscillation current

CATHODE

Indirectly heated, dispenser type

V_h	5.0	V
I_h (at 5.0V)	3.9	A
I_h (surge) max.	8.0	A
r_h (cold)	0.16	Ω

Heating time. At ambient temperatures above 0°C the cathode must be heated for at least 3 minutes before the application of h.t.

For mean input powers greater than 20 watts, it is necessary to reduce the heater voltage immediately after the application of h.t.

In many applications involving short pulse lengths and high pulse repetition frequencies the mean current which would be calculated from the duty cycle is increased by the pre-oscillation current.

In determining the heater reduction it is necessary to obtain the mean input power from the measured mean input current $\times 12,500$. The correct value of nominal heater voltage is given by the curve on page C2.

CHARACTERISTICS

	Min.	Max.	
Frequency			
Fixed within the band	34.51	35.21	Gc/s
Pulse voltage (1 pulse = 12.5A)	11.5	13.5	kV
R.F. pulse output power (1 pulse = 12.5A)	30	—	kW
Frequency pulling factor (v.s.w.r. = 1.5)	—	50	Mc/s
Frequency pushing factor	—	4.0	Mc/s per A
Frequency temperature coefficient	—	-1.0	Mc/s per °C
Position of phase of sink from face of mounting plate out of valve	0.25	0.4	μ g
Input capacitance		6.0	pF

COOLING

For normal operating conditions, a low velocity air-flow is sufficient to keep within the maximum temperature limits.

MOUNTING POSITION

Any

PHYSICAL DATA

Weight of magnetron	}	4lb	3oz
		1.9	kg
Weight of magnetron in carton	}	12lb	13oz
		5.8	kg
Dimensions of storage carton	}	7.0 \times 9.6 \times 11.2	in
		178 \times 244 \times 284.5	mm

DIMENSIONS

	<i>Inches</i>	<i>Millimetres</i>	
A	3.437	87.3	max.
B	2.531 ± 0.010	64.29 ± 0.25	
C	3.622	92	max.
D	1.937	49.2	max.
E	2.781 ± 0.010	70.64 ± 0.25	
F	0.217 ± 0.039	5.5 ± 1.0	
G	0.189	4.8	max.
H	1.874	47.6	min.
J	5.933	150.7	max.
K	3.819	97	min.
L	2.087	53	max.
M	0.906	23	max.
N	0.512	13	max.
P	3.189	81	max.
Q	2.842	72.2	max.
R	1.402 ± 0.039	35.6 ± 1.0	
S	1.968	50	max.
T	0.650 ± 0.059	16.5 ± 1.5	
U	0.433	11	max.
V	0.906	23	max.
AA	0.169 ± 0.006	4.30 ± 0.15	
BB	0.236 ± 0.004	6.0 ± 0.1	
CC	0.524 ± 0.008	13.3 ± 0.2	
DD	0.665 ± 0.008	16.9 ± 0.2	
EE	0.807	20.5	max.
FF	0.022 ± 0.018	0.55 ± 0.45	
GG	0.492	12.5	min.
HH	0.591	15	min.
JJ	0.079	2.0	min.
KK	0.591 ± 0.008	15.0 ± 0.2	

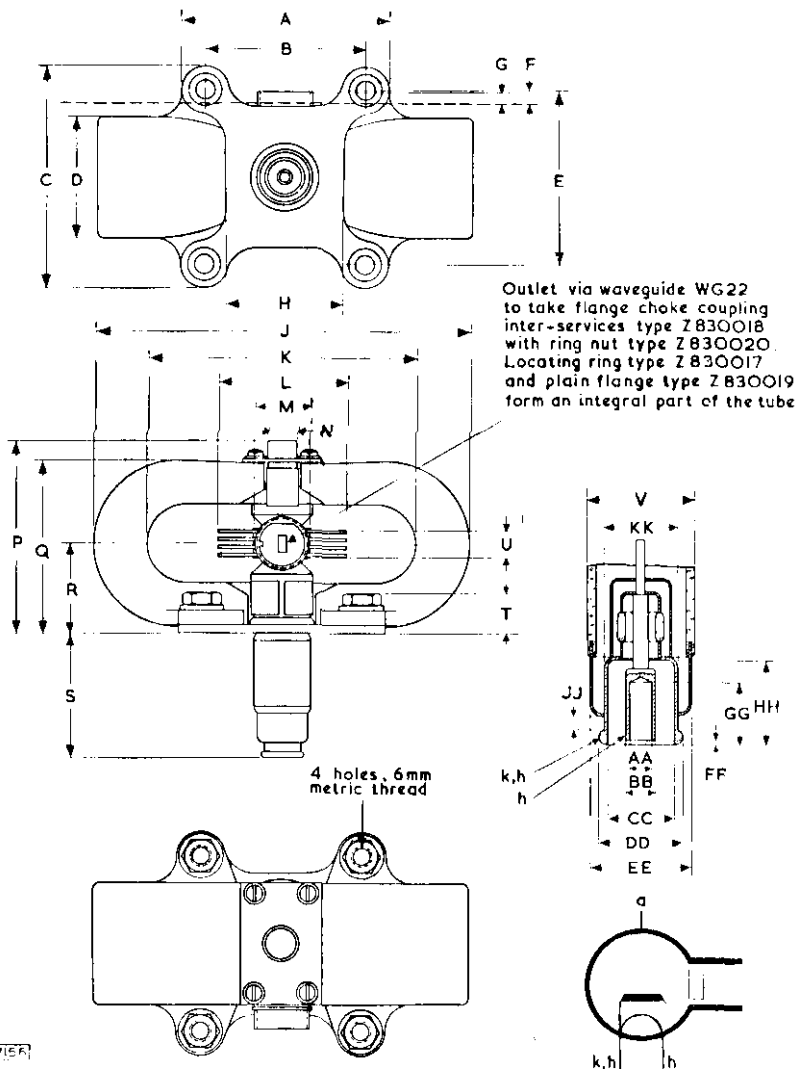

7156

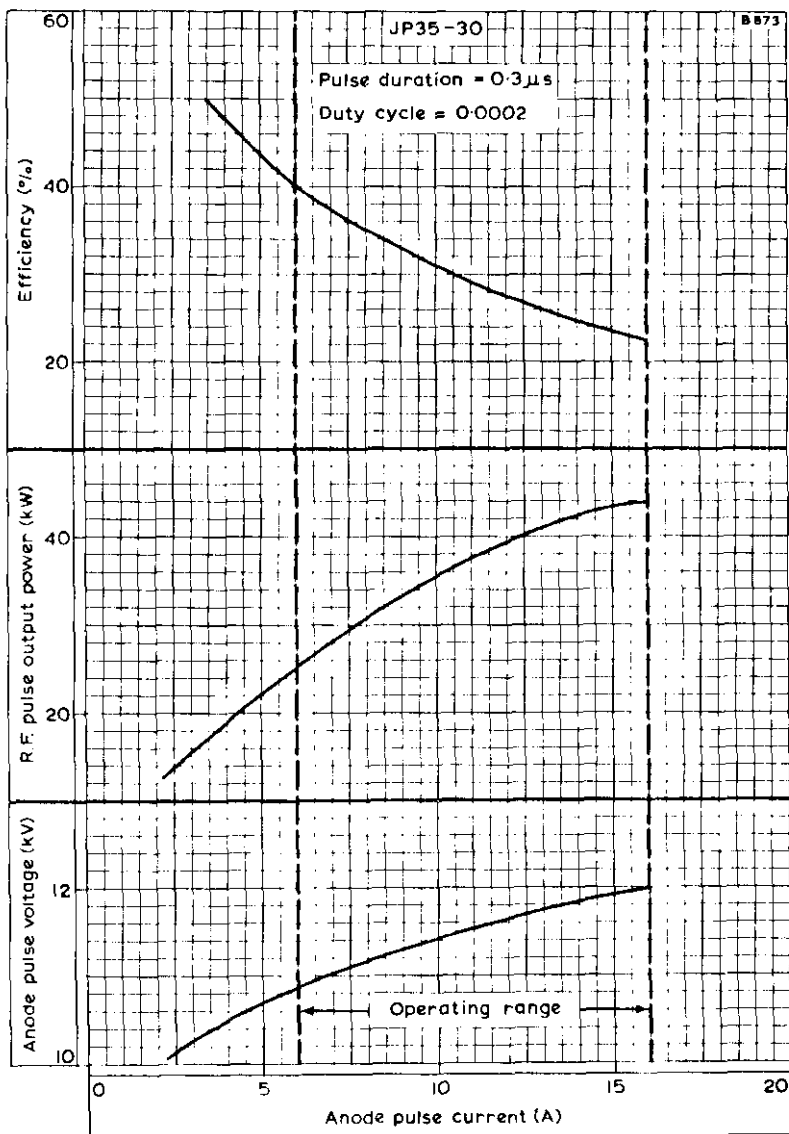

ANODE PULSE VOLTAGE, R.F. PULSE OUTPUT POWER AND EFFICIENCY
PLOTTED AGAINST ANODE PULSE CURRENT

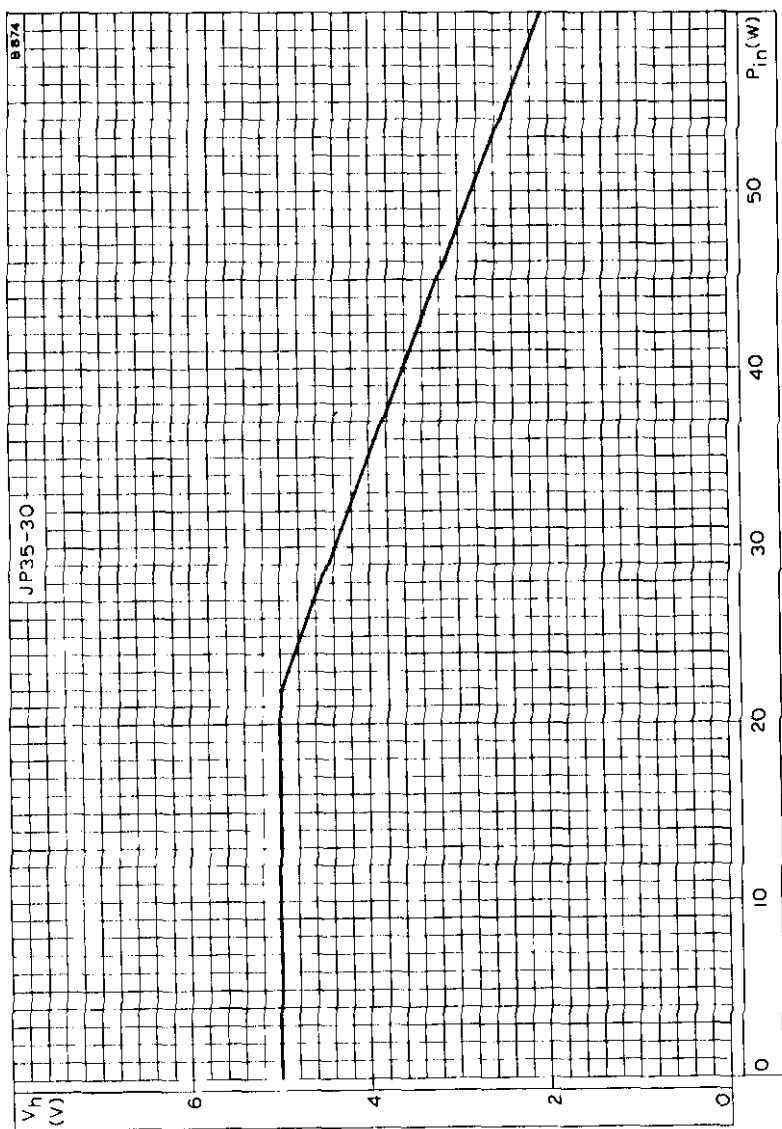

HEATER VOLTAGE PLOTTED AGAINST MEAN INPUT POWER
 MEAN INPUT POWER = MEAN INPUT CURRENT \times 12.500



TUNABLE MAGNETRON

JPG8-01 JPG8-01B
JPT8-01 JPT8-01B

Frequency: 'X' band, mechanically tunable.

Power output: 12W, c.w.

Construction: Packaged, forced-air cooled.

The only difference between the JPG8-01 and the JPT8-01 is in the mechanical tuning arrangement (see appropriate outline drawing). The suffix 'B' indicates a frequency variant of the basic type.

PRELIMINARY DATA

This data should be read in conjunction with GENERAL OPERATIONAL RECOMMENDATIONS - MICROWAVE DEVICES: INTRODUCTION and RADAR AND COMMUNICATION MAGNETRONS which precede this section of the handbook.

CHARACTERISTICS

Frequency	Min.		Max.	
Tunable over the range				
JPG8-01 JPT8-01	8.6	to	9.15	Gc/s
JPG8-01B JPT8-01B	8.0	to	8.6	Gc/s
Operating voltage ($I = 50\text{mA}$)	0.9		1.1	kV
R.F. power output ($I = 50\text{mA}$)	5.0		—	W
Frequency pulling factor	—		20	Mc/s
Frequency pushing factor	—		1.0	Mc/s per mA
Frequency temperature coefficient	—		-0.5	Mc/s per °C

CATHODE

Indirectly heated

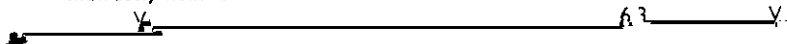

OPERATING NOTE

A limiting resistor of 1kΩ should be inserted in series with the magnetron.

COOLING

It is necessary to direct a flow of cooling air between the radiator fins in order to keep the temperature below the permitted maximum.

ABSOLUTE MAXIMUM RATINGS

	<i>Min.</i>	<i>Max.</i>	
Operating current (unmodulated c.w.)	20	60	mA
Peak operating current (modulated c.w.)	—	100	mA
Operating voltage	0.85	1.15	kV
Mean input power	—	60	W
Load mismatch (v.s.w.r.)	—	1.5	
Temperature of anode block	—	140	°C

MOUNTING POSITION

Any

MECHANICAL CHARACTERISTICS

	<i>Min.</i>	<i>Max.</i>	
Number of turns to cover the tuning range	4	8	
Tuning torque			
JPG8-01, JPG8-01B		16	oz in
JPT8-01, IPT8-01B		32	oz in
Tuning backlash		5	Mc/s

There is no limit to the number of tuning sweeps which may be carried out within the stated frequency range.

The JPG8-01 and JPG8-01B are intended for motor tuning.

PHYSICAL DATA

Weight of magnetron	{	1 lb 8 oz	
		680	g
Weight of magnetron in carton	{	2 lb 8 oz	
		1.13	kg
Dimensions of storage carton	{	5.0 × 7.0 × 7.5	in
		127 × 178 × 190	mm



OUTLINE DRAWING OF JPG8-01 AND JPG8-01B

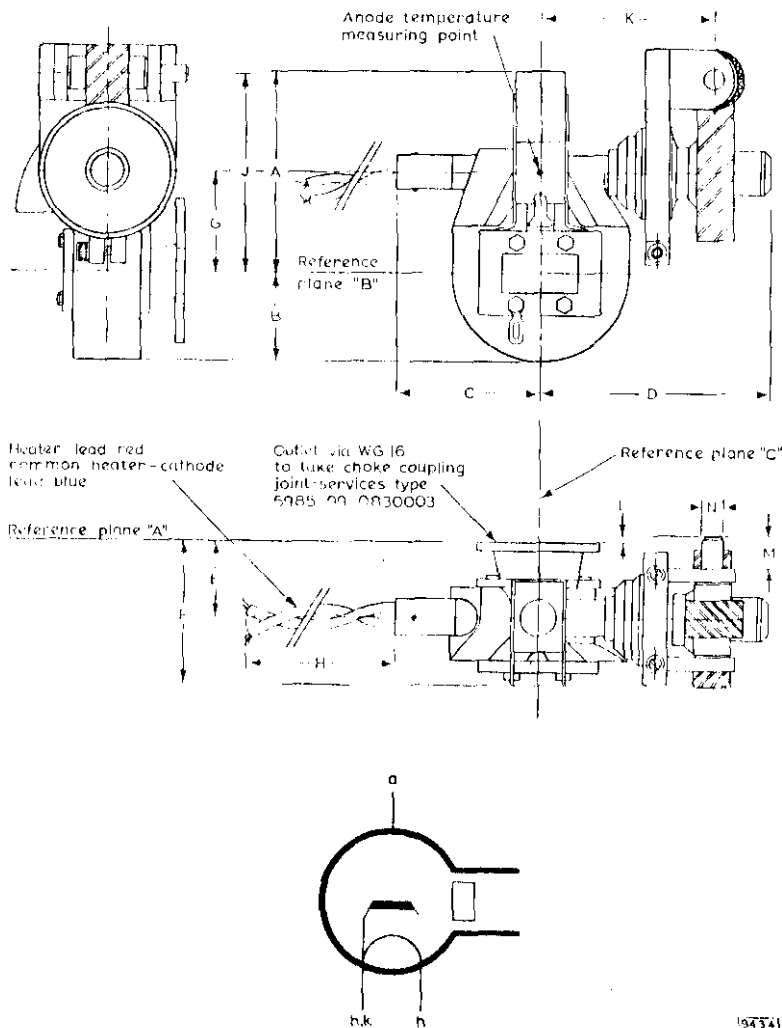

ANODE CONNECTION TERMINATED AT THE BASE PLATE

DIMENSIONS OF JPG8-01 AND JPG8-01B

	<i>Inches</i>	<i>Millimetres</i>	
A	2.56	65	max.
B	1.26	32	max.
C	1.97	50	max.
D	2.39	86	max.
E	0.965 ± 0.040	24.5 ± 1.0	
F	2.24	57	max.
G	1.223 ± 0.075	31 ± 2	
H	5.12 ± 0.20	130 ± 5	
J	2.463 ± 0.071	62.5 ± 2.0	
K	2.38 ± 0.10	60.5 ± 2.5	
L	0.098 ± 0.039	2.5 ± 1.0	
M	0.374 ± 0.020	9.5 ± 0.5	
N	0.247 ± 0.001	6.275 ± 0.025	

DIMENSIONS OF JPT8-01 AND JPT8-01B

	<i>Inches</i>	<i>Millimetres</i>	
A	2.56	65	max.
B	1.26	32	max.
C	1.97	50	max.
D	2.39	86	max.
E	0.965 ± 0.040	24.5 ± 1.0	
F	2.24	57	max.
G	1.223 ± 0.075	31 ± 2	
H	5.12 ± 0.20	130 ± 5	

OUTLINE DRAWING OF JPT8-01 AND JPT8-01B

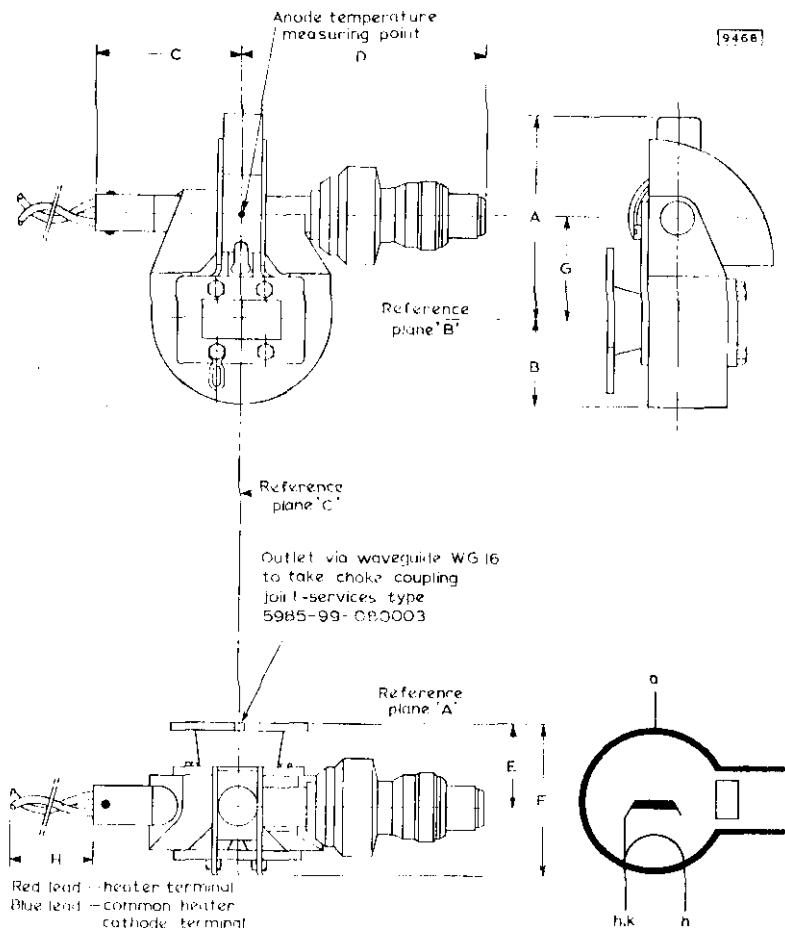

ANODE CONNECTION TERMINATED AT THE BASE PLATE

TUNABLE MAGNETRON

JPG8-01 JPG8-01B
JPT8-01 JPT8-01B

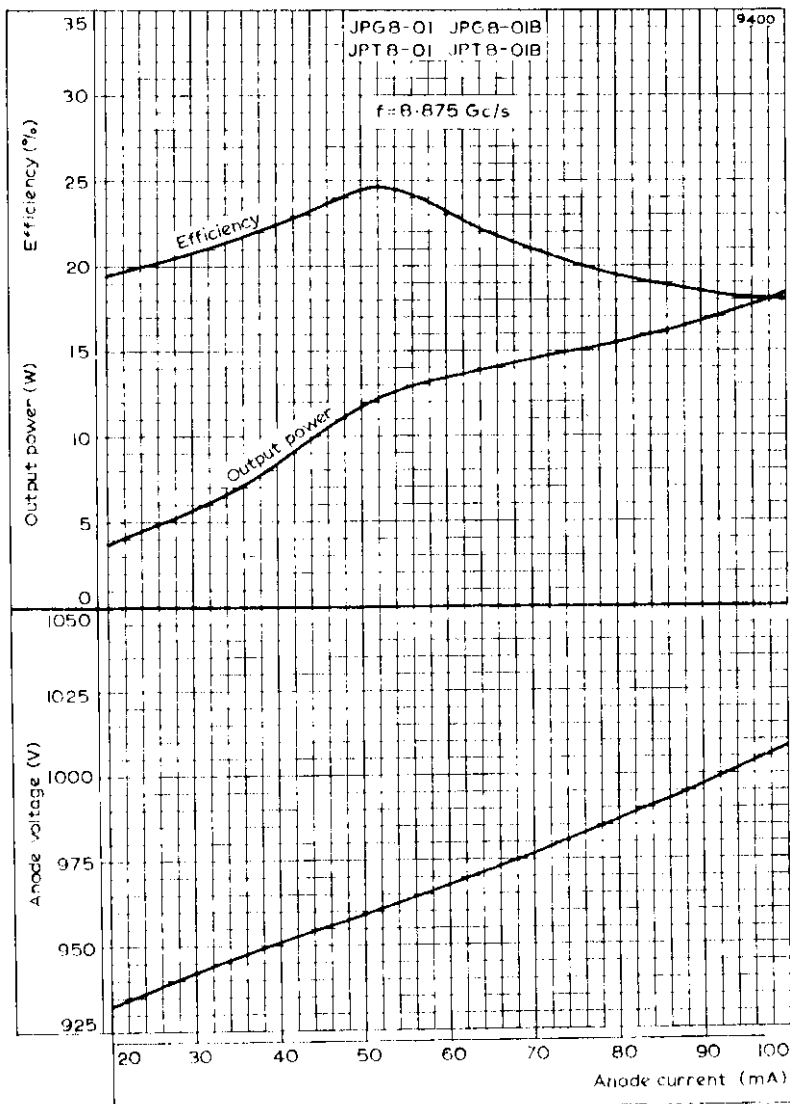

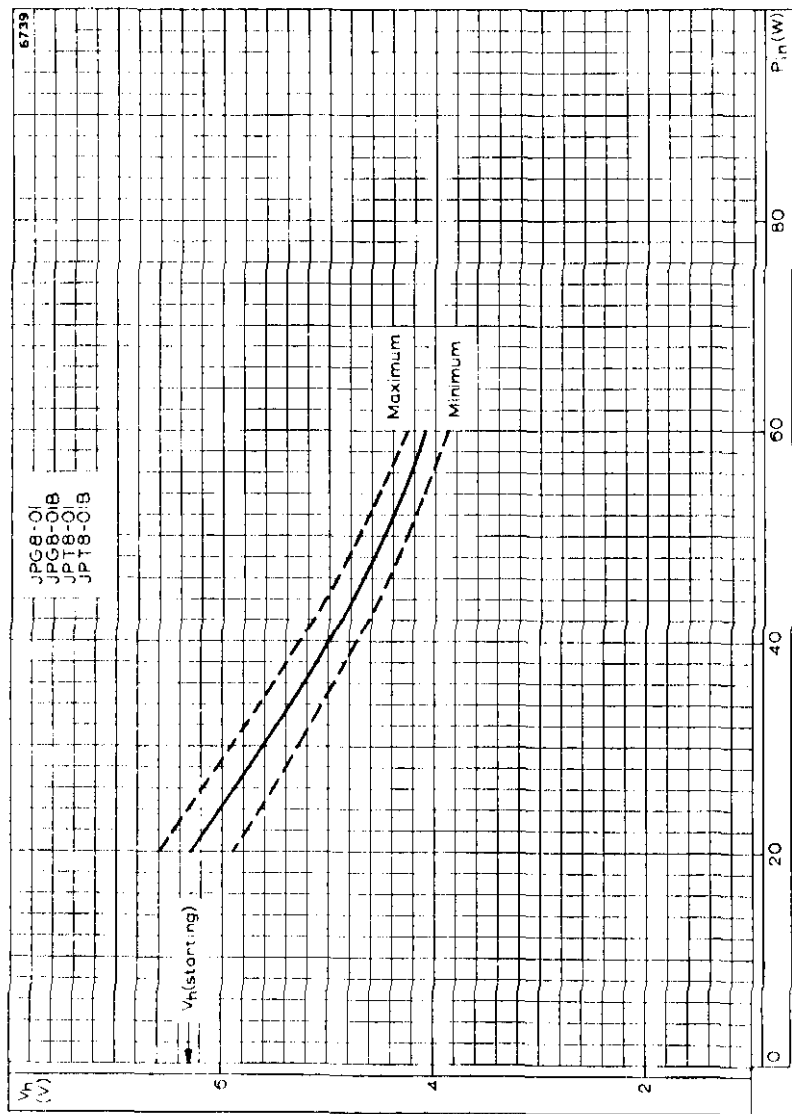

HEATER VOLTAGE PLOTTED AGAINST INPUT POWER

QUICK REFERENCE DATA

Mechanically and electronically tunable c.w. magnetrons

Frequency	JPG8-01E	8.62	Gc/s
	JPG9-01B	9.3	Gc/s
Power output		18	W
Construction	Packaged		

This data should be read in conjunction with GENERAL OPERATIONAL RECOMMENDATIONS - MICROWAVE DEVICES: INTRODUCTION and RADAR AND COMMUNICATION MAGNETRONS which precede this section of the handbook.

CHARACTERISTICS

	Min.	Max.	
Frequency			
Mechanically tunable over the range			
JPG8-01E	8.49	to 8.76	Gc/s
JPG9-01B	9.04	to 9.51	Gc/s
Operating voltage (I = 60mA)	910	1090	V
R.F. power output (I = 60mA)	11	—	W
R.F. power output (I = 30mA)	5.0	—	W
Electronic tuning rate			
(over current range 30mA-90mA)	0.25	1.5	Mc/s per mA
Electronic tuning			
(over current range 30mA-90mA)	25	—	Mc/s
Frequency temperature coefficient	—	-1.0	Mc/s per °C
Input capacitance	—	12	pF

CATHODE Indirectly heated

V_{ih}	6.3	V
I_{ih}	1.2	A

Heating time. At ambient temperatures above 0°C the cathode must be heated for at least 2 minutes before the application of h.t. Below this temperature the heating time must be increased to at least 3 minutes.

TYPICAL OPERATION

Frequency	Midband	
Heater voltage	6.3	V
Mean operating current	60	mA
Operating voltage	1.05	kV
Mean input power	63	W
Mean R.F. power output	18	W
Electronic tuning (over current range 30mA to 90mA)	32	Mc/s

JPG8-01E

JPG9-01B

MAGNETRON

ABSOLUTE MAXIMUM RATINGS

	Min.	Max.	
Mean operating current	30	60	mA
Modulated current excursion	30	95	mA
Mean input power	—	66	W
Load mismatch (v.s.w.r.)	—	1.2	
Temperature of anode block	—	140	°C

MECHANICAL CHARACTERISTICS

Tuning torque	16	oz in
Tuning backlash	5.0	Mc/s

The valve may be used with a pressurised system. At 30lb/in² the leakage rate will not exceed 0.0004lb/hr.

MOUNTING POSITION

Any

PHYSICAL DATA

Weight of magnetron	$\left. \begin{array}{l} 1 \text{ lb} \\ 730 \\ 2 \text{ lb} \\ 1.19 \end{array} \right\}$	10 oz
Weight of magnetron in carton		10 oz
Dimensions of storage carton	$\left\{ \begin{array}{l} 5.0 \times 7.0 \times 7.5 \\ 127 \times 178 \times 190 \end{array} \right.$	in
		mm

DIMENSIONS

	Inches	Millimetres	
A	2.56	65	max.
B	1.26	32	max.
C	1.97	50	max.
D	2.39	86	max.
E	0.531 ± 0.020	13.5 ± 0.5	
F	1.77	45	max.
G	1.220 ± 0.079	31 ± 2.0	
J	0 ± 0.079	0 ± 2.0	
K	2.382 ± 0.098	60.5 ± 2.5	
L	1.555 ± 0.020	39.5 ± 0.5	
M	0.374 ± 0.020	9.5 ± 0.5	
N	0.247 ± 0.001	6.275 ± 0.025	
Q	0.640	16.26	
R	0.610	15.49	

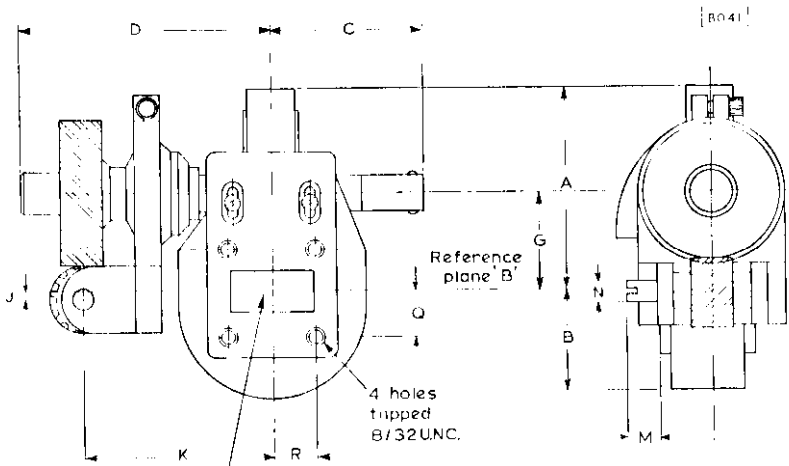

Output via WG 16 to take
bolted flange choke coupling
joint-services type
5985-09-0830051

Reference plane C

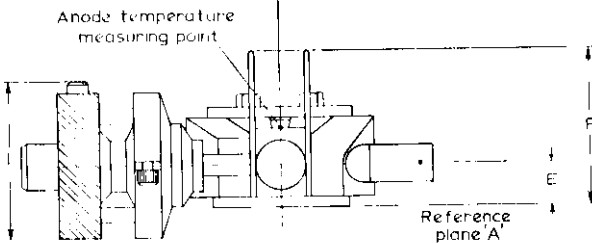
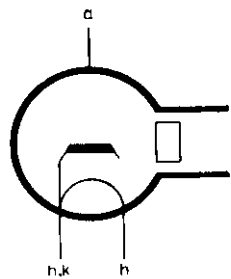

ANODE CONNECTION TERMINATED AT THE BASE PLATE

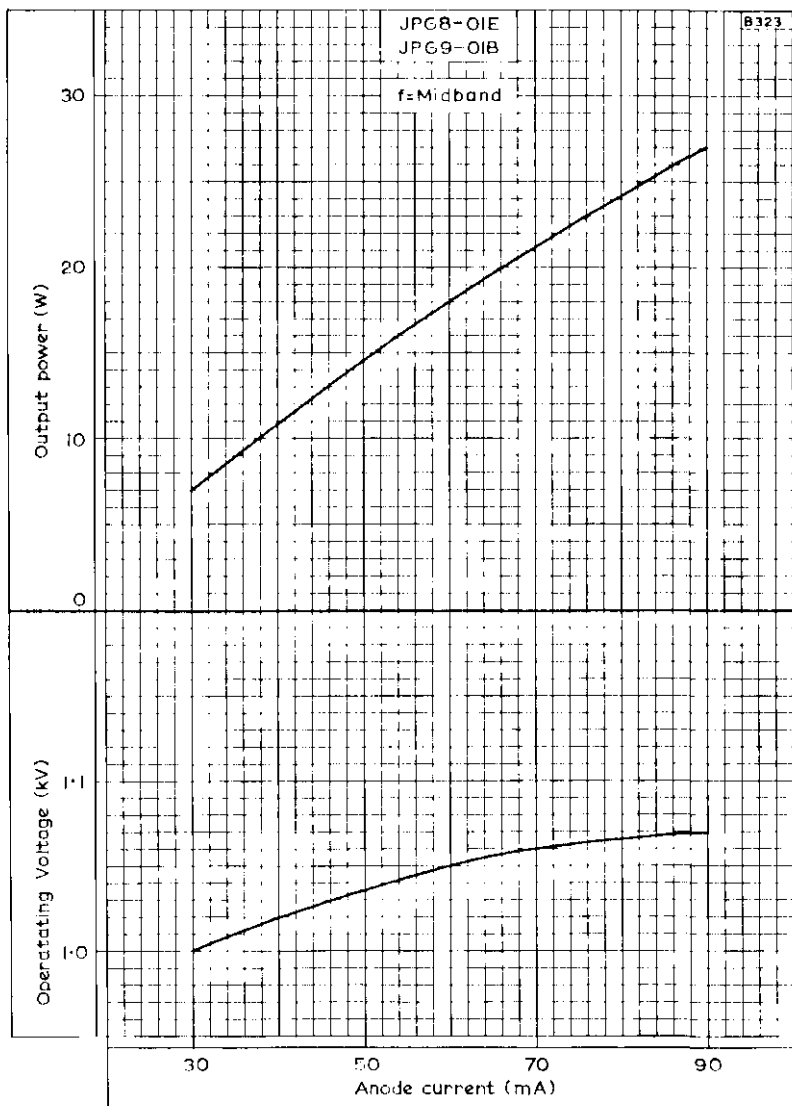

OPERATING VOLTAGE AND OUTPUT POWER PLOTTED AGAINST ANODE CURRENT

JPG8-01E JPG9-01B

MAGNETRON

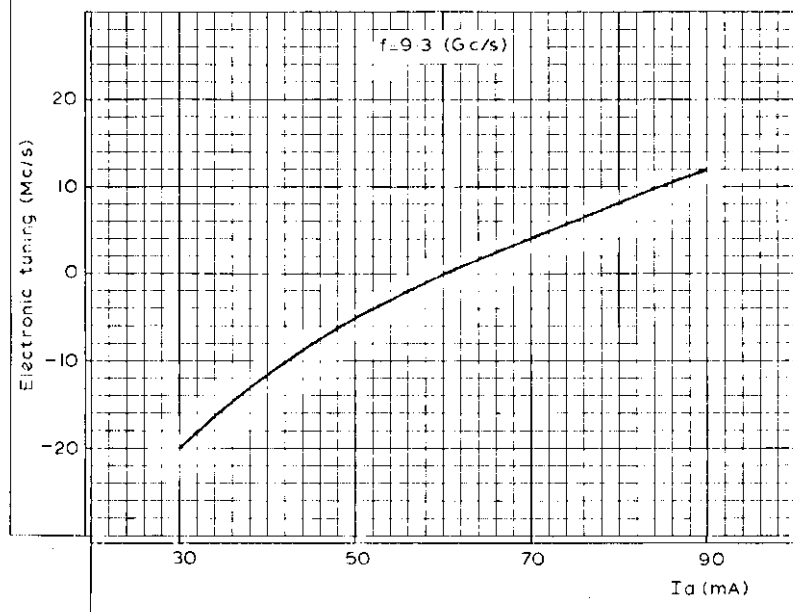
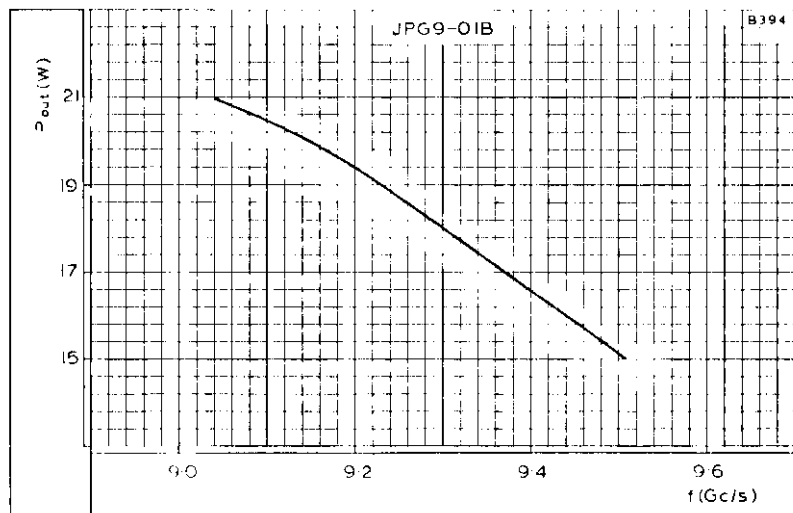

OUTPUT POWER PLOTTED AGAINST FREQUENCY AND ELECTRONIC TUNING PLOTTED AGAINST ANODE CURRENT

PRELIMINARY DATA

QUICK REFERENCE DATA

Tunable pulsed magnetrons intended for motor-driven tuning assemblies.

Frequency	JPG8-02B	8.75	Gc/s
	JPG9-02B	9.24	Gc/s
Power output		30	W
Construction		Packaged	

Unless otherwise shown data is applicable to both types

This data should be read in conjunction with GENERAL OPERATIONAL RECOMMENDATIONS - MICROWAVE DEVICES: INTRODUCTION and RADAR AND COMMUNICATION MAGNETRONS which precede this section of the handbook.

CHARACTERISTICS

	Min.	Max.	
Frequency			
Tunable over the range JPG8-02B	8.51 to	9.00	Gc/s
JPG9-02B	9.00 to	9.48	Gc/s
Pulse voltage ($I_{\text{pulse}} = 150\text{mA}$)	0.96	1.15	kV
R.F. pulse power output ($I_{\text{pulse}} = 150\text{mA}$)	25	—	W
Frequency pulling (v.s.w.r. = 1.5)	—	25	Mc/s
Frequency pushing factor ($I_{\text{pulse}} = 150\text{mA}$)	—	0.2	Mc/s per mA
Frequency temperature coefficient	—	-1.0	Mc/s per °C
Input capacitance	—	12	pF

CATHODE

Indirectly heated

V_h	6.3	V
I_h	1.2	A

Heating time. At ambient temperatures above 0°C the cathode must be heated for at least 2 minutes before the application of h.t. Below this temperature the heating time must be increased to at least 3 minutes.

TYPICAL OPERATION

Frequency	mid band	
Heater voltage (running)	6.3	V
Pulse duration	0.5	μs
Pulse repetition frequency	1000	p/s
Duty cycle	0.0005	
Pulse current	150	mA
Pulse voltage	1.05	kV
Pulse input power	158	W
R.F. pulse output power	30	W
Mean input current	75	μA
Mean input power	79	mW
Mean r.f. output power	15	mW
Frequency pulling (v.s.w.r. = 1.5)	18	Mc/s
Rate of rise of pulse voltage	5.0	kV/μs

ABSOLUTE MAXIMUM RATINGS

	<i>Min.</i>	<i>Max.</i>	
Pulse current	120	160	mA
Pulse duration	—	5.0	μ s
Duty cycle	—	0.05	
Mean input power	—	6.0	W
Rate of rise of voltage pulse	—	6.0	kV/ μ s
Load mismatch (v.s.w.r.)	—	1.5	
Temperature of anode block	—	140	$^{\circ}$ C

MECHANICAL CHARACTERISTICS

	<i>Min.</i>	<i>Max.</i>	
Tuning torque		32	oz In
Tuning backlash		5.0	Mc/s

There is no limit to the number of tuning sweeps which may be carried out within the stated frequency range.

The valve may be used with pressurised systems. At 30lb/in² the leakage rate will not exceed 0.0004lb/hr.

MOUNTING POSITION

Any

PHYSICAL DATA

Weight of magnetron	{ 11b 730	10oz g
Weight of magnetron in carton	{ 21b 1.19	10oz kg
Dimensions of storage carton	{ 5.0 x 7.0 x 7.5 127 x 178 x 190	in mm

DIMENSIONS

	<i>inches</i>	<i>Millimetres</i>	
A	2.56	65	max.
B	1.26	32	max.
C	1.97	50	max.
D	2.39	86	max.
E	0.964 ± 0.012	24.5 ± 0.3	
F	2.24	57	max.
G	1.240 ± 0.059	31.5 ± 1.5	

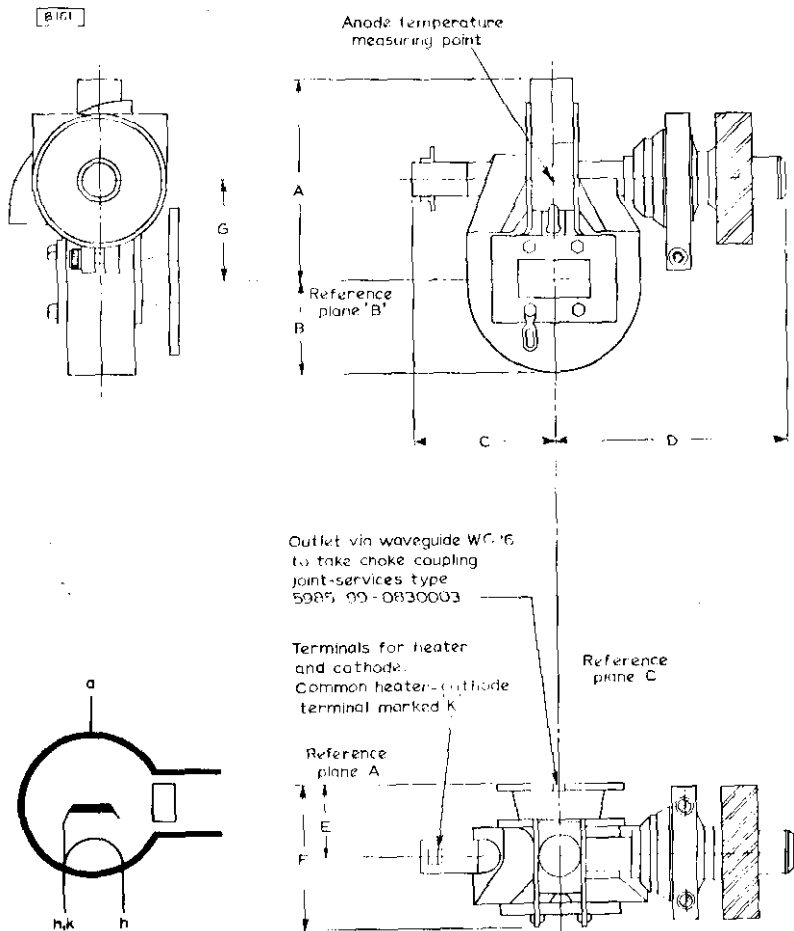

ANODE CONNECTION TERMINATED AT THE BASE PLATE

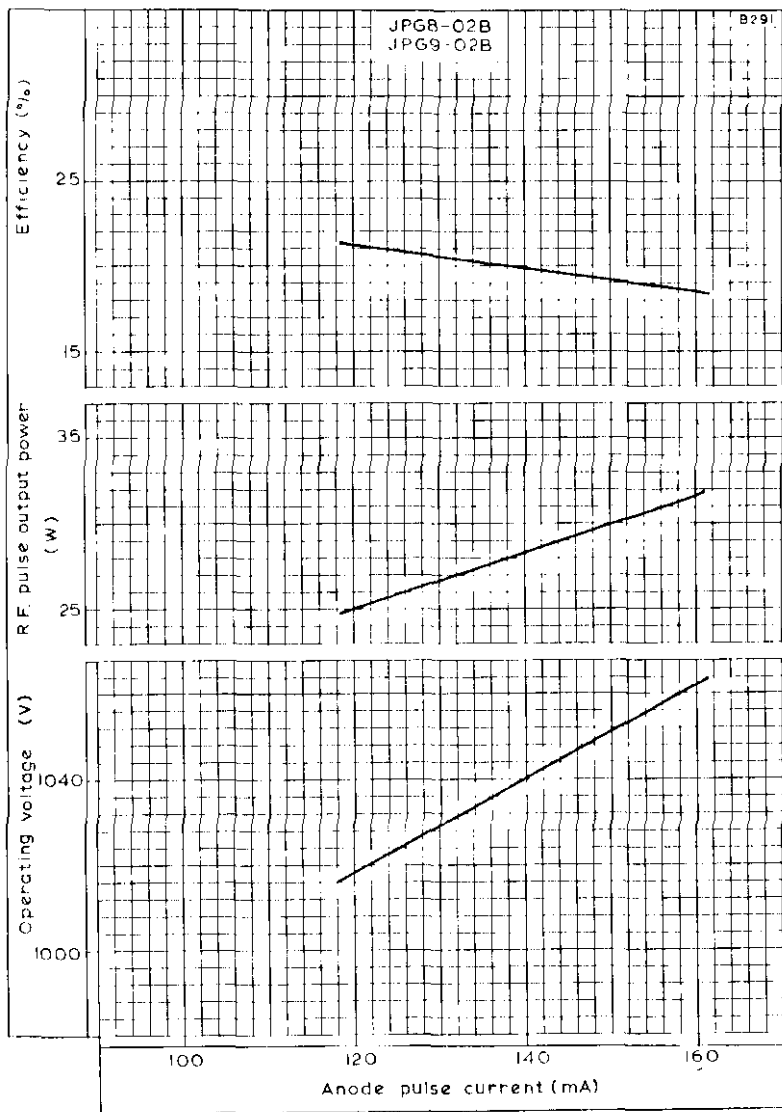

OPERATING VOLTAGE, R.F. PULSE OUTPUT POWER AND EFFICIENCY
PLOTTED AGAINST ANODE PULSE CURRENT

TUNABLE MAGNETRON

Frequency: 'X' band, mechanically tunable.

Power output: 10W, c.w.

Construction: Packaged, forced-air cooled.

JPG9-01

JPT9-01

The only difference between the JPG9-01 and the JPT9-01 is in the mechanical tuning arrangement (see appropriate outline drawing)

This data should be read in conjunction with GENERAL OPERATIONAL RECOMMENDATIONS - MICROWAVE DEVICES: INTRODUCTION and RADAR AND COMMUNICATION MAGNETRONS which precede this section of the handbook.

CHARACTERISTICS

Frequency	Min.	Max.	
Tunable over the range	9.15	to 9.6	Gc/s
Operating voltage (I = 50mA)	0.9	to 1.1	kV
R.F. power output (I = 50mA)	5.0	—	W
Frequency pulling factor (v.s.w.r. = 1.5)	—	20	Mc/s
Frequency pushing factor	—	1.0	Mc/s per mA
Frequency temperature coefficient	—	-0.5	Mc/s per °C

CATHODE

Indirectly heated

V_{II}	6.3	V
I_{II}	1.2	A

Heating time. At ambient temperatures above 0°C the cathode must be heated for at least 2 minutes before the application of h.t. Below this temperature the heating time must be increased to at least 3 minutes. For mean input powers greater than 20 watts it is necessary to reduce the heater voltage immediately after application of h.t. in accordance with the input power-heater voltage rating chart on page C3.

TYPICAL OPERATION

Frequency	9.2	9.4	9.55	Gc/s
Heater voltage (running)	4.5	4.5	4.5	V
Operating voltage	920	930	930	V
Operating current	50	50	50	mA
Input power	46	46	46	W
R.F. power output	10.5	10.5	9.8	W
Frequency pulling (v.s.w.r. = 1.5)	19	16	14	Mc/s

OPERATING NOTE

A limiting resistor of 1k Ω should be inserted in series with the magnetron.

COOLING

It is necessary to direct a flow of cooling air of at least 5 cu. ft. per minute between the radiator fins in order to keep the temperature below the permitted maximum.

JPG9-01

JPT9-01

TUNABLE MAGNETRON

ABSOLUTE MAXIMUM RATINGS

	<i>Min.</i>	<i>Max.</i>	
Operating current (unmodulated c.w.)	20	60	mA
Peak operating current (modulated c.w.)	—	100	mA
Operating voltage (modulated c.w.)	0.85	1.15	kV
Mean input power	—	60	W
Load mismatch (v.s.w.r.)	—	1.5	
Temperature of anode block	—	140	°C

MECHANICAL CHARACTERISTICS

	<i>Min.</i>	<i>Max.</i>	
Number of turns to cover the tuning range	4	8	
Tuning torque			
JPG9-01	—	16	oz in
JPT9-01	—	32	oz in
Tuning backlash	—	5	Mc/s

There is no limit to the number of tuning sweeps which may be carried out within the stated frequency range.

The JPG9-01 is intended for motor tuning.

PHYSICAL DATA

Weight of magnetron	{ 1 lb 8 oz 680 g
Weight of magnetron in carton	{ 2 lb 8 oz 1.13 kg
Dimensions of storage carton	{ 5.0 × 7.0 × 7.5 in 127 × 178 × 190 mm

DIMENSIONS OF JPT9-01

	<i>Inches</i>	<i>Millimetres</i>	
A	2.56	65	max.
B	1.26	32	max.
C	1.97	50	max.
D	2.39	86	max.
E	0.965 ± 0.040	24.5 ± 1.0	
F	2.24	57	max.
G	1.223 ± 0.075	31 ± 2	
H	5.12 ± 0.20	130 ± 5	



OUTLINE DRAWING OF JPT9-01

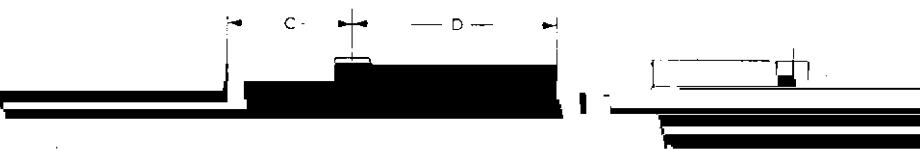

1

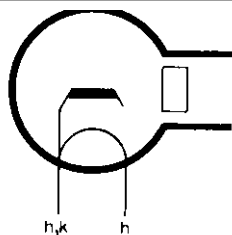
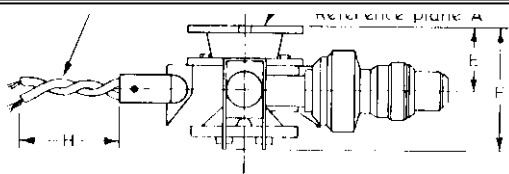

3472

ANODE CONNECTION TERMINATED AT THE BASE PLATE

DIMENSIONS OF JPG9-01

←

	<i>Inches</i>	<i>Millimetres</i>
A	2.56	65
B	1.26	32
C	1.97	50
D	2.39	86
E	0.965 ± 0.040	24.5 ± 1.0
F	2.24	57
G	1.223 ± 0.075	31 ± 2
H	5.12 ± 0.20	130 ± 5
J	2.463 ± 0.071	62.5 ± 2.0
K	2.38 ± 0.10	60.5 ± 2.5
L	0.098 ± 0.039	2.5 ± 1.0
M	0.374 ± 0.020	9.5 ± 0.5
N	0.247 ± 0.001	6.275 ± 0.025

OUTLINE DRAWING OF JPG9-01

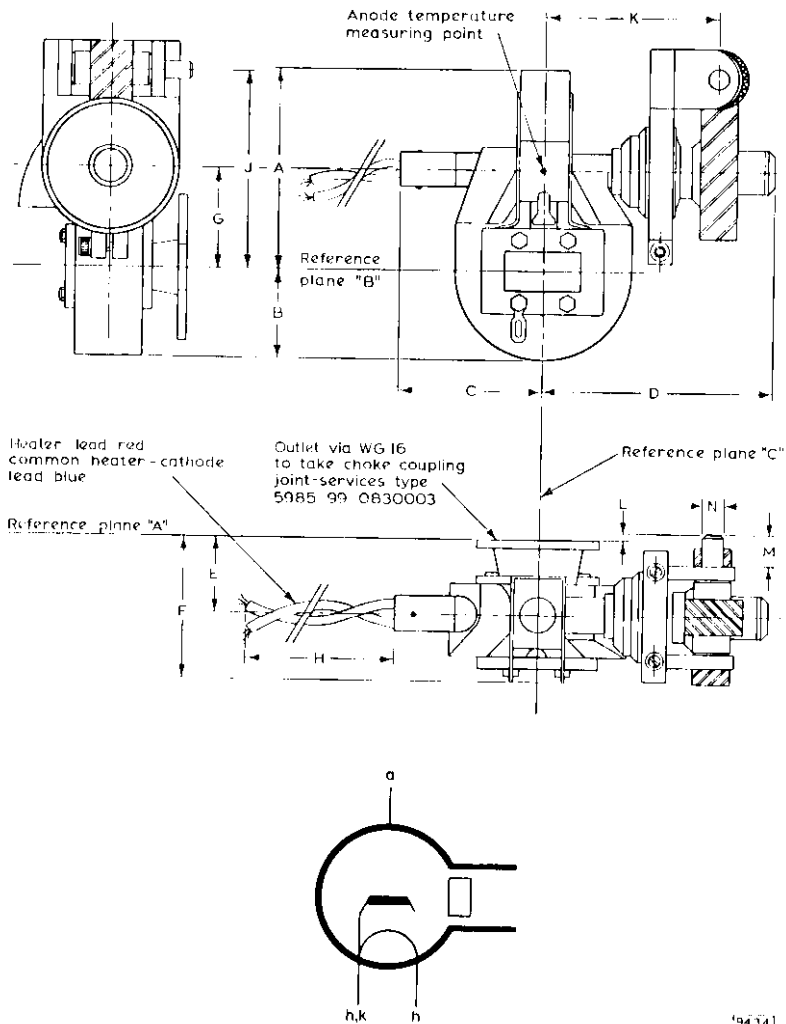

ANODE CONNECTION TERMINATED AT THE BASE PLATE

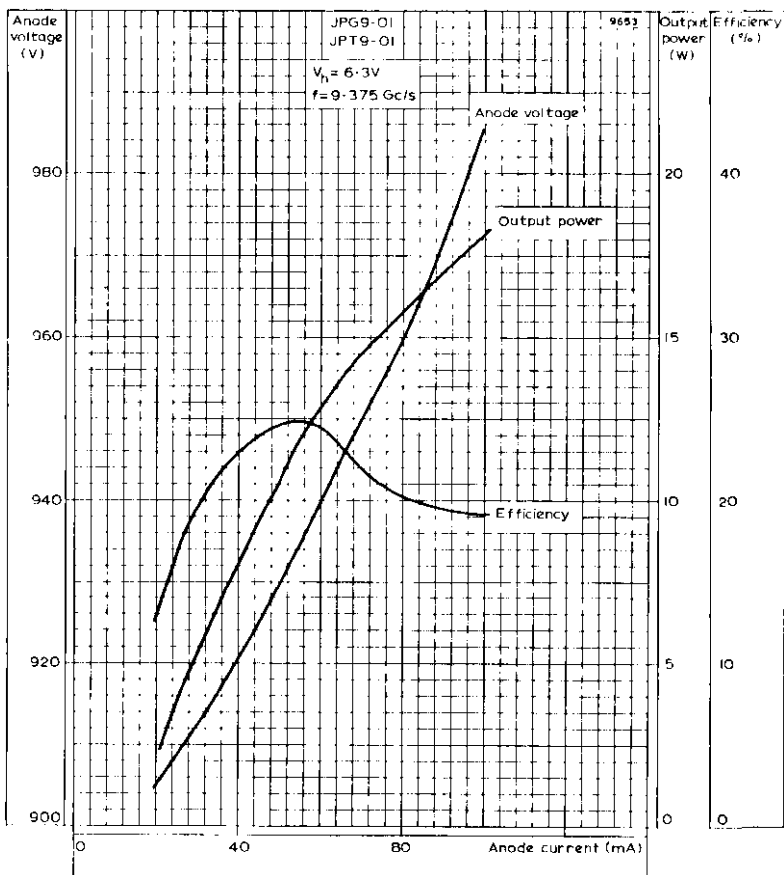

ANODE VOLTAGE, OUTPUT POWER AND EFFICIENCY PLOTTED AGAINST ANODE CURRENT



ANODE VOLTAGE, R.F. OUTPUT POWER AND FREQUENCY PULLING
PLOTTED AGAINST FREQUENCY

TUNABLE MAGNETRON

Frequency: 'X' band, mechanically tunable.

Power output: 25W, pulsed.

Construction: Packaged.

JPG9-02

JPT9-02

The only difference between the JPG9-02 and the JPT9-02 is in the mechanical tuning arrangement (see appropriate outline drawing)

This data should be read in conjunction with GENERAL OPERATIONAL RECOMMENDATIONS - MICROWAVE DEVICES: INTRODUCTION and RADAR AND COMMUNICATION MAGNETRONS which precede this section of the handbook.

CHARACTERISTICS

	Min.	Max.	
Frequency			
Tunable over the range	9.15 to	9.6	Gc/s
Pulse voltage ($I_{\text{pulse}} = 120\text{mA}$)	0.95	1.15	kV
R.F. pulse power output ($I_{\text{pulse}} = 120\text{mA}$)	18	—	W
Frequency pulling factor (v.s.w.r. = 1.5)	—	20	Mc/s
Frequency pushing factor ($I_{\text{pulse}} = 140\text{mA}$)	—	0.2	Mc/s per mA
Frequency temperature coefficient	—	-0.5	Mc/s per °C
Input capacitance	—	12	pF

CATHODE

Indirectly heated

V_h	6.3	V
I_h	1.2	A

Heating time At ambient temperatures above 0°C the cathode must be heated for at least 2 minutes before the application of h.c. Below this temperature the heating time must be increased to at least 3 minutes.

TYPICAL OPERATION

Frequency	9.2	9.4	9.55	Gc/s
Heater voltage (running)	6.3	6.3	6.3	V
Pulse duration	0.5	0.5	0.5	μs
Pulse repetition frequency	1000	1000	1000	p/s
Duty cycle	0.0005	0.0005	0.0005	
Pulse current	120	120	120	mA
Pulse voltage	0.97	1.0	1.0	kV
Pulse input power	120	120	120	W
R.F. pulse output power	22	25	24	W
Mean input current	60	60	60	μA
Mean input power	60	60	60	mW
Mean r.f. output power	11	12.5	12	mW
Frequency pulling (v.s.w.r. 1.5)	19	16	14	Mc/s
Rate of rise of pulse voltage	5.0	5.0	5.0	kV/μs

ABSOLUTE MAXIMUM RATINGS

	Min.	Max.	
Pulse current	50	150	mA
Pulse voltage	0.9	1.15	kV
Pulse duration	—	5.0	μs
Duty cycle	—	0.05	
Mean input power	—	6.0	W
Rate of rise of voltage pulse	—	6.0	kV/μs
Load mismatch (v.s.w.r.)	—	1.5	
Temperature of anode block	—	140	°C

MECHANICAL CHARACTERISTICS

	Min.	Max.	
Number of turns to cover the tuning range	4	8	
Tuning torque	—	16	oz in
		32	oz in
Tuning backlash	—	5.0	Mic's

There is no limit to the number of tuning sweeps which may be carried out within the stated frequency range.

The JPG9-02 is intended for motor tuning.

PHYSICAL DATA

Weight of magnetron	{ 1 lb 8 oz 680	g
Weight of magnetron in carton	{ 2 lb 8 oz 1.13	kg
Dimensions of storage carton	{ 5.0 × 7.0 × 7.5 127 · 178 · 190	in mm

DIMENSIONS OF JPT9-02

	Inches	Millimetres	
A	2.56	65	max.
B	1.26	32	max.
C	1.97	50	max.
D	2.39	86	max.
E	0.965 ± 0.040	24.5 ± 1.0	
F	2.24	57	max.
G	1.223 ± 0.075	31 ± 2	
H	5.12 ± 0.20	130 ± 5	



OUTLINE DRAWING OF JPT9-02

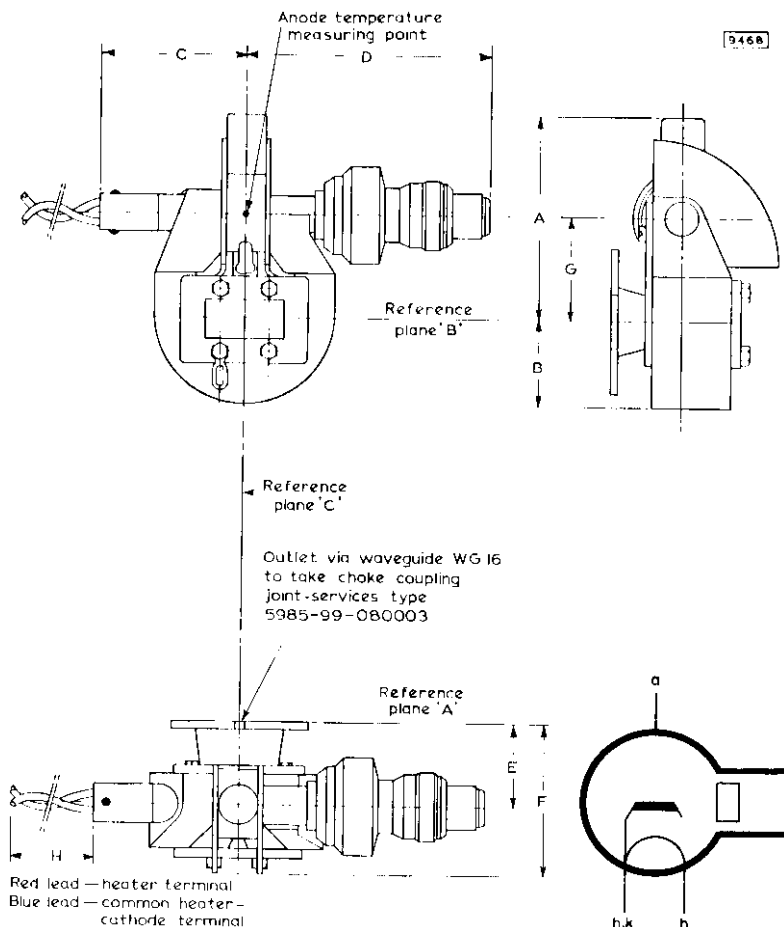

ANODE CONNECTION TERMINATED AT THE BASE PLATE

JPG9-02

JPT9-02

TUNABLE MAGNETRON

DIMENSIONS OF JPG9-02



	<i>Inches</i>	<i>Millimetres</i>	
A	2.56	65	max.
B	1.26	32	max.
C	1.97	50	max.
D	2.39	86	max.
E	0.965 ± 0.040	24.5 ± 1.0	
F	2.24	57	max.
G	1.223 ± 0.075	31 ± 2	
H	5.12 ± 0.20	130 ± 5	
J	2.463 ± 0.071	62.5 ± 2	
K	2.38 ± 0.10	60.5 ± 2.5	
L	0.098 ± 0.039	2.5 ± 1.0	
M	0.374 ± 0.020	9.5 ± 0.5	
N	0.247 ± 0.001	6.275 ± 0.025	



OUTLINE DRAWING OF JPG9-02

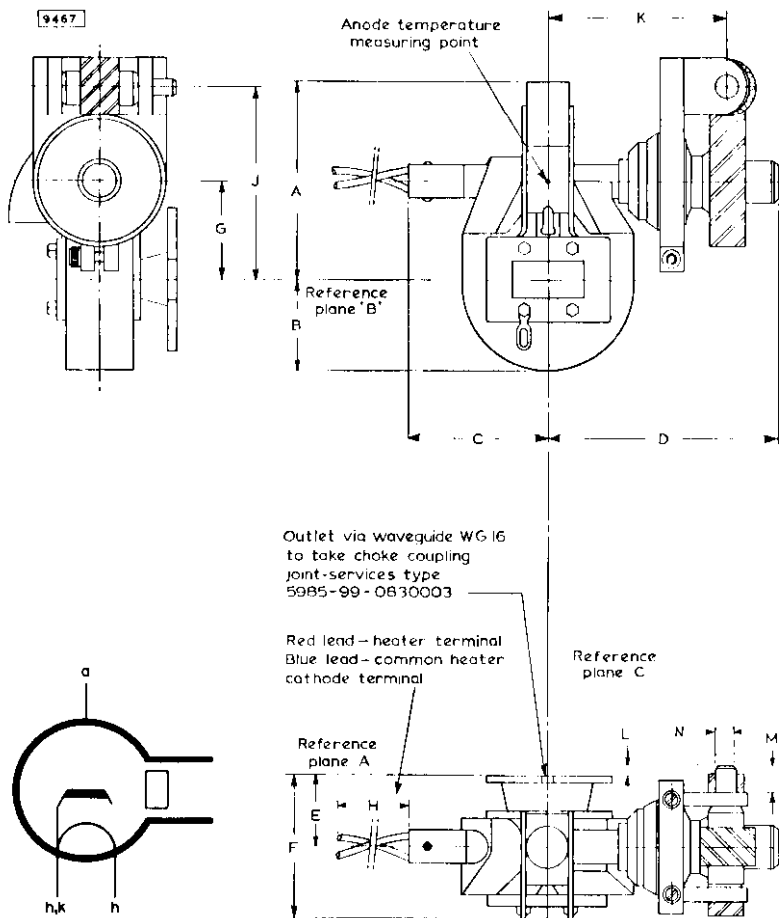

ANODE CONNECTION TERMINATED AT THE BASE PLATE

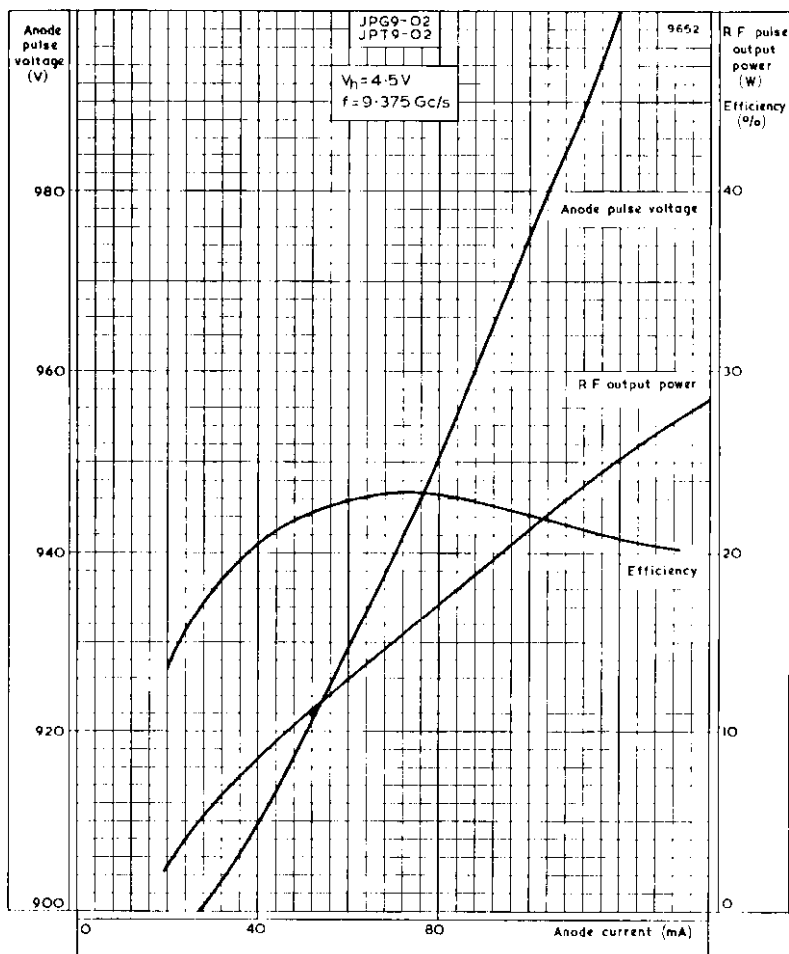

ANODE PULSE VOLTAGE, R.F. PULSE OUTPUT POWER AND EFFICIENCY PLOTTED AGAINST ANODE CURRENT

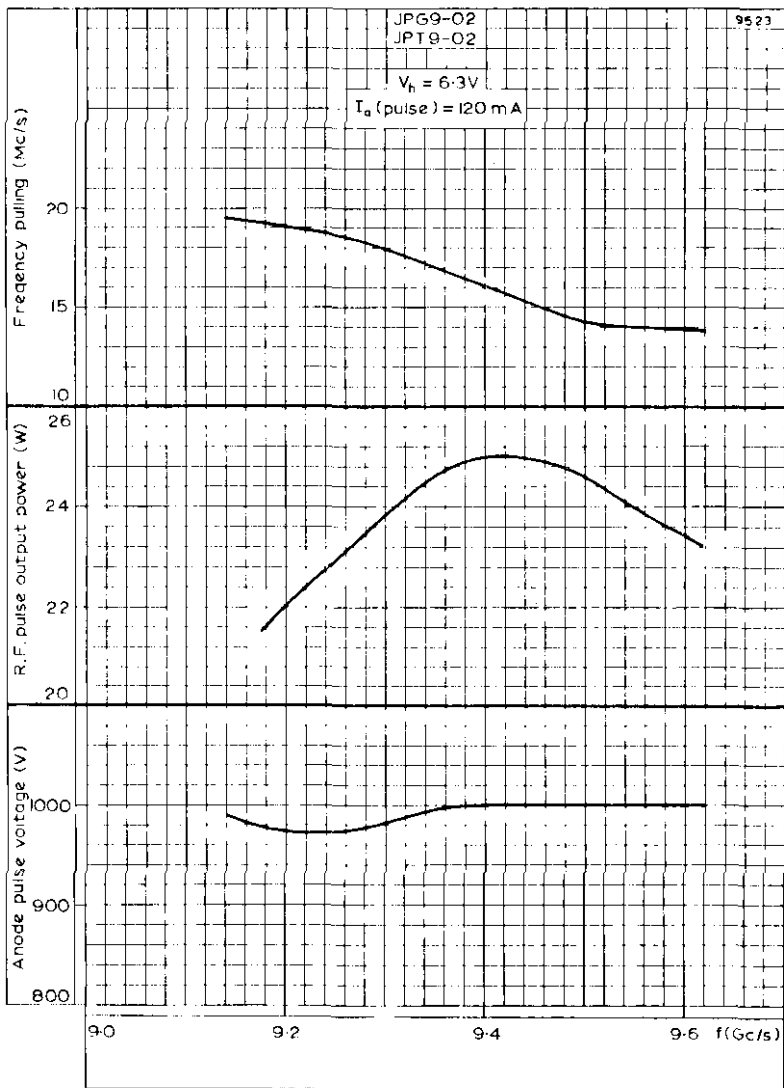

ANODE PULSE VOLTAGE, R.F. PULSE OUTPUT POWER AND FREQUENCY PULLING PLOTTED AGAINST FREQUENCY



PRELIMINARY DATA

QUICK REFERENCE DATA

Mechanically tunable pulsed magnetron

Frequency	9.4	Gc/s
Pulsed power output	25	W
Construction	Packaged, low stray radiation, suitable for motor tuning.	

This data should be read in conjunction with GENERAL OPERATIONAL RECOMMENDATIONS - MICROWAVE DEVICES: INTRODUCTION and RADAR AND COMMUNICATION MAGNETRONS which precede this section of the handbook.

CHARACTERISTICS

	Min.	Max.	
Frequency			
Tunable over the range	9.15 to	9.55	Gc/s
Pulse voltage ($I_{\text{pulse}} = 140\text{mA}$)	0.95	1.15	kV
R.F. pulse power output ($I_{\text{pulse}} = 140\text{mA}$)	18	—	W
Frequency pulling factor (v.s.w.r. = 1.5)	—	20	Mc/s
Frequency pushing factor ($I_{\text{pulse}} = 140\text{mA}$)	—	0.2	Mc/s per mA
Frequency temperature coefficient	—	-1.0	Mc/s per °C
Input capacitance	—	12	pF
Peak r.f. leakage power	—	2.5	μW

CATHODE

Indirectly heated

V_h	6.3	V
I_h	1.2	A

Heating time. At ambient temperatures above 0°C the cathode must be heated for at least 2 minutes before the application of h.t. Below this temperature the heating time must be increased to at least 3 minutes.

TYPICAL OPERATION

f	9.4	Gc/s
Heater voltage	6.3	V
Pulse duration	0.5	μ s
Pulse repetition frequency	1000	p/s
Duty cycle	0.0005	
Pulse current	140	mA
Pulse voltage	1.02	kV
Pulse input power	143	W
R.F. pulse output power	25	W
Mean input current	70	μ A
Mean input power	71	mW
Mean r.f. output power	12.5	mW
Frequency pulling (v.s.w.r. = 1.5)	16	Mc/s
Rate of rise of pulse voltage	5.0	kV/ μ s

ABSOLUTE MAXIMUM RATINGS

	Min.	Max	
Pulse current	100	150	mA
Pulse duration	—	5.0	μ s
Duty cycle	—	0.05	
Mean input power	—	6.0	W
Rate of rise of voltage pulse	—	6.0	kV/ μ s
Load mismatch (v.s.w.r.)	—	1.5	
Temperature of anode block	—	140	$^{\circ}$ C

MECHANICAL CHARACTERISTICS

	Min.	Max.	
Number of turns of drive shaft to cover the tuning range	10	20	
Tuning torque	—	16	oz in
Tuning backlash	—	5.0	Mc/s

There is no limit to the number of tuning sweeps which may be carried out within the stated frequency range.

MOUNTING POSITION

Any

PHYSICAL DATA

Weight of magnetron	{ 1 lb 730	10 oz g
Weight of magnetron in carton	{ 2 lb 1.19	10 oz kg
Dimensions of storage carton	{ 5.0 x 7.0 x 7.5 127 x 178 x 190	in mm

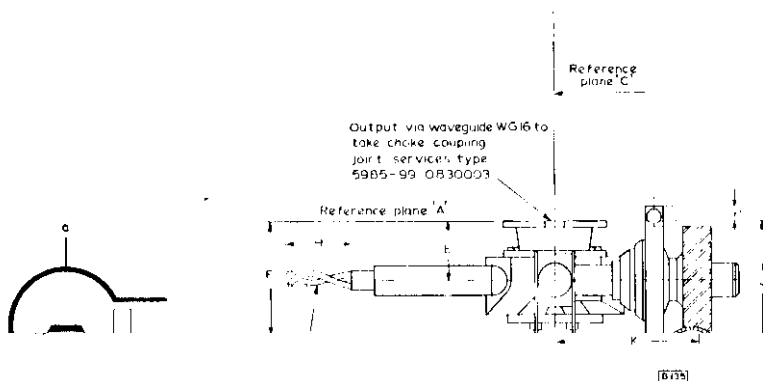
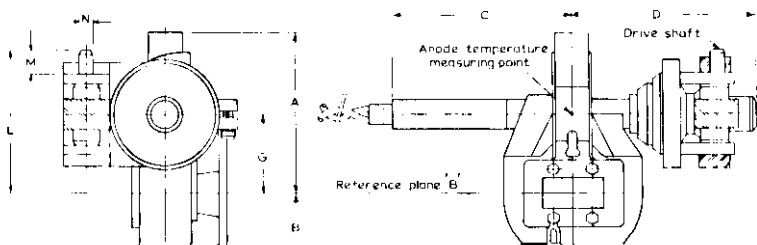

ANODE CONNECTION TERMINATED AT THE BASE PLATE

DIMENSIONS

	Inches	Millimetres	
A	2.56	65	max.
B	1.26	32	max
C	5.51 ± 0.16	104 ± 4.0	
D	2.39	86	max
E	0.96 ± 0.04	24.5 ± 1.0	
F	2.24	57	max
G	1.220 ± 0.079	31 ± 2.0	
H	5.12 ± 0.20	130 ± 5.0	
J	2.20 ± 0.04	56 ± 1.0	
K	2.382 ± 0.098	60.5 ± 2.5	
L	2.283 ± 0.079	58 ± 2.0	
M	0.374 ± 0.02	9.5 ± 0.5	
N	0.247 ± 0.001	6.275 ± 0.025	
P	0.315	8.0	max.

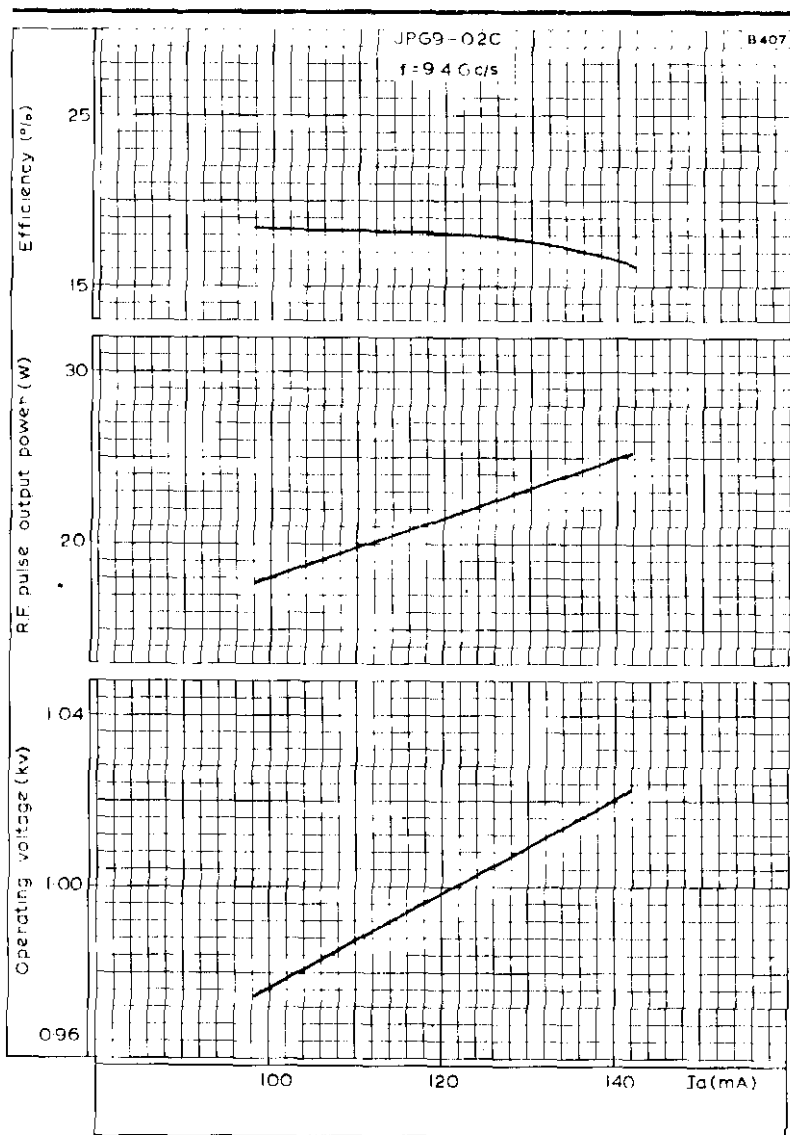

OPERATING VOLTAGE, R.F. PULSE OUTPUT POWER AND EFFICIENCY
PLOTTED AGAINST ANODE CURRENT

QUICK REFERENCE DATA

Packaged magnetron with push-rod tuning mechanism for rapid frequency sweeping.

Frequency	9.32 to 9.5	GHz
Power output (pulsed)	15	W

To be read in conjunction with
GENERAL OPERATIONAL RECOMMENDATIONS - MICROWAVE DEVICES

OPERATING CONDITIONS

R. F. pulse power output	15	W
Duty factor	0.11	
Pulse duration	45	μ s
Pulse repetition frequency	2500	p.p.s.
Heater voltage (running)	6.3	V
Pulse current	100	mA
Pulse voltage	1.0	kV
Pulse input power	100	W
Rate of rise of voltage pulse	5.0	kV/ μ s
Mean r.f. output power	1.65	W
Frequency pulling (v.s.w.r. = 1.5)	16	MHz
Swept over the range	9.32 to 9.50	GHz

CATHODE

Indirectly heated

V_h	6.3	V
I_h	1.2	A

Heating time. At ambient temperatures above 0°C the cathode must be heated for at least 2 minutes before the application of h.t. Below this temperature the heating time must be increased to at least 3 minutes.

CHARACTERISTICS

	Min.	Typ.	Max.	
Frequency tunable over the range	9.32	-	9.50	GHz
Pulse voltage ($I_{\text{pulse}} = 100\text{mA}$)	0.9	-	1.1	kV
R. F. pulse power output ($I_{\text{pulse}} = 100\text{mA}$)	12	-	-	W
Frequency pulling (v. s. w. r. = 1.5)	-	-	20	MHz
Frequency temperature coefficient	-	-	-0.5	MHz per degC
Input capacitance	-	-	12	pF
Frequency pushing ($I_{\text{pulse}} = 100\text{mA}$)	-	0.3	-	MHz per A

RATINGS (ABSOLUTE MAXIMUM SYSTEM)

	Min.	Max.	
Pulse current	60	140	mA
Pulse duration	-	50	μs
Duty factor	-	0.25	
Mean input power	-	60	W
Rate of rise of voltage pulse	-	10	kV/ μs
Load mismatch (v. s. w. r.)	-	1.5	
Temperature of anode block	-	120	$^{\circ}\text{C}$

MECHANICAL CHARACTERISTICS

	Min.	Max.	
Movement of push rod to cover tuning range	0.127	0.254	mm
	0.005	0.01	in

The tuning mechanism is designed for cam operation and may require 6.35kg (14lb) thrust for operation.

There is no limit to the number of tuning sweeps which may be carried out within the stated frequency range,

MOUNTING POSITION

Any

PHYSICAL DATA

	kg	lb
Weight of magnetron	0.74	1.63
Weight of magnetron in carton	1.19	2.63
	mm	in
Dimensions of storage carton	127 × 178 × 190	5.0 × 7.0 × 7.5

OUTLINE DRAWING

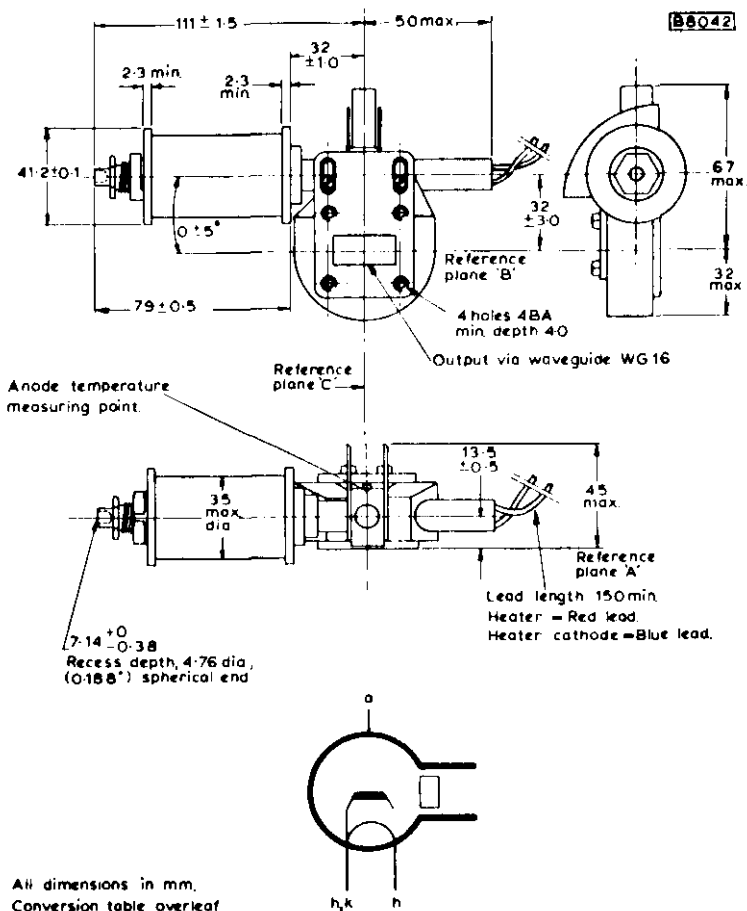

DIMENSION CONVERSION TABLE

Millimetres	Inches	
2.3	0.090	min
7.14 ⁺⁰ -0.38	0.281 ⁺⁰ - 0.015	
13.5 ±0.5	0.531 ± 0.019	
32 ±3.0	1.259 ± 0.118	
32 ±1.0	1.259 ± 0.039	
32	1.259	max
35	1.377	max
41.2 ±0.1	1.622 ± 0.003	
45	1.771	max
50	1.968	max
67	2.637	max
79 ± 0.5	3.110 ± 0.019	
111 ±1.5	4.370 ± 0.059	
150	5.9	min

Frequency: 'X' band, tunable.

Power output: 60kW, pulsed.

Construction: Packaged, forced-air cooled.

This data should be read in conjunction with GENERAL OPERATIONAL RECOMMENDATIONS - MICROWAVE DEVICES: INTRODUCTION and RADAR AND COMMUNICATION MAGNETRONS which precede this section of the handbook.

CHARACTERISTICS

	Min.	Max.	
Frequency: Tunable over the range	8.5	to 9.6	Gc/s
Pulse voltage ($I_{pulse} = 14A$)	13	15.5	kV
R.F. pulse power output ($I_{pulse} = 14A$)	50	—	kW
Frequency pulling factor (v.s.w.r. = 1.5)	—	18	Mc/s
Frequency temperature coefficient	—	0.25	Mc/s per °C
Input capacitance	—	6.0	pF

CATHODE

Indirectly heated

V_{h_1}	6.3	V
I_{h_1}	1.0	A

Heating time. The cathode must be heated for at least 2 minutes before the application of h.t. The heater voltage must be reduced immediately after the application of h.t. in accordance with the input-power heater-voltage rating chart on page C4.

TYPICAL OPERATION

Frequency	9.0	9.0	9.0	Gc/s
Heater voltage (running)	4.8	0	0	V
Pulse duration	0.1	1.0	3.4	μ s
Pulse repetition frequency	3333	1000	324	p/s
Duty cycle	0.00033	0.001	0.0011	
Pulse current	14	14	14	A
Pulse voltage	13.5	13.5	13.5	kV
Pulse input power	190	190	190	kW
R.F. pulse output power	60	60	60	kW
Mean input current	4.7	14	15.4	mA
Mean input power	63	190	210	W
Mean r.f. output power	20	60	65	W
Frequency pulling (v.s.w.r. = 1.5)	10	10	10	Mc/s

OPERATING NOTES

The valve is provided with four magnetic shunts. (See outline drawings, pages D3 and D4.) From examination of the performance charts the number required for a particular application may be determined. To remove shunts which are not required, grip the tabs firmly with suitable pliers and pull away from the valve.

COOLING

A flow of cooling air must be directed between the radiator fins, and on to cathode and heater seals, in order to keep the temperature below the permitted maximum.

ABSOLUTE MAXIMUM RATINGS

	<i>Min.</i>	<i>Max.</i>	
Pulse current	—	15.5	A
Pulse voltage	—	16.0	kV
Pulse duration	—	3.6	μ s
Duty cycle	—	0.0012	
Mean input power	—	230	W
Voltage pulse rise time			
$0.1\mu\text{s} \leq t_r \leq 1.0\mu\text{s}$	—	0.08	μ s
$t_r = 3.6\mu\text{s}$	—	0.12	μ s
Load mismatch (v.s.w.r.)	—	1.5	
Temperature of anode block	-60	150	$^{\circ}$ C
Pressurisation of waveguide output system	—	{ 43 2200	{ lb/in ² torr
Pressurisation of input system	{ 11 550	—	{ lb/in ² torr

MOUNTING POSITION

Any

MECHANICAL CHARACTERISTICS

	<i>Min.</i>	<i>Max.</i>	
Number of turns of worm shaft to cover the tuning range	—	110	
Tuning torque	10	40	oz/in

PHYSICAL DATA

Weight of magnetron	{ 4.8 2.2	{ lb kg
Weight of magnetron in carton	{ 13.9 6.3	{ lb kg
Dimensions of storage carton	{ 12.5 × 13 × 13 318 × 330 × 330	{ in mm



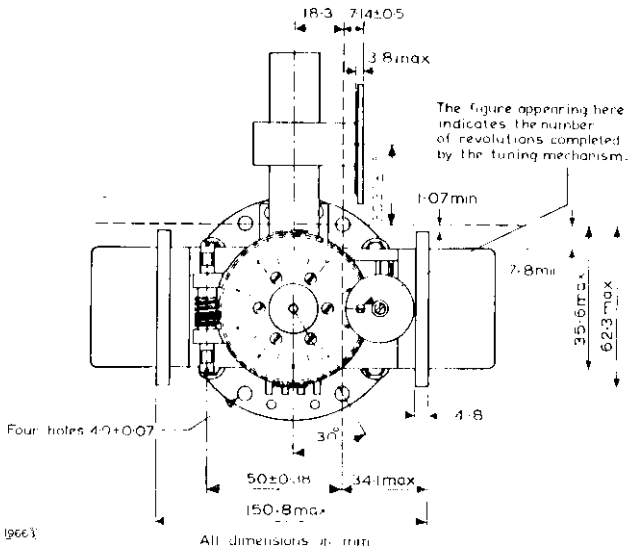
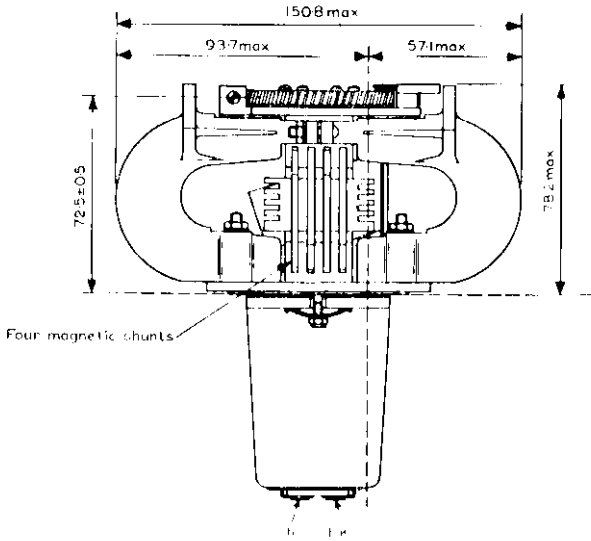

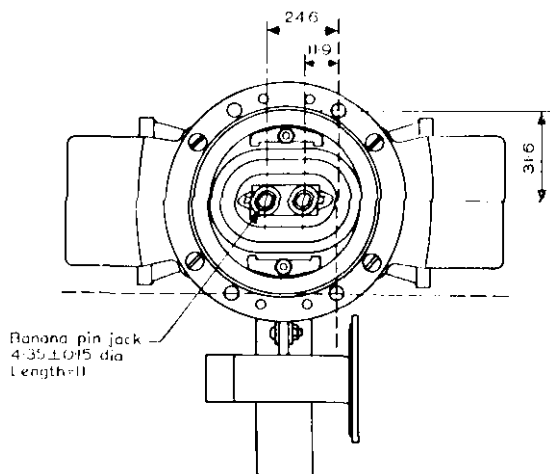
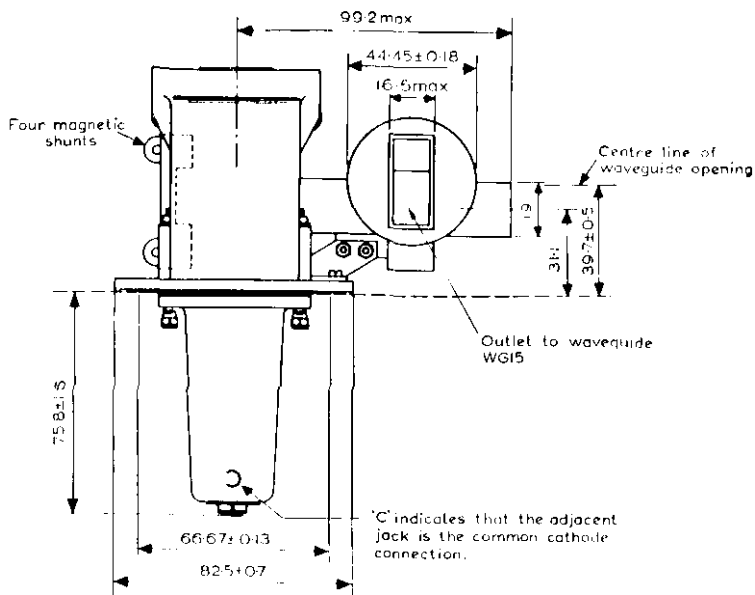

5664

All dimensions in mm

[9608]

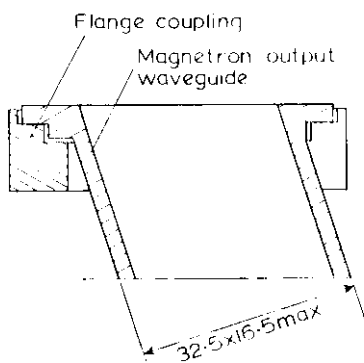
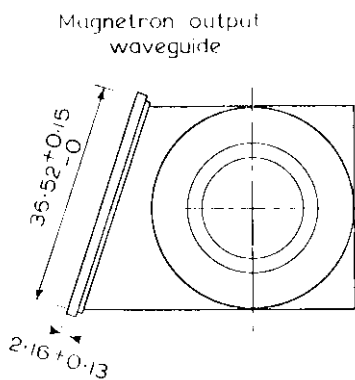
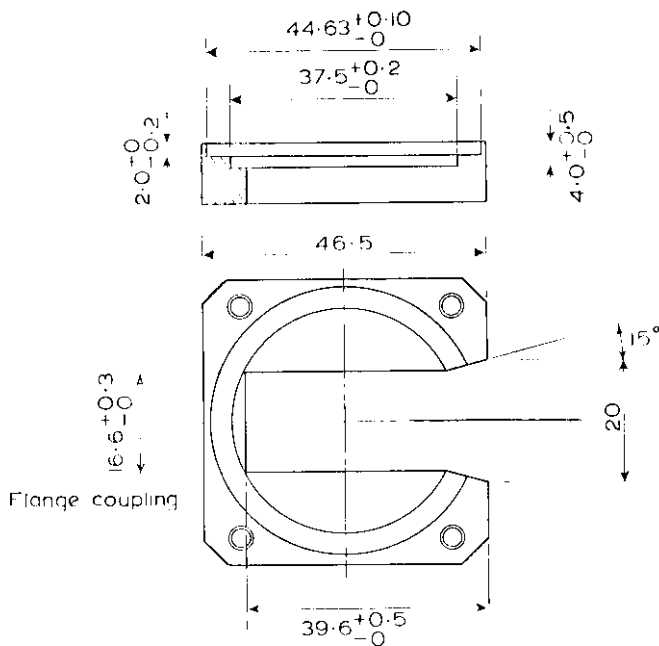

All dimensions in mm

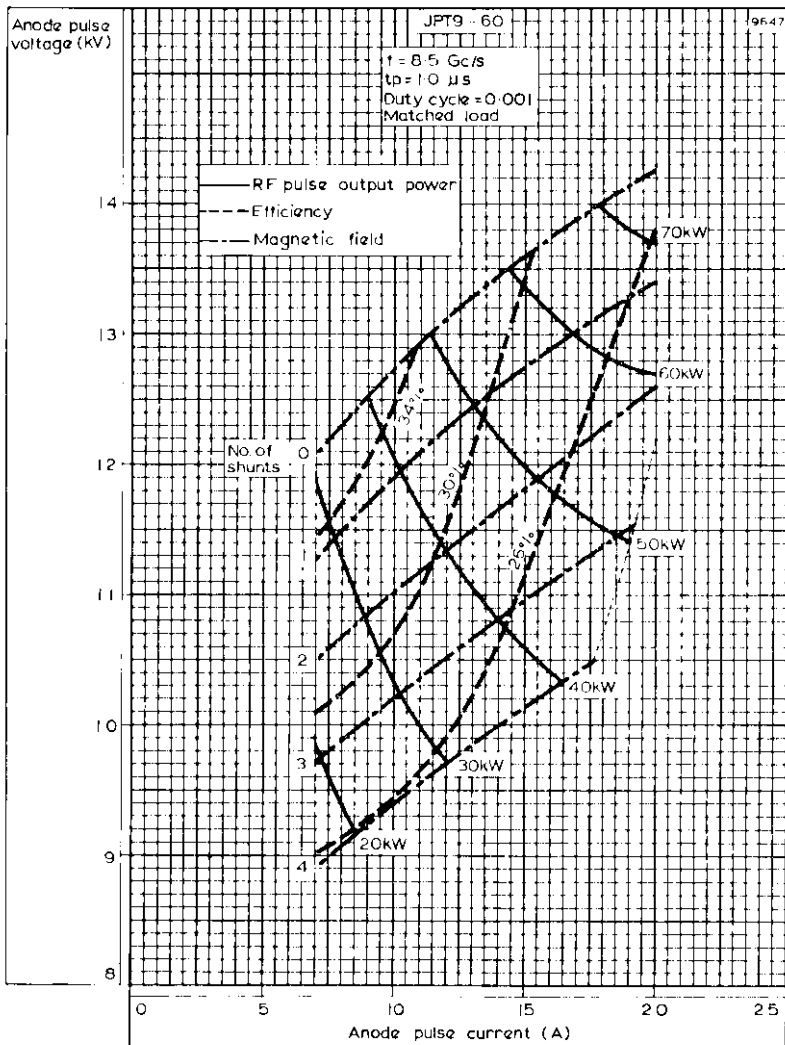

PERFORMANCE CHART ($f = 8.5\text{Gc/s}$)

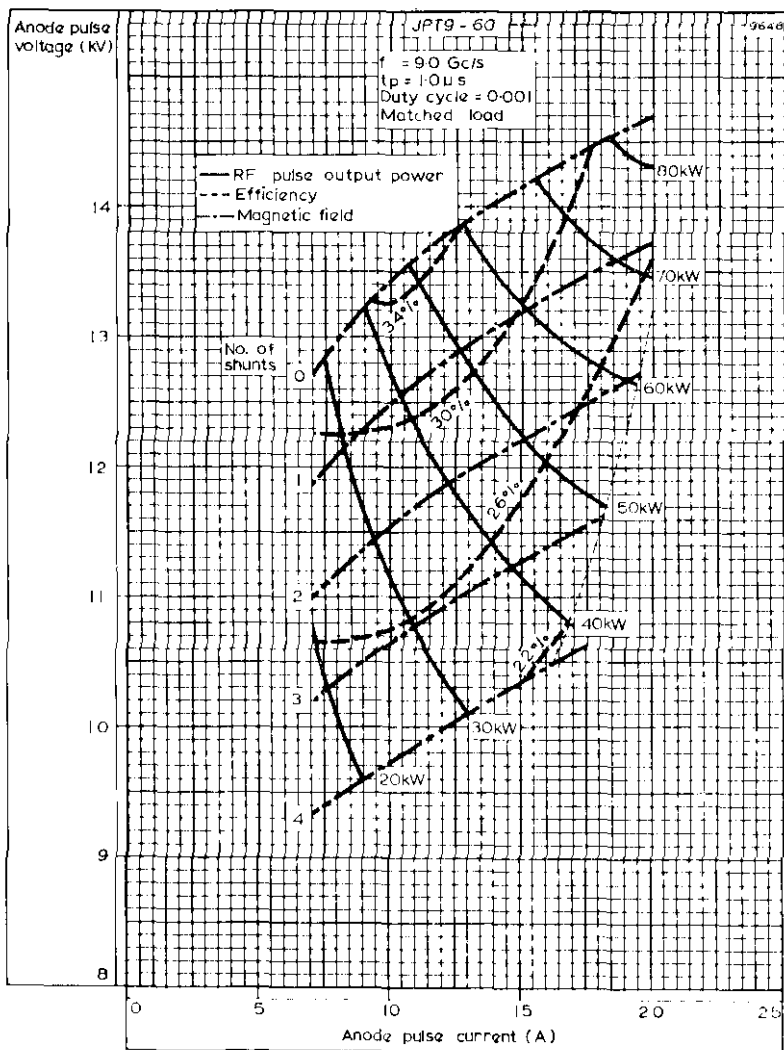

PERFORMANCE CHART ($f = 9.0\text{Gc/s}$)

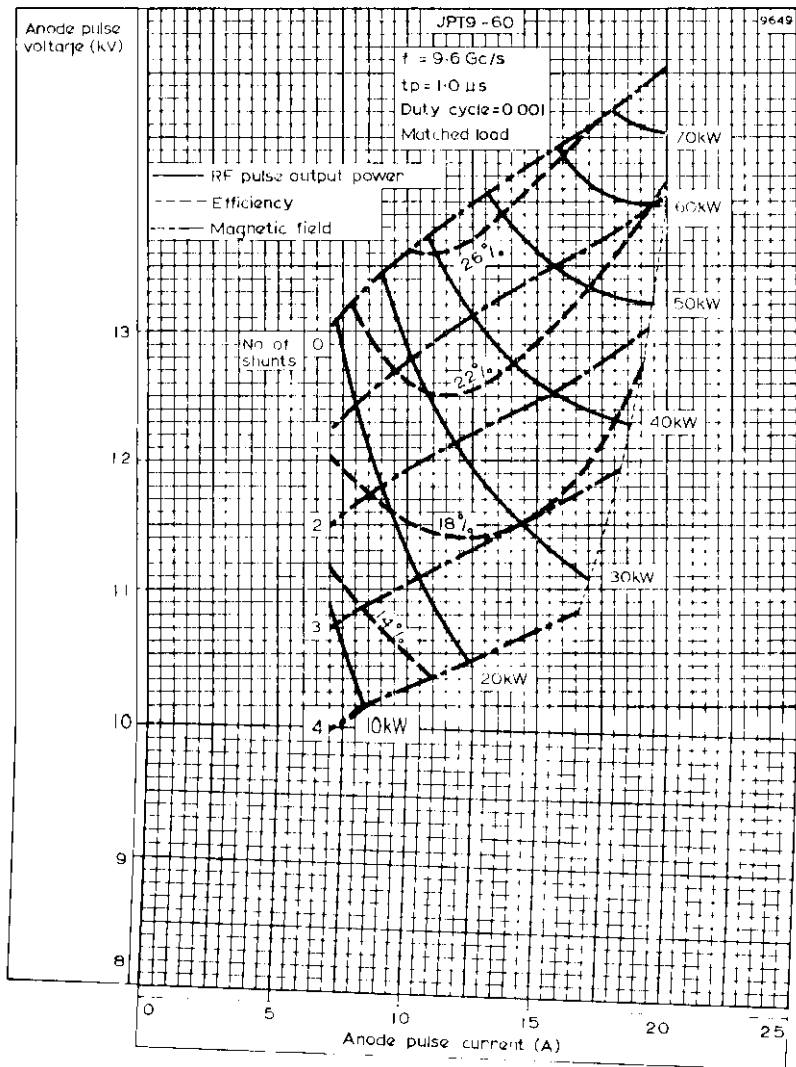
PERFORMANCE CHART ($f = 9.6\text{Gc/s}$)

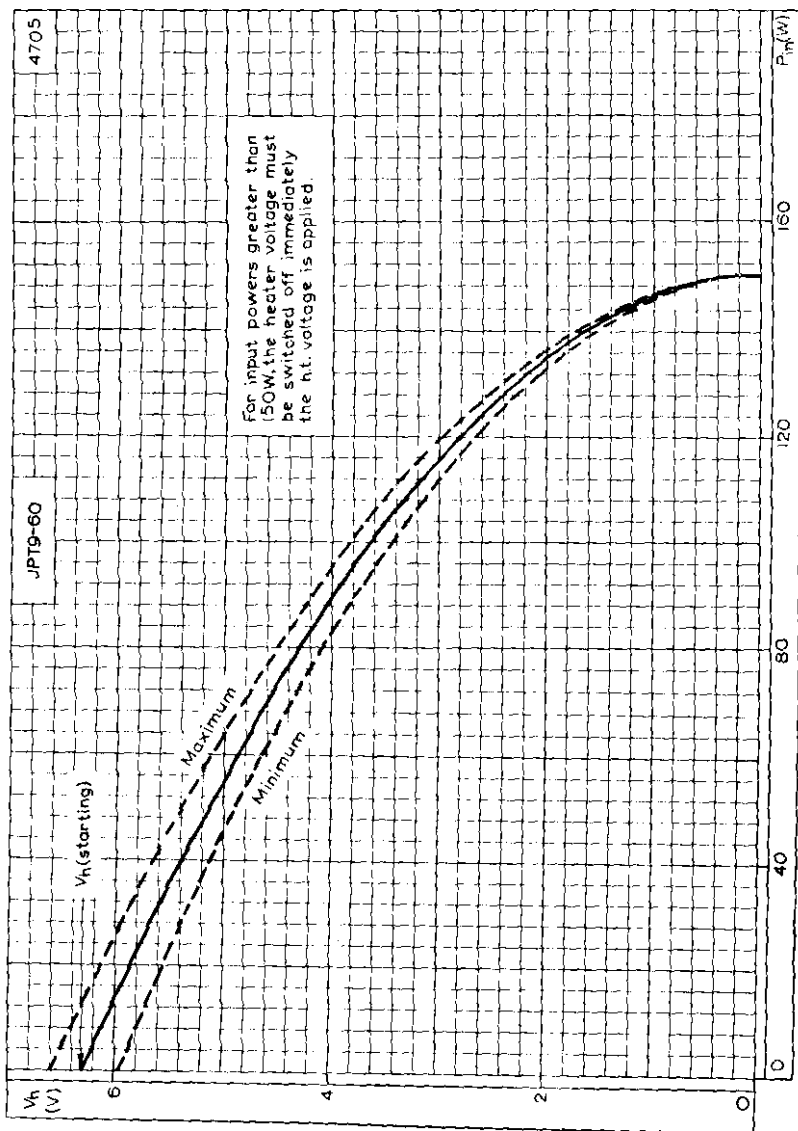

HEATER VOLTAGE PLOTTED AGAINST MEAN INPUT POWER

QUICK REFERENCE DATA

Servo-tunable 'X' band pulsed magnetron, suitable for use in navigational search and fine control radar systems, in either ground based or airborne installations.

Frequency	8.5 to 9.6	GHz
Power output (pulsed)	225	kW
Construction		packaged

To be read in conjunction with
GENERAL OPERATIONAL RECOMMENDATIONS - MICROWAVE DEVICES

OPERATING CONDITIONS

R. F. pulse power output	200	200	225	225	kW
Duty factor	0.00026	0.0007	0.001	0.001	
Pulse duration	0.13	0.34	0.6	1.0	μ s
Pulse repetition frequency	2000	2080	1670	1000	p.p.s.
Heater voltage (running)	9.7	3.0	0	0	V
Pulse current	24	24	27.5	27.5	A
Pulse voltage	21	21	21.5	21.5	kV
Pulse input power	500	500	590	590	kW
Rate of rise of voltage pulse	200	200	200	200	kV/ μ s
Mean input current	6.2	16.8	27.5	27.5	mA
Mean input power	130	350	590	590	W
Mean r.f. output power	52	140	225	225	W
Frequency pulling (v.s.w.r. = 1.5)	11	11	10	10	MHz

CHARACTERISTICS

	Min.	Max.	
Frequency. Tunable over the range	8.5	to 9.6	GHz
Pulse voltage ($I_{\text{pulse}} = 27.5\text{A}$)	20	23	kV
R. F. pulse power output ($I_{\text{pulse}} \approx 27.5\text{A}$)	200	-	kW
Frequency pulling (v. s. w. r. = 1.5)	-	13.5	MHz
Input capacitance	9.0	13	pF

RATINGS (ABSOLUTE MAXIMUM SYSTEM)

	Min.	Max.	
Pulse current	15	30	A
Pulse duration	-	2.75	μs
Duty factor	-	0.0011	
Mean input power	-	630	W
Rate of rise of voltage pulse ($t_p \leq 1.5\mu\text{s}$)	70	225	kV/ μs
($t_p > 1.5\mu\text{s}$)	70	200	kV/ μs
Load mismatch (v. s. w. r.)	-	1.5	

CATHODE

Indirectly heated

V_h	13.75 \pm 10%	V
I_h	3.1 \pm 0.2	A
I_h (surge)max.	12	A
r_h (cold)	0.53	Ω
Minimum warm up time	2.5	min

Heating time. At ambient temperatures above 0°C the cathode must be heated for at least 2.5 minutes before the application of h.t. Below this temperature the heating time must be increased to at least 4 minutes.

For mean input powers greater than 0 watts, it is necessary to reduce the heater voltage immediately after the application of h.t. in accordance with the input power - heater voltage rating chart on page C1.



MOUNTING POSITION

Any

PRESSURISING

See operating notes

PHYSICAL DATA

Weight of magnetron	5.9kg	13lb
---------------------	-------	------

COOLING

Temperatures

Anode block	max.	150	°C
Cathode and heater seals	max.	165	°C

An adequate air flow should be forced through the cooling ducts on the magnetron to keep the anode block temperature below 150°C under any condition of operation. The heater-cathode terminal should also be sufficiently cooled to keep its temperature below 165°C.

OPERATING NOTES

Input pressurization min. 0.82kg/cm² (11.6lb/in²) absolute.

Output pressurization max. 3.2kg/cm² (45lb/in²) absolute

The output assembly must always be pressurized. When the magnetron is not working into a matched load, the pressure on the window must be higher than 1.0kg/cm² (14.2lb/in²) absolute.

TUNING MECHANISM

The frequency of the magnetron decreases with clockwise rotation of the tuner drive shaft, as viewed directly towards the waveguide flange. (See page D4.)

A digital indicator provides a visual indication of the magnetron frequency. A number of frequencies and the corresponding indicator settings are indicated on the wall of the tuner box.

Axial stress on the tuner mechanism should be avoided. The tuner shaft should therefore be driven by a flexible coupling. The torque on the shaft must never exceed 13.8kg cm (1.0ft lb). Adjustment of the tuning mechanism beyond the stated frequency limits must not be attempted. The starting torque required to operate the tuner shaft is max. 1.5kg cm (0.108ft lb). The tuner drive should be capable of supplying 2.3kg cm (0.166ft lb).



OUTLINE DRAWING OF YJ1010

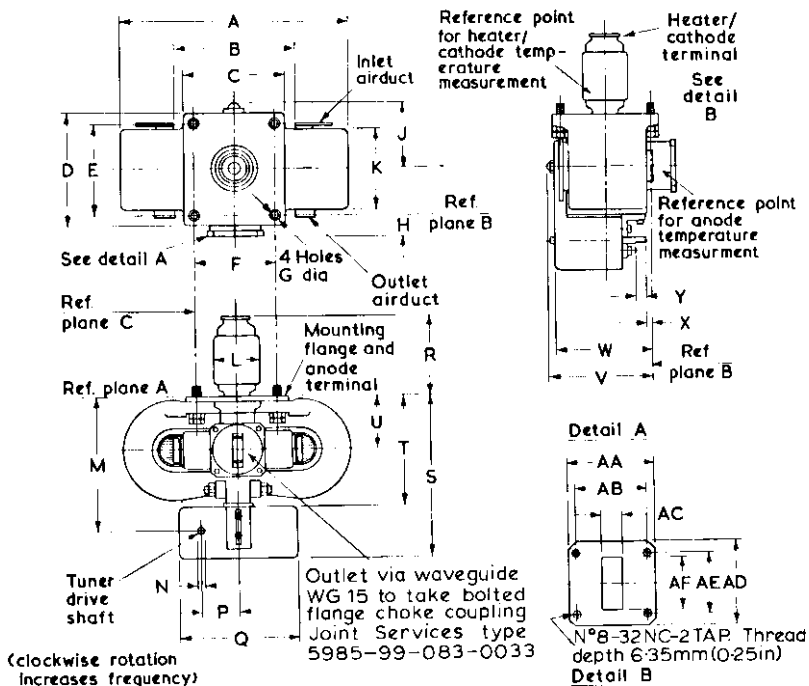

DIMENSIONS

	mm	Inches	
A	195.25	7.687	max.
B	95.94 ± 1.19	3.777 ± 0.047	
C	88.09	3.468	max.
D	98.42	3.875	max.
E	76.20 ± 0.25	3.000 ± 0.010	
F	63.5 ± 0.25	2.500 ± 0.010	
G	7.14 ± 0.12	0.281 ± 0.005	dia.
H	23.01 ± 0.79	0.906 ± 0.031	
J	58.40	2.300	max.
K	73.02	2.875	max.
L	38.10	1.500	max.
M	109.52 ± 2.39	4.312 ± 0.094	
N	4.77 ± 0.025	0.188 ± 0.001	
P	31.75 ± 1.57	1.250 ± 0.062	
Q	101.6	4.000	max.
R	68.5 ± 1.57	2.687 ± 0.062	
S	139.7	5.500	max.
T	86.50	3.406	max.
U	42.06 ± 1.19	1.656 ± 0.047	
V	96.52	3.800	max.
W	83.82	3.300	max.
X	7.92 ± 1.57	0.312 ± 0.062	
Y	15.88 ± 0.79	0.625 ± 0.031	
AA	46.48	1.830	
AB	37.44 ± 0.10	1.474 ± 0.004	
AC	12.62	0.497	
AD	46.48	1.830	
AE	34.34 ± 0.10	1.352 ± 0.004	
AF	28.50	1.122	
AG	13.11	0.516	min.
AH	3.96	0.156	max.
AJ	21.08 ^{+0.20} -0.12	0.830 ^{+0.008} -0.005	
AK	13.72 ^{+0.12} -0.20	0.540 ^{+0.005} -0.008	
AL	6.35 ± 0.38	0.250 ± 0.015	
AM	4.29 ± 0.12	0.169 ± 0.005	
AN	3.17 ± 0.25	0.125 ± 0.010	
AP	19.05	0.750	min.

Millimetre dimensions derived from original inch dimensions

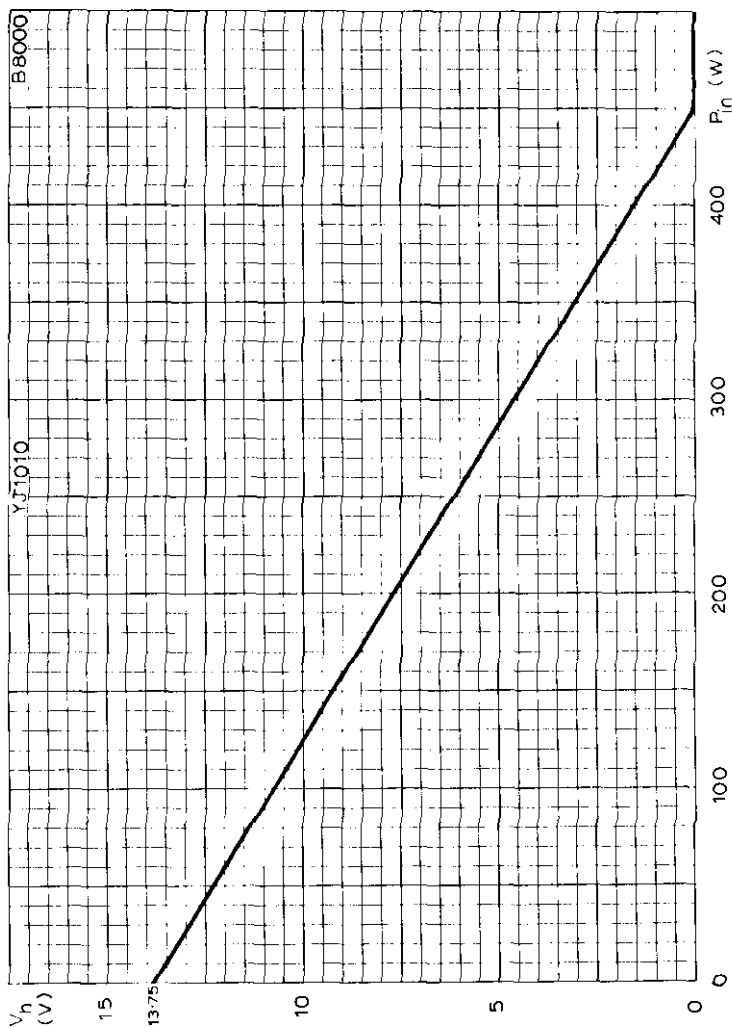

HEATER VOLTAGE PLOTTED AGAINST INPUT POWER

QUICK REFERENCE DATA

Fixed frequency magnetron suitable for use in high-definition short-range radar systems.

Frequency	33	GHz
Power output (pulsed)	30	kW
Construction		Packaged

To be read in conjunction with

GENERAL OPERATIONAL RECOMMENDATIONS - MICROWAVE DEVICES

OPERATING CONDITIONS

R. F. pulse power output	25	30	30	kW
Duty factor	0.0001	0.0002	0.0002	
Pulse duration	0.04	0.1	0.3	μ s
Pulse repetition frequency	2500	2000	670	pulse/s
Heater voltage (running)	4.0	3.8	3.8	V
Pulse current	10.5	12.5	12.5	A
Pulse voltage	12.5	12.5	12.5	kV
Pulse input power	131	156	156	kW
Rate of rise of voltage pulse	300	250	250	kV/ μ s
Mean input current	1.6	2.5	2.5	mA
Mean input power	20	31.3	31.3	W
Mean r.f. output power	2.5	6.0	6.0	W
Frequency pulling (v.s.w.r. - 1.5)	40	40	40	MHz

CATHODE

Indirectly heated

V_h	3.8 to 4.4	V
I_h (at $V_h = 4.0V$)	2.7 to 4.1	A
I_h (surge) max.	8.0	A
r_h (cold) min.	0.16	Ω
t_{h-k} min.	180	s

For mean input powers greater than 22 watts, it is necessary to reduce the heater voltage immediately after application of h.t. in accordance with the input power-heater voltage rating chart on page 3.



CHARACTERISTICS

	Min.	Max.	
Frequency (fixed within the band)	32.7	33.4	GHz
Pulse voltage ($I_{\text{pulse}} = 12.5\text{A}$)	11.5	13.5	kV
R.F. pulse power output ($I_{\text{pulse}} = 12.5\text{A}$)	27.5	-	kW
Frequency pulling (v. s. w. r. = 1.5)	-	50	MHz
Frequency temperature coefficient	-	1.0	MHz/deg C
Distance of v. s. w. minimum from face of mounting plate into valve	0.58	3.15	mm
Frequency pushing	-	4.0	MHz/A

RATINGS (ABSOLUTE MAXIMUM SYSTEM)

	Min.	Max.	
Pulse current	0.0	16	A
Pulse duration	-	0.5	μs
Duty factor	-	0.0003	
Mean input power	-	60	W
Rate of rise of voltage pulse $< 0.1\mu\text{s}$	200	400	kV/ μs
Rate of rise of voltage pulse $\geq 0.1\mu\text{s}$	-	300	kV/ μs
Load mismatch (v. s. w. r.)	-	1.5	

MOUNTING POSITION

Any

PRESSURISING

To prevent arcing the pressure must exceed 450 torr.

PHYSICAL DATA

	kg	lb
Weight of magnetron	1.9	4.2
Weight of magnetron in carton	5.8	12.8
	mm	in
Dimensions of storage carton	178 x 244 x 285	7.0 x 9.6 x 11.2

COOLING

For normal operating conditions no additional cooling of the magnetron will be required to keep the temperature of the anode block and heater seals below the stated maximum ratings.

Temperatures

Anode block max. (between 2nd and 3rd fins)	150	$^{\circ}\text{C}$
Cathode and heater seals max.	150	$^{\circ}\text{C}$

ACCESSORY

Cathode connector

55356



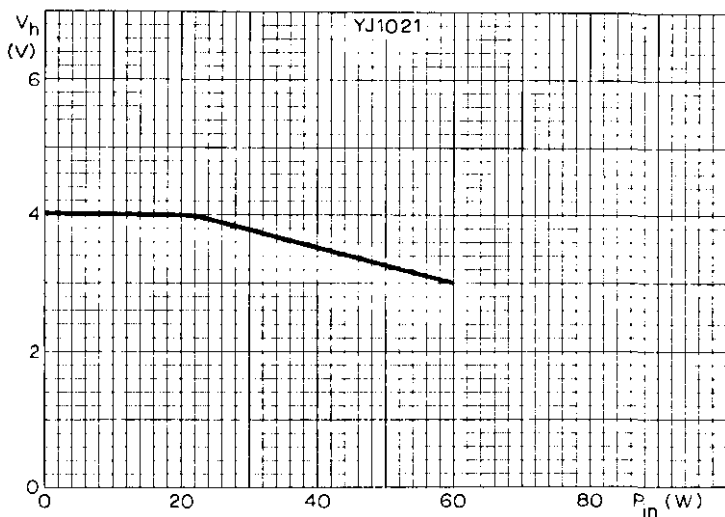

HEATER VOLTAGE PLOTTED AGAINST MEAN INPUT POWER
MEAN INPUT POWER = MEAN INPUT CURRENT \times 12 500 \times DUTY FACTOR

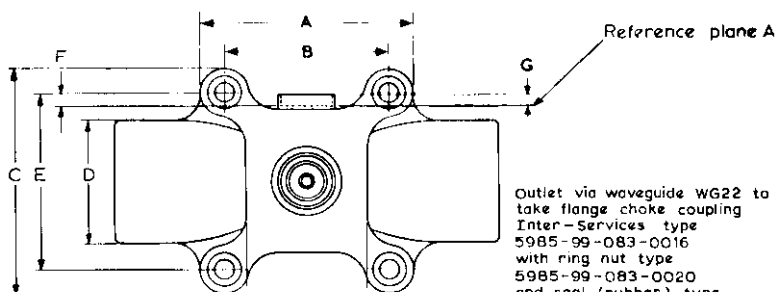

Outlet via waveguide WG22 to take flange choke coupling
 Inter-Services type
 5985-99-083-0016
 with ring nut type
 5985-99-083-0020
 and seal (rubber) type
 5985-99-083-0021.
 Locating ring type
 5985-99-083-0017
 and plain flange type
 5985-99-083-0019
 form an integral part of the magnetron

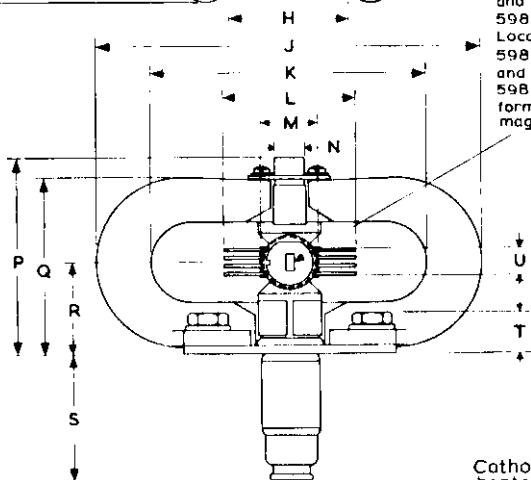

4 holes, 6mm metric thread

Cathode heater
 Heater

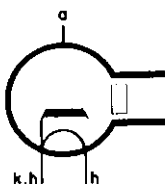
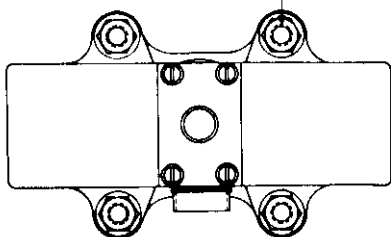
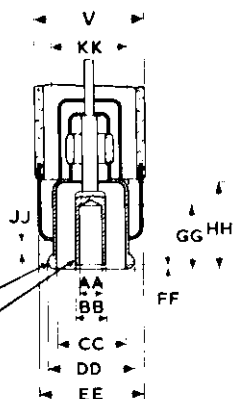

DIMENSIONS

	Millimetres	Inches	
A	87.3	3.437	max.
B	64.29 ± 0.25	2.531 ± 0.010	
C	92	3.622	max.
D	49.2	1.937	max.
E	70.64 ± 0.25	2.781 ± 0.010	
F	5.5 ± 1.0	0.217 ± 0.039	
G	4.8	0.189	max.
H	47.6	1.874	min.
J	150.7	5.933	max.
K	97	3.819	min.
L	53	2.087	max.
M	23	0.906	max.
N	13	0.512	max.
P	81	3.189	max.
Q	72.2	2.842	max.
R	35.6 ± 1.0	1.402 ± 0.039	
S	50	1.968	max.
T	16.5 ± 1.5	0.650 ± 0.059	
U	11	0.433	max.
V	23	0.906	max.
AA	4.30 ± 0.15	0.169 ± 0.006	
BB	6.0 ± 0.1	0.236 ± 0.004	
CC	13.3 ± 0.2	0.524 ± 0.008	
DD	16.9 ± 0.2	0.665 ± 0.008	
EE	20.5	0.807	max.
FF	0.55 ± 0.45	0.022 ± 0.018	
GG	12.5	0.492	min.
HH	15	0.591	min.
JJ	2.0	0.079	min.
KK	15.0 ± 0.2	0.591 ± 0.008	

Inch dimensions derived from original millimetre dimensions.

QUICK REFERENCE DATA

Rugged magnetron with low frequency temperature coefficient, suitable for high altitude operation.

Frequency (Mechanically tunable)	5.65 Gc/s
Power output (pulsed)	120 W
Construction	Packaged, coaxial output

To be read in conjunction with GENERAL OPERATIONAL RECOMMENDATIONS - MICROWAVE DEVICES.

CHARACTERISTICS

	Min.	Max.	
Frequency			
Tunable over the range	5.4	5.9	Gc/s
Pulse voltage (1 pulse = 0.8 A)	1.00	1.35	kV
R. F. pulse power output (1 pulse = 0.8 A)	70	-	W
Frequency pulling (v. s. w. r. = 1.5)	-	12	Mc/s
Frequency temperature coefficient	-	-0.1	Mc/s per °C
Frequency modulation under vibration of 12g (50-2000c/s)	-	2.0	Mc/s
Input capacitance	-	6.0	pF
Frequency pushing	-	15	Mc/s per A

TYPICAL OPERATION

R. F. pulse power output	160	W
Duty factor	0.002	
Pulse duration	1.0	μs
Pulse repetition frequency	2000	p. p. s.
Heater voltage (running)	5.0	V
Pulse current	0.8	A
Pulse voltage	1.2	kV
Pulse input power	944	W
Rate of rise of voltage pulse	6.0	kV/μs
Mean input current	1.6	mA
Mean input power	1.9	W
Mean r. f. output power	320	mW
Frequency pulling (v. s. w. r. = 1.5)	10	Mc/s



CATHODE

Indirectly heated

Vh	5.0	V
Ih	0.5	A

Heating time. At ambient temperatures above 0 °C the cathode must be heated for at least 0.5 minutes before the application of h.t.

ABSOLUTE MAXIMUM RATINGS

	Min.	Max.	
Pulse current	0.6	1.0	A
Pulse duration	-	3.0	μs
Duty factor	-	0.002	
Mean input power	-	2.5	W
Rate of rise of voltage pulse	-	8.0	kV/μs
Load mismatch (v. s. w. r.)	-	1.5	
Temperature of anode block	-	100	°C

MOUNTING POSITION

Any

PHYSICAL DATA

	lb	kg
Weight of magnetron	0,45	0,2
Weight of magnetron in carton	9,0	4,1
	in	cm
Dimensions of storage carton	12,5 x 11,5 x 11,0	318 x 292 x 279

COOLING

In normal circumstances natural cooling is adequate but where the ambient temperature is abnormally high, or where convection cooling is restricted, provision for conduction cooling may be made by a clamp, of non-magnetic material, around the body.

OUTPUT CONNECTION

Output via 50 Ω T.N.C. Male Connector

DIMENSIONS

	Inches	Millimetres
A	4.006 ± 0.069	101.75 ± 1.75
B	1.270 ± 0.010	32.25 ± 0.25
C	1.348 ± 0.010	34.25 ± 0.25
D	1.742 ± 0.030	44.25 ± 0.75
E	1.545 ± 0.030	39.25 ± 0.75
G	0.709 ± 0.008	18.0 ± 0.2
H	0.640	16.25 max.
J	0.876 ± 0.010	22.25 ± 0.25
K	0.502 ± 0.010	12.75 ± 0.25
L	0.177 ± 0.004	4.5 ± 0.1
M	0.295 ± 0.020	7.5 ± 0.5
N	0.394 ± 0.010	10.00 ± 0.25
S	0.167 ± 0.010	4.25 ± 0.25
T	1.06	27.0
U	8.0	203 min.
V	0.192 ± 0.001	4.875 ± 0.025
W	1.024 ± 0.016	26.0 ± 0.4
Y	0.077 ± 0.022	1.95 ± 0.55

Inch dimensions derived from original millimetre dimensions.

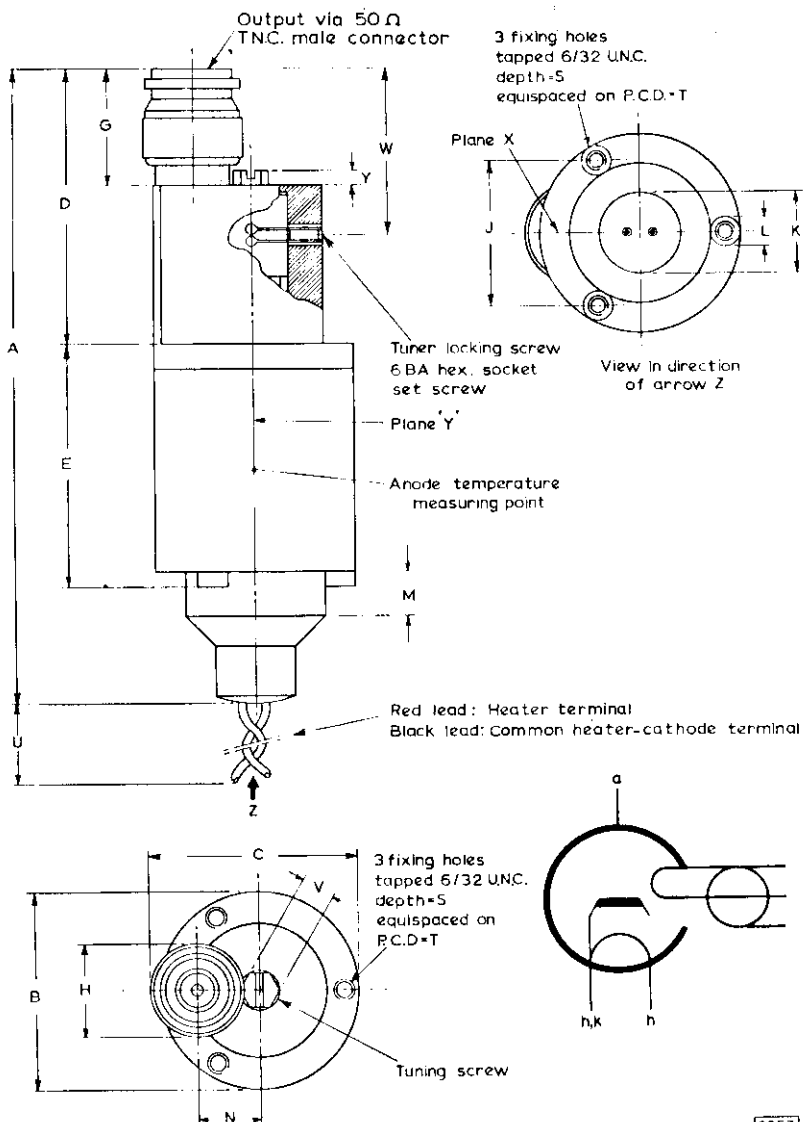

9957

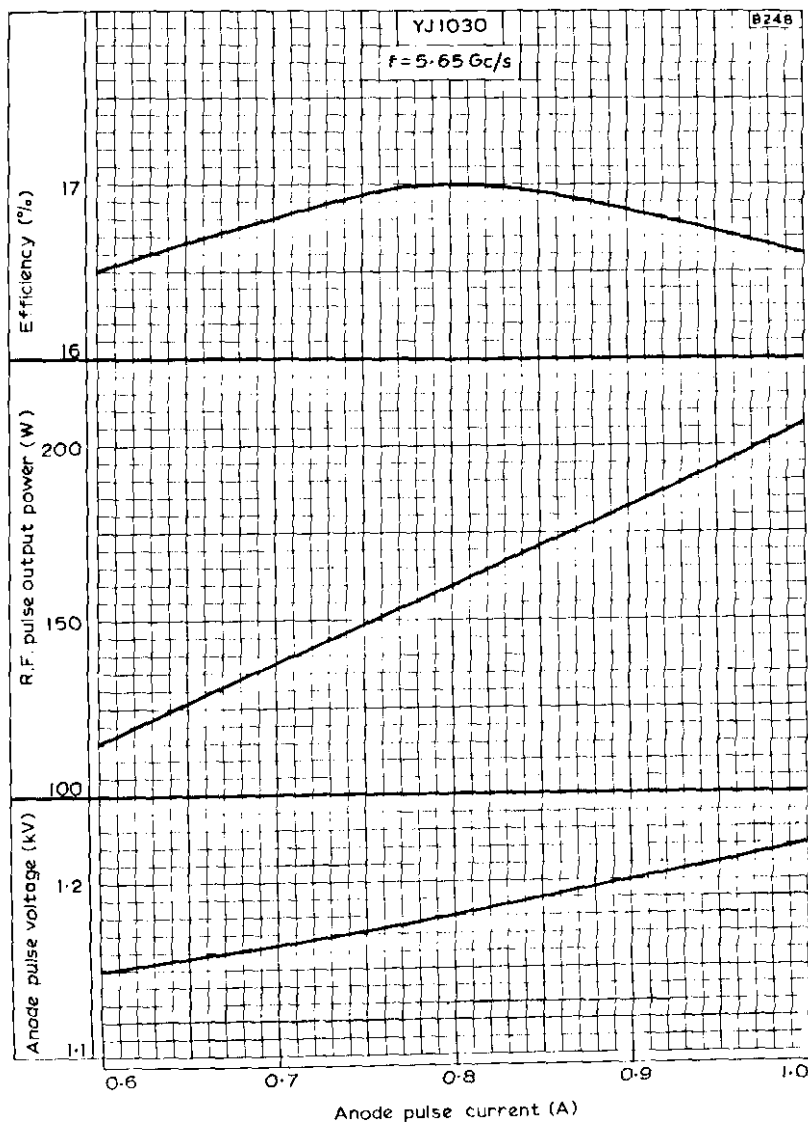

ANODE PULSE VOLTAGE, R. F. PULSE OUTPUT POWER AND EFFICIENCY
 PLOTTED AGAINST ANODE PULSE CURRENT

TENTATIVE DATA

QUICK REFERENCE DATA

Fixed frequency 'X' band pulsed magnetron.
Suitable for high altitude operation.

Frequency	9,375	Gc/s
Power output (pulsed)	14	kW

To be read in conjunction with
GENERAL OPERATIONAL RECOMMENDATIONS - MICROWAVE DEVICES

CHARACTERISTICS

	Min.	Max.	
Frequency			
Fixed within the band	9,345	9,405	Gc/s
Pulse voltage ($I_{\text{pulse}} = 5.75\text{A}$)	5.9	6.3	kV
R. F. pulse power output ($I_{\text{pulse}} = 5.75\text{A}$)	12.5	-	kW
Frequency pulling (v. s. w. r. = 1, 2)	-	15	Mc/s
Frequency temperature coefficient	-	-0.25	Mc/s per deg C
Input capacitance	-	8.0	pF

TYPICAL OPERATION

R. F. pulse power output	14	kW
Duty factor	0.001	
Pulse duration	2.5	μs
Pulse repetition frequency	400	p. p. s.
Heater voltage (running)	6.3	V
Pulse current	5.75	A
Pulse voltage	6.1	kV
Pulse input power	35	kW
Rate of rise of voltage pulse	70	kV/ μs
Mean input current	5.75	mA
Mean input power	5.6	W
Mean R. F. output power	2.24	W
Frequency pulling (v. s. w. r. = 1, 2)	12	Mc/s

CATHODE

Indirectly heated

V_h	6.3	V
I_h	0.5 to 0.6	A
f_h	400	c/s

Heating time. At ambient temperatures above 0°C the cathode must be heated for at least 1.5 minutes before the application of h.t. Below this temperature the heating time must be increased to at least 2.0 minutes.

ABSOLUTE MAXIMUM RATINGS

	Min.	Max.	
Pulse current	5.0	6.5	A
Pulse duration	-	2.5	μs
Duty factor		0.0015	
Mean input power		60	W
Rate of rise of voltage pulse		80	$\text{kV}/\mu\text{s}$
Load mismatch (v. s. w. r.)		1.2	
Temperature of anode block		120	$^{\circ}\text{C}$

END OF LIFE PERFORMANCE

The valve is deemed to have reached end of life when it fails to satisfy the following: -

R. F. pulse power output ($I_{\text{pulse}} = 5.75\text{A}$)

	10	kW
--	----	----

	Min.	Max.	
Frequency			
Within the band	9.345	9.405	Gc/s
Pulse voltage ($I_{\text{pulse}} = 5.75\text{A}$)	5.9	6.5	kV

MOUNTING POSITION

Any

PRESSURISING

The valve is fitted with flying leads and the output waveguide is sealed with a vacuum tight window to allow operation at high altitude without pressurising. Operation to 60 000 ft can be achieved. The output window must not be pressurised.

PHYSICAL DATA

	lb	kg
Weight of magnetron	3.75	1.7

COOLING

In normal circumstances natural cooling is adequate but where the ambient temperature is abnormally high, or convection cooling is restricted, artificial cooling may be necessary to keep the block temperature below the permitted maximum.

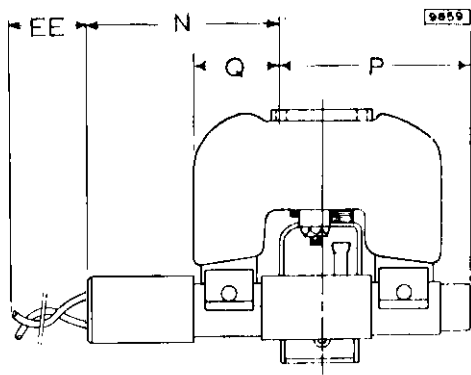

DIMENSIONS

	Inches	Millimetres	
N	3.19	81	max.
P	2.10	55.6	max.
Q	1.19	30.2	max.
EE	6.0	152	min.

Inch dimensions derived from original millimetre dimensions,
except dimension "EE".

OUTLET VIA WAVEGUIDE WG16
TO TAKE BOLTED FLANGE CHOKE
COUPLING JOINT-SERVICES TYPE 5985-99-0830051

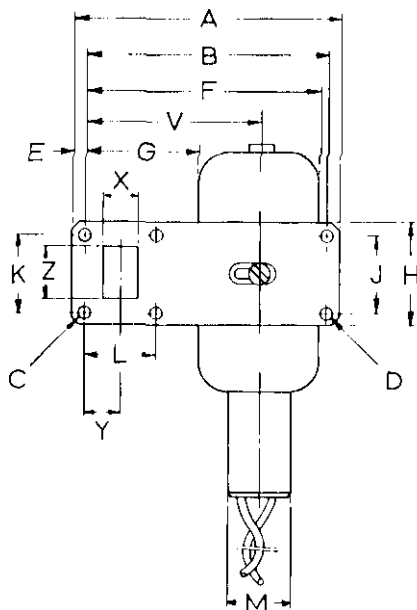
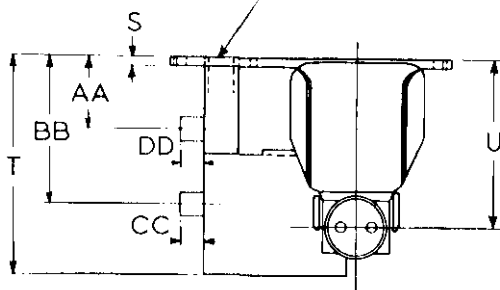

B3741

DIMENSIONS

	Inches	Millimetres	
A	4.47	113.5	
B	4.10 ± 0.004	104.2 ± 0.10	
C	0.17 ± 0.003	4.32 ± 0.08	
D	0.175 ± 0.003	4.45 ± 0.08	
E	0.19	4.8	max.
F	4.0	102	max.
G	1.9	49	min.
H	1.64	41.7	max.
J	1.219 ± 0.003	30.99 ± 0.08	
K	1.219 ± 0.004	30.99 ± 0.10	
L	1.269 ± 0.004	32.51 ± 0.10	
M	1.00	25.4	max.
R	0.25	6.4	max.
S	0.125 ± 0.010	3.18 ± 0.25	
T	3.23	82.6	max.
U	2.4 ± 0.12	64 ± 3.0	
V	3.0 ± 0.12	76 ± 3.0	
X	0.457 ± 0.003	10.16 ± 0.08	
Y	0.640 ± 0.004	16.25 ± 0.10	
Z	0.910 ± 0.004	22.68 ± 0.10	
AA	0.9 ± 0.12	22 ± 3.0	
BB	1.8 ± 0.20	45 ± 5.0	
CC	0.4	10	max.
DD	0.36	9.5	max.

Inch dimensions derived from
original millimetre dimensions

QUICK REFERENCE DATA

Fixed frequency 'X' band pulsed magnetron. Suitable for high altitude operation.

Frequency	9.24	GHz
Power output (pulsed)	22	kW
Construction	Packaged, flying leads	

To be read in conjunction with

GENERAL OPERATIONAL RECOMMENDATIONS - MICROWAVE DEVICES

OPERATING CONDITIONS

R. F. pulse power output	22	kW
Duty factor	0.0004	
Pulse duration	0.5	μ s
Pulse repetition frequency	800	p.p.s.
Heater voltage (running)	6.3	V
Pulse current	7.5	A
Pulse voltage	7.5	kV
Pulse input power	56.25	kW
Rate of rise of voltage pulse	60	kV/ μ s
Mean input current	3.0	mA
Mean input power	22.5	W
Mean r.f. output power	8.8	W
Frequency pulling (v.s.w.r. = 1.2)	12	MHz

CATHODE

Indirectly heated

V_h	6.3	V
I_h	550	mA
Frequency of heater supply	400	Hz

Heating time. At ambient temperatures above 0°C the cathode must be heated for at least 45 seconds before the application of h.t. Below this temperature the heating time must be increased to at least 1.0 minute.

CHARACTERISTICS

	Min.		Max.	
Frequency fixed within the band	9.21	to	9.27	GHz
Pulse voltage ($I_{\text{pulse}} = 7.5\text{A}$)	7.0		7.7	kV
R.F. pulse power output ($I_{\text{pulse}} = 7.5\text{A}$)	20		-	kW
Frequency pulling (v.s.w.r. = 1.2)	-		15	MHz
Frequency temperature coefficient	-		-0.25	MHz per degC
Frequency pushing	-		1.5	MHz per A

RATINGS (ABSOLUTE MAXIMUM SYSTEM)

	Min.		Max.	
Pulse current	6.0		9.0	A
Pulse duration	-		1.0	μs
<i>Duty factor</i>	-		0.0015	
Mean input power	-		85	W
Rate of rise of voltage pulse	-		100	kV/ μs
Load mismatch (v.s.w.r.)	-		1.5	

END OF LIFE PERFORMANCE

The valve is deemed to have reached end of life when it fails to satisfy the following:-

R.F. pulse power output ($I_{\text{pulse}} = 7.5\text{A}$)			16	kW
	Min.		Max.	
Frequency fixed within the band	9.21	to	9.27	GHz
Pulse voltage ($I_{\text{pulse}} = 7.5\text{A}$)	7.0	to	7.9	kV

MOUNTING POSITION

Any

PRESSURISING

To meet the reduced atmospheric pressure during high altitude operation the output waveguide is sealed with a vacuum tight window. Operation up to 60 000ft is offered provided a choke coupling is used but on no account is pressurisation of the output window permitted. A protective cover for the window is supplied.



PHYSICAL DATA

Weight of magnetron	1.2	kg
Weight of magnetron in carton	2.3	kg
Dimensions of storage carton	19.7 × 20.3 × 24.8 cm	

COOLING

In normal circumstances natural cooling is adequate, but where the ambient temperature is abnormally high, or convection cooling is restricted, artificial cooling may be necessary to keep the block temperature below the permitted maximum.

Temperature

Anode block max.	120	°C
------------------	-----	----

OUTLINE DRAWING OF YJ1050

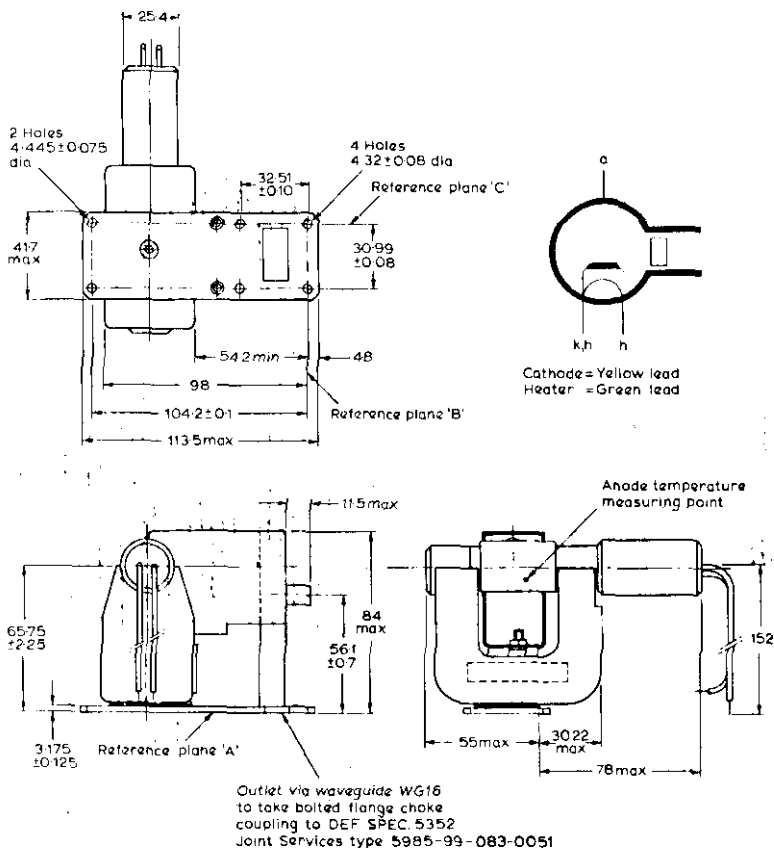

All dimensions in mm

65951

DIMENSIONS

Millimetres	Inches	Millimetres	Inches	
152	5.98	41.7	1.641	max.
113.5	4.468	32.51 ± 0.10	1.280 ± 0.004	
104.2 ± 0.1	4.102 ± 0.004	30.99 ± 0.08	1.220 ± 0.003	
98	3.86	30.22	1.189	max.
84	3.30	25.4	1.000	
78	3.07	11.5	0.452	max.
65.75 ± 2.25	2.588 ± 0.088	4.8	0.189	
56.1 ± 0.7	2.209 ± 0.027	4.445 ± 0.075	0.175 ± 0.003	dia.
55	2.16	4.32 ± 0.08	0.170 ± 0.003	dia.
54.2	2.134	3.175 ± 0.125	0.125 ± 0.005	

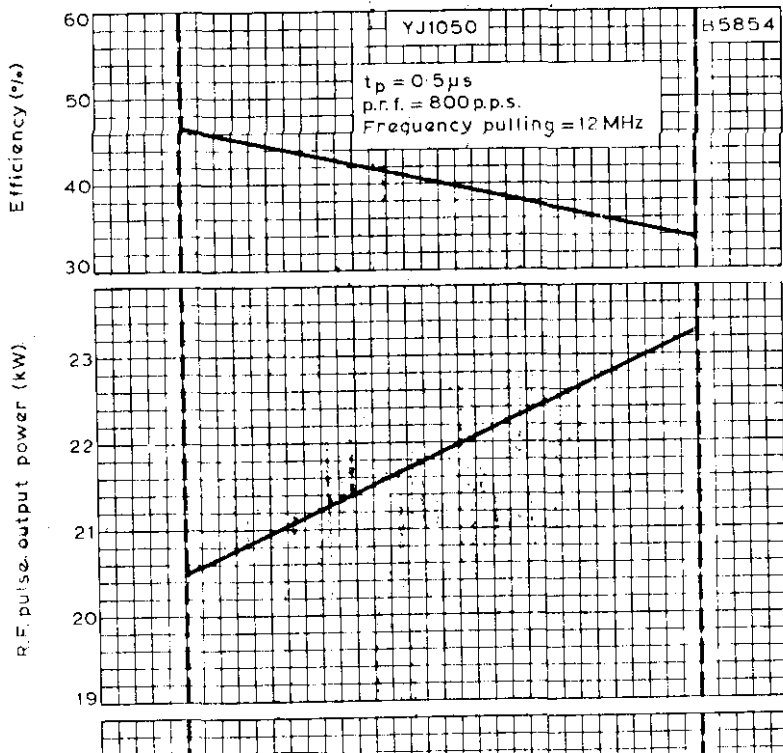

PRELIMINARY DATA

QUICK REFERENCE DATA

Fixed frequency 'X' band pulsed magnetron. Suitable for high altitude operation.

Frequency	9.375	Gc/s
Power output (pulsed)	20	kW

To be read in conjunction with GENERAL OPERATIONAL RECOMMENDATIONS - MICROWAVE DEVICES.

CHARACTERISTICS

	Min.	Max.	
Frequency			
Fixed within the band	9.345	9.405	Gc/s
Pulse voltage (1 pulse = 7.5 A)	6.4	7.4	kV
R. F. pulse power output (1 pulse = 7.5 A)	18	-	kW
Frequency pulling (v. s. w. r. = 1.5)	-	15	Mc/s
Frequency temperature coefficient	-	-0.25	Mc/s per °C
Input capacitance	-	8.0	pF

TYPICAL OPERATION

R. F. pulse power output	20	20	kW
Duty factor	0.0007	0.001	
Pulse duration	1.8	2.5	μs
Pulse repetition frequency	400	400	p. p. s.
Heater voltage (running)	5.4	4.6	V
Pulse current	7.5	7.5	A
Pulse voltage	7.2	7.2	kV
Pulse input power	54	54	kW
Rate of rise of voltage pulse	50	50	kV/μs
Mean input current	5.3	7.5	mA
Mean input power	38	54	W
Mean r. f. output power	14	20	W
Frequency pulling (v. s. w. r. = 1.5)	14	14	Mc/s

CATHODE

Indirectly heated

Vh	6.3	V
Ih	0.55	A

Heating time. At ambient temperatures above 0°C the cathode must be heated for at least 2 minutes before the application of h.t. Below this temperature the heating time must be increased to at least 3 minutes.

For mean input powers greater than 25 watts, it is necessary to reduce the heater voltage immediately after the application of h.t. in accordance with the input power-heater voltage rating chart on page C1.

ABSOLUTE MAXIMUM RATINGS

	Min.	Max.	
Pulse current	5.0	8.0	A
Pulse duration	-	2.5	μs
Duty factor	-	0.002	
Mean input power	-	80	W
Rate of rise of voltage pulse	-	60	$\text{kV}/\mu\text{s}$
Load mismatch (v. s. w. r.)	-	1.5	
Temperature of anode block	-	120	$^{\circ}\text{C}$

MOUNTING POSITION

Any

PRESSURISING

The valve is fitted with flying leads and the output waveguide is sealed with a vacuum tight window to allow operation at high altitude without pressurising. Operation to 60,000 ft can be achieved.

PHYSICAL DATA

	lb	kg
Weight of magnetron	3.25	1.5
Weight of magnetron in carton	5.5	2.5

	in	mm
Dimensions of storage carton	7.75 x 8.0 x 9.75	197 x 203 x 248

COOLING

In normal circumstances natural cooling is adequate, but where the ambient temperature is abnormally high, or convection cooling is restricted artificial cooling may be necessary to keep the block temperature below the permitted maximum

DIMENSIONS

	Inches	Millimetres	
A	4.47	113.5	max
B	4.103 ± 0.004	104.2 ± 0.1	
C	0.17 ± 0.003	4.32 ± 0.08	
D	0.175 ± 0.003	4.45 ± 0.08	
E	0.19	4.8	max
F	4.0	102	max
G	1.93	49	min
H	1.64	41.7	max
J	1.22 ± 0.003	30.99 ± 0.08	
K	1.22 ± 0.004	30.99 ± 0.1	
L	1.28 ± 0.004	32.51 ± 0.1	
M	1.0	25.4	max.
S	0.125 ± 0.01	3.18 ± 0.25	
T	3.25	82.6	max
U	2.52 ± 0.118	64 ± 3	
V	3.0 ± 0.118	76 ± 3	
X	0.400 ± 0.003	10.16 ± 0.08	
Y	0.640 ± 0.004	16.25 ± 0.10	
Z	0.900 ± 0.004	22.86 ± 0.10	
AA	0.88 ± 0.118	22 ± 3	
BB	1.8 ± 0.197	53 ± 5	
CC	0.39	10	max
DD	0.38	9.5	max

Inch dimensions are derived from the original millimetre dimensions

OUTLET VIA WAVEGUIDE WG16
TO TAKE BOLTED FLANGE CHOKE
COUPLING JOINT SERVICES TYPE 5985-99-0830051

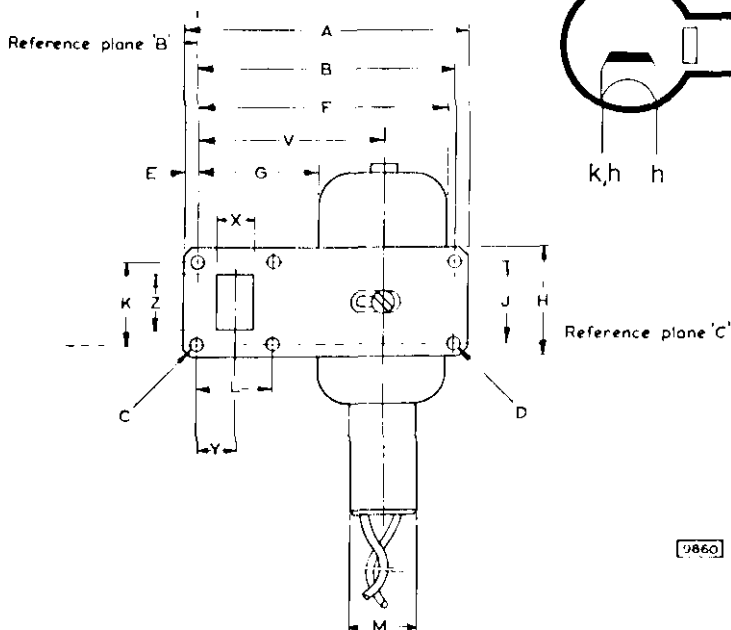
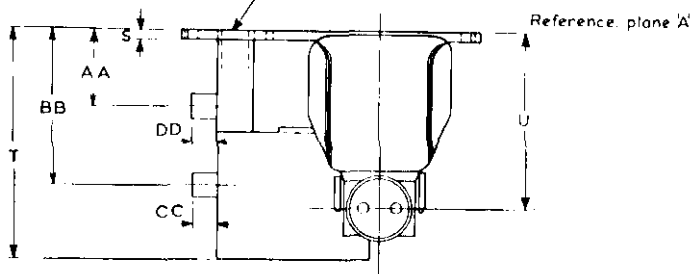

ANODE CONNECTION TERMINATED AT THE BASE PLATE

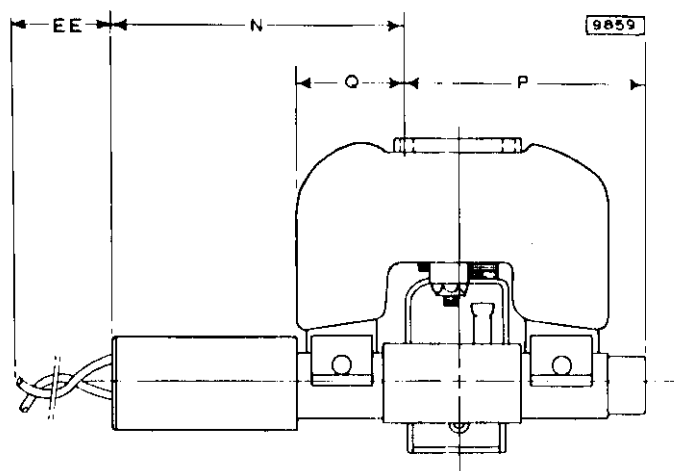

COMMON HEATER/CATHODE LEAD IDENTIFIED BY A SLEEVE

DIMENSIONS

	Inches	Millimetres	
N	3.19	81	max
P	2.19	55.6	max
Q	1.19	30.2	max
EE	6.0	152	

Inch dimensions are derived from the original millimetre dimensions

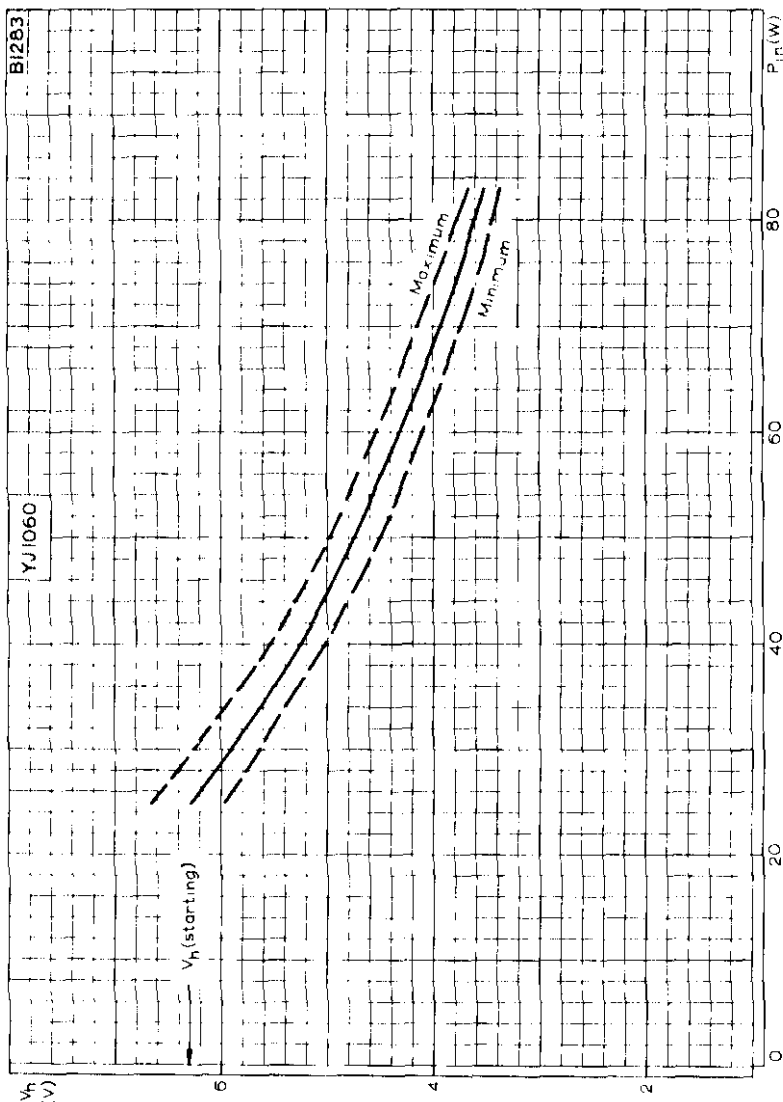

HEATER VOLTAGE PLOTTED AGAINST INPUT POWER



QUICK REFERENCE DATA

Fixed frequency 'X' band magnetron

Frequency	9.41	Gc/s
Power output (pulsed)	10.5	kW
Construction	Packaged, flying leads	

To be read in conjunction with

GENERAL OPERATIONAL RECOMMENDATIONS - MICROWAVE DEVICES

CHARACTERISTICS

	Min.	Max.	
Frequency fixed within the band	9.38	9.44	Gc/s
Pulse voltage ($I_{\text{pulse}} = 6.0\text{A}$)	5.5	5.9	kV
R.F. pulse power output ($I_{\text{pulse}} = 6.0\text{A}$)	9.0	-	kW
Frequency pulling (v.s.w.r. = 1.5)	-	15	Mc/s
Frequency temperature coefficient	-	-0.25	Mc/s per degC
Distance of v.s.w. minimum from face of mounting plate into valve	16.5	22.5	mm
Frequency pushing	-	2.0	Mc/s per A

OPERATING CONDITIONS

	Min.	Max.	
R. F. pulse power output	10.5	10.5	kW
Duty factor	0.0001	0.0005	
Pulse duration	0.1	0.5	μ s
Pulse repetition frequency	1000	1000	p.p.s.
Heater voltage (running)	6.3	6.3	V
Pulse current	6.0	6.0	A
Pulse voltage	5.7	5.7	kV
Pulse input power	34.8	34.8	kW
Rate of rise of voltage pulse	110	100	kV/ μ s
Mean input current	0.65*	3.0	mA
Mean input power	3.48	17.4	W
Mean r.f. output power	1.1	5.5	W
Frequency pulling (v.s.w.r. = 1.5)	14	14	Mc/s

*This includes pre-oscillation current.

CATHODE

Indirectly heated

V_h	6.3	V
I_h	0.55	A

Heating time

At ambient temperatures above 0°C the cathode must be heated for at least 2 minutes before the application of h.t. Below this temperature the heating time must be increased to at least 3 minutes.

For mean input powers greater than 25 watts, it is necessary to reduce the heater voltage immediately after the application of h.t. in accordance with the input power-heater voltage rating chart on page C2.

RATINGS (ABSOLUTE MAXIMUM SYSTEM)

	Min.	Max.	
Pulse current	4.5	7.0	A
Pulse duration	-	1.0	μ s
Duty factor	-	0.002	
Mean input power	-	85	W
Rate of rise of voltage pulse	-	120	kV/ μ s
Load mismatch (v.s.w.r.)	-	1.5	
Temperature of anode block	-	120	°C

END OF LIFE PERFORMANCE

The valve is deemed to have reached end of life when it fails to satisfy the following:

R. F. pulse power output ($I_{\text{pulse}} = 6.0\text{A}$)	7.0		kW
	Min.	Max.	
Frequency fixed within the band	9.38	to 9.44	Gc/s
Pulse voltage ($I_{\text{pulse}} = 6.0\text{A}$)	5.5	to 6.0	kV

MOUNTING POSITION

Any

PHYSICAL DATA

	lb	kg	
Weight of magnetron	3.0	1.4	
Weight of magnetron in carton	5.7	2.5	
	in		cm
Dimensions of storage carton	7.75 × 8.0 × 9.75		20 × 21 × 25

COOLING

In normal circumstances natural cooling is adequate, but when the ambient temperature is abnormally high a flow of cooling air between the cooling fins may be necessary to keep the anode block temperature below the permitted maximum.

B4828

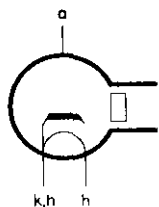

Cathode - Yellow lead
Heater - Green lead

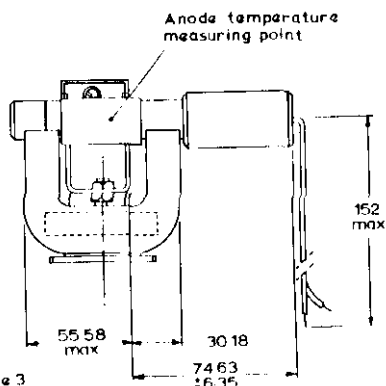
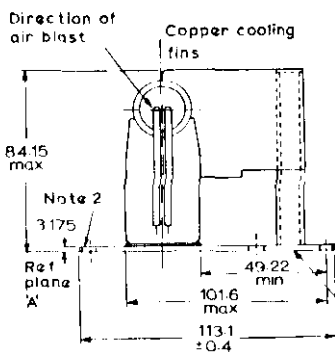
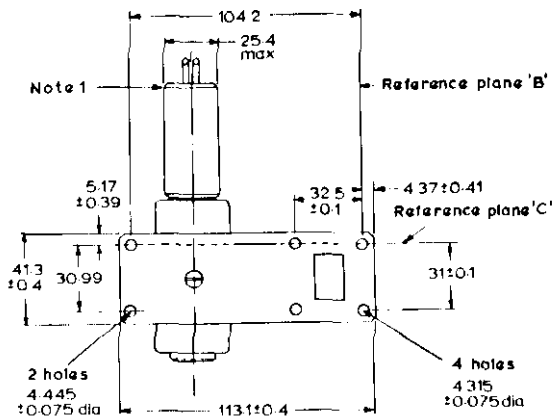

All dimensions in mm

NOTES

1. The protector sleeve shall be within 5° of a normal to reference plane C.
2. A cylinder 0.33in (8.38mm) diameter centred in the holes shown shall clear the side of the magnet.
3. The outlet via the waveguide WG16 is to take a bolted flange choke coupling, Joint Services type 5985-99-0830051.



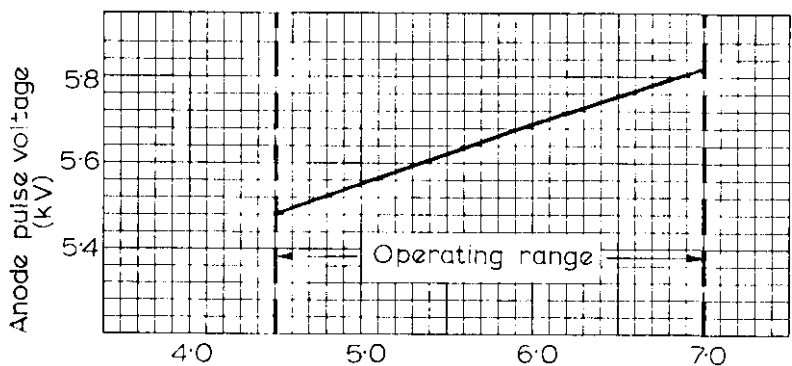
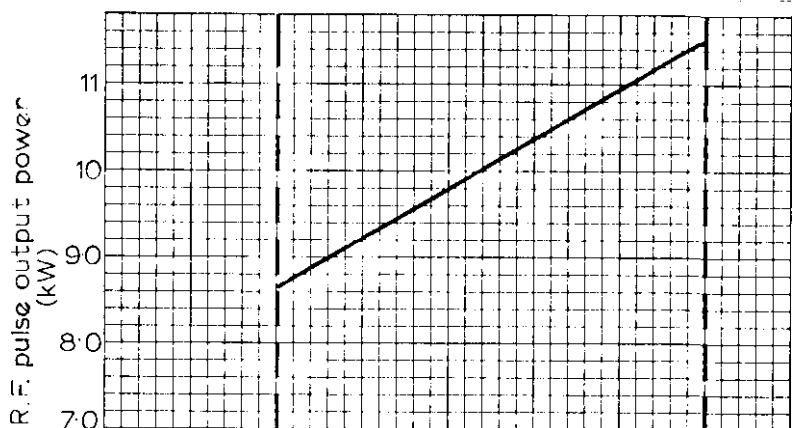
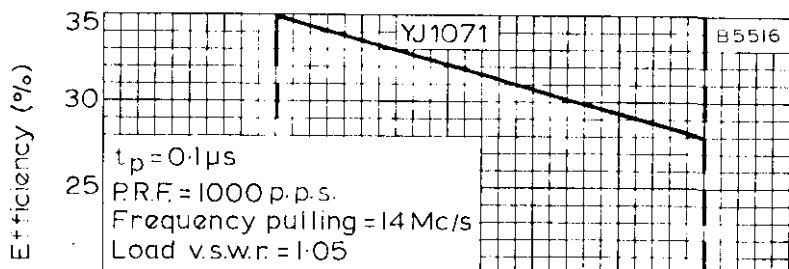

Anode pulse current (A)

ANODE PULSE VOLTAGE, R.F. PULSE OUTPUT POWER AND EFFICIENCY PLOTTED AGAINST ANODE PULSE CURRENT

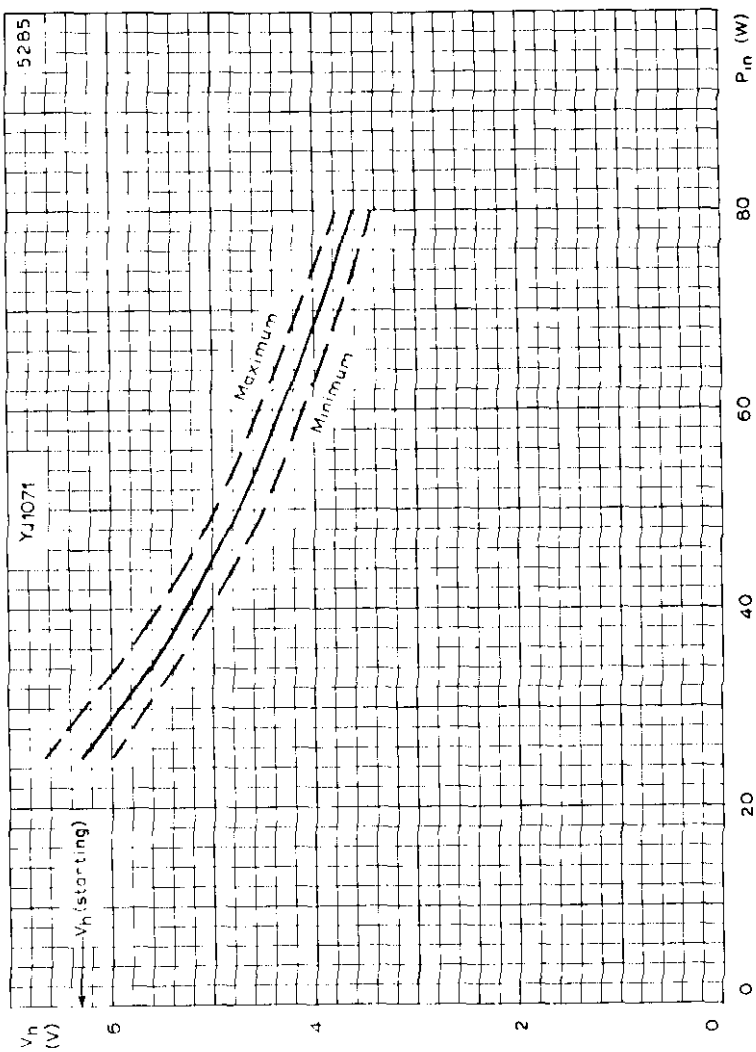

HEATER VOLTAGE PLOTTED AGAINST INPUT POWER

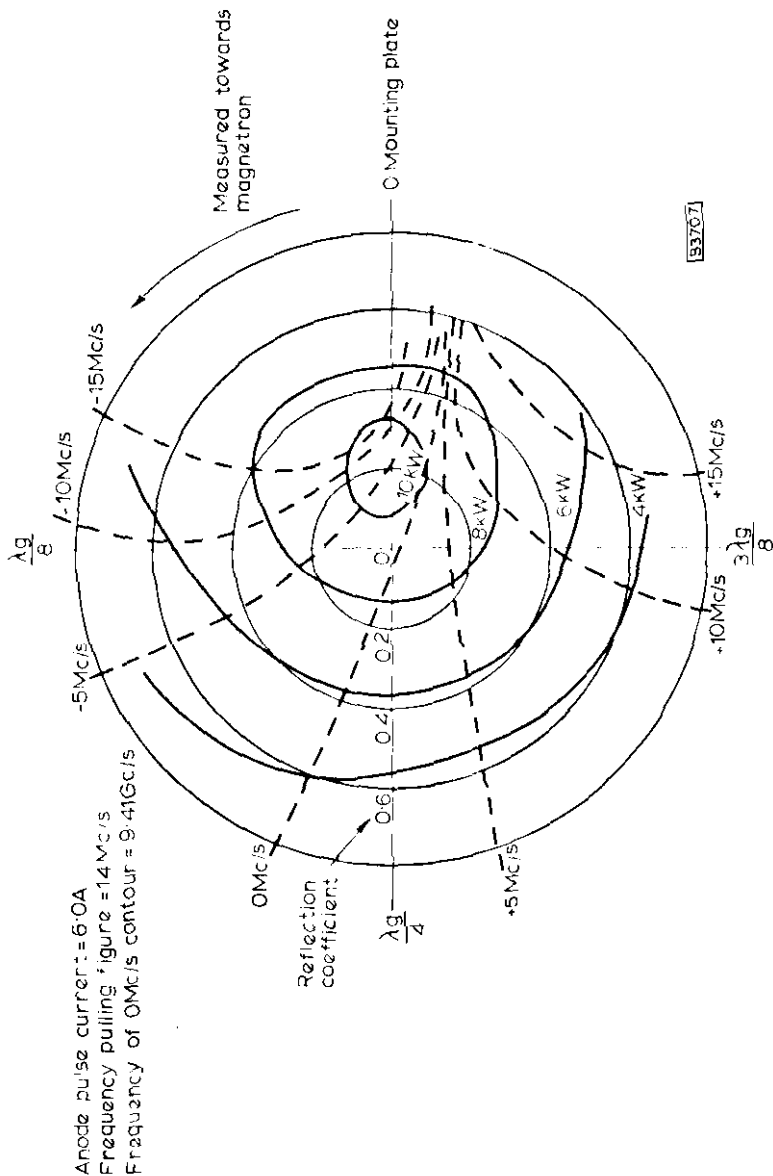

RIEKE DIAGRAM

TENTATIVE DATA

QUICK REFERENCE DATA

Mechanically tunable rugged magnetron with low frequency temperature coefficient and pulling figure. Suitable for high altitude operation.

	YJ1090	9.0 to 9.5	Gc/s
Frequency	YJ1091	8.5 to 9.0	Gc/s
Power output (pulsed)		50	W

To be read in conjunction with GENERAL OPERATIONAL RECOMMENDATIONS-MICROWAVE DEVICES.

Unless otherwise shown data is applicable to both types.
CHARACTERISTICS

		Min.	Max.	
Frequency	YJ1090	9.0	9.5	Gc/s
Tunable over the range	YJ1091	8.5	9.0	Gc/s
Pulse voltage (I pulse = 0.9 A)		1.025	1.350	kV
R. F. pulse power output (I pulse = 0.9 A)		30	-	W
Frequency pulling (v. s. w. r. = 1.5)		-	3.0	Mc/s
Frequency temperature coefficient over the range T anode 60 to 100°C		-	0.1	Mc/s per °C
Frequency modulation under vibration of 12g (50-2000c/s)			3.0	Mc/s
Input capacitance		-	6.0	pF
Frequency pushing (I pulse = 0.9 A)		-	25	kc/s per mA

TYPICAL OPERATION at $f = 9.25\text{Gc/s}$ (YJ1090) and $f = 8.75\text{Gc/s}$ (YJ1091)

R. F. pulse power output		50	W
Duty factor		0.002	
Pulse duration		1.0	μs
Pulse repetition frequency		2000	p. p. s.
Heater voltage (running)		5.0	V
Pulse current		0.9	A
Pulse voltage		1.18	kV
Pulse input power		1.06	kW
Rate of rise of voltage pulse		8.0	kV/μs
Mean input current		1.8	mA
Mean input power		2.12	W
Mean r. f. output power		100	mW
Frequency pulling (v. s. w. r. = 1.5)		1.9	Mc/s
Frequency pushing		10	kc/s per mA



CATHODE

Indirectly heated

Vh	5.0	V
Ih	0.5	A

Heating time. At ambient temperatures above 0°C the cathode must be heated for at least 0.5 minute before the application of h.t.

ABSOLUTE MAXIMUM RATINGS

	Min.	Max.	
Pulse current	0.7	1.1	A
Pulse duration	-	2.0	μs
Duty factor	-	0.004	
Mean input power	-	6.0	W
Rate of rise of voltage pulse	-	10.0	kV/μs
Load mismatch (v. s. w. r.)	-	1.5	
Temperature of anode block	-	100	°C

END OF LIFE PERFORMANCE

The valve is deemed to have reached end of life when it fails to satisfy the following: -

R. F. pulse power output (I pulse = 0.9 A)		20	W
	Min.	Max.	
Over the frequency band	YJ1090 YJ1091	9.0 to 8.5	Gc/s
Pulse voltage (I pulse = 0.9 A)		1.025 to 1.350	kV

MOUNTING POSITION

Any

COOLING

In normal circumstances natural cooling is adequate but where the ambient temperature is abnormally high, or where convection cooling is restricted, provision for conduction cooling may be made by a clamp, of non magnetic material, around the body.

OPERATING NOTE

Adjustment of the tuning mechanism beyond the stated frequency limits must not be attempted.

PHYSICAL DATA

	lb	kg
Weight of magnetron	0.5	0.23

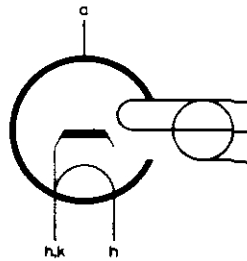
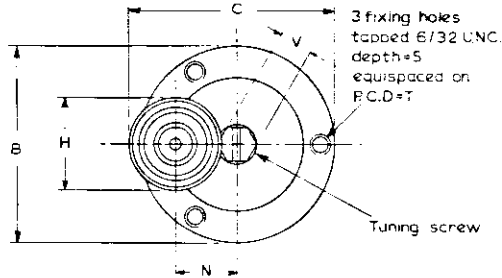
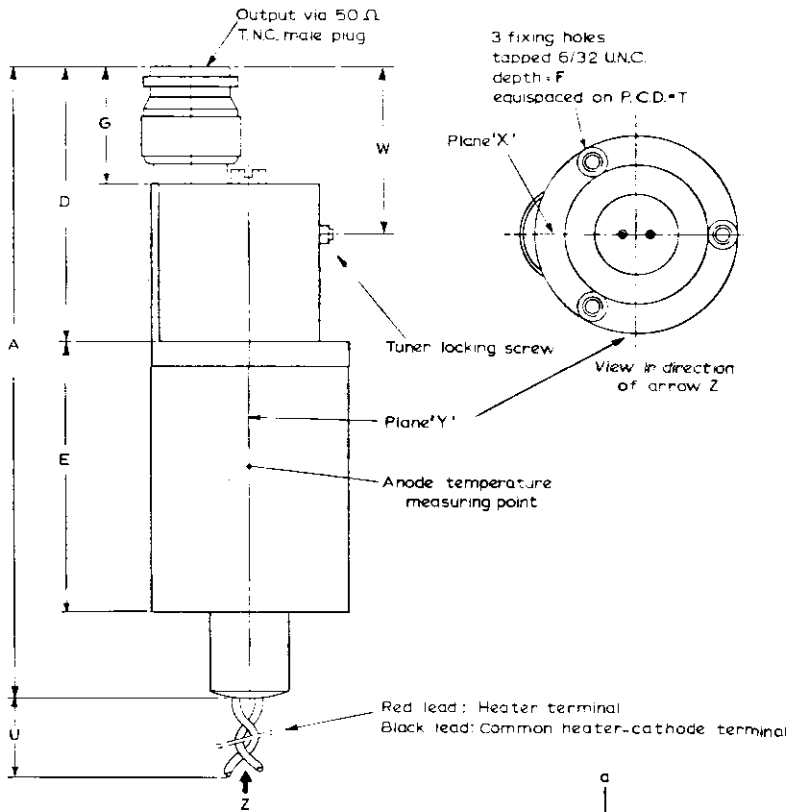

B2165

DIMENSIONS

	Inches	Millimetres
A	4.006 ± 0.069	101.75 ± 1.75
B	1.270 ± 0.010	32.25 ± 0.25
C	1.346 ± 0.010	34.25 ± 0.25
D	1.742 ± 0.030	44.25 ± 0.75
E	1.644 ± 0.014	41.75 ± 0.35
F	0.207 ± 0.010	5.25 ± 0.25
G	0.709 ± 0.008	18 ± 0.2
H	0.640	16.25 max.
N	0.394 ± 0.010	10.0 ± 0.25
S	0.167 ± 0.010	4.25 ± 0.25
T	1.063	27.0
U	8.0	203 min.
V	0.192 ± 0.001	4.875 ± 0.025
W	1.024 ± 0.016	26 ± 0.4

Inch dimensions derived from original millimetre dimensions.

TENTATIVE DATA

QUICK REFERENCE DATA

Mechanically tunable rugged magnetron with low frequency temperature coefficient, suitable for high altitude operation.

Frequency	YJ1100	9.0 to 9.5	Gc/s
	YJ1101	8.5 to 9.0	Gc/s
Power output (pulsed)		180	W

To be read in conjunction with GENERAL OPERATIONAL RECOMMENDATIONS-MICROWAVE DEVICES.

Unless otherwise shown data is applicable to both types.

CHARACTERISTICS

		Min.	Max.	
Frequency	YJ1100	9.0	9.5	Gc/s
Tunable over the range	YJ1101	8.5	9.0	Gc/s
Pulse voltage (I pulse = 0.9 A)		1.025	1.350	kV
R. F. pulse power output (I pulse = 0.9 A)		150	-	W
Frequency pulling (v. s. w. r. = 1.5)		-	15	Mc/s
Frequency temperature coefficient over the range T anode 60 to 100°C		-	0.1	Mc/s per °C
Frequency modulation under vibration of 12g (50-2000c/s)		-	3.0	Mc/s
Input capacitance		-	6.0	pF
Frequency pushing (I _{pulse} = 0.9 A)		-	25	kc/s per mA

TYPICAL OPERATION at $f = 9.25\text{Gc/s}$ (YJ1100) and $f = 8.75\text{Gc/s}$ (YJ1101)

R. F. pulse power output	180	W
Duty factor	0.002	
Pulse duration	1.0	μs
Pulse repetition frequency	2000	p. p. s.
Heater voltage (running)	5.0	V
Pulse current	0.9	A
Pulse voltage	1.18	kV
Pulse input power	1.06	kW
Rate of rise of voltage pulse	10	kV/μs
Mean input current	1.8	mA
Mean input power	2.12	W
Mean r. f. output power	0.36	W
Frequency pulling (v. s. w. r. = 1.5)	10	Mc/s
Frequency pushing	10	kc/s per mA

CATHODE

Indirectly heated

V _h	5.0	V
I _h	0.5	A

Heating time. At ambient temperatures above 0°C the cathode must be heated for at least 30 seconds before the application of h.t.

ABSOLUTE MAXIMUM RATINGS

	Min.	Max.	
Pulse current	0.7	1.1	A
Pulse duration	-	2.0	μs
Duty factor	-	0.004	
Mean input power	-	6.0	W
Rate of rise of voltage pulse	-	12	kV/μs
Load mismatch (v.s.w.r.)	-	1.5	
Temperature of anode block	-	100	°C

END OF LIFE PERFORMANCE

The valve is deemed to have reached end of life when it fails to satisfy the following: -

R. F. pulse power output (I pulse = 0.9 A) 120 W

Pulse voltage (I pulse = 0.9 A) 1.025 to 1.350 kV

MOUNTING POSITION

Any

PHYSICAL DATA

	lb	kg
Weight of magnetron	0.5	0.23

COOLING

In normal circumstances natural cooling is adequate but where the ambient temperature is abnormally high, or where convection cooling is restricted, provision for conduction cooling may be made by a clamp, of non-magnetic material, around the body.

OPERATING NOTE

Adjustment of the tuning mechanism beyond the stated frequency limits must not be attempted.

DIMENSIONS

	Inches	Millimetres	
A	4.006 ± 0.069	101.75 ± 1.75	
B	1.270 ± 0.010	32.25 ± 0.25	
C	1.348 ± 0.010	34.25 ± 0.25	
D	1.742 ± 0.030	44.25 ± 0.75	
E	1.644 ± 0.014	41.75 ± 0.35	
F	0.207 ± 0.010	5.25 ± 0.25	
G	0.709 ± 0.008	18 ± 0.2	
H	0.640	16.25	max.
N	0.394 ± 0.010	10.0 ± 0.25	
S	0.167 ± 0.010	4.25 ± 0.25	
T	1.063	27.0	
U	8.0	203	min.
V	0.192 ± 0.001	4.875 ± 0.025	
W	1.024 ± 0.016	26 ± 0.4	

Inch dimensions derived from original millimetre dimensions.

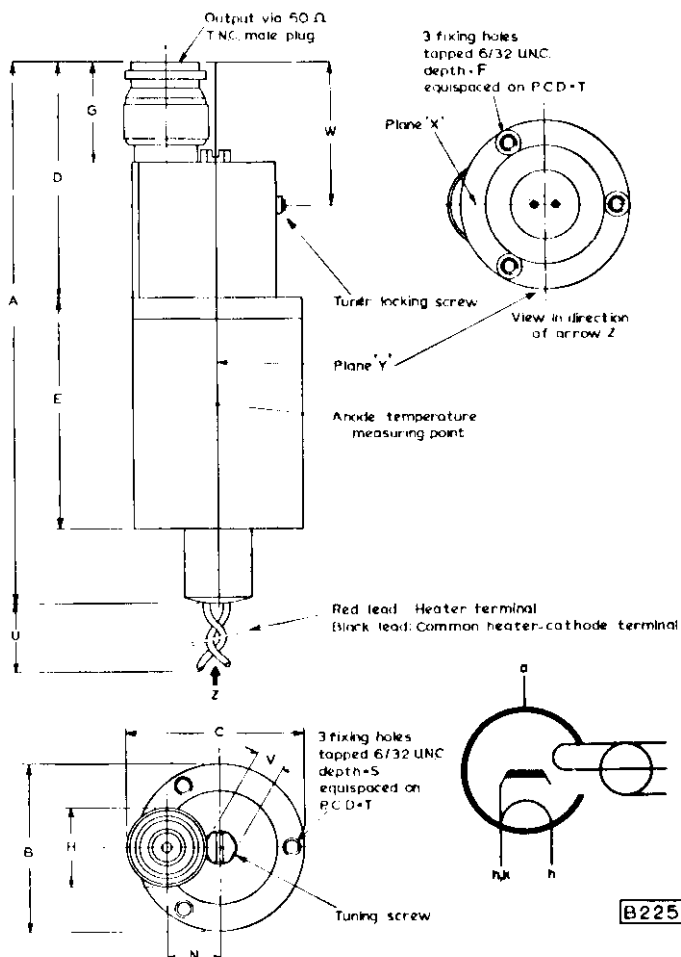

QUICK REFERENCE DATA

Fixed frequency 'X' band magnetron

Frequency YJ1110	9.345 to 9.405	Gc/s
YJ1111	9.415 to 9.475	Gc/s
Power output	20	kW
Construction		Packaged

Unless otherwise shown, data is applicable to both types

To be read in conjunction with
GENERAL OPERATIONAL RECOMMENDATIONS - MICROWAVE DEVICES
CHARACTERISTICS

	Min.		Max.
Frequency YJ1110	9.345	to	9.405 Gc/s
YJ1111	9.415	to	9.475 Gc/s
Pulse voltage ($I_{\text{pulse}} = 7.5\text{A}$)	7.0		8.2 kV
R. F. pulse power output ($I_{\text{pulse}} = 7.5\text{A}$)	17		- kW
Frequency pulling (v.s.w.r. = 1.5)	-		18 Mc/s
Frequency temperature coefficient	-		-0.25 Mc/s per degC
Distance of v.s.w. minimum from face of mounting plate into valve	16.5		22.5 mm
Input capacitance	-		8.0 pF
Frequency pushing	-		1.5 Mc/s per A

OPERATING CONDITIONS

R. F. pulse power output	20	20	20	kW
Duty factor	0.0005	0.0001	0.0005	
Pulse duration	0.5	0.1	0.05	μ s
Pulse repetition frequency	1000	1000	1000	p.p.s.
Heater voltage (running)	6.3	6.3	6.3	V
Pulse current	7.5	7.5	7.5	A
Pulse voltage	7.8	7.8	7.8	kV
Pulse input power	58.5	58.5	58.5	kW
Rate of rise of voltage pulse	80	100	100	kV/ μ s
*Mean input current	3.75	0.8	0.425	mA
Mean input power	29	6.2	3.3	W
Mean r.f. output power	10	2.0	1.0	W
Frequency pulling (v.s.w.r. = 1.5)	16	16	16	Mc/s

*Includes pre-oscillation current.

CATHODE

Indirectly heated

V_h	6.3	V
I_h	0.55	A
r_h (cold)	1.75	Ω
$I_{h(\text{surge})}$ max.	5.0	A

Heating time. At ambient temperatures above 0°C the cathode must be heated for at least 2.0 minutes before the application of h.t. Below this temperature the heating time must be increased to at least 3.0 minutes.

For mean input powers greater than 25 watts, it is necessary to reduce the heater voltage immediately after the application of h.t. in accordance with the input power/heater voltage rating chart on page C3.

RATINGS (ABSOLUTE MAXIMUM SYSTEM)

	Min.	Max.	
Pulse current ($t_p \leq 1.0\mu s$)	6.0	9.0	A
($t_p > 1.0\mu s$)	6.0	7.5	A
Pulse duration	0.05	2.5	μs
Duty factor	-	0.0015	
Mean input power	-	85	W
Rate of rise of voltage pulse	-	120	kV/ μs
Load mismatch (v.s.w.r.)	-	1.5	
Temperature of anode block	-	120	$^{\circ}C$

END OF LIFE PERFORMANCE

The valve is deemed to have reached end of life when it fails to satisfy the following:-

R. F. pulse power output ($I_{pulse} = 7.5A$)		14	kW
	Min.	Max.	
Frequency YJ1110	9.345	to	9.405 Gc/s
YJ1111	9.415	to	9.475 Gc/s
Pulse voltage ($I_{pulse} = 7.5A$)	7.0	to	8.4 kV

MOUNTING POSITION

Any

PHYSICAL DATA

	lb	kg
Weight of magnetron	3.3	1.5
Weight of magnetron in carton	6.4	2.9
	in	cm
Dimensions of storage carton	7.8 × 8.0 × 9.8	19.7 × 20.4 × 24.8

COOLING

In normal circumstances natural cooling is adequate, but where the ambient temperature is abnormally high, a flow of cooling air between the radiator fins may be necessary to keep the block temperature below the permitted maximum.

B 5631

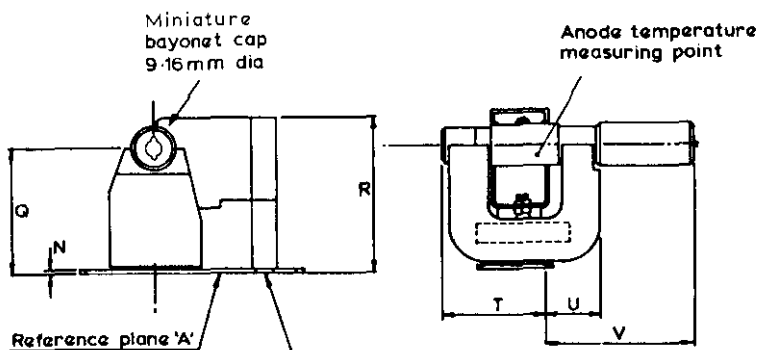
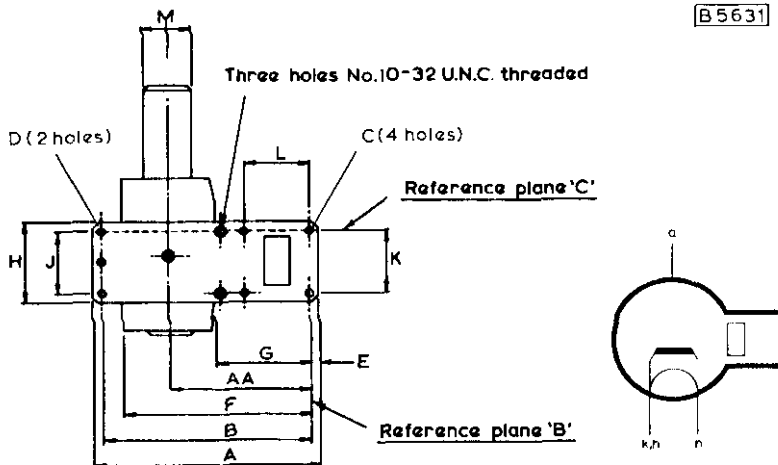

Outlet via WG16(R100;WR90) to take bolted flange choke coupling Joint Services type 5985-99-0830051.

DIMENSIONS

	Inches	Millimetres	
A	4.468	113.5	max.
B	4.102 ± 0.004	104.2 ± 0.10	
C	0.170 ± 0.003	4.32 ± 0.08	dia.
D	0.175 ± 0.003	4.45 ± 0.08	dia.
E	0.188	4.80	max.
F	4.01	102	max.
G	1.851	47.00	min.
H	1.641	41.70	max.
J	1.220 ± 0.003	30.99 ± 0.08	
K	1.220 ± 0.003	30.99 ± 0.08	
L	1.280 ± 0.004	32.51 ± 0.10	
M	1.000	25.40	max. dia.
N	0.125 ± 0.009	3.18 ± 0.25	
Q	2.56 ± 0.12	65 ± 3.0	
R	3.307	84.00	max.
T	2.165	55.00	max.
U	1.102	28.00	max.
V	3.070	78.00	max.
AA	2.99 ± 0.12	76 ± 3.0	

Inch dimensions derived from original millimetre dimensions

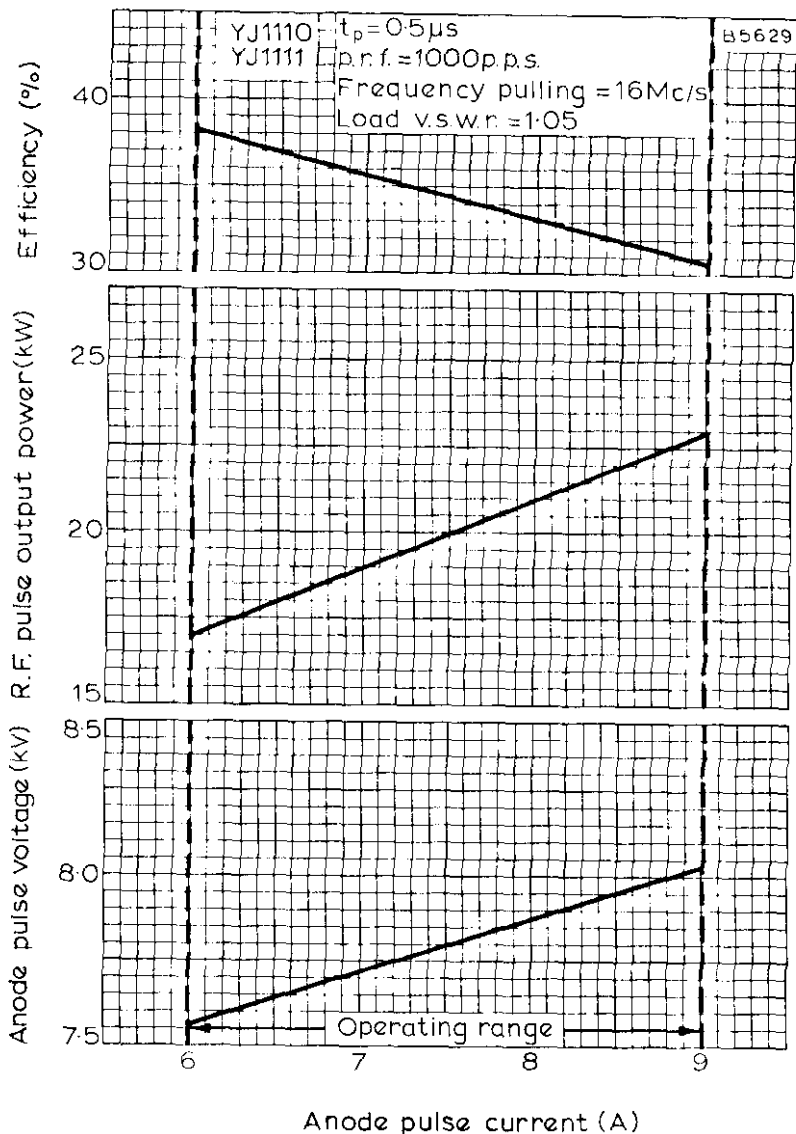

ANODE PULSE VOLTAGE, R. F. PULSE OUTPUT POWER AND EFFICIENCY
PLOTTED AGAINST ANODE PULSE CURRENT

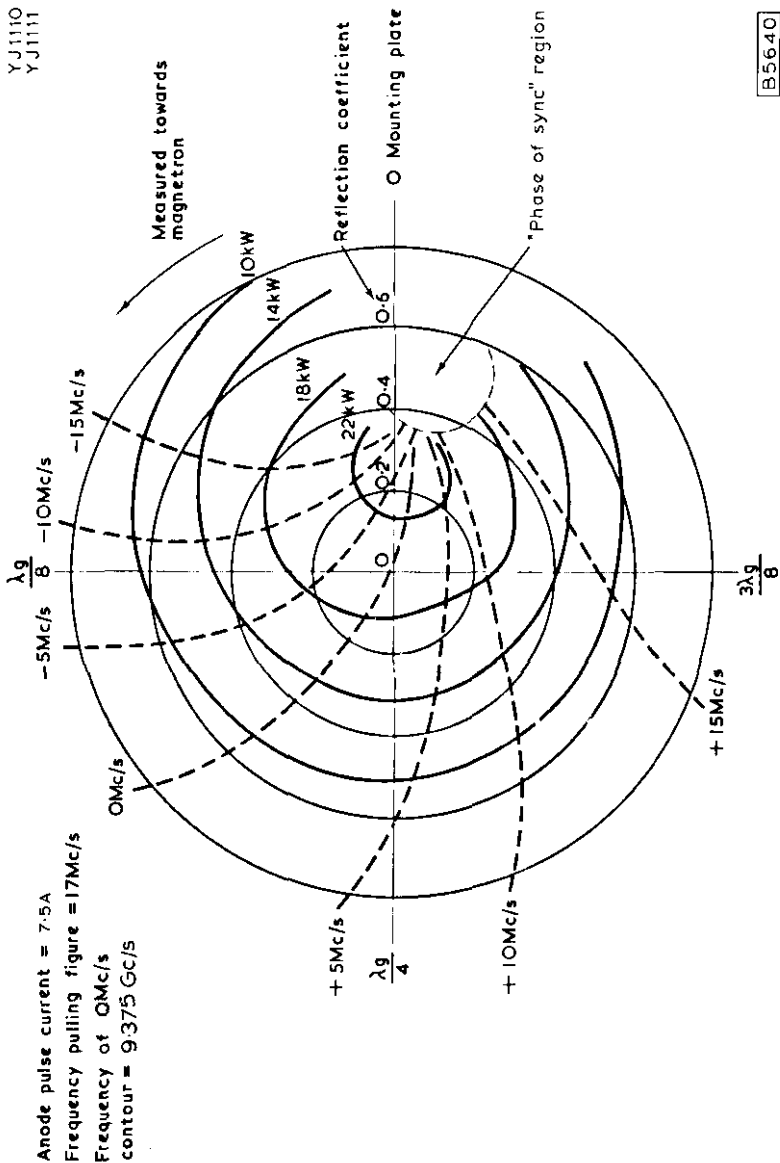

Anode pulse current = 7.5A
 Frequency pulling figure = 17Mc/s
 Frequency of OMc/s
 contour = 9.375 Gc/s

RIEKE DIAGRAM



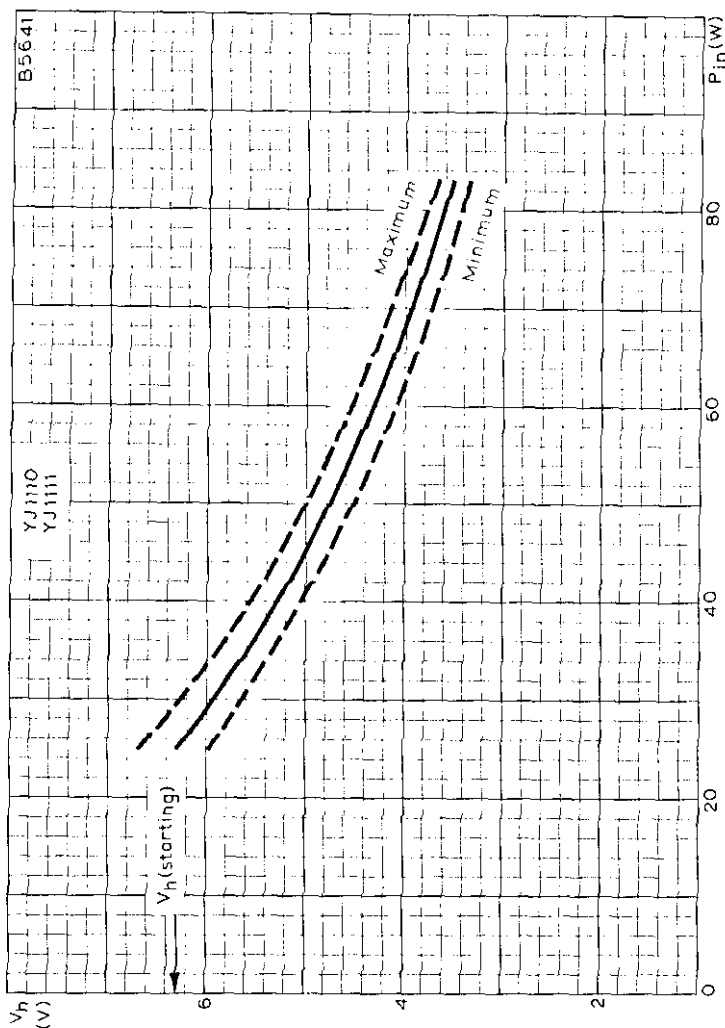

HEATER VOLTAGE PLOTTED AGAINST MEAN INPUT POWER

QUICK REFERENCE DATA

Fixed frequency 'X' band magnetron

Frequency	9.380 to 9.440	Gc/s
Power output	25	kW
Construction	Packaged, flying leads	

To be read in conjunction with
GENERAL OPERATIONAL RECOMMENDATIONS - MICROWAVE DEVICES

CHARACTERISTICS

	Min.	Max.	
Frequency fixed within the band	9.380	9.440	Gc/s
Pulse voltage ($I_{\text{pulse}} = 8.0\text{A}$)	7.5	8.5	kV
R.F. pulse power output ($I_{\text{pulse}} = 8.0\text{A}$)	20	-	kW
Frequency pulling (v.s.w.r. = 1.5)	-	18	Mc/s
Frequency temperature coefficient	-	-0.25	Mc/s per degC
Distance of v.s.w. minimum from face of mounting plate into valve	16.5	22.5	mm
Input capacitance	-	8.0	pF
Frequency pushing	-	1.5	Mc/s per A

OPERATING CONDITIONS

R. F. pulse power output	25	25	25	25	kW
Duty factor	0.0001	0.00015	0.0005	0.0006	
Pulse duration	0.05	0.15	0.5	1.2	μ s
Pulse repetition frequency	2000	1000	1000	500	p.p.s.
Heater voltage (running)	6.3	6.3	6.3	6.3	V
Pulse current	8.0	8.0	8.0	8.0	A
Pulse voltage	8.2	8.2	8.2	8.2	kV
Pulse input power	66	66	66	66	kW
Rate of rise of voltage pulse	120	120	100	100	kV/ μ s
Mean input current	*0.85	*1.25	4.0	4.8	mA
Mean input power	6.4	9.6	32	38.4	W
Mean r.f. output power	2.5	3.75	12.5	15	W
Frequency pulling (v.s.w.r. = 1.5)	16	16	16	16	Mc/s

*Includes pre-oscillation current.

CATHODE

Indirectly heated

V_h	6.3	V
I_h	0.55	A
r_h (cold)	1.75	Ω
$I_{h(\text{surge})}$ max.	5.0	A

Heating time. At ambient temperatures above 0°C the cathode must be heated for at least 2.0 minutes before the application of h.t. Below this temperature the heating time must be increased to at least 3.0 minutes.

RATINGS (ABSOLUTE MAXIMUM SYSTEM)

	Min.	Max.	
Pulse current	6.0	9.5	A
Pulse duration	-	1.5	μ s
Duty factor	-	0.0015	
Mean input power	-	85	W
Rate of rise of voltage pulse	-	120	kV/ μ s
Load mismatch (v.s.w.r.)	-	1.5	
Temperature of anode block	-	120	°C

END OF LIFE PERFORMANCE

The valve is deemed to have reached end of life when it fails to satisfy the following:

R. F. pulse power output ($I_{\text{pulse}} = 8.0\text{A}$)		16		kW
	Min.		Max.	
Frequency fixed within the band	9,380	to	9,440	Gc/s
Pulse voltage ($I_{\text{pulse}} = 8.0\text{A}$)	7.5	to	8.7	kV

MOUNTING POSITION

Any

PHYSICAL DATA

	lb		kg
Weight of magnetron	3.3		1.5
Weight of magnetron in carton	6.4		2.9
	in		cm
Dimensions of storage carton	7.8 × 8.0 × 9.8		19.7 × 20.4 × 24.8

COOLING

In normal circumstances natural cooling is adequate, but where the ambient temperature is abnormally high, a flow of cooling air between the radiator fins may be necessary to keep the anode block temperature below the permitted maximum.

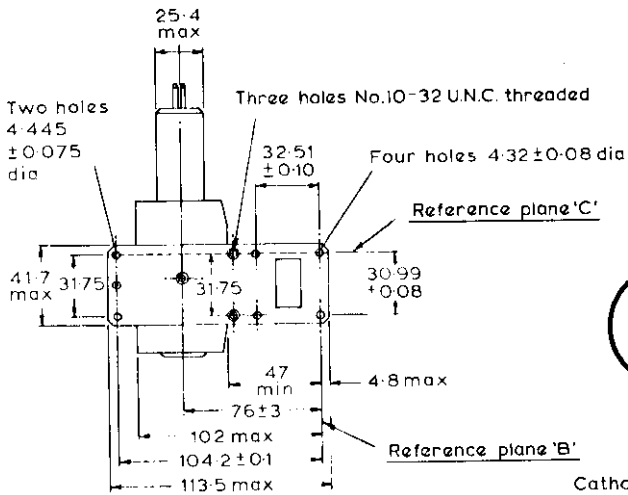

Cathode = Yellow lead
Heater = Green lead

Anode temperature
measuring point

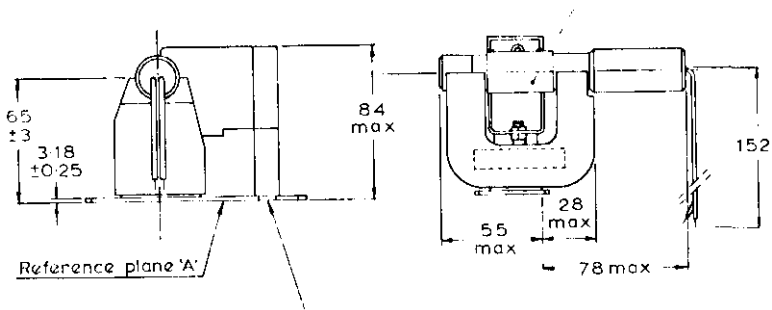

Outlet via WG16(R100,WR90) to take
bolted flange choke coupling Joint
Services type 5985-99-0830051.

All dimensions in mm

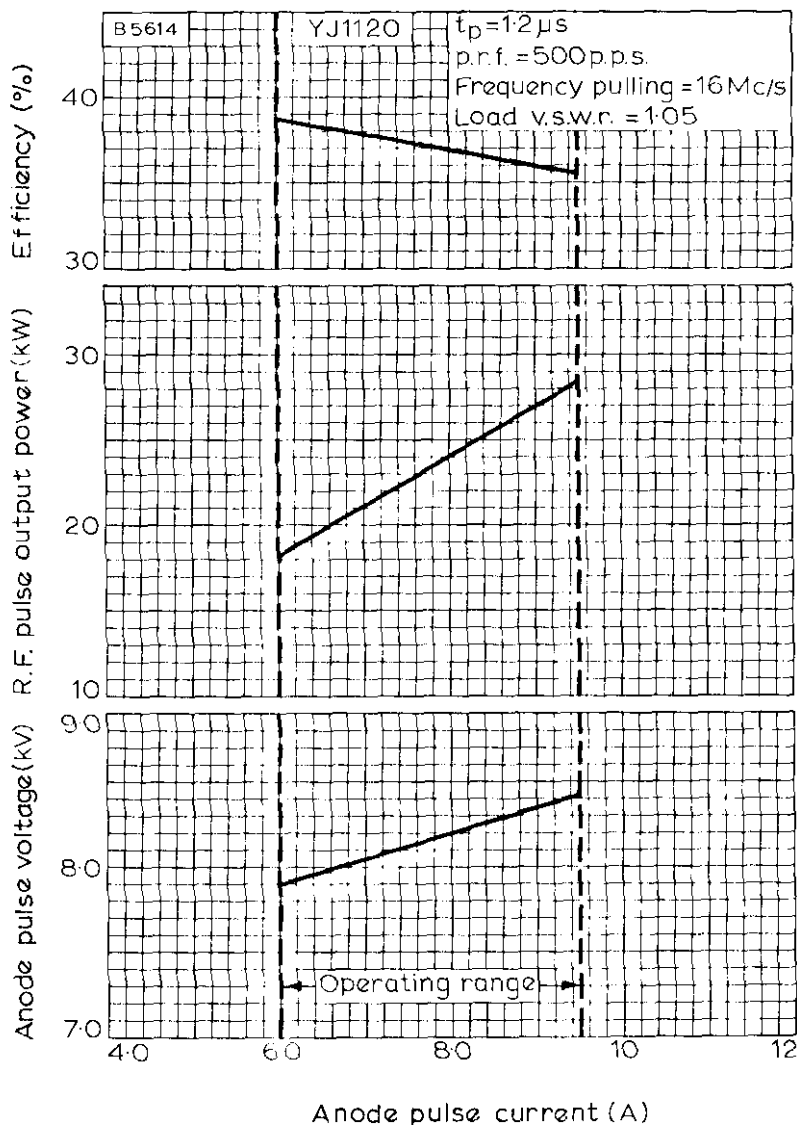

ANODE PULSE VOLTAGE, R. F. PULSE OUTPUT POWER AND EFFICIENCY PLOTTED AGAINST ANODE PULSE CURRENT

TENTATIVE DATA

QUICK REFERENCE DATA

Fixed frequency 'X' Band Magnetron

Frequency	9.415 to 9.475	Gc/s
Power output	26	kW
Construction	Packaged, flying leads	

To be read in conjunction with

GENERAL OPERATIONAL RECOMMENDATIONS - MICROWAVE DEVICES

CHARACTERISTICS

	Min.	Max.	
Frequency	9.415	9.475	Gc/s
Pulse voltage ($I_{\text{pulse}} = 9.0\text{A}$)	7.5	8.5	kV
R. F. pulse power output ($I_{\text{pulse}} = 9.0\text{A}$)	22	-	kW
Frequency pulling (v. s. w. r. ≈ 1.5)	-	18	Mc/s
Frequency temperature coefficient	-	-0.25	Mc/s per degC
Distance of v. s. w. minimum from face of mounting plate into valve	16.5	22.5	mm
Input capacitance	-	8.0	pF
Frequency pushing	-	1.5	Mc/s per A

OPERATING CONDITIONS

R. F. pulse power output	26	26	26	26	kW
Duty factor	0.0001	0.00015	0.0005	0.0006	
Pulse duration	0.05	0.15	0.5	1.2	μs
Pulse repetition frequency	2000	1000	1000	500	p. p. s.
Heater voltage (running)	6.3	6.3	6.3	6.3	V
Pulse current	9.0	9.0	9.0	9.0	A
Pulse voltage	8.3	8.3	8.3	8.3	kV
Pulse input power	75	75	75	75	kW
Rate of rise of voltage pulse	120	120	100	100	kV/ μs
Mean input current	*0.95	*1.4	4.5	5.4	mA
Mean input power	7.9	11.7	35.5	15	W
Mean r. f. output power	2.6	3.9	13.0	15.6	W
Frequency pulling (v. s. w. r. = 1.5)	16	16	16	16	Mc/s

*Includes pre-oscillation current.

CATHODE

Indirectly heated

V_h	6.3	V
I_h	0.6	A
r_h (cold)	1.75	Ω
I_h (surge) max.	5.0	A

Heating time

At ambient temperatures above 0°C the cathode must be heated for at least 2.0 minutes before the application of h.t. Below this temperature the heating time must be increased to at least 3.0 minutes.

RATINGS (ABSOLUTE MAXIMUM SYSTEM)

	Min.	Max.	
Pulse current	6.0	10	A
Pulse duration	-	1.5	μs
Duty factor	-	0.0015	
Mean input power	-	85	W
Rate of rise of voltage pulse	-	120	kV/ μs
Load mismatch (v.s.w.r.)	-	1.5	
Temperature of anode block	-	120	°C
Temperature of cathode and heater seals	-	120	°C

END OF LIFE PERFORMANCE

The valve is deemed to have reached end of life when it fails to satisfy the following:-

R. F. pulse power output ($I_{\text{pulse}} = 9.0 \text{ A}$) 18 kW

	Min.	Max.	
Frequency			
Within the band	9.415 to	9.475	Gc/s
Pulse voltage ($I_{\text{pulse}} = 9.0 \text{ A}$)	7.5 to	8.5	kV

MOUNTING POSITION

Any

PHYSICAL DATA

	lb	kg
Weight of magnetron	3.0	1.4
Weight of magnetron in carton	6.4	2.9
	in	cm
Dimensions of storage carton	7.8 × 8.0 × 9.8	19.8 × 20.3 × 24.9

COOLING Natural

In normal circumstances natural cooling is adequate, but where the ambient temperature is abnormally high, a flow of cooling air between the radiator fins may be necessary to keep the block temperature below the permitted maximum.

B5479

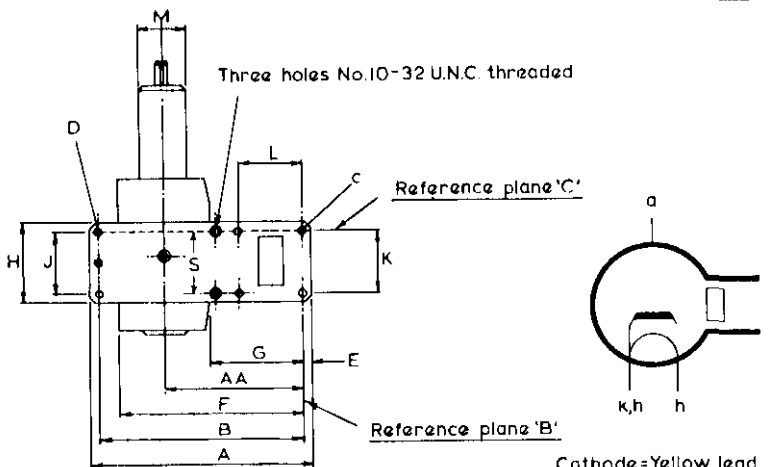

Cathode = Yellow lead
Heater = Green lead

Anode temperature
measuring point

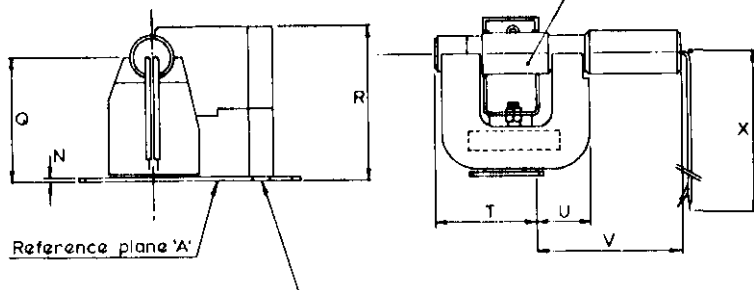

Outlet via WG16(R100,WR90) to take
bolted flange choke coupling Joint
Services type 5985-99-0830051



DIMENSIONS

	Inches	Millimetres	
A	4.467	113.5	max.
B	4.102 ± 0.004	104.2 ± 0.10	
C	0.170 ± 0.003	4.32 ± 0.08	dia.
D	0.175 ± 0.003	4.445 ± 0.075	dia.
E	0.189	4.80	max.
F	4.01	102	max.
G	1.850	47.00	min.
H	1.641	41.70	max.
J	1.250	31.75	nom.
K	1.220 ± 0.003	30.99 ± 0.08	
L	1.280 ± 0.004	32.51 ± 0.10	
M	1.000	25.40	max. dia.
N	0.125 ± 0.010	3.18 ± 0.25	
Q	2.559 ± 0.118	65 ± 3.0	
R	3.307	84.00	max.
S	1.250	31.75	nom.
T	2.165	55.00	max.
U	1.102	28.00	max.
V	3.070	78.00	max.
X	5.98	152	nom.
AA	2.992 ± 0.118	76 ± 3.0	

Inch dimensions derived from original millimetre dimensions

QUICK REFERENCE DATA

Pulsed magnetron tunable by means of an integral servo-motor over 450MHz sweep in 500 μ s.

Frequency	8.7 to 9.5	GHz
Power output	205	kW

Unless otherwise shown, data is applicable to all types

To be read in conjunction with

GENERAL OPERATIONAL RECOMMENDATIONS - MICROWAVE DEVICES

OPERATING CONDITIONS (at f = 9.075GHz centre \pm 250MHz range)

R.F. pulse power output	205	205	kW
Duty factor	0.0007	0.001	
Pulse duration	0.2	1.0	μ s
Pulse repetition frequency	3500	1000	p.p.s.
Heater voltage (running)	7.7	5.0	V
Pulse current	27.5	27.5	A
Pulse voltage	22.5	22.5	kV
Pulse input power	619	619	kW
Rate of rise of voltage pulse	200	180	kV/ μ s
Mean input current (I_{mean})	19.25	27.5	mA
Mean input power	433	619	W
Mean r.f. output power	143	205	W
Frequency pulling (v.s.w.r. = 1.5)	12	12	MHz

CATHODE

Indirectly heated

V_h	13.75 \pm 10%	V
I_h	3.15 \pm 10%	A
I_h (surge) max.	12	A

The valve heater shall be protected against arcing by the use of a connector that places a minimum capacitance of 4000pF across the heater directly at the input terminals.

Heating time. At ambient temperatures above 0 $^{\circ}$ C the cathode must be heated for at least 2.5 minutes before the application of h.t.

It is necessary to reduce the heater voltage immediately after the application of h.t. in accordance with the formula:

$$V_h = 13.75 \left(1 - \frac{I_{\text{mean}}}{43} \right)$$

CHARACTERISTICS

	Min.	Max.	
Frequency	8.7	9.5	GHz
*Frequency sweep	400	-	MHz
Pulse voltage ($I_{\text{pulse}} = 27.5\text{A}$)	21	24	kV
R.F. pulse power output ($I_{\text{pulse}} = 27.5\text{A}$)	180	-	kW
Frequency pulling (v.s.w.r. = 1.5)	-	15	MHz
Frequency temperature coefficient	-	-0.5	MHz/degC
Frequency pushing	-	0.5	MHz per A
Hot to cold frequency difference	9.0	16	MHz

*An alternative version (YJ1181) is available with an optional frequency lock. This allows the tube to be frequency locked to within 20MHz of any pre-determined frequency. The external dimensions remain unchanged.

RATINGS (ABSOLUTE MAXIMUM SYSTEM)

	Min.	Max.	
Pulse current	-	27.5	A
Pulse duration	0.15	1.5	μs
Duty factor	-	0.0011	
Mean input power	-	660	W
Rate of rise of voltage pulse			
Short pulse operation - up to $1.0\mu\text{s}$	-	200	kV/ μs
Long pulse operation - up to $2.0\mu\text{s}$	-	180	kV/ μs
Load mismatch (v.s.w.r.)	-	1.5	

TUNING

Tuning programme	16 full cycles per shaft revolution. One cycle consists of a quasi-sinusoidal scan through the entire tuning range and return.
Integral servo-motor	Navy Bu. Ord. Size 18 servo-motor N.A.T.O. number 6105-99-972-6555
Drive input	115V, 400Hz, fixed phase 115V, 400Hz, centre tapped control phase 9.2W/phase
Minimum drive speed	4000 r. p. m.



MOUNTING POSITION

Any

PRESSURISING

To prevent arcing the air pressure in the waveguide should not be less than 740 torr.

PHYSICAL DATA

	kg	lb
Weight of magnetron	6.8	15

COOLING

Forced-air cooling is required in order to keep the anode block temperature below the permitted maximum.

An air flow of approximately $0.85\text{m}^3/\text{min.}$ ($30\text{ft}^3/\text{min.}$) should be directed on the cooling fins.

Temperature

Anode block max.	120	$^{\circ}\text{C}$
------------------	-----	--------------------

OUTPUT CONNECTION

Suitable for connection to waveguide RG51/U (WG15, R84)

OPERATING NOTES

Tunable version with optional fixed frequency lock, YJ1181.

The lock consists of a small mechanical device mounted with the electrical connections to the two-phase, 400Hz drive motor.

It does not add to the volume or external dimensions of the magnetron as it is completely contained in the present housing for the motor cable connections. The only protruding part is the frequency adjustment screw, similar to those of conventional tunable magnetrons. The frequency trimming is made by means of a screw-driver or a flexible shaft to a knob for manual adjustment, or to a servo motor for remote monitoring. In the latter case the magnetron frequency may be kept as close as desired to a predetermined frequency by comparison with a resonant cavity in a closed servo loop.

The lock is actuated simply by reversing the phase order of the motor, thus letting the stalled torque work against a stop. The actuated lock keeps the tuner in a precisely defined angular position, corresponding to a predetermined frequency.

For a fixed operating point in steady state conditions the frequency can be locked to within 20MHz from any predetermined frequency within the tuning band without any adjustments, either manual or automatic. With the operating point varying within the specification, the frequency can still be kept within 35MHz. Under all conditions (transient or steady state) the locking frequency is kept within 60MHz from the predetermined frequency. See page D1.

OUTLINE AND DIMENSIONS OF YJ1180 AND YJ1181

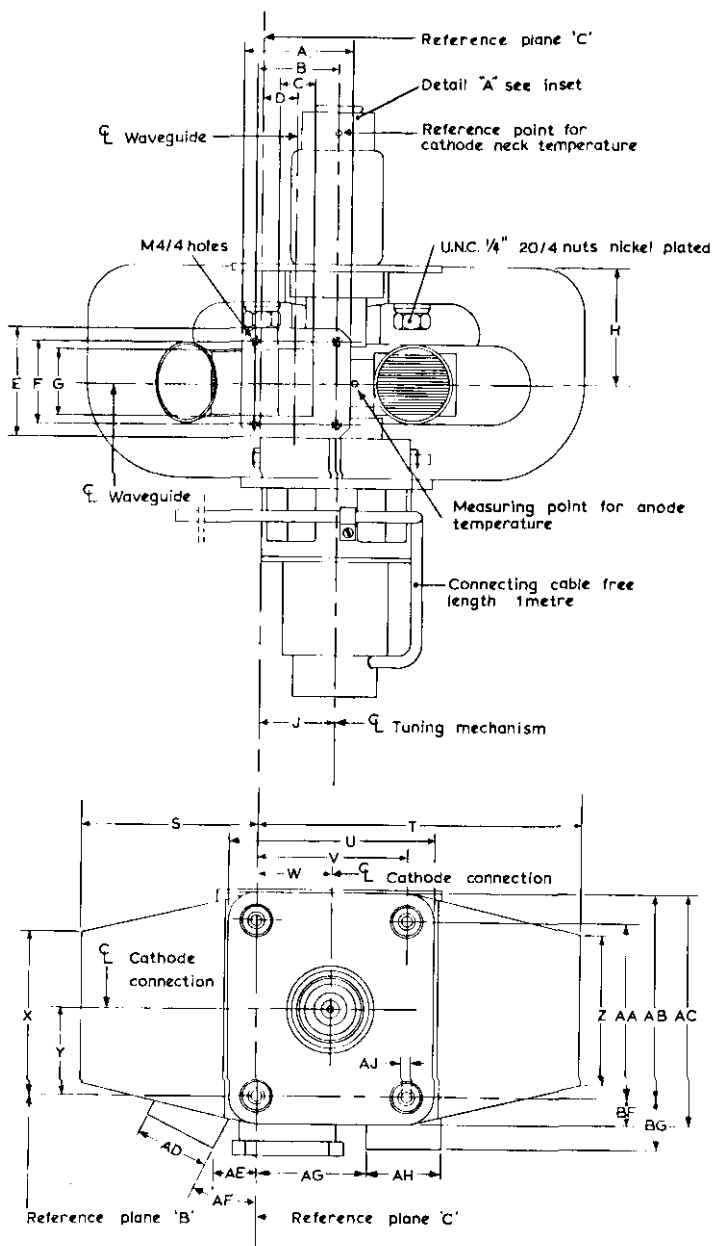

OUTLINE AND DIMENSIONS OF YJ1180 AND YJ1181

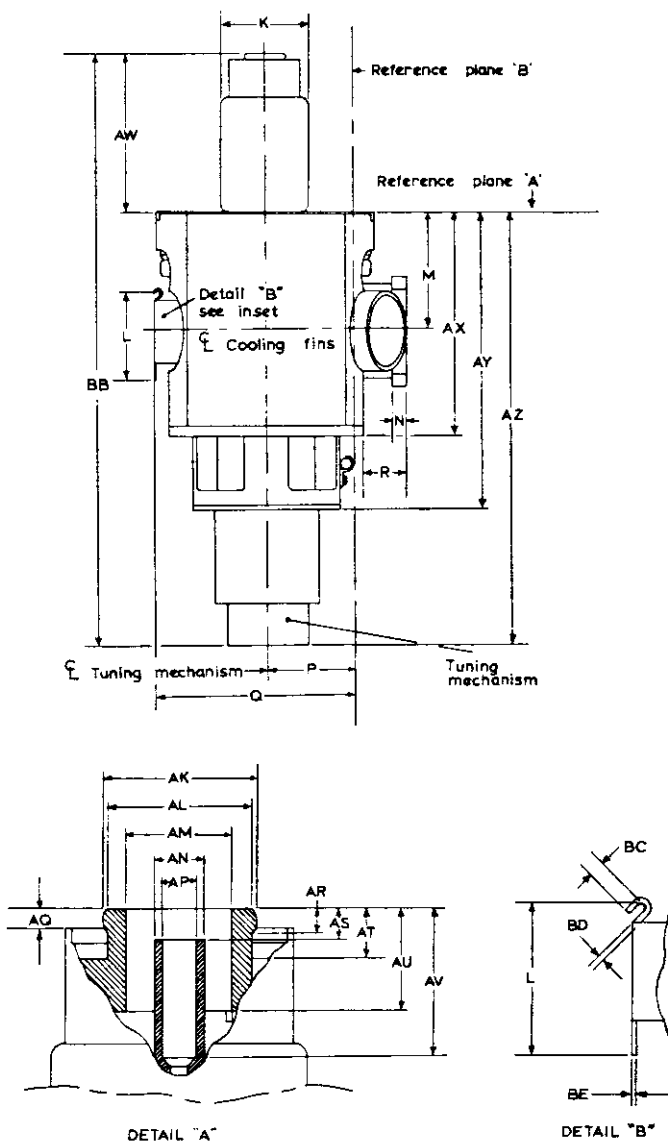

DIMENSIONS OF YJ1180 AND YJ1181

	Millimetres	Inches	Millimetres	Inches
A	46.5	1.83	AD	32 dia. 1.26 dia.
B	37.4 ± 0.1	1.47 ± 0.004	AE	18.5 0.73
C	12.6	0.49	AF	27° 27°
D	14.75 ± 1.2	0.58 ± 0.05	AG	47.5 1.87
E	46.5	1.83	AH	32 dia. 1.26 dia.
F	34.3 ± 0.1	1.35 ± 0.004	AJ	7.15 dia. 0.28 dia.
G	28.5	1.12	AK	21.1 ± 0.15 dia. 0.83 ± 0.006 dia.
H	47.1 ± 1.2	1.85 ± 0.05	AL	19 dia. 0.75 dia.
J	31.75 ± 2.0	1.25 ± 0.08	AM	13.7 ± 0.15 dia. 0.54 ± 0.006 dia.
K	38.1 dia.	1.50 dia.	AN	6.35 ± 0.4 dia. 0.25 ± 0.02 dia.
L	38	1.50	AP	4.3 ± 0.12 dia. 0.17 ± 0.005 dia.
M	47.1 ± 3.0	1.85 ± 0.12	AQ	0 min. 0 min.
N	6.5	0.26	AR	3.2 ± 0.25 0.13 ± 0.01
P	38.1 ± 2.0	1.50 ± 0.08	AS	3.95 ± 0.8 0.16 ± 0.03
Q	85.5 ± 3.0	3.37 ± 0.12	AT	6.35 0.25
R	23 ± 0.8	0.91 ± 0.03	AU	13.1 min. 0.51 min.
S	75 max.	2.95 max.	AV	19 min. 0.75 min.
T	138.5 max.	5.45 max.	AW	67.5 ± 2.4 2.66 ± 0.09
U	88.1 max.	3.47 max.	AX	96 max. 3.78 max.
V	63.5 ± 0.25	2.50 ± 0.01	AY	127 max. 5.00 max.
W	31.75 ± 1.2	1.25 ± 0.05	AZ	185 max. 7.28 max.
X	75 max.	2.95 max.	BB	255 max. 10.0 max.
Y	38.1 ± 1.2	1.50 ± 0.05	BC	4.0 0.16
Z	73 max.	2.87 max.	BD	1.6 0.06
AA	76.2 ± 0.25	3.00 ± 0.01	BE	1.0 0.04
AB	86.9 max.	3.42 max.	BF	10.7 max. 0.42 max.
AC	98.4 max.	3.87 max.	BG	22.5 0.89

Inch dimensions derived from original millimetre dimensions

B7248

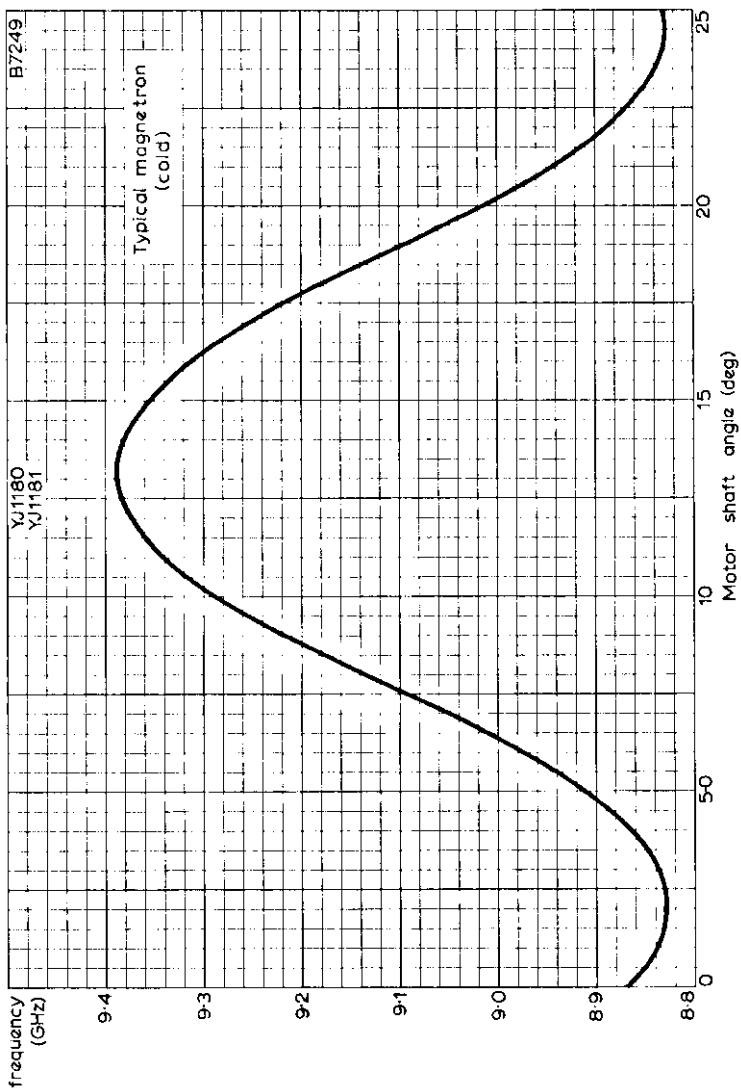

PASSIVE RESONANCE FREQUENCY AS A FUNCTION OF THE MOTOR SHAFT ANGLE

TENTATIVE DATA

QUICK REFERENCE DATA

High altitude magnetrons for X-band operation. Output coupling to type YJ1200 is WG16, and to type YJ1201 is WG15.

Frequency	9.375	GHz
Power output	50	kW
Construction	Packaged with flying leads	

Unless otherwise shown, data is applicable to both types

To be read in conjunction with

GENERAL OPERATIONAL RECOMMENDATIONS - MICROWAVE DEVICES

OPERATING CONDITIONS

R. F. pulse power output	50	kW
Duty factor	0.0016	
Pulse duration	4.0	μ s
Pulse repetition frequency	400	p.p.s.
Heater voltage (running)	7.7	V
Pulse current	12	A
Pulse voltage	12	kV
Pulse input power	144	kW
Rate of rise of voltage pulse	60	kV/ μ s
Mean input current	19.2	mA
Mean input power	230	W
Mean r.f. output power	80	W
Frequency pulling (v.s.w.r. \approx 1.3)	10	MHz

CATHODE

Indirectly heated

V_h	12.4	V
I_h	2.2 \pm 0.2	A
$I_{h(\text{surge})}$ max. starting	10	A

The cathode must be heated for at least 90 seconds before the application of h.t.

CHARACTERISTICS

	Min.	Max.	
Frequency fixed within the band	9.345	9.405	GHz
Pulse voltage ($I_{\text{pulse}} = 12\text{A}$)	11	12.5	kV
R. F. pulse power output ($I_{\text{pulse}} = 12\text{A}$)	40	-	kW
Frequency pulling (v. s. w. r. = 1.3)	-	15	MHz
Frequency temperature coefficient	-	-0.25	MHz/degC
Frequency pushing	-	0.5	MHz/A

RATINGS (ABSOLUTE MAXIMUM SYSTEM)

	Min.	Max.	
Pulse current	8.0	14	A
Pulse duration	-	5.0	μs
Duty factor	-	0.0025	
Mean input power	-	350	W
Rate of rise of voltage pulse	-	80	kV/ μs
Load mismatch (v. s. w. r.)	-	1.5	

END OF LIFE PERFORMANCE

The magnetron is deemed to have reached end of life when it fails to satisfy the following:-

R. F. pulse power output ($I_{\text{pulse}} = 12\text{A}$)

Min.	Max.	
	35	kW

	Min.	Max.	
Frequency fixed within the band	9.345	9.405	GHz

	Min.	Max.	
Pulse voltage ($I_{\text{pulse}} = 12\text{A}$)	11	13.5	kV

MOUNTING POSITION

Any

COOLING

Temperatures

Anode block max.	120	$^{\circ}\text{C}$
Cathode and heater seals max.	150	$^{\circ}\text{C}$

PRESSURISING

The magnetron is capable of unpressurised operation at altitudes up to 30 000ft for the YJ1200 and 40 000ft for the YJ1201.

PHYSICAL DATA

Weight of magnetron	1.9	kg
---------------------	-----	----



OUTLINE DRAWING OF YJ1200

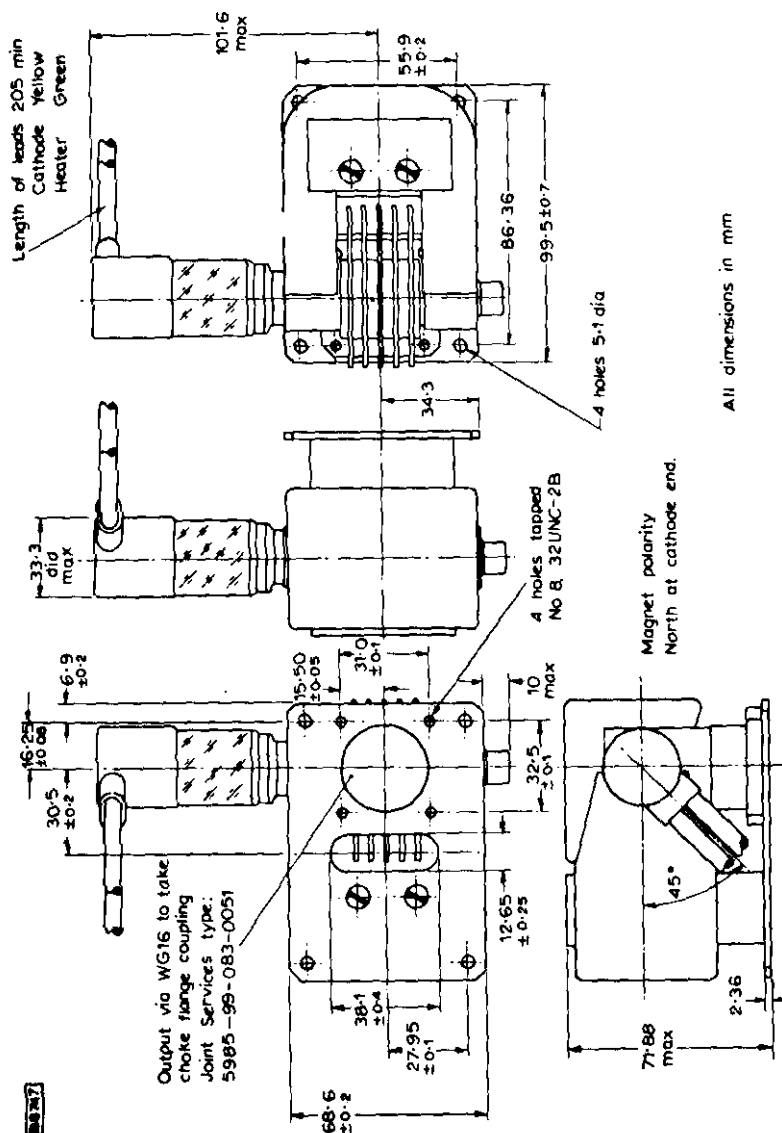

All dimensions in mm

OUTLINE DRAWING OF YJ1201

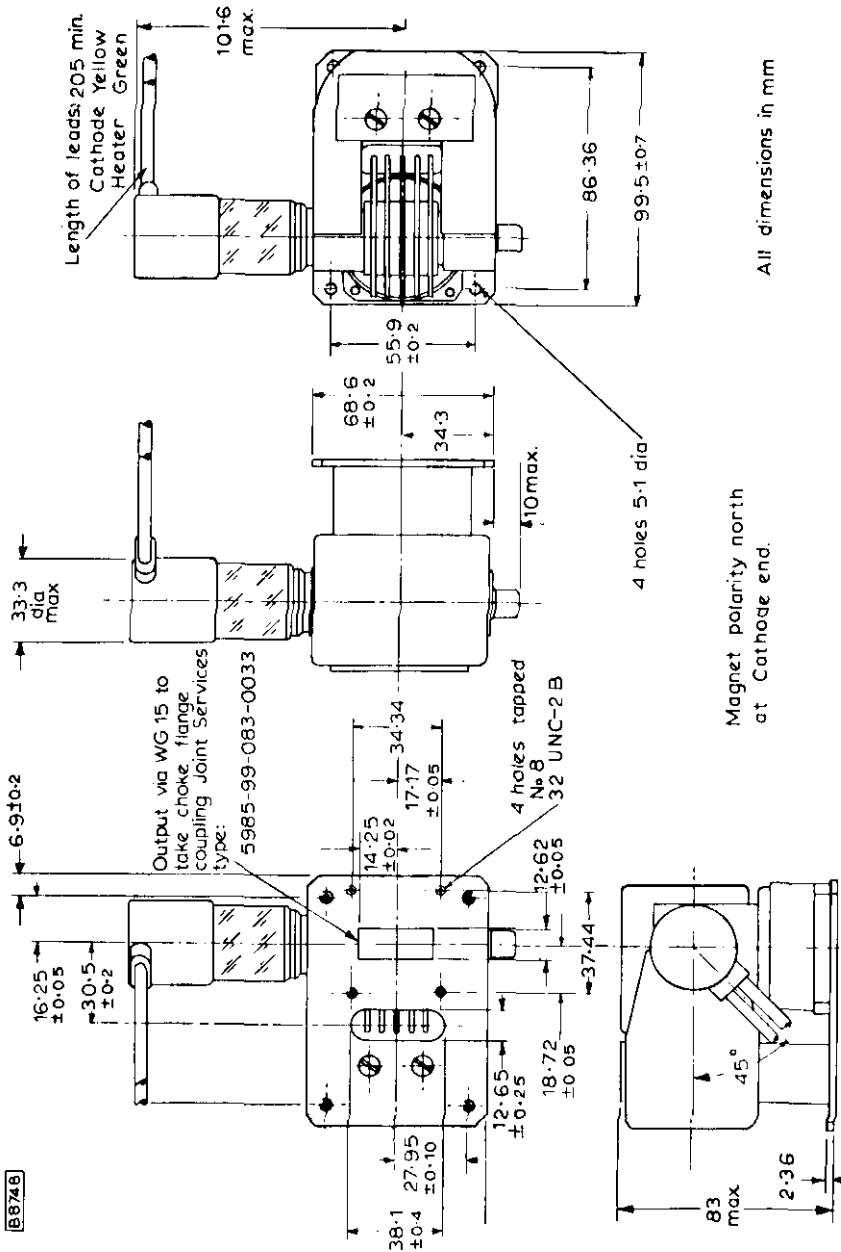

All dimensions in mm

Magnet polarity north at Cathode end.

88748



TENTATIVE DATA

QUICK REFERENCE DATA

X-Band fixed frequency rugged magnetron with quick warm-up cathode.
Suitable for airborne and missile requirements.

Magnetrons can be supplied to any spot frequency ± 50 MHz in X-Band.

f (nom)	9.375	GHz
P _{out}	150	W
Construction	Packaged, flying leads	

To be read in conjunction with
GENERAL OPERATIONAL RECOMMENDATIONS - MICROWAVE DEVICES

OPERATING CONDITIONS

R. F. Pulse power output	150	W
Duty factor	0.01	
Pulse duration	0.2	μ s
Pulse repetition frequency	50	kHz
Heater voltage	5.0	V
Pulse current	1.0	A
Pulse voltage	850	V
Rate of rise of voltage pulse	30	kV/ μ s
Frequency pulling (v. s. w. r. = 1.5)	15	MHz

CATHODE

Indirectly heated

V _h	5.0	V
I _h	0.7	A
*t _{h-k} typ	2.5	s

*Heater and h. t. voltage applied simultaneously

PHYSICAL DATA

Weight of magnetron	170	g
---------------------	-----	---



CHARACTERISTICS

Frequency (nom)		9.375	MHz
	Min.	Max.	
Pulse voltage ($I_{\text{pulse}} = 1.0\text{A}$)	800	900	V
R. F. Pulse power output ($I_{\text{pulse}} = 1.0\text{A}$)	120	-	W
Frequency pulling (v.s.w.r. = 1.5)	-	18	MHz
Frequency temperature coefficient	-	-0.25	MHz per degC

RATINGS (ABSOLUTE MAXIMUM SYSTEM)

	Min.	Max.	
Pulse current	0.5	2.0	A
Pulse duration	0.03	1.0	μs
Duty factor	-	0.02	
Mean input power	-	25	W
Rate of rise of voltage pulse	-	50	kV/ μs
Load mismatch (v.s.w.r.)	-	1.5	

END OF LIFE PERFORMANCE

The magnetron is deemed to have reached end of life when it fails to satisfy the following:-

R. F. Pulse power output ($I_{\text{pulse}} = 1.0\text{A}$)		90	W
	Min.	Max.	
Pulse voltage ($I_{\text{pulse}} = 1.0\text{A}$)	750	900	V

MOUNTING POSITION

Any

COOLING

Temperature

Anode block max		140	$^{\circ}\text{C}$
-----------------	--	-----	--------------------



OUTLINE DRAWING OF YJ1220

87778

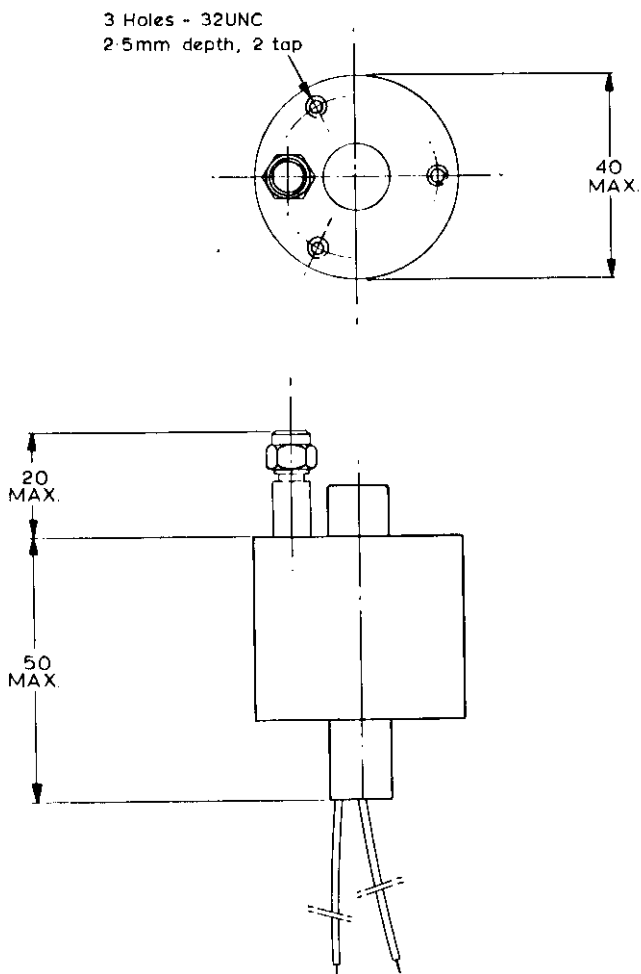

All dimensions in mm.

TENTATIVE DATA

QUICK REFERENCE DATA		
X-Band fixed frequency rugged magnetron		
Frequency	9.345	GHz
Power output (pk)	90	kW
Construction	Lightweight, packaged with flying leads	

To be read in conjunction with

GENERAL OPERATIONAL RECOMMENDATIONS-MICROWAVE DEVICES

OPERATING CONDITIONS

R. F. Pulse power output	90	kW
Duty factor	0.0012	
Pulse duration	6.0	μ s
Pulse repetition frequency	200	p. p. s.
Heater voltage (running)	7.7	V
Pulse current	17.5	A
Pulse voltage	15.2	kV
Pulse input power	265	kW
Rate of rise of voltage pulse	50	kV/ μ s
Mean input current	21	mA
Mean input power	320	W
Mean r. f. output power	108	W
Frequency pulling (v. s. w. r. = 1.3)	10	MHz

CATHODE

Indirectly heated

V_h	12.6	V
I_h	2.0 to 2.4	A
$I_{h(\text{surge})}$ max.	10	A
r_h (cold)	0.65	Ω

The cathode must be heated for at least 90 seconds before the application of h. t.

CHARACTERISTICS

	Min.	Max.	
Frequency fixed within the band	9.315	9.375	GHz
Pulse voltage ($I_{\text{pulse}} = 17.5\text{A}$)	14	16	kV
R.F. Pulse power output ($I_{\text{pulse}} = 17.5\text{A}$)	85	120	kW
Frequency pulling (v.s.w.r. = 1.3)	-	15	MHz
Frequency temperature coefficient	-	-0.25	MHz per degC
Input capacitance	-	14	pF
Frequency pushing	-	0.5	MHz per A

RATINGS (ABSOLUTE MAXIMUM SYSTEM)

	Min.	Max.	
Pulse current	15	20	A
Pulse duration	-	7.0	μs
Duty factor	-	0.0015	
Mean input power	-	400	W
Rate of rise of voltage pulse	-	90	kV/ μs
Load mismatch (v.s.w.r.)	-	1.5	

END OF LIFE PERFORMANCE

The magnetron is deemed to have reached end of life when it fails to satisfy the following:-

R.F. Pulse power output ($I_{\text{pulse}} = 17.5\text{A}$)		75	kW
	Min.	Max.	
Frequency fixed within the band	9.315	9.375	GHz
Pulse voltage ($I_{\text{pulse}} = 17.5\text{A}$)	14	17	kV

MOUNTING POSITION

Any

PHYSICAL DATA

Weight of magnetron		1.9	kg
---------------------	--	-----	----

COOLING

Temperatures

Anode block max.	120	°C
Cathode and heater seals max.	150	°C

PRESSURISING

The cathode stem bushing will not arc over at a reduced atmospheric pressure equivalent to an altitude of 35 000ft. The output system will operate satisfactorily at a reduced atmospheric pressure equivalent to an altitude of 25 000ft with a load v.s.w.r. of 1.5:1 varied through all phases.

VIBRATION

The magnetron will operate normally when subjected to sinusoidal vibrations of amplitude +0.5mm or 1.5g which ever is the smaller in the frequency range 5 to 150Hz in any plane and the total frequency deviation shall not exceed 100kHz.

ACCELERATION

The magnetron will function normally when subjected to an acceleration of 5.5g in any plane. No part of the valve will break loose when subjected to an acceleration of 10g in any plane.

CLIMATIC

The magnetron will meet the requirements of the Joint Services Spec. K1001 issue 6 clauses 10.1, 10.3 and 10.8.

OUTLINE DRAWING OF YJ1250

B8197

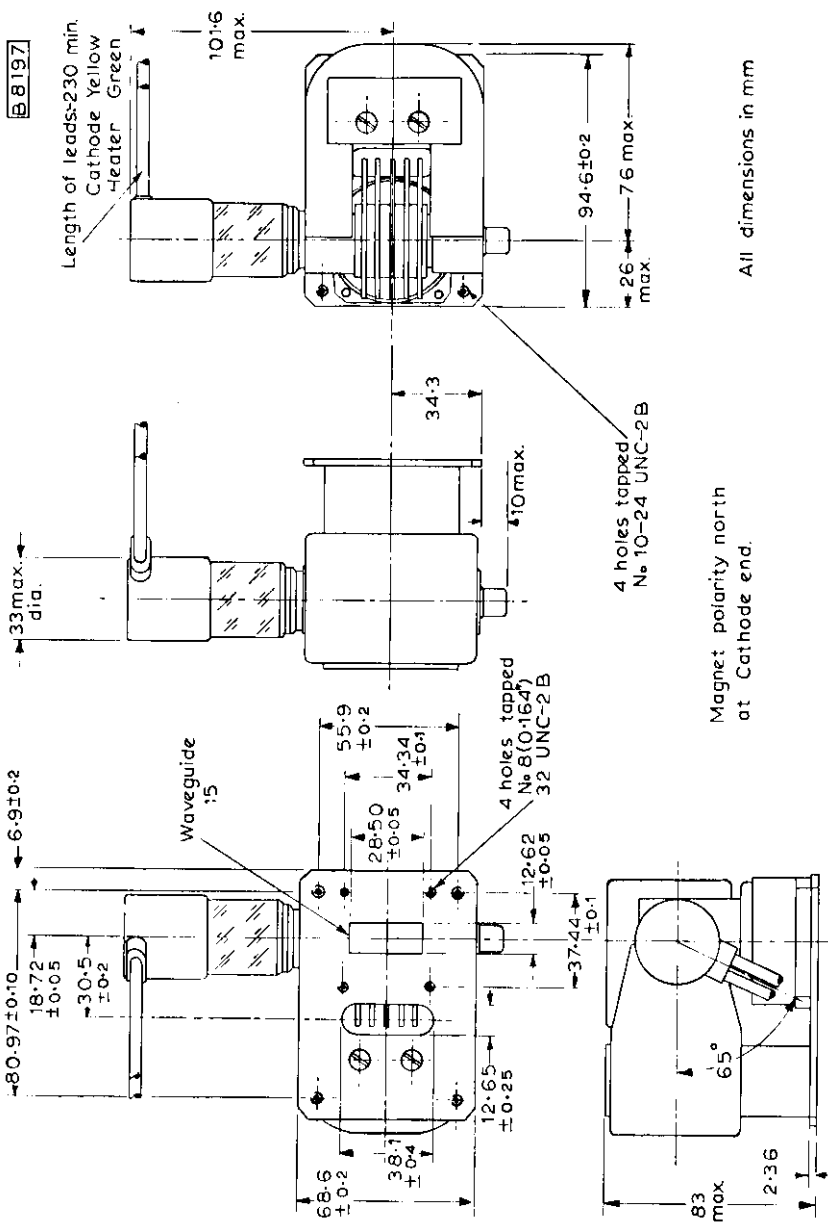

All dimensions in mm

Magnet polarity north at Cathode end.



TENTATIVE DATA

QUICK REFERENCE DATA

X-band, fixed frequency, pulsed magnetron

Frequency (fixed within the band)	9.415 to 9.475	GHz
Power output (peak)	65	kW
Construction		Packaged
Output connection		Waveguide 16 flange

To be read in conjunction with

GENERAL OPERATIONAL RECOMMENDATIONS - MICROWAVE DEVICES

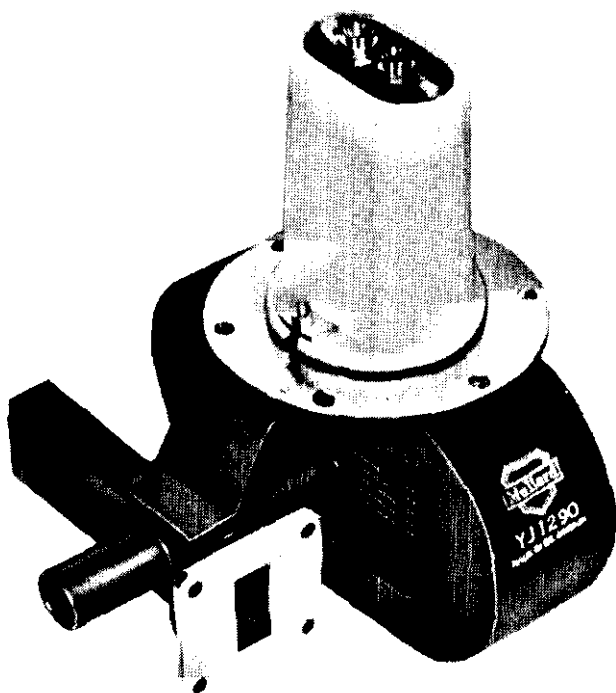

TYPICAL OPERATION

Operating conditions

Heater voltage	1.0	V
Anode current (peak)	14	A
Pulse duration (t_p)	0.5	μ s
Pulse repetition rate	1250	pulse/s
Rate of rise of voltage pulse	145	kV/ μ s

Typical performance

Anode voltage	14	kV
Power output (peak)	65	kW
Power output (mean)	40.5	W

CATHODE

Indirectly heated

Heater voltage (see notes 1 and 9)	6.3	V
Heater current	1.0	A
Heater current (surge) max.	5.0	A
Heating time min. (see note 2)	2.0	minutes

TEST CONDITIONS AND LIMITS

The magnetron is tested to comply with the following electrical specifications:-

Test conditions

Heater voltage (for test)	0	V
Anode current (mean)	8.8	mA
Duty factor	0.00062	
Pulse duration (t_p) see note 3	0.5	μ s
v.s.w.r. at output connection	\dagger 1.05:1	
Rate of rise of voltage pulse (see note 4)	\dagger 150	kV/ μ s

Limits and characteristics

	Min.	Max.	
Anode voltage (peak)	12.5	15	kV
Power output (mean)	34	-	W
Frequency	9.415	9.475	GHz
R. F. Bandwidth at 1/4 power (see note 3)	-	$\frac{2.5}{tp}$	
Frequency pulling (v.s.w.r. = 1.5:1)	-	15	MHz
Minor lobe level (v.s.w.r. = 1.5:1)	6.0	-	dB
Stability (see note 5)	-	0.25	%
Heater current (see note 6)			
Frequency temperature coefficient (see note 7)			



RATINGS (ABSOLUTE MAXIMUM SYSTEM)

These ratings cannot necessarily be used simultaneously and no individual rating should be exceeded.

	Min.	Max.	
Heater voltage	5.7	7.0	V
Anode voltage (peak)	-	16	kV
Anode current (peak)	12	16	A
Power input (mean)	-	160	W
Duty factor	-	0.001	
Pulse duration (t_p) (see note 3)	-	1.0	μ s
Rate of rise of voltage pulse (see note 4)	100	150	kV/ μ s
Anode temperature (see note 8)	-	120	$^{\circ}$ C
v.s.w.r. at output connection	-	1.5:1	

END OF LIFE PERFORMANCE

The quality of all production is monitored by random selection of magnetrons which are then life tested under the stated test conditions. If the magnetron is to be operated under different conditions from those specified above, Mullard Ltd. should be consulted to verify that the life will not be affected. The magnetron is considered to have reached the end of life when it fails to meet the following limits when tested as specified on page 2.

	Min.	Max.	
Power output (peak)	50	-	kW
Frequency	9.415	9.475	GHz
R.F. bandwidth at 1/4 power	-	$\frac{3.5}{t_p}$	MHz
Stability	-	0.5	%

MOUNTING POSITION (see note 10)

Any

COOLING

Adequate cooling is provided at maximum mean input power by an airflow of $0.43\text{m}^3/\text{min}$ ($15\text{ft}^3/\text{min}$) at $T_{\text{amb}} = 55^{\circ}\text{C}$ and standard pressure from an orifice of 31.75mm (1.250in) diameter located at 6.35mm (0.250in) from the cooling fins.

PHYSICAL DATA

	kg	lb	
Weight of magnetron	2.1	4.6	
Weight of magnetron in storage carton	2.75	6.0	
Dimensions of storage carton	215.9 × 247.65 × 266.7		mm
	8.5 × 9.75 × 10.5		in.

VIBRATION

The magnetron is vibration tested to ensure that it will withstand normal conditions of service.

NOTES

1. With no anode input power. The heater voltage during operation is very dependant on the application and should be agreed with Mullard Ltd.
2. For ambient temperatures above -15°C the cathode must be heated for at least 2 minutes before the application of H.T. For ambient temperatures between -15°C and -55°C the cathode heating time is 3 minutes minimum.
3. The tolerance of pulse current duration (t_p) measured at 50% amplitude is $\pm 10\%$.
4. Defined as the steepest tangent to the leading edge of the anode voltage pulse above 80% amplitude.
5. With the magnetron operating into a v.s.w.r. of 1.5:1 varied through all phases over the anode current range of 12A to 16A peak. Pulses are defined as missing when the r.f. energy level is $< 70\%$ of the normal level in the frequency range 9.415GHz to 9.475GHz. Missing pulses are expressed as a percentage of the number of input pulses applied during the period of observation after a period of 3 minutes of operation.
6. Measured with a heater voltage of 6.3V and no anode input power, the heater current limits are 0.9 and 1.1A.
7. Design test only. The maximum frequency change with anode temperature change, after warming, is -0.25MHz/degC .
8. The anode temperature measured at the point indicated on the outline drawing must be kept below the limit specified.
9. The magnetron is normally tested with a heater supply of 50Hz and is suitable for operation at 1.1kHz. Mullard Ltd. should be consulted if the magnetron is to be operated with a heater supply of any other frequency.
10. It is necessary to keep all magnetic material as far as possible, at least 50mm (2in.) away from the magnet. The inner polystyrene pack of the magnetron carton provides adequate separation between magnetrons, and it is recommended that magnetrons not in use be kept in these packs.

OUTLINE DRAWING

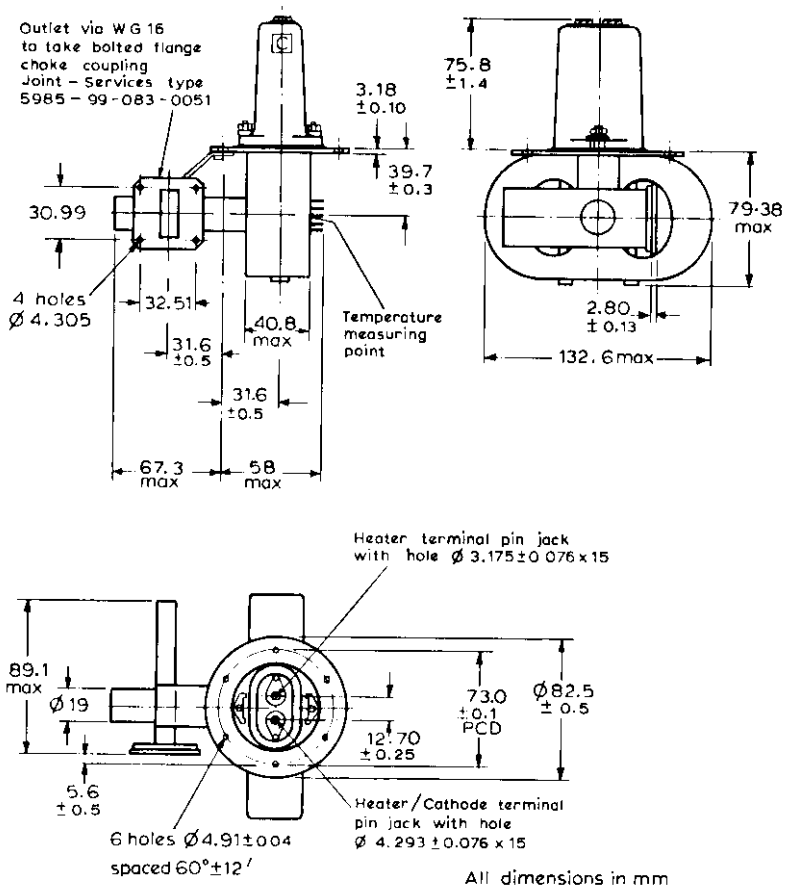

Millimetre to inch conversion table overleaf

Millimetre to inch conversion table (rounded outwards).

Millimetres	Inches
2.80 ± 0.13	0.110 ± 0.005
∅ 3.175 ± 0.076 × 15	∅ 0.125 ± 0.003 × 0.591
3.18 ± 0.10	0.1252 ± 0.0040
∅ 4.293 ± 0.076 × 15	∅ 0.169 ± 0.003 × 0.591
∅ 4.305	∅ 0.1695
∅ 4.91 ± 0.04	∅ 0.1932 ± 0.0015
5.6 ± 0.5	0.220 ± 0.020
12.70 ± 0.25	0.500 ± 0.010
∅ 19	∅ 0.75
30.99	1.220
31.6 ± 0.5	1.244 ± 0.020
32.51	1.280
39.7 ± 0.3	1.563 ± 0.012
40.8 max	1.606 max
58 max	2.28 max
67.3 max	2.650 max
73.0 ± 0.1	2.874 ± 0.004
75.8 ± 1.4	2.984 ± 0.055
79.38 max	3.125 max
82.5 ± 0.5	3.248 ± 0.020
89.1 max	3.51 max
132.6 max.	5.22 max

QUICK REFERENCE DATA

X-Band, fixed frequency, pulsed magnetron.

Frequency (fixed within the band) 9.380 to 9.140 GHz

Power output (peak) 7.0 kW

Construction Packaged

Output connection Waveguide 16 flange

To be read in conjunction with
GENERAL OPERATIONAL RECOMMENDATIONS - MICROWAVE DEVICES

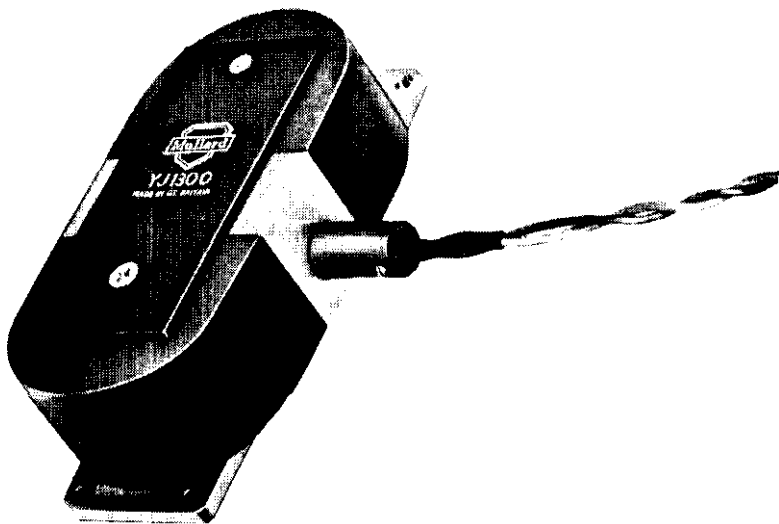

TYPICAL OPERATION

Operating conditions	Condition 1	Condition 2	
Heater voltage	6.3	6.3	V
Anode current (peak)	5.0	5.0	A
Pulse duration (tp)	0.1	1.0	μ s
Pulse repetition rate	2000	1000	pulse/s
Rate of rise of voltage pulse	60	60	kV/ μ s

Typical performance

Anode voltage (peak)	4.25	4.25	kV
Power output (peak)	7.0	7.0	kW
Power output (mean)	1.4	7.0	W

CATHODE

Indirectly heated

Heater voltage	6.3	V
Heater current	0.5	A
Heater current (surge) maximum	3.0	A
Heating time (minimum) (see note 1)	30	s

TEST CONDITIONS AND LIMITS

The magnetron is tested to comply with the following electrical specification.

Test conditions

Heater voltage	6.3	V
Anode current (mean)	5.0	mA
Duty factor	0.001	
Pulse duration (tp) (see note 2)	1.0	μ s
v.s.w.r. at output connection	1.05:1	
Rate of rise of voltage pulse (see note 3)	75	kV/ μ s

TEST CONDITIONS AND LIMITS (contd.)

Limits and characteristics

	Min.	Max.	
Anode voltage (peak)	4.0	4.5	kV
Power output (mean)	6.0	-	W
Frequency (see note 4)	9.380	9.440	GHz
R. F. Bandwidth at 1/4 power (see note 2)	-	$\frac{2.5}{tp}$	MHz
Frequency pulling (v.s.w.r. = 1.5:1)	-	18	MHz
Stability (see note 5)	-	0.25	%
Minor lobe level	6.0	-	dB
Cold impedance (see note 6)			
Heater current (see note 7)			
Frequency temperature coefficient (see note 8)			
Input capacitance (see note 9)			

RATINGS (ABSOLUTE MAXIMUM SYSTEM)

These ratings cannot necessarily be used simultaneously and no individual rating should be exceeded.

	Min.	Max.	
Heater voltage (see note 10)	5.7	6.9	V
Anode voltage (peak)	4.0	4.6	kV
Anode current (peak)	4.0	6.0	A
Power input (peak)	-	20	kW
Power input (mean)	-	20	W
Duty factor	-	0.001	
Pulse duration (tp)	-	1.0	μ s
Rate of rise of voltage pulse (see note 3)	-	75	kV/ μ s
Anode temperature	-	120	$^{\circ}$ C
v.s.w.r. at output connection	-	1.5:1	



END OF LIFE PERFORMANCE

The quality of all production is monitored by the random selection of magnetrons which are then life tested under the stated test conditions. If the magnetron is to be operated under different conditions from those specified above, Mullard Ltd., should be consulted to verify that the life will not be affected. The magnetron is considered to have reached the end of life when it fails to meet the following limits when operated under the conditions specified on page 2.

	Min.	Max.	
Anode voltage (peak)	4.0	4.5	kV
Power output (mean)	5.0	-	kW
Frequency	9.380	9.440	GHz

MOUNTING POSITION (see note 11)

Any

COOLING

Natural

PHYSICAL DATA

	kg	lb
Weight of magnetron	1.25	2.75
Weight of magnetron in storage carton	1.82	4.0
	mm	in
Dimensions of storage carton	190 × 190 × 280	7.5 × 7.5 × 11

VIBRATION

The magnetron is vibration tested to ensure that it will withstand normal conditions of service.

NOTES

1. For ambient temperatures above 0°C the cathode must be heated for at least 30 seconds before the application of h.t. For ambient temperatures between 0°C and -55°C the cathode heating time is 45 seconds minimum.
2. The tolerance of pulse current duration (tp) is ±10%.
3. Defined as the steepest tangent to the leading edge of the voltage pulse above 80% amplitude.
4. Magnetrons with other frequency ranges can be supplied to order.
5. With the magnetron operating into a v.s.w.r. of 1.5:1 varied through all phases over an anode current range of 4.0mA to 6.0mA. Pulses are defined as missing when the energy level is less than 70% of the normal level in the frequency range 9.380 to 9.440GHz. Missing pulses are expressed as a percentage of the number of input pulses applied during the period of observation after a period of 10 minutes operation.
6. The cold impedance is measured at the operating frequency and will give a v.s.w.r. of >6:1. The position of voltage minimum from the face of the output flange into the magnetron shall be 3.0 to 9.0mm.



NOTES (contd.)

7. Measured with heater voltage of 6.3 volts and no anode input power, the heater current limits are 0.5 to 0.6A.
8. Design test only. The maximum frequency change with anode temperature change (after warming) is -0.25MHz/degC .
9. Design test only. The maximum input capacitance is 9.0pF.
10. The magnetron is normally tested with a heater supply of 50Hz and is suitable for operation at 1kHz. Mullard Ltd. should be consulted if the magnetron is to be operated with a heater supply of any other frequency.
11. It is necessary to keep all magnetic material as far as possible, at least 50mm (2in) from the magnet. The inner polystyrene pack of the magnetron carton provides adequate separation between magnetrons and it is recommended that magnetrons not in use be kept in these packs.



OUTLINE DRAWING OF YJ1300

B9800

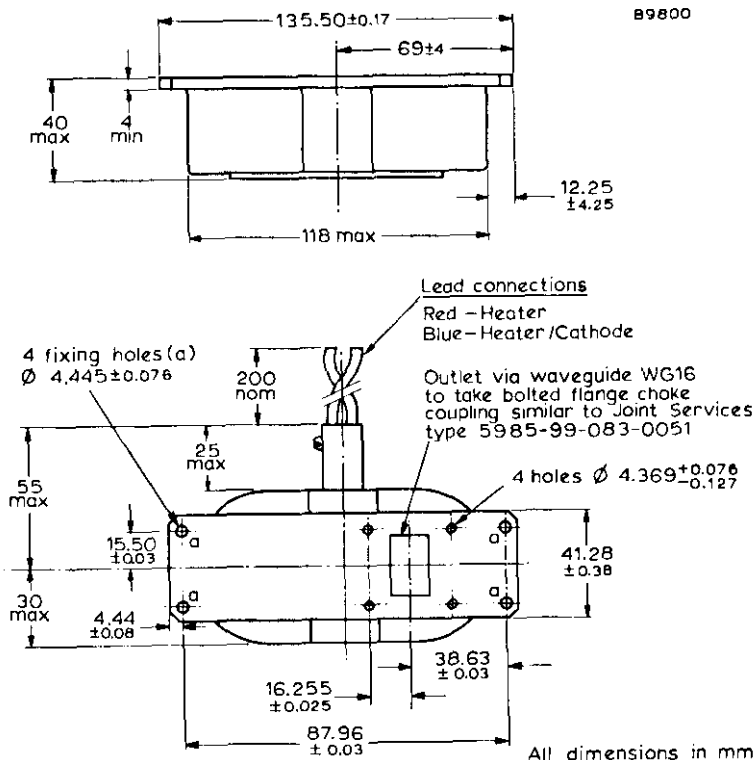

CONVERSION TABLE
(Rounded outwards)

Millimetres	Inches	Millimetres	Inches
4 min.	0.15 min.	38.63 ± 0.03	1.5209 ± 0.0012
$\varnothing 4.369^{+0.076}_{-0.127}$	$\varnothing 0.172^{+0.003}_{-0.005}$	40 max.	1.58 max.
4.44 ± 0.08	0.1748 ± 0.0032	41.28 ± 0.38	1.625 ± 0.015
$\varnothing 4.445 \pm 0.076$	$\varnothing 0.175 \pm 0.003$	55 max.	2.17 max.
12.25 ± 4.25	0.48 ± 0.17	69 ± 4	2.72 ± 0.16
15.50 ± 0.03	0.6102 ± 0.0012	87.96 ± 0.03	3.4630 ± 0.0012
16.255 ± 0.025	0.640 ± 0.001	118 max.	4.65 max.
25 max.	0.99 max.	135.50 ± 0.17	5.3347 ± 0.0067
30 max.	1.19 max.	200 nom.	7.87 nom.



QUICK REFERENCE DATA

Fixed frequency 'X' band magnetron with natural or forced-air cooling.

Frequency	9,345 to 9,405	Gc/s
Power output (pulsed)	7.5	kW

To be read in conjunction with GENERAL OPERATIONAL RECOMMENDATIONS - MICROWAVE DEVICES.

CHARACTERISTICS

	Min.	Max.	
Frequency			
Fixed within the band	9,345	9,405	Gc/s
Pulse voltage (I _{pulse} = 4.5A)	5.3	5.7	kV
R. F. pulse power output (I _{pulse} = 4.5A)	7.0	-	kW
Frequency pulling (v. s. w. r. = 1.5)	-	15	Mc/s
Frequency temperature coefficient	-	0.25	Mc/s per °C
Distance of v. s. w. minimum from face of mounting plate into valve	13.5	22.5	mm
Input capacitance	-	8.0	pF

TYPICAL OPERATION

R. F. pulse power output	7.5	kW
Duty factor	0.001	
Pulse duration	1.0	μs
Pulse repetition frequency	1000	p. p. s.
Heater voltage (running)	6.3	V
Pulse current	4.5	A
Pulse voltage	5.5	kV
Pulse input power	24.7	kW
Rate of rise of voltage pulse	50	kV/μs
Mean input current	4.5	mA
Mean input power	24.7	W
Mean r. f. output power	7.5	W
Frequency pulling (v. s. w. r. = 1.5)	14	Mc/s

CATHODE

Indirectly heated

V _h	6.3	V
I _h	600	mA

Heating time. At ambient temperatures above 0 °C the cathode must be heated for at least 2 minutes before the application of h.t. Below this temperature the heating time must be increased to at least 3 minutes.

For mean input powers greater than 25 watts, it is necessary to reduce the heater voltage within 3 seconds of applying h.t. in accordance with the formula:

$$V_h = 6.3 \left(1 - \frac{P_{in}}{180} \right) \text{Volts}$$

ABSOLUTE MAXIMUM RATINGS

	Min.	Max.	
Pulse current	3.5	5.5	A
Pulse duration		2.5	μs
Duty factor		0.0025	
Mean input power		82.5	W
Rate of rise of voltage pulse		75	kV/μs
Load mismatch (v. s. w. r.)		1.5	
Temperature of anode block		120	°C

MOUNTING POSITION

Any

PHYSICAL DATA

	lb	kg
Weight of magnetron	3.0	1.4
Weight of magnetron in carton	5.7	2.5

	in	mm
Dimensions of storage carton	7.75 x 8.0 x 9.75	200 x 210 x 250

COOLING

In normal circumstances natural cooling is adequate, but where the ambient temperature is abnormally high, a flow of cooling air between the radiator fins may be necessary to keep the block temperature below the permitted maximum.

DIMENSIONS

	Inches			Millimetres		
	Min.	Nom.	Max.	Min.	Nom.	Max.
A	4.438	-	4.469	112.7	-	113.5
B	-	4.103	-	-	104.2	-
C	0.167	-	0.173	4.24	-	4.39 dia.
D	0.172	-	0.178	4.37	-	4.52 dia.
E	0.156	-	0.188	3.96	-	4.78
F	1.276	-	1.284	32.4	-	32.5
G	1.216	-	1.224	30.9	-	31.1
H	-	-	1.0	-	-	25.4
J	0.188	-	0.219	4.78	-	5.56
K	1.609	-	1.641	40.9	-	41.7
L	2.688	-	3.188	68.28	-	80.98
M	-	-	2.188	-	-	55.58
N	-	-	1.188	-	-	30.18
P	-	-	4.0	-	-	101.6
Q	1.938	-	-	49.22	-	-
R	-	-	3.313	-	-	84.15
S	0.750	-	1.0	19.05	-	25.40
T	-	-	0.375	-	-	9.52
U	-	-	0.250	-	-	6.35
V	-	1.250	-	-	31.75	-
W	-	0.125	-	-	3.175	-
X	-	2.393	-	-	60.78	-
Y	-	1.220	-	-	30.99	-

Millimetre dimensions derived from original inch dimensions.



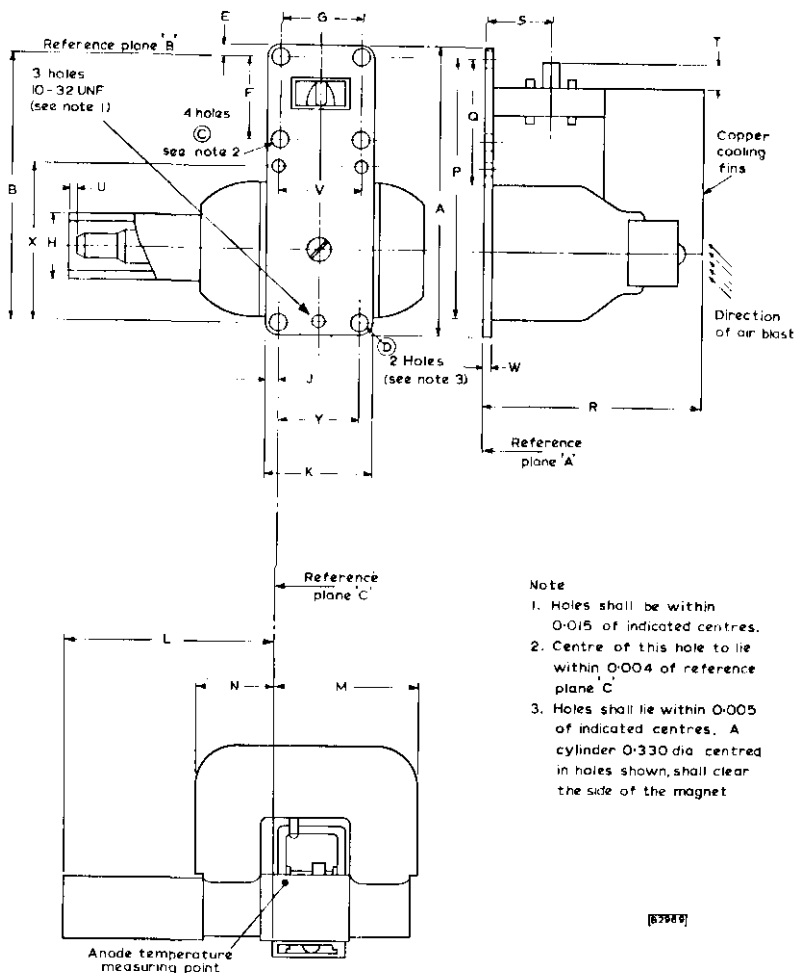

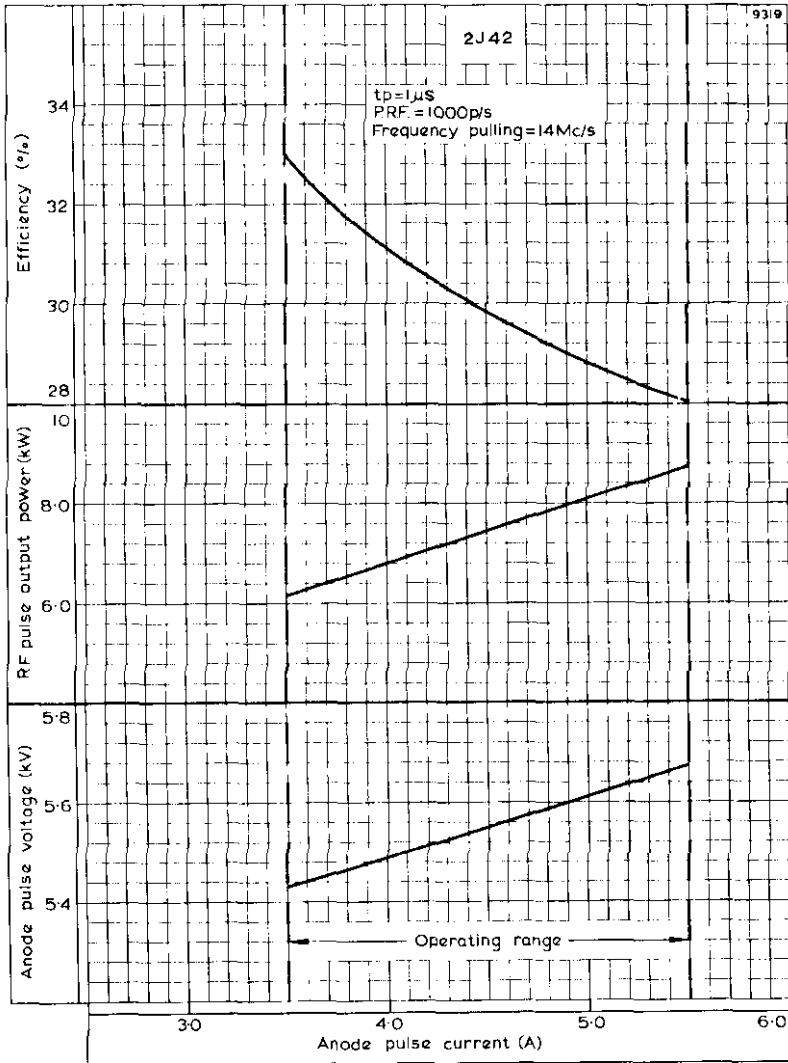

ANODE PULSE VOLTAGE, R.F. PULSE POWER OUTPUT AND EFFICIENCY PLOTTED AGAINST ANODE PULSE CURRENT

QUICK REFERENCE DATA

Fixed frequency 'X' band forced air cooled magnetron.

Frequency	9.375	GHz
Power output (pulsed)	50	kW
Construction		Packaged

To be read in conjunction with
GENERAL OPERATIONAL RECOMMENDATIONS - MICROWAVE DEVICES

OPERATING CONDITIONS

R. F. pulse power output	50	50	kW
Duty factor	0.00067	0.001	
Pulse duration	2.0	1.0	μ s
Pulse repetition frequency	325	1000	p.p.s.
Heater voltage (running)	2.5	0	V
Pulse current	12	12	A
Pulse voltage	12	12	kV
Pulse input power	144	144	kW
Rate of rise of voltage pulse	50	50	kV/ μ s
Mean input current	8.0	12	mA
Mean input power	96	144	W
Mean r.f. output power	32.5	50	W
Frequency pulling (v.s.w.r. = 1.5)	12	12	MHz

CATHODE

Indirectly heated

V_h	6.3 \pm 10%	V
I_h	1.0	A
I_h (surge) max.	6.0	A
t_{h-k} (min.)	120	s

It is necessary to reduce the heater voltage immediately after the application of h.t. in accordance with the input power-heater voltage rating chart on page C1.

CHARACTERISTICS

	Min.	Max.	
Frequency (fixed within the band)	9.345	9.405	GHz
Pulse voltage ($I_{\text{pulse}} = 12\text{A}$)	4.0	13.0	kV
R.F. pulse power output ($I_{\text{pulse}} = 12\text{A}$)	40	-	kW
Frequency pulling (v.s.w.r.= 1.5)	-	15.0	MHz
Frequency temperature coefficient	-	0.25	MHz per degC

RATINGS (ABSOLUTE MAXIMUM SYSTEM)

	Max.	
Pulse current	16	A
Pulse duration	2.5	μs
Duty factor	0.001	
Mean input power	180	W
Rate of rise of voltage pulse	60	kV/ μs
Load mismatch (v.s.w.r.)	1.5	

END OF LIFE PERFORMANCE

The valve is deemed to have reached end of life when it fails to satisfy the following:

R. F. pulse power output ($I_{\text{pulse}} = 12\text{A}$)	30	kW
Frequency	Min.	Max.

Within the band	9.345	to	9.405	GHz
-----------------	-------	----	-------	-----

BANDWIDTH

$\frac{3.0}{t_p}$ MHz

Where t_p = Pulse duration in μs

MOUNTING POSITION

Any

PRESSURISING

The magnetron need not be pressurized at heights up to 10,000ft.

The circular mounting flange and the waveguide output system of the valve are made to enable the magnetron to be used in applications requiring a pressure seal.

They can be maintained at a pressure of 3.17kg/cm^2 (45lb/in^2) absolute.

PHYSICAL DATA

	kg	lb
Weight of magnetron	1.7	3.7
Weight of magnetron in carton	4.5	9.9

COOLING

A flow of cooling air may be necessary to keep the anode block temperature below the permitted maximum.

Temperature

Anode block max.	100	$^{\circ}\text{C}$
------------------	-----	--------------------

OUTLINE DRAWING

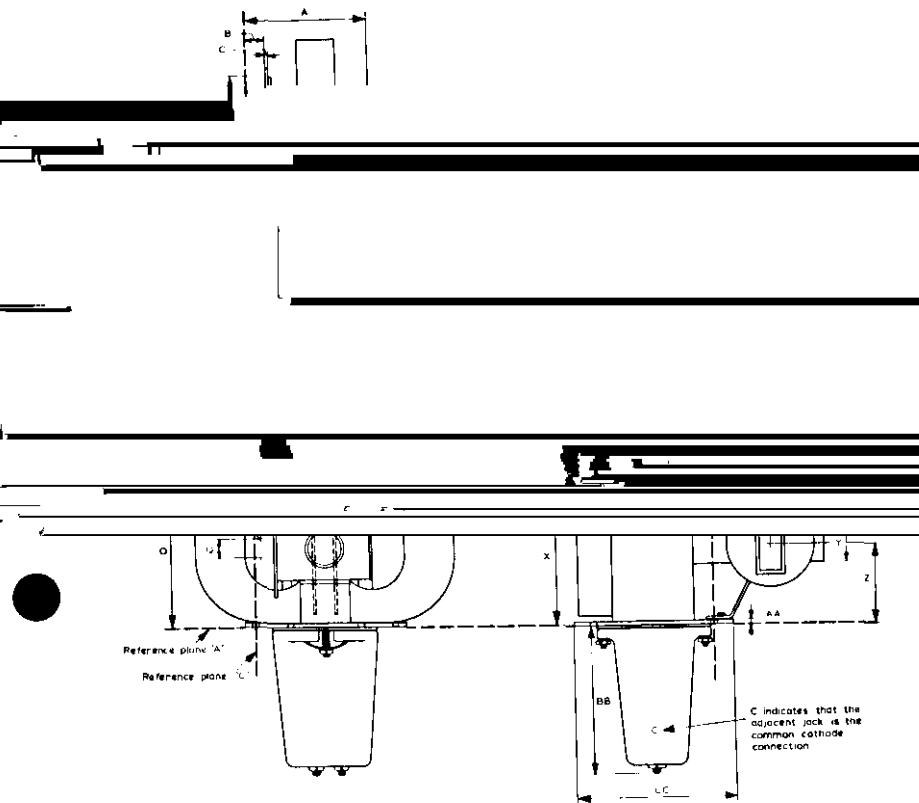

947B

ANODE CONNECTION TERMINATED AT THE BASE PLATE

Dimensions overleaf

DIMENSIONS

	Millimetres	Inches	
A	63.5	2.50	max.
B	11.1 ±0.5	0.437 ±0.020	
C	2.16 ±0.13	0.085 ±0.0051	
D	36	1.42	max.
E	31.6	1.24	
F	4.90 ±0.07	0.193 ±0.0028	dia.
G	30.15	1.187	
H	36.5 ±0.7	1.437 ±0.028	
J	42.85	1.687	
K	73.0 ±0.13	2.874 ±0.0051	
L	136.47	5.373	max.
M	12.7	0.5	max.
N	1.6	0.063	
O	79.3	3.12	max.
P	34	1.34	rad
Q	9.5	0.37	
R	69.7	2.74	max.
S	67.6	2.66	max.
T	44.45 ±0.18	1.750 ±0.0071	
U	52.3	2.06	max.
V	30.3 ±0.5	1.192 ±0.020	
W	11	0.43	min.
X	75.4	2.97	max.
Y	19	0.75	
Z	39.7 ±0.5	1.563 ±0.020	
AA	3.18 ±0.13	0.125 ±0.0051	
BB	75.8 ±1.6	2.984 ±0.063	
CC	82.5 ±0.7	3.248 ±0.028	

Millimetre dimensions derived from original inch dimensions

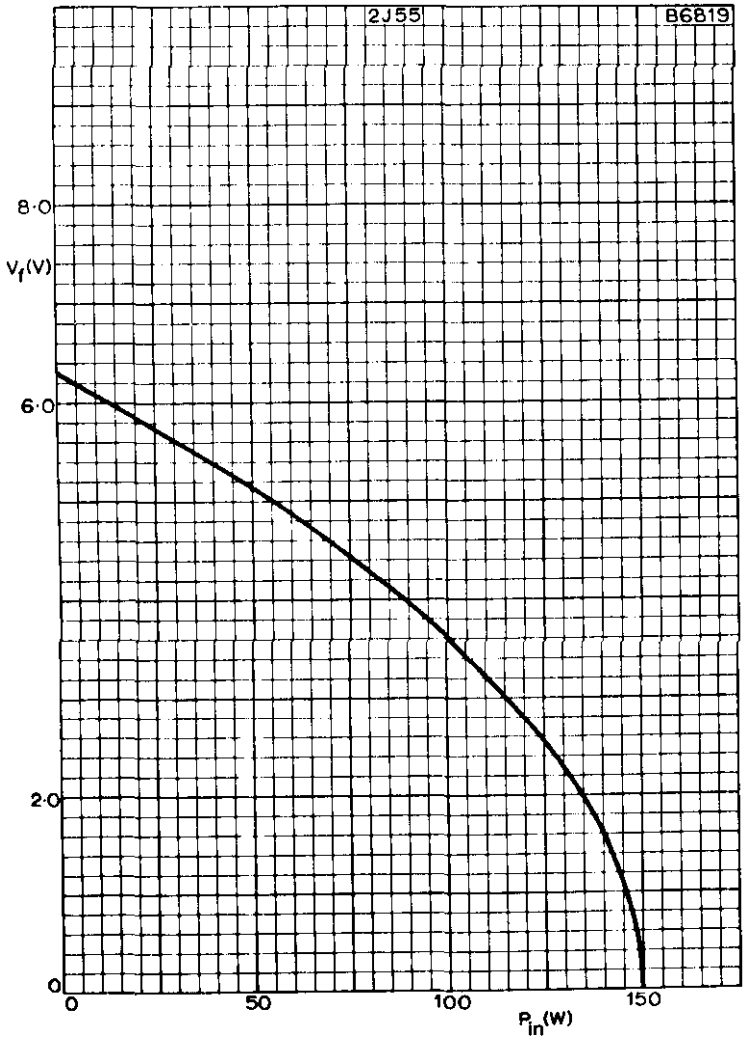

HEATER DERATING CHART

QUICK REFERENCE DATA

Frequency	9.245	GHz
Power output (pulsed)	50	kW
Construction		Packaged

To be read in conjunction with
GENERAL OPERATIONAL RECOMMENDATIONS - MICROWAVE DEVICES

OPERATING CONDITIONS

R. F. pulse power output	50	50	kW
Duty factor	0.00033	0.001	
Pulse duration	0.1	1.0	μ s
Pulse repetition frequency	3300	1000	p.p.s.
Heater voltage (running)	5.0	0	V
Pulse current	12	12	A
Pulse voltage	12.7	12.7	kV
Pulse input power	152	152	kW
Rate of rise of voltage pulse	100	100	kV/ μ s
Mean input current	4.0	12	mA
Mean input power	50	152	W
Mean r.f. output power	16.5	50	W
Frequency pulling (v.s.w.r. = 1.5)	12	12	MHz

CATHODE

Indirectly heated

V_h	6.3 \pm 10%	V
I_h	1.0	A
I_h (surge) max.	6.0	A
r_h (cold)	0.8	Ω
t_{h-k} (min.)	120	s

It is necessary to reduce the heater voltage immediately after the application of h.t. in accordance with the input power-heater voltage rating chart on page C1.

CHARACTERISTICS

	Min.	Max.	
Frequency (fixed within the band)	9.215	9.275	GHz
Pulse voltage ($I_{\text{pulse}} = 12\text{A}$)	11	13	kV
R. F. pulse power output ($I_{\text{pulse}} = 12\text{A}$)	40	-	kW
Frequency pulling (v.s.w.r. = 1.5)	-	15	MHz
Frequency temperature coefficient	-	0.25	MHz per degC
Input capacitance	-	9.5	pF

RATINGS (ABSOLUTE MAXIMUM SYSTEM)

	Min.	Max.	
Pulse current	11	13	A
Pulse duration	-	2.5	μs
Duty factor	-	0.001	
Mean input power	-	180	W
Rate of rise of voltage pulse	-	150	kV/ μs
Load mismatch (v.s.w.r.)	-	1.5	

END OF LIFE PERFORMANCE

The valve is deemed to have reached end of life when it fails to satisfy the following:

R. F. pulse power output ($I_{\text{pulse}} = 12\text{A}$)		30	kW
	Min.	Max.	
Frequency			
Within the band	9.21 to	9.28	GHz
Pulse voltage ($I_{\text{pulse}} = 12\text{A}$)	11 to	13.5	kV

MOUNTING POSITION

Any

PHYSICAL DATA

	kg	lb
Weight of magnetron	1.7	3.7
Weight of magnetron in carton	4.5	9.9

COOLING

A flow of cooling air may be necessary to keep the anode block temperature below the permitted maximum.

Temperature

Anode block max.	100	$^{\circ}\text{C}$
------------------	-----	--------------------

DIMENSIONS

	Millimetres	Inches	
A	63.5	2.50	max.
B	11.1 ±0.5	0.437 ±0.020	
C	2.16±0.13	0.085 ±0.0051	
D	36	1.42	max.
E	31.6	1.24	
F	4.90±0.07	0.193 ±0.0028	dia.
G	30.15	1.187	
H	36.5 ±0.7	1.437 ±0.028	
J	42.85	1.687	
K	73.0 ±0.13	2.874 ±0.0051	
L	136.47	5.373	max.
M	12.7	0.5	max.
N	1.6	0.063	
O	79.3	3.12	max.
P	34	1.34	rad.
Q	9.5	0.37	
R	69.7	2.74	max.
S	67.6	2.66	max.
T	44.45±0.18	1.750 ±0.0071	
U	52.3	2.06	max.
V	30.3 ±0.5	1.192 ±0.020	
W	11	0.43	min.
X	75.4	2.97	max.
Y	19	0.75	
Z	39.7 ±0.5	1.563 ±0.020	
AA	3.18±0.13	0.125 ±0.0051	
BB	75.8 ±1.6	2.984 ±0.063	
CC	82.5 ±0.7	3.248 ±0.028	

Millimetre dimensions derived from original inch dimensions

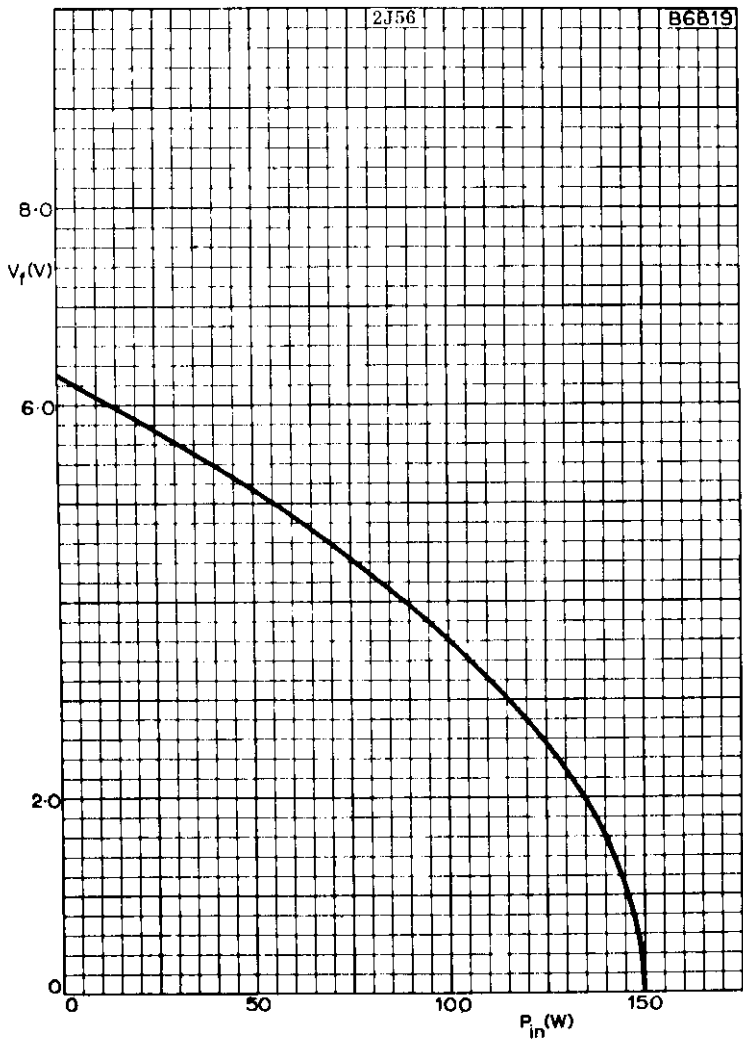

HEATER DERATING CHART