

# E. Dynamic Redundancy

© 2001 J. C. Muzio, M. Serra

Department of Computer Science, University of Victoria

[jmuzio@cs.uvic.ca](mailto:jmuzio@cs.uvic.ca), [mserra@cs.uvic.ca](mailto:mserra@cs.uvic.ca)

**17 slides**

## DYNAMIC HARDWARE REDUNDANCY - Standby Sparing

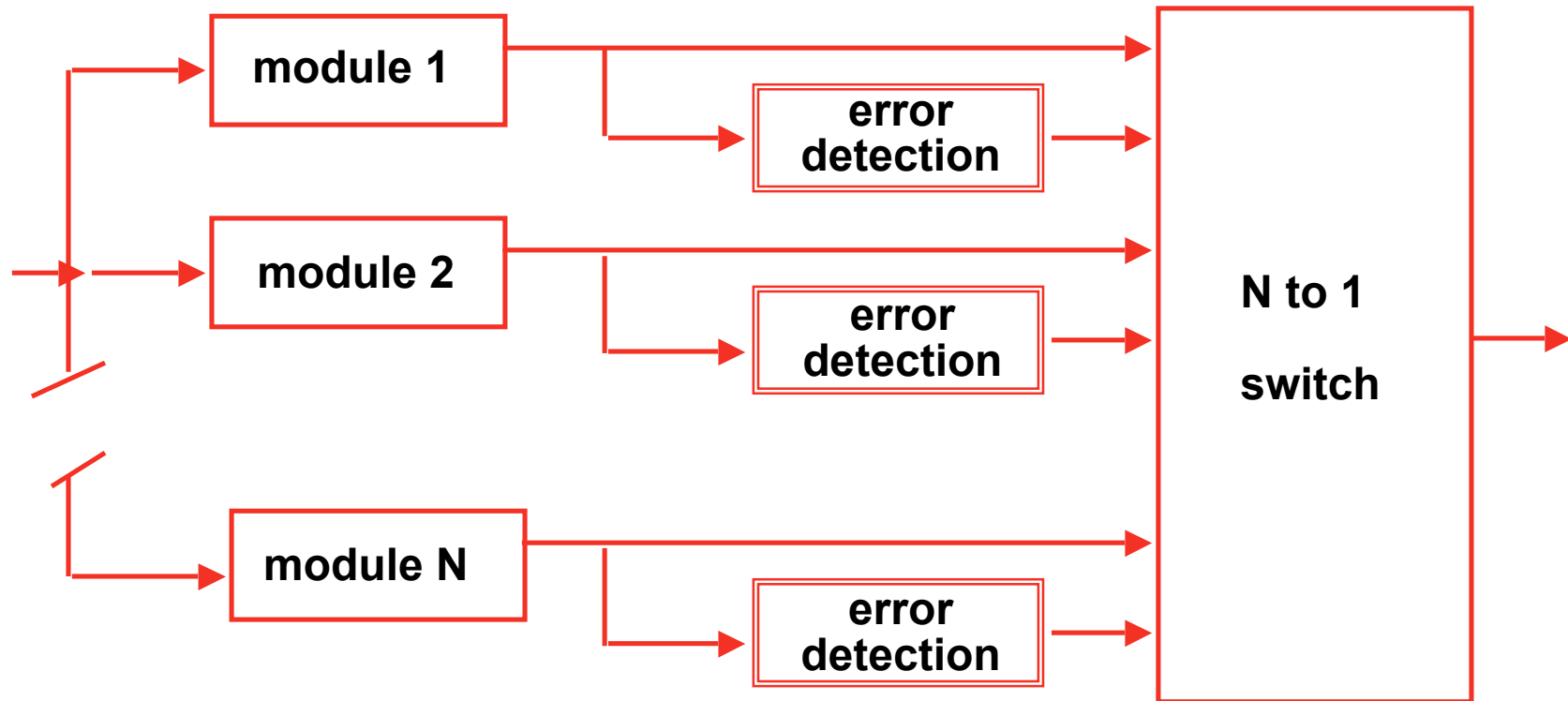

First approach to dynamic redundancy is

## DUPLICATION WITH COMPARISON

STANDBY SPARING : one module is operational, one or more serve as spares

- need good fault detection to determine when a module is faulty and spare is needed
- think of high level switch which selects one input from one module
- selection is made by examining error report which comes together with module output
- reconfiguration technique

### HOT STANDBY SPARING :

- ❖ spare modules are powered
- ❖ operate in synchrony with on line modules
- ❖ ready to take over anytime

### COLD STANDBY SPARING :

- ❖ spares are powered when needed

### PAIR AND A SPARE :

- ❖ at least two modules are always operated at all times and their results compared

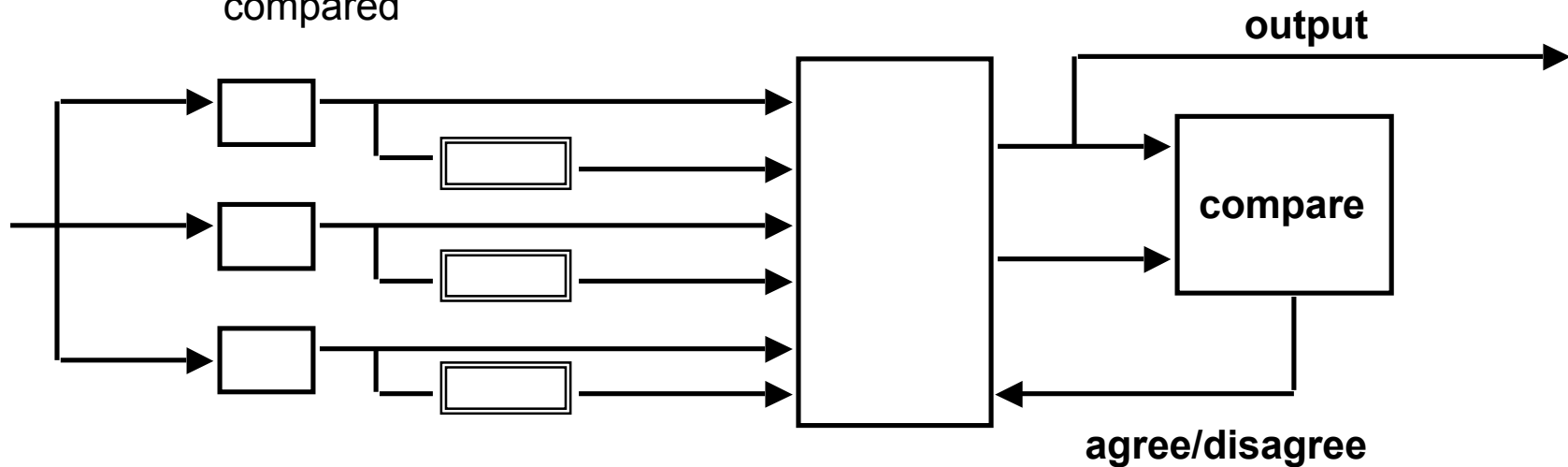

## WATCHDOG TIMER

- a timer which must be reset on a fixed interval
- lack of action on the part of the system indicates a fault
  - i.e. system is fault free if it is capable of performing some repetitive action
- good to detect a dead processor or an overload

# HYBRID HARDWARE REDUNDANCY

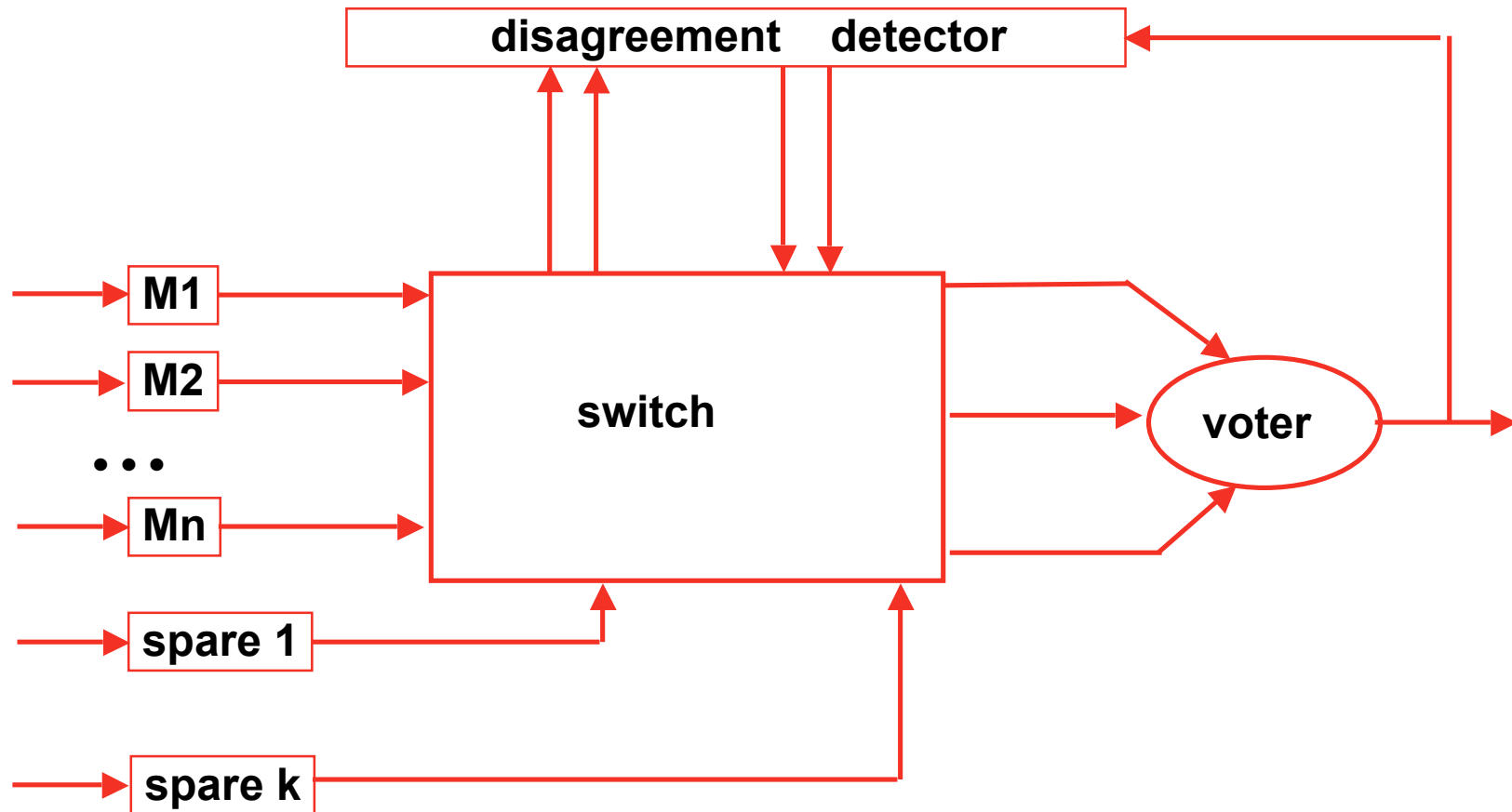

## N modular redundancy with K standby sparing

- the disagreement detector detects that there is a faulty unit
- compare output of voter with output of active modules
- after detection, a spare module is switched in to take place of faulty module

( relative size of switch, etc. must be taken into consideration)

- trying to combine advantages of passive and active redundancy

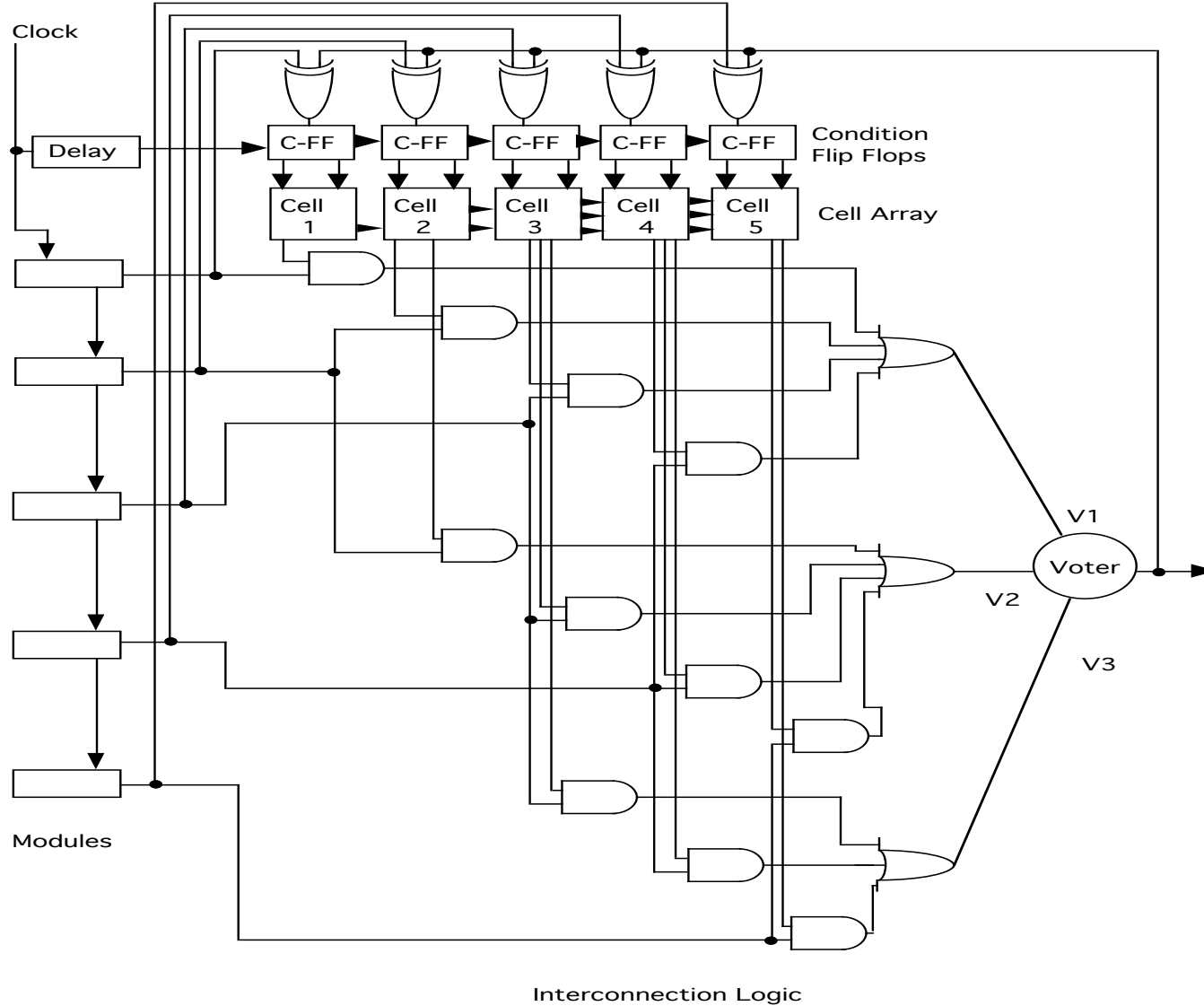

**Interactive cell switch for a hybrid (3, 2) system**

## SELF PURGING REDUNDANCY

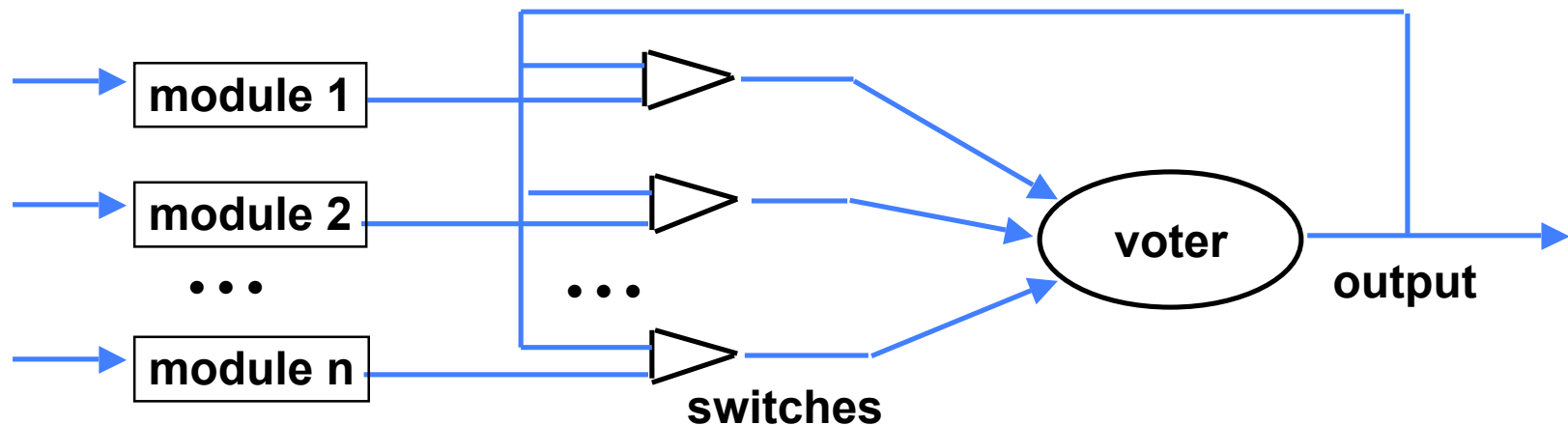

- all units are actively operating
- each module can remove itself if its output disagrees with voted one
- switch forces module output = 0 if there is disagreement
- maintenance can take place while not disturbing system
- voter is a threshold gate ==> difficult to implement
- switching is simple

## VOTER in self-purging is threshold voter

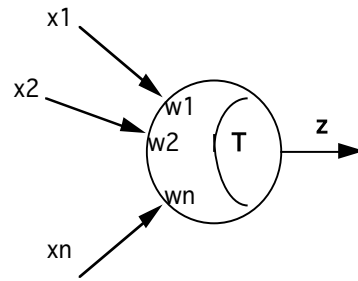

$$z = 1 \quad \text{if} \quad \sum_{i=1}^n w_i x_i \geq T$$

$$z = 0 \quad \text{if} \quad \sum_{i=1}^n w_i x_i < T$$

weighted sum, real numbers, T is threshold

if  $n = 3$ ,  $w_i = 1$ ,  $T = 2$   $\implies$  majority voter

- one approach : force to zero the weight of faulty modules, hence they do not contribute to sum of output
  - vary threshold to allow different minimum number of modules to control output
- § analog, i.e. difficult : not really practical, makes self purging impractical

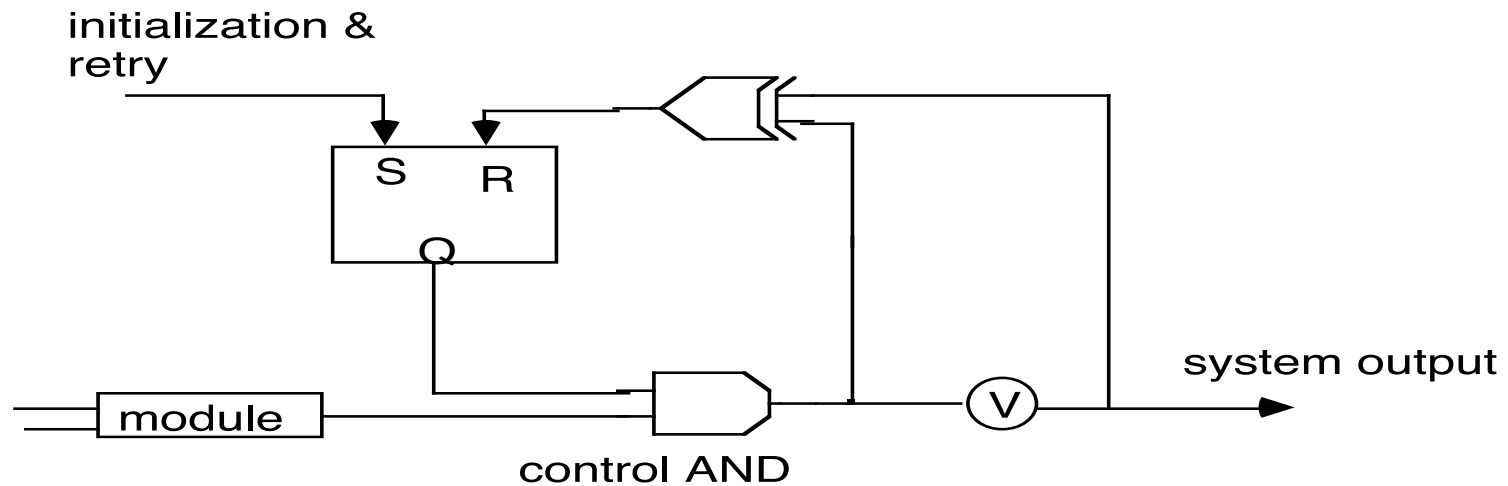

- elementary switch for self-purging system
- module is retried after a disagreement, before removal
- S input of FF can reset control AND gate for retry
- if permanent fault, then AND gate removes module from system
- failed module can be repaired and reconnected

# SIFT OUT MODULAR REDUNDANCY

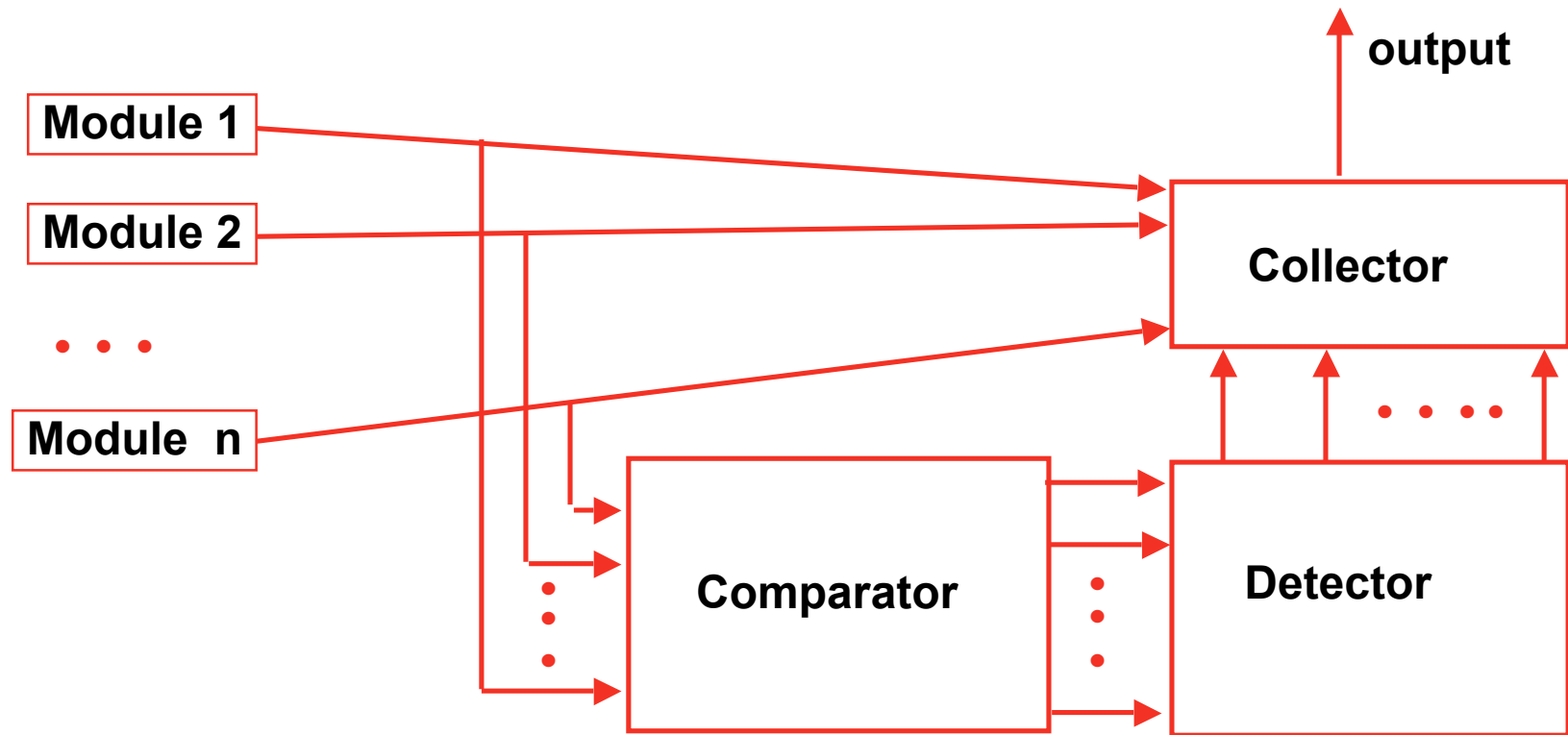

- comparator compares each module output to others
- detector decides which unit disagrees from others and eventually disable it
- collector gets all signals, avoids taking into consideration the value from faulty module as signaled by detector
- more centralized bureaucracy to getting rid of faulty modules
  - § in self purging, modules decided for themselves after comparing with voted output
  - § here detector decides fate of modules
- comparison of hardware overhead between the two gives VERY similar results in terms of number of gates, but not sure about connections

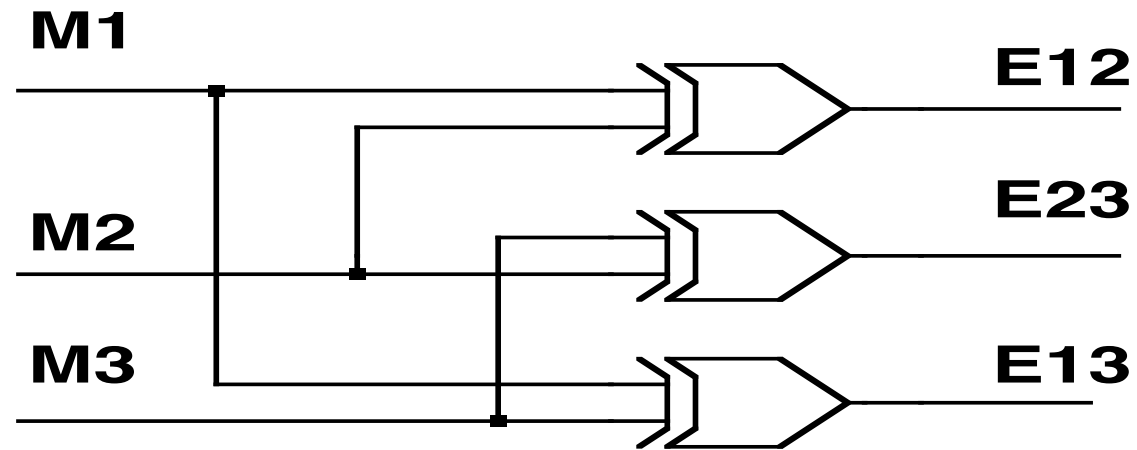

comparator for 3 channels

• in general  $\binom{L}{2}$  EXOR gates

- if channel 1 has failed, it disagrees with other channels
- hence lines E12 and E13 are at logic 1

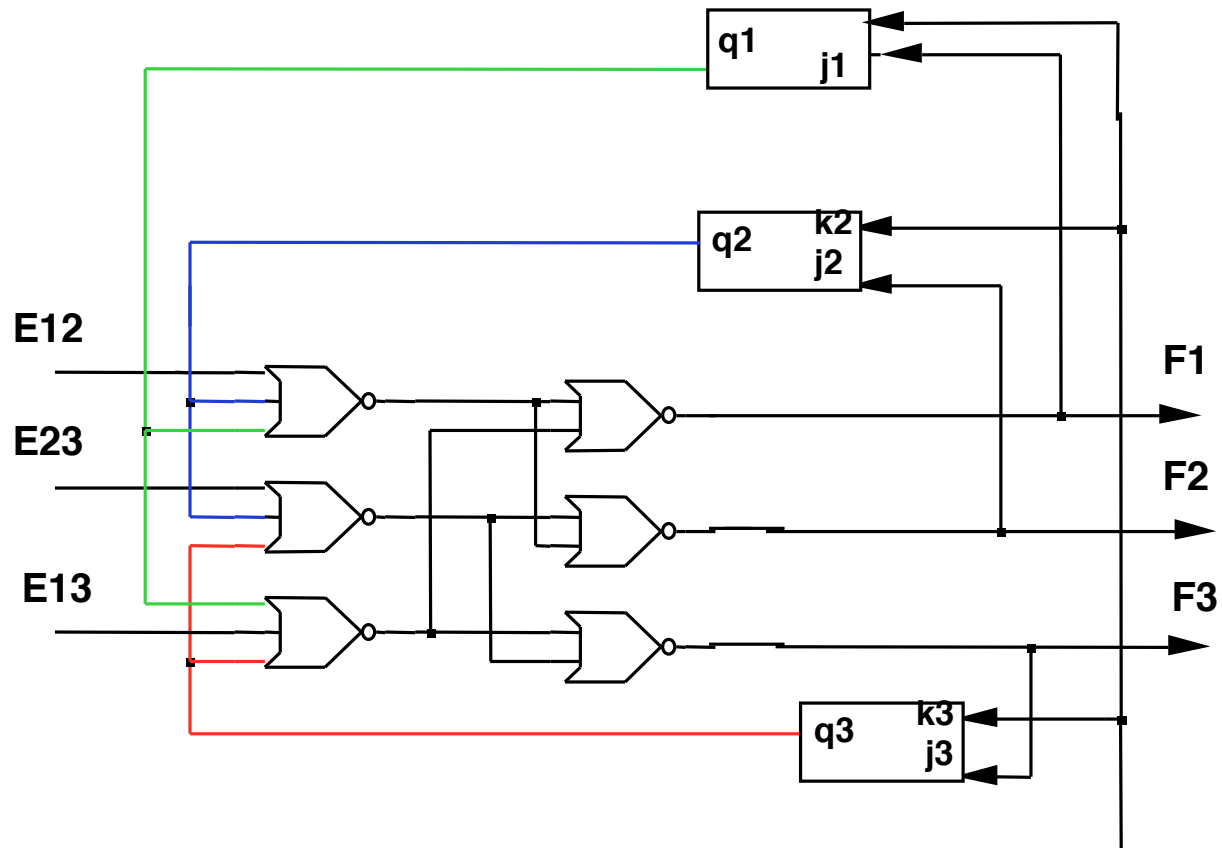

- detector for 3 channels

- $\binom{L}{2} + L$  NOR gates, plus reset/retry for feedback loop

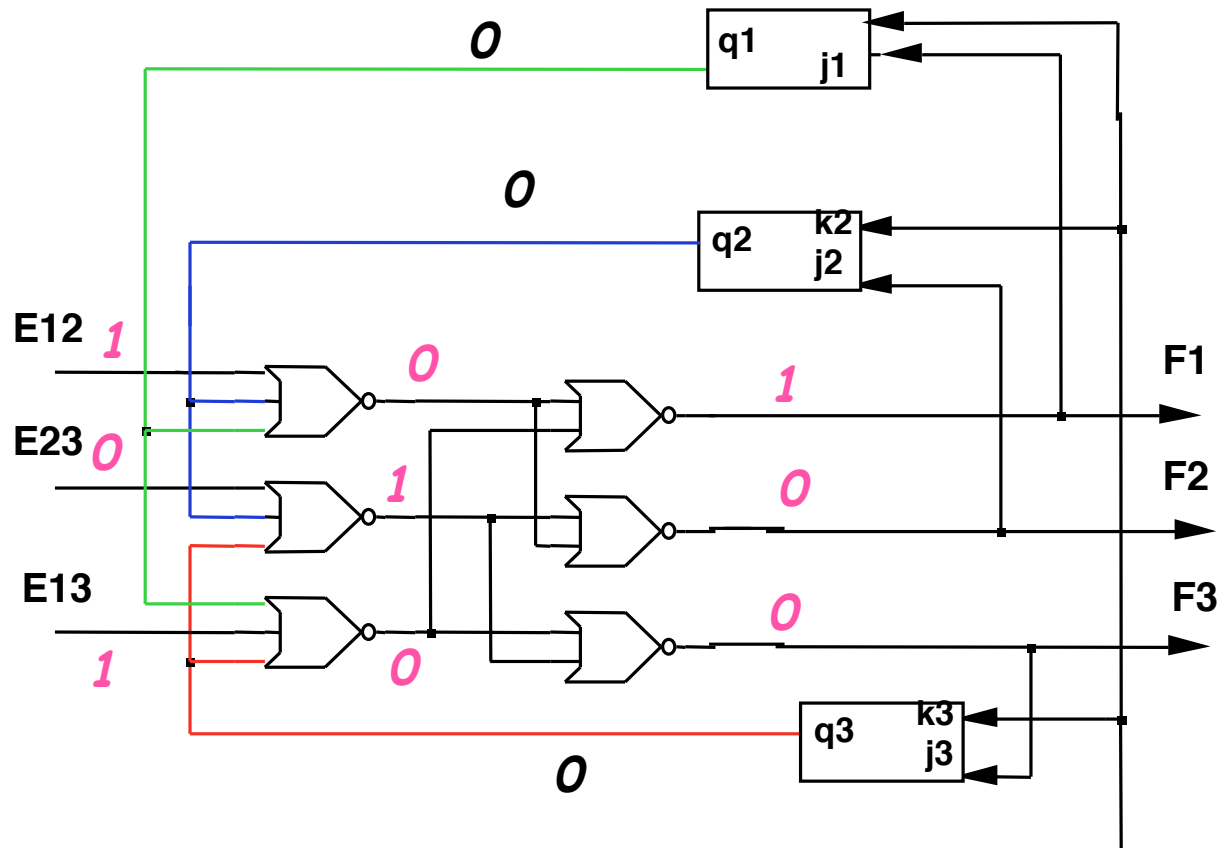

- detector for 3 channels

- $\binom{L}{2} + L$  NOR gates, plus reset/retry for feedback loop

- if channel  $i$  is fault free, then  $F_i = 0$  but if channel  $i$  is faulty, then  $F_i = 1$
- § given  $E_{12} = E_{13} = 1$ , outputs of 1st level NOR are 010 (from top), assuming outputs of FF = 0 (not in retry mode)
- § 2nd level NOR is (from top) 100, hence  $F_1 = 1$  and  $F_2 = F_3 = 0$
- $k$  inputs to FF is retry or reset, makes it easy to start a separate check
- NOTE : it is a sequential circuit ( i.e. synchronization problems )

collector for 3 channel SMR

- $D_i$  come directly from modules
- $F_i$  come from detector
- good channel  $D_i$  feeds  $D_i'$  to last NOR
- bad channel feeds a 0 to last NOR
- final output is correct if at least 2 modules are correct
- in general collector needs  $L+1$  NOR (combinational)

