

AMTOR, the forgotten digital mode.

What is AMTOR? It's a near error free digital mode that uses error detection and correction. This mode has been around so long that all the multimode terminal node controllers (TNC's) have this mode in them even if they have never been upgraded to later update chips. This mode is fun and provides almost perfect copy with poor band conditions. With just a little effort you can get an all mode TNC and explore this digital mode. Dig that old TNC out of the dust pile and have fun with it again. You can also buy them cheap, even on ebay they are selling for less than the cost of a "Store bought" PSK-31 interface! The TNC of my choice is the PK-232 or later model PK-232MBX. Even Heathkit supplied the PK-232 under the Heathkit label in kit form as the HK-232. Best of all Timewave (www.timewave.com) still supports this family of TNC's. Timewave, Kantronics and MFJ still sell new all mode TNC's but they cost a lot more than a PSK-31 interface or a used TNC. If you do buy a used TNC make sure it works first or has some kind of DOA warranty. Also get the manual, you WILL need it!

There are two distinct modes in AMTOR. Mode-A which is ARQ (Automatic Reception ReQuest) and Mode-B is FEC (Forward Error Correction). Mode-A requires precise timing between the linked stations and so you can not use a computer sound card and program to operate this mode, you must have a TNC with this mode programmed into it. Mode-B however is like RTTY and some sound card programs allow you to operate in AMTOR Mode-B. Mode-A operation links two stations with each of the stations taking turns being a sending station and a receiving station. AMTOR Mode-A stations linked will produce a distinct rapid chirp...chirp sound. The sending station will send a chirp and then the receiving station will respond with a chirp telling the sending station to resend the data if there was an error detected or to send the next chirp of data. This process continues until the sending station has sent all its data. At this point the change over of sending and receiving stations is required. To make the change from being the sending station to the receiving station only requires that the sending station sends a plus sign followed by a question mark like this +? .

Linking in AMTOR ARQ mode requires a 4 character station call or Selcal and is made up using your FCC call sign. No numbers are allowed in your Selcal so as an example my FCC call sign is N4ZOU and so my Selcal is NZOU. If you are using a PK-232 TNC the software will simply select your Selcal by entering your full call sign at the **MYSELCAL** command. Example cmd:**MYSELCAL N4ZOU**. Then if you enter **MYSELCAL** at the cmd: prompt it will show as cmd:**MYSELCAL NZOU**. Another example of a Selcal for a 2 X 3 call sign is KC4UYS would become KUYS and a 1 X 2 or 2 X 1 call sign N0AB would be NNAB. If you are using another type of TNC then you will need to read your manual on how to enter your Selcal. NOTE: You CAN NOT use your Selcal as a proper station ID while in AMTOR! You must send your full call in the text of your transmissions. Using a PK-232 TNC to start an ARQ AMTOR contact is simple. First find a station calling CQ or Make a CQ call yourself.

An example would be....

```
CQ CQ DE N4ZOU N4ZOU N4ZOU NZOU NZOU.  
CQ CQ DE N4ZOU N4ZOU N4ZOU NZOU NZOU.  
CQ CQ DE N4ZOU N4ZOU N4ZOU NZOU NZOU.  
PLEASE CALL IN THIS MODE OR LINK IN AMTOR.  
DE N4ZOU NZOU PSE K
```

A few years ago this CQ would have been done in AMTOR FEC mode and you would expect a quick return. This is no longer possible as there is almost no AMTOR activity. What I do is to give the CQ call in RTTY (Baudot) mode. This allows making contacts with simple RTTY terminals and stations using sound card modems and software. They can give you a call in the mode they can operate in. However, if a station using an all mode TNC copy' s your CQ text and has AMTOR mode they will see the four character Selcal in the CQ text and can switch to AMTOR mode and attempt to link. At this point you would switch to AMTOR mode after hearing the distinctive chirp....chirp of an AMTOR station trying to link to you. With a PK-232 the command would be cmd:**OPMODE AMTOR**. If everything is setup properly your transceiver will start to key and unkey quickly and the linking station will be the sending station and start sending you text. If on the other hand you find a station calling CQ with AMTOR information in the CQ text simply switch to AMTOR mode and enter there Selcal ID.

With a PK-232 TNC and a dumb terminal program you would enter cmd:**OPMODE AMTOR**. Now enter the command **ARQ NZOU** if you were calling N4ZOU or the Selcal of the station your trying to link with. If your using a different type of TNC and software you will need to read your manual. Again the software change over command is +? . Example..BTU KC4UYS DE N4ZOU K +?

Ending an ARQ contact with a PK-232 is easy. The sending station at the end of the contact would send both stations calls and <ctrl-d> instead of the change over sign of +? . Example THANKS FOR THE NICE AMTOR CONTACT. HOPE TO LINK AGAIN. 73 KC4UYS DE N4ZOU SK <ctrl-d> . At this point both stations will shutdown.

Where to operate. When AMTOR was still active you could hear them on 20 meters between 14.065 and 14.085. Today I would give PSK-31 operators a break on 14.070 and not get too close to them. RTTY (Baudot) starts at around 14.080 up to around 14.090. I normally call CQ in RTTY mode on 14.079 with both AMTOR and PACTOR link information in the text. I have a PK-232MBX that can automatically switch between AMTOR and PACTOR so it' s no problem trying to figure out which mode there trying to link in.

NOTE: If your using AFSK you must have your transceiver set to LSB mode.

Using both a PK-232 and sound card PSK-31 interface on one RS-232 comport. Yes, you can use just one RS-232 port for both your PK-232 TNC and your RS-232 keying circuit PSK-31 interface. The PK-232 needs only three wires connected to the RS-232 port. Just make sure the TNC and software is setup for XON/XOFF flow control. SO you can make up a cable with only three wires connected between the computer RS-232 port and TNC. RX data, TX data, and signal ground. Now DTR, RTS and signal ground on the same RS-232 comport are available for use with your Sound card interface.

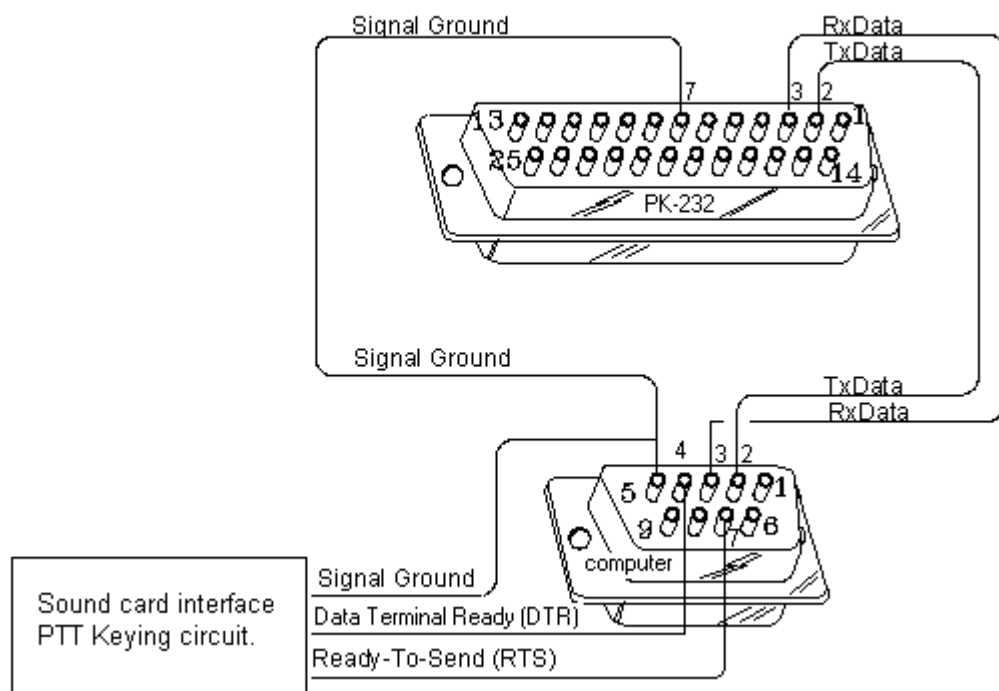

I used a Radio Shack RS 232 Shielded Jumper Box 276-1403A between the serial cable from the computer and the back of the PK-232MBX. Pins 2,3, and 7 were connected through and then I used a 2 wire with shield cable connected to the computer side of pins 4 and 20 with the shield soldered to pin 7. I drilled a small hole in the side of the plastic case of the jumper box just large enough for the cable to pass through it. I used both RTS and DTR just to make sure I would not have a problem with any of the software available for use with the sound card modes that use RTS or DTR for transmitter keying. This setup works fine and I have no problem with either the PK-232 or sound card interface using the same comport.

Software, There is some good software and some bad software available for use with the PK-232 and other TNC' s. In Windows 3.1 and up you can load Hyper Terminal and it will work just fine. Procomm is also a good terminal program if you can still find a copy of it and you don' t mind working in DOS mode. My choice of software is PC-Pakratt II for DOS with a PK-232 and will operate under Windows 95 and 98, I don' t think it will operate under Windows XP. Also PC-Pakratt for Windows works very good with the PK-232MBX. I just found a very good Windows PK-232MBX terminal program that I downloaded for free that works great! <http://web.inter.nl.net/hcc/PA0NC/> Will take you to the home page and from there you can download ncw95pk.zip. This program works only with the PK-232 and PK-900 TNC' s.

Good luck with your AMTOR project and hope to link with you soon!

Scott N4ZOU

My current e-mail address is n4zou@hotmail.com