

( ) :

( ) ( )

:

( ) ( )

( , ) /

( , )

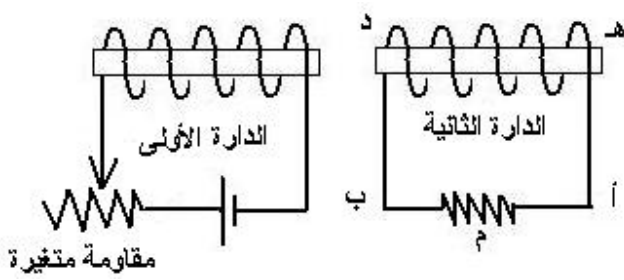

(II) (I) :

( ) ( )

:

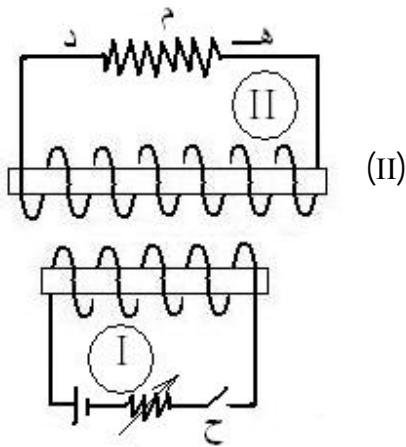

( Δ )

(II)

( )

(I)

( , )

:

( ) ( )

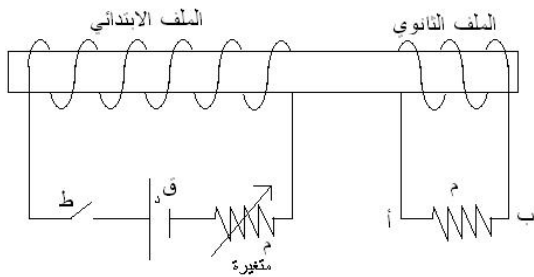

:

( )

( )

( )

( )

( - × , ) /