

# CENTRAL VALLEY #1904 HO SCALE DOUBLE TRACK 72' PLATE GIRDER BRIDGE

## TOOLS AND MATERIALS REQUIRED

1. Modelers Knife
2. Fine toothed razor saw
3. Flush cutting nippers (de-gating tool)
4. Tweezers
5. Flat ended punch
6. Styrene cement & brush
7. Painting apparatus & Paint

## GENERAL NOTES

Please read through all instructions before beginning project. Clean flash from parts before removing parts from sprues if possible. Cut, **DO NOT BREAK**, parts from sprues. This bridge can be painted after assembly.

## ASSEMBLY INSTRUCTIONS "Girder Assemblies"

1. With the wider edge toward the outer face, cement bottom flange plates **1** to main side girders **2**. Make certain that they are cemented with an equal amount of over-hang on the bottom ends of the plate girder. On one of the three girders, remove interfering ribs on the out-board side to allow installation of second track section.
2. Align and fit the short flange plates **3** to the ends of the main side girders **2** and cement all four of them into position.
3. Align and fit the curved corner plates **4** to the corners of the main side girders **2** and short flange plates. Then glue all four them into position.
4. Align, fit, and trim the final long "stacked" flange plate **5** to the top edge of the main side girders **2** and cement the two of them into position.

## "Track Assembly"

1. Working on a solid surface, secure rails (not included) to the tie section **6** by locating the foot of each rail between the molded spikes in the tie plate detail. With a flat-ended punch, use finger pressure to mash each spike over the foot of the rail. Work from the center outward, mashing over all spikes on each tie plate about every ten ties, and then going back over the remaining spikes after the rail is roughly spiked.

**NOTE:** The rail can also be secured with Barge shoe repair cement, contact cement, Walthers "Goo", and/or many other epoxies, etc. The tie section(s) are designed to accept code 70 or 83 rail sizes, however, some brands of code 100 will also fit. If a ballasted floor bridge is desired, cut and cement a .020" styrene floor to fit inside the bridge assembly before installing the triangular brace **7** pieces.

## "Bridge Assembly"

1. Align, and locate the ribs on the three main girder assemblies with the cross bearers of the floor assembly **8** (detail (A)), secure and cement at each cross bearer location twentyfour places in all.
2. Locate twelve triangular brace **7** pieces and cement between locating ribs on girder assemblies. Each brace should seat down on the top edge of each cross bearer section.
3. Align and cement the track assembly to the bridge cross bearer or styrene floor depending on style of bridge.
4. Scrape rivets away from the bottom flange at the four corners under the bridge and cement the four mounting feet **9** in place.
5. Paint and weather your bridge as desired.

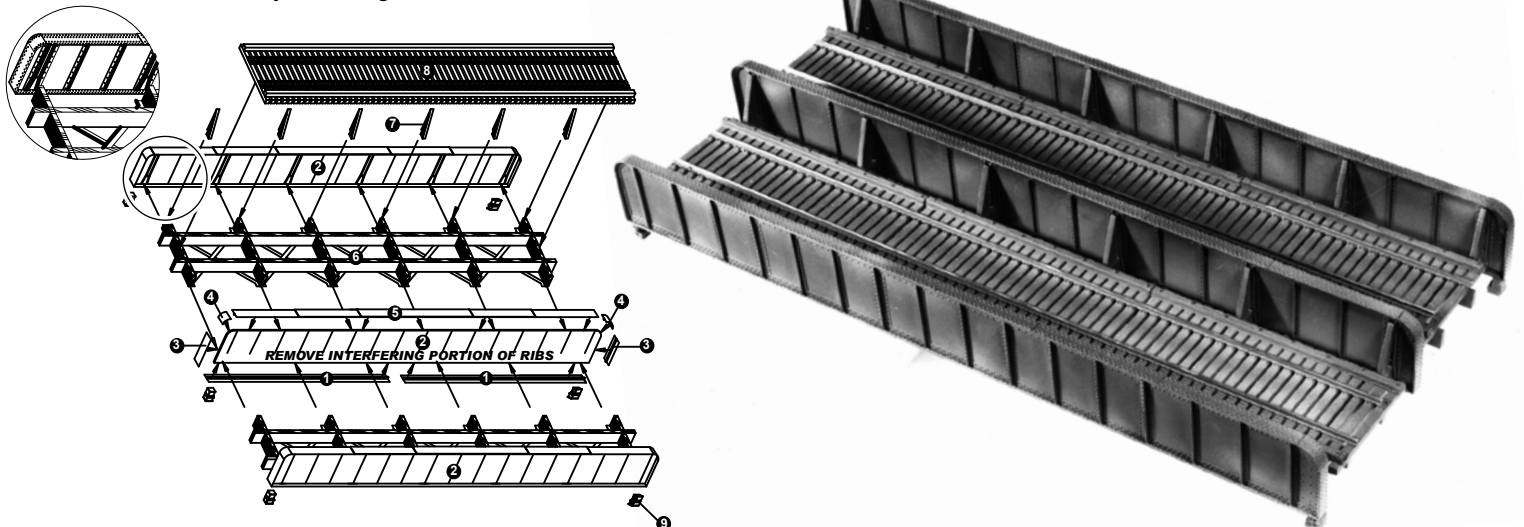

This highly detailed injection-molded styrene kit fills a long over due need in model railroading. Until now, only very primitive or absolutely "Toy" versions of this common and widely used bridge type has been available in any scale. Now, exciting, super detailed plate girder bridges are available featuring easy assembly and reasonable cost.

