

'RAILMARKS'

N.S.W.G.R. Standard 9" Water Column Kit

1. Clean off all flash and excess metal, noting especially the areas around the top guide-wheel, and fill any pits and file smooth.

2. Drill three holes in the hand wheel (scale 2 1/4") thus;

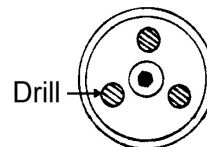

3. Affix the main casting into the base plate and when dry, remove any excess spigot below the base plate.

4. Glue the base plate and crane onto the two foundation blocks. The nuts on the base plate should be over the centre line of the foundation blocks, which may require that their bases be slightly filed so that the whole assembly stands vertical.

5. Painting:

The N.S.W.G.R. used a semi-standard colour scheme of silver (aluminium) and black, and some examples are shown below

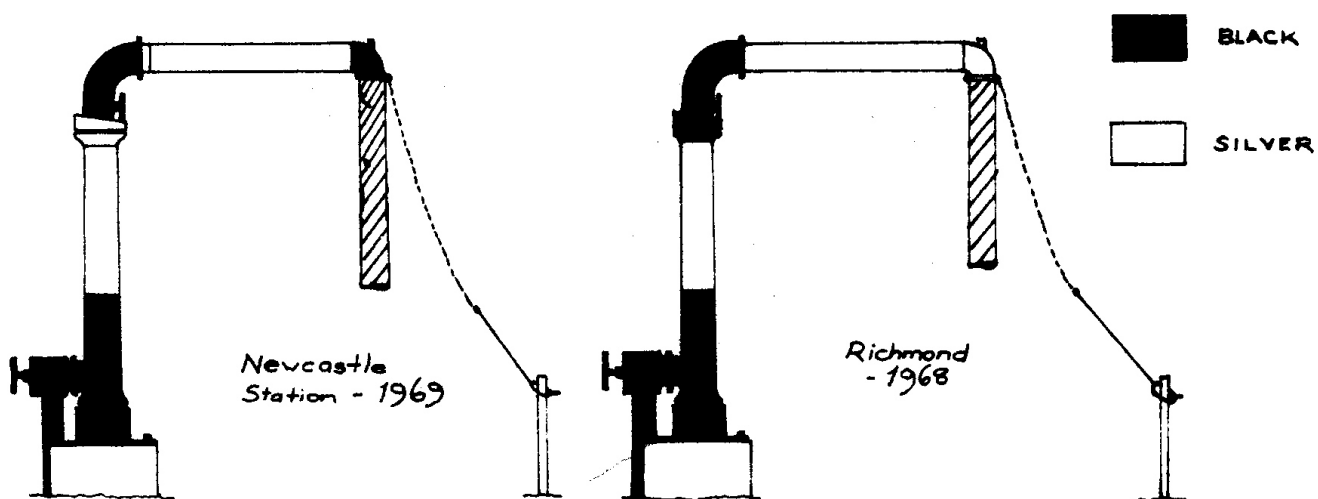

The foundation blocks should be painted to represent weathered concrete. Weather the whole column and add rust streaks where leaks would occur, around the upper swivel joint and the inlet cock.

6. Finally push the hose onto the spigot at the outlet end of the crane and squeeze flat. Trim the hose to length (approx 5 feet) and paint to represent leather.

7. Further detail such as chain and ground drain pit may be added as desired.