



European  
co-operation for  
Accreditation

---

*Publication  
Reference*

**EA-10/11**

---

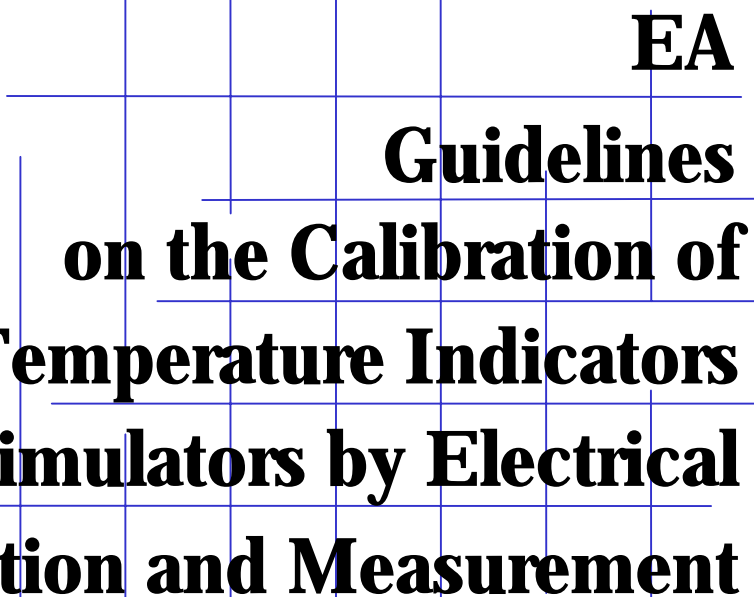
A blue grid pattern is overlaid on the page, centered behind the title text.

**EA**  
**Guidelines**  
**on the Calibration of**  
**Temperature Indicators**  
**and Simulators by Electrical**  
**Simulation and Measurement**

***PURPOSE***

This document has been produced by EA as a means of giving advice for calibrating temperature indicators and simulators by electrical simulation and measurement. It serves to promote the use of consistent procedures and represents a consensus of EA member opinion. These approaches taken are for the guidance of both the accreditation bodies and their client laboratories. This document was approved by the EA General Assembly in November 1999.

*Authorship*

This document has been prepared by EA Committee 2 (Technical Activities), based on a draft produced by the EA Expert Group “Temperature and Humidity” together with the EA Expert Group “DC + LF Electrical Quantities”.

*Official language*

The text may be translated into other languages as required. The English language version remains the definitive version.

*Copyright*

The copyright of this text is held by EA. The text may not be copied for resale.

*Guidance Publications:*

This document represents a consensus of EA member opinion and preferred practice on how the relevant clauses of the accreditation standards might be applied in the context of the subject matter of this document. The approaches taken are not mandatory and are for the guidance of accreditation bodies and their client laboratories. Nevertheless, the document has been produced as a means of promoting a consistent approach to laboratory accreditation amongst EA member bodies, particularly those participating in the EA Multilateral Agreement.

*Further information*

For information about this publication, contact your national member of EA. Please check our website for up-to-date information <http://www.european-accreditation.org>

---

## **CONTENTS**

---

1	SCOPE .....	5
2	TERMINOLOGY .....	5
3	CALIBRATION PRINCIPLES .....	7
4	CALIBRATION REQUIREMENTS.....	8
5	UNCERTAINTY .....	12
6	REPORTING OF RESULT .....	12
APPENDIX A .....		14
A1	MEASUREMENT PROCEDURE.....	14
A2	MEASUREMENT RESULTS .....	14
A3	MODEL OF MEASUREMENT .....	14
A4	UNCERTAINTY CONTRIBUTIONS .....	16
A5	UNCERTAINTY BUDGET .....	17
A6	STATEMENT OF CALIBRATION RESULT .....	18



## **1 SCOPE**

- 1.1 This guide is applicable to the calibration, by electrical simulation and measurement of temperature indicators and temperature simulators intended for use with resistance thermometers or standardised thermocouples and of simulators which are intended to emulate the electrical outputs of resistance thermometers or standardised thermocouples. Indicators and simulators for thermocouples may be with or without reference junction compensation.
- 1.2 Under normal conditions of use, temperature indicators are used in conjunction with a temperature sensor in order to measure temperature. Calibration by electrical simulation, as described in this document, only verifies the accuracy of the temperature indicator itself. It does not take into account the metrological performance of any temperature sensor which will be used subsequently with the indicator.
- 1.3 The user must ensure that both the indicator and the sensor have been calibrated, either separately or as a system, in order to make traceable temperature measurements. Similarly, in addition to the electrical calibration of temperature simulators described in this document, any thermocouples used in conjunction with a temperature simulator must also be calibrated over an appropriate temperature range before being used to connect the simulator to instruments under test.

## **2 TERMINOLOGY**

- 2.1 Definition of general metrological terms used in this document are to be found in the International vocabulary of basic and general terms in metrology (VIM Second edition, 1993 ISBN 92-6701075-1 © International Organization for Standardization 1993).
- 2.2 Simulation: In this application, simulation is the process of replacing a temperature sensor (thermocouple or resistance thermometer) by an equivalent electrical device in order to calibrate a temperature indicator.
- 2.3 Temperature indicator: An indicating device which is normally used in conjunction with a temperature sensing device to measure temperature. The device indicates in temperature units a value derived from the measurement of a temperature dependent input parameter such as resistance or thermal EMF. The conversion from electrical parameter into temperature units is normally based on standard reference tables.
- 2.4 Temperature simulator: A source of electrical signals whose output, for a given setting, correspond to the output of a temperature sensor at a temperature equal to the setting of the simulator. The setting of the temperature simulator is usually given in temperature units. A single temperature simulator may have the capability of simulating the output of several types of temperature sensors. The relationship between the simulator's setting and its electrical output is normally based on standard reference tables. Temperature simulators often also provide direct setting for electrical output signals.

- 2.5 Standard Reference Tables: Standard reference tables provide, for specified thermocouples and resistance thermometers, tabulated values and/ polynomial relationships for voltage or resistance conversion into the equivalent temperature and vice versa.
- 2.6 Resistance Thermometer: A temperature sensitive resistor with a known functional relationship between its resistance and sensed temperature. A common type of resistance thermometer is a platinum resistance thermometer with an nominal resistance value at 0 °C of 100 Ω (IEC 751 : 1983).
- 2.7 Two wire resistance measurement: A resistance measurement whereby the resistance is connected to the resistance measuring instrument by means of two wires. The indication of the measuring instrument includes the resistance of the connecting wires and contact resistances.
- 2.8 Three wire resistance measurement: A resistance measurement technique whereby the resistance is connected to the measuring instrument using three wires. The instrument has three measuring terminals, two of which are connected to a common point at the measured resistance. This technique is used to compensate for lead resistance.
- 2.9 Four wire resistance measurement: A resistance measurement technique whereby four wires are used to connect the resistance to the measuring instrument. The instrument is provided with two pairs of terminals, one pair (termed the current terminals) provides the measuring current, while the other pair (termed the potential terminals) measures the potential drop across the resistance. The indication of the measuring instrument is that defined by the connection points of the potential leads at the resistor. Lead and contact resistances are eliminated from the measurement.
- 2.10 Thermocouple (IEC 584-1 : 1995): Pair of conductors of dissimilar materials joined at one end and forming part of an arrangement using the thermoelectric effect for temperature measurement.
- 2.11 Thermoelectric (Seebeck) effect (IEC 584-1 : 1995): The production of an electromotive force (E) due to the difference of temperature between two junctions of different metals or alloys forming part of the same circuit.
- 2.12 Compensating cables (IEC 584-2 : 1982): compensating cables are manufactured from conductors having a composition different from the corresponding thermocouple but with similar thermoelectric properties.
- 2.13 Extension cables (IEC 584-2 : 1982): Extension cables are manufactured from conductors having the same nominal composition as those of the corresponding thermocouple.
- 2.14 Measuring junction (IEC 584-1 : 1995): That junction which is subjected to the temperature to be measured.
- 2.15 Reference junction (IEC 584-1 : 1995): That junction of the thermocouple which is at a known (reference) temperature to which the measuring temperature is compared.

- 2.16 Ice point: The temperature realized at the equilibrium between ice and water (0 °C). This temperature can be realized, using suitable procedures (Techniques for approximating the International Temperature Scale of 1990 -BIPM - 1990) to within  $\pm 5$  mK.

### **3 CALIBRATION PRINCIPLES**

#### **3.1 Calibration of temperature indicator**

- 3.11 A temperature indicator operates by converting the electrical signal received from a sensor into an equivalent readout in temperature units. The calibration principle is based on the verification of this conversion process by simulation/replacement of the sensor's output by appropriate electrical stimuli.
- 3.12 In the calibration procedure, a calibrated electrical source is substituted for the temperature sensor. Using reference tables, the electrical output of the temperature sensor at the required calibration point is determined and the output of the electrical source set to this level. This electrical signal is applied to the temperature indicator and the indicator's reading compared with the simulated input temperature and the error of indication of the temperature indicator determined.

#### **3.2 Calibration of temperature simulator**

- 3.21 A temperature simulator operates by converting its setting in temperature units to an electrical signal equivalent to that produced by a standardised sensor at the same temperature as the setting. The calibration principle is based on the verification of this conversion process by the direct measurement of the electrical signal produced by the simulator. This conversion is performed in accordance with appropriate standard reference tables.
- 3.22 In the calibration procedure the simulator is set at the required calibration point. The electrical output produced by the simulator at this setting is measured using a calibrated electrical measuring instrument. The measured value is converted into the equivalent temperature using reference tables and the deviation of the simulator setting determined.

#### **3.3 Cold Junction Compensation**

- 3.31 Indicator or simulator conversion is compared with temperature-emf or temperature-resistance reference tables. Reference tables for standard thermocouple types are referred to a reference junction temperature of 0°C, usually referred to as the cold junction temperature. Indicators and simulators are often equipped with cold junction compensation (CJC) in order to take account of this. A reference cold junction and thermocouple wires are used, in addition to electrical instrumentation, to calibrate indicators or simulators equipped with a CJC feature.

## 4 CALIBRATION REQUIREMENTS

The calibration requirements are dependent upon the type of indicator or simulator being calibrated. Further guidance is given in the following table, figures and paragraphs. For each function (indicator and simulator) and for each possible sensor and configurations selected, the following table lists reference standards commonly used, the measurement configurations and corresponding technical requirements. While the calibration methods given below are suitable they are not to be considered as an exhaustive list. Other methods may be used provided they have been shown to be metrologically sound.

Instrument Type	Sensor Type	Reference Standard	Measurement Configuration	See paragraph
Indicator	Resistance Thermometer	Standard Resistors or Decade Resistor	see Fig. 1	4.1, 4.2, and 4.3
Indicator	Thermocouple (CJC off)	DC Millivoltage Source	see Fig. 2	4.1, 4.3, and 4.9
Indicator	Thermocouple (CJC on)	DC Millivoltage Source Reference Thermocouple Ice point reference	see Fig. 3	4.1, 4.4, 4.5, 4.6, 4.8, and 4.9
Simulator	Resistance Thermometer	Ohmmeter	see Fig. 4	4.1, 4.3, and 4.7
Simulator	Thermocouple (CJC off)	DC Millivoltmeter	see Fig. 5	4.1, 4.3, and 4.9
Simulator	Thermocouple (CJC on)	DC Millivoltmeter Reference Thermocouple Ice point reference	see Fig. 6	4.1, 4.4, 4.5, 4.6, 4.8, and 4.9

- 4.1 The reference standards used in these calibrations must be calibrated and characterized for the effects of influence quantities over the applicable measuring range.
- 4.2 The method of connecting the reference resistance to the indicator will depend upon whether the indicator is intended to be used with a two-, three- or four-wire platinum resistance probe. Fig. 1 shows the case where the indicator and the reference resistor are four terminal devices. Lead wires effects and influences from environmental conditions should be either corrected or/and included in the uncertainty budget.
- 4.3 Good quality copper cable must be used to make connections.
- 4.4 There are several ways to realise an accurate reference junction temperature. One way is to locate the thermocouple's reference junction in an environment with a very stable and well defined temperature. For example, a physical ice point, prepared according to the procedure proposed in "Techniques for approximating ITS-90", will

provide a stable temperature of 0 °C with a typical standard uncertainty of 2,5 mK. Alternatively, a large well-insulated copper block at ambient temperature may also be used provided that the block's temperature is measured using an external standard thermometer. An alternative to a physically realised reference temperature is the use of an automatic reference junction device which is an electronic compensation circuit. Such a device must, of course, itself be calibrated before use.

- 4.5 Thermocouple wires or extension cables (the use of compensating cable instead of thermocouple wires or extension cables should be avoided) are used to connect the indicator or simulator to the external reference cold junction. The cables or wires have to be calibrated over a suitable temperature range in the vicinity of the normal laboratory temperature and the corrections to these elements will be taken into account in the measurement process or in the uncertainty estimation. The choice of the thermocouple wires or extension cables depends on the type of thermocouple considered. To calibrate thermocouple wires (or extension cable), one method is to manufacture a thermocouple with these wires and to calibrate it using normal accredited procedures. During the subsequent calibration of a temperature indicator and simulator the thermocouple wires will be used over a limited temperature range (from 0 °C to the temperature of the terminals). Consequently, the calibration of the thermocouple wires should be performed over this temperature range.
- 4.6 The correct polarity of the thermocouple connections should be observed.
- 4.7 The method of connecting the reference ohmmeter to the simulator will depend upon whether the simulator output is configured to simulate a two-, three- or four-wire platinum resistance probe. Fig. 4 shows the case where the simulator and the reference ohmmeter are four terminal devices.
- 4.8 Suitable attention must be given to the electrical insulation of the reference thermocouple.
- 4.9 Precautions must be taken to eliminate or minimize the effects of spurious emfs in the measuring circuit.

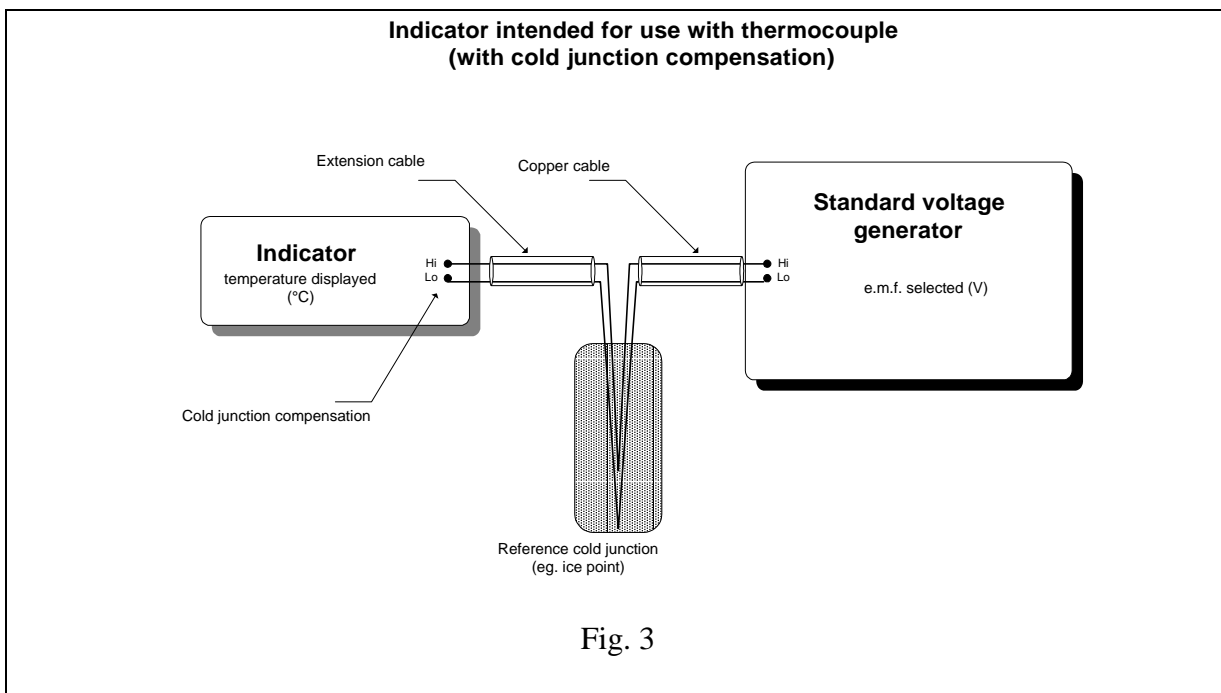
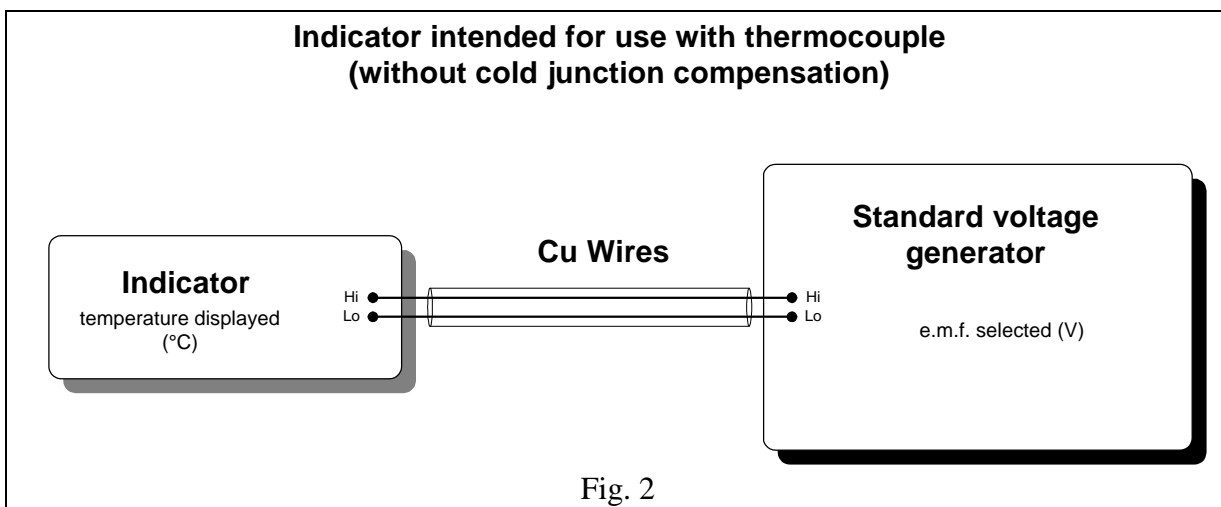
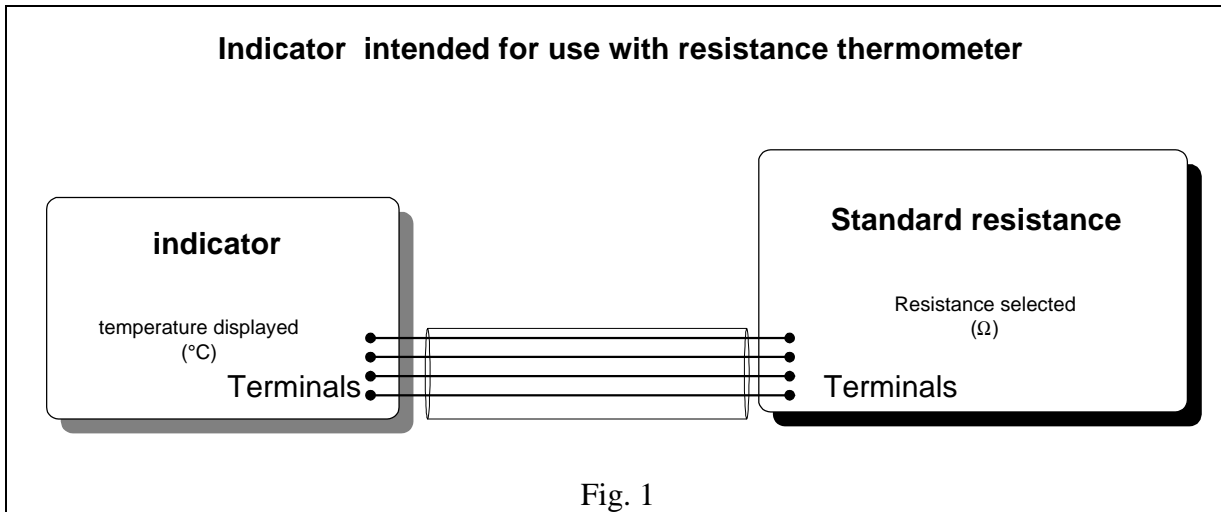

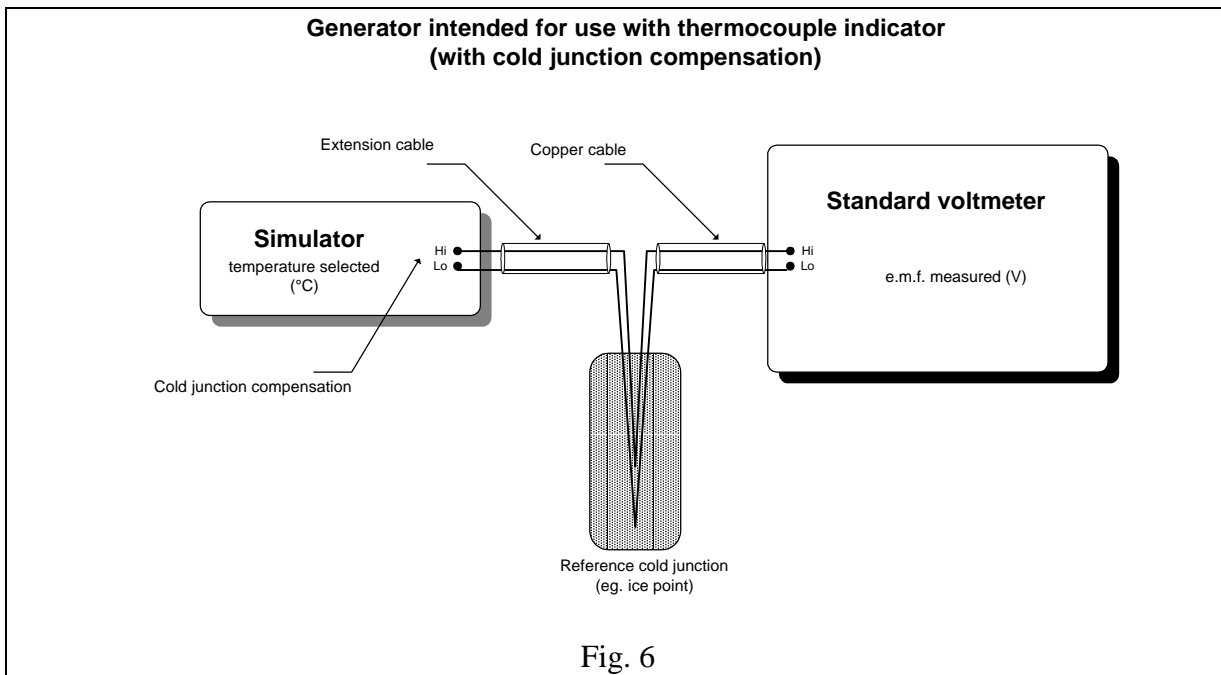
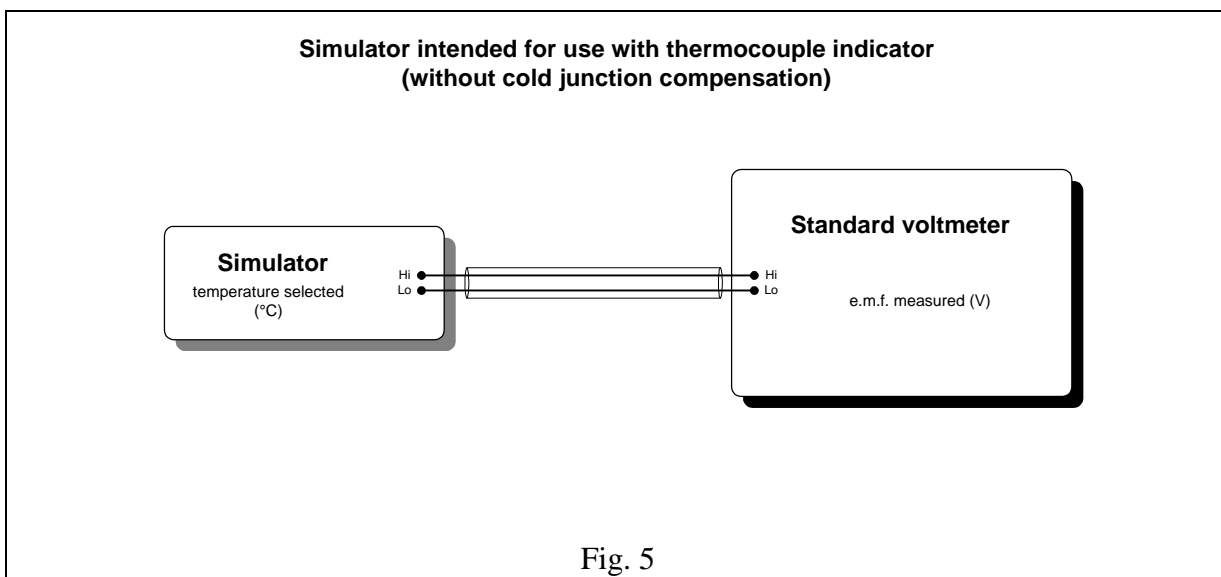
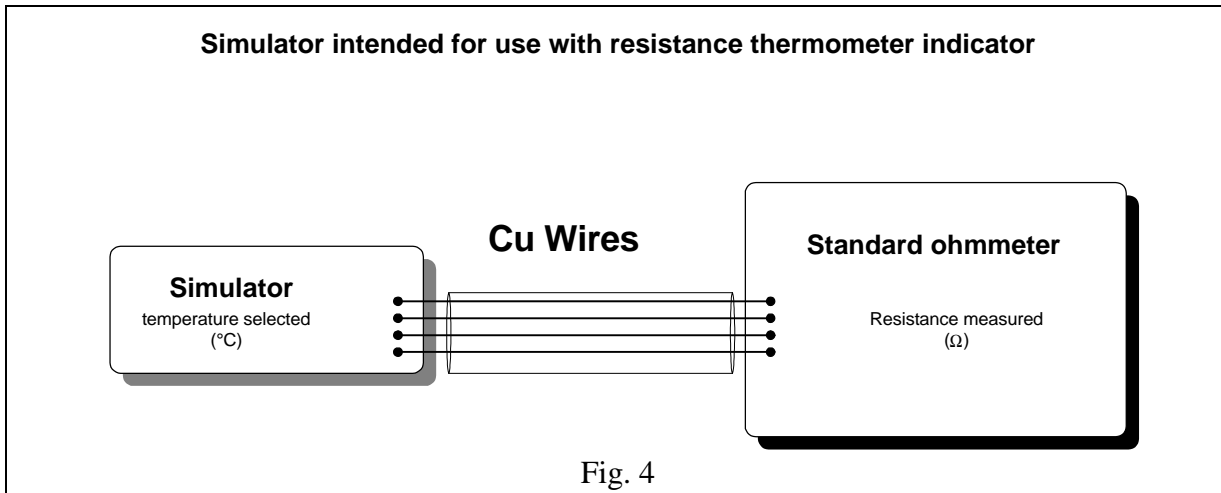

## **5 UNCERTAINTY**

- 5.1 All uncertainties should be calculated in accordance with “The guide to the expression of uncertainty in measurements” (ISO Guide) and EA-4/02 “Expression of Uncertainty of Measurements in Calibration”.

If the component is equivalent to one standard deviation (standard uncertainty), this component will be used directly in the budget of uncertainties.

For determining combined standard uncertainty, it is assumed that all components are independent (uncorrelated). The combined standard uncertainty  $u_c$  is calculated as follows:

$$u_c = [ \sum u_i^2 ]^{1/2}$$

The expanded uncertainty is obtained by multiplying the combined standard uncertainty by an appropriate coverage factor ( $k$ ) to give a coverage probability of approximately 95%.

An example of the uncertainty analysis for the calibration of indicators intended for use with type S thermocouples with cold junction compensation is given in Appendix A.

## **6 REPORTING OF RESULT**

- 6.0.1 The contents of the certificate should comply with the requirements of document EA-4/01 “Requirements concerning certificates issued by Accredited Calibration Laboratories”. In addition to the general requirements contained in EA-4/01, additional information concerning the calibration results should be given as described in the following paragraphs.

- 6.1 The temperature scale used to express temperature values in the calibration certificate should be clearly stated. Preferably the International Temperature Scale of 1990 (ITS-90) should be used. When the use of another temperature scale is requested by the customer, the implications and developments relevant to the applicable standard reference table should be made clear.

- 6.2 In the case of temperature indicators, the calibration results should give, at each measurement point, the equivalent temperature of the electrical stimulus, as determined from the standard reference table, and the corresponding indication of the temperature.

For temperature simulators, the simulator setting and the temperature corresponding to the measured output electrical signal, as determined from the standard reference table, should be given at each measurement point. It should be clearly stated on the certificate that the calibration was performed by electrical simulation or measurement rather than by the realisation or measurement of physical temperatures. The following sentence may be added to the certificate as appropriate: “The calibration of the

indicator was performed by sensor simulation using electrical standards only” or “The calibration of the simulator was performed using electrical measurement standards only”.

- 6.3 The standard reference tables used to convert the electrical signals to temperature values together with their reference and version numbers should be stated on the certificate.
- 6.4 In the case of instruments that can measure or simulate several different types of temperature sensors, the certificate should give a clear identification of the sensor types covered by the calibration. The number of sensor types covered by the calibration and the range of temperature over which each sensor type is calibrated should be agreed in advance with the customer.
- 6.5 For instruments which have a selectable CJC feature, calibration results may be given for either configuration of the instrument (i.e. either with the CJC feature enabled or with the feature disabled) or for both configurations. The configuration corresponding to the calibration results must be clearly stated. The calibration uncertainties quoted on the certificate will differ depending upon the CJC configuration used. For example, the following sentences may be added "Calibration results given were determined with the internal cold junction compensation enabled. The calibration uncertainty delivered takes into account components arising from the simulation procedure used to calibrate the temperature indicator” or "Calibration results given were determined with internal cold junction compensation disabled and are valid only when the temperature indicator is used with an external cold junction compensation system.”

## APPENDIX A

### Example of an uncertainty budget

#### Indicators intended for use with type S thermocouples with cold junction compensation

##### A1 MEASUREMENT PROCEDURE

The temperature indicator under test is fitted with a cold junction compensation facility. The calibration procedure used follows the method given in chapter 4, Fig. 3. The mV source is within its calibration period and previous calibrations have shown that its manufacturer's published accuracy specification may be relied upon.

The reference thermocouple wires used for the external cold junction compensation have been calibrated over the temperature range from 18 °C to 40 °C. The ambient temperature registered during the calibration of the temperature indicator was 23 °C ± 1 °C. The temperature indicator under test is for use with type S thermocouple sensors and has a digital display with a resolution of 0.1 °C.

##### A2 MEASUREMENT RESULTS

Temperature of calibration	Equivalent mV source setting (*)	Indication of temperature indicator
1000 °C	9586,2 μV	999,8 °C

(\*) The equivalent mV source setting is determined using the standard reference table corresponding to the type S thermocouple at the temperature of calibration. The emf equivalent is corrected to take into account the standard thermocouple wires correction at the temperature of the indicator's terminals.

##### A3 MODEL OF MEASUREMENT

The quantity of interest in the calibration is the correction  $c$  to apply to the indication ( $t_i$ ) on the indicator's display when the measuring junction of a standardised thermocouple (whose reference junction is connected at the input terminals of the indicator) is at the temperature of calibration  $t'$ .

$$c = t' - (t_i + \delta t_i) \quad (1)$$

where  $\delta t_i$  is a possible deviation due to the finite resolution of the temperature indicator under test.

Such a standardised thermocouple will generate an emf at the input terminals of the indicator of:

$$V = E(0\text{ °C}, t') - E(0\text{ °C}, t'') \quad (2)$$

where  $t''$  is the temperature of the indicator's terminals and  $E$  represents the emf values given in the standardised tables for temperatures  $t'$  and  $t''$ .

In the present calibration, we replace the thermocouple input by the emf produced by the millivolt source and reference junction device. Thus we have:

$$V = V_X + \delta V_{X2} + \delta V_{X3} + \delta V_P - [E(0^\circ\text{C}, t'') + \delta E_{c1}(0^\circ\text{C}, t'') + \delta E_{c2}(0^\circ\text{C}, t'')] + \delta t_{T3} \cdot S_0 \quad (3)$$

where

$V_X$  is the emf delivered by the mV source at a setting X;

$\delta V_{X2}$  is the correction to the output of the mV source at the setting X as determined at its last calibration;

$\delta V_{X3}$  is the correction to the output of the mV source at the setting X due to influence factors such as temporal drift, ambient temperature and power supply variations;

$\delta V_P$  is the correction due to parasitic voltages in the measuring circuit (thermoelectric, common mode, magnetic pickup);

$E(0^\circ\text{C}, t'')$  is the equivalent emf according to the reference table at the temperature  $t''$ .

$\delta E_{c1}(0^\circ\text{C}, t'')$  is the deviation of the thermocouple wires at temperature  $t''$  as determined at its last calibration;

$\delta E_{c2}(0^\circ\text{C}, t'')$  is the deviation to the thermocouple wires due to drift since its last calibration;

$\delta t_{T3}$  is the deviation from  $0^\circ\text{C}$  of the temperature of the reference cold junction;

$S_0$  is the Seebeck coefficient for type S thermocouple at  $0^\circ\text{C}$ .

Equating (2) and (3) we find the formula for the emf  $E(0^\circ\text{C}, t')$ .

$$E(0^\circ\text{C}, t') = V_X + \delta V_{X2} + \delta V_{X3} + \delta V_P - [\delta E_{c1}(0^\circ\text{C}, t'') + \delta E_{c2}(0^\circ\text{C}, t'')] + \delta t_{T3} \cdot S_0 \quad (4)$$

$$t' = P[E(0^\circ\text{C}, t')] = P[V_X + \delta V_{X2} + \delta V_{X3} + \delta V_P - [\delta E_{c1}(0^\circ\text{C}, t'') + \delta E_{c2}(0^\circ\text{C}, t'')] + \delta t_{T3} \cdot S_0]$$

$$\approx P(V_X) + [\delta V_{X2} - \delta E_{c1}(0^\circ\text{C}, t'') + \delta V_{X3} + \delta V_P - \delta E_{c2}(0^\circ\text{C}, t'') + \delta t_{T3} \cdot S_0] / S_{1000} \quad (5)$$

Finally substituting for  $t'$  in (1), we find the formula for the measured quantity ( $c$ ) in terms of the various input quantities.

$$c = P(V_X) + [\delta V_{X2} - \delta E_{c1}(0^\circ\text{C}, t'') + \delta V_{X3} + \delta V_P - \delta E_{c2}(0^\circ\text{C}, t'') - \delta t_{T3} \cdot S_0] / S_{1000} - (t_i + \delta t_i)$$

where

$P$  is the inverse reference function from IEC 584 for type S thermocouples;

$P(V_X)$  is the equivalent temperature according the standard reference table to the emf delivered by the mV source at a setting X;

$\delta V_{X2}$  is the correction to the mV source output determined at its last calibration;

$\delta V_{X3}$  is the correction to the output of the mV source at the setting X due to influence factors such as temporal drift, ambient temperature and power supply variations;

$\delta E_{c1}(0^\circ\text{C}, t'')$  is the deviation of the thermocouple wires from the standardised value at a temperature  $t''$  as determined at the last calibration;

$\delta V_P$  is the correction due to parasitic voltages in the measuring circuit (thermoelectric, common mode, magnetic pickup);

$S_{1000}$  is the Seebeck coefficient of a standardised type S thermocouple at 1000 °C;

$\delta E_{c2}(0\text{ °C}, t')$  is the deviation to the thermocouple wires due to drift since its last calibration;

$\delta t_{T3}$  is the deviation from 0 °C from the temperature of the reference cold junction;

$S_0$  is the Seebeck coefficient of the reference cold junction at 0 °C;

$t_i$  is the indication on the indicator's display;

$\delta t_i$  is a possible deviation due to the finite resolution of the temperature indicator under test;

The sensitivity (Seebeck coefficient ) of a type S thermocouple is:

$t / \text{°C}$	$S_t / \mu\text{V} \cdot \text{°C}^{-1}$
0	$S_0 = 5,4$
30 ( $t'$ )	$S_{30} = 6,0$
1000 ( $t'$ )	$S_{1000} = 11,5$

#### A4 UNCERTAINTY CONTRIBUTIONS

**Output of mV source ( $V_x$ ):** The output of the mV source is taken to be equal to its setting within the limits determined by the resolution of the setting. Since the mV source has a resolution of 1  $\mu\text{V}$ , these limits are  $\pm 0,5 \mu\text{V}$ , corresponding to a standard uncertainty of 0.29  $\mu\text{V}$ .

**Calibration of mV source ( $\delta V_{x2}$ ):** The correction of the mV source and its associated uncertainty associated are taken from the calibration certificate of the mV source. The correction is 0  $\mu\text{V}$  and the expanded uncertainty with a coverage factor  $k=2$  is  $\pm 1 \mu\text{V}$ . The corresponding standard uncertainty is  $\pm 0,5 \mu\text{V}$ . Former calibrations have proven that the drift of the mV source is small compared to this uncertainty and thus can be neglected.

**Influence factors ( $\delta V_{x3}$ ):** Separate values are not available for the corrections due to the various influence factors which affect the output of the mV source, but an overall correction with corresponding limits may be obtained from the manufacturers published accuracy specification for the mV source. The correction is therefore taken to be zero with limits given by this specification at the setting S, i.e.  $\pm 3 \mu\text{V}$ . The corresponding standard uncertainty is 1,73  $\mu\text{V}$ .

**Parasitic voltages ( $\delta V_P$ ):** The correction due to parasitic voltages in the measuring circuit is taken to be 0,0  $\mu\text{V}$  with limits of  $\pm 2 \mu\text{V}$ . The corresponding standard uncertainty is 1,15  $\mu\text{V}$ .

**Calibration of reference thermocouple wires ( $\delta E_{c1}(0\text{ °C}, t')$ ):** The emf generated by the reference thermocouple wires will be that corresponding to the temperature at the input terminals of the temperature indicator. This temperature is not measured separately, but is (for this particular case) assumed to be within the limits of 23 °C to 30 °C. The emf value (before

correction) will be within the range of 131  $\mu\text{V}$  to 173  $\mu\text{V}$ . The deviation of the reference thermocouple wires output from the standardised value in this temperature range is given in its calibration certificate as -1,8  $\mu\text{V}$  (-0,3  $^{\circ}\text{C}$ ) with an expanded uncertainty ( $k = 2$ ) of 1,5  $\mu\text{V}$  (0,25  $^{\circ}\text{C}$ ).

**Drift of the reference thermocouple wires ( $\delta E_{c2}(0^{\circ}\text{C}, t'')$ ):** The calibration history of the reference thermocouple wires shows the drift of the thermocouple's correction is 0,0  $^{\circ}\text{C}$  within limits of  $\pm 0,6 \mu\text{V}$  ( $\pm 0,1^{\circ}\text{C}$ ). The corresponding standard uncertainty is 0,34  $\mu\text{V}$  (0,058  $^{\circ}$ ).

**Cold junction temperature ( $\delta t_{T3}$ ):** Since the reference junction is maintained at the ice point, the standard uncertainty is taken to be 0,03  $^{\circ}\text{C}$ .

**Finite resolution of indicator under test ( $\delta t_i$ ):** The finite resolution of the temperature indicator introduces an uncertainty component. Since the least significant digit of the indicator is 0,1  $^{\circ}\text{C}$ , the limit is equivalent to  $\pm 0,05^{\circ}\text{C}$ . The uncertainty contribution is 0,029  $^{\circ}\text{C}$ .

**Indication on the indicator's display ( $t_i$ ):** Because of the limited resolution of the temperature indicator, no scatter in the indicated value was observed. The uncertainty contribution is not significant according the resolution contribution.

**Correlation:** None of the input quantities are considered to be correlated to any significant extent.

## A5 UNCERTAINTY BUDGET

Quantity	Symbol	Estimate	Standard Uncertainty	Probability distribution	Sensitivity Coefficient	Uncertainty Contribution
mV source output	$V_x$	9586,2 $\mu\text{V}$	0,29 $\mu\text{V}$	rectangular	$(11,5 \mu\text{V}\cdot^{\circ}\text{C}^{-1})^{-1}$	0,025 $^{\circ}\text{C}$
Calibration of mV source	$\delta V_{x2}$	0,0 $\mu\text{V}$	0,50 $\mu\text{V}$	normal	$(11,5 \mu\text{V}\cdot^{\circ}\text{C}^{-1})^{-1}$	0,044 $^{\circ}\text{C}$
Influence factors	$\delta V_{x3}$	0,0 $\mu\text{V}$	1,73 $\mu\text{V}$	rectangular	$(11,5 \mu\text{V}\cdot^{\circ}\text{C}^{-1})^{-1}$	0,151 $^{\circ}\text{C}$
Parasitic voltages	$\delta V_p$	0,0 $\mu\text{V}$	1,15 $\mu\text{V}$	rectangular	$(11,5 \mu\text{V}\cdot^{\circ}\text{C}^{-1})^{-1}$	0,10 $^{\circ}\text{C}$
Calibration of thermocouple wires	$\delta E_{c1}(0^{\circ}\text{C}, t'')$	-1,8 $\mu\text{V}$	0,75 $\mu\text{V}$	normal	$(11,5 \mu\text{V}\cdot^{\circ}\text{C}^{-1})^{-1}$	0,065 $^{\circ}\text{C}$
Drift of thermocouple wires	$\delta E_{c2}(0^{\circ}\text{C}, t'')$	0,0 $\mu\text{V}$	0,34 $\mu\text{V}$	rectangular	$(11,5 \mu\text{V}\cdot^{\circ}\text{C}^{-1})^{-1}$	0,030 $^{\circ}\text{C}$
Deviation of ice point	$\delta t_{T3}$	0,00 $^{\circ}\text{C}$	0,03 $^{\circ}\text{C}$	normal	0,469	0,015 $^{\circ}\text{C}$
Resolution of UUT	$\delta t_i$	0,00 $^{\circ}\text{C}$	0,029 $^{\circ}\text{C}$	rectangular	1	0,029 $^{\circ}\text{C}$
Indication of the simulator	$t_i$	999,8 $^{\circ}\text{C}$	insignificant	normal	1	insignificant
Correction to apply to indication of temperature indicator	<b>c</b>	<b>0,2 <math>^{\circ}\text{C}</math></b>				<b>0,204 <math>^{\circ}\text{C}</math></b>

## **A6 STATEMENT OF CALIBRATION RESULT**

The correction of the temperature indicator at a reading of 999,8 °C and with the internal cold junction compensation enabled is  $(+0,2 \pm 0,4)$  °C.

This correction has been determined by simulation using electrical standards only.

The reported uncertainty is stated as a standard uncertainty of measurement multiplied by a coverage factor  $k = 2$ , which, for a normal probability distribution, corresponds to a coverage probability of approximately 95 %.