

Drilling mud optimisation for enhanced time-dependent wellbore stability

Wellbore collapse is a common problem in the drilling industry and causes drilling delays and expenses running into hundreds of millions of dollars. A borehole collapses when the effective stresses on the wellbore wall exceed the rock strength. Depending on relative magnitudes of in-situ stresses and mud pressure inside the well, the wellbore may collapse by different modes. These failures are traditionally attempted to prevent by optimising the mud density. This project focuses beyond this conventional static model of mud optimisation for wellbore stability and enhances our capability to consider the time-dependent interactions (e.g. capillary and chemical potential effects) of mud with formations to assess the time-dependent wellbore stability. It is now possible to optimise both the mud density and chemical composition to enhance time-dependent wellbore stability.

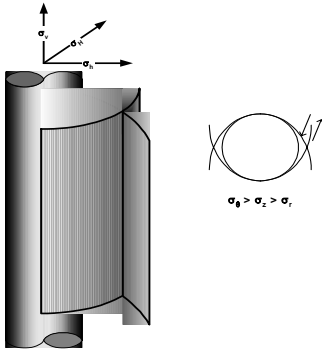

Shear failure of a borehole

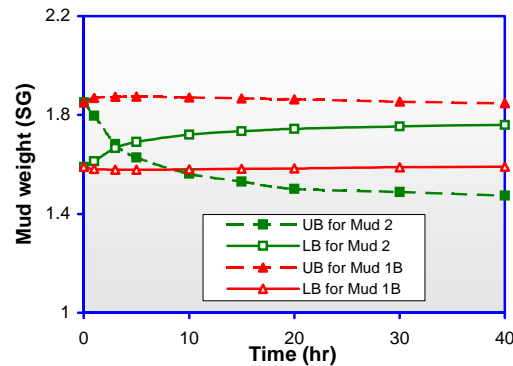

Mud window closes (borehole failure) in 3 hours, but appropriate salt concentration widens the window.

Selected Publications:

- Rahman, M.K., Chen, Z. and Rahman, S.S., 'Modeling Time-Dependent Pore Pressure Due to Capillary and Chemical Potential Effects and Resulting Wellbore Stability in Shales', *Journal of Energy Resources Technology*, Vol. 125, No. 3, pp.169-176, 2003.
- Rahman, M.K., Chen, Z. and Rahman, S.S., 'Pore Pressure Change due to Mud Penetration and its Time-Dependent Effects on Wellbore Stability in Shales: Experimental and Analytical Investigations', *ASME ETCE/OMAE joint Conference*, New Orleans, LA, Feb.14-17, 2000.
- Rahman, M.K., Naseby, D. and Rahman, S.S., 'Borehole Collapse Analysis Incorporating Time-dependent Pore Pressure Due to Mud Penetration in Shales', *Journal of Petroleum Science & Engineering*, Vol.28, No.1-2, pp.13-31, 2000.