

Soil Classification Chart

Ground anchors are designed for different soil classifications: longer models for loose soils, shorter models for harder soils. Prior to installing any ground anchor model, the soil must be tested (with a Soil Test Probe) in order to match approved ground anchor model with site soil class.

WARNING: Before ground anchor installation, determine that the anchor locations around home will not be close to any underground electrical cables, water lines or sewer piping. Failure to determine the location of electrical cables may result in serious personal injury.

Soil Test Probe

The Soil Test Probe is used to determine the soil conditions below the surface near the anchor's helix. Using the Soil Test Probe will ensure maximum anchor holding strength by indicating the proper anchor model for each soil condition.

Using the chart provided, a probe reading can be converted to the recommended anchor for every soil condition.

Instructions

- Place probe tip into ground where you intend to place the anchor. Using a 15/16" hex socket with a ratchet or breaker bar, rotate the probe in a clockwise direction. (An electric drive machine with an adaptor head may also be used)
- Drive (rotate) the torque probe into the soil until reaching a depth equal to the length of the anchor being installed.
- To determine the soil classification:
 - Place wrench adaptor onto torque wrench.
 - Insert hex portion of wrench adaptor onto the earth probe.
 - Support probe shaft with one hand, while rotating probe steadily with the wrench. (Do not exceed 600 in. lbs.)
 - Read the torque wrench while rotating probe clockwise.
 - Use the soil classification chart to cross reference probe readings. Color codes match those printed on Tie Down's torque probe.
- If probe reading does not match the anchor for that depth, rotate probe to next anchor depth and check reading. Continue until reading on probe matches anchor length for depth of reading.
- To remove probe, use wrench or electric drive machine in reverse (counter clockwise).

Soil Class	Test Value (in. lbs.)	Soil Description
1	N/A	Sound hard rock.
2	550 +	Very dense and/or cemented sands, coarse gravel, cobbles, preloaded silts, clays and coral.
3	350 to 550	Medium dense coarse sands sandy gravels very stiff silts and clays.
4a	275 to 350	Loose to medium dense sands, firm to stiff clays and silts, alluvial fill.
4b	175* to 275	Loose sands, firm clays and silts, alluvial fill.

* Below 175 in. lbs., a professional engineer should be consulted

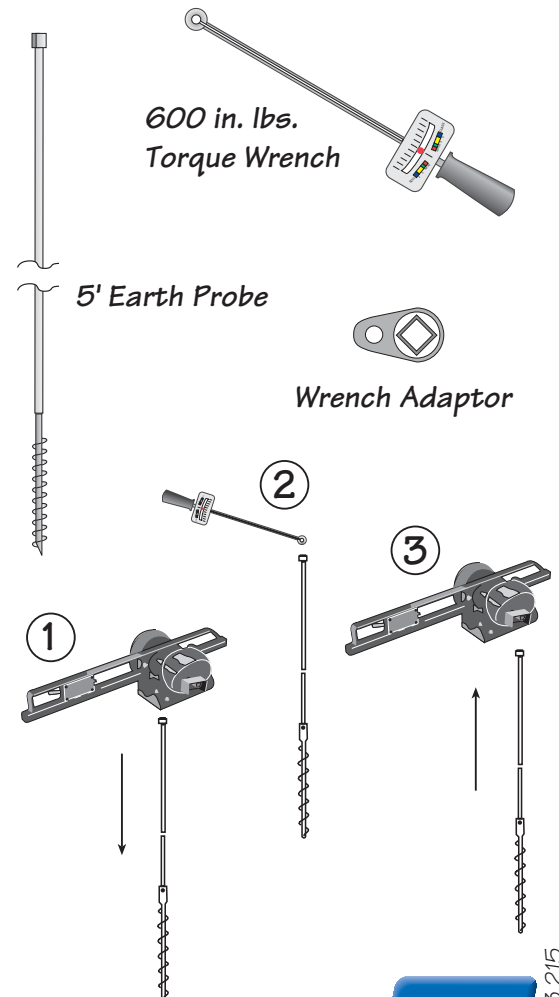

NOTE: Each State, County or Municipality may require a specific anchor from the groups shown for each soil classification. Check local and State regulations first.

Anchor Chart

Soil Class	Test Value (in. lbs.)	Recommended Anchor / Stabilizers	TDE Part Number
1	N/A	Cross Drive Rock Anchor	59110 & 59111
2 Blue	550 lbs +	30" X 5/8" rod / 2 - 4" helix 30" X 3/4" rod / 2 - 4" helix All anchors above must use one of the following: 12" Stabilizer Plate Quik-Set Stabilization Plate	59090 59095 & 59079 59292 59291
3 Yellow	350 to 550 lbs.	48" X 5/8" rod / 1 - 6" helix 48" X 3/4" rod / 1 - 6" helix 36" X 3/4" rod / 1 - 6" helix & 1 - 4" helix The anchors above must use one of the following: 12" Stabilizer Plate Quik-Set Stabilization Plate 30" X 5/8" rod / 2 - 4" helix Deepset 36" X 3/4" rod / 4" & 6" helix Deepset	59080 & 59081 59085 & 59094 59250 59292 59291 59091 59092
4a Green	275 to 350 lbs.	48" X 5/8" rod / 1 - 6" helix 48" X 3/4" rod / 1 - 6" helix 36" X 3/4" rod / 1 - 6" helix & 1 - 4" helix The anchors above must use one of the following: 12" Stabilizer Plate Quik-Set Stabilization Plate ABS Stabilization Plate (Florida Only) 36" X 3/4" rod / 4" & 6" helix Deepset 50" X 3/4" rod / 4" & 6" helix Deepset	59080 & 59081 59085 & 59094 59250 59292 59291 59293 59092 59093
4b Red	175 to 275 lbs.	60" X 3/4" rod / 1 - 7" helix The anchor above must use one of the following: 17 -1/2" Stabilizer Plate ABS Stabilization Plate	59099 59286 59293

NOTE: Each State, County or Municipality may require a specific anchor from the groups shown for each soil classification. Check local and State regulations first.