

ARGO NAVIS

Mainland Robotics Team

Students: Natasha Barrett
Jeffrey Ciabattoni
Brittany Donoho
Christian Kimmey
Meriah Voight

Mentors: Robert Kershaw
Tony Ciabattoni
Patrick Engelhardt
Mike Norris
Ken Rose

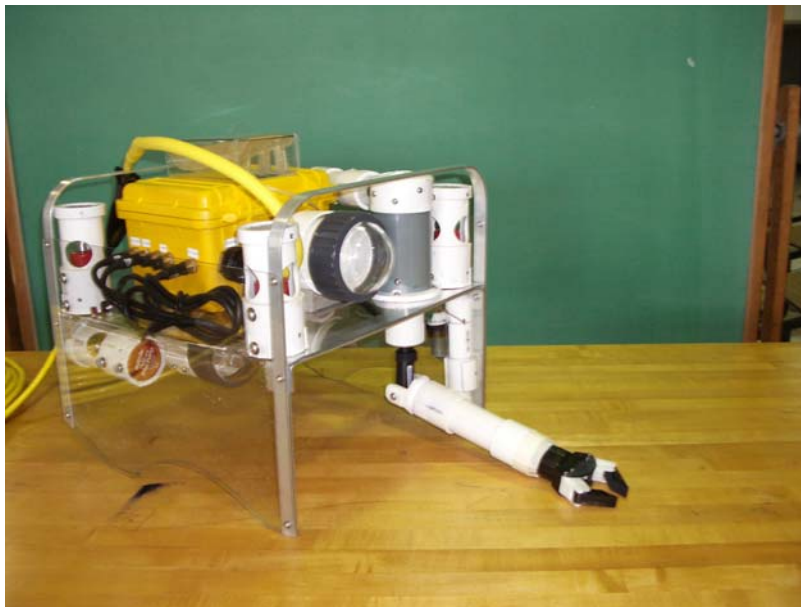

Table Of Contents

Team Introduction -----	3
Abstract -----	4
What is in a Name? -----	4
Budget Report -----	5
Robot Pictures -----	7
Schematics	
a) Power Distribution Layout -----	9
b) Control System Layout -----	10
c) Video System Layout -----	11
Design Rationale -----	12
Challenge -----	14
Trouble Shooting -----	14
Lessons -----	15
Future Improvements -----	15
Essay: Mission Control -----	16
Acknowledgements -----	18

Mainland Robotics Team 2004 – 2005



Far back- Pat Englehardt; back row- Brittany Donoho, Jeff Ciabattoni, Natasha Barrett, Tony Ciabattoni; front row- Christian Kimmey, Robert Kershaw; not pictured- Meriah Voight, Mike Norris, Ken Rose.

Students (school, grade, age, career):

Natasha Barrett – (Boris)

- Texas City High School, Senior, 17, English Literature

Jeffrey Ciabattoni – (Friar Jeff)

- Texas City High School, Sophomore, 16, Engineering

Brittany Donoho – (Captain Crunch)

- La Marque High School, College of the Mainland, 17, Aeronautical Engineer

Christian Kimmey – (Hazard)

- Texas City High School, Sophomore, 15, Video Game Designing

Meriah Voight – (Boss)

- College of the Mainland, Freshman, 19, Bachelor of Science in Mathematics

Mentors:

Robert Kershaw (Mr. Spacely) - BP, Analyzer Technician

Tony Ciabattoni - BP, Machinist

Patrick Engelhardt (Little John) - La Marque High School, Chemistry Teacher

Mike Norris - NASA, International Space Station Communications Engineer

Ken Rose - BP, Supervisor of Turbine Control Group

Abstract

This is the third year of MATE competition for the Mainland Robotics Team, but the first year in the Explorer class. This is a challenge that our experienced team looked forward to tackling. There were several additional obstacles: team's status changed from school sponsored to private, there was an upgrade in power this year, and time/manpower was significantly lessened. In addition, most of the components on the ROV are custom-made, and there was very little prototyping done before final assembly.

The Argo Navis ROV is designed to complete several objectives for a space expedition to Jupiter's moon Europa, such as re-establishing communication between a malfunctioned science package and ground control on Earth. In addition, the ROV needs to retrieve data probes located inside the science package. Finally, the ROV will take a liquid sample and temperature reading from a venting crevice. All of the above tasks have to be completed at a depth of 13.88 meters below the water's surface with no other insight from above except for what is fed back from the ROV.

Some of the unique features of this ROV to successfully complete these objectives include:

- a minimal light weight Lexan frame providing high visibility
- a precise thermocouple for temperature measurement
- a preprogrammed fluid collection system for maximum accuracy
- a three axis motor operated arm for probe collection and connector placement
- thrusters capable of pitch control to allow for optimum navigation
- a neutrally buoyant twelve millimeter diameter Video Ray tether for lower drag and better maneuverability

This report contains more details about these features.

What is in a Name?

Argo Navis received its title from an ancient Greek constellation that was named after the ship built and used by Jason and the Argonauts in their quest for the Golden Fleece. Today this constellation has been broken into six separate but smaller constellations: Puppis, Vela, Pyxis, Carina, Volans, and Columba. Argo Navis is below the 75th degree South Latitude line and appears as if it is skimming the southern horizon on its westward journey. It can be found by locating Canis Major and moving east of the triangle that makes up its hind legs.

This name was chosen and voted on by the members of our team after looking through a few astrology books and an internet search. The basis of the decision rested on the Argo being a legendary ship and Argo Navis being a constellation. One pertained to the sea and the other to the sky, therefore encompassing our goals of an underwater ROV that completes missions associated with space.

Resource: <http://www.astro.wisc.edu/~dolan/constellations/extra/ArgoNavis.html>

Mainland Robotics Team

2005 MATE / MTS ROV Student Competition

Budget/Expense Report

School Name:		College of the Mainland Foundation / LaMarque High School / Texas City High School			Period	
Instructor/Sponsor:		Robert Kershaw			From:	8/1/2004
					To:	5/26/2005
Date	Dep / Exp	Description	Notes	Amount	Balance	
11/1/2004		Beginning Balance			\$0.00	
1/27/2004	Dep	Texas City High School (donated Sea View cameras)	500.00			
7/27/2004	Dep	BP Time Matching Grant (check)	1300.00			
1/13/2005	Dep	BP Texas City Site Grant (check)	1000.00			
1/18/2005	Dep	MATE Material stipent (check)	100.00			
3/7/2005	Dep	Sea Con Brantner (material donation of WET-Mate subsea connectors)	700.00			
3/12/2005	Dep	Texas City ISD Technology Dept (donated bilge pumps and speed controllers)	980.00			
4/3/2005	Dep	BP Turbine Control Group (donated power supply and converters)	1250.00			
6/17/2005	Dep	MATE National travel stipent (one hotel room plus tax)	338.00			
	Memo	Income and donation total	6168.00	\$6,168.00	\$6,168.00	
	Memo	Control System				
1/1/2005	Exp	Rubbermaid Cart	-110.00			
	Exp	12 vdc Battery Power Supply	-100.00			
	Exp	Emerson 25 cm TV/VCR (donation from 2004 contest)	0.00			
3/1/2005	Exp	Model 1600 Pelican box	-110.00			
	Exp	Cosel 120v AC-48v DC power converter	-500.00			
	Exp	15 amp marine circuit breakers (2)	-60.00			
	Exp	Arcade style joysticks (2)	-30.00			
	Exp	100K potentiometers (3)	-5.50			
	Exp	Toggle switches (2)	-6.00			
	Exp	Laptop computer (borrowed)	0.00			
	Exp	Innovation First (IFI) Operator Interface	-90.00			
	Exp	Joystick (2)	-30.00			
	Exp	Video Ray tether cable (36.58 M)	-120.00			
	Exp	Sea Con Brantner WET-Mate subsea connectors (14)	-700.00			
	Exp	Model 1300 Pelican box	-42.00			
	Exp	Cosel 48 vdc power converters (3- 24v, 12v, 3v)	-750.00			
	Exp	Fuse blocks (3)	-18.00			
	Exp	Fuses (20)	-5.00			
	Exp	IFI Robot Controller	-210.00			
	Exp	IFI Victor 48hv speed controllers (4)	-800.00			
	Exp	IFI SPIKE Relay	-15.00			
	Exp	Novak 4.8 v speed controller (3)	-212.00			
	Exp	Miscellaneous electrical equipment (wire, terminals, tape, etc.)	-50.00			
	Memo	Control system total	-3963.50	-\$3,963.50	\$2,204.50	

Mainland Robotics Team

2005 MATE / MTS ROV Student Competition

Budget/Expense Report

School Name:		College of the Mainland Foundation / LaMarque High School / Texas City High School			Period	
Instructor/Sponsor:		Robert Kershaw			From:	8/1/2004
					To:	5/26/2005
Date	Dep / Exp	Description	Notes	Amount	Balance	
		Balance from previous page			\$2,204.50	
	Memo	ROV				
	Memo	Body				
	Exp	RULE 4160 LPH Bilge Pumps (6)	-180.00			
	Exp	Lexan Sheet, 61 cm x 91 cm	-80.00			
	Exp	Octura 1250 Propellers (6)	-12.50			
	Exp	PVC material for thrusters (18)	-10.80			
	Memo	Camera				
	Exp	Sea View Camera (2)	-500.00			
	Exp	Futaba S2003 servo (2)	-30.00			
	Exp	Video Ray 10 mm dome lens (2)	-10.00			
	Exp	2 inch PVC union (2)	-20.00			
	Exp	PVC Female adapter and coupling (2)	-5.00			
	Memo	Collector				
	Exp	Type K thermocouple wire (donated)	0.00			
	Exp	Windshield Washer Pump	-4.00			
	Exp	500ml Blood Bag (donated)	0.00			
	Exp	PVC pieces (5)	-2.50			
	Memo	Arm				
	Exp	2.4v Battery powered screwdrivers (3)	-40.00			
	Exp	90 degree Dremmel gear heads (2)	-40.00			
	Exp	10 cm Nylon stock (donated)	0.00			
	Exp	Joint Radial Oil Seals (3)	0.00			
	Exp	PVC pieces (12)	-10.00			
	Memo	Other				
	Exp	Miscellaneous aluminum material	-40.00			
	Exp	Miscellaneous stainless material (fasteners, fittings, etc.)	<u>-30.00</u>			
	Memo	ROV total	-1014.80	-\$1,014.80	\$1,189.70	
6/19/2005	Exp	National Event Expense (2 hotel rooms)		-\$676.00	\$513.70	
	Memo	Ending 2005 Balance		\$0.00	\$513.70	

Robot Pictures

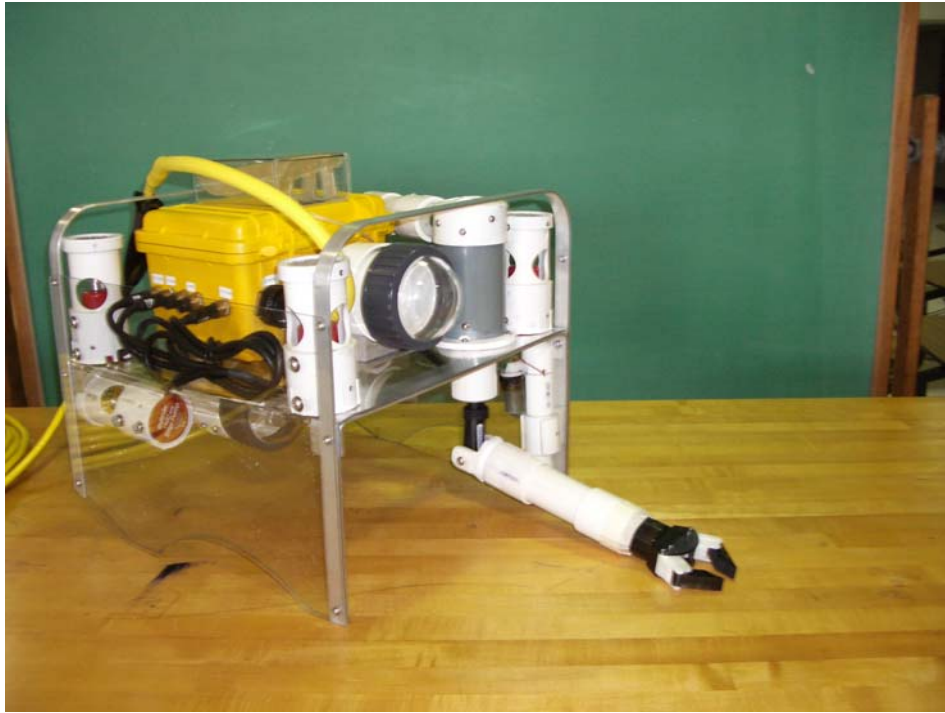

Argo Navis Front View with Arm Extended



Argo Navis Rear View, Camera 2 on bottom

Robot Pictures



Argo Navis Pilot Station

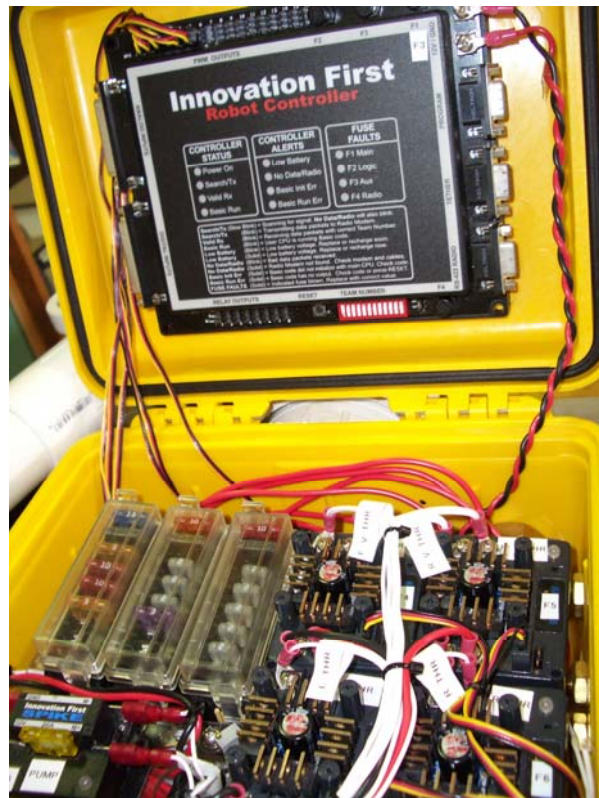

Argo Navis ROV Control Box

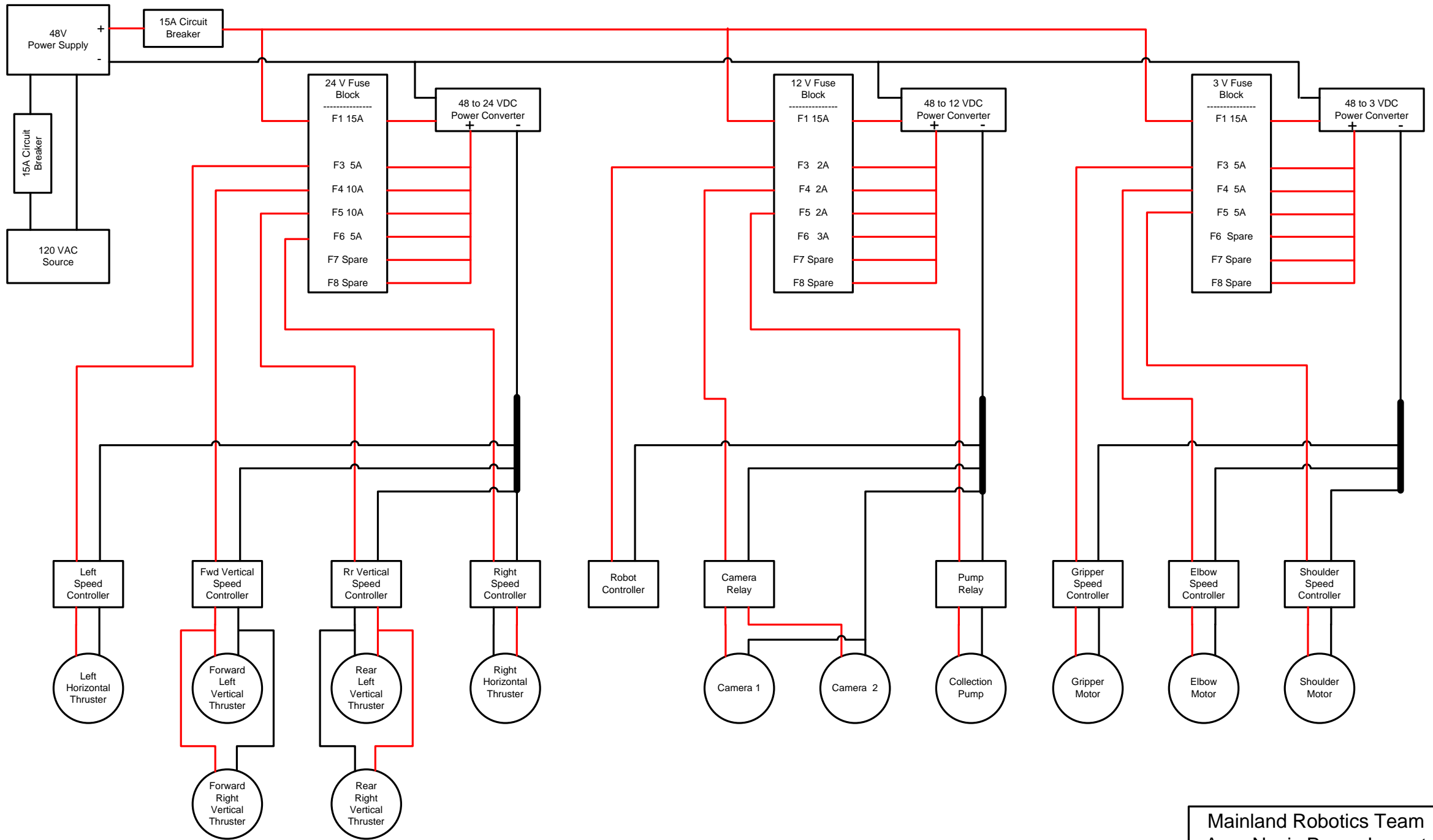

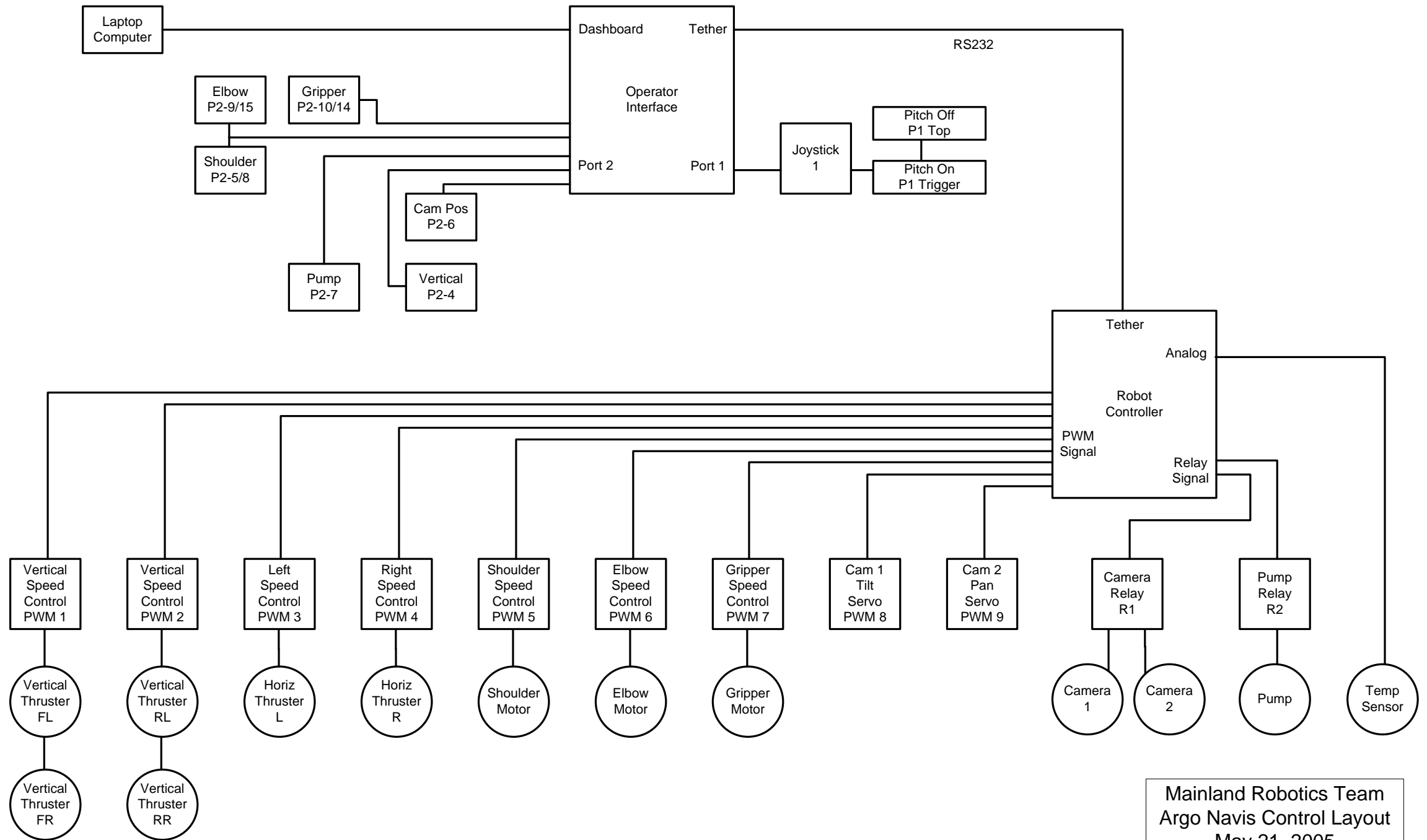

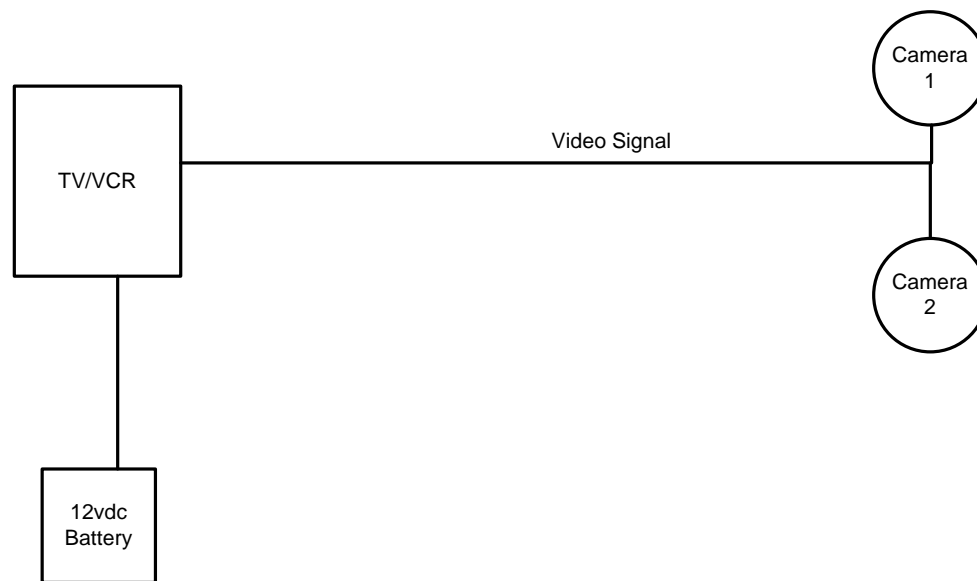

Design Rationale

Structural Components

- a) frame
- b) thrusters
- c) cameras
- d) tether
- e) controls- onboard and off board
- f) manipulator
- g) fluid collector

Task Components

- manipulator
- fluid collection device
- Thermocouple

Structural Components

- a) This ROV has a Lexan shell with aluminum plates for structural support. Lexan was used because it allows us to see through it for maximum visibility. Also, it is light weight and strong, allowing other components to be attached to it. There is also a Lexan shelf in order to mount the onboard control box.
- b) There are six 4160 LPH, 24 volt bilge pump motors, two horizontal and four vertical on this robot. Each motor draws, on average, 2.4 amps and provides 13.44 Newtons of force. The motor configuration is designed to implement pitch, allowing it to dive nose first if necessary. Being able to pitch will come in handy getting into tight places that wouldn't be possible normally. Texas City ISD's Technology Department donated all of the motors.
- c) There are two Sea View CSM-50 color cameras with sixty-eight degree view angles being used. Each camera runs off of twelve volts DC requiring minimal illumination, and has been attached to a servo. By doing this the cameras can now tilt or pan as needed. The primary work camera is capable of panning and has been placed to view the thermocouple collection device and the arm orientation. The secondary camera tilts and is able to view the arm's progress or openings above the robot, allowing us to navigate more easily. The cameras were also donated by Texas City ISD.
- d) The tether is twelve millimeters in diameter and neutrally buoyant. It contains two pairs of eighteen gauge wires, two pairs of twenty-eight gauge wires, and one pair of twenty-four gauge wire and will sustain a maximum of fifteen amps. This tether was chosen because its compact size will not hinder maneuverability and has fewer possibilities of snagging.
- e) Argo Navis has both onboard and on shore control system components both, of which, are contained in waterproof Pelican boxes. The onboard control system

was chosen because it allows for the small tether. This is a new control method making this design more challenging for the team.

- f) The ROV has a three axis motor operated arm consisting of three screwdriver motors and two ninety degree Dremmel tool heads. It has multiple movable fingers, an “elbow” (up and down movement), and a “shoulder” (rotating base). The battery powered screwdriver motors were reconfigured to run on a continuous power supply. Many of the parts had to be machined specifically, but due to the durability of the motors, these will withstand the mission’s stresses.
- g) A waterproofed windshield washer pump attached to a 6.5 millimeters in diameter stainless steel tube will be used to collect the liquid from the crevice and store it in a five hundred millimeter blood bag. Small electrical pumps were used because they draw very little current and require no air tubes, as pneumatics would. The steel tubing extends down a PVC shaft that has been belled out at the end, to guide it onto the crevice for liquid extraction. The blood bag is perfect for this application because it is very durable. Finally, a type K Alumel thermocouple has been placed inside the fluid collector’s tubing. This device was chosen because it is accurate in reading temperatures over a wide range from 3 degrees Kelvin to 1643 degrees Kelvin.

Task Components

Task 1: Re-establishing communication- this task will be accomplished by the ROV’s manipulator with guidance help from the top tilting camera viewing its orientation.

Task 2: Retrieving Data Probes- The arm will also accomplish this task and store the probes in a collector device located inside the robot.

Task 3: Collecting Fluid Sample- The collection device will pump the liquid to the collection bag placed on top of the onboard control box above the shelf. Tests show that in order for the pump to prime the bag had to be placed a good distance above the pump.

Task 4: Temperature Measurement- The thermocouple is an accurate, lightweight, and small device, a simple solution to accomplish this task. By making use of the Dashboard program on the laptop we will be able to view the temperature in tenths of a degree.

Challenge

Argo Navis has both an onboard and onshore control system because the tether being used is limited by the number of wires and allowable amperage. At maximum, only fifteen amps can be sent down the power wires without literally melting the insulation. Serious testing was done on each component before it was integrated into the system, making sure it fit both the amperage and voltage requirements. The heart of the control system is a 48 volt power supply that runs at a range of ten to fifteen amps.

Another challenge we had with the tether was the number of wires: two pairs of eighteen gauge wires, one pair of twenty four gauge wires, and two pair of twenty eight gauge wires. The eighteen gauge wires were ran parallel to each other and used for moving power down the tether. The single pair of twenty four gauge wires is reserved for camera feedback from the ROV to the television monitor on shore. The twenty eight gauge wires are used as communication between the IFI Operator Interface on land, and the Robot Controller on the robot. This posed a particularly difficult problem for us. The Communication system is designed to use nine pins, not four. We tested both parts to determine the minimum amount of pins necessary to operate the “brain.” The drawback to using fewer pins is that the Operator Interface usually derives power from the Robot Controller. With only four communication wires available, a separate power supply was required to run the Operator Interface.

Trouble Shooting

To make the best use of our time, the team divided into several different subgroups based on their specialties: body, manipulator, controls, and documentation. At the beginning of each meeting there was a discussion about what needed to be done for that day and the possible problems that might occur. Each person got to submit ideas which helped develop the best possible mechanism for the job. Also, at the end of the day, there was another discussion about what had taken place and the problems encountered. This allowed everyone to have at least the basic knowledge of what was happening. Many times at these meetings there were still problems that required solutions. In these cases, everyone would make note of the problem and do research in an attempt to derive a solution by the next meeting. Usually we would end up having to run experiments on several different parts to decide which one was the best to use. This method came in quite handy when we tried to develop an arm. First, we purchased a robotic kit arm, but it became apparent it wouldn't work. By that time the required three volt power supply had been purchased. So, when a new arm started being developed, we needed to locate motors that would run on three volts. Battery powered screwdriver motors fit this power supply, but if directly connected the motors, turned too fast for our needs. We conducted three different experiments before a device was found that effectively allowed us to control the motor speed: a twelve volt speed controller, a twelve volt relay, and a 4.8 volt micro speed controller. The twelve volt speed controller and relay didn't work because they require a minimum of six volts to operate. The onboard control system now uses three 4.8 volt micro speed controllers.

Lesson

In years past our ROV design was restricted by the primitive control systems we were using. The team saw that in order to give us free range on the design and efficiency of our actual robot, we had to design a container that was easily interchangeable.

The need for an efficient and multipurpose control box led us to this design. We are using a 23.8 cm * 18.4 cm * 15.5 cm Pelican Box for our onboard controls. It is a waterproof, structurally sound enclosure housing our onboard electronic system. Also, it allows fast and simple component connections while delivering the sufficient amount of power to each. Another and the most important reason why we are using a Pelican box is because it creates a reusable control system that allows future modifications if necessary. One thing we have learned while developing the box, was how to fit a complete control system into such a small space. In this box we have an IFI Robot Controller, three fuse panels, four IFI speed controllers, three DC to DC converters, one IFI relay, and three Novak speed controllers. We also had to risk the box's waterproof integrity by drilling multiple holes in the sides for the Seacon Wet-Mate cable bulkhead fittings. The box required precise measurements and the component placement had to be well thought out before hand.

Future Improvements

Two of the improvements we would like to make to our robot would be a fiber optics tether and onboard batteries. These changes would practically eliminate our tether making it even less likely to snag. This would also reduce the weight of the tether. The disadvantages would be that the batteries would increase our robot's overall weight, requiring more buoyancy and lift to maneuver. Also, we are unsure how the required technology to run such a tether, such as a converter, will affect our ROV's size and weight and consequently its maneuverability. Another improvement would be a more up-to-date version of the IFI Operator Interface. Our version is programmed in P-Basic, and limits the overall capabilities of the robot. The more modern versions are programmed in C-code, a language that allows more variables and therefore more design possibilities.

The final improvement we would like to make would be for aesthetic reasons. The robot would be more interesting and visually appealing if the controls were a car's steering column and gas pedals. Though appearance is important, it is the last issue our team feels needs to be covered. Therefore, we are satisfied with the look of our control station and ROV.

Mission Control

There has always been at least two parts to a successful robot: the robot itself and those that control it. These two sections also make up the skeleton for missions to space. The people who control manned space missions from Earth form a tight-knit group known as mission control. They are the nerve center and a key element of the space program, but their roles have changed as technology advanced. During the Mercury program in the 1950's, ground control was highly relied on. In fact the manual control systems on the spaceships served merely as back up if the need arose. During the Apollo program, some onboard control was required due to the longer distances and blockage by the moon, and the spacecraft started to become ever more self-reliant. Today, mission control plays the role as an extra set of eyes, analyzing the massive amount of data relayed back to Earth. They also help by aiding the crew on the Shuttle or International Space Station in whatever way deemed necessary. The United States has three active control rooms found at the Johnson Space Center in Houston, Texas, located in a recently built wing. Typically the Shuttle mission control room has about fifty people actually staffing it at one time with ties to thousands of support people around the world. The International Space Station usually has even less, with little more than twenty at most when extremely busy. When the crews are asleep usually only three to four people are on duty. Each room contains multiple computer consoles and a large front projection screen. All of the consoles are linked together by headsets and computer networks, for sharing information with each other as needed. Each console has been given a call sign that is an acronym for their area of responsibility. For instance, the primary communicator between the astronauts and ground control is the Capsule Communicator, better known as "CapCom" for short. The Flight Dynamics Officer (FDO) and the Flight Guidance Officer (GPO), with call signs "Fido" and "Guidance" respectively work together in conjunction to manage the onboard guidance systems to plan maneuvers and monitor flight trajectory. It takes several years of training, as well as, the time it takes to become degree qualified to work in mission control. You have to be one of the best in your particular field and also have very good communication and interpersonal skills. This allows you to be best prepared for any scenario and able to devise the best possible solution with your colleagues. It is rare for a problem to occur that only affects one of the controllers; usually it affects several if not all of the controllers in the room! You have to be able to communicate accurately with your teammates to collaborate a plan to solve the problem. Working in mission control is an honor that takes many years of learning, training, and unswerving dedication to achieve. There are many different careers employed in mission control outside of engineers. Doctors, lawyers, mathematicians to just name a few, aren't uncommon to be found on staff. It takes many different types of people with many different types of backgrounds to successfully accomplish the giant task of being mission control.



Resources:

NASA's High School Aerospace Scholars Home Web Page, Lesson 1
<http://aerospacescholars.jsc.nasa.gov/HAS/cirt/ss/1/7.cfm>

Links:

<http://spaceflight.nasa.gov/spacenews/releases/2000/j00-48.html>
<http://spaceflight.nasa.gov/shuttle/reference/fag/mcc.html>

Acknowledgements



<http://www.bp.com>

BP Texas City Site includes a petrochemical refinery. BPTCS provided grants through community action committees, employee time matching programs, and donated power supplies from the Turbine Control group.



http://www.marinetech.org/rov_competition

MATE education center provided material and travel stipends.



<http://www.seaconbrantner.com>

Sea Con Brantner manufactures subsea cable connectors. They provided WET-Mate connectors for all components.



<http://www.texascity.isd.tenet.edu>

Texas City High School provided a spacious work shop and storage area in addition to full pool access. Texas City ISD donated bilge pumps and speed controllers.