

**MODULE
MATHEMATICS SPM
CIRCLES**

1.

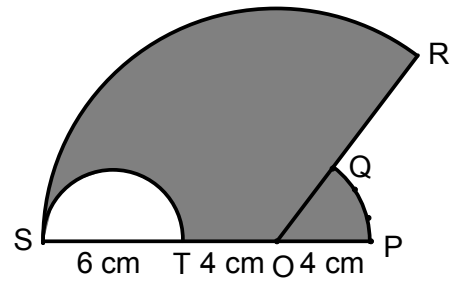

$\angle SOR = 120^\circ \quad \pi = 3.142$

- a) Perimeter of the whole diagram.
- b) Area of the shaded region.

2.

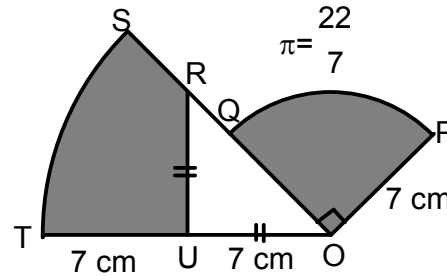

- a) Perimeter of the whole diagram.
- b) Area of the shaded region.

3.

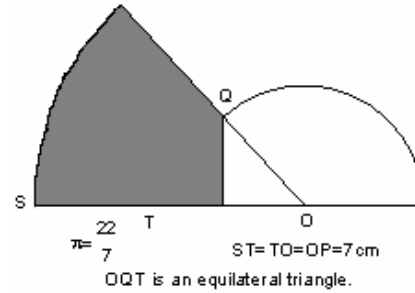

- a) Perimeter of the whole diagram.
- b) Area of the shaded region.

4.

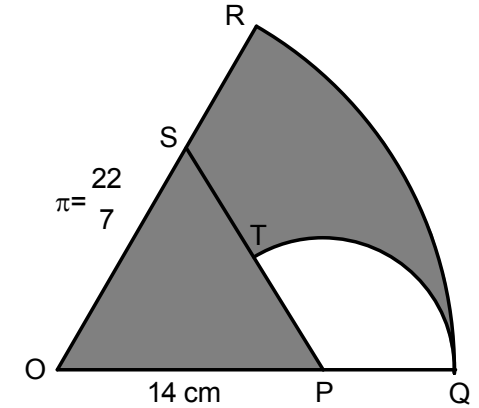

- T is the midpoint of SP.
SOP is an equilateral triangle of side 14 cm.
- a) Perimeter of the whole diagram.
 - b) Area of the shaded region.

5.

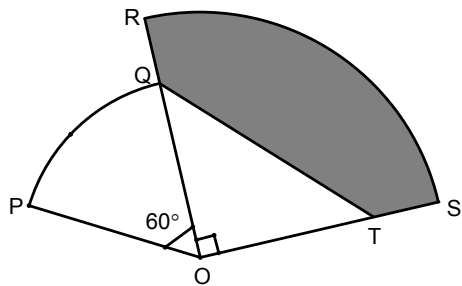

$RQ = ST = 7 \text{ cm}, PO = 14 \text{ cm}, \pi = \frac{22}{7}$

- Area of the shaded region
- Perimeter of the whole diagram.

6.

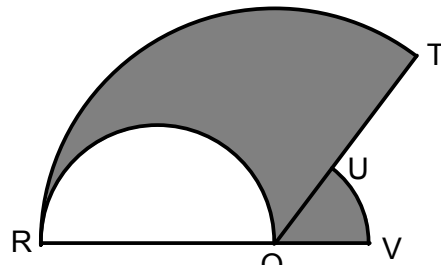

$\pi = \frac{22}{7}$ $RO = 20 \text{ cm}$
 $OV = 7 \text{ cm}$
 $\angle UOV = 60^\circ$

- Area of the shaded region
- Perimeter of the whole diagram.

7.

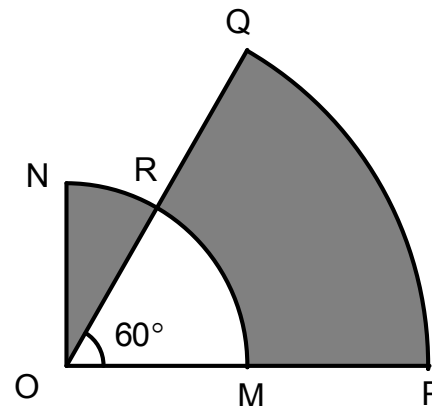

$OM = MP = 7 \text{ cm},$
 $\angle POQ = 60^\circ, \pi = \frac{22}{7}$

- Perimeter of the whole diagram.
- Area of the shaded region.

8.

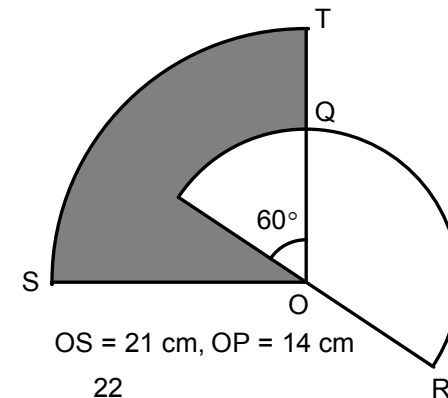

$OS = 21 \text{ cm}, OP = 14 \text{ cm}$
 $\pi = \frac{22}{7}$

- Area of the shaded region
- Perimeter of the whole diagram.

9.

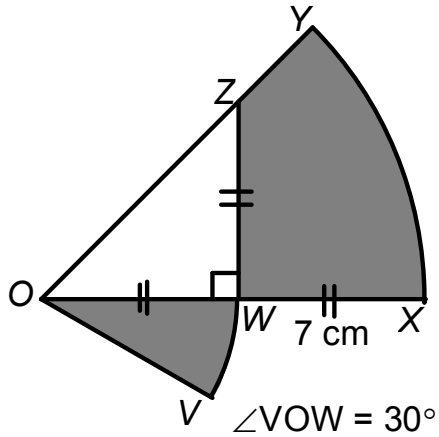

$$\pi = \frac{22}{7}$$

- Perimeter of the whole diagram.
- Area of the shaded region.

10.

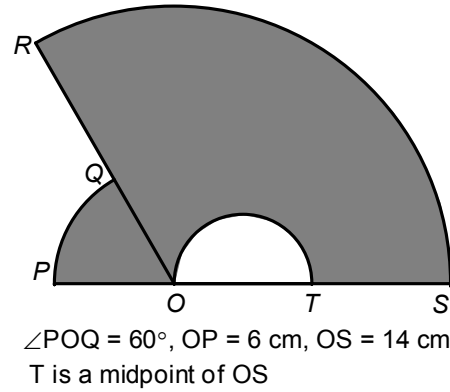

$$\pi = \frac{22}{7}$$

- Perimeter of the whole diagram.
- Area of the shaded region.

11.

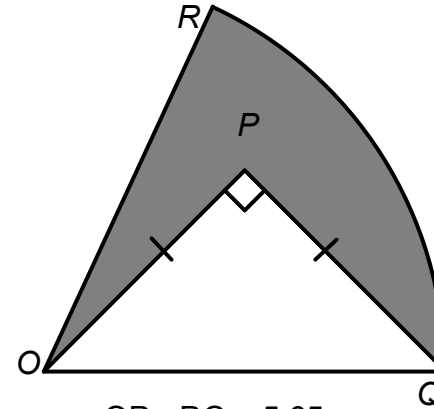

$$\pi = \frac{22}{7}$$

- Perimeter of the shaded region.
- Area of the shaded region.

12.

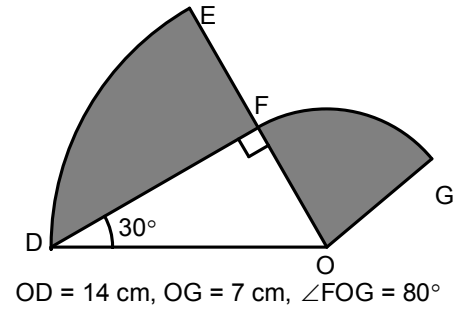

$$\pi = \frac{22}{7}$$

- Perimeter of the whole diagram.
- Area of the shaded region.

13.

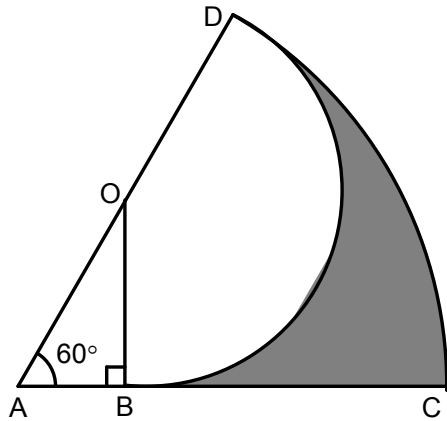

$OA = OD = 5 \text{ cm}, AB = 2.5 \text{ cm}$

$$\pi = \frac{22}{7}$$

- Area of the shaded region.
- Perimeter of the shaded region.

14.

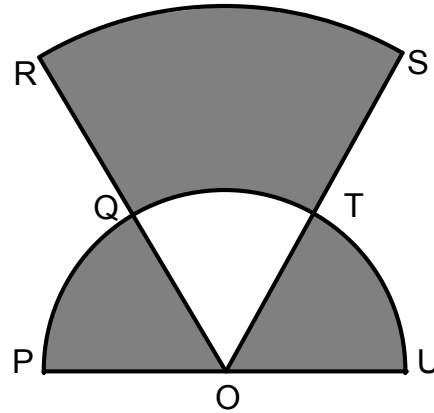

$OR = 2OQ, OQ = 3.5 \text{ cm},$
 $\angle POQ = \angle QOT = 60^\circ$

$$\pi = \frac{22}{7}$$

- Perimeter of the whole diagram.
- Area of the shaded region.

15.

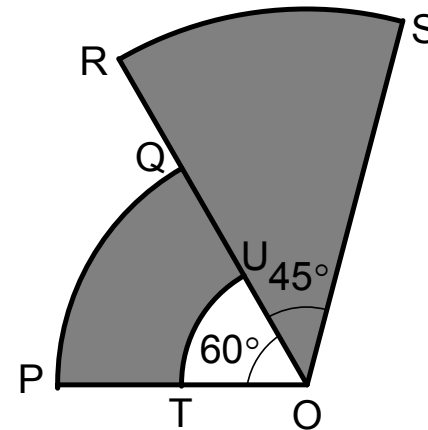

$OP = 2OT,$
 $OT = OU = QR = 7 \text{ cm}$

$$\pi = \frac{22}{7}$$

- Perimeter of the whole diagram.
- Area of the shaded region.

16.

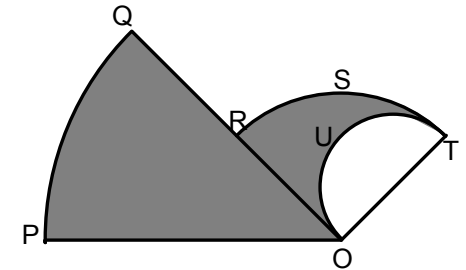

$OQ = 2OR, OR = 14 \text{ cm},$
 $\angle POQ = 45^\circ, \angle TOR = 90^\circ$

$$\pi = \frac{22}{7}$$

- Area of the shaded region.
- Perimeter of the shaded region.