

		REVISIONS			
ZONE	REV.	DESCRIPTION	DATE	APPROVED	

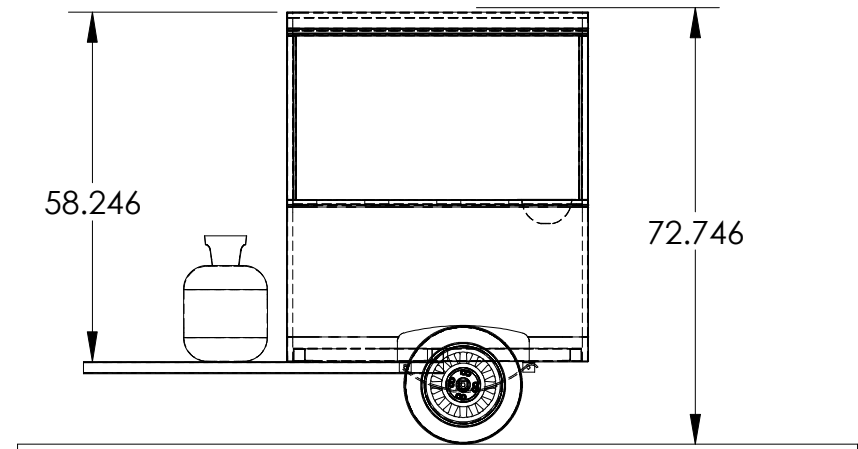
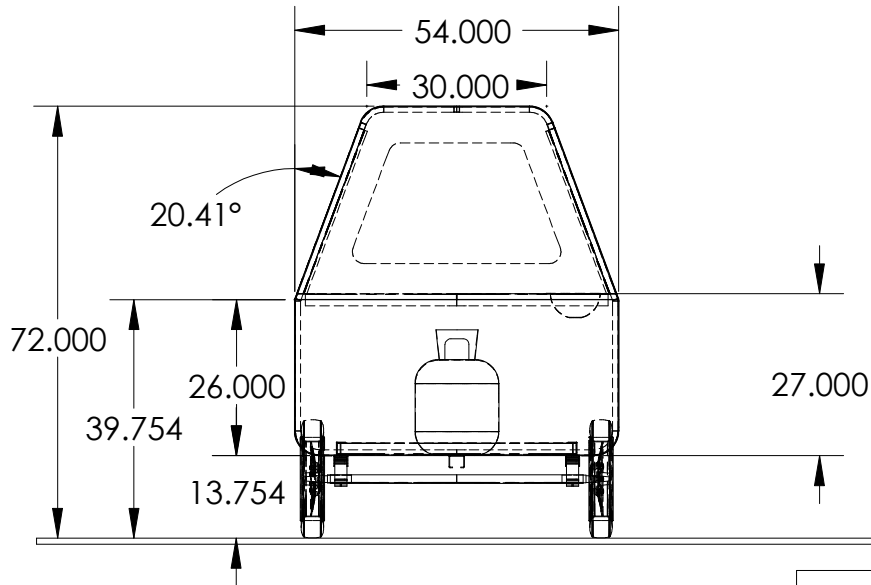
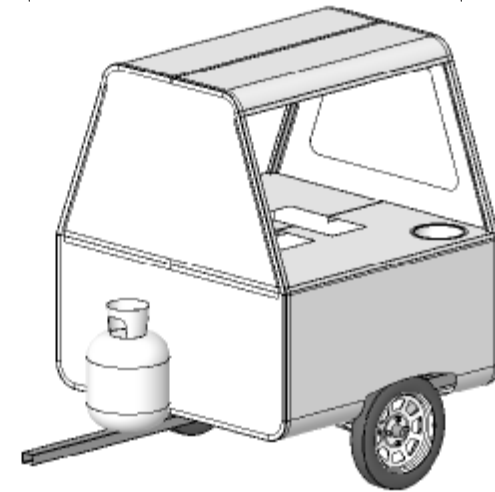
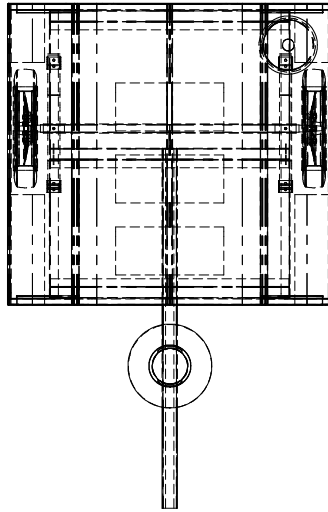

PROPRIETARY AND CONFIDENTIAL
 THE INFORMATION CONTAINED IN THIS DRAWING IS THE SOLE PROPERTY OF WOLFF ENGINEERING. ANY REPRODUCTION IN PART OR AS A WHOLE WITHOUT THE WRITTEN PERMISSION OF WOLFF ENGINEERING, IS PROHIBITED.

		DIMENSIONS ARE IN INCHES TOLERANCES: FRACTIONAL: ± 1/32" ANGULAR: BEND ± 1/2 deg. TWO PLACE DECIMAL ± .020" THREE PLACE DECIMAL ± .010"	NAME	DATE	<h2>Wolff Engineering</h2>
DESIGNER	LAWolff				
CHECKED					
ENG APPR.					
MFG APPR.					
Q.A.					
COMMENTS:					
NEXT ASSY	USED ON				
APPLICATION					
		SURFACE AREA = 81549.122 sq. in.			
		SIZE A DWG. NO. Dog Cart #2 Assy	REV.		
		WEIGHT = 13711.743 lbs.	SCALE=1:32 SHEET 1 OF 1		