

SERVICE BULLETIN ML 0016

Date : Tuesday, 18 April, 2000
Game : Time Buster (UK)
Subject : Fitting 12volt CE Transformer



Distribution List

- LAI Asia for Machines supplied to UK

The following instructions are for the fitting of the 12V CE approved transformer module to the 51 Time Busters shipped to the UK

INSTRUCTIONS

1. Remove all wires from Switching Power Supply, Fuse and Screw blocks. Then unbolt metal bracket and remove it from the machine (take note of what wire when where on the power Supply) Remove the four Fuse Blocks and the Screw Block, as they will not be used. (You can also temporarily remove the Switching Power Supply to make working on the bracket easier)
2. Using the attached drawing as a guide, drill four 6mm holes. Remove the Cover off the transformer module and bolt it securely to the metal bracket with four M5 x 10mm Nuts & Bolts (not supplied).
3. To prepare the wiring in the machine. One at a time cut the open ring terminals from the pairs of white and orange wires. Strip 10mm of insulation of the end of each conductor and solder the pair together. Cut a 600mm length of 3 core sheathed mains wire (not supplied) and strip 40mm of the sheath of each end. On one end, crimp the male Molex connector pins (supplied along with a 6-way housing). On the other end strip 10mm of insulation of the end of each conductor and tin with solder. See page 33 of the manual for the correct pinning of the 6-way Molex housing for your mains voltage.
4. Reassemble the metal bracket inside the machine and reconnect the wires to the Switching Power Supply. Feed the previously prepared sheathed mains wire through one of the vent holes near the Input screw block inside the transformer module and screw the tined conductor ends into the correct screw point. Active / Hot to Fuse screw point, Neutral to return screw point and Earth to the remaining screw point.
5. Feed the White & Orange pairs of wirers wire through one of the vent holes near the Transformer output screw points. Connect one pair of white wires to each of the four screw points marked "Common Output". Connect one pair of orange wires to each of the four screw points marked "Fused Output". Connect 6-way Molex mains input connector then double check all wiring and close cover on transformer module.
6. Check all harness connectors and restore any loose or interrupted connections and power up machine.

Regards

LAI Games

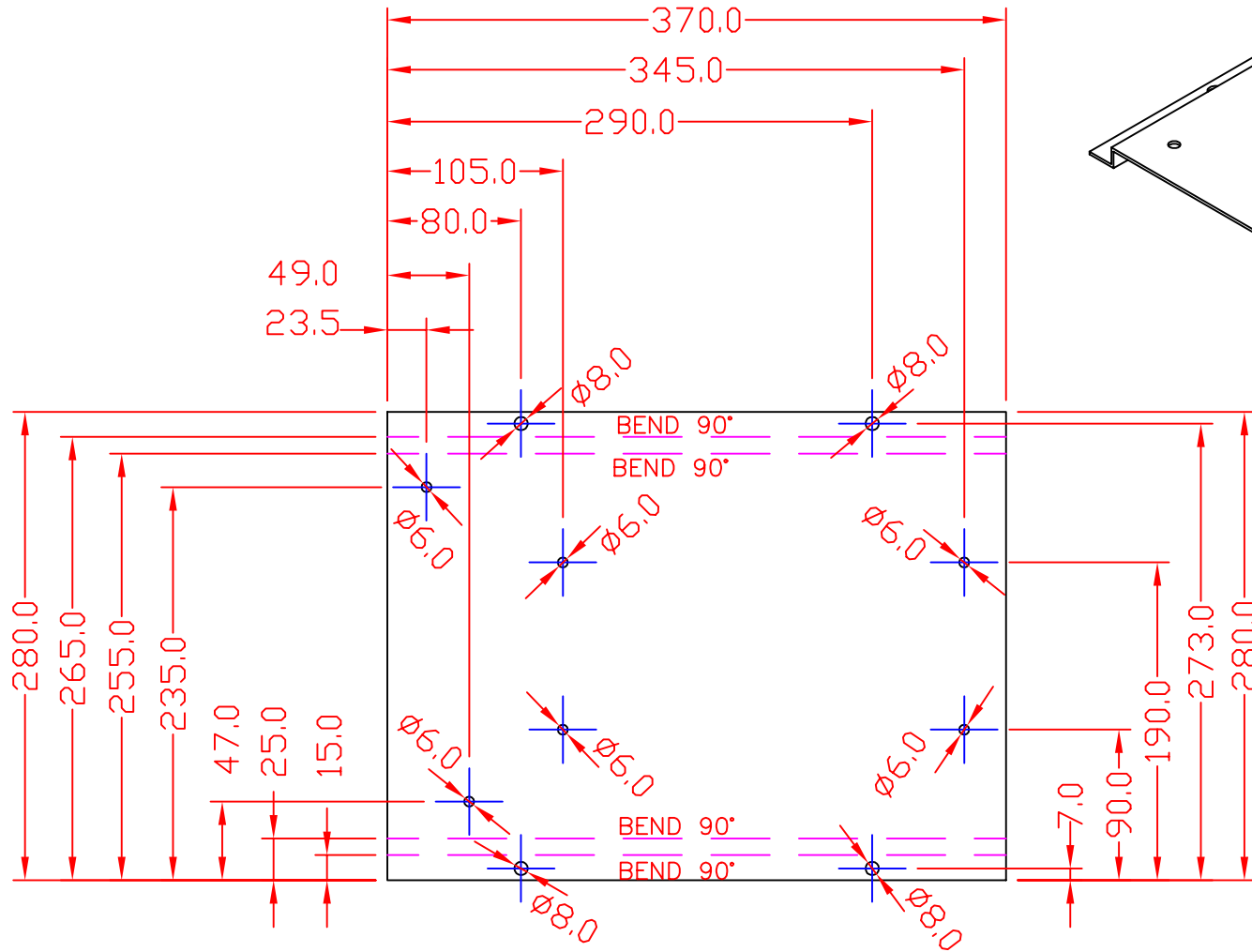
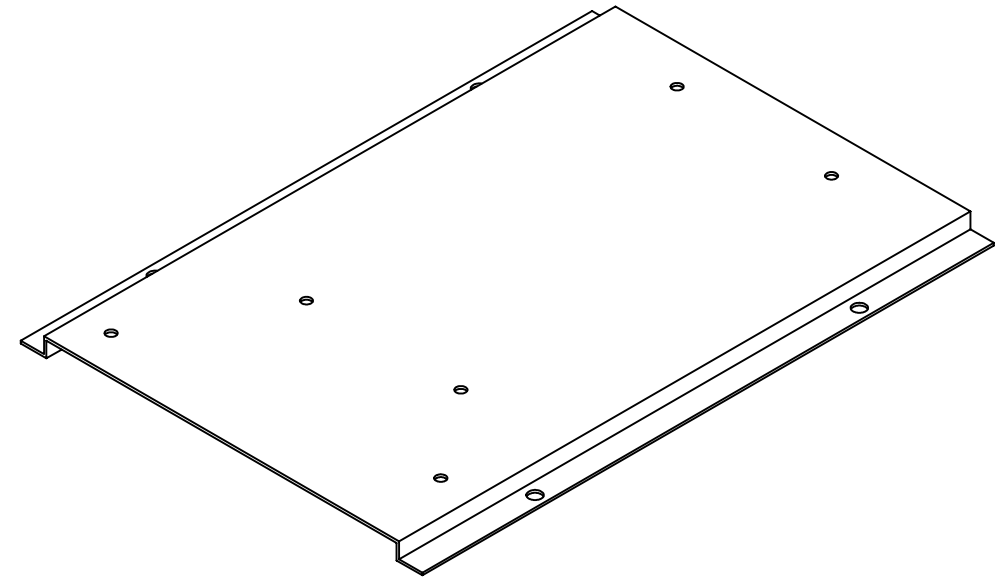

LAI Games

PROJECT TIME BUSTER

TITLE MAIN TRANSFORMER PLATE – UK

FILE NAME TRNSPLATE

DRAWN BY W.A.HAY DATE 31/03/00

DATE	ALTERATION

This drawing & design is the property of LAI Games and cannot be reproduced or copied, wholly or in part without prior written permission of LAI Games DO NOT SCALE

MATERIAL	MS BLACK FORM
THICKNESS	1.6mm
FINISH	BLACK
QTY PER MACHINE	1 OFF