

# SERVICE BULLETIN ML 0010



Date : 31 August 1999  
Game : Happy Hobos  
Subject : Excessive Guiding Ring Wear

## Distribution List

Australasia : - LAI WA, SA, VIC, NSW & QLD - Sales, Operations, Service Departments  
- LAI Games, NZ Coin Cascade, info@lai.com.au  
Asia : - ML Prod, ML Sales, MGF Operations, MGF Service, Philippines  
- LAI Asia Sales, Operations & Service

## Problem

: Prolonged Activation of the Cheat Detection Mechanism is resulting in excessive wearing to the Guiding Ring and Main Shaft Assembly. This is resulting in the Cheat Switch not activating and also in the collapse of the Movement Mechanism

## Solution

: A new Guiding Ring of Nylon to replace the original Iron Guiding Ring are now available at your closest LAI Games Distributor.

## Installation

Check the Serial Number Plate of your machine. Machines with a LAI Plate must use the Nylon Guiding Ring with a diameter of 56mm and those with a ML plate will use the Nylon Guiding Ring with a diameter of 60mm

Mark the location of the notch in the old Guiding Ring on the Plastic Pipe. Remove the Head Stop bracket and slide the Head Assembly out of the machine. Remove the retaining screw and old Guiding Ring, you may have to heat the pipe to help loosen it.

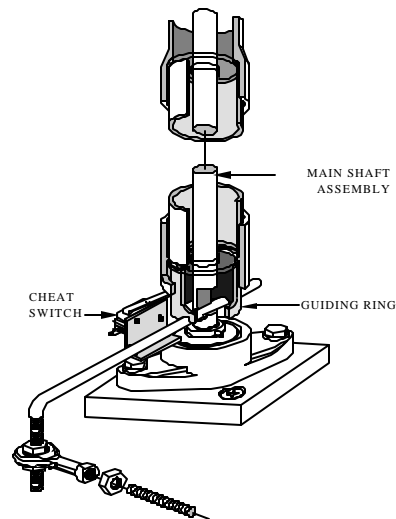

Insert the New Nylon Guiding Ring and align the notch with the mark you made on the plastic pipe. Drill a small pilot hole at the retaining screw hole and fit a self-tapping screw. It may be advisable to place a second retaining screw 90 degrees from the first.

Reassemble the head in the machine and check Cheat Detection mechanism for correct function. For details on adjusting Cheat Detection Mechanism, please refer to page 20 of your Service Manual.

Regards

**Matahari Leisure**