

Coupled Mode Theory Based Modeling of 2D Cylindrical Integrated Optical Microresonators

Kirankumar R. Hiremath, Manfred Hammer, Remco Stoffer

Department of Applied Mathematics, University of Twente, Enschede, The Netherlands

k.r.hiremath@math.utwente.nl

Optical microring resonators (MRs) are among the concepts at the focus of the current research on large scale integration of photonic devices. Conventionally, the ring resonator elements are described in the framework of a frequency domain model. A MR is functionally decomposed into two bend-straight waveguide couplers and the two bend waveguide (cavity) sections which internally connect the two couplers. Each coupler is externally connected to straight waveguides, which act as input/output ports. The advantage of this decomposition is that the modeling of a MR reduces to the modeling of the bent waveguides and the modeling of the bend-straight waveguide couplers.

The above formulation is crucially dependent on accurately and efficiently calculated bend modes. For this purpose, we developed a 2 D semi analytic planar bend mode solver. Having access to the analytic representation of the bend modes, we formulated and implemented a spatial coupled mode theory (CMT), which is based on variational principles (functional/reciprocity techniques), to model the bend-straight waveguide coupler. Solving the coupled mode equations numerically on a suitable computational window and taking the projection onto the (straight waveguide) port modes allows us to compute the scattering matrix of the coupler regions.

We obtain stable and surprisingly accurate results, even for quite compact and rather radiative cavities (see figure). The CMT results are compared with finite difference time domain results. It turns out that, for an accurate computation of the coupling constants, quite a large part of the radially extending basic bend mode profile has to be taken into account. The coupler scattering matrix obtained in this way forms the basis for the MR description. An extension of the model to unsymmetrical MRs or to resonators with multimode cavities should be straightforward.

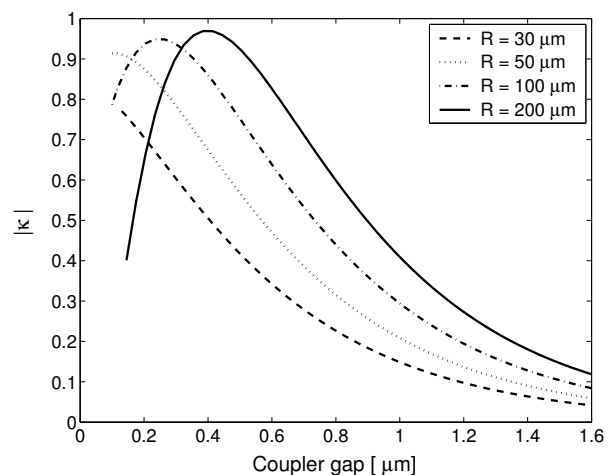
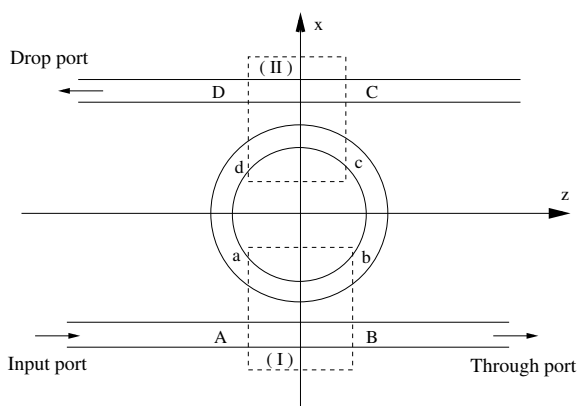

Left: Schematic decomposition of the MR into two coupler regions I and II, connected by the segments of the ring cavity. Right: CMT results for 2 D MRs. Variation of the absolute value of the straight waveguide to bend waveguide coupling coefficient (χ) for various disk radii (R) versus the coupler gap. Specifications: Bend waveguide and straight waveguides with core refractive index 1.6 and width $1 \mu m$, background refractive index 1.45, TE polarised light with a vacuum wavelength $1.55 \mu m$.