

Math 100 Lecture: Related Rates

Lecturer: Jose Maria L. Escaner IV, Ph.D.

Lecture 21

Related rates usually involve two or more variables changing with respect to time. For two variables, we assume that each x , y , or other variable-represented quantity are all functions of time t . Chain rule is usually employed as a technique in this case. For example, if x and y are related by $y = x^2$ where both both variables are functions of time, then their rates of changes (with respect to time) are related by the equation $\frac{dy}{dt} = 2x \frac{dx}{dt}$.

Examples:

1. If $x/y = 10$, and $D_t x = -5$, find $D_t y$.

It is important to understand here that both x and y are functions of t and that from the given, x and y are interdependent with each other. Now we can rewrite $x/y = 10$ as $x = 10y$ provided $y \neq 0$. Differentiating this equation with respect to t , we have, by chain rule, $\frac{dx}{dt} = 10 \frac{dy}{dt}$. Substituting the value $D_t x = -5$ we see that $D_t y = -1/2$.

2. A water tank in the form of an inverted cone is being emptied at the rate of $6 \text{ m}^3/\text{in}$. The altitude of the cone is 24 m and the base radius is 12 m . Find how fast the water level is lowering when the water is 10 m deep.

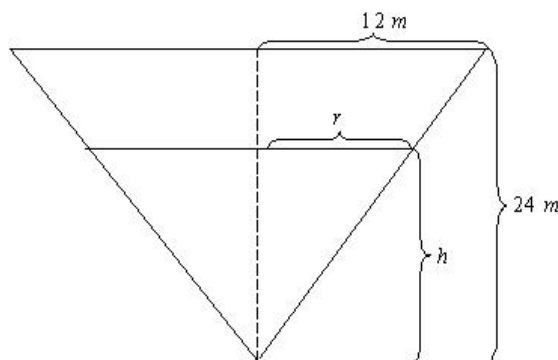

The volume of an inverted cone is $V = \frac{1}{3}\pi r^2 h$. Note that the volume formula is dependent on two variables namely, the radius r and the height h . What should be done for now is to reduce this equation so that the volume is only dependent on one of the variables. Looking at the figure, we see that ratio and proportion of similar triangles may be applied:

$$\frac{h}{24} = \frac{r}{12} \text{ or } r = \frac{h}{2}.$$

Substituting this equation in our volume formula we get $V = \frac{1}{3}\pi\left(\frac{h}{2}\right)^2 h = \frac{1}{12}\pi h^3$. Differentiating both sides with respect to t we get

$$\frac{dV}{dt} = \frac{1}{4}\pi h^2 \frac{dh}{dt}.$$

Given $h = 10$ and $\frac{dV}{dt} = -6\text{m}^3/\text{in}$ (the negative sign indicates that the volume is decreasing), then

$$\frac{dh}{dt} = \frac{4}{\pi h^2} \frac{dV}{dt} = \frac{4}{100\pi}(-6) = -\frac{6\pi}{25} \text{ m/s}.$$

Again the negative sign indicates that the height is decreasing.

Exercises:

1. A pebble is dropped into a clam pool of water, causing ripples in the form of coencetric circles, the radius r of the outer ripple is increasing at a constant rate of 1 foot per second. When the radius is 4 feet, at waht rate is the total area A of the disturbed water changing?
2. A ladder 25ft. long is leaning against a vertical wall. If the bottom of the ladder is being pulled horizontally away from the wall at 3 ft. per second, how fast is the top of the ladder sliding down the wall when the bottom is 15ft. from the wall?
3. Air is being pumped into a spherical balloon at a rate of 4.5 in^3 per min. Find the rate of change of the radius when the radius is 2 inches.
4. A company is increasing its production of a certain product at the rate of 200 units per week. The weekly demand function is given by $p = 100 - \frac{x}{100}$ where p is the price per unit and x is the number of units produced in a week. Find the rate of change in the revenue with respect to time (in weeks) when the weekly production is 2,000.
5. Sand is being emptied from a hopper at a rate of 10 ft^2 . The sand forms a conical pile whose height is always twice its radius. At what rate is the radius of the pile increasing when its height 5 ft ?
6. The width of a rectangle is half its length. At what rate is its area increasing of its width is 10 cm and is increasing at 0.5 cm/s ?
7. A circular oil slick of uniform thickness is caused by a spill of 1 m^3 of oil. The thickness of the oil slick is decreasing at a rate of 0.1 cm/hr . At what rate is the radius of the slick increasing when the radius is 8 m .
8. A company is increasing its production of a certain product at the rate of 25 units per week. The weekly demand and cost functions are given, respectively by $p = 50 - \frac{x}{100}$ and $c = 4000 + 40x - 0.02x^2$, where p and c are prices per unit and x is the number of units produced in a week. Find the rate of chante of the profit with respect to time when weekly sales are $x = 800$ units.