

17 February 2013

Dr Eng. Jan Pająk
"Web pages of Jan Pająk - [artefact.pdf](#)"
(i.e. a brochure with text of the web page named [artefact.htm](#)
entitled "Sensational artefacts left from ancient telepathic devices")
Wellington, New Zealand, 2013,
ISBN 978-1-877458-69-9.

Copyright © 2013 by Dr Jan Pająk.

All rights reserved. No part of this brochure may be reproduced, stored in a database or retrieval system, transmitted, or distributed in any form or by any means, electronic, mechanical, photocopying, recording, or otherwise, without the prior written permission from the author or a person legally authorized to act on his behalf. From the obligation of getting such a written permission are only released those who would like to prepare a single copy of this monograph for their personal use oriented towards the increase of their knowledge and who fulfil the condition that they will not use the copy prepared for any professional purpose or for accomplishing material gains, and also that they copy the entire brochure - including the title page, all items, all illustrations, and all enclosures.

Date of the latest update of the web page presented in this brochure is provided above in the top-left corner. (Note that in case of having access to several copies of this brochure, it is recommended to read the copy which has the latest date of amendment.)

This brochure publishes the text of the web page authored by Dr Eng. Jan Pająk, indicated in the title of it. In turn the author's web pages are forms of fast reporting to the readers results of scientific research accomplished by the author of this brochure. The author is aware, that this research, and the results, are unique, as no-one in the entire world undertook earlier research of topics elaborated in this brochure. Therefore ideas which this brochure presents are the intellectual property of the author of this brochure. All ideas, theories, inventions, discoveries, explanations, descriptions, etc., published here, which have documentary or evidential value, are presented accordingly to standards applicable for scientific publications (reports). A special attention the author has given to the requirement of repetitiveness, i.e. that on the basis of this brochure any professional scientist or hobby investigator who would like to verify, repeat, or extend the author's research should be able to recreate his work and arrive at the same or very similar results and conclusions.

This brochure is another one from a series of similar brochures in PDF, offered free of charge to interested readers by the totaliztic web page named [text 11.htm](#) - which disseminates PDF versions of most significant and most widely read web pages by the author. The topic of this brochure is represented also in the newest [monograph \[1/5\]](#) with following editorial details:

Pająk J.: "Advanced Magnetic Devices",
Monograph, Wellington, New Zealand, 2007, 5th edition,
in 18 volumes, ISBN 978-1-877458-01-9.

Contact addresses to the author valid in 2013 - i.e. during the preparation of this brochure:

[Dr Eng. Jan Pająk](#)
P.O. Box 33250, Petone 5046, NEW ZEALAND
Email: janpajak@gmail.com

If the reader of these words is NOT a professional scientist, then he or she probably has already heard the name "telepathy". This is because only professional scientists still do NOT know what this name means. After all, the exploration of it is prohibited by inner doctrines, customs, traditions, procedures and culture of the present official science - which (science) qualifies the "telepathy" to the category of "scientific heresy". The reason is that this monopolistic institution of official science already shifted onto practicing the stand, which states that "if the truth and facts are against what the science says, then it is worse for that truth and facts", - fortunately, this currently-practiced doctrine of the present is NOT imposed yet onto the whole society. Thus, some people still can devote themselves to the study of truths and facts. While knowing what "telepathy" means, the reader may be interested in the fact, that in ancient times, people had and used various highly advanced telepathic devices, which contained in themselves the level of knowledge that exceeded the present level of science and technology by at least 100 years.

On this web page I am going to describe three such ancient telepathic devices, whose working prototypes already existed and have been used in ancient times. The first amongst devices described here, is the telepathic detector of impending earthquakes, in present times wrongly called the "[Zhang Heng Seismograph](#)" - because it was built nearly 2000 years ago by a Chinese genius named Zhang Heng. (In fact, this telepathic device of Zhang Heng I was forced to "invent" again from the very beginning, when I was working out how it really operated in antiquity. This is because all descriptions of its supposedly "inertial" operation, which existed before this my repeated "inventing" of it, were completely wrong.) The second device described here is the "telepathic telephone". The model of it, composed together from elements produced in the Middle Ages, can be viewed today in the Marian church from Gdansk, Poland. The design and operation of this "telepathic telephone" I also needed to "invent" from very beginning. Just as today's "mobile phones" allow to carry voice calls via electromagnetic waves, but they induce cancers and debilitate bees with their

destructive radiation, also this my "telepathic telephone" allows to carry out voice calls while using extremely safe telepathic waves. The third amongst telepathic devices described here is the "[telepathic pyramid](#)". Although the model of this pyramid was "given" to the humanity, the true operation of it again I was forced to "invent" from the very beginning. This pyramid allows for a purely telepathic exchange of thoughts between the people that use it, with a complete elimination of speech. In a distant past, an ancient device working just as this "telepathic pyramid" - but on interstellar distances, turns out to be the stone structure called the "Pyramid of Cheops" from Giza, Egypt. All three ancient telepathic devices described on this web page have this to themselves, that their design and operation are shockingly simple, and thus that virtually any reader can find for himself or herself some way in which could contribute actively to their rebuilding today - so that they began to serve again for the good of people and raise our civilization onto a higher level of awareness.

Part #A: Introductory information of this web page:

#A1. What are goals of this web page:

The real goal of this web page is **to reveal to the reader that already in ancient times existed on the Earth working prototypes of very useful telepathic devices**, which technical production is so simple, that they can be constructed with materials and tools which people possessed several thousand years ago, but the knowledge contained in which is still significantly higher than the present level of science and technology on the Earth. In other words, this web page is designed to expose to the reader, that there are already known very useful telepathic devices used in ancient times, the rebuilding of which lies in possibilities of a significant proportion of today's hobbyists, but from the useful operation of which the present human civilisation is NOT benefiting because **the present official science refuses to learn about them and to research them**. For the rebuilding of these devices, a large proportion of present individual hobbyists already have almost everything, means the required conditions, materials, tools, finances, etc. Only that to actually rebuild these devices, such hobbyists need to also obtain from someone the knowledge about the operation of these wonder devices, and also they must themselves demonstrate the possession of required for this "devotion", "open mind", "creative approach", and the "inventive sense".

An additional goal of this website is to realise to the reader, that because of the open ignoring of these devices by the present official science (which science considers them to be the "objects of scientific heresy" - because their principle of operation is based on the "[telepathy](#)" which is officially denied by this science), yet another way to extract them from oblivion and to reintroduce into the service for humanity, is a "**popular uprising**" for research and development. In this kind of "popular uprising", anyone who has the necessary ability and willingness, would contribute to the building of these devices, through completing any activities that would be linked to them - for example through: publishing about them and directing the attention of other people at their existence, the historical or field exploration and analysis of examples of their existence (e.g. in old churches), visiting and seeing their models and exhibits that are already located in places where they are detected (e.g. in the church of the Virgin Mary in Gdańsk, Poland), organizing experiments on already existing and found examples of them, analyzing or speculating about the work of such old devices (such as the so-called. "confessions" from old church) which can represent their examples, reading and writing about them on the Internet, analyzing where, how and with what funds they could be rebuild, etc., etc.

#A2. The humanity has already a precedence of "popular uprising" for research and development - it is the present development of new energy devices and principles of energy generation:

To these readers, who have doubts as to whether a "popular uprising" for building telepathic devices will give any visible results, I suggest to consider the results already obtained by other "**spontaneous popular uprising**", that has occurred on Earth in the exploration, research, and development of new energy devices and new principles for the generation of energy. As readers probably already noticed, in matters of energy science and scientists already do NOT count completely. The only thing that scientists still do, is to teach about energy on campuses, but all the research, development, and applications have been taken over by individuals and institutions outside of universities and outside of the circle of professional scientists. And so, today's industry, researches and develops new devices for the generation and use of energy. Ordinary people support these efforts by selecting the industry's most energy efficient solutions, by buying, and by installing them in their homes, these new devices, etc., etc. In turn the individual hobbyists and inventors are working on new methods for energy generation in areas ignored by the official science, such as "**free energy devices**", "**zero emission cars**", etc.

#A3. Why the knowledge which allows for reconstruction of ancient telepathic devices described on this web page, requires a "popular uprising" rather than the official science financed from our taxes:

The "pursue of knowledge" by the official science already "hit a brick wall". This proverbial "wall" for the science turns out to be acceptance of already accumulated **evidence for the existence of God**, or more strictly the change of philosophical approach to research, from the previously used by the official science approach called "a posteriori" - means "from effect to cause" into a new scientific approach called "a priori" - meaning "from cause to effects" or "from

God understood as a superior **cause** of everything to the surrounding reality understood as **effects** of the actions of God". Without the undergoing such a change in approach to research, the official science is NOT going to pursue virtually any true new knowledge, and it will behave like a cow, i.e. it will only "re-chew" of old knowledge - what I try to emphasize in item #G4 from the web page named [eco_cars.htm](#). So if the humanity wants that the science begin again the "pursue of knowledge", then people must somehow force scientists into it. So far, they are on the Earth two tried ways of "forcing" this still monopolistic institution of official science to abandon its present attitude characterised by the popular saying "**if the truth is against of what we say, then the worse for this truth**" and the science started to actually "pursue a new knowledge". One of these ways is the "popular uprising" described in the previous item of this web page. It was "spontaneously" created by itself, amongst others in the energy area, because the official science refused in there "to pursue new knowledge" regarding energy - while simultaneously for such a new knowledge opened a social need. A similar "popular uprising" recently started to appear soon after the publication in Internet my formal proofs for the existence of God - described in items #G2 to #G4 from the web page named [god_proof.htm](#). At present it takes a form of a new, more scientific than previously, version of a relatively old movement, which for sometime is called "creationism". In turn another way, which so-far is postulated only by myself, because I believe that it will be even more effective and more permanent than a "popular uprising" is to takeaway from the preset institution of official science its "monopoly for knowledge" by the official establishing of yet another, new institution of science, that will be competitive with the old science, because it is to base its research on this new philosophical approach called "a priori". The scientific and philosophical foundations of just such a new "totaliztic science" have already been developed and are described in items #C1 to #C6 from the web page named [telekinetics.htm](#). So the only thing that still remains to do in this matter, is to officially establish it and assign to it appropriate financing that is required for undertaking the effective "pursue of knowledge".

Part #B: Description of the artefact of "Zhang Heng Seismograph":

#B1. What is that "[Zhang Heng Seismograph](#)"?

The Zhang Heng Seismograph is an extraordinary device. It works by intercepting subtle telepathic emissions yield by impending earthquakes. Ancient Chinese used to call these emissions with the name **chi**, while currently they are

described as "telepathic waves". The Zhang Heng Seismograph was build almost 2000 years ago, but it still exceeds the present level of science and technology on Earth by at least further 100 years - for estimates of this exceeding see item #F6 from the web page named [seismograph.htm](#). If the working prototype of it is build, it will open completely new horizons for people and for the humanity. After all, it NOT only allows for remote detection of impending earthquakes and for issuing advanced earthquake warnings. It also assists in learning about telepathy, which so-far remains unacknowledged by the official human science - i.e. this science which is described in items #C1 to #C6 from the web page named [telekinetics.htm](#).

* * *



Fig. #B1: The general appearance of a present-day replica of the "Zhang Heng seismograph" (means of a replica of the ancient device able to detect the impending earthquakes and to rise alarms a sufficient time **before** these earthquakes strike, to allow for a safe escape from the danger zone).

The replica of this earthquake detector shown above as "Fig. #B1", is that one which until 2011 (i.e. until the [earthquake in Christchurch](#)) was exhibited in New Zealand in the [Te Papa](#) museum of Wellington. This is also the replica that I studied to work out how it operates. (A description of the unique operation of this device, as well as equally unique its fate, is provided in items #D1 to #I1 from the web page named [seismograph.htm](#) that can be downloaded free of charge from "[Menu 1](#)".) Descriptions provided on this web page eventuated because, by a strange turn of fate, the above device happened to appear just a few kilometres from my flat, while I was seeking it in the entire big world, being prepared to even fly to China just to see it.

* * *

Notice that you can see the **enlargement** of each illustration from this web

site. For this, it suffices to **click** on this illustration. Furthermore, most of the internet browsers that you may use, including the popular "Internet Explorer", allow also to **download** each illustration to your own computer, where it can be looked at, reduced or enlarged to the size that you may want, or printed with your own graphical software.

If one wishes to **shift** a given Figure (i.e. a photograph or a drawing) - means if one wishes to **move this Figure into another part of the screen where e.g. a description of it is located**, and when simultaneously one wishes to reduce or reconfigure the separate window in which this illustration is to appear, then one needs to do as follows: (1) click on this illustration to make it appear in another new window, (2) make sure that this new window is set for capability to be reconfigured and shifting along the screen (for this one needs to have a look at the middle square out of the three squares present in the top-right corner of the screen - this middle square should contain inside just a single screen-icon, so if there are two such screen-icons inside of it, then one needs to click on them to turn them into a single screen-icon), (3) the "downsize" or "reconfigure" this another new window (with a given illustration) through "grabbing" its right-bottom corner with the mouse and then dragging this corner upwards-left to receive the required size and configuration of this different new window (notice that since this new window is downsized or reconfigured, then it is to stay this way for all next Figures being clicked - unless one enlarges or reconfigures the window again), and then (4) drag this another new window with the Figure that one wishes to relocate, to the area of the web page where one wishes to look at it e.g. because there is a description related to it (to move the new window with a Figure, one needs to just grab it with the mouse by the blue stripe on the top of it and then drag it to the required place). Notice also that if one scrolls (with scroll-bars) the text of a page when one reads it, this another window (with the illustration) is going to disappear. In order to return it into the new position on the screen, one needs to click on its "icon" (i.e. on the "program's button" from the taskbar) in the lowest part of the screen.

#B2. How the "Zhang Heng seismograph" really looks like?

To determine the actual appearance of original prototype of the "Zhang Heng Seismograph", one needs to know its principles of operation. Unfortunately, historians who have tried to establish this appearance just on the basis of various historic sources and premises, do NOT know these principles of operation. After all, these principles for the first time in the world was developed only by the author of this web page. Therefore, to the products of activities of these historians crept several vital misinterpretations.

Almost the actual appearance of the "Zhang Heng Seismograph" is shown on a number of illustrations from the separate web page named [seismograph.htm](#) - for example see in there photographs or drawings marked Fig. #E1a, #E1b, #E1c and #F2. However, to NOT trouble the reader by

sending him over there, here's a repetition of one amongst those illustrations, i.e. "Fig. #E1b":



Fot. #B2: Here is a drawing that best reflects almost the true appearance of the "Zhang Heng Seismograph" – apart for the fact that it still shows a wrong slope of mouths of dragons, and a wrong shape of the top surface (cover). This surface, or rather a cover the device, in fact, was almost a perfect hemisphere (similar to the cover of the device from "Fig. #B1), and is NOT like that shown above rim or "sew" of a pot.

Originally the above illustration is presented at the web page named [seismograph.htm](#) - where it appears as "Fig. #E1b".

#B3. How works the "Zhang Heng seismograph"?

Descriptions of the construction and operation of the "Zhang Heng Seismograph" are presented in items #F2 and #F3 from a different web page named [seismograph.htm](#), in the conference paper by the author of this web page, entitled "[Signal processing in the 'Zhang Heng Seismograph' for remote sensing of impending earthquakes](#)" (the editorial data for this paper are published in item #I1 from the abovementioned web page named [seismograph.htm](#)), and also in subsection K6.1 from volume 9 of the [monograph \[1/5\] of the author](#), entitled "Advanced magnetic devices" (available free of charge in the Internet, amongst others, through the green links from this web page).

#B4. Is there any artefact of the "Zhang Heng Seismograph" known to the author of this web page and how this artefact could have helped us to reproduce a working prototype of the device?

Not long ago, because in 2005, a sensational artefact has surfaced. It is shown in photograph from "Figure #B3" below. It presents an apparent ancient replica of the so-called "Zhang Heng Seismograph". The puzzling question which we all should try to answer is: from what period it originates, and whether it is a genuine artefact or just a present fake? We sincerely hope that the reader helps us to find the correct answer to this question.

* * *



Fig. #B3: The general appearance of sensational ancient replica of the "Zhang Heng Seismograph".

The height of this replica is about 40 cm. So it can't be the working device, but a model of a seismograph that existed and worked in ancient times. Also there is no mechanism inside the egg-shell, what can be seen when one removes the top cover and looks inside of it. This seems to confirm additionally that it is only a model of a real thing. The pattern on this replica seems to indicate that it

may originate from the Western Zhou period (1100 BC to 770 BC). This in turn could mean, that the "Zhang Heng seismograph" could even be over 1000 years older than it is currently believed. More details on this ancient replica of the "Zhang Heng seismograph" may provide Mr Tan Kee Wee, who can be contacted via the email address keeweetan@pacific.net.sg.

#B5. What induces our interest in the artefact described here:

On several web pages I try to indicate that the free development of science and technology on the Earth is strongly suppressed by an invisible "evil force", which is interested that the humanity remains in darkness. "Menu 2" provides numerous examples of web pages which document the action of this "evil force". For example, web pages about [Aleksander Mozajski](#) (e.g. see the page named [mozajski_uk.htm](#)) illustrate how this "evil force" suppressed the development of the first aeroplane on Earth. In turn web pages about mysteries of [New Zealand](#) (e.g. see the web page named [newzealand.htm](#)) explains how this "evil force" escalates the so-called "curse of inventors" that suppresses all progressive inventions on the Earth. It seems to be in the vital interests of this "evil force", to also suppress the current trend to rebuild an operational duplicate of the "Zhang Heng Seismograph". In order to accomplish this evil goal, this "evil force" could resort to even such actions as to create a fake replica of this seismograph to misled those researchers who wish to rebuild it. Thus, the extremely vital questions which we all should try to answer now, is whether the ancient artefact shown in "Fig. #B3" is a genuine item or just a skilfull fake, and if it is genuine - then from what exactly period it really originates. I hope that readers of this web page are going to help both of us (means [myself - Dr Jan Pajak](#) and Mr [Tan Kee Wee](#)) in finding answers to these difficult questions.

#B6. Why it is vital to establish how genuine the artefact from "Fig. #B3" is:

There are numerous reasons why it is vital to establish beyond any doubt that the artefact discussed here is genuine. Let us have a look at some of these reasons:

1. It would show how the working prototype of the "Zhang Heng Seismograph" really looked like. After all, the replicas of the "Zhang Heng Seismograph" that we have and show at present (e.g. the replica shown on "Fig. #B1"), are reconstructed from our guess and imagination rather than from our true knowledge as to how the real device used to look like.

2. It would facilitate our deductions of vital information about the true operation of the "Zhang Heng Seismograph". In turn such deductions, if they

are fairly accurate, would allow to complete a working model of this "seismograph" much earlier. (Notice that I am not very happy to call the Zhang Heng device with the name "seismograph", because this name implies the inertial operation of it. On the other hand, as explains this the web page named [seismograph.htm](#), this apparatus operates on "chi" (i.e. on "telepathy"), not on "forces of inertia".

3. It would allow to establish who is the true creator of the "Zhang Heng seismograph". The point is, that judging from the patina and the extensive demineralisation in the pieces of the device discussed on this web page, it appears that this device could be older than the Han Dynasty period. This in turn has the consequence, that this artefact bears the potential to suggest or to prove, that Zhang Heng was not the original inventor of this device, but just only restored it from some older model that he examined. Putting this in other words, if the pictured bronze is as old as the Western Zhou period, this would mean that the seismograph was not invented by Zhang Heng after all. He could have taken the idea from an invention made far earlier. So the device shown here, if proven genuine, is going to change the statements of history.

4. The shape of it implies, that the device is modelled like a propulsor from a UFO vehicle - for more details see item #C2 below. This in turn would explain why the "Zhang Heng seismograph" is so advanced, that it even exceeds the level of present science and technology on Earth. After all, the advancement of it would then originate from a "simulated" cosmic civilisation, which supposedly donated this device to people from the planet Earth - as it is explained in item #L2 from the web page named [magnocraft.htm](#).

To summarise the above, it is worth to undertake the effort to prove or to disprove that this artefact is genuine, and to date it more exactly.

* * *

(**Note** that you can see the **enlargement** of each illustration or photograph from this web site, simply by **clicking** on this illustration or photograph. When you finish with looking at such enlargement, click **BACK** to return to this page. You can also download each illustration to your own computer, and then look at it, reduce or enlarge the size of it, or print it, with your own graphical software.)



Fig. #B4: Another beautiful pieces of ancient Chinese bronzes. They are "fang hu" from the Spring-Autumn period (770 BC to 476 BC). ("Fang hu" were containers used to store wine. They were like present wine decanters.) They reveal a clear pattern on the side, which is unique for this particular period. Compare the designs on the body of it, with these from "Fig. #B5" below. The strange thing is that also the ancient replica of the "Zhang Heng seismograph" discussed here, displays almost identical design patterns on the egg-shell chamber - see also "Fig. #B5" below.

Please notice that there are not many Chinese bronze experts in this world. Most of them live in China. That's because there are so few pieces of Chinese ancient bronzes left in this world. So to recognise and to decode patterns that exist on the device discussed here, takes quite a lot of expertise which apart from China is not readily available.

#B7. What premises seem to certify that it is a genuine artefact from the Western Zhou period (1100 BC to 770 BC):

There is several premises, which stem from the current knowledge of ancient Chinese bronzes accumulated by historians, antiques collectors, and other experts with artistic inclinations, and which seem to certify that the artefact discussed here originates from the Western Zhou period (1100 BC to 770 BC). Let us list here these premises:

1. The demineralisation stage of the object discussed here, and the caked dirt on it. As pictures shown on this web page reveal, the state of the object discussed here is such, that it convincingly indicates that the age of it is extremely old. The bronze is strongly oxidised and demineralised, it is covered with very old dirt deeply caked into the surface of it, and it is damaged solely by its age. All this makes experts from that area fairly certain, that the object came from a period much earlier than the Han Dynasty.

2. The pattern of the design. A guess based on the patterns displayed by the bronze object, indicates that it may originate from the Western Zhou period (1100 BC to 770 BC). But of course, it could have been made much later.

3. The simplicity of the design. Most of Han Dynasty bronzes usually have very simple designs. That is why the design seems to indicate that this replica of the seismograph could be even earlier than from the so-called "Spring-Autumn Period".

* * *

Of course, apart from premises that seem to certify for historic origin of this artefact, there are also premises which seem to indicate that cannot be ruled out completely a possibility that it is only a skilfully made fake. They stem from the knowledge accumulated during my (i.e. Dr Jan Pająk) research on the [Zhang Heng Seismograph](#). Here are some of these premises:

A. The presence of whole dragons, not just dragon heads. Historic descriptions of the "Zhang Heng Seismograph" indicate, that to the egg-shell body only dragon heads were attached, not whole dragons as it is visible on "Fig. #B3" and "Fig. #B7". (The true shape of these dragon heads is shown in Figures #E1a, #E1b, #E1c, and #F2 from the web page named [seismograph.htm](#)) The presence of whole dragons could suggest that the artefact was made recently by someone who does not know ancient descriptions, thus does not know that there were no whole dragons attached to this device.

B. The downwards angle of positioning dragons' mouths. As this is visible on "Fig. #B3" and "Fig. #B7", dragon mouths are directed downwards. In turn such their directing makes impossible the proper operation of this device, no matter what principle of operation it would use.

C. The colour. If bronze oxidises naturally when it is being used, the colour of the layer of oxidation is usually black, not greenish. So the greenish colour of the oxidation on the artefact may rouse suspicions. Unfortunately, the significance of the colour is inconclusive, because it depends on the copper content of the material, and also on conditions of oxidation. For example, the bronze oxidised very rapidly (e.g. in a fire, or in the presence of chemicals or sea water) also would oxidise into such a greenish colour.

Of course, the above points could also be caused by a simple environmental conditions, lack of thoroughness, or artistic vision of the creator who made this replica. So they not necessarily are conclusive.



Fig. #B5: This picture reveals the pattern on the egg-shell of main chamber from the "Zhang Heng Seismograph" discussed here. Although this photo is not taken from the correct angle (it was planned to be replaced in the future with a better photo), it shows this pattern quite clearly. In turn the presence of such a pattern may indicate that the replica discussed here in fact does originate from the Western Zhou period (1100 BC to 770 BC).

#B8. In what manner readers could help in this research:

There are numerous ways in which the reader could help in establishing whether the artefact discussed here is genuine. Let us list the most vital of these ways:

1. Inspiration. Readers could have and let us know any other ideas as to how prove or disprove that this artefact is genuine.

2. Intuition. Readers could share with us their intuitive feeling about how genuine this artefact is. In turn this feeling they obtain after reviewing carefully photographs presented on this web page.

3. Research. These readers who have access to research facilities could do laboratory research on samples that we are willing to provide. For example, the radioactive isotope dating of this object could be carried out by them.



Fig. #B6: Myself - i.e. Dr Jan Pajak and Mr Tan Kee Wee we would greatly appreciate the reader's opinion regarding the evidential value of the artefact presented here.

We would be grateful if, after careful reviewing photographs shown on this web page, and careful reading information provided on this web page and on the [seismograph.htm](#) readers could share with us their personal opinion as to whether their intuition tells them that this replica is a truly ancient artefact originating from the Western Zhou period (1100 BC to 770 BC), or just a skilfully made fake. We would also be grateful for readers' suggestions, as to what other research could be done to verify the true origin of this artefact.

#B9. Curious aspects of the object

discussed here:

The object discussed here displays several aspects that may raise our curiosity. In order to mention an example of one such aspect, it is the downward positioning of dragons' mouths shown in "Fig. #B7", and the relative size of the "pearl" kept in these mouths. Present replicas of the "Zhang Heng seismograph" position dragons' mouths differently, and also use a different size of the pearl. The reason is, that whatever principle of operation of this device one would consider, it still would NOT work if the mouths of the dragons are directed downwards. So what was the reason for which these mouths were positioned in such a manner? Perhaps the reader has a suggestion regarding this strange positioning.



Fig. #B7: Should the ancient replica of the Zhang Heng seismograph prove itself to really originate from the Western Zhou period (1100 BC to 770 BC), then it would become forus a source of valuable information and inspiration.

As an example, consider details of the dragons' mouths and pearls hold in there.

Part #C: Is it possible, that the "Zhang Heng Seismograph" originates from

intelligence other than that of humans?

#C1. How it is possible, that the principles of this device still exceed the present level of human knowledge by around 100 years?

It is explained on the web page named [seismograph.htm](#), that the human science needs at least 100 years of the further development, to fully understand telepathic phenomena and principles of operation involved in work of the "Zhang Heng Seismograph".



Fig. #C1 : The overhead view of the artefact discussed here. The special meaning has the eight-sided base of this replica. This is because the eight-sided objects present in human culture seem to mimic the propelling devices called the "[Oscillatory Chambers](#)" (shown in "Figure #C2" below), that are used in propulsion systems of such advanced vehicles as e.g. telekinetic UFOs.

#C2. Aparent cosmic origin of the Zhang Heng seismograph:

Strangely enough, the object discussed here displays several attributes, which seem to indicate that it could originate from a "gift to humanity" which is so "simulated" as if it is send to the Earth by "other civilisation". Most prominent amongst these attributes are their unique and meaningful shapes. Other such

attributes

include:

1. The huge, if not excessive, knowledge necessary to build this device and to make it work. This knowledge foreruns even the present level of official human science and technology by at least 100 years. It seems almost impossible that ancient Chinese gathered this knowledge already a few thousands years ago all by themselves.

2. The octagonal base. As this is documented in this item here, and in item #C3 that follows, the shaping of base of this device into an octagonal figure, is trying to tell us something. This is because the formation of an octagon is not an easy task. So if the shape of the base would be just for ornamental purposes, then it would be formed as a six-sided figure which is extremely easy to design and to make. But if ancient masters persevered in creation of the difficult octagonal shape, they must have a vital reason for it. This reason is the message about a cosmic origin of the device, that such octagonal base tries to deliver to us.

The point which I am trying to make here, and in item #C3 below, is that in old times the octagonal shape used to symbolise the supernatural source, magical powers, and the cosmic origin. In the Chinese culture the best symbol of such cosmic origin of octagonal shapes is until today the so-called **pat kua mirror**, which even right now is considered by Chinese people to display various supernatural and magical powers originating from cosmos. Therefore the sole fact, that the artefact discussed here has an octagonal base so clearly visible on "Figure #B3" and "Figure #C1", should be interpreted as the strong message passed to us by builders of this device. This message is trying to convey to us, that this particular device does NOT originate from Earth, but it has a cosmic origin.

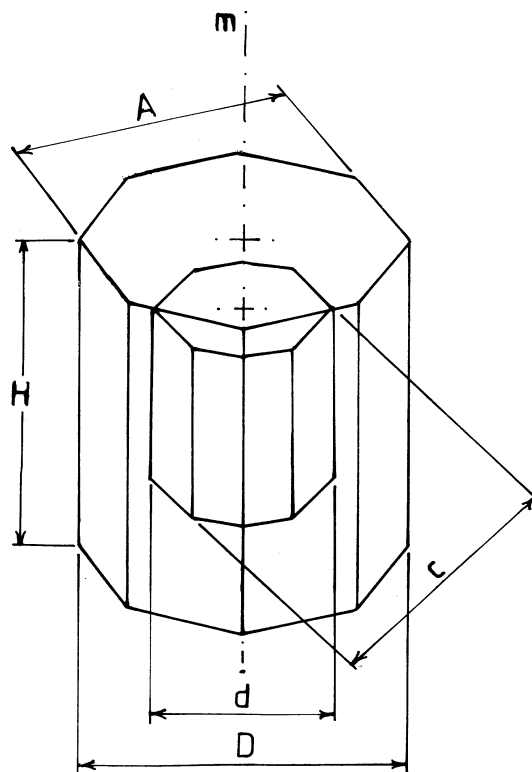

Fig. #C2: This is how the device called the "Oscillatory Chamber" looks like.

(The dimension lines shown on this device indicate the geometrical parameters of it, as explained in "Figure F8 (2s)" from volume 2 of my newest [monograph \[1/5\]](#) - available free of charge via this green link.) This extraordinary device is used by UFO vehicles of the second generation for producing a powerful telekinetic field, which (1) propels these vehicles, (2) makes them invisible to human eyes, and (3) allows them to pass through walls without damaging these walls or UFO vehicles. Because this advanced device has an octagonal cross-section, the pillars of telekinetic field that it yields from the outlet directed downward, is also octagonal in a horizontal cross-section. So columns used to support ceilings in some Christian churches, which try to mimic the pillars of such "supernatural" telekinetic field, also display octagonal cross-sections in horizontal planes. Notice that operation of the Oscillatory Chamber is described in volume 2 of my two monographs, namely my newest [monograph \[1/5\]](#), and my slightly older [monograph \[1/4\]](#) - entitled "Advanced Magnetic Devices", the text of which can be downloaded free of charge from numerous web pages listed in Menu 2. In turn properties of the telekinetic field that such Oscillatory Chambers generate are explained in volumes 4 and 10 of the same monograph [1/4].

Because base of the replica of the "Zhang Heng seismograph" presented here is shaped into an octagon, it tries to tell us in a symbolic manner that it originates from cosmos, NOT from Earth.

#C3. The shaping of objects into octagons was intended in old times to symbolise their cosmic origin:

People abducted to UFO vehicles keep reporting about strange devices that they almost always see inside of these extraterrestrial vehicles. Most prominent amongst these devices most frequently take the shape of an octagonal transparent "crystal". However, sometimes it can also be shaped as a transparent cube, or as a sixteen-sided "crystal". If it is sixteen-sided, it looks almost like circular, but with an uneven surface. As it turns out, these strange crystals seen on decks of UFOs are simply "[Oscillatory Chambers](#)" that UFOs use for the propelling purposes (the general appearance of such an Oscillatory Chamber is shown in "Figure #C2" below). People abducted to UFOs seem to be fascinated by these Oscillatory Chambers. The reason is that these extraordinary devices contain millions of "alive" sparks inside, and also that they emanate an enormous power. So when these UFO abductees return back to Earth, they duplicate shape of these fascinating devices in numerous objects, especially those used for worship or for magic.

Strangely enough, if one reviews human cultures, it turns out that almost all mysterious objects somehow connected with cosmos, mystery, or with worship, are always shaped into one of shapes that mimic these Oscillatory Chambers from UFOs. Thus, most frequently such objects are shaped into octagons. If they

are not octagonal, then they are either square, or almost circular in shape (or more strictly 16-gonal). In turn, practically never six-sided shapes are used for worship or for magical purposes, although six-sided shape could be constructed most easily.

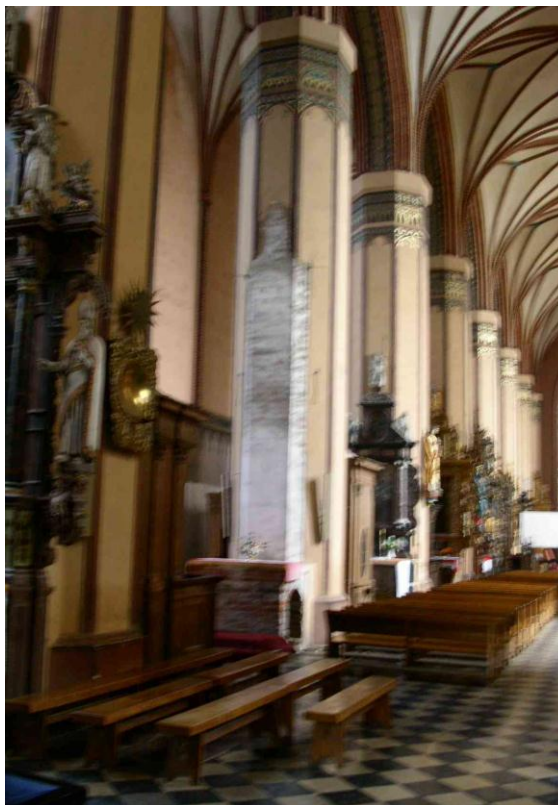

Fig. #C3: Eight-sided columns that support the ceiling in the Frombork cathedral from Poland (that one in which the famous astronomer, Nicolas Copernicus, used to work).

Photographed by the author of this web page in July 2004. Similar octagonal columns are also present in many other old Polish churches constructed before 15 century. Their curious aspect is that their design and appearance closely imitates the eight-sided columns of powerful telekinetic field that emerges from the outlets of the octagonal Oscillatory Chambers from UFOs.

The shocking aspect of all columns in old Christian churches is, that these columns use only four different shapes, all of which imitate shapes of columns of telekinetic field that emerges from UFO propulsors. And so, these columns can either have (1) square cross-section, or (2) octagonal cross-section, or (3) sixteen-sided cross-section, or (4) rounded cross-section (such rounded cross-section is an approximation of sixteen-sided cross-section). **As so-far, I never met in any church in the world a column that would have e.g. triangular or six-sided cross-section, in spite that such columns would be the most easy for construction by old masters.** (From the point of view of constructing a column, it is incomparably more difficult to measure and to build a column with an octagonal cross-section, than a column e.g. with six-sides. After all, in order to measure an ideal six-sided figure, it is enough to place six radiuses around peripherals of a circle. But to measure an ideal eight-sided figure, one needs extremely precise and complex measuring procedure and advanced geometrical knowledge. So there must exist a very important reason, why old masters

constructed eight-sided columns in churches, instead of six-sided. On the basis of my research to-date, this very important reason was to imitate in churches the interiors of UFO vehicles, in which ancient UFO abductees could actually see octagonal columns of telekinetic field yielded by Oscillatory Chambers of these vehicles.)

Part #D: Mysterious model of the "telepathic telephone" from the church of Mother Mary in Gdańsk, Poland:

#D1. In the church from Gdańsk, Poland, there is a mysterious "composite device", the details of which suggest, that the goal of it is to model, or even to replicate, an ancient "telepathic telephone":

Motto: "The existing evidence conclusively confirms that God made sure that every groundbreaking technical device which is to decide about the fate of humanity has appeared on the Earth in ancient times, and that the knowledge about the design and operation of this device continually inspired people until the time when the humanity is to learn how to build this device."

In the Virgin Mary Catholic Church from the Polish city of Gdańsk (called also the "Basilica of Concathedral of the Assumption of Mother Mary from Gdańsk", or the "church of the Virgin Mary"), soon after the World War Two was juxtaposed a configuration of mysterious religious artefacts shown below in "Fig. #D1". This configuration was juxtaposed supposedly "at random" from medieval artefacts that survived the devastation of war and that originated from two different churches, i.e. juxtaposed from fragments of the original baptistery that was already in this Gdańsk Basilica since it became consecrated in 1557, and from the font of 1682 that was shifted to this Basilica after the war from another church of St. John in Gdansk. But we should not be misled by this supposedly "random" composition of this device. After all, **"in the world created and intelligently governed by omnipotent God"**, in which world we live (as tries to reveal this to us, amongst others, the formal scientific proof from items #B1 to #B3 on the web page named [changelings.htm](#)), does NOT exist such a thing as a "random coincident". Everything that in this God's world happens supposedly at

"random" or by an "accident", in reality is wisely pre-planned and foresightedly implemented by omniscient God who NOT only knows the entire past, but also the future. Therefore, my analyses, results of which I am trying to present on this web page, suggest that the configuration of this "composite device" from Gdańsk in Poland was intentionally so designed by God (although made with hands of people inspired by God), that it fulfils a very important function of inspiring the development of science and technology on the Earth. Namely, in my opinion (which opinion I am going to justify in this "part #D" of the web page), the configuration of this "composite device" from the church in Gdańsk, Poland, has the goal to inspire people, who know almost nothing about telepathy, to build a working prototype for a new kind of "analogue telephone" in which (telephone) the functions of the carrier of voice conversations are to be fulfilled by telepathic waves. In order to fulfil such an inspirational function, and at the same time to NOT take away from anyone his or her "free will", but to allow everyone to have an own interpretation of this supposedly "assembled at random" technical device, God intentionally gave to its formation the characteristics explained in more details in item #C2 from the totaliztic web page named [tornado.htm](#). Namely, God so designed origins of the configuration of devices discussed here, that: **(1)** atheists consider this configuration to be a result of a "blind action of a random coincident", means to be a result of an accidental and natural action of the human author of this configuration, **(2)** historians and people seeking an inspiration in technical achievements of antiquity could believe that this configuration is the result of the restoration (replication) by the human author of it, an ancient device about which this human author knew, or heard of, that in the distant past it acted as a "telepathic telephone" (I would NOT be surprised at all, if ancient remains of just such an existing telepathic devices were discovered somewhere soon), in turn **(3)** those who believe in God, or who know for sure (like myself) that God does exist, considered this configuration to be what I am explaining in this "part #D" - namely, to be a model and an inspiration for the "telepathic telephone" given to the humanity (or more specifically - to the Polish Nation) by God, through inspiring me ([i.e. Dr Eng. Jan Pajak](#)), to firstly recognise the uniqueness of this device immediately after I saw it for the first time, then to photograph it and thoroughly examine this "composite device" during my visit in Gdansk in 2004, and finally to **"invent"** the operation and the design of the "telepathic telephone" from the very beginning in 2013 without re-examining it - i.e. just due of being inspired by the appearance of this Gdańsk's device and because I previously accumulated the required knowledge about the work of telepathic waves and telepathic devices. In descriptions from this "part #D" that are to follow, I am to try to justify my belief that the "composite configuration" described here is a wise "gift" donated to us by God and aimed at inspiring and providing a model for a "telepathic telephone" - but about which probably one day is to turn out that it is also a replica of an ancient telepathic device which in past was built and existed, only that, as all the ancient wonders of technology, it later fell a victim of human forgetfulness.

On the occasion of this description I should also bring again the reader's attention to what is explained in my autobiography, namely, how big **waste** of my creative capabilities, "special directing", and the knowledge that I was blessed with, is this loud spitting, humiliation, mockery, criticizing and ignoring of products

of my creative searches for truth that are going-on throughout the entire my live - with the silent approval from my countrymen. After all, these are such attitudes and condemnations from other people which cause, that in spite of many repeated efforts and appeals - of the kind described e.g. on the web page named [job.htm](#), in item #11 from the web page named [seismograph.htm](#), or in [my autobiography](#), that so-far disallowed me to complete even a single one amongst my numerous inventions and to put it into a service for the humanity. On the other hand, when I'm gone already, other people NOT so gifted by God with creative abilities similar to mine, are going to have "hard nuts to crack" and laborious searches to complete, if they wish to implement any amongst my numerous inventions, without being able to consult what they do with the body of knowledge accumulated in my mind and without my creative thinking.

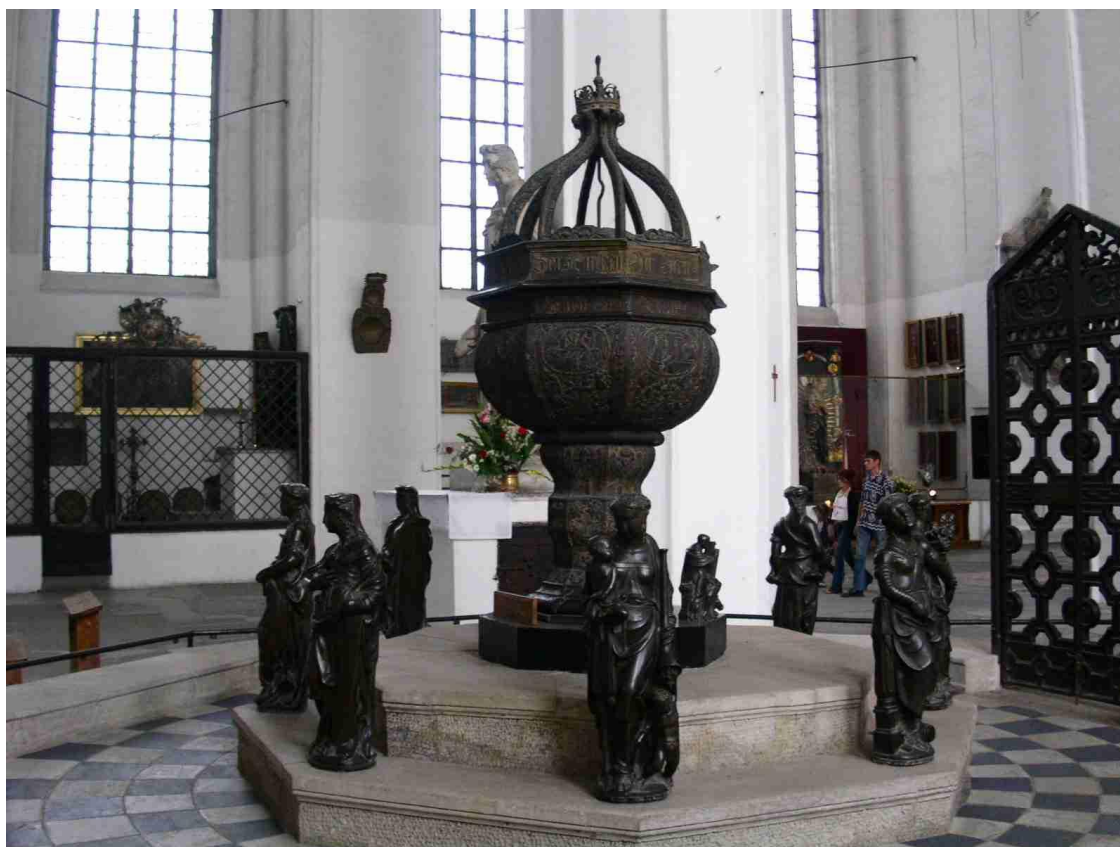

Fig. #D1: A gigantic, mysterious, octagonal "composite device" from the St. Mary's Catholic Church in Gdańsk, Poland. We should not be misled by the supposed "random piecing together" this device from two separate religious artefacts (i.e. the composing it from the baptismal font of 1682 that originated from another Gdańsk's church of St. John, and from a few fragments of the former St. Mary's Baptistery cast in 1556, such as the eight figures of the virtues, plinth, gateway, and two out of the four evangelists). The various features of this device described in this "part #D", suggest that its configuration and meaning are NOT coincidental, but that it is supposed now to fulfil the well-defined functions of inspiring a technical and scientific progress.

(This device is also described on several other totaliztic web pages, for example in item #D18 and in the caption under "Fig. #D18" from the web page named [milicz_uk.htm](#), and also in item #D16 from the web page

named [wroclaw uk.htm](#).) The above photograph was taken in July 2004. This device shown on it is so huge that eight female figures of the virtues that are standing around the octagonal base (floor) has a size of adult humans - which further strengthens its intended function as an illustrative model for the "telepathic telephone" (after the clicking on the above image the reader can compare the size of these eight figures of virtues with size of two tourists photographed on the background behind the sculptures). The original purpose of this device remains a true mystery. After all, it is too huge to perform any practical functions - beside decorating or working as a container for holy substances. However, it is strikingly similar to the telepathic so-called "[Zhang Heng Seismograph](#)" - as the reader may realize this by comparing the above image of the device (i.e. the "Fig. #D18"), with numerous photographs of the "Zhang Heng Seismograph" shown here in "Fig. #B1" and "Fig. #B2", and also on the entire web page named [seismograph.htm](#). In turn this "Zhang Heng Seismograph" was an ancient telepathic apparatus, which utilised properties of telepathic waves for early warning people about impending earthquakes. For this reason, and also because of the various features of the shown above "composite device" from the Church of St. Mary in Gdańsk, Poland, the author of this web page believes that this apparatus is to perform the function of stimulating the development of science and technology, and for this reason, it probably is even a replica (a copy) of an ancient "telepathic telephone" that already has been built - i.e. the replica of a telepathic communication device which allowed to conduct remotely a voice conversations through two or more such devices positioned at considerable distances from each other. (I.e. this "telepathic telephone" was an ancient telepathic equivalent of today's "mobile phones".) More on this topic explain further items from the whole this "part #D" of the web page.

(Note that the extraordinary "Zhang Heng Seismograph" utilised [telepathic waves](#) for remote detection of impending earthquakes ahead of time to allow for an effective escape from the danger zone. The mysterious operation of it today cannot be recreated in a working device). In turn the above mysterious device also not only that has not an octagonal shape of the main body, but also an octagonal base - just like the Zhang Heng Seismograph described on the above web page. In addition, the general appearance and shape of it are strangely similar to the shape and the appearance of that Zhang Heng Seismograph. But instead of wrongly attribute the source of these similarities to inter-cultural and inter-religious influences, the more rational is to realize, that both these devices: **(1)** have the shape and structure which suggest that they are devices which utilize telepathic waves in their operation, **(2)** that they both are copies or models of some already constructed, existing and used in antiquity telepathic devices, and **(3)** that they mimic the shape of main propulsors from UFOs (together with telepathic functions of these propulsors). To such conclusions leads us the knowledge that inside of these propulsors of UFOs of the second generation, octagonal oscillatory chamber shown here in "Fig. #C2" are contained, which are very similar to the shapes presented on the above image. Our churches are full of strange objects, the appearance of which imitates the

shapes of devices seen on decks of UFOs by people abducted to these space vehicles. For descriptions of the design and operation of the Oscillatory Chambers from UFOs, see web page named [oscillatory chamber.htm](#), or see volumes 2 and 17 from my newest monograph [1/5] (including the Figure F8(2s) from that monograph [1/5]). The above realizes that a huge number of various octagonal objects existing in the human culture, actually results from imitation by old masters of the shape of octagonal Oscillatory Chambers from UFOs.

I wonder if anyone ever analysed why in churches, mosques, and temples of other religions, almost everything imitates a very difficult to accurate production octagonal shapes of UFO propulsors, or octagonal outlets from UFO propulsors, in spite of the fact that all church objects could be constructed in a countless number of other shapes. The answer to this is, that people are abducted to UFOs from the early days of the Earth, and upon returning to the Earth they mimic in their creative products fascinating devices that they saw during these UFO abductions. (The reader may find more information about UFO in web pages listed in "Menu 4", for example in the web page named [ufo proof.htm](#).)

#D2. How the device discussed here models and inspires the work of "telepathic telephone":

On the basis of whatever the author of this web page already knows about the phenomenon of telepathy and about principles of operation of telepathic communication devices, he is able to predict (or more strictly, "**invent**" **again** from the very beginning), how the prototype of analogue "telepathic telephone" is to work in the future. (The author calls this his "invention" a "prototype", because in the first construction it will probably have rather "large" dimensions, i.e. the same big size as the size of the device described here from the church in Gdańsk, Poland. Only in later versions, that are to be produced after a full understanding of its principles of operation and phenomena taking place in it, it will be miniaturized to small sizes.) The principle of operation of this his "invention" of the prototype of such a "telepathic telephone", the author is to describe here in this item. He recommends the reader, that while reading the description that follows, at the same time the reader directs his attention at the compatibility of this principle of operation with the "model" of the described here "composite device" from the church in Gdańsk, Poland. Here is the description of the principle of operation of an analogue "telepathic telephone":

Two (or more) identical such "telepathic telephones" are positioned in a large (almost any) distance apart. People that are to converse remotely with each other via these telephones, are standing in precisely determined points on a straight line connecting the two devices, so that their backs are turned towards each other. The positions in which they are to stand are imitated by female figures of "virtues" in a configuration of the model from the Polish church in Gdańsk. The voice coming out from the mouth of each of these mutually conversing people is

reflected by a large "voice mirror" - means by a kind of dome or a dish that focuses the voice vibrations from the talking person onto the "telepathic microphone/speaker" suspended in the middle of the central octagonal container whose sides are curved into shapes of the satellite dishes pointed exactly at other similar "telepathic telephones" with which users of a given telephone carry out a voice conversation. (The functions of just such "voice mirror" can perform e.g. a properly curved and positioned dome of the church's roof, or kinds of concave bowls similar to the ones from "Fig. #D2", that are build-in to walls which surround the "telepathic telephone" described here.) In the voice-sending "telepathic telephone", the "telepathic microphone/speaker" (whose function can successfully be performed e.g. by a large "quartz crystal" (Q) described and illustrated, among others, in the web page named [fe_cell.htm](#)), converts speech vibrations into telepathic vibrations, while in the receiving "telepathic telephone" it works in opposite direction, means it converts telepathic vibrations into sounds. These telepathic vibrations produced by the "telepathic microphone" are reflected by the satellite-antenna-shaped and appropriately targeted central octagonal copper container, in the result of which reflection these telepathic waves are transmitted along straight lines and arrive, among others, to the inside of the second (receiving) such a communication device. There again, they bounce off the side of a curved like a satellite dish, central copper container - which focuses these telepathic waves on the "telepathic speaker" from this second device (i.e. on another equally large quartz crystal "Q" with natural frequencies of its telepathic vibrations harmonically-identical to these from the crystal (Q) in the first device transmitting a given speech). This second "telepathic microphone/speaker", marked here "Q", changes the telepathic vibrations back into the voice vibrations of the air - means turns telepathy into voice. But this voice is too weak for the other person to hear it - because it diverges from the quartz crystal "Q" into all possible directions. Fortunately, this second device is also positioned close to yet another "voice mirror" similar to the mirrors captured on the photograph from "Fig. #D2". This yet another "voice mirror" captures faint voice vibrations radiating from the associated "telepathic microphone/speaker", then focuses these vibrations onto the ears of the other participant of the conversation. That their focusing reinforces the voice, causing that the speech becomes audible to the other party in such a remote conversation. In this way, whatever says one of the people conversing with each other with the help of a pair of such "telepathic telephones", the other person instantly hears it - and vice versa. Of course, a greater number of such telepathic telephones allows that more than two people (i.e. in the versions shown in "Fig. #D1" - up to 8 people) simultaneously take parts in a remote discussion with each other.



(a)



(b)

Fig. #D2ab: Dr Jan Pajak (i.e. the author of this web page and the "inventor" of the "telepathic telephone" described here), photographed by the "air telephone" - that is, by a kind of "telephone" in which speech is transmitted through the air in the form of beams of voice vibrations. The photograph was taken on 13 March 2006 at the entrance to the museum located in the city of Dunedin, New Zealand - where this "air telephone" was installed for fun of children and for experimentations of adult visitors to that museum. The principle of this "air telephone" is based on two concave "voice mirrors" that reflect in the desired direction and focus on each other the voice vibrations formed by people "talking" via this telephone. What in this telephone is very intriguing, is that it NOT only transmits the voice, but also strengthens its energy. Thus, for example, "whispers" by the sender, the recipient receives as almost a "scream". Just such "voice mirrors" as those shown in the above photographs are to also be needed in the "telepathic telephone" described here, to reflect and to focus on the "telepathic microphone/speaker" and then on the listener's ear, the voice vibrations transmitted by this telepathic telephone. Only that the functions of such "voice mirrors" can perform either appropriately designed concave walls behind talking people, or appropriately designed curvatures of domes (ceilings) in buildings which are installed such "telepathic telephones" (e.g. ceilings formed into the shape of a slightly deformed domes that exist in many old churches). (Click on any of the above photos to see them enlarged or to shift them to other area on the screen.)

Fig. #D2a (left): The general appearance of the two concave bowls of the "voice mirrors" that reflect and redirect the speech in the "air phone" shown here. These are at least two such mirrors that will have to be present in the operation of an analogue "telepathic telephone" for implementation of the principles of operation described in item #D2 from this web page.

Fig. #D2b (right): The principle of reflection and concentration of voice waves used in the devices described here, requires that the voice was coming

out, and was received, in strictly defined points. In the "air telephone" shown in the photograph from this part "b", getting the effect of sending and receiving a speech in a strictly defined point is obtained due to the requirement that the sender and the recipient place their mouths and ears to that ring which I hold by my right hand. But in the discussed in item # D2 principles of the telepathic telephone, the same effect is achieved by the requirement that the sender and the recipient must stand in the exactly defined places of two "telepathic telephones" that they use, namely in places which in "Fig. #D1" are illustrated by positions of the human sizes statues of female "virtues".

* * *

Since the time of taking the above photographs I have NOT been re-visiting the New Zealand city of Dunedin, in which the "air telephone" shown here was then available to experiment on by the interested people. So I do NOT know whether this "air telephone" is still in there and it still works. This is pity, because if it still was in there, then I would recommend to interested researchers of the "free energy" to go to Dunedin and to "early" (instead of "with own eyes") see that this overrated by the old official "atheistic orthodox science" the so-called **"energy conservation principle" is NOT working for some vibratory phenomena**. It is so, because if this principle is fulfilled for all vibrations, then the volume of the received signal from the above "air telephone" could NOT be higher than the volume of the send signal from the same telephone. After all, as we know this from today's construction of speakers, the volume is actually proportional to the energy of the audio signal. But the above "air phone" proves to "ears" of the listener that the volume of the received audio signal can be many times greater than the volume of the send signal (e.g. the whispering issued by one of these "voice mirrors" is received at the second mirror as a loud scream). In turn, such an evidence for a non-compliance of selected vibratory phenomena to that vaunted "energy conservation principle" is an excellent experimental news for people working on the so-called "free energy devices" - i.e. on devices described, for example, on totalistic web pages named: [telekinetics.htm](#), [free energy.htm](#), [fe cell.htm](#), [eco cars.htm](#), or [boiler.htm](#). After all, the "vibrations" are one amongst those "winds" still unknown exactly to the official science and described e.g. in item #B2 from the web page [telekinetics.htm](#) - the proper utilisation of which "winds" will allow in the future to effectively "propel" with them the ever working "free energy devices".

#D3. Is this mysterious telepathic device from the church in Polish Gdansk in fact a replica of ancient "telepathic telephones"?

In ancient times, the mankind had technical devices that until now amaze us with their unheard scientific and technical sophistication. For example, the previously described so-called "Zhang Heng Seismograph" still exceeds the present level of knowledge by at least 100 years. Other devices also extremely

advanced technologically (e.g. the so-called "**Amphora from Pakistan**" - which warmed water without drawing nor consuming at the same time any energy) is described in item #E4.2 from the web page named [boiler.htm](#), as well as in item #H3 from the web page named [newzealand visit.htm](#).

If we analyze the entire information which is now available on the subject of "composite device" from the Polish city of Gdańsk, shown above in "Fig. #D1", then it turns out, that this device (and its fate) follows a kind of "standard scenario" which we know from the history of other "miraculous" apparatuses of antiquity. **This "scenario" was deliberately designed by God in such a way, that even after the a working prototype of the future "telepathic telephone" is build and started to be used in the future, still the device from Gdańsk does NOT deprive anyone of his or her "free will" and does NOT change his or her beliefs and views.** Therefore, for example, **(1)** people who believe in "random coincident", even after a building of a working prototype of this device still will be able to maintain their certainty that the configuration from the Polish city of Gdańsk was just a work of "coincidence". In turn e.g. **(2)** people that believe e.g. in "ancient astronauts", or in existence of civilisations in the Earth's distant past, that were more advanced than our present civilisation, still are to maintain their belief that the apparatus from the Polish city of Gdańsk was "assembled together" by its designer just in such a way, because this designer knew or heard of a similar miraculous apparatus that existed somewhere in antiquity. Furthermore, **(3)** people who believe e.g. in what I wrote on this web page, also will then be able to get confirmation for their beliefs after a working prototype of this device is finally constructed.

The effect of NOT taking away the "free will" from people, even when the working prototype of the "telepathic telephone" is build, would only be additionally reinforced, if old "artefacts" would be found somewhere, which would confirm that in antiquity such telepathic telephones were already build and used on the Earth. After all, such old "artefacts" would additionally enforce beliefs of all three main categories of people listed above. Therefore, I personally would NOT be surprised, if remains of such an ancient apparatus soon were discovered somewhere. After all, such remains would empirically revealed the highly ambiguous fact, that the configuration from the Polish city of Gdańsk in some way copies or replicates an already built and existing in past (i.e. working in antiquity) set of just such devices.

To be honest, even right now I myself know devices still existing in several old churches, which can be just medieval copies or replicas from ancient "artefacts" even older than they, and which (artefacts) in ancient times were used just in functions of such "telepathic telephones". This device already known to the author, is the so-called "**confession**" shown below in "Fig. #D3". Actually, everyone can have a good look at such "confessions" still existing until today in several amongst old churches. After all, such a "confessions" are present until today, for example, in the Polish cathedrals from Gniezno and Kraków, and also in the St. Peter Basilica in Rome. In 1995, I myself saw such a "confession" in the church from Warsaw, Poland, located by the Polish President's palace (which church at that time was clearly shifted miraculously from somewhere to Warszawa just for the duration of my visiting it) - as I described this in more details in item #D6.1 from the web page named [timevehicle.htm](#) and in items

#E3 to #E4 from the web page named [malbork uk.htm](#). There is several reasons for which I believe that these "confessions" from medieval churches in fact are copies or replicas from originals of "telepathic telephones" that were even older than these confessions are. I am going to list here at least most important amongst these reasons. Here they are:

1. The similarity of these "confessions" to the so-called "[Oscillatory Chamber](#)" and to the "main propulsor" from the spacecrafts which I invented myself, and which are called the "[Magnocrafts](#)". On the other hand, I already know for sure about this main propulsor from the Magnocraft (which, of course, I know extremely well, because I invented it myself) that independently from its functioning as a propelling device, in the future it will also perform various communicative functions based on telepathic waves - in this number the function as a "telepathic telephone". For many years now, I also explain these communicative functions of the main propulsor from the Magnocraft in my numerous monographs - for example, see subsections G1.5 and G1.6 from volume 3 of my newest [monograph \[1/5\]](#), or see subsections F1.5 and F1.6 from volume 3 of my slightly older [monograph \[1/4\]](#), or see subsections F1.5 and F1.6 from chapter F of even the oldest Polish [monograph \[1/3\]](#) still present amongst my publications circulated on the internet.

2. The containing of all key components of the "telepathic telephone". In addition to the above purely theoretical knowledge of the "confessions", in that year of 1995, with my own eyes I saw also empirically, that typical "confessions" contain in themselves all vital components of the "telepathic telephone" described here in item #D2, including a huge quartz crystal-resonator "Q" located in the centre (which crystal "Q" in the confessions takes the shape of a "sarcophagus" or a "marble coffin"), and also including a large "voice mirror" hanging above that crystal - which "mirror" in the typical "confessions" takes a form of the "baldachin" supported by four twisted columns. It is pity that I do NOT have the required funds, nor an official status, to research these "confessions" and to e.g. check whether by a chance their work as "telepathic telephones" survived until today in their medieval copies, or replicas, and also to explore where were located the originals which these "confessions" imitate (after all, these original devices would be "artefacts" of the original "telepathic telephones" the remains of which, according to the certainty which I gained during my sleep, survived somewhere until today).

3. The significance of inconsistency between the destination of "confessions" and the meaning of their name. The word "confession" comes from the Latin word "confesio". According to [various dictionaries](#), the meaning of the word "confession" is typically defined somewhere along the lines: **reporting to the appropriate authority about one's doings**. This meaning perfectly reflects the functioning of the objects named "confessions" in the role of "telepathic telephones". On the other hand, this particular word is assigned for naming "tombs of believers". Thus, to me such an assignment looks as a kind of deliberate "masking" of what "confessions" actually hide from people who are morally NOT mature enough for the honour of building and having "telepathic telephones". (Notice that a similar "masking" hits also our eye e.g. in the [content of the entire Bible](#).)

In the same way as finding an "artefact" of the device discussed here would NOT deprive anyone of his or her "free will" - even when a working "telepathic telephone" is already built, also the described here **history of my "invention" of this device is NOT taking away the "free will" from any of the existing categories of people**. After all, for example, **(1)** atheists and people who believe in "coincident", even after the "telepathic telephone" is constructed (my "invention" of which phone is described here), still will continue their beliefs that my invention and the circumstances of it, were just the result of accidental convergence together of the image from Gdańsk's device (which image resided in my subconscious), with my in-depth knowledge of the work of telepathy and the work (in the role of telepathic transmitters) of main propulsors in the Magnocraft vehicles which I invented. In turn, for example, **(2)** those people who believe in the ancient civilizations still would believe that my invention was a mere reproduction or recalling of the device that I have seen, or perhaps even that I built and used myself in one of my previous incarnations. Also **(3)** those people knowing for certain about the existence of God, or people strongly believing in God, still would believe in what I also believe, namely that God "gave" me the "invention" of this telephone during my sleep during the night of 9th to 10th January 2013. I should also add here, that my research on methods of God's work, reveal that if something creates so much ambiguity and so many possible interpretations - all of which are well serving towards preserving "free will" by people, then God chooses that just this is confirmed in the real life. Only that God provides the confirmation of it in the time chosen by Him, not by us, and that **the implementation of the confirmation God always controls along the "line of the highest error" - which is also the "line of the highest teaching effect"**.

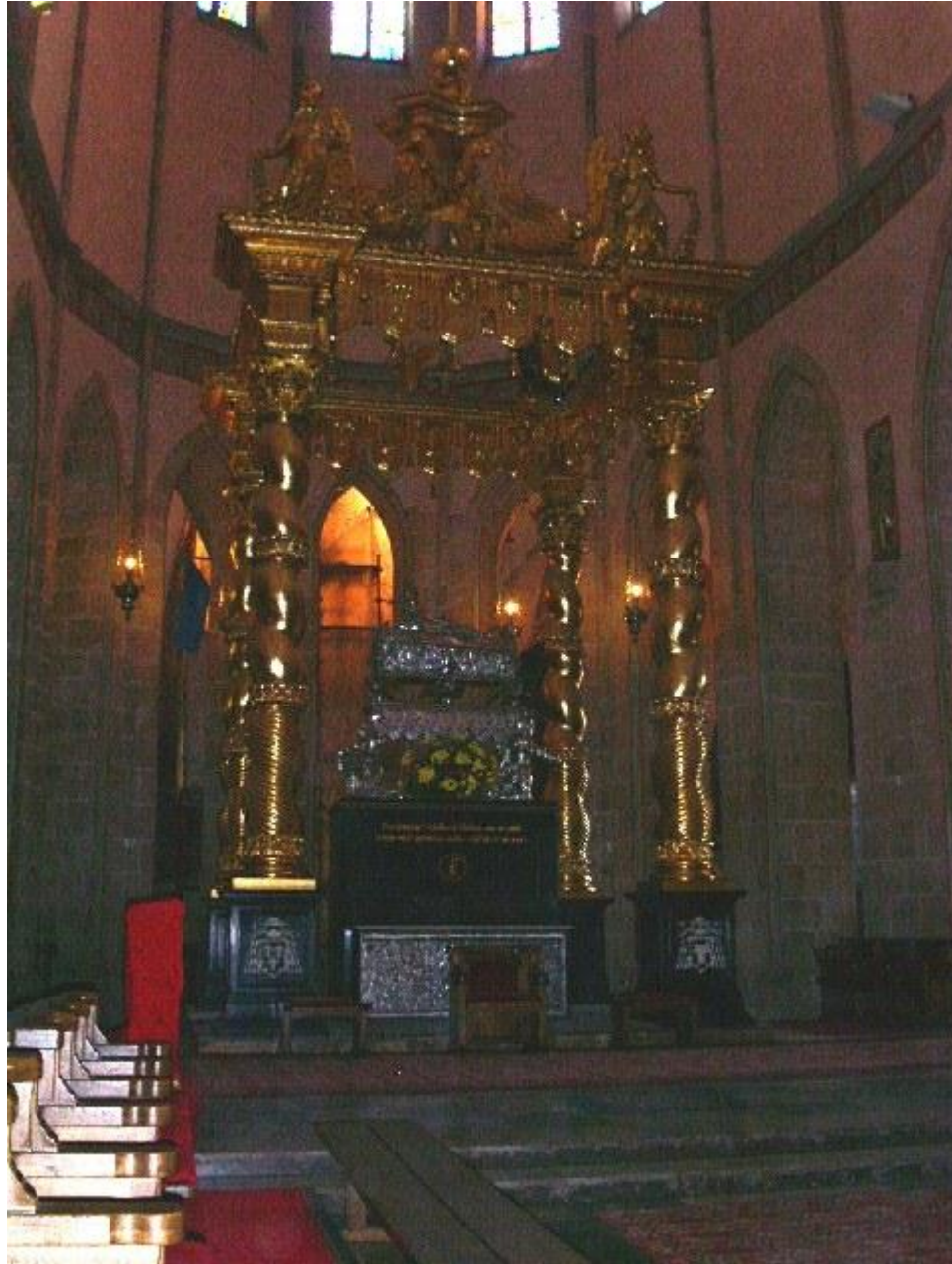

Fig. #D3: Here is a photograph of the so-called "confession" from the cathedral in the Polish city of Gniezno, taken in 2004. It is the only photograph of "confessions" which at the moment is in my possession. That is why I am showing it here - although neither the quality of the above photograph, nor the technical faithfulness of the device recorded on it, are at the best level. The author of this web page suspects, that just such "confessions" (still existing in several ancient churches from Poland), in fact are more or less faithful copies of the much older "artefacts" which in ancient times were used as "telepathic telephones" described here. Actually many of these "confessions" still to this day contain all the basic components required for the work of such "telepathic telephones". Unfortunately, in the "confession" from the Polish city of Gniezno (this photographed above), the "voice mirror" (baldachin) is missing. But such a "voice mirror" (baldachin) I noted myself that it exist in the "confession" from St. Peter's Basilica in Rome, as well as in the "confession", my sighting of which was mysteriously granted to me in 1995 in a church from Warsaw (and which most probably was then temporarily moved to Warsaw from the place in Poland named

"Święta Lipka") - as described on my web pages indicated and linked above. (Click on the above photograph to see it enlarged or to shift it to other area of the screen.)

#D4. A review of potential benefits, that the humanity may gain from my "invention" of the "telepathic telephone" described here:

My "invention" of the "telepathic telephone" described here was actually "given" to me in a manner that disperses any doubts, because I received it in circumstances that completely contradict the logic. In days just before I went to bed in the evening of 9th January 2013, I did NOT think about anything associated with this telephone, nor even did NOT carry out any research or thinking that would be associated with the phone. In spite of this, when I woke up from a dream still a long time before the morning of 10th January 2013, in my mind I already had very strong feelings, **(a)** that I know how the "telepathic telephone" is to work, **(b)** that this mysterious device which I photographed a number of years ago in the church from Polish Gdańsk is the "model" of such a "telepathic telephone", **(c)** that in ancient times existed on the Earth and were used just such "telepathic telephones" - only that the knowledge and memory about them has been lost over time, **(d)** that remains (artefacts) of these ancient "telepathic telephones" exist on the Earth until today, and **(e)** that the entire knowledge that was "given" to me during the sleep that night I should now write down exactly on one amongst my web pages - so that from now on all interested people could start inspecting it and implementing it in the real life. I personally believe, that this strong feeling of "receiving" the above knowledge awakened me from the sleep that night. So after waiting until the morning comes, I started to quickly write down all this knowledge, to NOT forget anything. When I was writing it down, I still did not know about a few important details, for example about the fact that the "model" of this device from the church in Polish Gdańsk is a "composite", NOT a homogeneous whole, and thus that just by itself it is NOT a model of the physical device that existed in antiquity. (Together with the certainty which I gained during my sleep, that "artefacts" of such devices still exist on the Earth until today, the above practically means, that "artefacts" which represent the original, operating, ancient design of such a "telepathic telephone" still have to be found by a researcher devoted to this matter. In turn, as I already explained this in item #D3 above, I myself suspect, that these "artefacts" are so-called "confessions" which until today exist in several very old churches.)

When later I began to wonder about the reasons for such a non-conventional "giving" to the humanity, via myself, the "invention" of the "telepathic telephone", I easily understood that there is a lot of such reasons. Let us write down most important amongst them. Here they are:

(1) The illustrating that God strictly controls and inspires inventions and discoveries, and also that "inventions" and "discoveries" are actually "given" to individuals which are carefully selected for this purpose, so thus they cannot be accomplished only because someone "wants to be an inventor". (Although in order to "receive" an invention or a discovery, one firstly must prove that deserves it, by contributing a type of work, which is related to a given invention or discovery and which on the inventor or discoverer himself typically makes an impression, that it is him or her that accomplished it. This impression is so strong, that until 9/10th January 2013, when I "invented" the "telepathic telephone" described here, I was sure that all my numerous inventions and discoveries were accomplished exclusively because my own hard work, my creative manner of thinking, and a huge amount of "all round" knowledge which I accumulated in my life.) This actual, although carried out discretely, "giving" of inventions and discoveries by God, and their "receiving" only by carefully selected people, explains many facts previously unrealised by the humanity, and ignored by scientists. For example, it explains why inventions and discoveries appear only in countries and amongst nations which display the level of "morality" required by God. (This means also, why in all "highly immoral" countries and nations, prevails darkness, stupidity, ignorance, and the so-called "**inventive impotency**" - described, amongst others, in (2) from item #H4 of the web page named [quake.htm](#).) It also explains why females very rarely become inventors or discoverers - for correct source of such rarity see item #B2 on the web page named [antichrist.htm](#). Furthermore, it explains why **all the "inventors" and "discoverers" of something truly new and progressive have to be people highly "moral"**, and why "immoral" people are never able to creatively develop anything really new, means why "immoral people" never become true "innovators" nor "discoverers" - as it is explained in item #H1 from the web page named [boiler.htm](#), or in item #D6 from my autobiographical page named [pajak jan uk.htm](#). (Although in past there was a lot of cases when "immoral people" stole inventions and discoveries from their truly moral colleagues - but all such cases of historical cheating are slowly coming up to the knowledge of humanity - some amongst them are described in items #11 to #15 from my web page named [mozajski uk.htm](#).)

(2) The indication of the need for an active search of artefacts of ancient versions of the "telepathic telephone". When the "invention" described here was "given" to me, also "given" to me was the certainty that such "telepathic telephones" existed already in ancient times, and were used on the Earth. Only that with time they fell into oblivion. So now someone just needs to find their remains, which exist somewhere on the Earth until today. As I already explained this previously, these searches can be started from careful researching of so-called "confessions" from old churches - about which may even turn out, that after a correct carrying out required experiments on them, they even today may still work as such "telepathic telephones".

(3) The familiarising people with features, performance, and methods of utilisation of telepathic waves. This in turn opens to the whole of humanity the doors to an ocean of future technical applications of telepathy - including these ones that are described on the page named [telepathy.htm](#).

(4) The teaching to people of the most simple principle of operation and

design of a telepathic communication device - which a device, after the miniaturization, will be able to replace today's "mobile phones" and eliminate their disadvantages and destructive "side effects". For example, "telepathic telephones" will eliminate such drawbacks, as limitations of the range, screening the access by metals, and several further ones. In addition, they will be able to eliminate the still denied by well-paid "experts" risks of inducing cancer in people who are using too-often present cell phones, eliminate the stubbornly ignored by the official science the destruction of bees caused by mobile phones and described e.g. in item #C5.1 from the web page named [newzealand.htm](#), etc.

(5) The providing of previously unknown empirical evidence for the future development of a whole range of new technologies - for example the development of these so-called "free energy devices" based on gradually detected circumstances in which the "over-advertised" by the old "atheistic orthodox science" misleading "energy conservation principle" stops working. (For example, the author of this web page is already aware, that the **"principle of energy conservation" ceases to work for all telekinetic phenomena, for telepathic vibrations, and in cases of some transformations on physical vibrations - for example during spreading and condensing of voice vibrations, such as these described in caption for "Fig. #D2".**)

#D5. The inspiring role of the "invention" of the telepathic phone described here:

On basis on my bitter experiences from the past, I am fully aware that my "invention" which is described here, similarly like everything that I have done and wrote in my busy life, will also be received with a loud noise and taunts, which typically persecuted every creative product of my research and my mind. As usual, too, my countrymen will probably excel in spitting and scoffing. However, to these few people who still maintain an "open mind", and are still capable of rational thinking, I suggest to look beyond the usual ridicule and criticism of typical "down-to-earthlings" and "worshippers of No 5 wire", and rather pay their attention to what good, NOT bad, may arise from this my "invention".

After all, if we look beyond controversy imprinted e.g. in the way my "inventing" was done, the principle of operation, utilised phenomena, ancient origins, relationships with religions, etc., of "artefacts" and devices described here, then the most important in them turns out to be their inspiring role for the development of future science and engineering. After all, the idea of a "telepathic telephone", which these devices model and inspire, runs far into the future and tens of years probably must pass before the official human science will be able to properly comprehend it. After all, this device from the Polish city of Gdańsk is a blueprint, a model, or a copy (replica) of the communication device that uses telepathic waves to allow for a remote voice conversation. In this conversation, two (or more) such devices, identical to each other but located at significant distances from each other, turn human speech into modulated telepathic waves, which waves are then sent to another similar device, where they are converted

back into human speech. Thus, the operation of a prototype of such a device will be very similar to the work of so-called. "telepathic pyramid" described in more detail in my [treatise \[7/2\]](#) and in [treatise \[7\]](#), as well as in items #E1 to #E3.2 from the web page named [telepathy.htm](#). Only that this "telepathic pyramid" is designed for a direct and silent exchange of thoughts, while the device from Polish Gdańsk shown here is designed for a verbal conversation, in which telepathic waves are the carrier of the human speech. Hence this device from Polish Gdańsk is a model of the telepathic equivalent for today's "**mobile phones**". Only that from these mobile phones it is much more safe, healthy, perfect, and advanced scientifically. Also, similarly as today's "mobile phones", after the construction of the first working prototypes of such "telepathic phones" is accomplished (the work of which is highly beneficial for the health and is deprived of all detrimental influences), they will then be miniaturized, so that after several years they can even be surgically implanted into human bodies (so that they will always remain handy and ready for use).

Part #E: The "telepathic pyramid" as a today's version of the ancient use of communicative functions of the Great Pyramid of Cheops in Egypt:

#E1. What is this "telepathic pyramid"?

The "telepathic pyramid" is an electronic device which allows for a direct and silent exchange of thoughts by transmitting these thoughts in a beam of telepathic waves without the use of a human speech. The operation of this pyramid boils down to a capture of subtle vibrations of "biofield" that surrounds the hands of the person holding this pyramid (see "Fig. #E1" below), and which vibrations of the "biofield" faithfully reflect the thoughts of a given person. (This electromagnetic "biofield" is the one which envelopes the human form in so-called "aura" - photographs of which are shown on "Fig. #E1ab" and "Fig. #E2ab" from the web page named [soul proof.htm](#), and also the one the existence of which reveals the so-called "Kirlian photography"). After the capture of these vibrations of the "biofield" that reflects the thoughts of a person which generates it, the "telepathic pyramid" turns them into telepathic waves using a quartz crystal. These telepathic waves in turn are sent into space and then intercepted by a second identical, receiving "telepathic pyramid", that works on the same frequency of telepathic waves. In that second receiving pyramid, these waves are converted back into vibrations of the "biofield" - which biofield induces in the mind of the person holding this pyramid the thoughts that are exact repetitions of the thoughts sender. In this way, two (or more) persons holding in their his hands

such "telepathic pyramids" are able to mentally "converse with each other" at a distance and without the use of human speech.

The attribute of human thoughts, which decisively differentiates thinking from the human speech, is that in that thinking all God's creatures of the universe use always the same "language" which in subsection I5.4.2 from volume 5 of my newest [monograph \[1/5\]](#) is called the "ULT" - i.e. "Universal Language of Thoughts". So with this "ULT" are thinking NOT only people from every country and every race, but also all animals and all vegetation, UFOonauts, ghosts, and (of course) God Himself. Therefore, after building the "telepathic pyramid" described here, with the aid of it people will be able NOT only to converse between themselves beyond any language barriers or medical limitations, but also communicate e.g. with UFOonauts, or even with animals and vegetation.

An unusual feature of this "telepathic pyramid" is, that it generates itself the electricity required to its work. Therefore, after being constructed, it can also serve the humanity as a so-called "free energy device" described, amongst others, in items #C2 to #C2.1 and illustrated in "Fig. #C1" to Fig. #C4 "from the web page named [free energy.htm](#).

Quite an unusual feature of the "telepathic pyramid" is that myself, on the basis of my knowledge of "telepathy" which I have, only explained how this pyramid works, and published the descriptions of it on numerous totaliztic publications. However, **this pyramid itself was "a gift to humanity" donated by the unusual "being from stars"** - about which I suspect that it was one of those "simulations" which are described in more detail in items #L1 to #L5 from the web page named [magnocraft.htm](#). The person selected to receive this pyramid on behalf of the entire humanity, was the Italian "beauty miss" and the film actress named Daniela Giordano. In my opinion she fulfilled the task received in the best way in the world. I means, there is NO other person in the entire world, who would be able to promote the idea of "telepathic pyramid" and to inspire other people to get interested in this pyramid, than Daniela Giordano did it - which fact means practically that Whomever passed this "gift" to us, knows perfectly-well all people, personal attributes of each person, and knows all mutual links between people. This "giving to humanity" of the pyramid was also NOT the first time in the human history. As I am emphasizing this in item #E3 below, the Great Pyramid of Cheops from Egypt, also acted exactly as the "telepathic pyramid" described here - only that the Great Pyramid of Cheops allowed for a telepathic communication at interstellar distances.

The design and extraordinary work of the "telepathic pyramid" are described in detail in a whole range of totaliztic publications. For example, they are briefly described in items #E1 to #E3.2 from the web page named [telepathy.htm](#). This pyramid is also mentioned in items #C2 to #C2.1 from the web pages named [free energy.htm](#). However, the most detailed descriptions of it are provided in two treatises devoted exclusively to this pyramid, namely in the most recent [treatise \[7/2\]](#) and also in a slightly older [treatise \[7\]](#). The design and operation of the "telepathic pyramid" are also thoroughly explained in subsections K2 to K2.7 from volume 9 of my newest [monograph \[1/5\]](#).

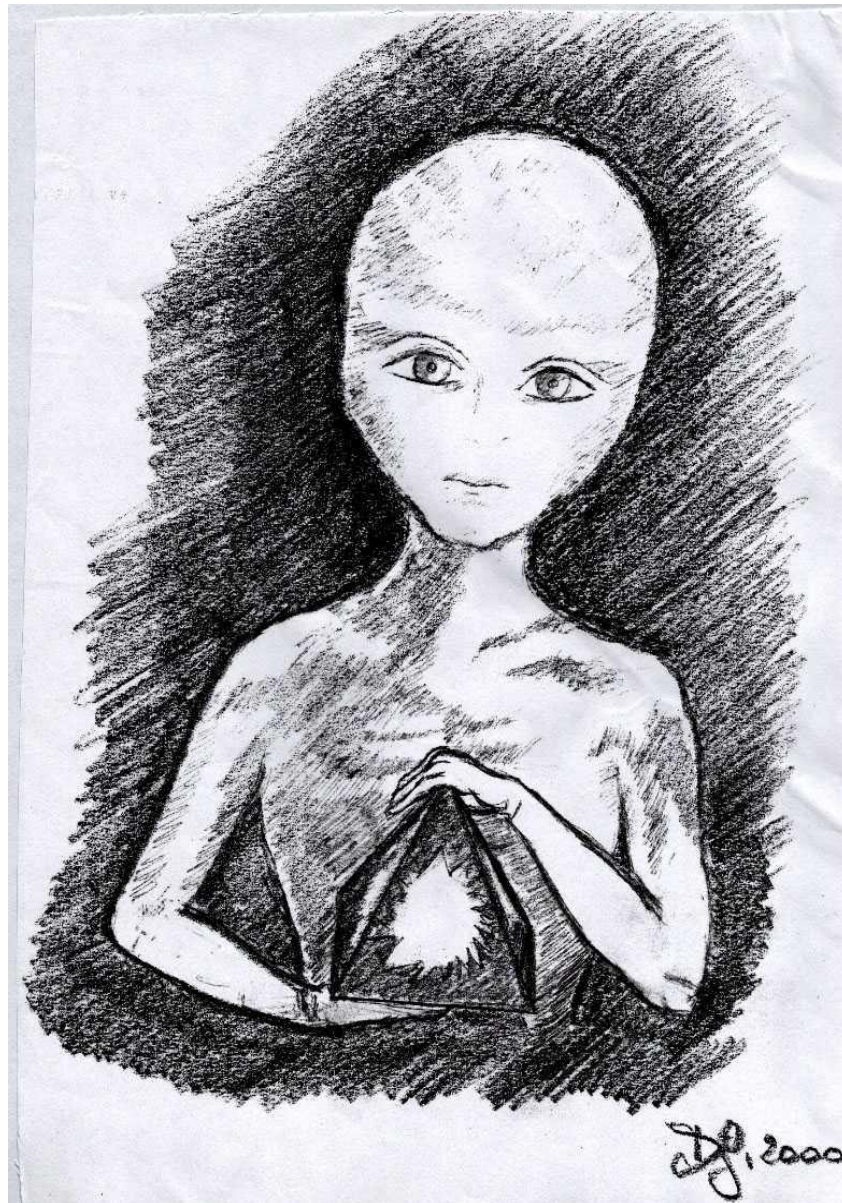

Fig. #E1 (J3 from [1/5]): A highly documentary drawing prepared personally by Daniela Giordano in 2000 - that is, prepared by the addressee of a "gift to humanity" in the form of a "telepathic pyramid" described here. (Daniela Giordano is also the co-author of the [treatise \[7/2\]](#) and [treatise \[7\]](#), which both describe the "telepathic pyramid".) The above Figure shows the "simulation" of the totaliztic "being from stars", which through the so-called "telepathic projector" demonstrates to Daniela Giordano the "telepathic pyramid" discussed here - descriptions of the design and operation of which this being gave the humanity as a kind of "gift". However, as this is supported by research refereed on this web page, this recent donation of the "telepathic pyramid" to the humanity was NOT the first such a gift. It turns out that the internal structure of the stone so-called "Pyramid of Cheops" from Egypt, in terms of functionality represents a version of the "telepathic pyramid" described here. This in turn means, that in fact this stone pyramid in Egypt in the distant past was performing exactly the same functions for telecommunication, as the described here the "telepathic pyramid". So in fact the "Great Pyramid of Cheops" from Egypt, in ancient times represented an already completed and working "prototype for the interstellar range" of the "telepathic pyramid" described here, hold above in hands by this "being from

stars" trying to help the humanity.

The above illustration originates from [treatise \[7/2\]](#), where it is presented as "Figure C1". It is also shown as "Figure J3" from volume 8 of my newest [monograph \[1/5\]](#). (In turn photos and drawings of the "telepathic pyramid" are shown in volume 9 of that monograph [1/5] - see "Figure K1" to "Figure K3" in there.) Of course, this Figure is also shown on several totaliztic web pages - for example, as "Fig . #3" from the web page [telepathy.htm](#), or as "Figure #1" from the page named [nirvana.htm](#). This illustration shows to us the appearance of a human-like "being from stars" supposedly originating from the cosmic civilization which practices a their version of "totalizm", and thus which tries to remotely help the humanity. It is this "being from stars" that gave to the humanity descriptions of the design and operation of the "telepathic pyramid" described here, as a kind of unusual "gift". Through the practicing of theirs version of [totalizm](#), members of that cosmic civilization remain in a state of perpetual "nirvana". On the face of this being one can even see the subtle emanation of happiness, which always radiates from the faces of those who experience such "nirvana" (for details on the subject of "nirvana" refer also to the information from the web page named [nirvana.htm](#)).

#E2. The design and principles of operation of the "telepathic pyramid":

The design and principles of operation of the "telepathic pyramid" has been described in detail in a whole range of totaliztic publications that are indicated in item #E1 above - e.g. in items #E1 to #E3.2 from the web page named [telepathy.htm](#), or in two treaties, i.e. in the most recent [treatise \[7/2\]](#), and in a slightly older [treatise \[7\]](#). Therefore, there is NO reason to repeat these descriptions here. The purpose for which I wrote this item is to just emphasize, that we already know exactly this design and principles of operation. Thus the only problem with this device is, that I myself do NOT have the required conditions (i.e. I do NOT have the required money, workshop space, tools, research instruments, etc.) to build this device myself, while **other researchers and hobbyists still believe these noisy "spitting", which my publications experience because of the action of so-called "curse of inventors", and therefore they do NOT want to join the effort of building the "telepathic pyramid"**. (What exactly is this "curse of inventors", the reader can read, for example, from item #G1 on the web page named [eco cars.htm](#).)

#E3. How the communicative work of the "telepathic pyramid" was implemented for interstellar distances in the Great Pyramid

of Cheops from Egypt:

As it turns out, analyzes of the structure and configuration of the ancient Great Pyramid of Cheops from Egypt lead to the conclusion, that in the distant past the pyramid was used just as an interstellar communication device which worked almost identically as the "telepathic pyramid" described here. Analyzes of mutual similarities between these two devices (i.e. the "telepathic pyramid" and the stone "Great Pyramid of Cheops" from Egypt) are described in Chapter E and in subsection C9 from [treatise \[7/2\]](#) (also available free of charge via this green link). So these analyses will not be repeated here.

Part #F: Advanced technical devices of antiquity operating on phenomena other than "telepathy":

#F1. God knew from the beginning of time which breakthrough technical devices the humanity is going to need in its development, therefore He made sure that already in ancient times the blueprint and model of each such a key device appeared on the Earth:

If onto examples of the ancient "miraculous technical devices" one looks at random, that is accordingly to this approach "a priori" used by the old official "atheistic orthodox science" and described in item #A3 from this web page, then the appearance on the Earth of each of these devices look like a coincidence. However, if one accepts "a posteriori" approach of the new "totaliztic science" and finally takes for sure of what I have proven in items #B1 to #B3 from the web page named [changelings.htm](#), then it turns out that the emergence of these devices on the Earth are a systematic work done by God. This work God continues to provide the humananity with models and inspiration for the construction of all of the key technical devices which this humanity will ever need for its development - as it is summarized in the "motto" to item #D1 from this web page. As a result of this systematic work of God, on the Earth even until the present time are available blueprints and models of virtually all of the key

technical devices that the humanity will need at any time. Of course, these devices are so numerous, that it is impossible to describe them all on this small web page. That's why I describe here only these devices which are either invented by myself, and about which only later I discovered that in past they already have existed on the Earth, or which I researched myself in connection with my altruistic search for the truth as an **"unpaid by any institution hobby-scientist"**.

#F2. The Biblical "Ark of the Covenant" - means the ancient version of the Oscillatory Chamber of my invention:

The name Oscillatory Chamber is assigned to a device of my own invention that produces various kinds of super-powerful magnetic fields - including the so-called **"telekinetic field"**. The magnetic field yield from this device is so powerful, that it can propel interstellar spaceships called the Magnocrafts, and even exert a control over time - thus providing us with the principle of operation for the future time vehicles (which time vehicles will give to people the ability to **live forever - means "immortality"**).

The magnetic field has also the ability to accumulate in itself huge amounts of energy. Thus, "Oscillatory Chambers" in the future will also serve to the humanity as a very capacious energy storing devices. In other words, they will serve also the humanity as devices for the invention of which the Senator McCain promised a reward of \$300 million - as this is described in item #D2 from the web page named eco cars.htm. However, although it is me who a long time ago invented this selected for the prize accumulator of energy of unlimited capacitance, while for many decades I fruitlessly tried to persuade Americans to allow me to build it for them, I am ready to bet anyone here that I will never see even a cent from these 300 millions of dollars - **this will not be the first public promise Americans are NOT going to keep under some convenient excuse** - for example, under the excuse that Senator McCain has NOT been elected the president (though he was voted for by millions of Americans on whose behalf he gave this promise, and although earlier or later, the descendants of these Americans will benefit from my invention of the "oscillatory chamber"). That promise of American Senator McCain made on behalf of Americans who voted for him, is NOT the only case in which I have fulfilled all the conditions for a reward being promised, but awards I have never seen the reward. For example, in 1990 the English magazine **"Sunday Mirror"** (Mirror Group Newspapers Ltd, Holborn Circus, London EC1P 1DQ, UK) has offered a reward of ten thousand pounds, to the person who is to explain what are and how are formed the famous English "crop circles". About this reward I learned from the article "Field of Dreams" (OMNI, Vol 13 No 3, December 1990, pp. 60-67,121-122,124,128) Soon afterwards I formally filled up my claim to this prize, providing the "Sunday Mirror" with a comprehensive explanation as to how, why, and because of what these

English "crop circles" are appearing on their fields. After all, by then in my numerous monographs I already have published a detailed explanation as to how these English "crop circles" are formed as "trails left by magnetic circuits of Magnocraft-type vehicles hovering at low heights". A present description of this explanation is still presented with almost no change, in subsections G11.3.2 (together with G3.1.6 and "Figure G13"), as well as in subsection V5.1 from volume 3 and 17 of my newest [monograph \[1/5\]](#). Unfortunately, in spite that no one has ever refuted or even challenged the validity of this my explanation, and in spite that with my formal proof described, amongst others, on the web page named [ufo proof.htm](#), I have proven scientifically that UFOs do exist physically and objectively, the editors of the "Sunday Mirror" simply refused to pay to me the reward that I deserved. Perhaps knowing my track record these editors also feared, that the received reward I may use for financing my research and for the development of my inventions, and that in this way the reward would only be used to a benefit of our civilization.

In several years after I invented the "Oscillatory Chamber", from various descriptions it come to me, that this chamber was already build and used in antiquity. This is because this device is described, amongst others, in the [Bible](#) under the name of the "Ark of Covenant".

An extensive description of the design, operation, attributes, and capabilities of the "Oscillatory Chamber" is contained in the dedicated to it, the entire volume 2 of my newest [monograph \[1/5\]](#). In turn the fact, that the prototype of the "Oscillatory Chamber" which was already built and already working in ancient times, was also the device called the "Ark of the Covenant" (this one described, among others, in the Bible), has been documented with overwhelming evidence in subsection S5 from volume 15 of my newest [monograph \[1/5\]](#).

#F3. "Vimana" from India - the ancient version of the [Magnocrafts](#) of my invention:

The Magnocrafts of my inventions God NOT only that demonstrates to the humanity at present times in the form of already built and flying [UFO vehicles](#) (as I explained this in item #L2 from the web page named [magnocraft.htm](#)), but also God makes them available to people already in the distant past in the form of already built and operating spacecraft. In ancient India, these spacecraft have been known and used under the name of "vimana". Descriptions of these 'vimana' can be found in sections A15.2, A15.3, P5.2 and V1 from volumes respectively 1, 14 and 17 of my newest [monograph \[1/5\]](#), and in section C4 and C7 from the [treatise \[7/2\]](#).

#F4. "Eternal lights" - i.e. originals for the

"votive lights" still used in Catholic churches, as ancient models for my "telekinetic lighting systems":

Such telekinetic lighting systems will operate in the future by stimulating in the illuminated room, or inside of the "eternal lamps" which illuminate a given room, of a special type of magnetic standing wave that can be called "a telekinetic wave". The course of field pulsations in such a standing wave must cause cyclicly-repetitive induction of telekinetic acceleration and deceleration of air molecules. In the case of the lighting "eternal lamps" type - these pulsations must cause the cyclical acceleration and deceleration of the particles transparent substances inside of such lamps. In the result, these molecules emit in turn a white so-called telekinetic "extraction glow" and a greenish so-called telekinetic "dispersion glow". In a case of triggering both of these effects inside chambers/devices filled with suitably selected gas or fluid, it is also possible to produce light other than shades of greenish - e.g. a red light. Because the telekinetic wave just by itself absorbs from the environment all the energy needed for its work, such telekinetic lighting systems will thus emit light without consuming any fuel and without the need to provide them with an external power supply. They will produce light which is emitted by the entire volume of air contained in the illuminated area, and thus which is not blinding for the eyes, does not cast shadows, provides an excellent visibility of every detail, and which can also be emitted in liquids and in transparent solids, rather than only in gases. An interesting fact of this is that the same lighting system, after it is supplied with a temperature sensor, can simultaneously function as the air conditioner, keeping the room temperature at a constant and in advance defined level.

For more information about these "eternal light" and about my "telekinetic lighting systems," see subsection H6.1.3 from volume 4 of my newest [monograph \[1/5\]](#).

#F5. The "amphora from Pakistan" - i.e. a type of the vibratory boiler that does NOT require fuel or energy supply:

This heater boiled water without consuming any fuel or energy. I described it accurately in item #E4.2 from the web page named [boiler.htm](#), and also in item #H3 from the web page named [newzealand visit.htm](#).

* * *

Notice that the above descriptions represent only the beginning of my research on the modelling and inspiring role of this mysterious "composite device" from the Polish city of Gdansk, and also the role of these other

ancient devices which discusses this web page. More on the results of my analyses and research of these extraordinary ancient devices will be explained here a bit later - that is, when my research reveals any new facts on their subject. So I suggest you have a look here again after some time. In the meantime, I would advise you to e.g. visit the Church of Mother Mary in Gdańsk, Poland, to see with your own eyes the device discussed here, and to compare its inspiring configuration to my description from this web page. I would also advise you to start having more careful looks at e.g. equipment from various old churches - for example at their so-called. "Confessions".

Part #G: Summary, and the final information of this web page:

#G1. Summary of this web page:

It appears that from time to time our planet is challenged, to instigate the faster development of humanity. I personally believe that the current revival of "fashion" on the "Zhang Heng seismograph" is not just a coincidence, but actually one of such challenges for humanity to rebuild this unique device and to open new horizons through finding out how it really works.

#G2. Emails and contact details to the author of this web page:

Current email addresses to the author of this web page, i.e. officially to Dr Eng. Jan Pajak while courteously to **Prof. Dr Eng. Jan Pajak**, at which readers can post possible comments, inquiries, or replies to questions which I ask on my web pages, are provided on the web page about me (Dr Eng. Jan Pajak). That page also provides other commonly used contact details to the author.

The author's right for the use of **courteous** title of "Professor" stems from the custom that "with professors is like with generals", namely **when someone is once a professor, than he or she courteously remains a professor forever**. In turn the author of this web page was a professor at 4 different universities, i.e. at 3 of them, from 1 September 1992 until 31 October 1998, as an "Associate Professor" from English-based educational system, while on one university as a (Full) "Professor" (since 1 March 2007 till 31 December 2007 - means at the last place of employment in his professional life).

However, please notice that because of my rather chronic lack of time, I

reluctantly reply to emails which contain **JUST** time consuming requests, while simultaneously they document a complete ignorance of their author in the topic area which I am researching. Therefore, if the reader sends a request to me, I suggest to let me know somehow that he or she actually went through the trouble of reading my web pages and learning what these pages try to say.

#G3. How with the web page named "skorowidz links.htm" one can find totaliztic descriptions of topics in which he is interested:

A whole array of topics equally interesting as these from the above web page, is also discussed from the angle that is unique to the philosophy of totalizm. All these related topics can be found and identified with the use of content index prepared especially to make easier finding these web pages and topics. The name "index" means a list of "key words" usually provided at the end of textbooks, which allows to find fast the description or the topic in which we are interested. My web pages also has such a content "index" - only that it is additionally supplied in green links which after "clicking" at them with a mouse immediately open the web page with the topic that interest the reader. This content "index" is provided on the web page named skorowidz links.htm. It can be called from the "organising" part of "Menu 1" of every totaliztic web page. I would recommend to look at it and to begin using it systematically - after all it brings closer hundreds of totaliztic topics which can be of interest to everyone.

#G4. A copy of this web page is also disseminated as a brochure from series [11] in the safe format "PDF":

This web page is also available in the form of a brochure marked [11], which is prepared in "PDF" ("Portable Document Format") - currently considered to be the most safe amongst all internet formats, as normally viruses cannot cling to PDF. This clear brochure is ready both, for printing, as well as for reading from a computer screen. It also has all its green links still active. Thus, if it is read from the computer screen connected to internet, then after clicking onto these green links, the linked web pages and illustrations will open. Unfortunately, because the volume of it is around a double of the volume of web page which this brochure publishes, the memory limitations on a significant number of free servers which I use, do NOT allow to offer it from them (so if it does NOT download from this

address, because it is NOT available on this server, then you should click onto any other address from [Menu 3](#), and then check whether in there it is available). In order to open this brochure (and/or download it to own computer), it suffices to either click on the following green link

[artefact.pdf](#)

or to open from any totaliztic web site the PDF file named as in the above green link.

If the reader wishes to check, whether some other totaliztic web page which he or she just is studying, is also available in the form of such PDF brochure, then should check whether it is listed amongst links from "part #B" of the web page named [text 11.htm](#). This is because links from there indicate all totaliztic web pages, which are already published as such brochures from series [11] in PDF format. I wish you a fruitful reading!

#G5. Copyrights © 2013 by Dr Jan Pajak:

Copyrights © 2013 by Dr Jan Pajak. All rights reserved. This web page is a report from outcomes of research of the author - only that is written in a popular language (so that it can be understood by readers with non-scientific orientation). Ideas presented on this web page (and also in other publications by the author) are unique for the author's research, and thus from the same angle these ideas were NOT presented by any other researcher. As such, this web page presents ideas which are the intellectual property of the author. Therefore, the content of this web page is the subject to the same laws of intellectual ownership as every other scientific publication. Especially the author reserves for himself the copyrights for the scientific discoveries and inventions described on this web page. Therefore, the author reserves that during repeating any idea presented on this web page (i.e. any theory, principle, deduction, interpretation, device, evidence, proof, etc.), the repeating person gives a full credit to the author of this web page, through clearly explaining that the author of a given idea is Dr Jan Pajak, through indicating the internet address of this web page under which this idea was published, and through mentioning the date of most recent update of this web page (i.e. the date indicated below).

Text of explanations from entire this web page, plus "Figure #B1", "Figure #C2" and "Figure #E1", represent excerpts from my [monograph \[1/4\]](#) entitled "Advanced Magnetic Devices". Therefore for them the copyright statement listed in monograph [1/4] applies. Also mine copyrights are extended onto "Figure #B2", "Figure #C3", and "Figure #D1". In turn copyrights for remaining "Figures #B3" to "Figure #B4" and "Figure #C1" belong to Mr [Tan Kee Wee \(email: keweetan@pacific.net.sg\)](#).

* * *

If you prefer to read in Polish click on the flag below
(Jeśli preferujesz czytanie w języku polskim
kliknij na poniższą flagę)



Date of starting this page: 24 December 2005
Date of the most recent update of this page: 17 February 2013
(Check in "Menu 3" whether there is even a more recent update!)

[counter](#)