

Proof Copy ([1/5] in the process of updating)

Prof. Dr Jan Pajak

Telekinetic devices

Scientific monograph no 10 from the series [1/5] on "Advanced Magnetic Devices",
5th edition, Wellington, New Zealand, 2007
ISBN 978-1-877458-90-3

Copyright © 2007 by Prof. Dr Eng. Jan Pajak.

All rights reserved. No part of this monograph may be reproduced, stored in a database or retrieval system, transmitted, or distributed in any form or by any means, electronic, mechanical, photocopying, recording, or otherwise, without the prior written permission from the author or a person legally authorized to act on his behalf. From the obligation of getting such a written permission are only released those who would like to prepare a single copy of this monograph for their personal use oriented towards the increase of their knowledge and who fulfil the condition that they will not use the copy prepared for any professional purpose or for accomplishing material gains, and also that they copy the entire monograph - including the title page, the content pages, all chapters, all illustrations, and all enclosures.

A private edition by the author. Registered in the National Library of New Zealand. Published in New Zealand in two language versions: English and Polish.

Date of the latest amendment of this volume and copy: 25 October 2010. (Note that in case of having access to several copies of this monograph, it is recommended to read the copy which has the latest date of amendment.)

This monograph is a scientific report from results of the author's research. For this reason all parts which have documentary or evidential value are presented accordingly to standards applicable for scientific publications (reports). Special attention is given to the requirement of repetitiveness, i.e. that on the basis of this monograph any professional scientist or hobby investigator who would like to verify, repeat, or extend the author's research should be able to recreate his work and arrive at very similar results and conclusions.

This monograph no 10 belongs to the series of the most important scientific publications by the author. It can be read either separately, or as a volume from the whole series. The entire series is marked [1/5] and have a general title "Advanced Magnetic Devices". It is already the fifth edition of this series. The previous (fourth) edition of it was the 18-volume scientific monograph [1/4] published in 2001 which carried the following title and editorial data: "Advanced Magnetic Devices". Monograph, Wellington, New Zealand, 2001, ISBN 0-9583727-5-6, a private edition by the author, 1800 pages (including 7 Tables and 163 illustrations, in 18 volumes).

All correspondence to the author of this monograph from the series [1/5] can be directed at the following his address in Korea before the end of 2007:

Prof. Dr Eng. Jan Pajak,
Ajou University, Suwon, South Korea

After the beginning of 2008 the correspondence should be directed at following author's permanent address in New Zealand:

P.O. Box 33250, Petone 5046, New Zealand
Home tel. (in 2010): +64 (4) 56-94-820; E-mails: janpajak@lycos.com or janpajak@gmail.com

ABSTRACT of this monograph no 10 from the series [1/5E] "Advanced magnetic devices", ISBN 978-1-877458-90-3.

This volume reviews the most significant theoretical research and experimental findings concerning magnetically propelled devices which utilise motion of counter-matter. The phenomenon utilized in the operation of these devices manifests itself through the action which is opposite to that of friction. As friction spontaneously consumes motion and produces heat, this new phenomenon spontaneously absorbs environmental heat and produces motion. Thus it seems to represent a reversal of friction. Because in its natural form this phenomenon is manifested during telekinetic motion, I have named it the "**Telekinetic Effect**". Research has shown that the Telekinetic Effect can be released in two different ways: (1) biologically through employing a natural capability of the human brain (such version of telekinesis induced by the human brain is frequently called "psychokinesis"), and (2) technologically, through an acceleration or deceleration of magnetic fields. When the Telekinetic Effect is released technologically, it allows for the building of magnetically propelled free energy devices (in this monograph called telekinetic power-stations) that spontaneously absorb environmental heat and produce useful motion. The use of these devices does not require any external energy supply. The monograph explains the design and principles of operation of all five basic categories of such telekinetic power-stations, i.e. motors, generators, aggregates, electrostatic machines, and batteries. Crude prototypes of all these devices are already operational.

In this volume the following main topics are addressed:

#1. An introduction of the Telekinetic Effect. This part refers to subsection H6.1 from volume 4 of this monograph, which explained that, except for friction, contemporary science has discovered a corresponding counter-phenomenon for almost every phenomenon. My discovery that there exists also an effect which represents a reversal of friction (i.e. the Telekinetic Effect) is discussed. Results of various experiments which confirm that the Telekinetic Effect in fact spontaneously absorbs environmental heat and produces motion are presented. The conclusion that the technological utilization of the Telekinetic Effect provides principles for the construction of free energy devices (telekinetic power-stations) is also stressed.

#2. Periodic Table postulating the future completion of telekinetic power-stations. My methodology that allows for the prediction of the future evolution of power producing devices is explained with two examples. This methodology utilizes the so-called "Periodic Tables" which are similar to the "Mendeléeev's Periodic Table of the Elements" except that they are designed for technological devices instead of elements. Such a Table, which is prepared for power producing devices, shows that the power-stations utilizing the Telekinetic Effect will constitute the next generation of these devices built on Earth. The Table also points out the phenomena and principles of operation utilized in these power-stations of the future.

#3. The technological activation of the Telekinetic Effect. Principles of telekinetic motion are explained on the basis of a theory called the "Concept of Dipolar Gravity". Biological and technological methods of producing telekinetic motion are described. The action of the Telekinetic Effect produced technologically through the acceleration or deceleration of magnetic fields is described.

#4. Review of the main categories of telekinetic power-stations already in operation. The major features of operational prototypes that represent all main categories of these devices are reviewed. Literature sources and research contacts are provided.

#5. The utilization of the Telekinetic Effect for transportation purposes. The gradual evolution of a spaceship called the "Magnocraft" into a vehicle propelled by the Telekinetic Effect is discussed.

This volume (together with volume 4) is especially recommended to all researchers who experiment on free energy devices, and on advanced propelling devices.

CONTENT

of the monograph no 10 in [1/5_E] "Advanced magnetic devices", ISBN 978-1-877458-90-3

| <u>Page</u> | <u>Chapter</u> |
|-------------|--|
| 1 | Title page |
| 2 | Abstract of monograph no 10 |
| 3 | Content of monograph no 10 (notice that content of the entire series of monographs [1/5 _E] is listed in volume 1) |

Monograph 10: Telekinetic devices (ISBN 978-1-877458-90-3)

| | |
|----------|--|
| LA-1 | LA. TELEKINETIC POWER-STATIONS (or "free energy devices") |
| LA-2 | LA1. Periodic Table postulating the future completion of telekinetic power-stations |
| LA-3 | LA2. Review of the main types of telekinetic power-stations built so far |
| LA-3 | LA2.1. Johnston Permanent motor |
| LA-5 | LA2.2. N-Machine |
| LA-7 | LA2.3. Telekinetic free energy generators |
| LA-9 | LA2.3.1. History of the telekinetic influenzmaschine |
| LA-12 | LA2.3.2. Excuses of Methernitha for withdrawal of dissemination of influenzmaschinen |
| LA-17 | LA2.3.3. Design, main circuitry, and operation of the telekinetic influenzmaschine |
| LA-24 | LA2.3.4. How to arrange own experiments on constructing the telekinetic influenzmaschine |
| LA-26 | LA2.4. Telekinetic batteries |
| LA-27 | LA2.4.1. Design and operation of telekinetic batteries |
| LA-35 | LA2.4.2. Recommended procedure for constructing a telekinetic battery |
| LA-40 | LA2.4.3. History of invention of the telekinetic batteries |
| LA-42 | LA3. Telekinetic devices for the conversion of biological, chemical, and thermal energy |
| LA-42 | LA3.1. Telekinetic healing and production of medicines |
| LA-43 | LA3.2. Telekinetic dissociation of water |
| LA-44 | LA3.3. Telekinetic heating and evaporation of liquids |
| LA-48 | LA4. Reaction of orthodox scientists - means difficulties of crushing a wall with our own head |
| LA-49 | LA5. Summary of utilisation of the Telekinetic Effect for energy production |
| LA-52/63 | Table LA1 and 11 Figures (LA0 to LA10) |
| LB-64 | LB. UTILISATION OF WHIRLS OF COUNTER-MATTER |
| LB-64 | LB1. Directing of winds on Earth |
| LB-66 | LB2. Technological formation of clouds and fogs |
| LC-68 | LC. MAGNOCRAFT OF THE SECOND GENERATION (telekinetic vehicle) |
| LC-68 | LC1. Principles of operation, and devices which allow the implementation, for magnetic propulsion systems of the future (reminder) |
| LC-69 | LC1.1. The Cyclic Principle which foretells the construction of three generations of magnetic propulsion systems |
| LC-70 | LC1.2. The Oscillatory Chamber – means a futuristic magnetic propelling device |

| | |
|-------|---|
| LC-71 | LC1.3. Magnocraft of the first generation and modifications of it |
| LC-72 | LC1.4. Magnocrafts second and third generations and their operational capabilities |
| LC-73 | LC1.5. Significance of the Concept of Dipolar Gravity as a theory which explains the operation and capabilities of Magnocrafts of the second and third generations |
| LC-75 | LC2. Operation and attributes of the Magnocraft of the second generation called also "telekinetic vehicles" |
| LC-77 | LC3. The state of telekinetic flickering and the consequences of it |
| LC-81 | LC4. Landings of the telekinetic Magnocraft of the second generation |
| LC-82 | LC5. Modifications of Magnocraft of the second generation |
| LC-82 | LC5.1. Telekinetic four-propulsor vehicle |
| LC-83 | LC5.2. Telekinetic personal propulsion |
| LC-83 | LC5.3. Telekinetic tractor beam |
| LC-85 | Figure LC1 (Three generations of four-propulsor vehicles) |

Notes:

(1) This monograph is a subsequent publication in a whole series of 18 scientific monographs by the author. Each chapter and subsection of this series is marked with a next letter of alphabet. Chapters and subsections marked with letters other than these provided in the list of content above are positioned in different monographs (volumes) of this series. The full list of content for all 18 monographs (volumes) of this series is provided in the first monograph (volume 1).

(2) A Polish language version of this series of monographs [1/5] is also available. Therefore, in case there is any difficulty with accessing an English version of this monograph, while the reader knows the Polish language, then it could be beneficial for him or her to read the Polish version of this monograph.

(3) Both language versions in this series of monographs [1/5], namely English and Polish, use the same illustrations. Only captions under these illustrations use a different language. Therefore, if illustrations for the English version are difficult to access or unreadable, then illustrations for the Polish version can be used equally well. It is also worth to know, that enlarged copies of all the illustrations for these monographs [1/5] are made available in the Internet. So in order to e.g. examine enlarged copies of these illustrations, it is worth to view them directly from the Internet. To find them, the reader needs to find any totaliztic web page which I authorise, e.g. by typing the key word "**totalizm**" to any search engine (e.g. to www.google.com), and then, after running a totaliztic web page, the reader needs to run from it the web page named "text_1_5.htm" available on the same server, or choose the option [1/5] from the menu of that totaliztic web page. Note that all totaliztic web pages allow also the uploading of free copies of this entire series of monographs [1/5].

(4) If the reader would find easier to read this monograph from a hard copy (printout) than reading it from a computer screen, it is worth to know that the PDF format in which this volume is prepared is "ready to print". In case of reading it from a computer screen, a simultaneous opening of two copies of this volume could be helpful, as it allows to open the first copy on the text while the second copy on the Figures, then allows to just jump from one window to another one when changing from reading text to looking at illustrations, or vice versa.

(5) The update and reediting of this fifth edition of [1/5] is going to progress gradually. But readers can realize from the content pages which chapters and subsections are already reedited, or are just subjected to reediting, because on the title page these are marked with the comment "**Proof Copy** ([1/5_E] in the process of updating)". The remaining chapters and

subsections of this monograph still should be digested in the formulation that was made for the previous, fourth edition [1/4] of this monograph.

(6) Note that the spelling used in this series of monographs is a mixture of US and UK English. The reason is that subsequent updates of this monograph were carried out at several different countries, some of which officially used US English, some other - UK English.

(7) To improve the structure of this series of monographs [1/5], the order of chapters and subsections from various volumes was slightly changed in relation to this order that appeared in the older monograph [1/4].

TELEKINETIC POWER-STATIONS (or "free energy devices")

Motto of this chapter: "The Universe is so designed, that accomplishing every goal is possible in it - we only need to find how to achieve this goal" (see subsections JB7.3 and I5.4).

The rocketing prices for fuels and energy, diminishing natural resources, pollution of the environment, holes in the ozone layer, glass-house effect, and a few other reasons motivate pioneer research on unique magnetic devices popularly called "**free energy devices**" to be advanced in a number of countries by devoted inventors. Because the operation of these devices employs mainly the unique phenomena which in subsection H6.1 is called the "Telekinetic Effect", they will also be called "**telekinetic power-stations**" in this monograph. The general purpose of these devices is to employ the reversal of friction capability of the Telekinetic Effect to extract thermal energy contained in the environment, and to convert this energy into a useful form (most frequently into electricity). Thus the operation of these new devices is drastically different from that of present sources of power. As is already known, present power supply devices utilize the difference (gradient) between two energy levels. Through causing a flow of energy from a higher to a lower level, they re-direct a part of this flow, and subsequently force it to convert into a useful form (e.g. into electricity). But the operation of free energy devices does not require differences in energy levels. They simply employ the reversal of friction to spontaneously absorb thermal energy which is always present in the environment, and then just transform this energy into a consumable form (e.g. into electricity). Therefore the use of these new devices does not depend on the availability of any external fuel or energy supply, such as combustible substances, wind, water flow, muscle power, electricity, etc. In this way the final outcome of free energy devices is very close to that implied by the ancient idea of "**perpetuum mobile**" called also "perpetual motion devices", although the mechanism and philosophy behind the achieving of this outcome is entirely different. (I.e. free energy devices do not create energy as this was assumed for "perpetuum mobile", but they simply "tap" to vast amounts of thermal energy always present around them and absorb this thermal energy by operating as a kind of self-sustainable heat pumps.)

The discovery that the Telekinetic Effect represents a reversal of friction, and subsequent discovery of the technological ways of activating this effect, provide the theoretical foundation for the building of telekinetic free energy devices. According to this newly gained knowledge about such devices, the extraction of energy from the environment requires only: (1) the building of devices that technologically release the reversal of friction capability of the Telekinetic Effect, (2) the absorbing of thermal energy from the environment and than its transformation into a useful motion, and (3) such channelling of the motion which is produced that it is finally converted into electricity.

According to common opinion of orthodox scientists, the operation of such free energy devices should not be possible, because according to these scientists they would appear to run against the Conservation of Energy Principle. Fortunately their devoted inventors have disagreed with standard beliefs and continued their research. After the first prototypes of these devices were built and proved themselves in action, common opinion again proved to be wrong - like so often before. It turned out that the completion of free energy devices is possible, and their operation doesn't contradict the Conservation of Energy Principle. The detail overlooked by those who disagreed was that these devices do not "create" energy - they only

spontaneously extract heat from the environment. Therefore, they produce electricity during their operation, but at the same time they also decrease the environmental temperature.

To illustrate the current state of these free energy devices, it is worth mentioning that a generator called "N-Machine" already exists (described in the later part of this monograph) whose overall efficiency is proven by strict empirical measurements to reach 104.5%. Of course the prototype of this generator, which has been investigated thoroughly, is still rather crude, and its numerous technical details can be subjected to further modifications. The 104.5% efficiency means that after re-directing back to this generator the amount of energy (100%) necessary to sustain its motion, 4.5% of its output still remains. This 4.5% constitutes "free energy" that the generator supplies to its user. The other device, presently operational in Switzerland, called the telekinetic INFLUENZMASCHINE, according to reports of the developers and several outside investigators, produces up to 3 kW of AC electric power (at 700-900 Volts) without any external fuel or energy supply.

The main goal of this chapter is to formulate scientific foundations for the systematic research and development of such devices which would allow for the construction of a working prototype of the currently most effective model of telekinetic free energy devices (i.e. the Swiss influenzmaschine). The auxiliary goal is to provide a basic textbook for people who currently conduct their own research on these extraordinary devices. To achieve these goals, the monograph in subsection H6.1 provides my theory explaining the phenomena and mechanisms behind the operation of these devices, while in this chapter it reviews the results of the most significant theoretical research and experimental findings concerning free energy devices, provides literature sources and contacts with other researchers in this field, and most of all supplies the technical documentation and detailed descriptions of a telekinetic influenzmaschine which is the first highly effective free energy device build on Earth, and already operational.

LA1. Periodic Table postulating the future completion of telekinetic power-stations

To illustrate the application of the Telekinetic Effect for the future evolution of **energy production** devices, I constructed a corresponding Periodic Table which is shown as **Table LA1**. This Table includes only those power producing devices whose operation utilizes various forms of motion. The motion in these devices is a kind of "catalyst agent" which absorbs the external energy, transfers it through various stages of conversion, to finally pass to an output medium. Thus, Table LA1 does not include all devices that produce electricity by various static principles, e.g. through the implementation of chemical, photo, or radioactive phenomena. For each type of these static devices it is necessary to construct separate Periodic Tables.

The Periodic Table LA1 contains the names of all important power producing devices. These are listed at the cross points of the rows and columns. The placement of a particular device in a given row indicates the attributes of motion utilized in its operation, and thus also the generation (or the level of advancement) to which this device belongs. The placement of a device in a given column indicates the general category of devices to which it belongs, thus it also shows the technological implementation of its principles of operation. The empty boxes in this Table show the gaps which still exist in our inventions of these devices. The location of these empty spaces (i.e. their row and column) informs about principles of operation of those devices not yet invented.

The horizontal broken line inserted into this Table shows the level of technology in power producing devices achieved to date. This line separates the devices which our civilization has already completed (see all the devices listed below the line), or is able to complete, from all those devices whose operation still needs to be learnt through the discovery and investigation of new phenomena. The devices named below this line already exist, whereas those named above it will be completed in the future. It is worth noticing that there are empty boxes below the broken line. Such spaces indicate that the appropriate phenomena

which are required for the completion of these devices are already known, but the lack of demand for the application of such devices has caused their invention to be unnecessary or delayed for some unspecified time.

In the left section of the Periodic Table, inside the thick lines, details of the energy producing phenomena that are utilized by devices from a particular row (generation) are defined. This column is further sub-divided into three sub-columns which describe: (1) the energy carrier utilized by the devices listed in the rows on the right, (2) the generation number to which these devices belong (the higher this number, the more advanced the device), and (3) the attributes of motion, which are utilized for the operation of devices listed in the rows. As with the elapse of time all three items described above move into their higher levels, this column also represents the time axis of the Periodic Table.

Examination of the time axis from the Periodic Table shows that the power producing devices utilize three energy (motion) carriers: (1) mechanical motion, (2) flow of gases or fluids, and (3) motion of magnetic fields. For each of these energy carriers three subsequent generations of the power producing devices are built. Each of these generations utilizes a different set of attributes of a motion. The first generation utilizes only a steady motion or a flow. The second generation utilizes a motion of the energy carrier as well as its acceleration or deceleration. Whereas the third generation utilizes a motion, an acceleration, and an internal energy reserve (e.g. compression, heat, etc.).

In the row within thick lines at the bottom of the Periodic Table, the categories of the devices listed in each column are named. These describe the technological implementation of the principles of operation utilized by devices from each column, including the main output of their work. Because of this operation, five separate categories of power producing devices can be distinguished. In this monograph they are called: (1) motors, (2) generators, (3) aggregates, (4) electrostatic machines, and (5) cells or batteries. All of them together carry also a more general name "power stations".

Amongst numerous types of power stations so-far developed by our civilization, the direct connection with the topic of this chapter have devices called "telekinetic free energy devices". Let us now learn more about these unusual power-stations. The most representative of these will be briefly described in the subsection to follow.

LA2. Review of the main types of telekinetic power-stations built so far

A number of prototypes of telekinetic power-stations have already been completed by dedicated inventors who arrived at their construction empirically. But so far there has been no theory which would explain the operation of these extraordinary devices. This has made their improvement and manufacture even more difficult, and it has also impeded formal recognition of these devices by the scientific establishment. Only after the formulation of the Concept of Dipolar Gravity and the discovery that the Telekinetic Effect operates as the reversal of friction, was such a theory created. Its existence allows for the rational explanation of the principles of telekinetic free energy devices, and formulates a theoretical foundation that allows for the systematic improvement of these devices.

During the analysis of subsequent telekinetic free energy devices it is worth noticing that although these devices are designed to produce electrical energy, their structure and operation are typical for mechanical (not electrical) machinery. Such an apparent contradiction results from the fact that at our level of knowledge, the release of the Telekinetic Effect requires the motion and dynamic interactions of parts in a complex mechanism - i.e. the phenomena studied by mechanical engineers.

LA2.1. Johnston Permanent motor

A very simple telekinetic free-energy device already completed on Earth, is a motor which contained only permanent magnets, and thus which is called "Permanent magnet motor" or "PMM". This motor was invented by Howard Johnson (address in 1989: P.O. Box 199, Blacksburg, Virginia 24060, USA). Historically, it is considered to be the first operational telekinetic motor ever completed on our planet. Its design and operation are published in article [1LA2.1] by Jorma Hyypia, "Amazing Magnet-Powered Motor", Science & Mechanics, Spring 1980, pages 45-48 and 114-117. This motor is subject to USA patent no 4,151,431. According to reports, its efficiency slightly exceeds 100%. Thus, once started, it sustains its operation until intentionally held back or until its mechanical parts wear out. But the excess of its output power is still too small to be useful. Therefore, its significance lies in proving that the construction of telekinetic devices capable of self-sustaining their own motion is feasible, whereas the energy produced by this motor hasn't any practical application.

Out of all free energy devices, telekinetic PMM motors similar to that of the Johnson device, are the subject of inventive activities of the highest intensity. The development of various versions of such motors has been carried out by numerous inventors in a number of countries. But all these devices are still in the research and development stage. In 1990s a lot of publicity was received by a telekinetic motor invented by Ulrich Schumacher. (Address in 1991: Ulrich Schumacher KG, Sperbersloher Strasse 564, D-8509 Wendelstein, West Germany).

The general design of the Johnson motor is shown in part (a) of **Figure LA1**. The original design of this motor contains only two relatively moving parts - marked as (1) and (3) in Figure LA1. (The introduction of the third part, marked as (2), is proposed by me to explain ways of increasing the efficiency of such motors.) The stator (3) contains a set of small magnets located in equal distances from one another. Above the stator (3) magnets of the Telekinetic Effect activator (1) move in the direction "V". The shape of magnets (1) is vital, i.e. they must be a half-moon or banana shape. The proportion of dimensions of both groups of magnets, i.e. (1) and (3), is also vital.

The operation of the Johnson motor, explained by three subsequent stages of release of the Telekinetic Effect, is also illustrated in Figure LA1. Parts (a), (b), and (c) of this Figure show three successive positions that the activator (1) takes in relation to the stator (3). The thick closed line passing through magnets (1) and (3) represents the path of the magnetic circuits (force lines) that join both of these parts. The operation of this motor begins with stage (a) in which magnetic circuits are in an equilibrium position. But the inertial motion of the activator (1) in the direction "V" causes these circuits to jump into the position shown in part (b) of this Figure. During such a jump, the magnetic circuits are accelerated. This acceleration releases the telekinetic elementary drive "P". A small fraction of this drive acts also at both ends of the magnet (1), providing them with an impulse that sustains the motion "V". The special shape of the magnet (1) causes it to intercept part of the telekinetic drive released by the motion of this magnet. The jump and acceleration of magnetic circuits extend until stage (c). Further motion of the activator (1) in the direction "V" causes the final return to the equilibrium position already described in part (a). Then the whole cycle of the operation is repeated.

After an analysis of the Johnson motor it becomes obvious that the greatest value of the elementary telekinetic drive P' is released just above the magnets of the stator (3), where the acceleration of magnetic circuits is the largest. This indicates that the efficient telekinetic motors should contain not less than three relatively moving parts, i.e. a stator (3), a Telekinetic Effect activator (1) and a rotor (2). In such a three-part motor the mutual interactions between the stator and the field activator are only to release the Telekinetic Effect. But the impulse of elementary drive P' of this effect is intercepted by the rotor, which then feeds a part of the impulse just received back onto the activator - to sustain its motion.

This shows why the main drawback of the Johnson motor is its low efficiency. It results from the use of only two relatively moving parts instead of three. The activator (1), that normally should release only the Telekinetic Effect, in this motor also tries to intercept its

driving impulse. Of course, because of its inconvenient location, it intercepts only a small fraction of the telekinetic drive that it releases. Moreover, the part of the drive intercepted during the acceleration of magnetic circuits is then eliminated by an opposite drive intercepted during the deceleration of the same circuits. This drawback can easily be eliminated through the introduction of a segmented rotor (2), placed between the activator (1) and the stator (3) - as is marked in Figure LA1 by a broken line. The rotor (2) would spin at a speed at least two times greater than that of the activator (1), and would be joined with mechanical gears. During the operation its blades would always appear in the place of the strongest telekinetic drive P', and disappear from the area of the opposite action of the Telekinetic Effect. The use of a rotor for the interception of the telekinetic drive would also simplify the design of this motor. This is because the activator (1) would not then require magnets of a special shape. It is worth mentioning here that the spinning of the rotor (2), could also be used for the generation of electric power in a manner similar to that used in the N-Machine. Thus the appropriate design of this rotor could transform the telekinetic motor into a telekinetic aggregate.

While discussing the Johnson motor it is worth noting that its inventor was unaware of the existence of the Telekinetic Effect. Therefore he explains the operation of this device in a different manner. According to his explanation, the continuous motion of this motor is the result of an imbalance between the magnetic attraction and repulsion taking place in opposite directions. Of course this explanation does not say why his motor requires the initial starting impulse of the motion (for its operation caused by such an imbalance should be able to start on its own). Also such an explanation eliminates the justification for a third moving part, thereby giving no theoretical clues as to how to improve the efficiency of this device.

Although I do not know details, I am aware that all PMM motors were vigorously suppressed and persecuted by some sort of evil power. Thus Johnson motor never went into an industrial production, in spite that it achieved the technical state when it could be produced and sold as a curiosity and toy that illustrates the possibility of "perpetuum motion" (I would buy myself such a toy, if it is available on sale). Some hints about types of persecution that the inventor of the Johnson motor experienced are provided already in the article [1LA2.1] indicated above.

LA2.2. N-Machine

The first prototype which provided the scientific confirmation for the feasibility of telekinetic free energy devices, is a **generator** called the "N-Machine". A photograph of this generator is shown in **Figure LA2**. The N-Machine is the best known and the most thoroughly investigated telekinetic free energy device. The results of its operation, and also all of its technical details, are available to interested people without any secrets. Actually, the N-Machine so far is the only telekinetic device known to me, whose vital technical details are not kept confidential. The constructor of the N-Machine is the late Bruce DePalma, an investigator of free energy devices, presently recognized as the leader in the scientific approach to the extraction of energy from the environment. It is almost sure, that it was for the creation of N-Machine that the late DePalma paid with his own life, falling a victim of assassination organised for him by UFO-nauts – as this is described in subsection W4. But the principles of operation of the DePalma generator is based on the spinning magnetic disk invented in 1831 by Faraday – as this is described two paragraphs below. His first prototype of the N-Machine, the late DePalma conducted in the DePalma Energy Corporation. (Address in 1989: he DePalma Energy Corporation, 1187 Coast Village Road #1-163, Santa Barbara, CA 93108, USA). This prototype was later replicated and thoroughly researched in cooperation with the Indian Nuclear Power Board, Karwar, India. But difficulties and persecution that the late DePalma experienced in the USA during the construction and research of his first prototypes, caused that in 1990s he shifted initially to Australia, and then to New Zealand, in search of conditions in which he would not be persecuted. Unfortunately he did not escape

from vindictive UFO-nauts, who got him finally in New Zealand. In New Zealand DePalma died rapidly and prematurely on Thursday, 2 October 1997, in the middle of his creative potential and in very mysterious circumstances which suggest his possible assassination by UFO-nauts – as this is described in subsection W4. The last before his death developmental works on N-Machine he carried out in the DePalma Institute, 211 Howard Rd, Private Bag 11, Oerere Point (i.e. suburb of Auckland), New Zealand.

Soon after the completion of one of the first prototypes of the N-Machine, a group of experts several times measured precisely the overall efficiency of the DePalma generator. This first crude prototype, in the most unfavourable conditions, had an efficiency amounting to 104.5% of the total energy input to the electric motor that supplies rotational speed "n" to the generator - see **[1LA2.2]** "Report on the Initial Testing Phase of N-1 Electrical Power Generator", DePalma Energy Corporation Report #1, 6 January 1988, page 6. The results obtained by DePalma encouraged other investigators to repeat his findings. All three investigators who made their results available (Trombly, Tewari, Kincheloe) confirmed the achievement of a similar level of the generator's overall efficiency [1LA2.2].

Detailed descriptions of this generator are contained in several reports. In past these reports were prepared and disseminated by the DePalma Corporation (e.g. [1LA2.2]). Video tapes that demonstrate its operation could also be purchased on request in past. Furthermore, when DePalma was alive, his prototypes could be examined and measured in the laboratory of the DePalma Corporation. (Note that the mysterious circumstances of the DePalma's death are described in subsection W4.) The prototype of the N-Machine, which has been investigated in most details, has about 1 meter in length and 0.4 metres in diameter. Its weight is around 400 kilograms. Its output reaches 2480 Watts (i.e. 800 A x 3.1 V) of a direct current (DC), for the input rotations of about 2600 rev/min.

A diagram of the N-Machine is shown in **Figure LA3**. The most important part of this generator is a solid, bronze rotor (2) assembled on a rotary shaft (1), and consisting of permanent magnet segments (3). In the prototype shown in Figure LA2, a NdFeB permanent magnet is used, which has the shape of a ring 212 mm long and 330 mm in diameter. It produces a field of about 6750 gauss. The electrical energy produced in the rotor (2) is collected by brushes (4) and (5), which transfer it to an output collector (9). At the end of the shaft (1) a belt transmission (6) is located. The rotor (2) is supplied with the required rotational speed "n" via this transmission (6) and the shaft (1). The speed "n" is produced by the propelling motor (7). The electric current is passed to the motor (7) from an input collector (8).

The operation of the N-Machine is based on an old empirical discovery in 1831 by Michael Faraday. Faraday discovered that the spin of a conductive magnetic disc creates a difference of electric potentials between the peripheral and the centre of this disc. To utilise this difference of potentials in 1831 Faraday build the first electricity generator, the design and operation of which were almost identical to the design and operation of N-Machine. But the origin of this difference of potentials was satisfactorily explained only after the Telekinetic Effect was discovered, and after it was established that the centrifugal acceleration acting on magnetic field of the spinning Faraday disk, releases the Telekinetic Effect technically, while this effect moves telekinetically electrons contained in the spinning disk – for details see subsection H6.1. The late DePalma was satisfied with the very existence of this electromotive force, and he did not try to theoretically establish where this force comes from. Although I was in contact with DePalma and shared with him my theory of the Telekinetic Effect and explained to him how this effect releases the electromotive force in his machine, he himself for some strange reasons never accepted this theory, never recognised the existence of the Telekinetic Effect, and never approved that this effect performs a major role in his machine. In spite of this non-recognising of the Telekinetic Effect by DePalma himself, I am presenting below the operation of the N-Machine in the light of the action of this effect.

In the DePalma generator, a motor (7) produces the rotary motion "n", and supplies this through a belt transmission (6) and a shaft (1) to the rotor (2). The fast spinning of the bronze rotor (2) produces the centripetal acceleration that acts at the force lines of a magnetic field

yielded by the magnet (3). This acceleration releases the Telekinetic Effect whose drive P begins to act upon the free electrons contained in the bronze rotor (2). Subsequently, this P drive causes the dislocation of these electrons and the formation of a difference of electric potentials between the brushes (4) and (5). This difference amounts to about 1.216 V for each $n=1000$ rev/min. The brushes (4) and (5) are connected to the output collector (9) which passes on the current produced for use. After the short-circuiting of the outer connections, the present prototype of this generator produces power of about $W_0=800A \times 3.1V$.

DePalma's experiments determined that there is a critical density of the magnetic field which saturates the bronze rotor. Below this critical density, the increase of a magnetic flux supplied to the rotor increases proportionally the electrical output of the generator. But above this critical density, the increase of the field does not cause an increase in the output. It seems that such a saturation results from the number of free electrons which exist in a given volume of bronze, and which can be shifted by the Telekinetic Effect. This critical density can be easily achieved through the application of permanent magnets.

At the final level of development of the N-Machine, accomplished before the death of DePalma in New Zealand, some technical obstacles still exist which hold back its commercial use. These obstacles are caused mainly by problems with the effective utilization of the generator's output for a self-supply of its own energy consumption, i.e. the consumption of energy by the electric motor that provides the rotations necessary for its operation. The successful solving of these problems requires further experiments and research. The most difficult aspect of these problems is that the Telekinetic Effect is able to create only about 1.216 V for each $n=1000$ rev/min of the rotor. Thus the entire power of the N-Machine is contained in its Amperes, not in its Volts. On the other hand, designs of highly efficient electric motors require the input voltage of about 24 V. Therefore a commercially viable N-Machine needs to be able to produce at least this high voltage.

The DePalma team tried to resolve this problem through the use of two rotors on a common shaft, and their subsequent connection in a series. But after the building of such a prototype, it turned out that the magnetic field from one rotor interferes with the operation of the other, and vice versa. Moreover, the additional electric current which is forced to flow through a given rotor, but which originates from the other rotor, releases a number of electromagnetic effects of the first generation. These first generation effects (e.g. a right-hand rule, Lorentz force, Hall effect, etc.) increase the drag (friction) of the generator and neutralize the action of the Telekinetic Effect. It appears that the only way to resolve the low voltage problem in the N-Machine is to complete a pilot research on the Telekinetic Effect first, and only after this, to implement the findings obtained. The difficult part of this problem is how to release the Telekinetic Effect so that it is not accompanied by any other electromagnetic effects of the first generation. There is the possibility of such segmentation and serial connection of the rotor, so that the shape of subsequent segments exactly corresponds to the direction of telekinetic drive, whereas their capacity corresponds to the output of this Effect.

There are various rumours, that shortly before his death, DePalma actually found empirical solution to his voltage problem. However he died (was assassinated by UFO-nauts) before he managed to implement this solution. The secret of his solution died with him.

LA2.3. Telekinetic free energy generators

One of the reasons for the low commercial viability of current telekinetic devices is that they must cooperate with the devices of the first generation, while they themselves belong to the second generation. For example, the Johnson motor requires a generator of the first generation to convert its mechanical output into electricity. In turn the DePalma generator requires a motor of the first generation to feed it with the rotational motion. This draws us to the obvious conclusion that the overall efficiency of telekinetic power-stations can be increased in a simple way through the coupling together of two devices of the second

generation. In this way more than 100% efficiency of the telekinetic generator would add to a similar efficiency of the telekinetic motor, significantly increasing the excess of overall efficiency. Even better results would be achieved when the operation of both of these devices could be combined inside a single device. In this way a telekinetic **aggregate** would be achieved in which two separate Telekinetic Effects would produce simultaneously: (1) the motion required for the operation of this device, and (2) the electricity representing its output. In such an aggregate the energy loss from friction would be reduced to half of the losses from the separate motor-generator devices. Therefore its efficiency would also increase about two times.

I have heard about many developers that worked on the research and development of telekinetic aggregates. In 1970s a significant publicity attracted works of an Englishman named John R.R. SEARL (17 Stephen's Close, Mortimer, Berkshire, RG7-3TX, England). Unfortunately, in spite of intense searches I was unable to find even a single witness, who would in person and with own eyes see a working device of this developer.

A different situation is with the telekinetic free energy devices, the general name of which is telekinetic "**influenzmaschinen**". Several operational models of such devices already exist (for a long time) and work in Switzerland. The most known out of these models is called the "Thesta-Distatica". I am going to describe here details and descriptions of this model. However, I have the duty to mention, that these details originate from various sources, sometimes even having character of a "gossip". Not in all matters I was able to verify my data as scientifically correct. After all, the Methernitha keeps all technical details of their machines in quite a strict secrecy.

The telekinetic free energy device named **Thesta-Distatica** in appearance resembles slightly the Wimshurst electrostatic machine – see Figure LA4. The weight of the operational prototype shown in Figure LA4 is around 20 kg. Its two discs of the diameter around 55 cm rotate in two opposite directions with rotational speeds described as equal to $-n = n = 60$ rev/min (RPM). (But as it results from my own calculations, in order to generate AC current of $f=50$ Hz frequency, the precise value of this rotational speed should amount to $n = 62.6$ rev/min (RPM). For details see equation (1LA2.3.3), and my calculations that result from this equation, that are presented in subsection LA2.3.3. The reason is, that because of the practical constrains, the Methernitha provided the machine with $e = 48$ electrodes, instead of $e = 50$ electrodes that would be extremely difficult for the practical measuring and allocating around a circumference of a circular disk.) According to information disseminated by various sources about this free energy device, it generates a **direct current** (DC) having a fluctuating voltage with momentary values from the range of around 700 to 900 Volts and a power of up to 3 kW. (In order to supply typical electrical appliances via this free energy device, Methernitha later bits down this high voltage to the value of around 250 Volts, by using ordinary resistors.) The source of such a common opinion, that this free energy device produces a direct current, is the belief of majority of people that the Wimshurst machine, on which this free energy device is based, is able to produce only direct current (DC). However, I discovered in old descriptions of this machine (summarised below in this subsection), that the Wimshurst machine can be also so modified that it produces an alternating current (AC). I personally believe, that the operation of the Thesta-Distatica is based on just such a modification of the Wimshurst machine, designed for generating the alternating current (AC). Therefore, according to my own opinion, that is supported by the principles of operation of telekinetic **influenzmaschinen** that I invented and described in subsection LA2.3.3, the Thesta-Distatica free energy device generates the **alternating current** (AC) of the frequency around $f=50$ Hz. A by-product of the operation of this free energy device is the ionization of the surrounding air, the production of ozone, and also the cooling down of this air. Except for quick starting by hand, the continuous and unlimitedly long operation of this machine is self-sustained by its spontaneous absorption of heat from the environment by the telekinetic effect that it releases. Thus similarly like hypothetical "perpetual motion" devices, it does not require any external supply in fuel nor energy. So the entire electrical output of this device

represents a useful energy obtained literally "for free". Therefore the telekinetic influenzmaschine is the world's first free energy device which at the present stage of its development is ready for limited commercial applications. Although I myself have not seen with my own eyes this free energy device in operation, so-far I managed to find, check, meet, and interview, around 10 people who saw in person the Thesta-Distatica in operation. For me there is no even a slightest doubt, that the existence and operation of this free energy device is undeniable fact. Only that, for reasons that become obvious after reading subsection A3 of this monograph, this device is reserved for the own use of Methernitha and it is not open for a public insight nor dissemination.

Let us now explain briefly the origin of the idea of telekinetic free energy device. The name "influenzmaschine" was formed by combining together two current German terms "influenz" and "maschine", which mean the "electrostatic induction" and "machine". However, originally this name comes from the English term "influence machine" that initially was assigned to appropriate class of electrostatic machines by their first English inventors. These inventors used term "influence" for describing the phenomenon of "electrostatic induction" utilized in the operation of their machines, which represented an alternative to the phenomenon of friction also utilized in a different types of electrostatic machines by other inventors (e.g. in the Volta's electrophorus or Van de Graaff device).

The construction of the first telekinetic influenzmaschine is not the achievement of a single person, but the outcome of an intensive thinking and research of numerous dedicated inventors. The forerunner of the present design of conventional electrostatic machines was a clumsy device patented in 1860 by the British inventor named C.F. Varley (Bryt. Spec. Pat. No 206 of 1860). However the first successful influenzmaschine was built by A.J.I. Töpler in 1865. His device used a single disk that co-operated with a couple of stationary electrodes, thus inducing electric current in return for the work of winding a winch. Parallely to Töpler, a number of very similar machines were constructed between 1864 and 1880 by W.T.B. Holtz. In 1880 a tool maker from Berlin named Robert Voss combined together the principles of Töpler and Holtz, obtaining a very effective electrostatic machine with a single spinning disk. It is worth mentioning here that the device which in current textbooks of physics is described under the name of the Töpler machine, in reality is the Voss machine. However, all the above influenzmaschinen were put into shadow by the invention of an Englishman named James Wimshurst. Around 1878 he increased the efficiency of the electrostatic induction by adding to his machine the second disk that rotated in a counter-direction. In the last years of 19th century Wimshurst machines frequently performed the function of current electricity generators, finding the application in numerous areas, e.g. as electricity suppliers for X-ray lamps. At that time were also constructed versions of the Wimshurst machine that generated alternating current (AC). In almost unchanged form very simple Wimshurst machines for the direct current (DC) are build until today for teaching purposes. One of the currently produced models of this machine is shown in Figure 11 of monograph [6/2]. However, as the electricity generators utilizing electromagnetic induction become popular, influenzmaschinen gradually got forgotten. Their descent lasted until the second half of this century.

But, as readers will realize from the content of this monograph, currently emerged the period of second youth of influenzmaschinen. This period was initiated around 1960, when the first "telekinetic influenzmaschine" was build, that introduced further functional modifications to old influenzmaschinen, by adding to their operation principles of electrostatic motor and the action of the Telekinetic Effect released within a telekinetic battery. The builder of this telekinetic influenzmaschine was an Austrian citizen named Adalbert Béla Brosan. The appearance of his telekinetic free energy device resembled an improved version of the Töpler electrostatic machine. More details on this subject is to be provided in next subsection. Brosan's machines initiated the era of appearance of telekinetic influenzmaschinen on Earth.

A common opinion prevails that every new device appearing on our planet is simultaneously and independently invented by a number of individuals who do not co-operate with each other, and thus who do not know details of the developments of others. This also seems to be the case with the telekinetic influenzmaschine. I am aware of the existence of three inventors of the telekinetic influenzmaschine, each one of whom either build this device independently of the others, or just independently worked out the operation and the design of it. These inventors are (chronologically): Adalbert Béla Brosan of Linz (Austria), Paul Baumann of Linden (Switzerland), and me - the author of this monograph (New Zealand).

I learned about the first inventor of the telekinetic influenzmaschine in 1991 by "pure coincidence". (According to totalizm described in chapters JA and JB, there is no such thing as "pure coincidence", and all events that affect us are purposely designed by the universal intellect, so that always is a clear goal for them to happen.) In 1991, means in the period of the most intense research on my theory of the Telekinetic Effect and on telekinetic power-stations, I met an Austrian couple named Tilgrid i Fred Pfeiffenberger (address in 1991: Armandale Rd. 7, Kinloch, R.D. Queenstown, New Zealand). They emigrated to New Zealand in search of an alternative (natural) lifestyle. The information and facts this couple provided could not be verified because of technical reasons. Therefore I only repeat it here in the form as it was reported to me. The couple, at some stage in their life, observed the fate of the invention of their acquaintance named Adalbert Béla Brosan (address in 1965: Schiffmeisterplatz 5, Ybbs/Donau near Linz, Austria). He got into the possession of the design for a wonder device of the "perpetuum mobile" type, which represented an improved model of the Töpler's electrostatic machine. When put by hands into the motion, his device kept rotating infinitively, while simultaneously it produced electricity. Brosan described his invention in the brochure **[1LA2.3.1]** "Weltfrieden durch Kostenlose Energie", published in 1965 by Karl Schenenberger Verlag (address in 1965: Stapfenstrasse 187, Helden, Switzerland). The couple Pfeiffenberger had in New Zealand a copy of this brochure and familiarised me with the content of it. Unfortunately, Adalbert Béla Brosan did not provide any diagram nor technological details of his machine in this brochure. Because Brosan was a theoretician, he had no technical skills nor tools or equipment required to build his device himself. Therefore, to complete a prototype of his invention, he formed a partnership with the local "golden-hand" named Nitschel that originated from the area of Linz. (It seems to be the vital detail, that Nitschel was known not only for his ability to make everything, but also from his radical religious convictions, for which he came to the notice of the local authorities.) With the assistance of Nitschel's technical skills and equipment, Brosan built two small prototypes of his device. Brosan managed to show the operation of his prototypes to a few friends and acquaintances, including the couple who reported the whole story to me. According to descriptions, both these prototypes were of an appearance and size identical to models of the "Testatica" currently owned by the Methernitha. Unfortunately, soon afterwards Brosan died. In turn Nitschel, together with both operational devices supposedly shifted to Switzerland to the Apenzell area (CH-9050), tel: (071) 914110. The further fate of Nitschel, as well as the Brosan's devices, has been impossible to establish for me. But it should be noticed, that two small devices called the "Testatica", which according to existing descriptions look identically to these constructed by Brosan, are currently in the possession of the Swiss religious community calling itself "Methernitha". This is the end of the story (as I heard it) about the first inventor and builder of the telekinetic influenzmaschine. The important unanswered question which it seems to raise is: whether or not Nitschel and Paul Baumann met at some stage, brought together by their similarities in religious convictions and similarities in their technical skills. Or perhaps both of them are one and the same person?

The second inventor of the telekinetic Influenzmaschine is considered to be Paul Baumann. He was born in 1917 in a multi-children farming family near Linden, Switzerland. Even as a pupil of local primary school he demonstrated unusual technical talents, building various experimental devices. At an older age he become known for his clock-making capabilities. Around 1950, together with twelve of his farming friends, he organized in Linden

the religious community Methernitha. (Address in 1991: Methernitha, CH-3517 Linden bei Bern, Switzerland.) The principles of this community recreate and implement the life of first Christian communes. When in 1991 I visited Methernitha, Baumann was one of the leaders of this commune. The work on his influenzmaschine Baumann began around 1965. The first two operational prototypes of this machine he built around the year 1978. He called these first machines "**Testatica**". (However, I never heard that he claimed actual inventing them and building them by himself.) Testatica were built as small, single-disk, telekinetic free energy devices, whose principles of operation were based on the Töpler's electrostatic machine (i.e. these free energy devices had only a single disk, whereas the function of a second disk was performed by stationary electrodes). Only two models of Testatica were ever built. They are operational until today, kept in the confines of the Methernitha community. They produce around 200 Watt of electric energy. Around 1983, this time supported by seven men from his new developmental team at Methernitha, Paul Baumann built the third model of his free energy device, having two counter-rotating disks. He called it the "Thesta-Distatica". The explanation for this name given to me was that "Thesta" means "prototype for testing", "Di" means "having two disks", whereas "statica" means "based on electrostatic interactions". The operation of this new free energy device was based on the Wimshurst electrostatic machine. The use of two disks allowed for a better induction of electrostatic charges, thus increasing the output from this free energy device. Some kind of curiosity can raise the fact that this machine displays a few details which are at least an unusual coincidence. For example the nominal diameters of both disks of the Thesta-Distatica are 548 mm, i.e. equal to the unit of length in this monograph called the "cosmic cubit" and used by all advanced civilizations for the dimensioning of their Magnocraft-like spaceship (UFOs) - see equation (F16) in subsection F4.7. In 1991 Paul Baumann together with his 7-man strong developmental team began the completion of his next (fourth) telekinetic free energy device. The construction and most of technical details of this new machine remain unknown at the present stage, but various rumours spread around say that it is also based on the Wimshurst electrostatic machine, and that the diameter of its disks is around 2.2 meters (i.e. 4 "cosmic cubits"). For my best knowledge this (fourth) telekinetic einfluenzmaschine is not completed even today.

Soon after Testatica was built, i.e. from 1978, Paul Baumann made available all his machines for unlimited and free inspection by members of the general public. Sometimes visitors were even allowed to photograph and to measure the machines. Amongst inspecting people were numerous engineers and scientists. The number of people arriving to the Methernitha in order to see these wonder machines eventually increased to such an extent that it gradually disorganized the life of the around 250 people strong community. It is estimated that during the peak years of 1983-4 Baumann's machines were seen each day by around 10-20 people. In order to decrease the number of visitors, in 1984 a payment amounting to SFr1000 per person was introduced. However, this payment did not decrease the number of arriving people, while it brought to the hosts various tensions and problems. For this reason in 1985 the Methernitha took a radical decision to completely cease showing their machines. Instead, in 1989 a 26 minute-long documentary video about these devices was made, which replaced their demonstration (in 1991 this video, with the German, English, or French commentary, could be purchased directly from the Methernitha for the price of about 200 Swiss Franks). For the duration of 10 to 14 May 1991, I visited Methernitha with the hope of seeing their free energy devices. Unfortunately, they did not make an exception from their former decision and did not show the Thesta-Distatica to me. The only benefit that I accomplished from this trip to Switzerland was that I talked to around 10 people who had witnessed the operation of this machine with their own eyes, and also I had the honour of meeting and talking in person to the genius-inventor, Paul Baumann.

The third inventor of the telekinetic influenzmaschine is me - the author of this monograph. My invention was born from a need to describe this free energy device in the first edition of monograph [6]. When writing this edition I considered it to be my duty to also describe the famous Testa-Distatica. Unfortunately, I had no access to any description of this

device apart from the earlier mentioned very brief item from the Raum & Zeit, (nr 34, Juni/Juli 1988, page 94). However, knowing the action of the Telekinetic Effect, the general design of free energy devices, and the operation of Wimshurst electrostatic machine, I managed to work out and to describe in my monograph [6] how the telekinetic influenzmaschine should look and operate. The subsequent visit to the Methernitha almost three years later (i.e. in 1991), reassured me that all the key technical features of my invention, which I envisaged and designed, were almost identical to those already implemented in the existing model of the Thesta-Distatica. (Of course, I am forced by my strange circumstances to work solely in a theoretical manner, and thus I had no opportunity yet to build my devices.)

Three subsequent inventions of the same influenzmaschine by three inventors who did not know details of devices developed by others, confirm the correctness of the commonly prevailing opinion that when the right time for a given invention comes, then a number of people independently of each other are capable of conceiving this invention. This in turn can be interpreted as the indication that new inventions represent a kind of gift addressed to the whole mankind, not only to those few individuals who first conceived them.

There is a sad ending to the history of telekinetic influenzmaschinen. This is the fact that in spite being constructed and working perfectly, none of these wonder devices is allowed to work for the good of our civilisation. All of them are strangely suppressed in various ways by the same mysterious evil force that suppressed also other free energy devices described in this monograph. In turn the first builder of these devices met with a horrible death – like designed especially to scare other people from pursuing this invention.

LA2.3.2. Excuses of Methernitha for withdrawal of dissemination of Influenzmaschinen

When in 1991 I visited Methernitha, one of the questions that I asked my hosts was: why they do not undertake the serial production and dissemination of their wonder machine. In my personal opinion, this machine could save our civilisation from a self-destruction, and also could accelerate the freeing of humanity from claws of evil parasites from UFOs. As an answer the representative of Methernitha explained to me an excuse, which according to what I wrote in chapter VB, UFO-nauts most probably manipulated into minds of this commune, to motivate them for an infinitively long holding back the dissemination of their devices. According to this excuse, in case of dissemination of this wonder device already now, it is going to introduce more bad than good to our civilisation. For this reason, according to Methernitha, there is not yet the right time to initiate the production and sale of this machine. (This right time supposedly is to come only when our civilisation falls a victim of a global catastrophe that UFO-nauts are foretelling to us for a long time.) When I started to ask for details of this strange view – i.e. that this wonder devices is going to cause more bad than good, several negative consequences of the introduction of this machine to use was presented to me. Knowing the current situation in the world, the builders of the influennzmaschine are convinced, that apart from the commonly known and easy to predict desirable consequences of this device, it is also going to introduce much greater number of highly undesirable such consequences. On these negative consequences Methernitha concentrates the entire its attention, while it completely ignores the desirable consequences of this machine. Although I do not share the decision of Methernitha, because I believe that never there is going to be a situation that any invention is to introduce exclusively positive consequences (see the moral “Principle of Counterpolarity” described in subsection I4.1.1), for a scientific exactitude I decided to describe here and publish these predicted negative consequences that this machine is to introduce. After all, we must be fully aware not only the advantages, but also disadvantages of this wonder machine. So this subsection is to explain these undesirable consequences of the introduction of telekinetic free energy devices.

Although the reservations and arguments of the Methernitha constitute the major component of these negative consequences, in this subsection I have not limited myself to

repeating only what I heard from Methernitha. After all, I know about the philosophical fact of the existence of good and bad consequences for practically everything. Also, being an inventor myself, I am well familiar with the internal doubts and tortures that every creator of a device with breakthrough implications for our civilization faces while making decisions concerning the dissemination of his or her invention. In order to appreciate the responsibility and moral weight attached to such a decision, I suggest to you (i.e. the reader) to think for a moment what you would do if you would be the inventor of, let us say, the Magnocraft, and know that only one such vehicle is required to totally annihilate a country of the size of England in around 12 hours, and that no present weapon can oppose this vehicle. Would you promote this invention risking that the Magnocraft may fall into the hands of some irresponsible group or individual, who could utilize it for the destruction of the mankind, or would you rather forget about the Magnocraft completely? The above is reinforced by the fact that I know perfectly the principles of operation and phenomena that free energy devices induce. So I am able to predict further negative and destructive implications of these machines, which other people simply overlooked. So I additionally introduced and explained here also the predictions of negative implication of the use of free energy devices that stem from my own analyses and from my own knowledge of the operation of this device. This is because, if I am presenting here negative consequences of this device, I should make sure that this presentation is as complete as possible. After all, it is good to know in advance, that if misused or improperly used, instead of being a blessing, these devices could turn also into a curse of our civilization.

An example of the most obvious of the negative implications of building the telekinetic influenzmaschine, on which the Methernitha concentrates the most of its attention, is opening the way for the abuse of this device in military purposes. It is not difficult to imagine the military advantage that one side would gain over the other, if its army would have aeroplanes that have no limits to the range of their flights, submarines that do not need to emerge to the surface, tanks that do not require fuel, torpedoes that are capable of crossing entire oceans, missiles (e.g. telekinetic equivalents of present "cruise missiles") that are capable of reaching every distant target and the range of which is not limited by the amount of fuel, etc.

The other equally negative implication connected with the introduction of these machines to use, is the creation of an unexpected and rapid economic advantage that a country, or a block of countries, having such machine as a first, would gain over the rest of the world. As the cost of energy can constitute even up to 80% of the total cost of some products, having energy for free would allow the winning country to eliminate all its competition and in the matter of a few years to become the world's leading economic power and monopoly.

However, independently of these military and monopolistic threats, the completion of telekinetic influenzmaschinen would also introduce various hazards during their exclusive civil and unpreferential utilization. So let us now analyse briefly the most important out of these non-military effects, that the wide dissemination of free energy devices may cause. During learning about these hazards it is worth to remember, that their appearance in the manner and extend described here can take place only when our civilisation is to maintain the present philosophy of parasitism. But if there is a change of the commonly practiced philosophy, from the present immoral parasitism into the futuristic moral totalism, then many of the consequences described below may not appear at all, or appear – but be easily taken under control. (Note that such a global change of the prevailing philosophy can be triggered just by the introduction of telekinetic free energy devices.) Here is a list of the most important out of these undesirable effects that can be brought about by the wide non-military utilization of telekinetic free energy devices:

#1. The cooling of the Earth's climate. There are certain chemical reactions which bind heat of our atmosphere and convert this heat into various flammable substances. Examples of products obtained during such heat-binding reactions are coal and crude oil. In the event of the wide utilization of telekinetic influenzmaschinen, the production of this type of substances would rapidly grow. The reasons for this would be as follows:

- In order to boost food production, farmers would heat the soil, converting in this way the thermal energy from our atmosphere into raw organic matter.

- The free energy would encourage heating of water. This would be done not only for industrial purposes, and in homes (e.g. in swimming pools with flowing water), but also in natural water reservoirs (e.g. for farming tropical fish species). The subsequent flow of such warmed water to seas would cause the growth of plankton and organisms which would bound the atmospheric heat into their organic matter.

- To increase the fertility of the soil, most of the organic matter currently burnt would be recycled into the soil (to produce humus).

- In order to decrease pollution of the air, and also because of the inconvenience of present combustion devices, the burning of fossil fuels and organic matter (wood) would be stopped.

- The lack of a need for conventional energy sources would eliminate the present mining and burning of fossil fuels which release significant amounts of thermal energy bound in such substances as coal and oil.

In this manner the widespread use of influenzemaschinen would cause the subsequent binding and elimination of increasingly large amounts of heat from our atmosphere, thus gradually cooling the climate of Earth. This cooling in turn would disturb the ecological equilibrium, bringing about the return of the ice age with all its cataclysmic consequences (e.g. geological changes).

#2. The pollution of our atmosphere with huge amounts of undesirable, highly-active ozone. The effect of this pollution would be a reversal of the action of present "ozone hole". Apart from such obvious results as holding back the photosynthesis in vegetation, killing some needed micro-organisms, this could also accelerate the ageing process in people, intensify the corrosion of metals, rapidly wearing out and tearing of solid objects, undermining the processes that keep people healthy, etc. In the case of especially intensive emission of ozone, it could even happen that the very life-giving conditions of our planet can be undermined.

#3. The triggering of the explosion of unneeded production. Presently the production of any goods is limited by the costs of energy required for their manufacture. However, when energy will be for free, producers will be limited only by the absorption of the market. In order to increase this absorption, they will apply various tricks, for example:

- The production of a disposable packaging which requires more energy and materials than the product itself.

- Convincing the population (via advertisements, fashion, social role models, new customs) of needs which in fact do not exist. An example of how this is already being done is the multiplying of various commercially oriented events (e.g. fathers day, mothers day, valentine's day) and then putting social pressures on people forcing them to purchase various unneeded goods made especially for these occasions.

- The intensification of production which serves exclusively for entertainment, shows, advertisements.

- The production of increasingly large proportion of disposable goods prepared for one use only.

In turn such marketing strategy will quickly convert our planet into a large rubbish dump overflowing with used packaging, disposable products, one-time entertainment goods, etc.

#4. The increase of poorness of the so-called "third world" and the lengthening of the distance between rich and poor countries. In the present circumstances of expensive energy, the production of many goods at the spot is not profitable and it is more economic to bring these goods from other countries. Because of this bringing, poor countries are still able to offer to the rest of world at least a part of the resources that they have. But in situation, when energy is going to be for free, many rich countries will not be prepared to put us with the lack of reliability, with constant problems, with dangers, and with inconvenience of the trade with poor countries. Thus they are rather going to produce the required goods on

their own soil. For example, instead of importing bananas from dangerous and unreliable “banana republics”, it become much easier to build heated glasshouses on the own soil and to produce bananas in own country with a higher efficiency, higher success ratio, and in a manner that fulfils all standards and requirements of the local market.

#5. The fall and disintegration of the present concepts of worth, quality, good versus bad, etc. Because of the to-date high costs of the production of some goods, our civilization established the system of values in which such attributes as permanency, reliability, unchangeability, productivity, diligence, are appreciated the most. However, in the case of decrease in costs of production, these old values will inevitably be replaced by new ones, more compatible with human nature. Thus with the elapse of time the production of disposable, one-use goods will increase. The system of value of these goods will be described by a different set of attributes, such as: appearance, pleasantness, convenience, instantaneity, etc. This tendency is already observed in many products such as milk containers, napkins, handkerchiefs, syringes, shavers, toothbrushes, etc. In the final effect all products will probably be made for single use only, as it is more pleasant to always use entirely new things than second-hand ones. Of course these changes in the material domain will be transferred also into the philosophical domain. Thus, instead of being faithful to an old friendship, partnership, lover, employer, country, etc., society will display tendencies for changing everything into a newer one (it is interesting that already now, the more technologically advanced a given nation is, the greater such tendency seems to be displayed). In turn the lack of permanency and stability is the beginning of chaos. The above will be additionally amplified by the desire of producers to increase the sale of their goods, which will result in the promotion of a consuming, graspy, lazy, and egoistic lifestyle.

#6. The unimaginable migration of people, instability of populations, and demographic explosion. The fact that people currently spend most of their life in the place of their residence mainly results from the costs and inconvenience of travelling. But when travelling becomes almost free, and when people can travel with their whole house and possessions then everyone will be on the move. Instead of the nearest shop people will go shopping to the next city or even country. When they become bored with one place, they will move to another. Bad weather will initiate the shifting. In the final effect, the whole population of our planet will be in a state of continuous move, disorganizing production, choking highways and transport facilities, and making any control over crime, conduct, morality, health, epidemics, etc., almost impossible. Contributing to the above would be a demographic explosion which would be the effect of reducing the costs of bringing up children (these costs today are one of the main breaks that limit the number of children).

#7. The devaluation and fall of the present structures of power. The organization of countries and societies on the present principles will not be possible any longer after the introduction of these machines. The main reasons for this are as follows:

- The telekinetic free energy devices make very difficult, if not impossible, the execution of payments for the energy they produce. Even if the authorities introduced the law enforcing that newly-sold influenzmaschines must be provided with electricity meters, these machines are simple enough for many people to make them on their own, and enough small to be secretly used. Payments for the energy used in most of the countries lie at the foundations of the present system of taxes. In turn the system of taxes is the backbone of almost every country. Therefore, in the face of impossibility of charging for the energy consumed, the whole present structure of countries and governments may collapse.

- The influenzmaschine undermines the present orthodox scientific and educational establishment. Contemporary societies raise numerous objections against philosophical and moral foundations of present orthodox science and education. For example these objections state that science in the current form leads our civilization to destruction. By intentional removal of the spiritual element science introduces a growing disproportion between technological and spiritual development. Therefore, an increasingly growing number of people in the world call for the reformation of science and education. The reason for which this

reformation was not forced upon science as yet, is the lack of an obvious proof that present science is wrong. But the influenzmaschine and other free energy devices provide just such a proof. Therefore the wide introduction of these machines will probably release the long suppressed need for the total reformation of orthodox science and education.

- The Concept of Dipolar Gravity, from which the explanation for the operation of influenzmaschinen is derived, reforms also the foundation of religion. It is because in this concept, the substance which prevails in the other world and from which the counter-material copies of all objects are made, in its natural state is capable of thinking. Therefore, in the Concept of Dipolar Gravity, the entire universe is a kind of a huge brain (i.e. the "universal intellect" by religions called God), in which we all are submerged and which "hears" all our thoughts. Apart from the physical laws, this intellect also introduces and executes a set of "moral laws" (e.g. the "Boomerang Principle" which states approximately that "whatsoever a given person does to others, after a purposely delayed time exactly the same will be done to this person") which is a component of every religion. The Concept of Dipolar Gravity also teaches that the universal intellect can be objectively investigated with the use of tools which currently are domain of science (not religion). In this way, the dissemination of influenzmaschinen which represent a physical proof for the correctness of the Concept of Dipolar Gravity, may cause the fall of present religious institutions and structures, and the adoption of this new concept as a new scientific-technical-religious philosophy of the mankind.

The country, science, education, and religion are the foundations of present societies. Their possible undermining could cause a revolution of the extend unknown in the history of mankind. In the course of this revolution chaos and anarchy could begin to prevail which could mark the end of our civilization as we know it.

* * *

Being aware of the majority of the above negative consequences of the introduction of telekinetic influenzmaschinen to a commercial use, Paul Baumann and his developmental team made the decision of delaying the spreading out of the Thesta-Distatica's technology. When I talked to them in 1991, they told me that in their opinion after the next ten years the conditions on our planet will prevail which will be more favourable towards the release of this revolutionary invention. (I should stress, that already 13 years passed since that discussion, and the Thesta-Distatica machine still is not allowed to begin its service for the humanity.) In the meantime, while waiting for the arrival of these more favourable times, the gradual improvement and perfecting of the Thesta-Distatica should be undertaken.

Readers have probably realized by now that myself, although having the highest respect and admiration for Baumann's technical genius, I do not approve of the decision of the Methernitha to delay the commercialization of the Thesta-Distatica (if I did approve, I would not have published the principles of this device in this monograph). I agree that all the changes in societies described above will in fact be triggered to some extent by the introduction of this wonder machine. However, I also believe (although I do not exclude the possibility that I may be wrong) that:

#I. These changes are to be induced by the thoughtless nature of people and by their philosophy, not by free energy devices. Thus, if only the favourable conditions begin to prevail, similar changes will appear even if people do not have access to free energy devices.

#II. The appearance of these changes will release appropriate reactions within the mentality and philosophies of people. These reactions will in turn neutralize the majority of undesirable consequences described above. In the final effect, the changes described here will actually facilitate the evolution of the future society whose lifestyle and principles will be much better than ours.

#III. According to the Law of Counterpolarity, it is never going to be possible to build a machine or a device, which would introduce exclusively positive consequences.

Furthermore, according to the action of moral laws, **the inventor, discoverer, creator, or supplier of a given device does not bear the moral responsibility for the manner in which his or her creation is going to be used**, but only for the fact of making it available to

humanity and for providing people with all information that he or she gathered about this creation. In addition to these moral factors that argue for the fast dissemination of telekinetic influenzmaschinen, it is also sure that these telekinetic free energy devices at the same time create the chance for saving our civilization from gradual self-destruction caused by currently prevailing plagues (such as poisoning of the natural environment, diminishing of natural resources, the devaluation of authority, the moral decay, etc.). Furthermore, they open new horizons which possibly are going to wake up our civilisation from the present illusion, and convince it to begin defending itself from these morally decadent UFO-nauts that occupy our planet. For example, the introduction of telekinetic free energy devices to wide use, is going to provide a visual proof that the Concept of Dipolar Gravity – which forecasted them and explained their operation, is absolutely correct. This in turn should make think even the most devoted worshipers of TV sets, letting them know that practically everything that this concept states is true and correct. This means that not only free energy devices do exist and work - as this concept describes them, but that also moral laws do exist and work, that there is the superior being called the “universal intellect” which judges every single our action, that totalizm is the correct philosophy of life, etc. So these people, who after the spread of telekinetic free energy devices would still murder others, would live immoral lives, and would break moral laws, would be simply stupid idiots that ask for consequences which without doubt are going to get them. Thus, in order to act accordingly to my own principles, I decided to support all efforts aimed at the completion of other working prototypes of telekinetic influenzmaschinen, and aimed at putting this wonder device into the service of our civilization. (Note that in my extremely difficult personal circumstances, I am unable to build myself the devices that I invented.) Thus, the publishing in this monograph exact descriptions of the design and operation of these devices, and making these descriptions available to every potential builder, is my contribution, as well as the first and the most important step, to these efforts.

LA2.3.3. Design, main circuitry, and operation of the telekinetic influenzmaschine

Motto of this subsection: “The totaliztic help does not depend on doing something for someone, but on providing such encouragement, information, and directing, that this someone could do it by himself.”

I never have had the opportunity to personally see the Thesta-Distatica. Thus the description provided in this subsection is NOT my report from examining of that particular Swiss machine. It is rather the documentation of a telekinetic influenzmaschine invented and developed by myself on the basis of my knowledge and my research on the Telekinetic Effect. Therefore this machine is called here a “**telekinetic influenzmaschine of my own invention**”, or simply a “telekinetic influenzmaschine”. The use of this name emphasizes, that the device I am describing here is not exactly the famous Thesta-Distatica already build by the Methernitha, but a machine of my own invention. However, I purposely designed my machine in such a manner, that the appearance, main components, and effects of operation of it, are intended to correspond to those from the Swiss Thesta-Distatica. The correspondence of the free energy device of my invention documented here, to the design and operation of the Thesta-Distatica was verified and confirmed by me on the basis of all data that were available. This data originated from my personal discussions with people who observed this machine with their own eyes, correspondence with VENE and Methernitha, photographs and the documentary video of the Thesta-Distatica, and also from all descriptions and drawings prepared by other investigators, which I could get hold of. Unfortunately, the absolute agreeability of the telekinetic influenzmaschine of my invention that I am describing here, with the Thesta-Distatica, cannot be fully guaranteed.

The **mechanical structure** of the Thesta-Distatica is shown in **Figure LA5**. Part (c) of Figure LA5 shows the framework of this machine. The telekinetic influenzmaschine is built on

a wooden framework consisting of two beams (i.e. a horizontal basis (b), and a vertical column (t) at the back side of the machine) that are put together into the shape of the letter "T" reversed upside down - see part (c) of Figure LA5. To the upper end of the column (t) a single permanent magnet (Mo) is attached, whose field points out at electrodes of the both disks of the machine, forming close magnetic circuit with another magnet (M) attached to the head (ho). The column (t) holds the axel (O) protruding forward in middle of the height. This axel carries bearings of two rotary disks, the frontal one marked (dc), and the back one marked (dg). These disks can rotate independently from each other in two opposite directions. In the frontal part of the Thesta-Distatica (i.e. facing both disks) additional carrying frame made of transparent plexiglas is attached. This frame includes a central flat beam (vc) oriented vertically, two side flat beams (vl) and (vr) also oriented vertically - which hold induction heads (h1) to (h4), a horizontal shelf (sl) carrying capacitors (I1), (I2) and (I3), and a horizontal beam (sh) that carries the collection heads (H-) and (H+).

The main kinetic components of this free energy device are shown in part (d) of Figure LA5. The most important of these are two plexiglass disks that rotate on a common axel in two opposite directions. The front disk, called "the cloud" by the Methernitha, is marked as (dc), whereas the back one, called "the ground", is marked as (dg). Both disks have a diameter of 548 mm and a thickness of 5 mm. To the outside (means frontal) surface of the front disk (dc) - named the cloud, and also to both surfaces of the back disk (dg) - named the ground, 48 leaf-like electrodes, called "lamellas" by the Methernitha, are attached. Each of these electrodes is perforated into the shape of a ladder concentrically narrowing down, and has dimensions: length 190 mm, maximal width 22 mm, and thickness 2 mm. These electrodes are cut out of a steel plate and coated with chrome for the protection from oxidising action of ozone (I heard the opinion that much more effective, but also much more expensive, would be electrodes made of a gold or silver plate.) People who inspected the Thesta-Distatica claim that the electrodes display a slight magnetization. However, at this stage it is difficult to determine if this magnetization is intentional, or is a by-product (residue magnetization) of the co-operation between the electrodes and magnets of the spindle (Ts) and head (ho). Both disks, i.e. the front (dc) and the back (dg) are assembled on bearings attached to the axel (O) sticking out from the column (t) at half of the height. Under the disks, column (t) has also attached bearings of the spindle (Ts). This spindle holds a small disk with a diameter $d=120$ mm, which carries magnets (m), and two parallel pulleys (Pb) and (Pr). The first (Pb) of these pulleys (this closer to the magnets) has its own bearings, which allow it to rotate independently from the rotations of the spindle (Ts). In turn the other pulley (Pr) is wedged permanently with the spindle (Ts). The axis of the rotation of the spindle (Ts) is perpendicular to the axis of the rotation of both large disks (dc) and (dg). The pulleys (Pb) and (Pr) of the spindle (Ts) are linked by a single elastic belt (B) with the pulleys (Pc) and (Pg) attached to the outside surfaces of each large disk (dc) and (dg). Thus the belt (B) forms a kinetic link that couples together all the rotary parts of the telekinetic influenzmaschine, forming from them a single-function unit. In this unit, the rotating of any part forces the rotation of both disks (dc) and (dg) in two opposite directions, as well as the rotation of the spindle (Ts). Although the existing telekinetic influenzmaschinen do not have a starting crank, I would suggest that in order to ignite and test own prototypes, developers who work on these machines supply them into such a crank.

The subsequent electric components of the telekinetic influenzmaschine are shown in parts (a), (b) and (e) of Figure LA5, and also on Figure LA6. One of the most important of these components are four collecting heads (H-) and (H+), wired together into two couples - see part (b) in Figure LA5. In each of these couples, one head co-operates with the front disk (see Figure LA5-b), whereas the other - with the back disk (Figure LA5-a). Directly connected to these heads (H) through a wire of especially high capacity are two powerful capacitors (L-) and (L+). (The construction of these capacitors (L-) and (L+) is the commercial secret of the Methernitha and there is a lot of speculations regarding their details. However, from the operation of the telekinetic influenzmaschine it can be deduced that they must represent a

kind of crossing between high power capacitors and autotransformers.) The electrostatic charges accumulated in the capacitors (L) are subsequently supplied to a user via output terminals (Wo) with two poles (-) and (+). The function similar to that of the capacitors (L), but catering for the needs of the machine itself (i.e. not for the outside user) are two long capacitors (Lb-) and (Lb+) shaped like tubes, assembled on the back side of the machine (Figure LA5-a). The active element of these capacitors (Lb), similarly like for capacitors (L), are wire coils. Capacitors (Lb) are connected via resistors (Rr) and (Rl) to two collecting combs (C-) and (C+) and two induction heads (h5-) and (h6+), also placed on the back side of the machine. The collecting combs (C) and induction heads (h5), (h6) have their equivalents on the front side in four front induction heads, in the part (b) of Figure LA5 marked as (h1+), (h2-), (h3+) and (h4-). These heads are connected together via a small capacitor marked as (C2). The neutral induction head (ho) located on the very top, is connected with two capacitors marked as (C4) and (C5) and two inductors marked (I₁) and (I₂). These inductors (I₁) and (I₂) take the form of horse-shoe permanent magnets shaped like the reversed letter "U" having two coils wired bifilar around its two ends – see also the description of telekinetic battery provided in subsection LA2.4.1. The electrical components described above are complemented with a “reciprocator” or a “tube” (T) placed on the top of column (t), and with a dynamo-motor (Dm) attached to the back of the column (t) near the head from the spindle (Ts) - both these parts are plugged into the circuit of regulation of the rotational speed of all kinetic components of the telekinetic influenzmaschine.

The telekinetic influenzmaschine incorporates several **special components**, which are extremely vital for the operation of it. Two most important of these special components are the tube (T) and two inductors (I₁) and (I₂). Both these components are explained in details when the design and operation of telekinetic battery is being explained (see subsection LA2.4). So in this subsection these are not discussed again. The third slightly different component of telekinetic influenzmaschine, are the collecting capacitors marked as (L-), (L+), (Lb-) and (Lb+). These capacitors fulfil the function very similar to the leyden jars in electrostatic Wimshurst machine. It is worth mentioning that the Methernitha introduced special modifications to the capacitors (L-) and (L+), so that apart from the accumulation of charges they could also decrease the output voltage (e.g. the Thesta-Distatica normally produces around 700 to 900 Volt, however, due to the use of these capacitors of a special design this voltage is decreased to around 250 Volt required for the use in ordinary households). But this additional function represents a kind of "extra" addition and has nothing to do with the principles of operation of this machine - i.e. the telekinetic influenzmaschine would also perfectly operate if fitted with any other capacitors in the place of (L), only that then its output voltage would be much higher.

The electric connections and wiring of the telekinetic influenzmaschine are shown in **Figure LA6**. These form three basic functional components, in the description below marked as (#1) the electrostatic induction motor, (#2) the telekinetic battery, and (#3) the rotational velocity controller. The **general principle of operation** of these three components is very simple. Namely the electrostatic induction motor (#1) consumes a part of the electric current that is supplied by the telekinetic battery (#2) to the capacitors (L-) and (L+). This current is converted into the mechanical motion of spinning of both disks (dc) and (dg) from the telekinetic influenzmaschine. In turn the rotation of the disk (dc) generates a sequence of stable electrical impulses on the head (ho). These impulses are then fed as the input of the telekinetic battery (#2). In the battery this impulses cause that an AC electric current is generated and supplied to capacitors (L-) and (L+). A part of this AC electricity can be used for supplying the motor (#1) into energy. In this way the electric motor (#1) sustains the operation of the telekinetic battery (#2), while the telekinetic battery (#2) sustains the rotation of the motor (#1). In order all this is happening in a stable manner, the constant speed of the motor (#1) is controlled by the special rotational velocity controller (#3). This controller (#3) maintains the constant speed of the motor (#1) and the front disk (dc) of it, thus maintaining the stable operation of the battery (#2).

Now we will proceed with the explanation of the operation and components for all these basic components of the telekinetic influenzmaschine.

#1. The electrostatic induction motor. This motor consumes the majority of the components and circuits of the telekinetic influenzmaschine. It is so designed and build, that it consumes electrical energy accumulated in capacitors (L-) and (L+), and converts this energy into the rotational motion of disks (dc) and (dg). (This electrical energy is supplied to (L-) and (L+) by the telekinetic battery described below.) In the telekinetic influenzmaschine this motor performs two functions. The first of these is purely psychological. It depends on providing a visual proof, that this machine works and that it generates the rotary motion practically infinitively, in spite of the fact that it is NOT supplied in any form of energy. (I.e. it proves illustratively, that the construction of “perpetuum mobile” is possible, in spite that our present orthodox science is denying such a possibility.) The second function of this motor is to form the so-called “pulser” for the telekinetic battery. This function depends on the generation by the front disk (dc) of this motor, of a series of impulses for Europe having the frequency of $f=50$ Hz (while $f=60$ Hz for America). These impulses are collected from the electrodes of the front disk (dc) by the head (ho), and then forwarded to the entry to telekinetic battery.

The principle of operation of the electrostatic induction motor described here is a reversal of the principle of electrostatic machine (e.g. the Töpler machine or the Wimshurst machine). Only that, in fact this motor is working on an AC current. This motor is composed from the following components wired together as this is shown in Figure LA6: two pairs of induction heads (H-) and (H+) and collecting combs (G-) and (G+) – notice that each of these pairs cooperates with electrodes of both disks, i.e. front and back; special capacitors (L-) and (L+). With these parts the output terminal (Wo) is connected, which supplies to the user the energy produced by the telekinetic influenzmaschine. This output terminal collects the AC electrical current produced by the telekinetic influenzmaschine and supplies it to an end user.

In a brief summary the operation of the electrostatic induction motor is as follows. Electrical charges are induced on electrodes of both disks of the telekinetic influenzmaschine by heads (H-) and (H+). This induction is occurring in one position of these disks. Then the charges are collected with the collecting combs (G-) and (G+) in other position of these disks. These charges originate from capacitors (L-) and (L+), the ground plates of which are linked with each other, and from which these charges can be drawn by the user through the exit terminal (Wo). The appropriate distribution of these electrostatic charges on both disks induces electrostatic forces, which cause the rotational motion of these disks. Description of these forces is contained in monograph [6/2]. Details of this operation are rather complex and require thorough studies of principles of electrostatic induction machines, plus the reversal of these principles so that they form an electrostatic induction motor.

In the telekinetic influenzmaschine that has two disks, such as e.g. the Swiss Thesta-Distatica, actually two such electrostatic induction motors must be present. Namely the frontal one and the back one. Each one of these is supplied from a separate pair of capacitors. However, for the actual operation of this machine only a single disk and a single motor, namely the frontal one, is needed. The back one is just only an additional kinetic ballast, which functionally is not utilised at all, and serves only for creating visual effects.

The frontal electrostatic motor is absolutely essential for the operation of this machine. It is composed of the front disk (dc), to which four induction heads are aligned, in Figures LA5 and LA6 marked as (h1), (h2), (h3) and (h4). These heads are connected together via a capacitor (C2). It is this motor that performs the function of the “pulser” for the telekinetic battery. The operation of this motor results from the formation such a distribution of electrostatic potentials on the frontal disk (dc) of the motor, that in confrontation with the potentials of heads (h1) to (h4), this distribution creates the propelling electrostatic forces which rotate the disk in (n') direction. The mechanism of this operation is shown in part (c) of Figure 8 from monograph [6/2], and is explained over there in details in item 2 from subsection 4.3.1.

The back electrostatic induction motor, is non-vital for the operation of this machine. It is placed on the back of the telekinetic influenzmaschine. It is composed of the back disk (dg), above the surface of which two induction heads marked (h5) and (h6) and two collecting combs (G-) and (G+) are fitted. These heads and combs co-operate with the back capacitors (Lb-) and (Lb+). Together with them they form another complete circuit of a back electrostatic induction motor. The operation of this motor is very similar as the operation of the frontal motor. Only that it takes electric charges from the back capacitors (Lb-) and (Lb+), and that it transforms these charges into the motion of the back disk (dg).

At this point it should be emphasized again, that the back motor, as well as the back disk (dg), are completely unnecessary for the operation of the telekinetic influenzmaschine. Their function can be well replaced by the permanent heads that are electrified with charges originating from capacitors (L-) and (L+). So in case of possible removal of this back disk and motor, the two-disk telekinetic influenzmaschine described here would transform into a single disk machine similar to the Töpler's electrostatic device (means into the original Brosan's device).

#2. The telekinetic battery. The telekinetic battery is the most vital functional component of the telekinetic influenzmaschine of my invention, shown in Figure LA6. After all, it is this battery that generates electrical current and thus supplies this machine and the external user into free electrical energy. This battery is almost identical as the one that I am describing in subsection LA2.4.1. The electric circuits of this battery begin at the electrode (ho), which in this battery performs the function of the pulser (Q). In turn they finish on capacitors (L-) and (L+), which accumulate the electrical energy that this battery generates. The most vital components of this telekinetic battery are two inductors (I_1) and (I_2). They are connected with capacitors (C1) and (C3). It is also connected to the tube (reciprocator) marked (T). Together with this tube the connections and the operation of this battery almost exactly correspond to the operation of the telekinetic battery described in subsection LA2.4 – where the readers may gain the understanding of it. The only difference in the circuitry of this battery is the pulser. Instead of the resonance chamber (D) and the quartz crystal (Q) – as this takes the place in the telekinetic battery shown in Figure LA7, in the telekinetic influenzmaschine the electrical impulses are formed by charges on the electrodes (E) from the frontal disk (dc), which (electrodes) are passing under the head (ho). So in the telekinetic influenzmaschine function of the pulser is performed by the spinning electrodes (E) and by the head (ho).

The extremely vital attribute of the telekinetic battery is, that it generates the alternating current (AC). The frequency (f) of this AC current is dependent on the frequency of electrical impulses that are generated by the pulser. So in the telekinetic influenzmaschine it depends on the number of electrodes (e) which move under the head (ho), and thus which generate the impulses forwarded to the telekinetic battery, and on the rotational velocity (n) with which revolves the disk (dc) with electrodes (e). This frequency can be expressed with the equation:

$$F = ne \quad (1LA2.3.3)$$

It is obvious that this frequency must coincide with the frequency $f = 50$ Hz of the conventional electricity supply in Europe (or with the frequency $f = 60$ Hz of such supply in America). This means that for the practical number of electrodes $e = 48$ on the front disk (dc) of the telekinetic influenzmaschine, this frequency is defining the rotational velocity of the front disk at the value that in Europe is equal to $n = 62.6$ revolution per minute (RPM).

In spite of the claims of various people, that the Thesta-Distatica produces a direct current (DC), in fact this telekinetic influenzmaschine **must be the source of the alternating current (AC)** that is capable of a direct supply of present electrical appliances in our houses. After all, this current is generated in it by the telekinetic battery. In turn such a battery is able to only generate the alternating current (AC).

The unique attribute of the electricity generated by the telekinetic batteries, and thus also by the telekinetic influenzmaschine, is that their variations in time introduce a telekinetic asymmetry. Thus all phenomena induced by this device display consequences of the Telekinetic Effect in action. In the final result, near such telekinetic influenzmaschinen various

telekinetic “**supernatural phenomena**” are going to appear, which are not understood by the present orthodox science, but which are characteristic for the Telekinetic Effect – see their list provided near the end of subsection LB2. For example, bulbs supplied from this machine are going to show the tendency for unlimitedly long life, people exposed to the action of the heat generated by electricity from this machine may rapidly heal and regain perfect vigour, people present in the circle of light generated by this machine are going to experience telepathy and insights into the future (visions), vegetation in the vicinity of this machine are going to grow faster, healthier, and to larger sizes, etc. No wonder, that experiencing this type of phenomena, people from Methernitha surround their machine with almost a religious worship.

The above should be complemented with the information about a strange curiosity. Namely, this telekinetic free energy device contains the telekinetic battery build into it. On the other hand, the true functions as well as the principles of operation of this battery remain unknown to the builders of this machine. All this together, is one of the most convincing evidences, that the telekinetic influenzmaschinen were given to our civilisation, not build by us. The generous creatures who gave this machine to humanity, are some sort of totaliztic beings that are more advanced than us, and sympathising with the doomed fate of humanity. It is almost sure, that they are the same beings, which gifted humanity with the telepathic pyramid described in subsection N2. Unfortunately, the evil UFO-nauts who currently occupy our planet, are not willing to allow this machine to work for the good of humanity. So UFO-nauts blocked the distribution of this wonder device, through hypnotic manipulations on minds of members of the hermetic Methernitha community.

One of the most vital circuits of the telekinetic battery is the circuit of the “pulsar”. This circuit includes the so-called “neutral” induction head (ho) which represents the electric potential of the earth, connected to the both wires of the output terminal's circuit (W) via inductors (I_1) and (I_2), capacitors (C1) and (C3) and capacitors (C4) and (C5).

#3. The rotational velocity controller. This component of the telekinetic influenzmaschine is aimed at regulating the constant rotational velocity (n) of the front disk (dc). The point is that this velocity always supposed to coincide with the required velocity of $n = 62.6$ revolutions per minute (RPM), which is necessary for generating the AC electricity of the European frequency of $f = 50$ Hz. This controller is connected with the circuitry of the electrostatic induction motor (#1) via the tube (T) and two resistors (R1) and (R2), forming with this circuitry the negative (opposing) feedback. The components of the rotational velocity controller include the tube (T) mounted at the top of the vertical column of the framework of this machine, resistors (R1) and (R2) that produce a higher inertia of the control reactions, and the dynamo-motor (Dm) placed at the back of the machine, by the disk of the spindle (Ts) and within the range of magnets (m). The key to understanding the operation of this controller is the dynamo-motor (Dm). This (Dm) is a device with the reversible operation, which is a cross between a motor and a dynamo (generator). Thus one time it works as an electric motor. So it consumes electricity drawn from the circuitry of the telekinetic influenzmaschine, and converts this electricity into the rotations of the spindle (Ts). Another time it works as a dynamo (i.e. electricity generator). This means that it then consumes (holds back) the rotational motion of the spindle (Ts), and changes this motion into an electric current that is forwarded to circuitry of the telekinetic influenzmaschine. The function of the rotor in this dynamo-motor is performed by the spindle (Ts) holding a disk which holds 6 or 8 magnets (m).

The dynamo-motor (Dm) **works as a motor** only when the rotational velocity of disk (dc) – and thus also the spindle (Ts) – falls down below the required value of $n = 62.6$ revolutions per minute (RPM). (Means when this velocity is too slow.) In such a case the electricity supplied to (Dm) from the circuits of the influenzmaschine causes the acceleration of the spindle (Ts). In turn the acceleration of the rotations of this spindle, via the belt (B) and pulleys, increases the rotational velocity of the disk (dc). So through this mechanism, it increases the initially too slow velocity of the disk (dc) to the required value of $n = 62.6$ RPM.

The dynamo-motor (Dm) begins to **operate as an electricity generator** (dynamo), means as an electric brake, when the rotational speed of both disks increases above the

required value of 62.6 RPM. (Means when it is too high.) In such a case the dynamo-motor (Dm) begins to operate as an electric brake which transforms the rotations of the spindle (Ts) into an electric current of the polarity indicated in Figure LA6 near the circuit's label (D). This current, because of the blocking action of the tube (T), is then subtracted from the current in the circuits of *influenzmaschine*, thus causing the fall of effectiveness of the electrostatic motor. This in turn slows down the rotation of the disk (dc). Such a mechanism of the operation of (Dm) as a dynamo in the final effect causes the fall of the rotational speed of both disks (dc) and (dg) to the required level of $n=62.6$ RPM.

The operation of the telekinetic *influenzmaschine* is initiated with a manual rotation of one of its disks, e.g. (dc). This rotation is transmitted by the belt (B) to the spindle (Ts) and then transformed into the opposite rotations of the other disk, e.g. (dg). The rotation of the front disk (dc) induces the sequence of electric impulses on the head (ho). These impulses are forwarded to the telekinetic battery, where they are reinforced with additional energy and send to the capacitors (L-) and (L+). From these capacitors the electrical energy flows back to the circuits of the electrostatic induction motors, which sustain the rotation of both disks (dc) and (dg). The transmission belt (B) intercepts the rotational motion of both disks (dc) and (dg) and propels the spindle (Ts). This spindle (Ts) causes the production or consumption of additional electricity in the dynamo-motor (Dm), thus controlling the rotational speed of the disk (dc) at the required level of $n=62.6$ RPM, and also stabilizing the rotation of the remaining kinetic components of the machine. In the result, this machine generates an AC electricity of constant and stable frequency $f=50$ Hz. This electricity is accumulated in the capacitors (L) of a special design, and finally supplied to the user via the output terminals (Wo).

While analysing the electrical diagram and also the principles of operation of the telekinetic *influenzmaschine* described here, it hits the eye that in fact it was designed NOT as a symmetrical two-disk free energy device similar to the Wimshurst machine, but as a single-disk Töpler device to which an additional second disk was artificially added. Expressing this in another words, it appears that the Swiss Thesta-Distatica is simply a single disk Testatica (or the Brosan's telekinetic free energy device), which is furnished with a second disk that cooperates with some components of this device, e.g. with the tube (T) or the dynamo-motor (Dm). Thus the Thesta-Distatica was not improved neither in the electrical or operational sense in comparison to the Brosan's telekinetic free energy devices. But the mechanical structure and the electrical circuitry become much more complicated in it. So at this point a question arises, why Baumann and his developmental team decided to depart from the concept of a simple in design and operation, and thus more prone for the improvements of the performance, one disk Testatica free energy device (by Brosan). Was it again an intrigue of UFO-nauts to make the duplication of this machine by other inventors much more difficult. Or perhaps the reason was purely psychological and boiled down to the wish to have the "own" machine that distinctly differs from the original Brosan's prototypes? In both cases the motives for the change of design was of a hidden agenda type (e.g. the wish to "father" own machine) not of the technical type (e.g. the improvement of the performance or the production of this machine). In turn, it is well known, that masters in just such manipulation on hidden motives of humans actions are UFO-nauts who occupy us – see subsection VB4.2. So this strongly indicates that behind all these improbable difficulties with the inclusion of the telekinetic *influenzmaschinen* to the technical accomplishments of our civilisations, are hiding our cosmic occupants from UFOs.

The technical problems of the telekinetic *influenzmaschine* which are yet to be solved urgently are: (1) the production of a high voltage combined with a small amperage (this problem seems to be a reversal of the problem with the N-Machine); (2) the high sensitivity of this machine to atmospheric conditions, and (3) the significant instability (fluctuation) of the output, reaching around 25%, which leads to fluctuation of the power supplied. (This fluctuation of the power most probably results from the lack of an efficient control mechanism that would adjust the parameters of output to user requirements. After all, the dynamo-motor (Dm) controls only the rotational velocity, means the frequency (f), not the power output from

this machine.) Furthermore, as every other technical device, the present implementation of the telekinetic influenzmaschine (i.e. the Thesta-Distatica) has several undesirable side effects. The most vital out of these is that this telekinetic free energy device produces a lot of ultraviolet light, which is detrimental to eyes of people who stay nearby for a longer period of time. For example in Methernitha people who worked on the development of this machine in past were easily recognisable because they had red eyes. Also the electrostatic field that prevails between two disks leads to a strong ionisation of the air and to the production of a quantity of ozone. Although this ozone probably contributes towards the removal of the ozone hole in our atmosphere, at the direct contact it causes the rusting of all metal objects that are present in a given room. Thus, in practice, the design of the telekinetic influenzmaschine still requires fine-tuning before its effectiveness, reliability, and stability reach the level of the present electricity producing generators of the first generation. But this fine-tuning is a small problem, and can be fixed quickly - if our civilisation gains a chance of implementing this machine. The major problem with this machine is that UFO-nauts are controlling it already, and it will be a difficult task for us to tear it out of their grabby claws.

LA2.3.4. How to arrange own experiments on constructing the telekinetic Influenzmaschine

The operation of the telekinetic influenzmaschine combines the action of as many as three of the following devices: (#1) an electrostatic induction motor, (#2) a telekinetic battery, and (#3) an electro-mechanical speed controller (i.e. the dynamo-motor – see (Dm) in Figure LA6). The superposition of these functions into a single machine is a task extremely difficult for a scientifically non-trained inventor. Therefore, in order to facilitate this superposition for these readers who (at their own risk and cost) would like to try their skills and to undertake a challenge of building their own version of the telekinetic influenzmaschine, I have listed below the subsequent steps that should lead to the most effective accomplishment of this task. These steps are:

#1. Learning principles of electrostatic machines. Such a learning requires a detailed familiarization with the design and operation of the Töpler and Wimshurst electrostatic machines. These machines are quite well described in old Physics textbooks on electricity and magnetism. Most of the textbooks describing these machines were published from about the 1860s to about the 1930s. For example the 14th edition of "The Encyclopaedia Britannica", which was published in London in 1929, in its volume 8: Educ - Extr, under the topic "Electrical Machine" (pages 143-144) contains over two pages of descriptions of various electrostatic machines, in this number also the Töpler and Wimshurst machines. However, neither the earlier nor later editions of the same encyclopaedia include descriptions of these machines.

#2. Familiarization with the design and operation of the telekinetic influenzmaschine. For this it is necessary to study in some detail the content of this monograph, and also to study all other publications which become available about this device. Extremely helpful would also be to study the documentary video prepared by the Methernitha about the operation of the Swiss Thesta-Distatica. In 1991 copies of this video could be obtained directly from the Methernitha (CH-3517 Linden bei Bern, Switzerland).

#3. The purchase of an operational Wimshurst electrostatic machine as the basis for further construction alterations and improvements. In 1991 a newly made such machine could be purchased for a relatively low price (i.e. around \$US 30, plus costs of postage if not collected by the buyer) from the factory named "Fabryka Pomocy Naukowych w Nysie" (address: Ul. Słowiańska 43, 48-300 Nysa, Poland). At that time this factory produced one model of the Wimshurst electrostatic machine, named "V5-43" (see Figure 11 in monograph [6/2]), which was supplied for didactic purposes to Physics laboratories in Polish schools. Of course, if ordering the machine from Poland is inconvenient, readers probably

should be able to find and purchase an operational Wimshurst machine in their local area, for example from a second-hand shop or from a local school.

#4. The conversion of the conventional Wimshurst machine just purchased, into an interim device called here "Dr Pajak's model". This device can be defined as an advanced electrostatic machine which has already introduced all the main components and electric circuits required in a telekinetic influenzmaschine. Thus it represents an interim construction which subsequently can be transformed into a telekinetic free energy device. The name for this interim model originates from negotiations between myself and the Polish factory discussed in step #3. During my visit in Poland in 1991 (when I purchased the device shown in Figure 11 of monograph [6/2]) I initiated negotiations aimed at convincing the above-mentioned factory that it should open the production of another model of their electrostatic machine, which could be purchased by hobbyists working on a telekinetic influenzmaschine. During these negotiations a working name of "Dr Pajak's model" (in the Polish language: "Model Dra Pajaka") was given to this new device. It was assumed that the model would incorporate all vital components and technical solutions characteristic for the telekinetic influenzmaschine. The main modifications introduced to "Dr Pajak's model" would depend on such changing the design of this machine, that later it would make possible to simply convert it into a telekinetic free energy device, but simultaneously the changes introduced would not affect its correct operation as an electrostatic machine nor its aesthetic appearance.

Unfortunately, negotiations with the Polish factory were unsuccessful. Therefore, at this stage it is impossible to purchase a ready-made "Dr Pajak's model". But I would still recommend to purchase the conventional model "V5-43" of the Wimshurst machine that this factory produced in 1991 (if this model is still in production), and then convert this conventional model into the device described here as "Dr Pajak's model".

The adaptation of a conventional Wimshurst machine into an interim device suitable for later conversion into a telekinetic influenzmaschine requires the introduction of a number of technical changes. In order to explain them here, I simply described below additional features that "Dr Pajak's model" displays in relation to a conventional model of a Wimshurst electrostatic machine. These features are as follows:

(#4a) Instead of a single electrostatic machine, two separate machines, i.e. frontal and back, are assembled on a common framework and around two common disks. Both these machines are electrically separate (i.e. they use separate couples of the collecting combs, separate wiring, and separate capacitors).

(#4b) The friction of all moving parts is reduced to minimum, e.g. through the introduction of rolling bearings, elimination of sliding electrical connections, the use of a detachable propelling winch shaft, etc.

(#4c) Both plexiglas or glass disks of the machine (preferably around 550 mm in the diameter) are supplied with the number of electrodes dividable by 4 (e.g. 48). The shape of these electrodes corresponds to that used in the Swiss Thesta-Distatica, e.g. they are perforated and look like small ladders.

(#4d) The counter-rotation of both disks is forced by a single belt (B) which simultaneously propels the spindle (Ts) fitted under the disks - see part (d) in Figure LA5. In the later adaptations, the spindle will hold $m=4, 6, \text{ or } 8$ permanent magnets, which during their rotation will co-operate with individual electrodes of the machine and with dynamo-motor (Dm). Therefore the rotational speed of the spindle (Ts) must be so selected, that it allows individual magnets to pass near subsequent electrodes (see the equation (1LA2.3.3) in subsection LA2.3.3). This means that the transmission between the disks and the spindle should be, depending on the number of permanent magnets (m), at the level of $n':n=ds:dd=1:12$ or $1:8$, or $1:6$.

(#4e) If a winch shaft is used to propel the machine during tests of its electrostatic operation, this hand propulsion should be separated from the kinetic link between both disks (dc, dg) and the spindle (Ts) via belt (B). The best solution would be, if a winch propulsion would transmit the motion into a separate pulley attached to the front disk via an

additional (second) detachable belt. So when tests are finished this additional belt could be removed and the machine would still contain all kinetic parts appearing in the telekinetic influenzmaschine.

(#4f) An additional stable framework made of plexiglas, similar to that illustrated in part (e) of Figure LA5, are attached to the machine's basis. This framework allows for the later attachment of all additional electric components required in the telekinetic influenzmaschine, e.g. heads (h), combs (C), telekinetic battery, etc.

(#4g) A single permanent magnet (Mo) interacting with the electrodes of the back disk and cooperating with the magnet in electrode (ho) is attached to the column (t) of the machine's framework.

(#4h) Apart from the bearings and axels, all other components of the machine are made of non-ferromagnetic materials.

After the above changes and adaptations are introduced to a conventional Wimshurst machine, the final device should still maintain its correct operation as three independent electrostatic machines which effectively produce electric currents. When this is achieved, the next step of the conversion of such interim electrostatic machine into a telekinetic influenzmaschine can be undertaken.

#5. Changing "Dr Pajak's model" (just purchased in Poland or obtained from a conventional Wimshurst machine by the introduction of appropriate technical alterations) so that apart from its operation as three electrostatic machines, it will also function as an electrostatic motor. This practically means that the altered front machine, after charging its capacitors by the rotation of disks with a hand transmission, will begin to force the continuous rotation of all kinetic components of the device for a time at least twice as long as that rotation occurring solely because of the inertia. If the above goal is achieved due to an appropriate alterations of the machine's construction, the resultant device can be called a "electrostatic motor" as it reverses the operation of electrostatic machine and becomes an electrostatic motor. The modifying of "Dr Pajak's model" so that it can function as an electrostatic motor requires the implementing of induction heads (h) on each side of disks. These heads (h) should be located similarly as in the telekinetic influenzmaschine and supplemented with appropriate supporting circuits - see Figures LA5 and LA6.

#6. The conversion of the resultant electrostatic motor into a telekinetic free energy device. This requires adding and activation of the telekinetic battery described in the next subsection, as well as the addition of a controller circuit (Dm) and a fine tuning of the whole device. Therefore, the successful completion of this last step demands the employment of the personal inventive capacity, imagination and sensitivity, combined with the solid knowledge of the Telekinetic Effect resulting from the familiarity with the content of this monograph (of course, I am quite happy to assist further in the completion of this ambitious task by providing additional advice and making all my theoretical knowledge available to the developer). Good luck!

In the conclusion of this subsection it is worth stressing that the prospects opened in the case of a success in the completion of such a telekinetic free energy device are almost unlimited, whereas costs are negligible. Therefore, why not to have a go, if someone has all the skills and workshop conditions required!

LA2.4. Telekinetic batteries

When in 1989 I analysed the design and operation of free energy devices that already existed at that time, it hit my eyes that these devices utilised only a small proportion of the Telekinetic Effect that they produced. Furthermore, they utilised this effect mainly through the least-effective centrifugal acceleration caused by spinning of sources of magnetic field. Thus, soon after I learned the operation of the Telekinetic Effect, I started to believe that there is a possibility of developing a device, that would significantly increase the output and efficiency of

telekinetic generation of electricity. This device would utilise the much more effective manner of accelerating magnetic field, which, however, was not known so deeply as the centrifugal acceleration does. This manner depends on the formation of an impulsive (pulsating) magnetic field. Such a pulsating field must also cause the release of the Telekinetic Effect, if only the pulsations are deprived of symmetry according to appropriately selected curve. (I.e. if these pulsations are asymmetrical.) The additional benefit would be that the operation of such device is not requiring any moving parts. In turn the complete lack of moving parts will significantly simplify the design of it. Furthermore, the lack of moving parts will also prevent a mechanical wear and tear that results from cooperation of movable parts. Such an utilisation of magnetic pulsations should additionally increase the efficiency of work of this device, as it eliminates completely mechanical friction.

After I completed the technical synthesis along the above line of thinking, in 1989 I invented and worked out, while in 1990 I published in the first edition of my monographs [6] and [6a], the idea of completely new free energy devices. These devices utilise pulsating magnetic field for releasing the Telekinetic Effect. I call them “telekinetic batteries” or “telekinetic cells”. (A condensed history of their invention I am describing in subsections LA2.4.3 and W4.) Telekinetic batteries (or telekinetic cells) do not have any moving parts. Their operation depends on replacing mechanic motion with electro-magnetic motion (i.e. the Telekinetic Effect is released in them through oscillations of magnetic fields and electric currents). Thus the design of telekinetic batteries is based on the cross between an inductor, an oscillatory circuit, and an autotransformer, not on the mechanism of operation of present motor or generator.

In times when I invented and published the idea of my telekinetic batteries, i.e. in 1989, I did not know any other researcher in the world, who would carry out research agreeable with my line of thinking. But with the elapse of time I managed to identify a couple of such researchers. However, my analyses of their devices revealed, that these researchers were very far from a clear understanding how such devices really supposed to work, and from understanding what principles and phenomena supposed to be employed in them. No wonder that prototypes of these researchers were unable to work.

In the effect of various analyses and research, and also in the effect of a whole sequence of strange “coincidental events” which bordered with miracles and which clearly tried to assist me through a correct directing my creative searches, with the elapse of time I worked out the exact design and operation of telekinetic batteries of my invention. I am going to present this design and operation in the subsection that follows. In this description I am going to present the hypothetical battery, the design and operation of which directly stems from my knowledge of the Telekinetic Effect, from directions provided by the Concept of Dipolar Gravity, and also from technical analyses of devices other than my telekinetic battery.

LA2.4.1. Design and operation of telekinetic batteries

The telekinetic battery of my own invention is in fact the most simple free energy device that one possibly can build. So it is also the most easy for the construction and the most inexpensive for the production. Simultaneously it is the most effective one out of all free energy devices. It can be constructed as a “stand alone” energy generating device, e.g. taking a form of a small generator to be used in literally every flat. It can also be build in structure of other devices to supply them with free electrical energy. Therefore my personal recommendation is, that all researchers who work on free energy devices should concentrate their attention on constructing such a battery.

Main components and the general design of the telekinetic battery of my invention, are shown in **Figure LA7**. This device is composed of several functional components. After an appropriate mutual connection these are forming the described previously cross between an inductor, an oscillatory circuit, and an autotransformer - means are forming a complete

telekinetic battery. Let us now list and explain subsequent functional components of my telekinetic battery. Here they are:

#1. Pulser (D) and (Q). The major function of a pulser is to induce a continuous sequence of electrical pulses. These pulses are then forwarded to an entry of a telekinetic battery, thus initiating the oscillations of the entire battery. Thus the operation of a pulser depends on continuous generating of a pulsating electrical signal of a strictly defined and constant frequency. This signal initiates then the operation of the whole battery and prevents the oscillations of this battery from a gradual diminishing. In the function of just such a pulser any electrical device can be used that utilises some sort of natural phenomena which is able to generate a continuous stream of electrical signals of a constant frequency. For example a perfect pulser is constituted by $e = 48$ electrodes from the frontal disk (dc) of the telekinetic influenzmaschine described earlier, that interact with the head (ho), if the disk (dc) is spinning steadily with the rotational velocity of $n=62.6$ RPM. A pulser can also be formed by piezoelectricity excited by telepathic vibrations - as this is described in subsection H7.1, by geo-electricity, trybo-electricity, electricity from electrochemical phenomena, etc. But most probably the best for telekinetic batteries is going to be the use of a pulser that is utilising telepathic vibrations of the environment. Such a pulser would be composed of two parts, namely a quartz **generator of pulses (Q)**, and a telepathic **resonance chamber (D)**. In this case, the quartz generator of vibrations is to produce a consistent stream of electrical oscillations with a strictly defined frequency that harmonises with the working frequency of the entire battery. In turn the resonance chamber is to select from the unlimited numbers of various vibrations, and subsequent amplifying, these telepathic vibrations the frequency of which coincides with the own frequency of the generator of pulses, and with the working frequency of the entire battery. The operation of these two components, means the generator of pulses and the resonance chamber, is complementing each other, in the final effect generating and forwarding to the remaining circuits of the telekinetic battery an initiating sequence of electrical impulses with a strictly defined frequency. In the example of the telekinetic battery presented in Figure LA7, the "resonance chamber" is any space (D), which causes the resonance of telepathic waves. In turn the "generator of pulses" is a piezoelectric generator (Q) – e.g. a quartz crystal. This generator converts the standing telepathic wave that is formed by a resonance chamber, into a pulsating electrical signal of the same frequency. As this is described in subsection H7.1, telepathic vibrations are spreading constantly through the counter-world, similarly like various sounds are propagating through our world. So if we position appropriately selected quartz crystal in the focal point of a resonance chamber that concentrates telepathic vibrations on this crystal, then the crystal is subjected to a telekinetic compression and decompression in the tact of these telepathic vibrations. Thus it must generate a non-diminishing electrical oscillations that are produced continually through any desired length of time.

Any chamber that focuses and resonates telepathic vibrations can be used for a resonance chamber. (Most probably the best such a chamber turns out to be an Egyptian pyramid of the height that is equal to the side dimension of the base.) Because telepathic vibrations so-far remained unknown to our orthodox science, in the literature they are most frequently described under different names, e.g. so-called "pyramid effect", or "**pyramid energy**" (these vibrations are called so because their focusing in pyramids causes the commonly known consequences, such as mummification, sharpening of razors, etc.), "orgone", or "tachions". In the book [1LA2.4] by Serge V. King, Ph.D., "Pyramid Energy Handbook", ISBN 0-446-92029-0, pages 34 and 38, it is stated that the "pyramid energy", apart from the four-side pyramids which turn out to be the best for this purpose, can be also focused by long metal tubes, as well as three-sided pyramids (tetrahedrons). In case of the telekinetic battery shown in Figure LA7, as such a resonance chamber any geometrical form known from the ability to resonate and to focus telepathic vibrations can be used. For example it can be a pyramid explained in subsection N2 with four aluminum disks on the side walls. Of course, the same function can also be performed by many other forms. Therefore in Figure LA7 it is

symbolized with a shape of an aluminum sphere with a single hole through which telepathic waves are entering. In the focal point of this chamber a piezoelectric generator of pulses must be placed (e.g. a quartz crystal “Q”), on which the telepathic vibrations are to be focused.

At this point it is worth to notice the similarity of telepathic waves to acoustic waves explained in subsection H7.1. In turn from the design of musical instruments we know jolly well, that not every shape is going to produce an effective resonance chamber (this is the reason why the sound of violins produced by the Italian master Antonio Stradivarius (1644-1737) no-one is able to duplicate). For example, for a long time it is established that chambers shaped into cubes are unable to form the “effect of pyramid” (although elongated square rods are able to form it).

The pulser in the telekinetic battery performs a function similar to clocks in present computers. It provides a sequence of pulsations on which the operation of the entire device is based. It also determines the frequency of this vibratory sequence, means the base frequency of the operation of the entire battery. The significance of this frequency can be compared to the significance of the pulsations in the operations of present computers. Furthermore, electrical pulsations of the quartz (Q) supply also the initiating current signals from which the deformation of the pulsation curves are introduced by field-deforming inductors (I_1) and (I_2).

#2. Field-deforming inductors (I_1) and (I_2). These are most vital components of every telekinetic battery. This is because inside of them the telekinetic generation of electricity is carried out. They carry out this generation through deforming curves of subsequent electrical pulses supplied by the pulser, that flow through them. In turn, such deformed curves cause periodical acceleration and deceleration of the motion of electrons, means they actually cause the release of the Telekinetic Effect. In every telekinetic battery two such field-deforming inductors must be present, means a separate inductor (I_1) which works on the ascending slope of the curve of pulsation, and a separate inductor (I_2) which works on the descending slope of the same curve of pulsation. The key for the operation of these two is the fact, that the **field-deforming inductors are wound up on surface of permanent magnets**. The result of this winding is, that pulsating electricity supplied by the pulser and flowing through these inductors, is deformed in them in a manner that creates a one-directional Telekinetic Effect (see also descriptions from subsections LA2.2 and LA2.3). This deformation in turn causes, that the electric current that flows through each coil of the inductor is inducing telekinetically in next coils of the same inductor a current that is stronger than itself. In the consequence of such an operation, inductors telekinetically add additional energy to electrical pulses that initially flow through them. So if they are placed in a circuit of the resonator, they are to increasingly generate in this resonator the self-sustained electrical oscillations. So they are going to generate telekinetically the increasingly larger electric current. It is worth to notice, that one of these inductors is producing the Telekinetic Effect that generates an additional electric current during the ascending phase of oscillations of a given resonator, while the second one – during the descending phase of these oscillations. Depending on the direction of winding of coils of both inductors in relationship to the polarity of magnets, and also depending on the manner of their connecting to the circuits of the resonator, the ascending or descending inductor can be either (I_1) or (I_2). If there is an error in connecting or in winding of these inductors, it is possible that both of them are going to work simultaneously as either ascending or descending, thus mutually cancelling effects of their operation.

The key to the operation of field-deforming inductors (I_1) and (I_2) is the fact that each one of them is wound in an opposite direction – means one with the clockwise coils, while the other one with the counter-clockwise coils. The effect of such winding is that the oscillating magnetic field formed by the electric current that cyclically flows forth and back through these inductors, is deformed in an imbalanced manner. The reason for this imbalance is the model of electrons as whirls of counter-matter, described in subsection H5.1 of this monograph and also in subsection L5.1 of monograph [8]. These electrons always direct their axes of spinning exactly towards the direction of their motion. In turn, because of this their orientation, these electrons (or whirls of counter-matter) that flow in one direction through a coil that is wound

clockwise, are interacting with the field of permanent magnets in exactly opposite manner as electrons flowing through a coil that is wended counter-clockwise. The outcome is such, that depending on the direction of mutual flows of counter-matter through a given permanent magnet and in whirls of electrons, the current in a coil is either reinforced or weakened. This in turn causes that curves of flow of electric currents in both inductors are subjected to one side deformation, means are imbalanced. In turn this unbalancing causes that these inductors gain ability to form a Telekinetic Effect that works in one particular direction. (For details see also descriptions from subsection LA2.2.) An attribute of this imbalanced effect is, that it forces motion of electrons of a conductor in one direction. The outcome is such, that the Telekinetic Effect is causing a cumulative increase of the power of electric current, allowing both inductors to generate sufficient amount of electrical energy to satisfy the use of energy by the entire telekinetic battery, and by the user of this battery. Of course, because the oscillating currents flow through these inductors in both directions, it is desirable that the telekinetic thrust is also formed in both these directions. Therefore it is necessary to use two such inductors, namely (I_1) and (I_2), each one of which is wended in an opposite direction, so that each one of them is producing the Telekinetic Effect in a different halves of the oscillation cycle.

A perfect demonstration of the outcome of the operation of such field-deforming inductors provide electronic guitars. These guitars use permanent magnets with coils wound around them (means just use inductors described here) for the enrichment of sounds that they produce. As it turns out, after the flow through these inductors, the sound of given electronic guitars assumes completely different tone. This in turn means, that electrical signals that flow through such inductors in fact do experience asymmetrical deformations.

#3. Resonator (R). A resonator is simply an oscillatory circuit that is incorporated into the structure of a telekinetic battery. In reality it is a “beating heart” of this battery. It performs several vital functions. The most important out of these functions, is the dynamic summation of small portions of energy. This function depends on adding together small portions of energy and on a gradual binding (or accumulating) this energy in dynamic electrical oscillations.

In order to explain here more extensively what this dynamic summation of energy generated by a given telekinetic battery is all about, we need to recall from previous descriptions, that both inductors (I_1) and (I_2) generate electrical energy in the form of a long sequence of small increments. So the battery must have some sort of a component, which is going to intercept these small portions of energy, add these portions together, and then make them available to the user as a summarised flow of electrical energy. The role of just such a summarizing component is fulfilled by oscillatory circuits. In order to illustrate this ability of an oscillatory motion to intercept and to accumulate small portions of energy generated in the battery by inductors (I_1) and (I_2), let us use an example of lifting a child high up into the air. If this lifting is to be done with the use of continuous motion, the whole energy required for it must be supplied at a single go. Thus, in order to lift such a child with a continuous motion, a real powerful athlete is required. But if we use an oscillatory motion, for example by putting this child on a swing, then the same effect can be obtained gradually. Therefore, even someone as weak as other child, is able to supply the required small portions of energy to that swing. This is because the oscillatory motion allows the swing to intercept energy slowly and gradually, in small portions, throughout a longer period of time. So if someone pushes the swing only slightly, but continually, the final effect will also be that the swing will go high up into the air. So this child on a swing adds and accumulates dynamically in its oscillations the energy of subsequent pushes. In the result, as the time elapses, the swing will have increasingly larger total energy. It will be able to supply later this total energy to the user in a single portion, e.g. during an accidental hitting someone who incautiously comes too close to the swing. In a manner very similar like this child on a swing, also the resonator works in the telekinetic battery. It also dynamically adds and accumulates small portions of energy that are continually supplied to it by inductors (I_1) and (I_2).

Independently from a dynamic summation of energy, the resonator (R) performs also several further functions. These other functions are to reassure that the battery works without

interruptions, and also to form pulsating electric current which can later be modified by other components of the battery (e.g. by the field-deforming inductors I_1 and I_2).

To decrease the volume of this monograph, I am omitting the presentation of the deductions that allowed me to formulate requirements that must be met by resonators of the telekinetic batteries. (I intend to present these deductions in a next edition of monograph from series [6].) However, our understanding of these batteries will be enhanced, if I explain what these requirements actually are. The key to our understanding of requirements imposed on these resonators, is a main property of telekinetic batteries which I call with the use of the technical term "**reciprocation**", although it would be expressed even better with such common terms as "returning back", "giving back", or "self-instigating its own oscillations". **A "reciprocal" oscillatory circuit is a circuit which is capable to self-initiate and self maintain regular oscillations each time it is supplied with any energy at a required level, even if parameters of this energy each time are different.** To put it in another words, the reason why a reciprocal oscillatory circuit is perfect for constituting the resonator for a telekinetic battery, is to make this resonator work each time it is supplied with any possible energy impulses. Such resonator should initiate oscillations no matter how small and chaotic these impulses of energy would be, and no matter what their parameters would be. Such a reciprocal oscillatory circuit has always the capability to transform these chaotic impulses into regular AC electricity oscillations.

In order for any oscillatory circuit to become reciprocal, it needs to meet the following conditions: **(1)** it must create oscillations which are characterised by at least two degrees of freedom (although the more degrees of freedom, the more reciprocal a given circuit is), **(2)** it contains inside a "reversible component" which supplies it with inertia, and **(3)** it is capable to self-initiate its oscillations from zero, if the energy input is provided (i.e. it starts to oscillate all by itself, each time it receives some energy input). Let us now discuss separately each of these conditions.

We can say that an oscillatory circuit is having **two degrees of freedom**, if in this circuit two different types of oscillations can coexist at the same time. In order to provide some examples, a swing with metal arms and a ball bearing, both have only one degree of freedom, as both can only oscillate in one manner, namely swinging forth and back. But a curved blade of a stiff grass has more then one degree of freedom, as apart from swinging forth and back, it can also wobble sideways. Therefore a blade of grass is more "reciprocal" then a swing, as for example chaotic blows of wind which are NOT able to put swing into oscillations, are making such a grass uniformly buzzing (I hope that the reader remembers observing in childhood a blade of stiff grass buzzing uniformly in a wind). Two degrees of freedom would also have an arm attached to sit of a swing and thus swinging in two manners (i.e. having its own oscillations, and also oscillating together with the entire swing).

In turn the **reversible component**, is a single part of a given "reciprocal" circuit, which has a capability of simultaneous working in both directions. Namely it can transform the energy of oscillations into energy of motion, and it can also transform energy of motion into energy of oscillations. Both these transformations must be carried out with the same ease, without a need for any adaptation or switching. A best example of a reversible component is a spring in an old mechanical clock, which can transform the winding motion into energy that propels this clock, but also can transform the energy which is frozen in the coils into a slow motion of unwinding. Other examples of reversible components are: some types of speakers which can operate as microphones, microphones which can work as speakers, electric capacitors connected to inductive coils, generators of electricity which without any adaptation can work as electric motors, quartz crystals capable of executing two-directional piezoelectric effect (i.e. allowing the physical displacement to be converted into electrical impulse, or electrical impulse to be converted into physical displacement), hydraulic pumps which can also work as hydraulic motors, thermo-cells which simultaneously can work as electric heaters, and wheels in old locomotives. These old locomotive wheels, because they are joined with pistons via connecting rods, are causing that when pistons are moving, the wheels transform the

energy of pistons' oscillations into the motion of a whole train. In turn when pistons are motionless (i.e. after they reach the so-called "dead points" in cylinders) the wheels are transforming the motion of the whole train into the oscillations of pistons. The wheels of old locomotives are the best example of what is the purpose of reversible components in all reciprocal systems. These components are necessary because they provide an inertia to the systems. In turn this inertia converts the chaotic energy impulses that are supplied to the reciprocal systems, into a series of orderly oscillations.

Finally the ability of oscillatory systems to **self-initiate** the oscillations from zero, is the property of reciprocal oscillating systems which causes that they are able to start oscillating entirely by themselves, each time some external energy is supplied to them, even if at the moment of starting they are totally motionless. To give here some examples, pistons in the combustion engines used in our cars are not able to self-initiate their oscillations from zero. This is why we need starters in our cars. Thus, the ability of combustion engines to self initiate their oscillations is zero (null, or none). So, oscillatory circuits similar to such engines would NOT be able to work as telekinetic batteries. But pistons in old railway steam engines were able to initiate their oscillations from zero. This is why old steam engines never did have starters like our present cars do, and still they initiated their run each time the steam was supplied to their pistons.

The old railway steam engines provide an excellent clue as how the self-initiation attribute can be achieved in all reciprocal oscillatory systems. As it turns out, every oscillatory system is having the so-called "dead points", or "dead locks", namely phases of their oscillatory motion in which the entire system tends to stop and is unable to start again. In case of single-piston steam engines, they have two "dead locks" located in the turning points when the piston finishes motion in one direction, and starts to move in an opposite direction (but note that an ordinary swing has such dead points located differently - namely in the middle of strokes). Therefore, if one builds a locomotive which has only a single piston, and if somehow it would happen that such a locomotive stops in an unfortunate manner that the piston is located in one of these dead points, then the locomotive would not be able to start again. This is reason why each old steam locomotive used to have two pistons, one on each side, and both of them were joined via connecting rods with the same pair of locomotive wheels. The key design point was, that these two pistons were always working with mutual phase shift equal to half of their stroke (i.e. to 90°). Therefore, if one piston was just in a dead point, the other was right in the centre of the self-initiating capability, and vice versa. In this way locomotives with two pistons, which (the pistons) are shifted in phase by 90° and mutually joined in parallel via two connecting rods and a pair of wheels, are the oldest example of a fully "reciprocal" technological system that was ever invented on Earth. Even today these old steam locomotives provide the best illustration of the principles, by utilising of which the "reciprocal" systems can be build. For example, they indicate that in order to increase the ability of these systems to self-initiate their oscillations, all what it takes is to use more then one (the more the better) oscillatory components, such as pistons in these old locomotives, and then join these components together via a parallel connection in a manner which guarantees that they work with significant phase shifts. Our present combustion engines from today motor-vehicles are proofs that this principle works in practice. This is because for example car engines which have more then one piston linked in parallel via a crankshaft, are much easier to start, than let say one-piston motorbike engines.

Another mechanical example of the implementation of the principle of reciprocal operation are motors which convert constant temperature difference into oscillatory motion (which in turn is converted into a rotary motion). Two such motors were invented. These are the Stirling motor, and the Ericsson motor. The Stirling motor was invented in years 1816 to 1840 by a Scottish pastor, Robert Stirling. In turn the Ericsson motor was invented in 1833 by an American inventor of the Swedish origin, John Ericsson. In turn an example of an electronic device which displays the reciprocal operation is the so-called "crystal oscillator" sometimes also called the "quartz oscillator". The most common application of this oscillator is in quartz

watches. If to such an oscillator a constant supply of energy is attached, then it converts a constant electricity onto a stream of electrical oscillations, which in watches is a measure of the elapse of time.

To summarise the above, in order to obtain an oscillatory circuit which is able to work as a resonator in a telekinetic battery, we need to design a "reciprocal" electronic circuit which: **(1)** is able to sustain oscillations that have more than one degree of freedom - e.g. that are composed of a multitude of vibrations, **(2)** includes a reversible component - such as a quartz crystal producing a piezoelectric effect, and **(3)** which allows for a self-initiation from zero – means which contains a high number of oscillatory components that are connected together in parallel with a mutual phase shift - such as numerous salt crystals connected together via mercury. As it turns out, the circuit used in the telekinetic pyramid which is described in subsection N2.4 and illustrated in Figure N5, fulfils all these requirements. How it is accomplished I am going to briefly describe in subsection N2.4.

#4. Tube, or reciprocator (T). This is a device very unique to the telekinetic battery. (It is also present in the telekinetic influenzmaschine, in which a telekinetic battery represents the most important component – see Figures LA4 to LA6) It performs a whole range of various functions, becoming one of the most vital components of the battery. The most irreplaceable function performed by the tube (T) is that it provides the battery with the attribute of "reciprocation", which I already explained during the presentation of the resonator (R). The second important function is to supply the battery with the electrical inertia. Further function of the tube (T) depends on imposing an order and correct direction on the electrical current that flows through the battery. This order and direction are accomplished due to the action of this tube as a flexible rectifier. In turn it becomes a flexible rectifier in the result of passing through the central axis of it an orderly magnetic field that originates from a loose spiral of the current resistant wire that is wined around the surface. Another function of the tube depends on piling the voltage of the battery, until this voltage grows to the required level. It also disposes the excess of electricity. Thus in the telekinetic battery such a tube (T) is a multitask component that is capable of operating in many different ways. In turn all these operations of the tube in the final effect produce numerous desirable phenomena which allow the battery to generate electrical charges of the required power.

The most vital function of the tube (T), that requires here a special highlighting, is to supply the telekinetic battery with the extremely important attribute of "**reciprocation**" described earlier. This attribute results from an unique design and operation of the tube, which adds further degrees of freedom to the oscillations of the current in the telekinetic battery.

The second vital function of the tube (T), is to provide the resonator with the required electrical inertia. This function is based on the glowing (excited) ions of salt and mercury. As I am explaining in my publications for a long time (e.g. see subsection D4 in monograph [5/3]) the telekinetic battery described in this subsection, the oscillatory chamber described in chapter C, the telepathic pyramid described in subsection N2, and also partially the telekinetic influenzmaschine described in subsection LA2.3.3, all these belong to a new group of devices which I call "**magnetic resonators**". These magnetic resonators employ the principle of operation that is a mirror reflection to "electrical oscillatory circuits" used for a long time in our electronic devices and in our telecommunication. Similarly like electrical oscillatory circuits must contain at least two components, namely electrical capacitance "C" and magnetic inertia (inductance) "L", also magnetic resonators must contain at least two components in order to work, namely an electrical inertia "J" and the magnetic capacitance "P". Of course, in addition to these two "mirrored" components, both groups of devices, means magnetic resonators and electrical oscillatory circuits, will also be including electrical resistance "R". The glowing (excited) ions of salt and mercury from the tube (T), are providing the magnetic resonator discussed in this subsection with the required electrical inertia "J". In turn the magnetic capacitance "P" is provided to it by the inductors (I_1) and (I_2) of a special design.

Theoretically speaking, in function of the tube (T) discussed here, other purposely build devices could also be used in a telekinetic battery. All what is needed, is that such other

devices would perform all functions that are imposed on this tube (T). So in the future most probably empty inside telekinetic batteries are going to be build, similar to the battery described in subsection T4, in which function of the tube (T) is performed by some semiconductor laminate components. However, if we supply the battery with a tube that is based on the mixture of salt and mercury and which produces fluorescent light – as this is described below, then the functions imposed on this tube are accomplished in a simplest possible manner.

#5. Capacitor (C). It accumulates the electrical energy that is generated by a given telekinetic battery. In the telekinetic influenzmaschine described in subsection LA2.3.3, the function of this capacitor C is performed by separate capacitors in Figure LA6 marked as (L-) and (L+).

#6. Autotransformer (A). It adjusts the voltage of the electricity generated by a given telekinetic battery to the requirements of the users, and supplies this electricity to the output terminal (W).

* * *

Each component of the telekinetic battery described above is so simple, that it can be manufactured almost by the majority of interested hobbyists. The aluminium resonance chamber (D) may be manufactured (or purchased) in any shape known to generate the "pyramid energy" explained before. The function of this chamber depends on focusing telepathic vibrations on the quartz crystal (Q). So in the operational sense this resonance chamber is a cross between an optical "black hole" and an acoustic lens. Wirings of the autotransformer or transformer (A) may be formed from ordinary spirals of a copper wire wined around transformer core. Each one out of two inductors (I_1) and (I_2) is containing a single permanent magnet with isolated wire wined on this magnet. The tube (T) is a small glass ampoule filled up half by ordinary kitchen salt, half by mercury, and kept under vacuum. Into this mixture of salt and mercury two electrodes must be inserted, while along the external surface of this ampoule a coil from a resistant wire is wined (i.e. made of the wire used in electric heaters). The piezoelectric crystal (Q) is an ordinary quartz crystal used e.g. in electronics. Only that the frequency of this crystal must be appropriately selected, as this is described below. So it could be purchased easily in shops with electronic components.

The operation of the telekinetic battery of my invention, described very briefly, is as follows - see the diagram from Figure LA7. Casual telepathic vibrations, means a telepathic noise described in subsection H7.1, are entering the resonance chamber, where they are deflected and focused on the quartz crystal (Q). Because frequency of these telepathic vibrations coincides with the own frequency of the crystal (Q), they instigate the crystal (Q) into the state of resonance. Thus the crystal (Q) vibrates violently, similarly as a membrane from our world would vibrate if acoustic waves are focused on it. The piezoelectric effect which this crystal (Q) is able to form, transforms these violent vibrations of the crystal (Q), into series of electric pulses. So the crystal (Q) works in the battery as a pulser, which supplies the battery with a constant stream of electric pulses. The resonator (R) utilises the special capability called here the "reciprocation", which is provided by the tube (T), to turn these series of pulses into regular electric oscillations. The current of these oscillations flows in an oscillating manner forth and back through both inductors (I_1) and (I_2). In normal circumstances the internal electrical resistance of this circuit would cause that the current's flow would never exceed the value detectable by our instruments. But in case of the telekinetic battery, it flows through inductors (I_1) and (I_2), the unique property of which is that they produce a non-balanced Telekinetic Effect, which increases the flow of current. This non-balanced Telekinetic Effect one could liken to a series of slight pushes that someone adds in correct moments to an already moving swing, thus gradually increasing its kinetic energy. In the final effect, the telekinetic vibrations that are initiated by the quartz pulser (Q) and transformed by this quartz into electric pulses, are then developed and uniformed by the resonator (R), increased and energetised by inductors (I_1) and (I_2), to produce a powerful electric current which supplies the whole battery and the outside consumer in the required electrical energy. This electrical

energy can be utilised for industrial purposes, for supplying in free energy various external devices, etc.

The result of operation of the telekinetic battery described here, is that it generates an abundance of alternating current (AC). So it operates as an effective AC battery. After an appropriate technical tuning in (to make it generate electricity at 50 Hz and 220 V), and after appropriate increase of the produced power, such a battery can be utilised for the supply of any possible consumers in electricity, for example households, technical appliances, heaters, means of transportation (e.g. cars), etc. From the data available at present, it can be deduced that a telekinetic battery of a dimensions of around a half of meter, should supply electricity that would suffice for complete satisfying energy consumption by a family household, or to satisfy energy consumption of a small car.

The above deductions should be complemented with the information, that the operation of circuitry of the telekinetic battery discussed here imposes several operational requirements on this battery. The most vital out of these requirements is that frequencies of own oscillations of all components of this battery must fulfil the requirement of harmonics. This means, that for example the own frequency of circuits of the resonator (R) must be harmonic to the frequency of the quartz crystal (Q). (Note that "harmonic" means either equal to, or an even multiple of.) The frequency of quartz (Q) should also harmonise with own frequency of the standing telepathic wave formed inside of the resonance chamber (D). Finally frequency and parameters of glowing of the tube (T) must coincide with the frequency and parameters of the remaining circuits of the battery. Another vital operational requirement of this battery is that the level of telekinetic reinforcement of the inductors (I_1) and (I_2) must exceed the coefficient of dumping in circuitry of this battery. (This telekinetic reinforcement is to depend on the number of coils winded on these inductors, on the manner these coils are winded, and on the strengths of magnets used for these inductors.) Also the resonator (R) must fulfil the requirement of being "reciprocal". (Note that this requirement includes having at least two degrees of freedom, including a reversible component, and being able to self-initiate.) Finally the resonance chamber (D) must have a shape which allows it to form a standing telepathic wave – means it must generate the so-called "pyramid energy" described in [1LA2.4]. It also must concentrate this telepathic wave on the piezoelectric crystal of the same own frequency as this wave.

The theoretical analysis of the telekinetic battery reveals that this battery is going to display various advantages that are much more desirable than these from other telekinetic power-stations described in this chapter. For example, it is going to be deprived almost all drawbacks of these devices. It is going to produce alternating current (AC) which is easy to become transformed and ready for consumption in the currently existing electrical appliances. It is going to be easy for controlling. It is not going to wear nor tear during the exploitation. It is relatively easy and cheap for production. Thus, out of all types of telekinetic free energy devices, it is the most suitable for commercial applications. For these reasons, I highly recommend to readers with the inventive and developmental skills to initiate work on constructing it. The most effective in my opinion procedure of the development of this battery is presented in subsection LA2.4.2.

It is worth to add here, that the device described in subsection N2 also contains a built telekinetic battery very similar to the one described here (for the description of an example of this battery in operation see subsection T4).

LA2.4.2. Recommended procedure for constructing a telekinetic battery

These very special people, who are gifted towards building various devices - would these be electronic, electrical, or simply mechanical, who have inquisitive minds, creativity of inventors, and inclinations for experimenting, who have enough courage to not be afraid that the participation in the battery's completion may endanger their lives introducing a risk of alien

assassination - as explained in subsections W4 and VB4.5.1, who would like to add their own contribution to an enormous leap forward for the whole of our civilisation, and also who do not mind that 10% from the obviously huge profits that the completion of this device one day may bring to the developer are to be contributed towards the developmental research on similar avant-garde devices - as described in subsection AB2, are invited and encouraged to contribute their efforts to the completion of this special device. Below the completion procedure is described, which in my own opinion holds the highest chance of the final success. This procedure is combined from the sequence of steps, through many of which I went myself in my efforts to-date to make this battery happen. This sequence needs later to be repeated as many times as it takes (hence the name for this procedure: "iteration method", or "method of small steps"). Each such repetition is to solve a single problem and to create the bank of practical experience which with the elapse of time must translate into the final success.

The iteration method can be arranged and completed according to several different scenarios (by experts usually called "developmental models"). The simplest scenario could be called "component-after-component". It depends on subdividing the final device (i.e. the telekinetic battery) into individual components or parts, and then preparing one component after the other, until the whole battery is ready. This method is simplest amongst all possible approaches to the completion of the telekinetic battery. It is described in details in subsection N2.3. Here I am presenting another method, which usually is described as the "waterfall model". It depends on gradual developing the entire battery, through subsequent repetition of the development procedure. Here are steps to be taken during the completion of this procedure.

#1. Learning the design and operation of the telekinetic battery. The aim of this step is to learn and to understand what are basic components of this battery, what are purposes and operations of these components, and what are conditions that these components must fulfil. In order to accomplish this step, we need to: (a) read especially thoroughly the parts of this monograph, and other my monographs, which contain any information about the design and operation of telekinetic batteries, about phenomena that are utilised or induced in these batteries, about prospects of utilization of these devices, etc., and (b) to produce for ourselves a written specification of components that constitute our battery, together with operational and construction requirements that each of these components must fulfil.

#2. Adopting the electrical diagram of the battery to our own circumstances. The aim of this step is to obtain a design of the battery, which we can complete ourselves, and which in a possibly best manner reflects the electrical and electromagnetic relationships that exist between subsequent components of the telekinetic battery. In this way we also realize to ourselves various requirements imposed on these components, which we previously were not aware of. In order to complete this step, it is desirable to prepare, on the basis of the electrical diagram from Figure LA7, our own electrical diagram of this battery. The main purpose of this our own electrical diagram is to obtain a circuit which we could build ourselves, and which (1) has an oscillatory circuit with two degrees of freedom, (2) contains a reversible component, and (3) it displays a guaranteed attribute of "reciprocation". This circuit would be supplied into impulses from a pulser of our own design, and would pass the electricity into a transformer or autotransformer. On this our own diagram we should mark all points of electrical connections, exact directions of flows, directions of winding, etc.

#3. Analysing and confirming on our own diagram the operation of this battery. The aim of this step is to obtain the highest possible at our level of experiments, understanding of operation of the telekinetic battery that we are completing. In order to implement this step, it is desirable to analyse carefully our own diagram obtained in the result of step #2, and to verify whether this diagram is going to implement the principle of operation of the telekinetic battery described in this chapter. During checking this our own diagram it would be desirable to: (1) distinguish subsequent circuits which are composed into our telekinetic battery, (2) qualify each of these circuits from the functional point of view (e.g. the

pulser circuit, the oscillatory circuit of the resonator, the circuit of the tube, the primary circuit of the transformer, etc.), (3) determining the directions of current flows, and also the character and parameters of the current (e.g. voltage, amperage, curves of changes in time, frequencies, etc.) in subsequent circuits. Conditionally we could also (4) describe mathematically the operational conditions for each of these circuits, and (5) mathematically describe the entire battery.

Notice that such mathematical description of the battery is easy, when we begin it from the exit (i.e. from the output terminal). Namely we know that at the exit it must produce an electric current of, let say 200 Volt, 50 Hz, and e.g. 1 kW. Thus going backwards we are able to determine the inductances, capacitances, resistances, etc., of subsequent components, finishing on the quartz crystal and its frequency.

#4. Developing operational conditions of our battery. The aim of this step is to reason about operational conditions that must be fulfilled by the battery to make it work in the electrical sense, and to gather that way the information about parameters of work of subsequent components. In order to implement this step it is desirable to analyse the mathematical or at least a functional description of subsequent circuits and the entire battery (produced in step #3), and then to draw useful conclusions regarding the desired relationships between parameters of work and design relationships of main components (means between frequencies, capacitances, inductances, etc.).

#5. Purchase or making of components that fulfil the conditions deduced by us. The goal of this step is to construct ourselves, or to purchase, components the design and parameters of work of which would fulfil the set of conditions deduced during the completion of the step #4. It is worth to stress, that there are available videos on the Thesta-Distatica (described in subsection LA2.3.1) which perfectly illustrate in action two most vital components of telekinetic batteries, telepathisers, and telekinetic infuenzmaschinen, namely tube (T) and inductors (I_1) and (I_2) – visible also on photo from Figure LA4. By observing these components on such videos, the reader may gain a better understanding of the manner in which they should be made.

The most vital component of telekinetic batteries is the tube (T) that displays an entire complex of attributes connected with the so-called "reciprocity" and explained in details in subsection LA2.4.1. Both, the operation of the telekinetic battery, as well as parameters of work of this device (e.g. the efficiency) are to depend on the quality of this tube. According to what about this tube is explained in subsection N2.6.3, it needs to be made from a mixture of salt and mercury inserted into an ampoule of quartz glass and supplied with electrodes on both ends. Salt must be carefully selected, as it must be composed of large, even, and well shaped crystals that are to produce an efficient piezoelectric effect. Furthermore, the purity of salt crystals must be sufficient to reassure the even contact with mercury. Before inserting into the ampoule, salt must be well dried out, e.g. through heating it in an oven, because even a trace addition of water spoils the properties of it. The mutual proportion of the volume of salt and mercury must be carefully selected, because the tube filled with this mixture in a static state must be a kind of a resistor (not a conductor), although it must also conduct electricity (i.e. it must not be a resistor with an infinitely large resistance). In fact, as this stems from analyses of the attributes of "reciprocity" which are to be supplied by this tube, the higher is the static resistance and the more stable this resistance is, the better is work of this tube (means the resistance of this tube should change only minimally during moving or shaking it). In turn this static resistance is dependent on the ratio of salt to mercury, and also on the quality of contact of electrodes and mercury. After salt and mercury are inserted to the tube and tightly packed in there, the air should be pumped out from the tube to the level of around 50 to 300 [mTorr], while the tube itself should be sealed. Then on the external surface of the tube even coils of resistant wire should be winded, which are to create magnetic field that runs along the axis of this tube. These coils should have a static resistance much higher than the tube itself. Moreover, vital probably is going to be the ratio of the diameter of the tube to the number of coils winded on it (this decides on the penetration of the tube by magnetic field).

Another vital components of the battery are deflecting inductors "I₁" and "I₂", means coils wound on permanent magnets of preferably rounded cross section. In these inductors important is their inductivity and coefficient of deformation of current pulses. The inductivity depends on the number of coils, regular winding of these coils, and on packing of subsequent coils. In turn the coefficient of deformation of the current pulses depends on the force of both magnets on which these inductors are wound up.

#6. Take a special care of the OSH (Occupational Safety and Health). During making components of the battery, similarly like in all other steps of this procedure, or in all other research and development activities, special attention of the builder should be directed at safety, at avoiding health hazards, at preventing the research facilities from access by unauthorised people (especially children), at screening against effects of a possible explosion, at readiness in case of a fire or electrocuting, etc. After all, mercury and vapours of it are poisonous, a vacuumed tube may implode at any moment, inductors and exposed wires may electrocute, sharp edges and non-rounded tips may harm someone who falls onto them, ellipsoidal quartz crystal may focus sunrays like a lens and initiate a fire, capacitors charged with electricity may begin to spark and start a fire or electrocute someone, etc.

#7. Assembling the prototype of the telekinetic battery. The aim of this step is to obtain a prototype of the telekinetic battery that later can be subjected to functional experiments. This prototype should not differ too much from the original specification determined by principles of operation of this device (see subsections LA2.4.1 and LA2), for example in the tube (T) should be vacuum of the exactly determined value (so that the next time we repeat this procedure we can select a better value of this vacuum), design and work parameters fulfil the requirement of harmonics, etc.

After this step is completed, we have assembled the complete prototype of a telekinetic battery. But before we subject this prototype to any research, we firstly need to conduct a kind of "quality check", i.e. we need to verify if everything in it is completed and connected in the required manner. For this, for example all electrical connections of the prototype need to be compared to the diagram from Figure LA7. In turn the positions, attributes, and polarities of every component need to be compared to the descriptions from the beginning of chapter N, and also from subsection LA2.4.1. Furthermore, we need to determine (and thoroughly record it into our logbook) all technical details of our prototype, especially such as resistances, directions of winding and polarities (e.g. for inductors and for the tube), number of coils, way of connecting (e.g. which inductor and which side with what), dimensions, frequencies, etc.

#8. Research and tests completed on the prototype. The goal of this step is to verify the functioning of the prototype we just assembled, reasoning on this basis about various construction and completion errors we committed this time, and then working out the further improvements. The correct planning and skilful conducting of this research, as well as deriving from it the constructive conclusions, is the most critical step in our developmental procedure, which determines the final success in the completion of the telekinetic battery. The description of some guidelines for the completion of this step is provided in subsection N2.6.2 of this monograph. Generally speaking, this step should concentrate on determining, amongst others, the following matters:

(a) Whether the location and the piezoelectric parameters of the quartz crystal are correct (e.g. the correctness of the location of this crystal exactly in the telepathic focal point of the aluminium pyramid, can be determined through the gradual change of position of this crystal and analysing the electronic signal that it produces).

(b) Whether the polarity of inductors and the value of their telekinetic thrust are adequate (e.g. in order to verify this, the developer may experiment with different polarities of inductors, or with inductors wound from a different number of coils and on different permanent magnets).

(c) Whether the electrical connections between the battery's components are correct (e.g. for checking these one may temporary change the way wirings are connected, and then determine what influence such a change has on the impulses induced in the battery's circuitry).

(d) Whether the resonance frequency of the electronic circuitry (namely the resonator) is well tuned to the working parameters of the battery (e.g. for this, the developer may direct forced electronic impulses of several different frequencies to the both terminals of the quartz crystal, and then see what is the response of the battery's resonator).

(e) What parameters of the current induced in the battery are needed to cause the glow of the tube "T", and how to make the battery to produce a current with such parameters (e.g. the developer may change the telekinetic thrust formed by inductors, alter the resistance of shunt coils over the tube, change the resistance of the tube, etc.).

In our experiments we should give preferences to quantitative research and measurements, i.e. to those directed towards not only determining that something has happened or appeared, but also how much of it could be detected, what is its direction and characteristics, what is the source, how we can modify (e.g. intensify) it, what conditions must occur for it to appear, etc. It is also extremely vital that in our logbook we write down the description of experiments and tests that we completed, and the description of results that we received. Our research we need to direct in such a manner that they lead us to drawing useful conclusions which in turn allow us to improve gradually the construction of our battery, so that in the final effect we make this device operational.

#9. Securing the knowledge just learned from being lost. Each attempt at researching a new prototype leads to a number of findings which represent the practical knowledge gained in a given iteration of battery's completion. This knowledge should be secured from being lost. The first principle of such securing is to write it down in our logbook. The knowledge which is not written down is likely to be lost, because of our memory limitations, because we did not purified it and presented in the form of clear conclusions, and because of many other reasons. Only the knowledge which is thoroughly recorded can be reused again during the next turn of the iteration process. After the knowledge is written down, it also should be shared with others. Knowledge which is not shared is also likely to be lost. After all, if others do not know what we accomplished, then when we are gone or changed our interests, also all that we accomplished is gone. For this reason, after being written down the conclusions from a given step should be copied and posted to someone, preferably to myself. (Note that in case of the battery described here, keeping knowledge to ourselves is both: dangerous and pointless.) Such sharing the knowledge has also this additional advantage that it minimises the danger of alien assassination. After all, aliens may only decide to assassinate a developer, if this assassination gives them a good chance that the results accomplished by this developer are going to be lost after his/her death. But if the developer shares his/her knowledge with others, then such a loss of accomplishments is prevented.

#10. Extending, complementing, or refreshing our knowledge. The goal of this step is to gain additional knowledge which is necessary in order to introduce to the battery all these further improvements which result from our research on the previous prototype advanced according steps #1 to #9. To complete this step, it is recommended to refresh or increase our knowledge regarding the type of circuits or phenomena which in the course of our experiments turned out to be the most important for understanding and improving the prototype. It is especially recommended to read descriptions of such phenomena as: the technically induced telepathic waves, the Telekinetic Effect, principles involved in the operation of telekinetic batteries, principles involved in the operation of telepathysers. These, together with descriptions of the battery discussed here, are extensively presented in this monograph [1/4] and in treatise [7/2], while partially also in [1E], [8], and [6E].

#11. Repeating the development and research procedure for further, improved prototypes of the telekinetic battery. The goal of these steps is the gradual removal of errors or imperfections which were detected in previous prototypes, according to the general principle of "iteration method". To complete these steps we: (a) select from steps #1 to #8 these ones which according to the results of our research, experiments, and deductions completed on the previous prototypes require redoing, (b) complete these selected steps again, thus receiving a next set of battery's components with different design, technology, or

technical parameters, (c) we check with the descriptions from chapter N if our changes are not running against the original specification or the principles utilised for the operation of this device, (d) we complete again steps 9 to 13 of this developmental procedure.

At this point it should be emphasized that the first completion of the above procedure most probably will not result in the production of an operational prototype. However, it will furnish the builder with empirical experience which should equip him/her with a better understanding of interpretations and descriptions presented in this publication, as well as in [7], [3], [6], and [1/3]. Furthermore, it should provide a higher starting point for the subsequent repetitions of this developmental procedure. This in turn should create a pool of experience and theoretical knowledge which would allow for a substantial improvement of the prototype in each subsequent repetition. Thus, at some stage of this developmental procedure, the prototype may eventually be achieved which would be capable of operating exactly as illustrated in the original disclosure. This final working prototype would be the one which is to be later duplicated in the commercial (mass) production of the battery discussed here.

From the world fame and huge interest that were induced by the first public demonstrations of telekinetic free energy device "Thesta-Distatica", it is already known what is to happen in case when someone accomplishes a success in constructing the telekinetic battery described here. Because the religious community "Methernitha" decided to not disseminate devices that it builds and until today keeps in secrecy their most vital technical details, the eventual constructing the telekinetic battery would provide the first free energy device which can be opened for the mass production and for commercialization.

LA2.4.3. History of invention of telekinetic batteries

I invented the device named here a "telekinetic battery" in 1989 (I also call it the "telekinetic cell"). Here is the brief description of history of this invention.

Theoretically I was aware of enormous potentials that the Telekinetic Effect introduces to the production of free energy, from the very moment when I discovered this effect and realized that it represents the exact reversal of friction - i.e. since 1985. But the technical idea which explained how practically we can utilise this effect for the generation of free energy come to my mind only in 1989. In the time of conceiving this idea I was working on the scientific paper **[1LA2.4.3]** entitled "Premises for the feasibility of motors utilizing principles of telekinesis" which I was to present at the ANZAAS Congress (session on Energy and the Greenhouse Effect), University of Tasmania, Hobart, 14-16 February 1990. (Address of the organizers of that Congress: Organising Secretary, 1990 ANZAAS Congress, University of Tasmania, GPO Box 252C, Hobart, Tasmania, Australia 7001.) I already had guaranteed finances for my participation in that congress by the Otago University from Dunedin, New Zealand, in which I then worked as a senior lecturer. Also my paper was already accepted by the organisers of that congress.

My paper was attempting to explain on the basis of the Telekinetic Effect, principles of operation of three free energy devices that already existed at that time (i.e. in 1989), but the operation of which remained then unexplained. Namely it explained principles of the Johnson's "permanent magnet motor" - i.e. a motor which uses only permanent magnets, the De Palma's "N-Machine" - i.e. a generator which utilises a solid magnetic disk firstly introduced by M. Faraday, and the Methernitha's "Thesta-Distatica" - i.e. a telekinetic free energy device which utilises electrostatic force interactions. However, during writing it I realized that the Telekinetic Effect can also be released inside of a coil composed of conductive wires. In case of such a release, all free electrons that saturate this coil, would be pushed to flow in one direction, and this would produce a significant electric current. In this way the telekinetic battery was invented. (The coils in which the telekinetic generation of electricity takes place are inductors (I_1) and (I_2) shown in Figures LA7 and K1.) At the time when I invented the telekinetic battery, I was the

first scientist on Earth, who invented and who described this earlier unknown manner of generation of free electricity.

The first description of the "telekinetic battery" I already provided in the content of my Tasmania paper [1LA2.4.3]. The paper received a positive reference and was included into the congress' program. However, the Otago University in Dunedin, New Zealand, in which I was employed at that time, in the last moment refused the financial support for attending this congress, in spite that this support was promised to me from the first moment I proposed my paper. This is because the timing of the Tasmania congress was coinciding with the culmination point of the hysteric outcry that my scientific colleagues at the Otago University were carrying out in the response to my discovery of the UFO explosion site near Tapanui - as described in subsection W4. As my scholarly superiors and colleagues were telling it to me verbally at that time, they were refusing to finance my participation in that congress because my paper, similarly to monograph [5_E] describing the Tapanui explosion, "are contradictive to the existing knowledge", and the presentation of this paper at the congress would introduce a threat for the authority of the Otago University. (Interesting that the referees working on behalf of the organisers of that congress did not share this opinion, and accepted my paper on its own merit, to be presented at the congress.)

After I realised that I am not able to participate in that congress, I turned to the only person from New Zealand who was also attending it. (This person was then a director for research and development in "Electricorp" corporation of New Zealand - i.e. an institution that should be specially interested to learn and promote the idea of telekinetic generation of electricity.) I asked him to present my paper on my behalf, providing him with all slides, copies of the paper, and other materials plus explanations necessary for this purpose. But instead of presenting my paper, he - without any prior consultations with me, withdrawn the paper from the congress' program. In this way the person who actually was drawing his salary for promoting the progress in the area of electricity generation, judged my newly born "telekinetic batteries", and convicted them to be burned on stake.

Shortly after these incidents with my breakthrough paper, I was also fired from my lecturing job at the Otago University in Dunedin. This firing had a suppressing effect on the completion of telekinetic batteries and other free energy devices described in this chapter. The reason was, that if I continued to work at the Otago University, most probably I would complete a prototype of one of these devices. Just before being fired from the job I already purchased all components needed for the construction of these devices, and I prepared myself for initiating their physical completion. Unfortunately, after being fired from the job, I was unemployed for next two years, so the first priority for me became then to survive and to find another job, not to build telekinetic batteries.

The total failure of this my first attempt at presenting the "telekinetic batteries" to scientific fraternity, inspired my searches for the explanation why my breakthrough discoveries and inventions got this oppressive treatment from the Otago University, which they got. In the result of these searches, I gradually started to discover the fact that our planet is occupied by the parasitic UFO-nauts - as this is described in subsection W4. This discovery was rather a lengthy process. Because it was so revolutionary and so shocking, even with my open-minded philosophy it still required a lot of time to get through, as it firstly needed to shatter totally my entire old believe system. With the elapse of time I also gradually discovered that these our cosmic parasites are intensively blocking our knowledge in every area that could significantly advance our civilisation. So I come to the conclusion that there is no way I could present such a revolutionary idea at any official scientific forum, and I decided to present my battery through other channel, namely via my "resistance literature" - i.e. treatises and monographs that I publish privately outside of the scientific mainstream and disseminate through the Internet. Thus, since I invented the "telekinetic battery", I am describing this invention in almost all my treatises and monographs that are published after 1990 - see monographs [6] and [6_E], monographs [2_E], [3], [3/2], [1/2], [1/3], and the present [1/4] one. The most comprehensive and the most up-to-date description of the telekinetic battery is provided in this chapter.

The principles of the telekinetic battery are employing the phenomenon which takes place only in the counter-world, namely the reversal of friction named the "Telekinetic Effect" and described in subsection H6.1. The discovery of this Telekinetic Effect introduced significant implications to all heat and motion related sciences. This is because mastery of the reversal of friction could be compared to a capability of eliminating friction itself. For example, this new phenomenon allows to abandon the to-date principles of conventional heat machines which must build-up a significant gradient of temperature in order to convert a flow of thermal energy into motion. Machines utilizing the Telekinetic Effect, including the **telekinetic batteries** described here, do not require any temperature gradient, and still are able to extract thermal energy from the environment and convert this energy directly into motion. (Means such machines work exactly like this hypothetical "Maxwell Demon" described in literature of classical physics.) The operation of these new machines involves: (1) the technical release of the Telekinetic Effect, (2) the absorption of thermal energy contained in the environment and its transformation into a useful form of motion, (3) the channelling of the produced motion so that it moves a stream of electrons inside of coils made of a conductive wire. In turn this stream of electrons, in our world constitutes a technically useful flow of electric current. The application of this current allows to obtain a free source of unlimited electrical energy (hence the expression that the telekinetic batteries are "free energy generators").

LA3. Telekinetic devices for the conversion of biological, chemical and thermal energy

Independently from all applications listed before, the Telekinetic Effect allows also to induce telekinetic phenomena that run along the "line of the highest resistance" (as this is described in subsection LB3). From the energy point of view, the most interesting amongst these phenomena are: the regeneration of living organisms, changes of phase in substances from states of lower energy into states of higher energy (e.g. the dissociation of water into hydrogen and oxygen), and causing heat to flow from an area of lower temperature to an area of higher temperature. Examples of these types of phenomena that appear in nature, can be the action of healers, or the so-called Spontaneous Human Combustion – described in many books. Technical versions of these phenomena already found applications in operation of newly-developed devices for the telekinetic production of medicines, for the telekinetic dissociation of water, and for telekinetic heating. Such devices were constructed already, and they proved themselves highly effective in action. This subsection is going to review briefly the most interesting amongst them.

LA3.1. Telekinetic healing and production of medicines

As this is explained in subsections H1.2 and LB3, healers utilise the natural form of the Telekinetic Effect, to regenerate living cells. Their healing actions usually limit themselves to directing the telekinetic field generated biologically by the healer at ill organs or cells. In turn the field returns ill organs or cells to the state of health and proper functioning. The Swiss researcher, the late Werner KROPP from the Wekroma Laboratory (address in 1990: Via Storta 78, CH-6645 Brione s/M, Switzerland) conceived an idea to construct special devices, which utilize a technical version of the Telekinetic Effect for healing purposes. The first of his devices took a form of a large loop, or frame, that contained a long coil inside. Into this frame or loop a sick person, or a bed with such a person, is placed. Then the coil is supplied into pulsating current of appropriately selected parameters. Pulsations of the magnetic field that propagated from this coil onto the sick person caused a gradual regeneration of ill cells and organs. In this manner the first telekinetic healing machines were constructed and utilized in practice by the Wekroma Laboratory.

Even more vital discovery of Werner Kropp was the finding, that sterilized water with addition of 0.7% solution of kitchen salt (i.e. the water which constitutes the base for human blood), displays the extraordinary capability of accumulating the Telekinetic Effect and later releasing this effect in the person which drinks such telekinetised water. This extremely vital discovery provided Werner Kropp with a principle for developing the production of telekinetic medicines. This production depended on constructing a special device, in which the appropriate configuration of magnetic fields caused the accumulation of the Telekinetic Effect in the ampoules of water that are transported through this device. Telekinetic medicines obtained in this manner contained only such telekinetised water. After the telekinetisation, these ampoules of water were supplied to sick people. Due to drinking such telekinetised water, sick people recover their health. Telekinetic medicines produced by the Wekroma Laboratory turned out to be a real bestseller in Switzerland. Their consumption was growing very fast during the lifetime of the late Werner Kropp. The most vital advantage of such telekinetised water was, that while being extremely effective, it simultaneously did not induce any undesirable side effects. For example it allowed drug addicts to get rid of their addictions without the undesirable "cold turkey" syndromes.

Principles of both above devices Werner Kropp combined later together into the form of an extension to the kitchen tap for household use. This extension saturates water which flow through it, with the Telekinetic Effect. Consumers of water telekinetised that way claim, that the process not only clearly improves the taste of water, but it also decisively uplifts their own health and well-being.

Unfortunately, this evil force that constantly operates on Earth, is doing everything in its powers to prevent our civilization from mastering technical telekinesis. This dark force, amongst others, caused also an unexpected and premature death of Werner Kropp in the middle of his creative years - as this is described in subsection N1. So the promising inventions of this dynamic entrepreneur were brought to a sudden stop.

LA3.2. Telekinetic dissociation of water

The reversal of friction behaviour of the Telekinetic Effect, can also be utilised for the reversing of chemical reactions that produce thermal energy. A technical application of this process, is the telekinetic dissociation of water into the so-called "Brown's gas" $H_2 + O$ (i.e. hydrogen plus oxygen). In turn, such a gas is suitable for the pollution-free burning in almost every device build so-far. (Instead of combustion gases, the burning of the Brown's gas produces only water steam.) Apart from many obvious applications of this gas, such as heating of homes, cooking, welding, iron casting, etc., the most promising seems to be the utilisation of it for fuel in cars of the future. (For example, the German company BMW, has a working prototype of a car since 1990, which is propelled by burning a mixture of hydrogen with the air.) For the purpose of such utilisations, it is predicted a special telekinetic "cell" to be build into a given car. The purpose of this cell is to dissociate water into hydrogen and oxygen. Hydrogen would then be supplied to the engine, where it would be subjected to burning. The interesting here is the fact, that experimental cars of this type already managed to gain a noticeable fame as the so-called "cars run on water".

According to the present understanding of the work of telekinesis, an effective dissociation of water via the use of the Telekinetic Effect, will be very similar to such a dissociation that utilises electric current. However, in the telekinetic device, instead of work of electricity, the work completed by accelerated magnetic field is needed. For this reason, we can deduce, that the future device that will effectively carry out the telekinetic dissociation of water must contain three basic components, namely: (1) (telekinetic) deforming resonator, (2) magneto-lyser, and (3) (electrostatic) ions neutraliser. The most difficult and the most vital of these components is the telekinetic deforming resonator. In the process of telekinetic dissociation of water, this resonator is a functional equivalent of inductors (I_1) and (I_2) from

telekinetic batteries. The function of this deforming resonator (1) depends on supplying particles of water with special type of acoustic vibrations. These vibrations must on one hand be appropriately deformed. On the other hand their frequency must be synchronised with the vibratory frequency of the particles of water. The deformation of curves of these vibrations must allow for the formation of imbalanced vector of acceleration. Such a vector must be able to produce the Telekinetic Effect when it acts upon a magnetic field. On the basis of my to-date knowledge of telekinetic devices, I imagine such a resonator as a system of two parallel electrodes (e.g. a hemisphere or a bell inside another hemisphere or a bell), which are appropriately harmonised for mutual resonance and for mutual distance, and which are placed within the range of a powerful magnetic field. The shape of these electrodes is going to be vital, because from this shape depends the formation of imbalanced vector of accelerations (i.e. the vector that is capable of forming the Telekinetic Effect). Both electrodes are supplied with the alternating current of predefined frequency (which harmonises with the resonance frequency of particles of water, and also with own acoustic resonance frequency of electrodes). In this way electrodes are to generate a standing acoustic wave (resonate), which is to bounce forth and back between them. This acoustic wave is to accelerate particles of water within the range of a powerful magnetic field that saturates this water, thus inducing the Telekinetic Effect. Appropriately configured magnetic field that is required to form the Telekinetic Effect, is to be supplied by the magneto-lyser (2). Vibrations of water saturated by this magnetic field and accelerated by the deformed acoustic wave are to release the Telekinetic Effect. In turn this effect is to dissociate telekinetically the particles of water. The energy needed for this dissociation is going to be supplied by the Telekinetic Effect, not by a given dissociating device. Atoms of hydrogen and oxygen released in this way from their mutual binding, still require shifting into opposite directions by constant electrostatic field, and catching as separate gases. This shifting and catching is to be done by the ions neutraliser (3). It is to take the shape of another two electrodes charged electro-statically and placed on opposite ends of the device. By these electrodes both gases will bubble to the surface, where they are to be gathered and supplied to the gas burners. It is worth to notice, that due to employment of the Telekinetic Effect for completing the most difficult work of splitting particles of water, such telekinetic dissociation devices consume only a small fraction of energy that is consumed by present conventional devices for dissociation of water. So the efficiency of the telekinetic dissociation surely exceeds this "magical" for orthodox scientists barrier of 100%.

In 1990 I learned about two inventors that were working on the development of devices of the above type. The first of these was Stanley A. MEYER (address in 1990: 3792 Broadway, Grove City, Ohio 43123, USA). He claimed, that the energy efficiency of his dissociation devices already then exceeded 100%. He was an owner of several patents in the USA and Canada, which describe his "Water Fuel Cell". These patents indicate that the operation and general design of his cell quite well corresponds to the above description of the device for telekinetic dissociation of water. Another inventor was Stephen HORWATH (address in 1990: P.O. Box 3880, Sydney, NSW 2001, Australia). He patented the "Hydrogen Cell" with his USA Patent No 4,107,008. The general design and operation of this Horwath's cell also coincides with the telekinetic device described here. Only that in the Horwath's device the function of an acoustic resonator is replaced with the beam of electromagnetic rays. Therefore the magneto-lyser in his device could be replaced by the conventional electro-lyser. For these reasons, in 1990 when I was carrying out research on telekinetic processes, the energy efficiency of Horwath's process was at the level of 80% (it was still much above other conventional devices for dissociation of water, produced at that time).

LA3.3. Telekinetic heating and evaporation of liquids

The inventor of a revolutionary free energy device for telekinetic heating and evaporation of water or other liquids, is Mr Peter Daysh DAVEY. (In 1990 he lived under the

address: 257 Locksley Avenue, Christchurch, New Zealand, home tel.: +64 (3) 855836.) Starting from 1944 Mr Davey obtained in New Zealand a whole series of patents on a heating element that is supplied into energy from a single phase home electricity mains of 220 Volts and 50 Hertz frequency. (Means that his heater was supplied with a normal current from mains used in our present households of Europe and New Zealand.) Details of his first patent for this heater were as follows: New Zealand Patent Nr 92.428, dated 12 December 1944, for an "Immersion Heater". His free energy device was designed to be used as a heating component build in electric jugs, and also for home electrical heaters, as well as a small electric heating implement inserted if necessary into glasses and ceramic mugs. Because the Davey's invention discloses a general principle on which the phenomenon of technical telekinesis can be utilized for the generation of huge quantities of "free heat", I decided to present it here in more details.

The design of the Davey's heater is extremely simple. It actually is composed of two major parts only – see **Figure LA8**. The most important out of these two parts is a resonating hemispherical bowl (1) made of a sound inducing metal plate. The second part is a buffering hemispherical bowl (2) almost identical in shape to the bowl (1). It has the radius around 4 mm larger than the resonating hemispherical bowl (1). Both bowls are assembled symmetrically one around the other, means the hemispherical bowl (1) is placed inside of the hemispherical bowl (2).

During an experimental production of this heater, the resonating hemispherical bowl (1) usually is made from an old cover for a bicycle bell. The dimensions of this hemispherical bowl are not important. It is only vital that it falls into a sonic resonance at the frequency of 50 Hertz, and that it has the outer surface which is approximately parallel and equidistant from the external buffering hemispherical bowl (2). The entire heater, including both bowls, is assembled onto a kind of elongated handle (8). This handle is actually a pipe with a constant diameter, through the interior of which run two isolated cables (6) and (7). The pipe (8) is made of some resistant to temperature, elastic, and not conductive to electricity material (e.g. nylon, teflon, etc). Along this end of the pipe (8), which holds both bowls, the external thread is cut in. The outer buffering hemispherical bowl (2) is assembled first onto this elastic pipe (8) and kept in a permanent position with the aid of a nut (5) placed over there before it. In turn the inner resonating hemispherical bowl (1) is assembled later at the end of an elastic pipe (8) and kept over there in position from one side by a separatory washer (4), while from other side with the aid of a nut (3). Due to such assembling of the heater, the buffering bowl (2) has the inner surface parallel to the hemispherical bowl (1) and distant from this bowl by the experimentally selected constant distance "L" (this distance usually amounts to around 4 mm). In order to control precisely this distance "L", between both bowls a separatory non-conductive washer (4) is assembled, the thickness of which is experimentally adjusted through grinding it during the "tuning" stage of this heater. The buffering bowl (2) is kept in the position by being pressed with the nut (5). Two elastic insulated wires (6) and (7) running through the interior of the pipe (8) supply electric current to both hemispherical bowls of the heater. The wire (7) is emerging from this pipe (8) through a hole that is drilled especially for it. In turn the wire (7) emerges through the end of pipe (8). Each wire is pressed against, and electrically contacted with its bowl, with the aid of a nut (5) or (3). In the supply of electricity to bowls it is vital that the resonating bowl (1) is connected to an active phase of the electricity supply (i.e. to this wire (6) which conducts the current). In turn the buffering bowl (2) should be connected to the earthed wire (i.e. to this wire (7) of the power supply that represents Earth in our household electrical wiring).

After being constructed, the Davey's heater must be "tuned" in two different manners. The **first tuning** depends on providing the hemispherical bowl (1) with such frequency of the own oscillations, that makes this bowl to resonate acoustically when a sound of the frequency 50 Hertz is emitted nearby. Practically this tuning depends on grabbing with "feeling" the elastic rod (8) on which the resonating hemispherical bowl (1) is assembled, and then placing this bowl close to any source of the sound with frequency of exactly 50 Hertz, so that we can

sense whether it vibrates in tact of this sound. (E.g. placing this bowl near to a buzzing electrical transformer, a tuning fork (i.e. kamerton) - 50 Hz, piano - low D, saxophone - low B, etc.) If the vibrations are not sensed, then on a grinding machine we should take a thin layer of the material from the face (T) of this bowl (1). Then we again place the bowl near a source of 50 Hertz sound and again try to sense the vibrations. This process we repeat so many times, until the hemispherical bowl (1) starts to response with the resonance to every appearance of such 50 Hertz sound.

The **second tuning** of the heater depends on appropriate selecting the distance "L" between both bowls (1) and (2). On this distance depends the formation of the standing wave between both bowls. Thus it decides about the energy efficiency of the entire heater. In general, this second tuning depends on the measurement: of the amount of electricity consumed by the heater and the time needed for this heater to boil a given volume of water, as a function of distance between both bowls. Through measurement of these two parameters the optimal value of mutual distance between both bowls is experimentally determined. For this optimal distance a given volume of water is brought to boiling in the shortest possible time, while simultaneously the heater is consuming the minimal amount of electrical energy. For this optimal distance, the Telekinetic Effect formed by the standing electromagnetic wave is the most powerful.

It is interesting that in his patent indicated above Mr Davey did not describe the details of the "tuning" of his heater. In turn, without this tuning the accomplishing the efficiency of this heater in excess of 100% is impossible.

The operation of the Davey's heater boils down to the appropriate directing the Telekinetic Effect that it generates. The electrical field formed between both bowls by the alternating electric current, polarizes magnetic dipoles of individual particles of water. Simultaneously the changes of this current cause acoustic vibrations of the resonating bowl. These vibrations are passed onto particles of water, thus causing the acceleration and deceleration of magnetic dipoles from water particles. The optimal selection of the mutual distance between both bowls forms the appropriate configuration of the acoustic waves, thus directing the action of these temporary accelerations and decelerations. In the result the powerful Telekinetic Effect is released. This effect causes the influx of external thermal energy into the water and the gradual heating of this water. It is worth to notice, that the thermal efficiency of this device depends only on the characteristics of the heater itself, not on parameters of the liquid. Thus the heater may be utilized for heating, boiling, and evaporating any possible liquid, not just water.

The unusual attribute of the Davey's heater is that it was experimentally proved to telekinetically shift to the heated water many times more of thermal energy, than the amount of electrical energy it consumes. I myself did not research the energy efficiency of this heater. However, from the information that the inventor repeated to me, I gather that the measurements carried out by New Zealand scientists suggested, that this heater may consume even less than the equivalent for around 5% of the energy that it generates in form of heat. This would indicate, that the electrical efficiency of this heater is around 2000%. (Means, that the heater produces over 20 times more energy in form of the heat, than it consumes in form of electrical energy.) Such a high efficiency allows this heater to be utilized as a basis for the so-called "perpetual motion" device – also called "perpetuum mobile". **(Because present orthodox science claims that the construction of "perpetuum mobile" is impossible, the heater discussed here carries the potential to visually prove that present science is based on wrong foundations.** In this way the mass production of this heater has the ability to revolutionize our understanding of reality.) This is because the heater is enough efficient to overcome the low efficiency of present steam engines. So it practically allows to be used for steam generation, while the steam it would produce could be supplied to a steam engine, while the operation of this steam engine could propel an electricity generator, which in turn would again supply the heater with the required electrical energy thus allowing the generation of steam, etc., etc. Several orthodox scientific institutions in New Zealand had a

very hard time to explain on the basis of today physics what is the reason for this extraordinary, over 100%, efficiency of this device. After all, it contradicts all known laws of thermodynamics. Finally one of these institutions (i.e. the New Zealand DSIR) got an idea, or rather an accusation, that this heater instead of the electric current may consume the so-called "cosine fi" - i.e. the abstract quantity that represents a phase shift between the pulsations of the voltage and pulsations of the amperage in the alternating current. This particular parameter is immeasurable with the standard electrical instruments. But even the specialized measurements and research carried out by these scientists have not confirmed this claim/accusation. Still, in spite that it was never confirmed experimentally that this heater really consumes the "cosine fi", due to insisting on this deceitful explanation the authority of the orthodox science was saved.

The highly meaningful is also the analysis of the further fate of the Davey's heater and fate of the inventor himself. Having the device, which repetitively proved to everyone who measured it, that it has the efficiency decisively exceeding 100%, the inventor believed that the world is going to pounce on the opportunity of production and use of this technical miracle. After all, people are full of declarations about apparent saving on energy, resources, about protection of our natural environment, etc. However, the reality turned out to be completely opposite. Immediately after it was experimentally confirmed that the device has unexplainably high efficiency, the heater and the inventor fell into disfavor of various institutions that are interested in selling electricity and protecting the monopoly on electrical power. In the result, this extraordinary invention received an extraordinary treatment. Namely, until today it is impossible to undertake the production and sale of it in New Zealand. One of the legal tricks that were used against this heater, was that it was officially declared to be "unsafe to health and life of users". (Please notice, that practically every electrical device which operates on 220 Volts can be declared unsafe, if someone in the position of authority wishes to put it down.) In turn in New Zealand it is impossible to undertake the production and sale of anything, that is not officially approved by the government. In the result, the production of the heater presented here could not be undertaken at all. But it is interesting, that in Australia in mass production was an electric jug with a heating element of the design very similar to the Davey's heater (this jug most probably is produced in there still even today). This Australian jug is working on the principle of electrical resistance of water. Water that it heats is a resistor, in which heat is generated because the electric current flows through this water. This Australian jug is exactly the same "dangerous to the health and lives", like the telekinetic heater of Mr Davey. Only that it did not encountered in Australia similar bureaucratic resistance because the energy efficiency of it is "normal".

In present days the Davey's heater is completely forgotten in New Zealand. It was no any help to it, that the energy efficiency of this heater was proven at the miraculous level of much above 100%. In turn the inventor of it – after many years of fruitless battles and Sisyphus efforts towards undertaking the mass production of it, finally gave up not only in the matter of this heater. When I talked to him for the last time shortly before I needed to leave New Zealand in 1992 to seek my bread overseas, he was completely broken, deprived the will to live, and on the edge of a nervous breakdown. He could not understand why offering to the world a breakthrough free energy device of the experimentally proven efficiency that well exceeds 100%, he receives back only scoffing, persecution, and bureaucratic plus legal obstacles that make impossible the production of this miraculous device. When in 1998 I returned from overseas and tried to contact Mr Davey again, in the place where his home stood previously I found only a large pile of broken wooden planks mixed with broken bricks. It looked as if several heavy tanks rolled through his home. In turn no even a trace of him. I also was unable to locate anyone, who would know what actually happened to him. In turn after 1999, as I explained this in subsection W4, it has not been in my fate to let me go to Christchurch again.

At the end of this description I would like to encourage all people who have the required conditions and skills, to undertake the construction of the telekinetic heater described here. In

this way the creative invention, as well as years of suffering of Mr Davey from hands of bureaucrats who persecuted him, will not be wasted. In turn after the heater is constructed, it should be quickly put into a mass production. On the occasion of this encouragement I would also like to remind the condition specified in subsection AB2. It states that in case of a financial success with any device described in this monograph, the accomplishers have the obligation to designate 10% of the pure profit they accomplish towards the fund which is to support avant-garde research of the type described in this monograph.

LA4. Reaction of orthodox scientists - means difficulties of crushing a wall with our own head

For a long time after 1990 I did not repeat my efforts to present the telekinetic free energy devices to scientific fraternity. I knew that our cosmic parasites would again find a way to make such a presentation impossible. Thus all my perseverance in this direction would prove to be just a waste of time and energy. I experienced jolly well how hopeless such efforts could be, because continually since 1980 I was trying to publish a scientific (refereed) article or paper about my Magnocraft, and all these years of my perseverance proved themselves totally unsuccessful. But in 1997 I decided to have another go with the telekinetic battery. This was mainly because at that time I was researching these undetectable methods which UFO-nauts use to put us down, and I was curious to find out what method this time UFO-nauts will use to make impossible the presentation of my telekinetic battery. So in 1997 I proposed a scientific paper entitled "The Telekinetic Effect - a phenomenon which converts thermal energy directly into motion" to be presented at the 11th International Heat Transfer Conference in Kyongju, Korea, which was to take place on 23 to 28 August 1998. (The address of organisers of that conference was: Prof. J.S. Lee, Department of Mechanical Engineering, Seoul National University, Seoul 151-742, Korea, E-mail: jsleeng.snu.ac.kr; while the address of the representative for the South Pacific (Australia, Asia, Malaysia, etc.) through whom I forwarded my paper was: Professor Graham de Vahl Davis, Australasian Fluid and Thermal Engineering Society, School of Mechanical and Manufacturing Engineering, University of New South Wales, Sydney, NSW 2052, Australia, E-mail: g.devahldavis@unswayed). At that time I was a professor at university in Borneo, the finances for my participation in that particular conference were promised to me in writing, and also being taught by my previous experiences I wrote my paper very, very carefully. But still on 24 November 1997, I received a letter from the representative of that conference. The letter was dated on 11 November 1997 and was telling, quote: "I have now received the reviewer's report on your paper "The Telekinetic Effect - a phenomenon which converts thermal energy directly into motion" and enclose a copy. Under the circumstances, I regret that I have no option but to reject your paper. Thank you for your interest in the 11th International Heat Transfer Conference. Yours sincerely, ...". There was a small piece of paper enclosed with this letter, which held no signature nor any details of the writer, and which supposed to represent this negative "reviewer's report". This piece contained several very badly formulated sentences, which I am repeating here in their exact wording (including the machine and stylistic mistakes which they contained), quote: "This paper is a list of claims that a wide range of phenomena in thermodynamics and biology can be explained by the existence of a parallel universe with inverse properties to the normal universe. The paper is a series of undocumented claims an out the power of the telekinetic effect e.g. --- "telekinetic motion is like forcing an object to move by shifting its reflection in a mirror so that this re-located reflection causes the object to move also" --- . --- "women subjected to telekinetic effect action, or to the action of telekinetized substances are improving their fertility", and many similar claims. The testing of the telekinetic effect is not documented. The one claim to the existence of a machine that demonstrated the effect is an interpretation by Mr Pajak of the machine's operation that is not supported by the designer of the machine. I would suggest that the author concentrate on

actually demonstrating one of the myriad of benefits that he claims can be derived from this new phenomena before publishing such earth shattering papers as this." The mind boggling aspects of this "reviewer's report" include, amongst others, strange emotions which are permeating through these few sentences, the fact that the "referee" calls me "Mr Pajak" in spite that the paper was providing my full scientific credentials - including the information that at that time I was an university professor, and in spite of fact that in correspondence between scientists it is customary and courteous to provide at least one, i.e. the highest, title.

It is interesting that if a given negative phenomenon becomes so dominating that the society starts to clearly notice it, firstly films are made about it, then books are written, next popular jokes are told, and finally movements and rebellions began which try to curb it. About the close-mindedness and impracticality of today orthodox scientists already films were made and books were written. Recently popular jokes also started to appear. Here is one of them. In a TV competition which depended on inventing and telling an event which would be the most improbable to happen in reality, took part: an economist, a politician, and a scientist. The economist said "after suggestions postulated by a famous economist were implemented, the situation of the country in fact did improve". Jury was convinced - yes, economists of that calibre do not exist any more. Then the politician had his go. "Our leading politician in fact did fulfilled all the election promises after he become a leader". Jury was impressed - yes, politicians of that calibre are already extinct species. Finally the scientist had his turn. "Once upon a time there was an open-minded scientists ..." he started. Jury stood up from their sits in the expression of appreciation - without letting him finish. Yes, this event wins the competition, as everyone knows that the finding of an open-minded scientist is impossible and thus never could happen...

The to-date history of the "telekinetic battery" and other telekinetic free energy devices, reveals that our cosmic parasites are equally determined to block the development of these devices, as they are determined to block the development of the "telepathic pyramid" described in chapter N of this monograph. It is obvious that these parasites will resort to anything what turns necessary to stop human developments in that direction. This is no any surprise for me. After all, if the telekinetic battery is ever completed, our civilisation would be lifted to such a level of awareness, that the further invisible occupation of Earth by this evil parasites would become impossible.

LA5. Summary of utilisation of the Telekinetic Effect for energy production

At the present level of development, each one of the telekinetic free energy devices described in this monograph met with some form of a hidden persecution, which makes totally impossible, or delays, the practical implementation of this device on Earth. For example, the inventor and builder of a given device rapidly dies in quite mysterious circumstances, while after his death there is no-one who would be interested in implementing this device into mass production. Or a given device is locked and separated from the world by some hermetic cult, which intends to release it only after the end of the world. Or rapidly from underground scores of enthusiastic bureaucrats emerge, who keep inventing various excuses to make the production of a given device impossible. According to what I wrote in chapter VB of this monograph, these types of mysterious obstacles continually cropping up on paths of specific inventions, carry all the attributes of being purposely induced by evil UFO-nauts that occupy our planet in a hidden manner. Therefore, my personal explanation for this extraordinary string of "coincidences" which persecutes the mastery of free energy by our civilisation, is that this persecution is carried out by evil UFO-nauts who occupy our planet. But even if the reader does not share my views, still by the sheer number of such strange "coincidences", he or she must admit, that something really weird happens with the inventions of free energy devices.

This hidden persecution causes, that free energy devices did not get the chance to be perfected technically. Therefore, independently from the hidden persecution, these devices have also various technical imperfections that may hold back their commercial mass production. As we learn from the history of technology, the process of gradual elimination of such imperfections takes many years – this process is illustrated in **Figure LA9**. For example, from the time of the first experiments with electricity by Benjamin Franklin in 1745, until the completion of the first effective generator by Michael Faraday in 1831, almost 90 years elapsed. But the technical imperfection and hidden persecution of telekinetic devices that effectively extract thermal energy from the environment, does not mean that the building of these devices is unfeasible. The telekinetic free energy devices already built have proven that the idea of these devices is feasible, and that their successful utilization in everyday life is only a matter of time.

The Telekinetic Effect employed in these devices has not yet been recognized or investigated by orthodox scientists. (Actually, as so-far, institutional orthodox science stubbornly refuses to show any interest in this phenomenon, and in everything that is connected with it – for details see subsections LA2.4.3 and LA4.) Thus all the developments to date involving telekinetic devices for generation of free energy are based on empirical findings and the intuition of individual inventors, or on “gifts” that various people received from a totalistic civilisation which tries to help humanity (see [7/2]), rather than on solid research of orthodox scientists and in-depth knowledge of the principles. For this reason, many free energy devices which are already built are still of low efficiency, and their output just suffices to cover the friction of their relatively moving parts. However, the history of technology teaches us, that if something can be constructed at all, it can also be improved to the practically useable level – see Figure LA9. To improve the efficiency of telekinetic free energy devices, it is necessary to design and complete a programme of extensive laboratory research on the Telekinetic Effect. Such a programme should precede the technological implementation of this effect. I am more than happy to provide initial guidance to all those constructive investigators who wish to contribute to this research.

While encouraging extensive laboratory research on the Telekinetic Effect, it is also worth to summarize benefits for the future that the technological mastery of the telekinetic free energy devices is going to give us. After all, the **telekinetic free energy devices carry potentials for causing a complete revolution in human views**. For example, these devices allow the construction of “perpetuum mobile” – means they are able to prove that theoretical foundations of present orthodox science are completely wrong. They prove empirically the existence of the counter-world in which God and our souls reside – thus they reveal that atheism is a biggest mistake of humanity. They disclose mechanisms behind such phenomena as telekinesis, telepathy, healing, ESP, etc. – thus they prove empirically that the so-called “unexplained phenomena” ignored so-far by orthodox science actually have physical justification for their existence. They open the way for constructing telekinetic propulsion systems of the type used in the interstellar Magnocraft - thus they open the door for humanity to reach to stars. They also allow for the construction of devices that reveal the invisible presence of evil UFO-nauts around us and they explain the state of “telekinetic flickering” that is used by these UFO-nauts for hiding from human eyes – in this way they prove illustratively that humanity is currently occupied by evil UFO-nauts.

In day-to-day living, the mastery of telekinetic free energy devices will also lead to individual (i.e. as opposed to centralized - which is used at present) electricity production, separate for each household. For example, telekinetic free energy devices of the size of freezers will not only maintain the required low temperature in a set room of each house (i.e. cool this room), but will also produce sufficient electric power to fully satisfy the energy needs of the household. And all this almost without any cost. Moreover, such individual free energy devices will eliminate the present need for the building and maintenance of centralized power houses, dams, power-lines, and other costly devices that have accompanying dangers, consume resources and materials, and pollute the natural environment.

Telekinetic free energy devices can also be utilized in energy supply for propelling and production devices. Telekinetic motors built into future transportation devices will eliminate the present burning of fuel, whereas production machinery supplied with individual generators of electricity will give their users independence from the central energy supply.

The utilization of the Telekinetic Effect will not be limited to the building of telekinetic free energy devices and the production of energy. Enormous prospects are also opened up by the utilization of this effect for the transportation purposes. Two different means of transportation will be built which operation will utilize this effect. These are: (1) the transporting beam, and (2) the Magnocraft of the second (and third) generation. These two inventions will completely revolutionise our means of transportation.

Progress in the technological utilization of the Telekinetic Effect will also have non-technological advantages. The most vital of these is paving the way for the recognition and learning of the biological Telekinetic Effect (i.e. psychokinesis). From the history of medicine it is known that the complete knowledge about a function of any part of the human body is possible only after a technological device that duplicates this function is constructed. A classical example is the functioning of the heart as a pump in the blood circulatory system. It is known that as late as 1628 William Harvey discovered that the heart functions as a pump. His discovery was only possible because of the earlier construction of efficient piston pumps caused by the development of medieval mining. In turn, his discovery started the development of present cardiology. From the level of present knowledge about telekinesis, it can be realized that our learning about this function of the human brain will take a similar course. Present work on telekinetic devices is paving the way for future knowledge about human telekinesis (called psychokinesis). This in turn brings us closer to the time when the unlimited power of telekinesis is adopted for medical use.

Throughout the last few decades the hopes of humanity for the resolving of its energy problems have relied on the spectacular idol of destruction called nuclear energy. To earn the benignity of this idol, for decades it was fed with human sacrifices. But while its appetite for sacrifices has grown, its promises remain unfulfilled. Only recently our attention has returned to the magnetic field. The quiet labour of this dedicated ally has helped humanity for thousands of years. But its simplicity has detracted our attention. Therefore now, when unlimited capabilities of the magnetic field slowly become realized, we should all give our support towards its investigation and peaceful utilization.

| Direction of the development of working mediums (perfecting of devices through time elapse) | | | | | | | | | | |
|--|--|----|-------------------------------|---|----------------------------|----------------------------|-----------------------------|-------------------------------|------------------------------|--------------|
| | Propulsion systems with | 3. | 1.Dislo,2.Acc. 3.Deformation | | | | | | | Future times |
| | 3.circulation of magnetic fields | 2. | 1.Dislocation 2.Acceleration | Telekinetic motor (2030) | Free energy devices | | | | | |
| | | 1. | 1.Dislocation of mag.field | Electric motor (1836) | Electricity generator:1831 | | | | | V |
| | | | | | | | | | | |
| | Propulsion systems with | 3. | 1.Uni.flow 2.Accel,3.Heat | Inter. combus. engine (1867) | | MHD generator (1946) | | Thermo-electric cell (1922) | | ^ |
| | 2.circulation of mass: energy comes from mass motion | 2. | 1.Unif. flow 2.Acceleration | Pneumatic motor (1860) | | | | | | Present time |
| | | 1. | 1.Uniform flow of work.med. | Windmill (1191) | | | | | | |
| | Propulsion systems with | 3. | 1.Mot. 2.Accel 3.Deformation | Spring (ar. 1500) | | | | Transducer:1919 piezo-elektr. | | V |
| | 1.circulation of mechanical force | 2. | 1.Uniform mot. 2.Acceleration | Flywheel | | | Machine by Wimshurst :1878 | | | |
| | | 1. | 1.Uniform motion | Drum treadmill | | | Van de Graff Machine (1935) | Electrophorus Volta (1775) | | |
| E | Type of working medium | Ge | Energy carrier | Device (kind) | Motors (relative motion) | Generators (motion of el.) | Aggregate generators | Electrostatic machines | Cells,batteries accumulators | Prog-res |
| | | ti | Technical solution | Expresses combination of energy carrier on inlet and energy carrier on outlet | | | | | | |

Table LA1. Periodic Table showing power producing devices whose operation utilizes various forms of motion. Such Tables are very similar to "Mendelée'v's Periodic Table of the Elements", but instead of chemical elements they list technological devices. Rows distinguished along the vertical axis of this Table define the subsequent attributes of the motion utilized in the operation of each successive generation of the power producing devices. This vertical axis also represents the elapse of time. Columns placed along the horizontal axis reveal the types of devices whose operation utilize each subsequent set of these attributes. Empty boxes in the Table indicate the devices still waiting to be invented. By analysis of the location of these boxes/spaces (i.e. their row and column) it is possible to determine the future operation and characteristics of power producing devices yet undiscovered.

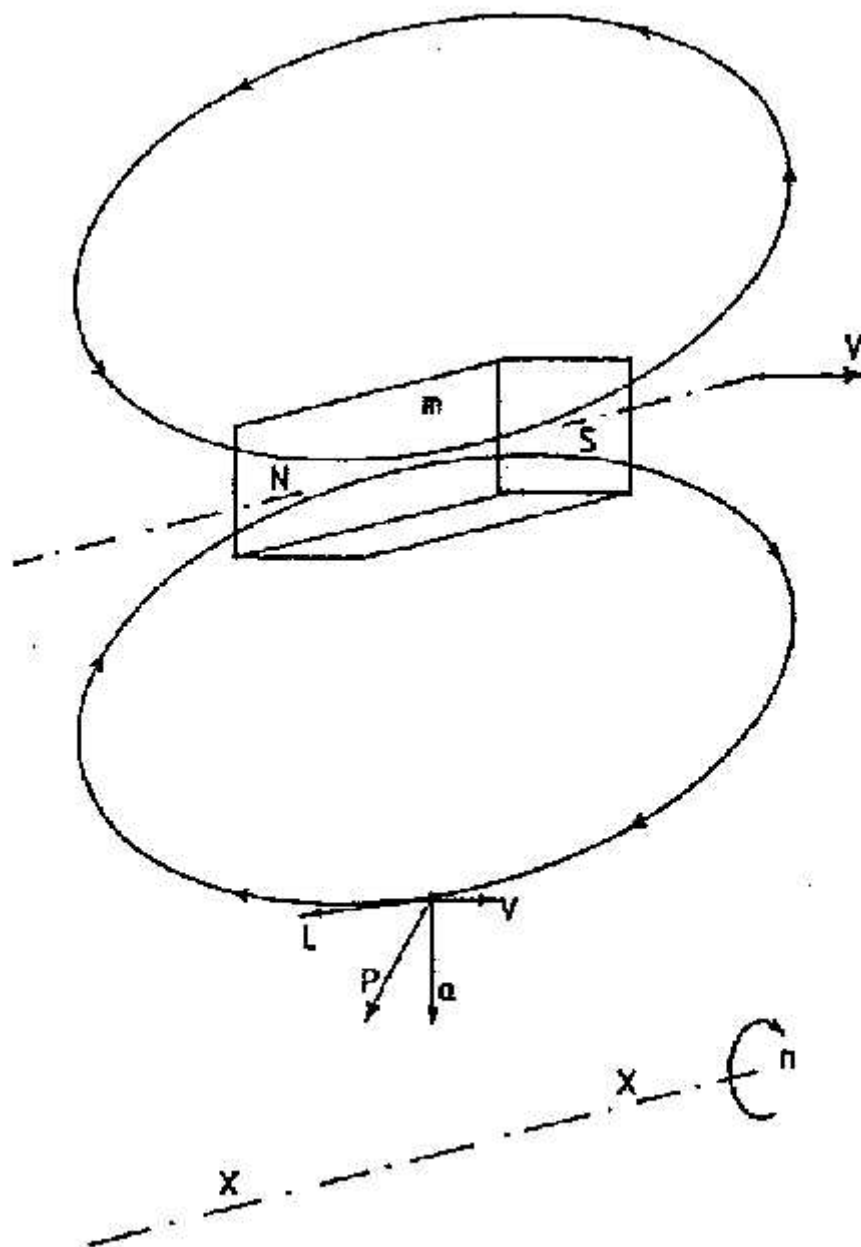

Fig. LA0. A diagram that shows the direction of **an elementary Telekinetic Effect (P)** created by the spinning of a magnet "m" around the axis "x-x". For the situation shown on this diagram, this direction seems to be the vectorial sum of a centripetal acceleration (a), linear speed (V), and the local direction (L) of magnetic field force lines. However, the direction of the effect (P) reverses into a direction that is exactly opposite after the reversal of the direction "n" of the magnet's revolutions. Moreover, this direction also reverses, after the polarity of magnet "m" was reversed (i.e. after directing its pole "N" to the side where its pole "S" is now directed). The above shows that direction of the Telekinetic Effect (P) depends in a complex manner on the direction of vectors (V), (a) and (L), and does not represent only a vectorial sum of these.

(During the analysis of this diagram it should be noted, that because of my specialization in propulsion systems of flying vehicles, all my publications define "N" magnetic pole as the pole that prevails at the north geographic pole of Earth, or at the end of a magnetic needle pointed south - see also subsection G5.2).

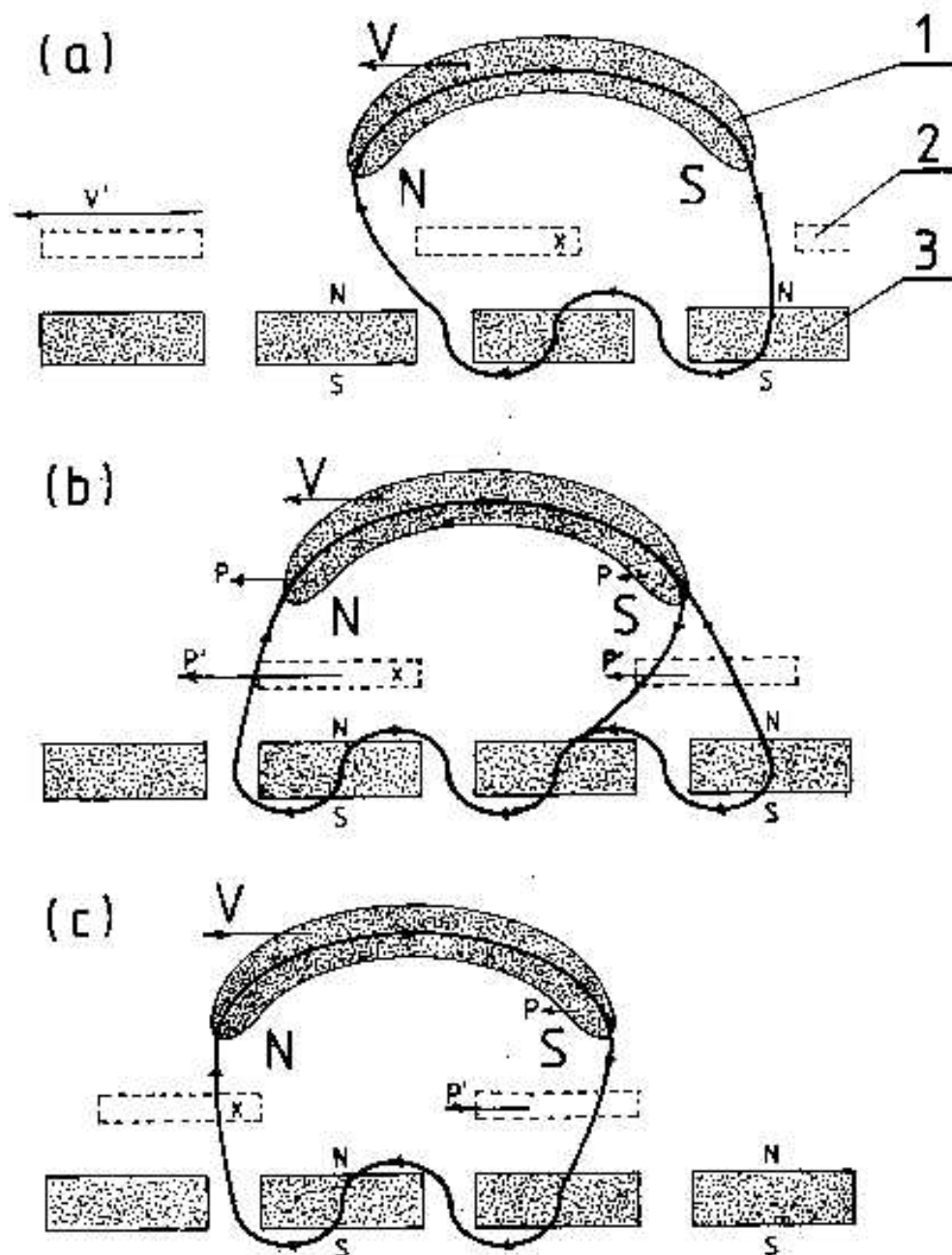

Fig. LA1. Three subsequent stages (marked a, b and c) of the **operation of the Johnson telekinetic motor**. A description of these stages is provided in the content of this monograph. The design and operation of the Johnson motor originally are published in article [1LA3] and also are subject to USA patent no 4,151,431. In the original version, this motor contains only two parts, i.e. the stator (3) and banana-shaped magnets of the Telekinetic Effect activator (1). Its efficiency slightly exceeds 100%, thus hardly sufficing to cover the friction of its relatively moving parts. Therefore, an additional part has been added to this diagram, i.e. the rotor (2) that does not exist in the original device. The purpose of this rotor is to absorb more efficiently the elementary drive P' of the Telekinetic Effect. The rotor (2) can also be used for the generation of an electric current (similarly to the rotor from the N-Machine) thus transforming the Johnson motor into a telekinetic free energy device.

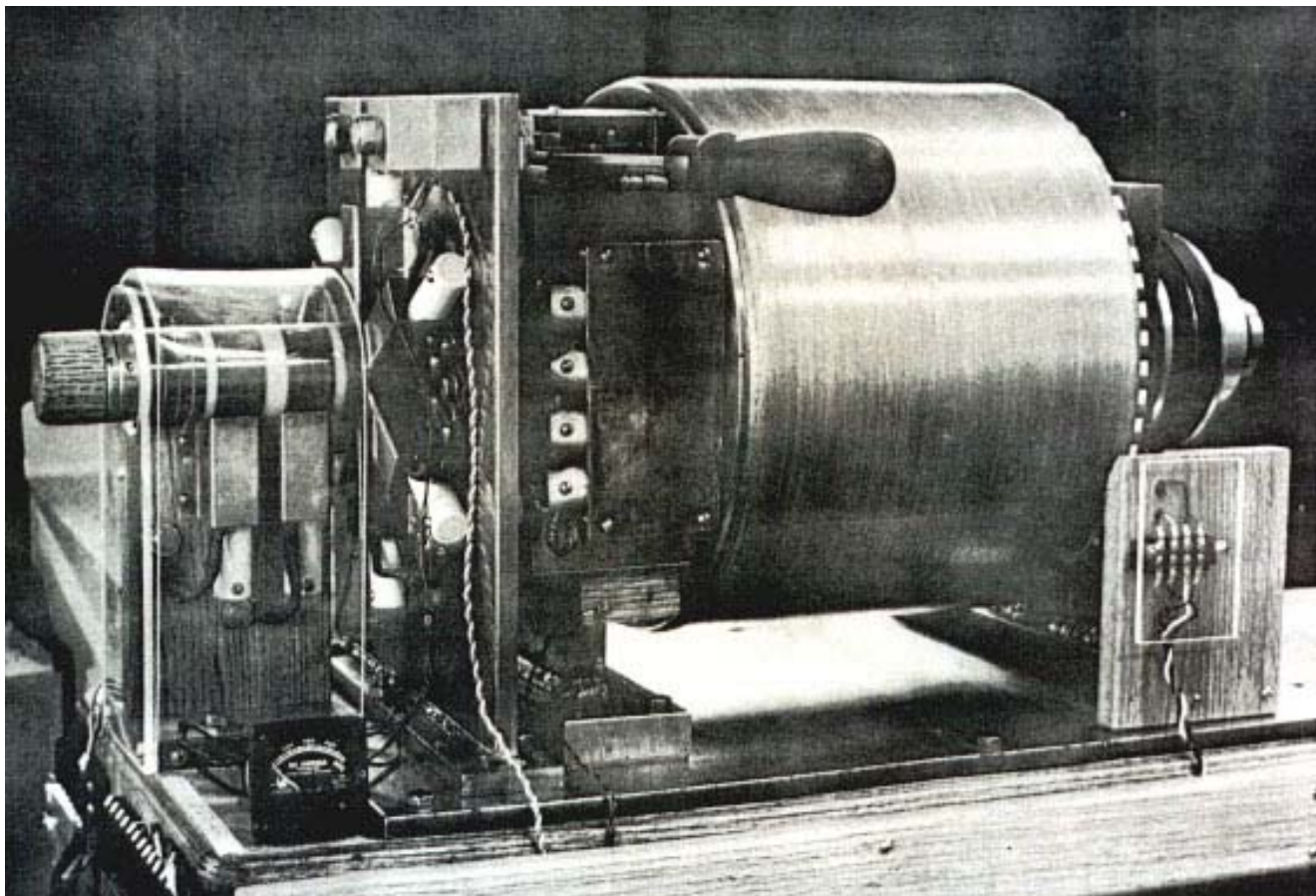

Fig. LA2. A photograph of the operational prototype of a telekinetic generator called the "**N-Machine**". This generator was completed by Bruce DePalma, and is being developed by the DePalma Energy Corporation (1187 Coast Village Road #1-163, Santa Barbara, CA 93108, USA) in cooperation with the Indian Nuclear Power Board, Karwar, India. The overall efficiency of the prototype of this generator, which is already operational, is 104.5%.

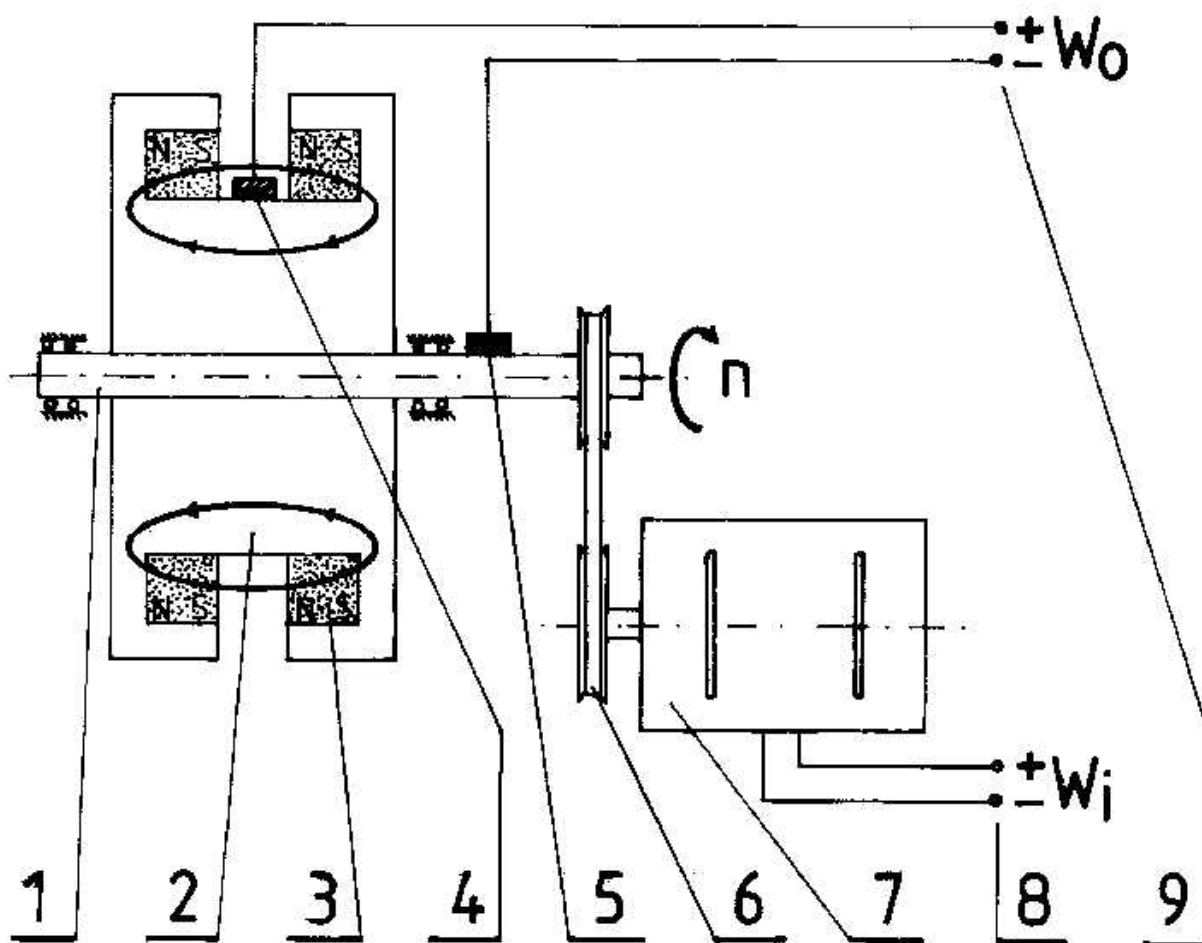

Fig. LA3. A diagram that illustrates the design and operation of the **N-Machine**. This DC generator consists of a shaft (1) made of conductive metal, on which a disc-shaped bronze rotor (2) is assembled. Inside the rotor permanent magnets (3) were placed which yield a field of about 6750 gauss. Brushes (4) and (5) collect the electric current which is produced and supply it to the output collector (9). The electricity supply to the propelling electric motor (7) is achieved via the input collector (8). This motor gives about $n=2600$ rev/min, which are transmitted through a belt transmission (6) and the conductive shaft (1) into the bronze rotor (2). The centripetal acceleration, caused by the spinning of this rotor, releases the Telekinetic Effect. The forces of this Effect act on free electrons present in the rotor (2), forcing them to flow towards the centre of rotation. The brush (5) touching the conductive shaft (1), and brush (4) touching the periphery of the rotor, collect the flow of current thus formed, and supply it for use.

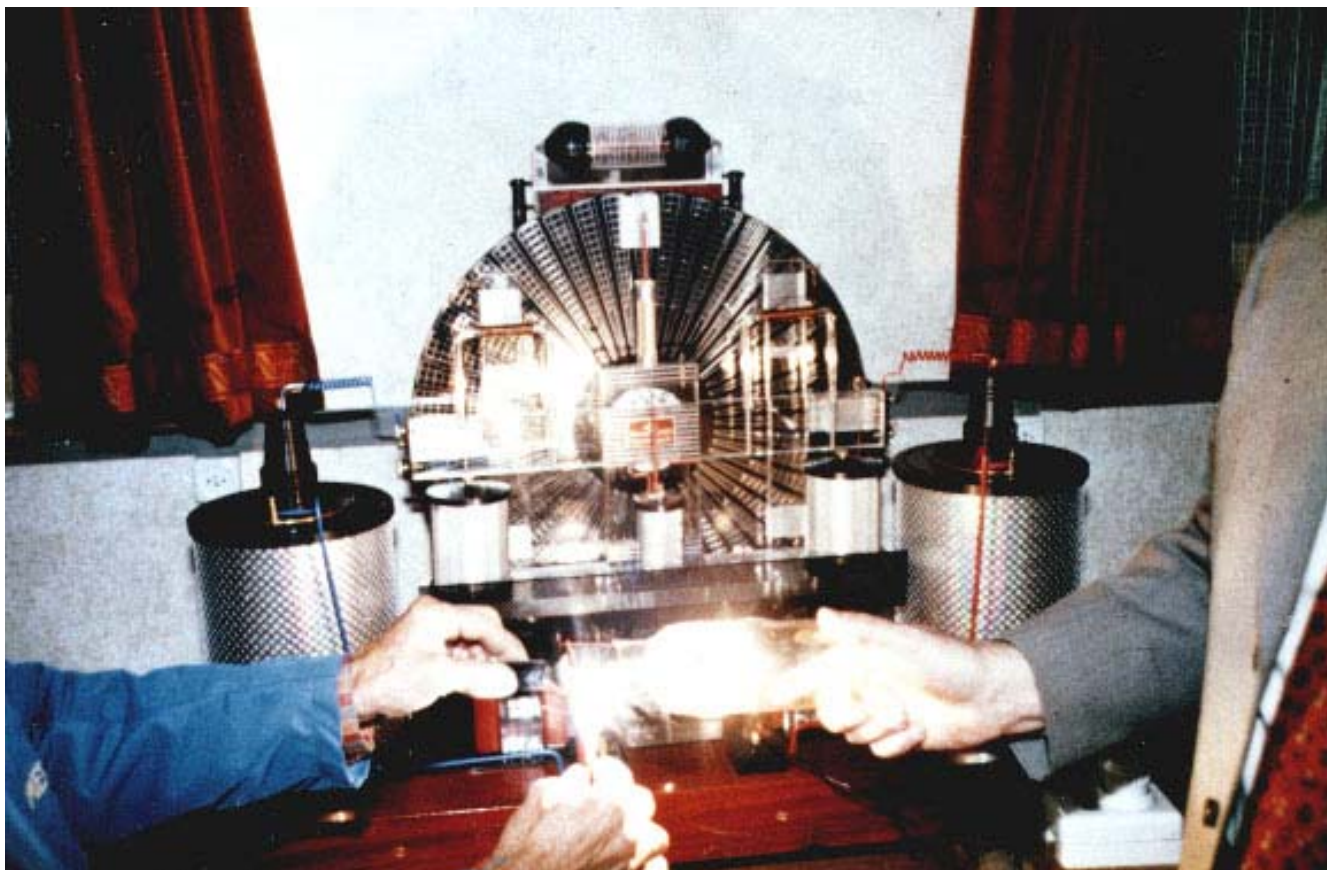

Fig. LA4. A photograph of the telekinetic free energy device named **INFLUENZMASCHINE** whose operation is based on the principles of Wimshurst's electrostatic machine. Video recordings presenting this machine in operation are available from METHERNITHA (CH-3517 Linden near Bern, Switzerland). Its brief description is contained in an article published in the West-German magazine Raum & Zeit, no 34, Juni/Juli 1988, page 94. The weight of the operational prototype shown above (called the Thesta-Distatica) of this machine is around 20 kg. Its discs rotate with speeds of between about 80 to 40 rev/min. Developers report that it produces up to 3 kW of electric power (3kW is the power of the first, short-duration impulse) with a fluctuating voltage of around 250 V. A by-product of its operation is the ionization of the surrounding air and the production of ozone. Except for quick starting by hand, the continuous operation of this machine is self-sustained by its spontaneous absorption of heat from the environment, and thus it does not require any external supply in fuel nor energy. The telekinetic influenzmaschine is the world's first free energy device which at the present stage of its development is ready for some limited commercial applications.

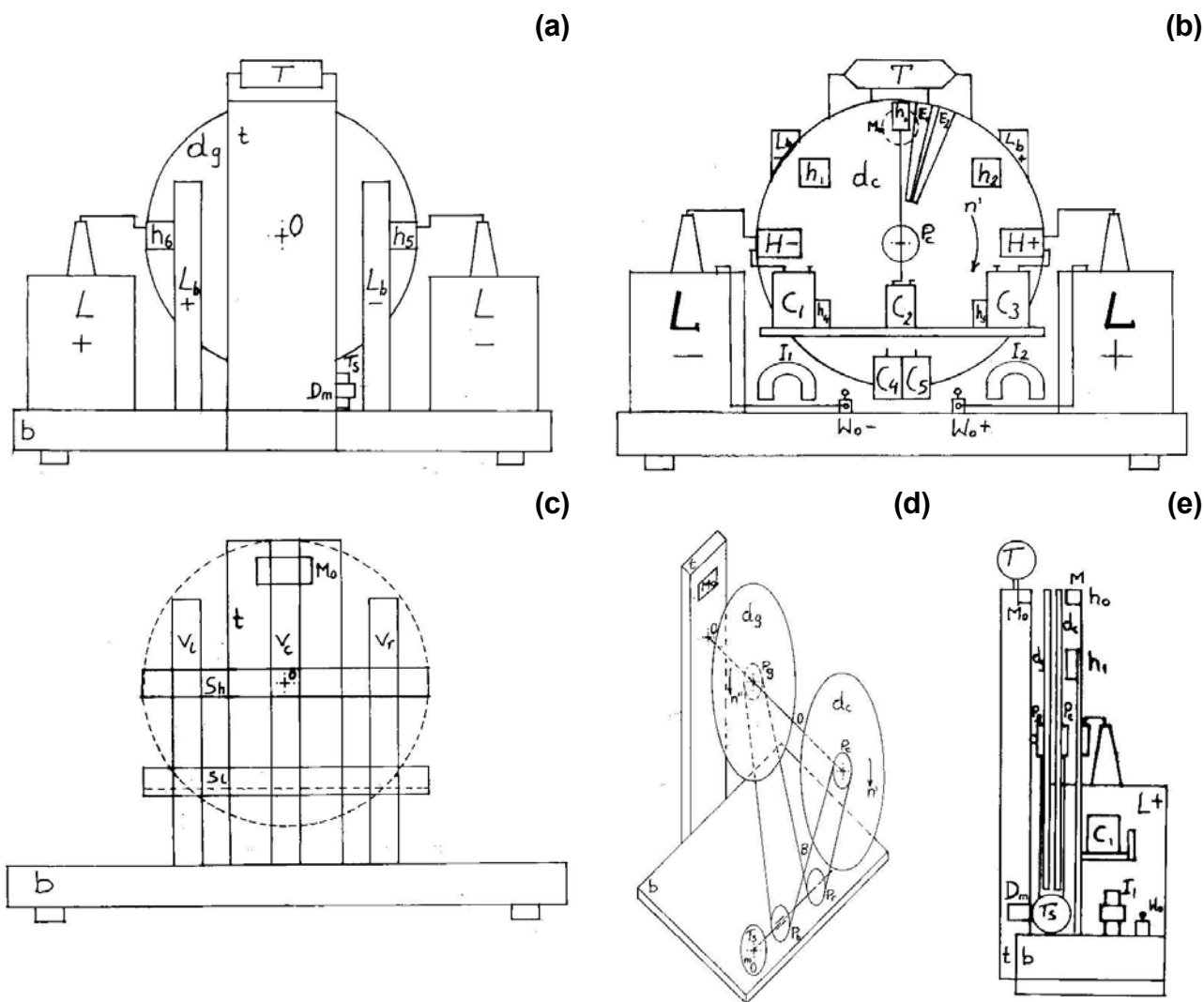

Fig. LA5. The mechanical design and main components of the telekinetic INFLUENZMASCHINE. Because my original drawings of this machine were lost, the above illustration represents only their reconstruction from my memory, supported with descriptions quoted in subsection LA2.3.3 that were saved in my personal computer. The dimensioning of drawing was done in an approximate manner, means without using any scale.

(a) Telekinetic Influenzmaschine shown in view from the back.

(b) The same telekinetic Influenzmaschine shown in the frontal view. The mutual positioning of subsequent components are shown. The components are marked with symbols described in subsection LA2.3.3.

(c) Carrier structure (frame) of the telekinetic Influenzmaschine. To this frame all components of the Influenzmaschine are assembled later.

(d) The kinetic diagram of Influenzmaschine. Components that produce rotational motion are illustrated. These include: frontal glass disk (d_c), back glass disk (d_g), belt pulley of the frontal disk (P_c), belt pulley of the back disk (P_g), belt (B), spindle (T_s), bearings pulley of spindle (P_b), fixed pulley of the spindle (P_r). Notice that the axel of rotation of the spindle (T_s) lies on the plane that is perpendicular to axis of rotation of both glass disks (d_c) and (d_g).

(e) The Influenzmaschine in side view that reveals the head of spindle (T_s) for showing of which the capacitor (L^-) that usually hides it was removed.

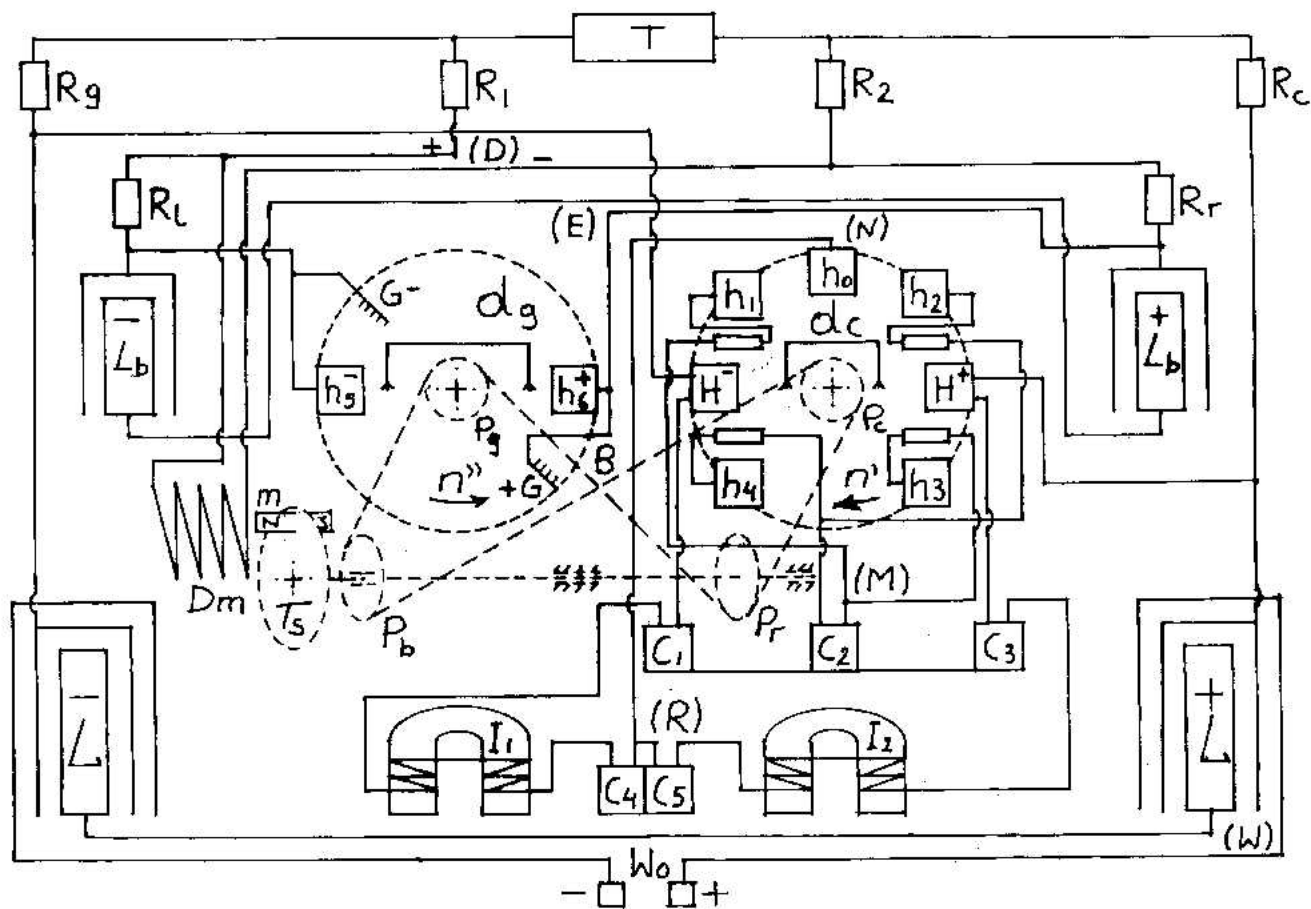

Fig. LA6. Electric diagram and circuitry of the telekinetic Influenzmaschine.

Copyright © 1998 by Prof. Dr Eng. Jan Pajak. The kinetic components (i.e. glass disks "ds" and "dg", spindle "Ts", and the belt "B") that are vital for the operation of electrical circuitry of this machine are marked with the broken line.

The telekinetic Influenzmaschine includes the following major components connected together in the manner shown on this diagram (see also Figures LA5 and LA4): tube (T), inductors (I_1) and (I_2), inductive capacitors (L), capacitors (C), dynamo-motor (Dm), resistors (R), inductive heads (H) and (h), magnets (m) and (Mo), and the electricity connecting plug (Wo). The tube (T) and inductors (I_1) and (I_2) are described in subsection LA2.4.

Because the original diagrams of this machine disappeared, the above electric diagram represents their reconstruction completed just from my memory and assisted only with descriptions provided in subsection LA2.3.3 that were saved in my personal computer. Therefore some of the connections or components shown on the above diagram in reality may run in a slightly different manner. If I manage to find my original notes, in future editions of the description of this machine I may improve further the above diagram.

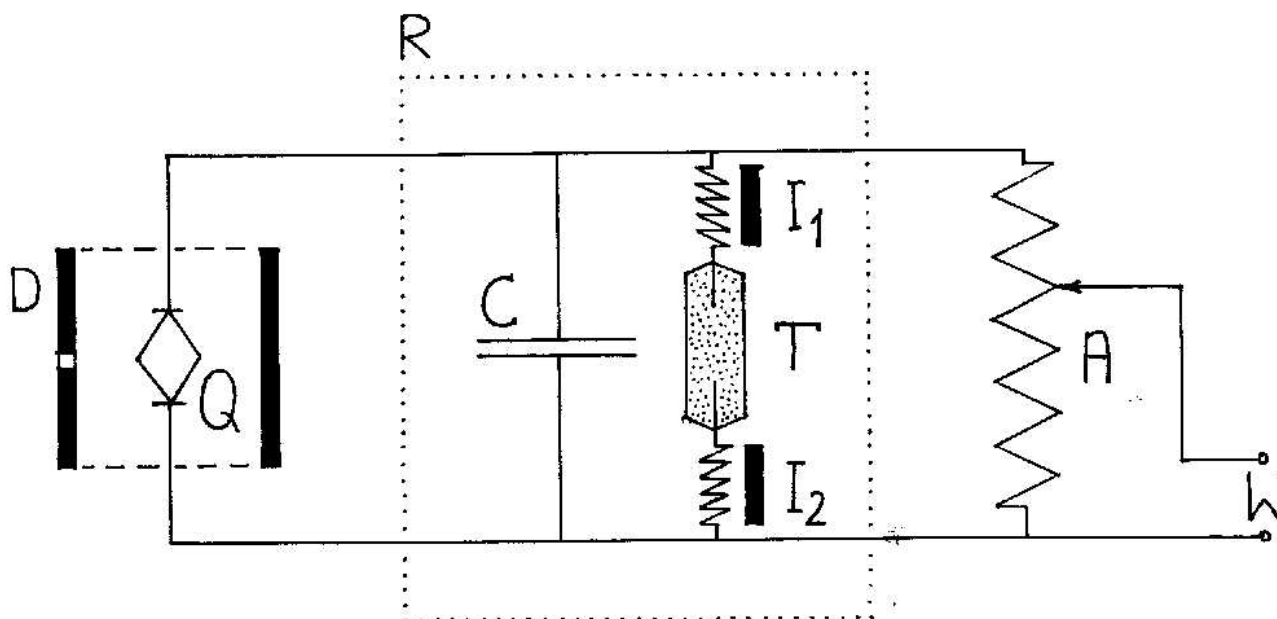

Fig. LA7. The illustration of a telekinetic battery. Such a battery is composed of several components that are relatively easy to manufacture. After appropriate connecting them together these components form a kind of cross between an autotransformer (A), an oscillatory circuit (R) and a rectifier (T). The important component of such a battery is its resonance cavity (D). On the example shown here this cavity is symbolised with a shape (D) empty inside and produced from aluminium plate that has a small inlet hole on one of the ends (practically this cavity can be formed on many different shapes, providing that these shapes concentrate telepathic vibrations in their focal point). In the focal point of this cavity (e.g. on the above example in its centre) a quartz crystal (Q) is suspended. The battery must also have a resonator (R), means an oscillatory circuit which is composed of combination of inductance (I) and capacitance (C). In order to increase the communicativeness of this diagram, the entire circuitry of the resonator is highlighted by marking it with dotted line. Further components of the telekinetic battery include: two deflecting inductors marked (I_1) and (I_2), tube (T), autotransformer or transformer (A), and the plug connector (W) for drawing the electricity produced by this battery. Apart from magnets of inductors (I_1) and (I_2), none other component of this battery is made of a ferromagnetic material or contains magnets.

The circuits of the operational telekinetic battery must fulfil several rigid operational conditions (see subsection LA2.4 for details). The most important out of these include: harmonic proportions of all components, "reciprocation" of its resonator (oscillatory circuit), the level of telekinetic reinforcement of its inductors, operational compatibility of the tube.

LA-61

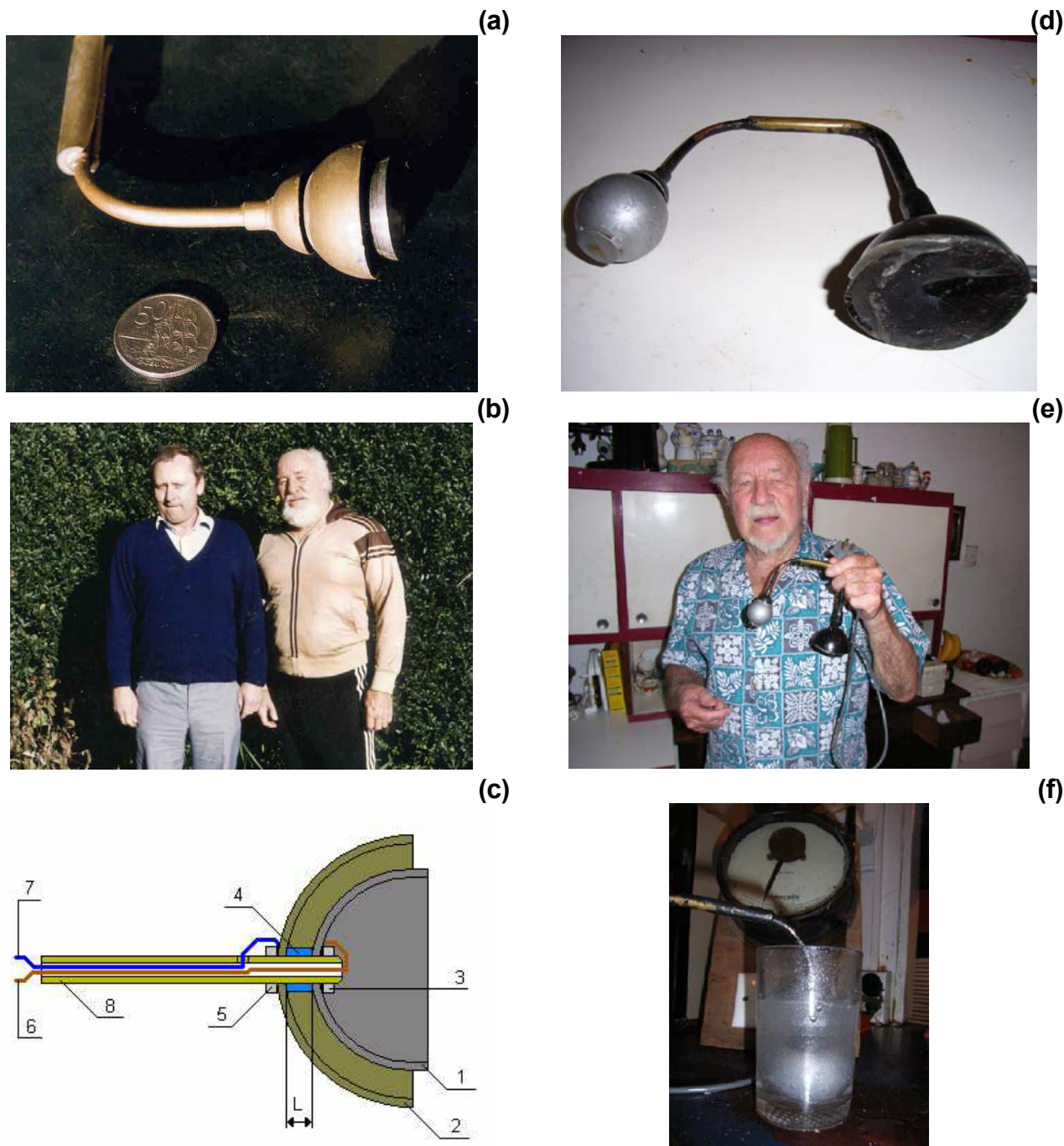

Fig. LA8. The telekinetic Immersion Heater invented during the World War Two by the New Zealand fighter pilot and musician named Peter Daysh Davey. This mechanically simple device generates many times more heat, than the amount of electrical energy that it consumes. Thus it has the energy efficiency of significantly exceeding 100%. It is probably one of the most simple free energy device in existence. It was proven in action and subjected to measurements by numerous scientists.

- (a) The heater which Mr Davey show me in 1990 – unfortunately it just burned (+ 32 mm coin).
- (b) Mr Peter Davey (this with the beard) and myself photographed in 1990.
- (c) The design and main components of the heater of Mr Davey (descriptions in the text).
- (d) The working heater which Mr Davey demonstrated to me in February 2008.
- (e) Mr Davey holding his sonic heater while demonstrating it to me in February 2008.
- (f) A glass of water boiled instantly by the sonic heater of Mr Davey in February 2008.

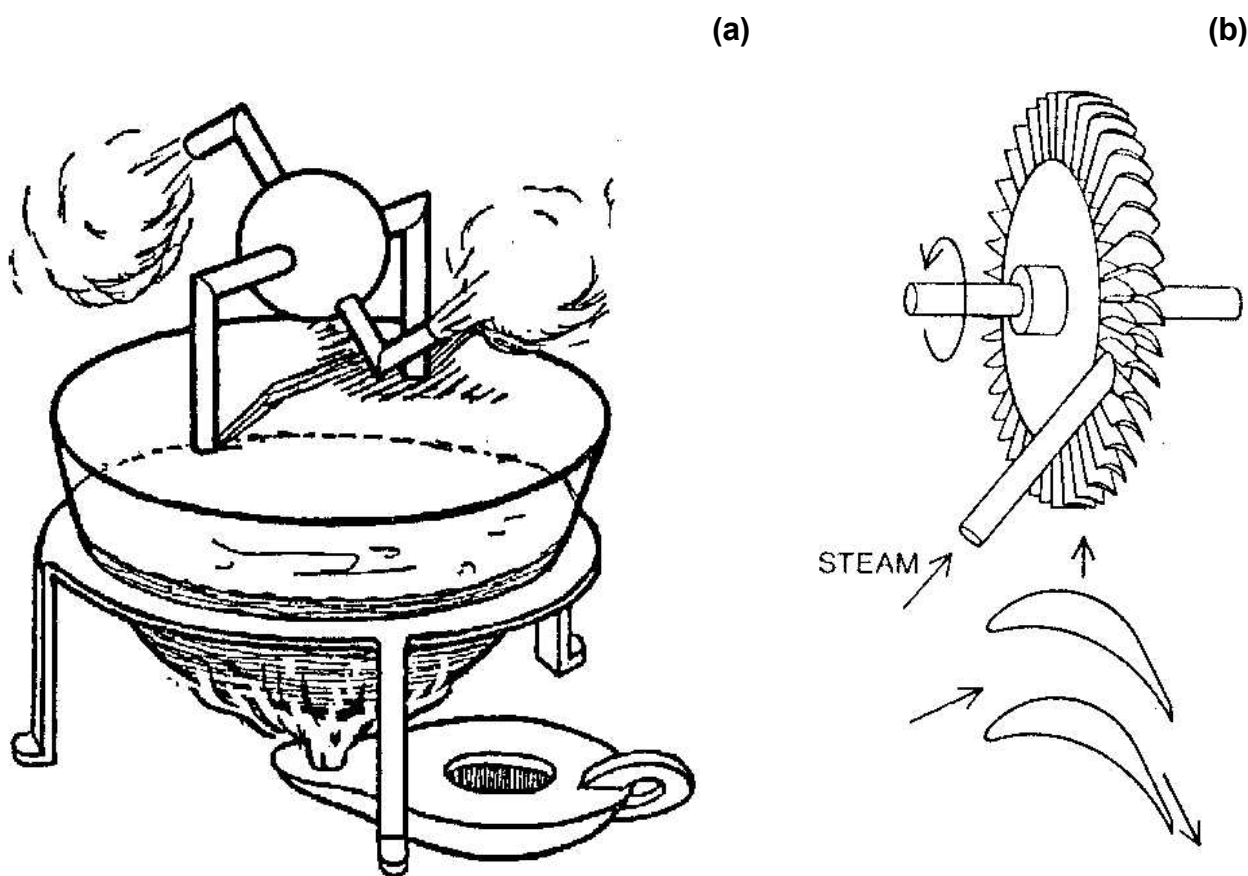

Fig. LA9. The evolution of a technical idea, from its conceptual formulation to a viable technological implementation. Around 130 B.C. Hero of Alexandria invented the aeolipile (eolipile), shown in part (a). It was as late as 1884 when an English inventor, Charles Algernon Parsons, built the first steam turbine in which the principles of the aeolipile are implemented efficiently enough to produce useful mechanical power - see part (b). The efficiency of current telekinetic devices is equivalent to that of the eolipile. So before these devices become commercially useful, their efficiency needs to be transformed into the equivalent of that of steam turbines.

(a) The operation of the eolipile. It utilizes only jets of expanding steam that escape from two hollow arms, thus not utilizing the energy of pressure, impact, and temperature of the steam. Because of the inefficient conversion of energy carried in the escaping steam, this device produces mechanical energy that scarcely covers its own friction. Therefore, the rotation of the eolipile (similar to the motion of current telekinetic devices) only demonstrates the correctness of its principles, but cannot supply any useful power.

(b) Principles underlying the operation of steam turbines, demonstrated with only one of several cascade rotors. The blades of these rotors deflect the jet of steam, intercepting its inertial impact. In addition, as the steam passes between the blades, it expands and accelerates, propelling them with reaction forces similar to those formed in a rocket outlet. After the steam leaves a particular rotor, it is intercepted by the fixed blades of a stator and redirected to strike the next rotor. Thus, such a cascade conversion of the steam's energy in turbines is efficient enough to produce an excess of mechanical power that can be utilized.

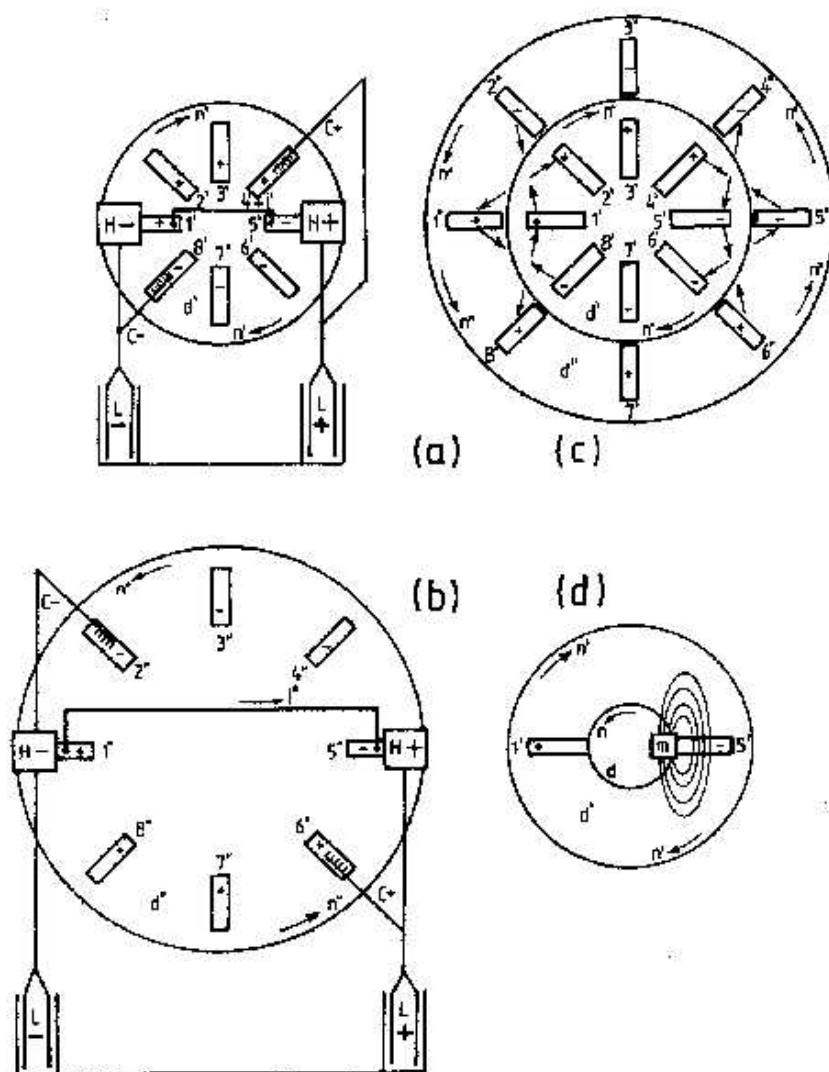

Fig. LA10. The operation of the telekinetic influenzmaschine with two discs, which produces a DC current, reconstructed (or rather: re-invented) by myself. Explanations of this operation are provided in the content of this monograph. Symbols: C+, C- = collecting combs connected to the inner coating of Leyden jars; d = a small disc containing a magnet (m) that is used for the release of the Telekinetic Effect; d' = front disc made of a good electric insulator (e.g. glass); d'' = back disc identical to the front (d') one (in order to increase the communicativeness of this illustration this back disc is shown as having a larger diameter); H-, H+ = square induction heads that electrostatically influence the machine's electrodes; i', i'' = motionless bridging conductors; L+, L- = two Leyden jars which collect electrostatic charges from the electrodes of both discs (users are plugged to the wires that are connected to the inner coatings of these jars); n, n', n'' = direction of the rotation of each disc; 1, 2, ..., 8 = numbers of the subsequent electrodes (this drawing shows 8 electrodes only, but each disc of the telekinetic influenzmaschine houses 48 separate electrodes); +, - = positive and negative electrostatic charges; ', '' = indexes that assign particular symbols to the front (d') or back (d'') discs. (The above diagram is also shown as Fig. 8 in monograph [6/2], and as Fig. B10 in monograph [1e].)

- (a) Principles of the inducing electrostatic charges in the front disc.
- (b) Principles of the inducing electrostatic charges in the back disc.
- (c) The operation of an electrostatic induction motor that sustains the continuous rotations of disks of the telekinetic influenzmaschine.
- (d) Telekinetic generation of charges that restores their loss from friction.

UTILISATION OF WHIRLS OF COUNTER-MATTER

The Telekinetic Effect is a phenomenon which manifests itself in a wide range of separate disciplines, devices, and applications. Actually it appears in every situation where some kind of magnetic field is subjected to acceleration or deceleration. Only this monograph discusses successful utilizations of this effect, amongst others, in:

#1. Various technical devices, such as propelling devices, electricity generators, telekinetisation devices, etc.

#2. In various phenomena that are based on this effect and that are utilised by our civilisation in chemistry, medicine, farming, etc.

#3. In pure manifestations appearing in paranormal phenomena described in subsections H1.2 and LB3. It includes e.g. levitation, psychokinesis, bending of water divining rods, etc.

#4. Many previously unexplained behaviours of elementary particles. For example in the tunnel effect.

#5. In various anomalies noted in physics of rigid bodies. For example in directional steadiness of gyroscopes. Until the discovery of the Telekinetic Effect this steadiness could be described only in category of its effects not in category of the mechanism which causes it. But the Telekinetic Effect explains that this steadiness results from the generation of the effect in gyroscopes by centrifugal acceleration caused by their spinning motion.

#6. In various inconsistencies of electrical phenomena. As an example consider the Faraday disc which was the first generator of electricity on Earth (now it is utilized in N-Machine described in subsection LA2.2).

#7. Noticed recently phenomena of the loss of weight by various substances or objects which are subjected to the action of accelerated magnetic field which generates the Telekinetic Effect. Examples of such substances are discussed in subsection LB1.

Of course, apart from the above, there are numerous other manifestations and applications of this effect, which are not possible to be accommodated in such brief subsection.

Through revealing all these, I am trying to realise that the Telekinetic Effect is one of the most primary phenomena of nature, since it manifests itself in so many ways, areas and applications. Yet, orthodox scientists, who present to the society each such a discipline, application, and invention, believe so-far that they deal with just a conjunction of favourable circumstances, which is local, unique for their area, and which by a coincidence provides them with the principles they utilize. Because of such an attitude, this omnipresent and important effect remained unnoticed to the orthodox science for so long. Of course, as the result it also remained unharvested. It is about a time that we change the way we think about this reversal of friction. By recognizing this new, omnipresent, and important phenomenon, we should make a start on implementing it for the benefit of our civilization.

The Telekinetic Effect rules also phenomena on Earth, which so-far were described by totally different mechanisms. Their example is **weather**. Here are descriptions of such further areas and phenomena, in which the Telekinetic Effect may find surprising applications in the not-too-distant future.

LB1. Directing of winds on Earth

As it turns out, our planet is penetrated in all directions by colossal whirls of counter-matter. These whirls form closed circuits of circulation and have toroidal shape similar to "donuts". The diameter of paths along which counter-matter spins, may in such whirls exceed

over thousand of kilometres. In turn the outer circumference of a toroid or "donut", along which such whirls of counter-matter form closed circuits, may exceed many times the diameter of Earth. These whirls have a shape and a structure that is described more comprehensively in subsection H4.2. In general these whirls are subdivided into two categories, namely into "decompression" and "compression" whirls. In both these categories they display opposite attributes. **Decompression whirls** cause the appearance of low pressure areas inside of their core. In turn **compression whirls** cause that the air inside of them always is compressed and forms areas of high pressure. All these whirls enter into the volume of our planet in one point of the surface, the location of which continually changes. After entering the Earth on one of hemispheres, they penetrate through the interior of Earth in order to emerge at the other hemisphere of Earth. Then, after encircling a huge arch in free space, they return back to the point in which they entered our planet.

Because of the Telekinetic Effect, which is formed by the counter-matter of these huge whirls, their unique attribute is, that in the area where they run through Earth's atmosphere, they form spinning winds. These winds usually are called "cyclones" and "anticyclones". Actually all winds that blow on Earth, in reality are formed by particles of the air which follow the motion of counter-matter from the counter-world. In turn the circular winds, which always blow along closed circuits and which appear on Earth in the greatest number, are formed just by such colossal whirls of counter-matter. Because of this, such circular winds on Earth can be subdivided into two classes, which correspond to the above two different categories of such whirls of counter-matter in the shape of a toroid or a "donut". These are:

#1. Winds that spin around an area of **low atmospheric pressure**. These on the Northern Hemisphere are always blowing in the counter-clockwise direction. Notice that the hypothetical **reference clock**, by which their direction of rotation is defined, must be lying on the surface of the Earth, while its dial is pointed upward. But on the Southern Hemisphere these are blowing in the clockwise direction.

Winds that blow around area of low atmospheric pressure have the tendency to decrease their circumference of rotation, and thus to reach **huge velocities** of rotational motion. On the Northern Hemisphere they form destructive "cyclones" that rotate counter-clockwise. On the Southern Hemisphere they form equivalents of cyclones which rotate in the clockwise direction.

Because of the low pressure that prevails in their area of rotation, these whirls of counter-matter always stimulate the condensation of water vapours. Thus they always are accompanied by **rainfalls**. Their coming to a given area always is an indication of a bad weather arriving there.

A special version of these winds are **tornadoes**. These tornadoes are also formed by such decompressing whirls of counter matter, which in their interior maintain area of low pressure. Strings of spinning counter-matter experience in them temporary shrinking to the diameter of just only several hundred meters, or even less. In such whirls of spinning counter-matter with so small diameters of spinning, the created Telekinetic Effect is so powerful, that it is able to move not only particles of the air, but even entire trucks and buildings. Tornadoes, similarly like cyclones, are spinning in the counter-clockwise direction on the northern hemisphere - i.e. where they enter the ground. In turn on the Southern Hemisphere (e.g. in New Zealand and Australia), they spin in the clockwise direction.

#2. Winds that rotate around an area of **high atmospheric pressure**. These are formed by gigantic whirls of counter-matter that in the Northern Hemisphere are spinning in the clockwise direction. In turn on the Southern Hemisphere they are spinning in the counter-clockwise direction. (Notice that the reference clock in relationship to which the direction of their rotation is defined, must always have a dial pointing upwards.) These kinds of winds always are accompanied by a perfect weather and cloudless sky. The speed of these winds is also rather low and relatively constant.

The origin of all circulating winds on Earth from whirls of counter-matter has one significant consequence. Namely it allows that people may control winds. In turn by controlling these winds, people may control weather. The only thing that is needed in order to effectively

control the location and the direction of winds blowing, is to send a large Magnocraft in the centre of such a whirl of counter-matter, synchronise the whirl of the magnetic field formed by such a Magnocraft with this whirl of the counter-matter, and then shift slowly the Magnocraft. The whirl of the counter matter will follow the whirling field of the Magnocraft. In turn the dislocation of this whirl of counter-matter will cause the motion of winds which are induced on Earth by this whirl.

It is worth to notice, that UFOonauts who occupy Earth control in this way winds and weather on Earth since the beginning of times. With the aid of such control they accomplished many of their evil goals - as I described this in subsection A3. After all, already mythology of ancient Greece describes the control of winds and weather by "gods" - means by ancient equivalents of present UFOonauts.

The above is worth complementing with the information, that ocean currents, and linear winds from the upper atmosphere of the "jet stream" type, are also caused by whirls and streams of counter-matter. So all of them can be controlled with the use of Magnocraft of large sizes. Furthermore, as I explained this in subsection O6, whirling turbulence of the air which destroy our aeroplanes, actually are also induced by whirls of counter-matter formed by invisible UFO vehicles.

* * *

I am fully aware, the above my explanations for the counter-material mechanism of formation of winds and weather on Earth, is going to induce a wide criticism of entire orthodox sciences. After all, on Earth there are huge numbers of people who earn for their living due to these traditional explanations of mechanism of winds and weather. These people are going to criticise vigorously what I wrote above. Fortunately for me, the truth always can be proven. Therefore if a real mechanism of winds and weather is as I described it above, then there is a manner to prove (or disprove) the merit of it. This manner depends on the fact, that each such "decompressing" whirl of counter-matter, that e.g. in the Northern Hemisphere forms a destructive cyclone or tornado, after entering under ground must appear approximately on the opposite side of our planet, and from there a similar "decompressing" whirl which also induces a similar type of winds. This means that if in a given moment of time someone photograph our planet around, then there must exist on it an even number of such "decompressing" whirls and circulatory winds that are formed by them. Because all such low pressure systems of winds form swirlings of clouds that can be visible on satellite photographs, in present times their number should be possible to be counted empirically.

Similarly must be with "compressing" whirls. Their entire number on Earth also must be even. However, because they do not form clear swirlings of clouds - but only areas of clear sky, the counting of their complete number may turn out to be more difficult.

There is one problem with the above proof. It depends on the fact, that whirls of counter-matter do not have a consistent cross section of whirling along the entire circumference of the toroid that they form. In some areas they may be decompressed more, in other areas - less. This means that in one place of the circumference of their toroid, they may form e.g. powerful tornado, while on the opposite side of Earth they may be just a large area of low pressure around which winds circulate very slow. So during such proving it may be difficult to determine which circulations from one hemisphere are other ends of similar circulations from opposite hemisphere. But their total number in the scale of the entire globe must always be an even number.

LB2. Technological formation of clouds and fogs

As it turns out, the Telekinetic Effect allows to technically form clouds and fogs. Appropriately selected frequencies of telekinetic field oscillations allow for the immediate condensation of moisture contained in the air, and for the formation of phenomena, which at high altitudes are called "clouds", while at the ground level are called "fogs". (A bit more about telekinetic phenomena and mechanisms connected with chemical catalysis, formation of

clouds, or condensation of steam, is explained in chapter LB.) This in turn allows that telekinetic vehicles of the second generation, such as Magnocraft or UFOs, are capable to form clouds and fogs on each wish of their crews, and also are capable of cause rain falls in every area that UFO crews may wish.

UFO-nauts that occupy Earth from the beginning of time utilise in their evil activities on Earth this capability of UFO vehicles to form clouds, fogs, and to cause rain falls. For example, when a well visible UFO vehicle hovers during a daytime above an area of Earth, it always creates a large cloud around itself to hide from the view humans. In almost every case when UFO-nauts intend to land their vehicle in a visible mode and in an open area, they also form a local cloud of fog around the area of their landing to remain unnoticed for people. They form fog in cases of abductions of people during daylight and from public areas that could be seen by other witnesses. Actually a significant proportion of reports from UFO abductions mentions fogs and rainfalls that were artificially induced by UFOs. Various descriptions of the formation of clouds, fogs, and rain falls by imperfect "gods" that correspond to present UFO-nauts, are also present in ancient myths.

Chapter LC:

MAGNOCRAFT OF THE SECOND GENERATION (telekinetic vehicle)

In chapter B of this series of monographs a law discovered by myself and called a "Periodic Principle" was described. This Principle reveals that our progress in the means of transportation will not be limited to building only the Magnocraft and to constructing various propelling devices derived from this vehicle (as described in chapters C to F). It also indicates that after the Magnocraft two even more advanced vehicles will be built on Earth. The propulsion of these vehicles will similarly utilize the circulation of magnetic field force lines - see two highest rows in Table B1. But their operation will be based on two phenomena not yet completely worked out by Earth's science. These are the magnetic equivalents to inertia and to internal energy. Although these two phenomena are already well known for all the physical substances, for the magnetic fields at the present level of knowledge their meaning can only be deduced theoretically with the use of my theory called the Concept of Dipolar Gravity which is described in chapters H and I (volumes 4 and 5) of this series of monographs, and further elaborated in monographs [1e], [2e], [3], [5e], [6], [7], and [8] (some of the findings of this theory were also published in my article **[1LC]** entitled "Gravitation als Dipolare Felder", published in the West-German Journal Raum & Zeit, Nr. 34, Juni/Juli 1988, pages 57 to 69). According to this theory the magnetic equivalent to inertia is the "Telekinetic Effect" described in more details in subsection H6.1 from volume 4, whereas the magnetic equivalent to internal energy is the "magnetic concept of time" stemming from the Concept of Dipolar Gravity - for more details see subsection H9.1 from volume 4 of this series of monographs.

These two advanced magnetic phenomena, i.e. the Telekinetic Effect and the elapse of time according to the magnetic concept of time, can be utilized for propelling purposes. The utilization of the Telekinetic Effect becomes reality when our civilization develops devices capable of causing a telekinetic motion. There are two kinds of motion that a technological version of telekinesis can produce, i.e. relative and absolute (see subsection B2). All propelling devices that employ technological telekinesis to produce a relative motion are called here "telekinetic motors", but all such devices producing an absolute motion are called "telekinetic propulsors". In this monograph the term "telekinetic vehicle" is defined as a vehicle that utilizes an absolute version of telekinetic motion for the purposes of transportation. Thus the name telekinetic propulsors originates from this term. An advanced flying vehicle which utilizes telekinetic propulsors is called here the Magnocraft of the Second Generation, or the "Telekinetic Vehicle". Its description is contained in this chapter LC, starting from subsection LC2. (Telekinetic motors are described in subsection LA2.1, and in a separate monograph [6].)

The utilization of the magnetic concept of time become reality when our civilization further improves the telekinetic propulsors and adds them a capability to alter the natural elapse of time. The vehicles received in that manner will be able to fly and also to alter the natural elapse of time. These extraordinary vehicles will be called the Magnocraft of the Third Generation or "Time Vehicles". Their descriptions are provided in the next chapter N.

The aim of this volume is to provide theoretical foundations which explain the unique phenomena and technical details characteristic for the two most advanced generations of the Magnocraft, i.e. for the Magnocraft of the Second and Third Generations.

LC1. Principles of operation, and devices which allow the implementation, for magnetic propulsion systems of the future (reminder)

LC1.1. The Cyclic Principle which foretells the construction of three generations of magnetic propulsion systems

Do you remember how subsequent chemical elements were discovered. Well, initially chemists kept discovering them by chances. Then a great Russian scientist and thinker was born, named Dmitry Ivanovich **Mendeleev** (1834 - 1907). He discovered that subsequent elements fit nicely into a tidy table, which we call the **Periodic Table of Elements**. When this table was created, further discoveries of chemical elements become intentional. This is because the Mendeleev's Table was telling people which chemical elements still remain undiscovered, and what their properties are. So by following hints that result from this table, remaining chemical elements could be discovered and described quite quickly and effectively.

As it turns out exactly the same happens with inventions of new propulsion systems and new propelling devices. Initially these were invented by chances. And so in this manner James Watt (1736 - 1819) invented a steam engine, while Rudolf Diesel (1858 - 1913) invented a diesel engine. But in 1972 an equivalent of the Mendeleev's Table was discovered also for propulsion systems. This equivalent takes a shape of the **Periodic Table of Propulsion Systems** shown and explained comprehensively in chapters B and L (volumes 2 and 10) of this series of monographs. The general principle on which this table was constructed is called the "Cyclic Principle" – see descriptions of this principle in subsection B1 from volume 2 of this series of monographs. **In exactly the same way as the Periodic Table of elements allows to discover intentionally all subsequent chemical elements, also the Periodic Table of Propulsion Systems allows to invent intentionally new propelling devices and new vehicles.** This is because it puts all possible propelling devices into a tidy order, thus allowing to reason about their future design, principles of operation, and displayed properties. So this new table opens for us the doors for an easy and effective inventing of all propelling devices that humanity is going to build in the future.

The complete presentation of the "Cyclic Principle", and also the "Periodic Table of Propulsion Systems" which results from this Cyclic Principle, are provided in chapter B (volume 2) of this series of monographs. Thus readers who are interested in learning more about these "keys to inventions" are recommended to read chapter B. Here I only try to remind with the aid of this principle and table, that all devices and propulsion systems described in this volume are actually products of this principle and table, plus (of course) products of a long, systematic, laborious, and hard scientific research which turned clues resulting from this principle and table into principles of operation, physical designs, and finally descriptions from this monograph.

The most promising out of these next propulsion systems indicated by the "Cyclic Principle" that they still await their completion, turned out to be the "Magnocraft". Magnocraft is a discoidal space vehicle that moves silently because it is propelled with a pulsating magnetic field. In the light of the "Periodic Table of Propulsion Systems", Magnocraft is a "brother", or a mirror reflection, or a symmetrical analogy, to electric motors. Actually the Cyclic Principle and the Periodic Table of Propulsion Systems which results from the Cyclic Principle, indicated exactly to us how the Magnocraft is going to look like, and how it is going to operate. As it turns out, the design and principles of operation of the Magnocraft are symmetrical analogy to the design and to principles of operation of asynchronous electric motors. Only that instead of a stator, that is used by asynchronous electric motors, the Magnocraft uses a natural magnetic field of Earth, Sun, or Galaxy, for the same purpose. Of course, to interact effectively with these natural fields, the Magnocraft needs an extremely powerful propelling device, which is called the "Oscillatory Chamber". The design and operation of the Oscillatory Chamber is presented briefly in next subsection LC1.2, while it is explained in details in chapter F (volume 2) devoted entirely to the description of this propelling device. In turn the design and operation of the Magnocraft of the first generation is presented briefly in further subsection LC1.3, while it is explained in details in chapter G devoted entirely to the description of this space vehicle. According to my "Cyclic Table",

Magnocraft and its Oscillatory Chamber should be completed on Earth not later than by the year 2036 - see Table B1 from volume 2 of this series of monographs.

LC1.2. The Oscillatory Chamber – means a futuristic magnetic propelling device

An "**oscillatory chamber**" is a device of my own invention, for the production of extremely powerful magnetic fields. Thus it would be appropriate to state, that it is a kind of a super powerful "magnet" (i.e. the magnet so powerful, that such a chamber on its own is capable to repel itself from the Earth's magnetic field and to ascend in space, simply due to a repulsive interaction with the Earth's magnetic field). The operation of this chamber is based on a completely new principle, previously unknown on Earth, in details described in chapter C of this monograph, and also in English monographs [1e] and [2e]. This chamber usually takes the shape of a transparent cubical box, empty inside. Along side walls of this box oscillatory electrical sparks are maintained, which force the streams of sparks to rotate along peripherals of a square. The square rotation of this electrical sparks forms a powerful magnetic field. Thus a single oscillatory chamber is a kind of extremely powerful magnet, that is able to lift itself (together with a heavy structure of a space vehicle attached to it) exclusively due to the repulsion from the magnetic field of Earth, Planets, Sun, or Galaxy. In order for this lifting to be possible, the magnetic output from the oscillatory chamber must exceed the value, that is expressed through a magnetic constant called the "**starting flux**". This starting flux is defined as "the smallest output from any source of magnetic field, related to the unit of weight of this source, which after being oriented repulsively towards Earth's magnetic field, causes the overcoming of gravity pull and the ascend of this source of field into space". The value of the starting flux is calculated in subsection F5.1 of this monograph. It is also calculated in English monographs [1e], [2e], and Polish [1/3]. For the area of Poland it amounts to $F_s=3.45$ [Wb/kg].

The output from a single oscillatory chamber would be quite difficult to control. Therefore, for the purpose of better controllability, the Magnocraft uses special arrangements of oscillatory chambers, called "**twin-chamber capsules**" (such a capsule is shown in part (c) of Figure LC1, while described in subsection F7.1 of this monograph and in subsection F6.1 of monographs [2e] and [1e]). Such a capsule is composed of a larger outer (O) oscillatory chamber, inside of which a smaller inner (I) oscillatory chamber is freely floating. Magnetic poles N/S of the inner chamber (I) are reversed in relation to magnetic poles of the outer chamber (O), so that outputs from both these chambers mutually subtract from each other. In the result, the part of the output (C) from the chamber with the larger output, is bend back and circulated as input directly to the smaller chamber, thus forming the so-called "circulating flux" (C) that never leaves the interior of the twin-chamber capsule. Only the excess of the output from the chamber with larger yield is forwarded to the environment, thus forming the so-called "resultant flux" (R) that represents the useful output from this capsule. The division of the magnetic energy contained in such a capsule into the "resultant flux" (R), and the "circulating flux" (C), allows the extremely fast and effective control over the output from such a capsule, without the need to change the amount of energy contained in such a capsule. This control depends on the simple change of mutual proportions between the flux (C) that is circulated inside of such a capsule, and the flux (R) that is directed to the environment from this capsule. Thus, there is a possibility to control the operation of this capsule, so that to the outside is directed no output at all (this happens when the entire magnetic field produced by both chambers of such a capsule is trapped in the circulating flux), or to cause that the entire magnetic energy of the capsule is directed outside. It is also possible to accomplish fluently any state between these two extremes. In turn this effective control over the output from such a capsule, allows to precisely control the flight of the vehicle that is propelled by the resultant magnetic flux (R) directed by this capsule to the environment.

Unfortunately, the twin-chamber capsule is rather resistant to accept control signals. After all, such control signals must be forwarded without any wire to the smaller oscillatory chamber that freely floats inside of a very powerful stream of magnetic energy. Therefore, the

construction of this capsule requires rather advanced technology. Thus, in the first stage of constructing of Magnocraft, instead of this capsule, much simpler propelling device is going to be used, which also allows the effective control over magnetic output that is yield to the environment. This simpler device is called the "**spider configuration**". The description of it is contained in subsection C7.2 of this monograph, and in chapter F of monographs [2e] and [1e]. In the first period of production of Magnocraft, that is more exactly described in subsection LC6, these vehicles are going to use such much simpler for control prototype spider configuration (instead of the difficult to control, and technically very advanced twin-chamber capsule).

In the design of the Magnocraft, all "twin-chamber capsules" (or "spider configurations") are assembled into spherical casings, and furnished with appropriate control devices that allow to manipulate the direction and the amount of the magnetic output (and thus also the magnetic thrust force). Such individual propelling modules of the Magnocraft, which include a twin-chamber capsule (or a spider configuration), together with the control devices and with the spherical casing that hosts them, are called "**magnetic propulsors**".

LC1.3. Magnocraft of the first generation and modifications of it

Before we begin the presentation of next topics of this monograph, their deductions become much clearer if at this stage we explain briefly to ourselves the design and operation of this extraordinary Magnocraft. After all, later this Magnocraft, like a mythological "thread of Ariadna", become the source of everything that is described in this monograph. Thus it directly led to the eventuation of this monograph. The "Cyclic Principle" and the resultant "Periodic Table of Propulsion Systems" that I discovered and briefly introduced before in subsection LC1.1, indicates that there will be many generations, kinds, and types of Magnocraft completed on Earth - similarly as presently many different types of aeroplanes are build. Each one of them will be called differently. Also each one of them will have slightly different attributes. All of them are more exactly named and presented in subsections B1 and LC6. But at the very beginning, the simplest one of them will be build. In this monograph this simplest one is called the "discoidal Magnocraft of the first generation" or just the "Magnocraft". For a better understanding of next topics, let us now learn in brief basics of this extraordinary space vehicle.

The appearance of a discoidal Magnocraft of the first generation, presented in a side view, is shown in part (b) of **Figure C1** from volume 2 of this monograph, and also in all Figures from chapter G in volume 3. In turn, the general design of this vehicle is illustrated in part (a) of the same Figure C1. The external shape of this vehicle resembles a disk, or an inverted saucer. This is why it is called a "discoidal Magnocraft". Its propulsion system is composed of the devices called "Oscillatory Chambers" (in Figure C1 these oscillatory chambers are illustrated in part (c) as transparent cubes assembled inside of spherical casings).

The basic design of discoidal Magnocraft described above can then be modified to obtain other propelling devices and vehicles. Two most useful out of such modifications are "personal propulsion" and "four-propulsor Magnocraft". The detailed description of their designs, principles of operation, and attributes, together with appropriate illustrations, is provided in chapters D and E of this monograph, and in chapters H and I of monographs [2e] and [1e]. **Personal propulsion** system is a kind of Magnocraft that is build into a form of suit that is wear by the user. In this suit two miniaturised main propulsors are assembled into soles of shoes, while eight miniaturised side propulsors are assembled in a special eight-segment belt. The propelling system received in this manner allows the user to fly in the air, to walk on water or on ceiling, or to jump on huge heights or lengths without the use of any visible vehicle. **Four-propulsor Magnocraft** is received through attaching appropriate propulsors to four corners of a portable cabin. The propulsors of this vehicle use "spider configurations" of oscillatory chambers. As this was explained before, such spider configurations are simple

combinations of oscillatory chambers, that work as alternatives to twin-chamber capsules. In them, a single central oscillatory chamber is surrounded with four side chambers. Thus, the resultant configuration slightly resembles a barrel, while its operation imitates a miniature Magnocraft that has no crew cabin. When four such spider configurations are propelling a portable cabin attached to them, the effect resembles a "log cabin" that is lifted by corners with four miniature Magnocraft. The famous UFO abduction of the late Jan Wolski of Poland, that is described in chapter Q of this monograph, and in chapter O of monograph [1e], was carried out by such four-propulsor UFO.

* * *

As I am going to explain this step-by-step in subsection W4, the development and publishing the design and operation of the Magnocraft that I described above, gave me to the hand an end from the extremely long rope, or from the mythological "Ariadna thread", which later gradually led me to countless further discoveries and inventions. These in turn, in the final effect eventuated in the writing of this monograph. Thus the Magnocraft turned out to be a source of inexhaustible and constant inspiration that motivated my actions throughout the rest of my life.

LC1.4. Magnocrafts second and third generations and their operational capabilities

Right after the Magnocraft two most advanced flying vehicles that are predicted by the "Cyclic Principle" can be build. These vehicles will represent just slightly more advanced versions of the Magnocraft described in chapter G and briefly summarized above in subsection LC1.3. Only that, according to this Cyclic Principle, their propulsion systems will be able to generate these two additional phenomena, i.e. technically induced telekinesis, and changes in the elapse of time. For this reason these two vehicles are called Magnocraft of the second and third generations. So, together with the Magnocraft of the first generation described in chapter G, our civilization is going to build three generations of this vehicle, in each subsequent generation utilizing increasingly more complex attributes of magnetic fields. Let us now outline briefly the characteristics of these vehicles.

- **The Magnocraft of the first generation** - described briefly in subsection LC1.3. Amongst all three advanced flying vehicles, firstly on our planet will be build the „Magnocraft of the first generation”, called also "discoidal Magnocraft" or simply "Magnocraft". For purposes of propelling it is going to use just only the repulsive and attractive interactions of magnetic fields. These interactions represent the equivalent of mechanical force interactions utilized in the car's wheel, or the buoyancy of gases utilized in operation of balloons.

Describing the Magnocraft of the first generation with the use of technical terminology from subsection B5, this vehicle can fly in just one convention, namely in the magnetic convention.

-**Magnocraft of the second generation** (telekinetic vehicle) - described in subsection LC2. After the Magnocraft of the first generation will be build the Magnocraft of the second generation, called here also the telekinetic vehicle. The Magnocraft of the second generation was not discussed yet in this monograph, so for the description of it the rest of this chapter M is devoted, while examples of the use of it are provided in chapter T. In flights it will be utilizing additionally the magnetic equivalent of inertia, means the phenomenon called telekinesis which manifests itself in the manner as this would be done by the reversal of friction. Because the Concept of Dipolar Gravity states that on just such magnetic inertia is based the so-called „Telekinetic Effect", thus the Magnocraft of the second generation will fly utilizing exactly the same principle which causes the telekinetic motion. In this way the operation of it becomes similar to other known propulsion systems, the principles of which were based on the utilization of inertia, e.g. to hovercraft or to the aircraft propeller.

Describing the Magnocraft of the second generation with the use of technical terminology from subsection #B5, these vehicles can fly in two different conventions, namely in the magnetic and telekinetic conventions. In the magnetic convention their propulsors

generate only the phenomena of magnetic attraction and repulsion. Thus in the sense of principles of operation they use for flights, they become almost identical to the Magnocraft of the first generation described in chapter G. Also all other phenomena that they then induce will be identical to these induced by Magnocrafts of the first generation. In turn in the telekinetic conventions their propulsors generate additionally the phenomenon of technical telekinesis. Thus then they fly in the result of the Telekinetic Effect action. After this convention of flight is switch on, these vehicles and their crews are getting into the state which this monograph calls the „state of telekinetic flickering”. The material objects subjected to this state switch on (flicker) very fast between two forms of existence, i.e. material form and the form of energy pattern (more comprehensively this is explained in subsection LC3). It is this telekinetic flickering that allows these vehicles to become completely invisible to human sight and cameras, and also allows them to penetrate through solid objects as if these solid objects are made of an easily penetrable liquid instead of a stiff matter.

-Magnocraft of the third generation (time vehicle) – described in chapter M from the next volume 11. At the end, the Magnocraft of the third generation is to be build on Earth, here called also the “time vehicle”. This one was also not discussed yet, thus to the presentation of it devoted is a whole separate chapter M. In turn examples of the use of it are presented in chapter T. The Magnocraft of the third generation will utilize three attributes of magnetic fields, i.e. forces of magnetic interactions, inertia, and internal energy. Because the mastery of internal energy of magnetic fields allows for the manipulation on time, the Magnocraft of the third generation will have the ability to travel in time.

Describing the Magnocraft of the third generation with the use of technical terminology from subsection B5, these vehicles can fly in three different conventions, namely in the magnetic and telekinetic conventions, and additionally also in the convention of time vehicles. So independently of the ability to fly in the magnetic and telekinetic conventions, they are also able to fly in the convention of time. In this convention their propulsors generate changes in the speed of the elapse of time or phenomena of shifting someone to another point in time. For example, they will be able to shift time back, change time to any selected point in past or future, slow time down or accelerate it, etc. Time vehicles will generate a whole range of unique phenomena related to time, the most important of which are discussed in subsection M4.

At this point it should be emphasized, that for a person unfamiliar with appropriate theoretical foundations, the appearance of Telekinetic Vehicles and Time Vehicles will be identical to the appearance of an ordinary Magnocraft. Therefore such a person will not be able to distinguish between these vehicles of different generations, and thus also to prepare himself or herself to a type of phenomena that he or she may face in their presence. All three generations of these vehicles will have exactly the same shapes, dimensions, range of types, and will also be constructed from materials displaying the same visual characteristics. For the duration of flights all these vehicles will also couple into the same flying arrangements - see Figure G6. Furthermore, their mutual similarity will be reinforced additionally by the fact that the Magnocraft of the second and third generation will be able to switch their operation onto the magnetic convention thus displaying the same range of phenomena that an ordinary Magnocraft does. The differences existing between them become apparent only when they switch on their most advanced convention of flight, inducing in that way the phenomena characteristic for just the second or the third generation of magnetic propulsion systems. For an expert this difference will become also visible from some technical details (e.g. from the shape of their Oscillatory Chambers - see subsection F3).

LC1.5. Significance of the Concept of Dipolar Gravity as a theory which explains the operation and capabilities of Magnocrafts of the second and third generations

In 1985 I was granted the privilege of developing an extraordinary scientific theory called the "Concept of Dipolar Gravity". Although instead of being accepted and considered

by official Earth's science, so-far this scientific theory is mainly criticized and attacked by many "grey personalities" which act from hiding, in fact in real life it turns out to be extremely useful. For example, it explains exactly how telekinesis work, how to trigger telekinesis in a technical manner, and also explains what is this "Telekinetic Effect" that allows us to build, amongst others, the Magno-craft of the Second Generation called also the "Telekinetic Vehicle".

Although this Concept of Dipolar Gravity is comprehensively explained in volumes 4 and 5 of this series of monographs, in case the reader has no access to these volumes, and also to briefly remind these parts of the Concept of Dipolar Gravity which are required to understand the explanations that follow, herewith I am summarizing the essence of it.

The fundamental scientific discovery on which the theory called the Concept of Dipolar Gravity was based, was the finding that gravitational field in fact displays the presence of all attributes of a so-called "dynamic dipolar field". This means, that the beginning of this theory stems from the discovery, that the gravitational field does NOT at all belong to a static monopolar type of field - to which our official science categorized it to-date, but is just such a dynamic dipolar field. In turn this (one would think) small error of the science to-date in qualifying the gravity field into a wrong category, introduces a huge consequences to our understanding of the operation of the universe. If gravity field has a dipolar character, means if it has two poles "In" and "Out" - similar to poles "N" and "S" from magnetic fields, then the gravity pole "In" which we see around us, is just only one of poles of this field. Another pole "Out" of gravity field must hide somewhere from us. Because gravity has a concentric character, this practically means, that the other pole "Out" of dipolar gravity must penetrate into another world and emerge over there in a manner that is unnoticeable to our physical senses. Thus, the first and the most important consequence of dipolar gravity is, that according to it our universe must be composed of two parallel worlds, i.e. "our world" in which we live, and a parallel "**counter-world**" to which our physical senses have no access. Also, as it can be proven, the requirement of mutual balancing of gravity forces, causes one more shocking consequence. Namely, in such a dipolar gravity every object formed from matter in our world, must have in the counter-world an exact duplicate formed from "counter-matter". Expressing this in other words, according to the Concept of Dipolar Gravity, each one of us who lives in our world, must have its "phantom" which lives in the counter-world. According to this concept, such "phantoms", means such exact counter-material duplicates, must also exist for all other objects, including trees, rocks, cars, computers, etc.

The Concept of Dipolar Gravity states also, that such a "phantom" of any physical object can be independently caught and moved in another place. But because this counter-material duplicate is bind by gravity forces with a given physical object that exists in our world, if we relocate in the counter-world this "phantom", then the physical object also becomes moved in our world. Such a manner of relocating objects, in which grabbed and moved is the "phantom" of these objects, while objects themselves must follow these "phantoms" pulled by gravity forces, is known on Earth under the name of "**telekinesis**". The Concept of Dipolar Gravity explains also, that telekinesis can be released in a technical manner. This technical version of telekinesis is triggered when the "phantom" of a given object is "wrapped" in force lines of magnetic field, and then these force lines are accelerated.

The findings of the Concept of Dipolar Gravity, which inform us how to trigger technically the "Telekinetic Effect", have also this advantage, that they define exactly what actually this effect is. So let us now provide this definition, taken from subsection H6.1.2 in volume 4 of this series of monographs. Here it is: "**The Telekinetic Effect is a phenomenon of the indirect manipulation of a physical object obtained via the interaction with the counter-material duplicate of this object.**" This definition explains that the Telekinetic Effect is, amongst others, the source of telekinetic motion in a manner similar as the physical force is a source of physical motion. But there is a whole range of differences between the physical force and the Telekinetic Effect (this is why, in the explanations which follow, I avoid using the term "force" for naming the motion-creating product of the Telekinetic Effect, and rather name it with the term "telekinetic thrust"). The most important of these differences is that **(1) the**

Telekinetic Effect does NOT exert (return) a reaction force to its cause. (For a physical force, every action force must produce an equivalent reaction force to be returned to (exerted upon) the object causing this action). Practically this means that the increase in work completed by the Telekinetic Effect does not involve any change in the amount of energy required for the release of this effect. Moreover, the support of such telekinetic devices does not require any force, no matter what weight they lift. This suggests that a device that releases this effect can also be suspended in space, and that the lack of reaction forces allows it to remain unaffected independently of the scale of action that it causes. Also, for example, a portable telekinetic crane lifting any object (e.g. a building, or a huge rock) can be held in a child's hand without any effort. Furthermore, this implies that the Telekinetic Effect allows actions which are physically impossible for forces, such as someone lifting himself up into the air (as we know, in physical motions this is completely impossible, thus originates the anecdotic saying about "someone lifting himself by pulling upwards his own hair"). An example of telekinetic self-lifting is "**levitation**" means self-induced ascend. The other major difference between the Telekinetic Effect and a physical force, is that **(2) the Principle of Energy Conservation is satisfied for the Telekinetic Effect due to a spontaneous extraction of thermal energy from the environment by a telekinetically moved object itself.** This in turn means, that the energy required for carrying out the telekinetic motion always supply the receivers, not the givers, of this motion. Therefore the completion of a telekinetic work does not require any external energy supply. So the fulfilment of the Energy Conservation Principle by receivers (not by the donors) of the telekinetic motion is accomplished due to the cooling down the environment of given objects during the process of telekinetic motion. This in turn leads to a number of phenomena explained later, such as the rapid cooling down the environment of objects shifted telekinetically, the emission of a subtle "extraction glow", etc.

The knowledge of the Telekinetic Effect and principles of triggering it in a technical manner allows us to work out the design and operation of Magnocrafts of the Second Generation also called "telekinetic vehicles". The subsections that follow are to explain this design and operation.

LC2. Operation and attributes of the Magnocrafts of the second generation called also "telekinetic vehicles"

We should expect the first Telekinetic Vehicle to be built around the year 2200, when the Magnocraft's magnetic propulsors will be supplied with the additional capability of producing the Telekinetic Effect. According to the omnibus trend discussed in subsection B3, this vehicle will be developed as a more advanced modification of the ordinary Magnocraft, capable of operating in either the magnetic or telekinetic convention. This explains the other name for the Telekinetic Vehicle, which is the Magnocraft of the second generation.

The operation of the Magnocraft of the second generation will be based on the utilization of the Telekinetic Effect already discussed in subsection H6.1. An explanation of this operation should be started from reminding that propulsors of every Magnocraft produce pulsating magnetic field. Of course, the very nature of pulsations is such that the magnetic field which is subjected to them, during subsequent variations in time must undergo through sequences of accelerations and decelerations. Therefore in every Magnocraft pulsations of the field must create some telekinetic pull. Unfortunately in the Magnocraft of the first generation this pull is too small and wrongly directed in order to produce any meaningful propelling thrust. But if these accelerations and decelerations of the Magnocraft's field are appropriately controlled then they are able to provide the significant telekinetic thrust to the vehicle contained in their range. Of course, in order to achieve such sophisticated control over the "variation in time" of the field produced by the Magnocraft's propulsors, a new generation of Oscillatory Chambers must be build. These new (octagonal) chambers of the second generation will have eight side walls (i.e. twice as many as in the square chambers of the first

generation). For this reason, the Magnocraft of the second generation will be easily identifiable by its octagonal Oscillatory Chambers of the second generation, which it employs in all its propulsors.

Depending on the polar orientation in relation to the environmental magnetic field (i.e. in relation to the field of Earth, Sun, or Galaxy), the propulsors of every Magnocraft can be subdivided into two categories - see Figure LC1 "a". The first of them (M) is oriented as to repel the environmental magnetic field, whereas the second one (U) - as to attract. The propulsors oriented as to attract the environmental magnetic field in chapter F were called "stabilizing propulsors". From the magnetism it is known that every two sources of magnetic fields which mutually attract each other must create common magnetic circuits. In these circuits the same force lines of magnetic field will loop through both sources (see Figure L6). Therefore also a significant part of the force lines of magnetic field created by the stabilizing propulsors of the Magnocraft must be simply an extension of force lines of the environmental (Earth's) magnetic field. This in turn means that the flying Magnocraft is "wrapped" into the environmental magnetic field, the force lines of which pass through the propulsors of this vehicle. Thus, if the curves of variations in time of the pulsating field produced by the propulsors of the Magnocraft are appropriately controlled, this must also control the pulsations of the environmental field in which a given Magnocraft is "wrapped". The controlled pulsations of the environmental field will create vectors of acceleration and deceleration of this field directed at the shell of the vehicle. In turn these vectors will create the Telekinetic Effect the pull of which will produce the thrust force propelling the vehicle into a desired direction.

The mechanism for producing the telekinetic pull described above realizes that in the Magnocraft of the second generation the propelling thrust is formed by the forced pulsations of the environmental magnetic field (i.e. the field of Earth, Sun, or Galaxy) not by the field of a given vehicle. The field of the vehicle's propulsors is only used as the agent which makes the environmental field to wrap around the vehicle and to pulsate, not as the creator of the propelling forces. This in turn introduces a number of very important consequences to the magnetic field produced by the Telekinetic Vehicles. The most important of these consequences is that the mean density of the field produced by the propulsors of Telekinetic Vehicles does not need to differ from the density of the environmental magnetic field. Therefore, for our present research instruments the magnetic field of such vehicles can be absolutely undetectable. Practically speaking this means that at our present (relatively low) level of advancement we may not have any instruments capable of informing us about the existence of such vehicles in our close proximity.

The same number of technical versions of the Telekinetic Vehicle can be built as these of the ordinary Magnocraft. Therefore, except for the disk-shaped flying vessel (refer to the disk-shaped Magnocraft described in chapter F), the Telekinetic Vehicle can also be produced as a Telekinetic Four-Propulsor Spacecraft (refer to chapter D), and Telekinetic Personal Propulsion (refer to chapter E). In each of these technical versions, the Telekinetic Vehicle will keep all its major characteristics, which are summarized at the end of this subsection.

At this point it should be mentioned that the effect of operation of the telekinetic propulsors will not affect people's health as much as the use of magnetic propulsors will. (An exactly opposite phenomenon will occur - as the carrier of the Telekinetic Effect the magnetic field of these propulsors will stimulate the improvement of health of all organisms from the vicinity.) For this reason the future users of Telekinetic Personal Propulsion will not need to wear the protective garments that are necessary features of magnetic personal propulsion (see Figures I2 and I4). On the other hand, in the age of telekinetic propulsion systems, the process of miniaturization will be more advanced when compared with that of magnetic personal propulsion. Both the above factors together, i.e. no detrimental health effects and advanced miniaturization, will make it possible for the elements of Telekinetic Personal Propulsion to be inserted surgically into the bodies of people, instead of being carried as additional equipment. Such a surgical insertion will ensure that they will not forget to take this propulsion with them wherever they go, making it always available whenever needed. As the capabilities of Telekinetic Personal Propulsion are extraordinary (refer to the last paragraph in

this subsection), having it ready for use in any situation could save numerous lives and prevent countless tragedies. For example, the majority of accidents would be avoided if victims could have telekinetic propulsors built into their bodies. In addition to this purpose, the Telekinetic Personal Propulsion will provide its users with numerous everyday advantages. To give some idea as to what could be achieved with such a built-in body propulsion system, it is sufficient to view the television series "The Magic of David Copperfield" (CB, Director: Stan Harris). All the extraordinary achievements that the magician David Copperfield demonstrates, such as walking through walls, passing through iron gates, surviving the impact of deadly objects, flying in the air (through the Great Canyon), etc., in the future can be part of the everyday activities of ordinary people equipped with Telekinetic Personal Propulsion System.

The low density of the magnetic field produced by the Magnocraft of the second generation, combined with the capability of the telekinetic component of this field to stimulate biologically the soil, cause that the landing sites of the Magnocraft of the second (and also the third) generation will differ from the landings of the Magnocraft of the first generation. The main of these differences will depend on the fact that the Magnocraft of the second (and also the third) generation which landed in their most advanced convention of flight will usually not cause any scorching nor biological sterilization of the soil. Contrary, in areas where this soil was exposed into the action of their magnetic field, it becomes stimulated biologically. In the effect of this stimulation all the vegetation (and also other living organisms) growing in the area saturated with the telekinetic field of a given vehicle rapidly experience an explosive increase of the intensity and speed of the growth. Furthermore, the healing attributes of the telekinetic field frozen in this soil will attract ill animals from the vicinity which will display the instinctive tendency to improve their health by lying on such telekinetic landing sites. Finally the soil of such landing sites may display a different proportion of elements than the surrounding soil (e.g. the content of calcium may increase even up to seven times - see subsection LB2). All the above phenomena will appear in the effect of stimulants explained in subsection LB2. The biological stimulation of the landing sites of these vehicles may cause even up to twelve times faster and more intensive growth of vegetation in relation to the surrounding soil. Because of the increased health of this vegetation also its colour become more vivid (healthy) than the colour of the surrounding vegetation of the same type. Because of all this, the landing sites of the Magnocraft of the second (and also the third) generation can be identified as rings on the soil where vegetation grow faster and more intensively than the vegetation from the surrounding area, and also where the colour of this vegetation is slightly different. The shape of these rings will closely resemble the shape of scorched areas left after landings of the Magnocraft of the first generation. Of course, as time elapses also the biological stimulation of the soil in former landing sites of the Magnocraft of the second generation will gradually diminish according to the (radioactive) curve of "half-life".

Although the properties of the Telekinetic Vehicle do not correspond to those of any other device already known on Earth, the characteristics of this future spacecraft can be deduced from the Concept of Dipolar Gravity. I have completed this process of deduction, and the conclusions that I derived are summarized below. As the limited space in this monograph allows only for the more important ideas to be elaborated in detail, readers are welcome to contact me about any specific inquiry they may have regarding matters which are discussed.

LC3. The state of telekinetic flickering and the consequences of it

The vehicles and devices propelled by telekinetic propulsors, are going to induce during their flight a whole range of phenomena, which are unique for attributes of the counter-world and counter-matter, but which remain unknown to the orthodox science, because they do not appear in the physical world. For the majority of these phenomena the Concept of Dipolar Gravity already at the present level of its development is able to forecast their course and final effects. In this subsection descriptions are provided, which present several most important out of these phenomena.

The key to our understanding of the extraordinary properties of telekinetic vehicles and propulsion systems, is to understand the unique state of matter subjected to telekinetic motion. This state is called here a "**telekinetic state**". The telekinetic state of a material object (e.g. a vehicle or a person) is a reversal of the physical state of that object. It appears only for the short duration of the telekinetic motion. Generally speaking this state is caused by the unique mechanism of the telekinetic motion (or strictly: by the way in which counter-material components pull their material duplicates during a telekinetic motion - see the description of this motion provided in subsection H6.1). Thus, every telekinetically moved object remains in the physical state before and after this motion occurs, and is transformed into the telekinetic state for the exact duration of the telekinetic motion. After applying the above to telekinetic vehicles, the telekinetic state appears while these vehicles operate in the telekinetic mode, and ceases to exist when these vehicles operate their propulsors in a magnetic mode of operation. Of course, this state also appears during biological telekinesis, although its attributes are not so obvious. For example, one of its manifestations is an unexplained previously transparency of solid objects, recorded on some photographs of objects moved in a psychokinetic manner. Such a transparency is visible at good quality reproductions of photograph from Figure H2, that show tables lifted up psychokinetically by an English medium named Eusapia Palladino (these photographs were published in Journal [1FigH2] "The Unexplained", Vol. 4, Issue 41, page 801 - see also Figure D7 in [1a]).

The material component of each object that is subjected to the telekinetic state (e.g. a UFO-naut, a UFO vehicle, a levitated person, a rotor in the telekinetic motor, an object shifted in the effect of human psychokinesis, etc.), undergoes the following three transformations:

(1) **Decomposition** from a material (hardware) form into a non-material (software) one. The non-material (software) form can be explained as a kind of energy pattern, which is entirely stripped of physical attributes such as mass, density, inertia, optical properties, and so on. It is characterised by the fact, that objects in this state are completely transparent and weightless, as if they are formed from "vacuum" or energy, although they maintain their original shape and dimensions.

(2) The **shift** to a new location, determined by a telekinetic motion that the object is subjected to. During this shift the material part of this object exists only in its non-material (software) form, as an energy pattern.

(3) **Recomposition** back into the original, material form. After this recomposition is completed, the material component of the object begins to exist again in its physical (hardware) form. All its properties return to exactly the same state as they were before the telekinetic transformations began.

It should be stressed here that the transformations occurring within the telekinetic state do not change the level of energy accumulated in a given object. Thus, according to what was written in subsection H6.1, any work completed in this state, must be accompanied by the absorption of thermal energy from the environment combined with the emission of the extraction glow.

The three transformations described above are the cause of the extraordinary properties of objects which entered into the telekinetic state. Such objects lose most of the attributes and limitations characteristic of the physical state of matter, and simultaneously gain another set of attributes, which are more characteristic of some non-material forms, such as algorithms, designs, information, clusters of energy, fragments of vacuum, etc. The new properties of objects turned into the telekinetic state are as follow:

(a) The ability to penetrate through other material objects without disturbing or damaging in any way the structure or consistency of either objects.

(b) The ability to be penetrated by other material objects without causing any damage to either of these objects.

(c) The loss of basic physical properties, such as inertia, density, weight, external friction, etc.

(d) The non-absorption and non-reflection of light, thus becoming totally transparent.

(e) The exchanging of thermal energy with the environment. The amount of exchanged energy is an exact equivalent of the energy consumption (or yield) necessary for the sustaining of the telekinetic motion (see subsection H6.1).

(f) The emission of a white "extraction glow", or a white glow with a green tinge called here the "dispersion glow". The intensity of this emission is proportional to the consumption (or production) of thermal energy caused by a given work done telekinetically. The area of the emission exactly reflects the object's outlines.

(g) The obtaining of an attribute of indestructibility, and temporary freezing of the dimensions and parameters (unchangeability).

It should be stressed that all the above properties will be displayed only by these telekinetic vehicles, which at a given moment of time operate in the telekinetic convention (such vehicles may also operate in a purely magnetic convention, which does not show these attributes).

Three basic transformations that constitute the telekinetic state (i.e. decomposition, shift, recomposition) are completed during extremely short pulses. Each such pulse probably requires only three separate execution commands issued by the software model of a telekinetically moved object. From the interpretation of time in the Concept of Dipolar Gravity (refer to section and N1.4) we know that a single execution command constitutes an elementary unit of time for the object subjected to this command. Therefore a single pulse of the telekinetic state will extend only for an extremely short period of time, too small to even be registered by our instruments, but sufficiently long for light to propagate through the space previously occupied by a given physical object.

The complex manoeuvres of telekinetic vehicles can not always be achieved in one single pulse of the telekinetic state. For this reason the telekinetic propulsors maintain the cyclical repetition of such individual pulses, in this way extending the telekinetic state for any required length of time. There are two ways of repeating the single pulses of the telekinetic state, i.e. progressive and oscillative. The **progressive** manner depends on subjecting the propelled object into a series of telekinetic shifts having controlled ranges. This manner is used when a telekinetic vehicle is required to fly with a predefined speed along a specific trajectory. The **oscillative** manner depends on the repetitive shifting (oscillating) of the propelled object between two extremely close destinations. This manner is used when a telekinetic vehicle is required to hover, suspended motionlessly above a single area. The long periods of the telekinetic state, achieved due to the cyclical repetition of such single pulses, are called here the "sustained telekinetic state" or the "**state of telekinetic flickering**".

A characteristic feature of the **sustained telekinetic state** is that a material object (e.g. a vehicle) subjected to it appears alternately in two opposite states, i.e. telekinetic and physical. The telekinetic state takes place while single pulses are executed, whereas the physical state exists for the length of time elapsing between consecutive pulses. Depending on the frequency with which the elementary pulses are repeated, the duration of the physical state may differ. Because in both these states the optical properties of the object are opposite (i.e. in the telekinetic state the object is completely transparent and thus invisible, whereas in the physical state it is clearly visible) the visual appearance of an object subjected to the sustained telekinetic state is continually changeable from complete visibility, through all grades of partial transparency, into full invisibility. The ratio of invisibility is regulated by the frequency in which individual pulses of the state of telekinetic flickering are repeated. For example, to become completely invisible to human eyes, telekinetic vehicles need to twinkle into the physical state with the frequency exceeding that for the changes of individual frames in motion pictures (i.e. over 24 cycles per second). From measurements of frequency with which telekinetic UFO vehicles are flickering, we know that actual frequency used by such large vehicles amounts to around 2500 Hz - see descriptions of method of determining the frequency with which telekinetic UFOs flicker, described in subsection U3.6 of this monograph, and in subsection D5.1.1 of treatise [7/2]. If these vehicles glimmer with a frequency greater than that noticeable to our eyes, we are unable to see them, although their crew can see us perfectly. The level of visibility in the sustained telekinetic state can be smoothly regulated by the frequency with

which the elementary pulses are repeated. The above realizes that the telekinetic vehicles are capable of becoming invisible in at least two different ways. The first of these is the phenomenon called the "magnetic lens", which the Magnocraft of all three generations are able to switch on. Telekinetic vehicles can shield themselves with this lens in all cases when there is a need to become invisible without switching on the telekinetic convention of flight. The second way depends on the fast "flickering" from the material state into the telekinetic one, and vice versa. This one allows telekinetic vehicles to become partially transparent (like being made of a mist) or completely invisible, and also to gradually fade away while remaining motionless.

The ability of telekinetic vehicles to flicker fast between material and non-material states, explains also the principle on which these vehicles fly through solid objects, such as walls, buildings, mountains, trees in forests, etc. Their flights through such solid objects depend on passing during subsequent pulses of flickering - when the vehicle reaches a non-material state, their atomic structure between atoms of a given obstacle, on materialising between atoms of this obstacle, on next dematerialising during a subsequent pulse and further shifting through the obstacle, on materialising again, and on carrying this process continually. (As we know from nuclear physics, atoms are mainly huge empty space, which is occupied by small in dimensions nucleus and electrons.) In this manner atoms of the vehicle, its crew, and content, flickering between two states gradually move through the atomic structure of the solid obstacle that stays on their path. People that are subjected to this process, are going to experience it as a feeling of intensive vibrations of their body during the penetration through material of the obstacle. This vibration is caused by a cyclical holding back and then releasing of this body in subsequent pulses of the change of state. In turn some objects through which such a telekinetic penetration just is taking place, which structure displays quite a low level of stiffness, and a capability to generate noise (e.g. crackling windows frames, loose metal doors, etc.) are getting into significant vibrations and produce a noticeable noise, thus making an impression to a casual observer, that they are rapidly tossed by a wind.

The ability to disappear via a fast telekinetic flickering, combined with the capability of telekinetic propulsion to fly through solid objects, provides the telekinetic vehicles with an extraordinary property. They are able to fly directly into our houses without even being noticed. In that way in some houses, apart from the furniture and usual inhabitants, sometimes a whole interstellar UFO spaceship, with its crew, equipment, research laboratories, and medical instruments, could appear - and no-one who lives there would notice the presence of this vehicle. The only sign of its activity, which most probably could only be realized by people who are made sensitive to the manifestations of the operation of these vehicles, would be a sensation of a coldness slightly greater than usually, the fact that some electronic devices unexpectedly could start to behave in a strange manner - see subsection U3.6, and panic reactions of animals, whose senses usually notice the arrival of extraterrestrials. However, if in such cases someone would decide to take a photograph, then he/she could experience a shock looking at the strange picture recorded on it (though people would tend to rationalize this picture by believing that two photos out of focus were somehow recorded on a single frame).

The ability to gradually fade away gains a special significance when applied to telekinetic personal propulsion. We can easily imagine the shock and confusion experienced by someone, knowing nothing about the telekinetic state, being confronted by an advanced alien (a UFO-naut) who uses telekinetic personal propulsion. Such an alien would be capable of floating in mid-air, penetrating a wall or ceiling, and its body would appear to be transparent giving an impression of a mist. Deadly objects (bullets, knives, swords, axes, etc.) directed at the alien would penetrate through its body without causing any damage. This situation is not so hypothetical as some sceptics would claim. Throughout the centuries a large number of people have reported close encounters with mysterious beings whose appearance matches exactly the above description (see subsection V8.1). Although names assigned to these beings have varied throughout the ages - from angels and devils though to succubies and

fairies, finishing with contemporary UFO-nauts - the basic attributes associated with them always correspond to those of telekinetic personal propulsion.

From the mechanism of the telekinetic state two other important properties of telekinetic propulsors stem, i.e. the range of a single shift and the speed of the resultant motion. The range of a single shift is the distance that an object (e.g. a vehicle or a person) is moved telekinetically during an individual pulse of the telekinetic state. Its quite good illustration is provided in Figure O1 of monograph [2e]. This range depends on the amount of magnetic power involved for the creation of a Telekinetic Effect, and also on the size of the shifted object. The more powerful a particular telekinetic propulsor, the greater the range of its single shift. The same powerful propulsors shift smaller objects to a greater range.

LC4. Landings of the telekinetic Magnocraft of the second generation

Telekinetic vehicles, similarly like Magnocraft of the first generation, after each landing also leave visible landing sites that are characteristic for them. In the sense of the geometry, such landing sites are going to look identically like landing sites of Magnocraft of the first generation. But in the sense of attributes, telekinetic vehicles leave different types of landings. This especially concerns the scale and permanency, as well as kinds of changes, that occur in the soil and vegetation. Some of attributes of these landing sites require here an additional explanation.

A low intensity of the magnetic field produced by the Magnocraft of the second generation, combined with the ability of the telekinetic component of this field to stimulate accelerated growth, cause that the landings of the Magnocraft of the second (and also third) generation visually differ from landings of the Magnocraft of the first generation. (Landings of the Magnocraft of the first generation are described in details in subsection F11 of this monograph.) The primary of these differences boils down to the fact, that Magnocraft of the second (and third) generation, which landed in their telekinetic convention of flight, usually do not cause the burning and sterilisation of the soil in the areas where this soil is exposed to the action of telekinetic field. (Note, however, that such magnetic scorching of the soil can be caused during landings of these vehicles in the magnetic convention of flight.) Quite opposite, in the areas where this soil is subjected to the action of the telekinetic field, a high biological stimulation takes place. In the effect, the entire vegetation, as well as other living organisms that are in this soil, experiences a rapid and explosive acceleration of the speed and size of growth - for details see subsection LB2. Vegetation from the soil exposed directly to the action of telekinetic field may grow up to 12 times higher and faster than the surrounding vegetation. Also it looks much healthier. Furthermore, the healing properties of the telekinetic field frozen in the soil act like a magnet to nearby animals, especially to sick ones. Such animals show an instinctive tendency to improve their health through lying on such telekinetic landings. Finally the soil of such landings may show different proportions of micro-elements than the surrounding soil. For example, it may have several times higher content of calcium. This is caused by the ability of the telekinetic field to facilitate the "cold fusion" of some elements. The above phenomena occur in the effect of action of factors described in subsection LB1.

The biological stimulation of landings of telekinetic vehicles may cause even up to 12 times increase of the speed and height of the growth of vegetation in the area exposed directly to the telekinetic field, in relationship to vegetation that grow in surrounding areas. Because of the intensified health of this vegetation, also the colour of it is more vivid (healthy looking) in relationship to the similar vegetation that grows nearby. Thus, the former landings of the Magnocraft of the second (and third) generation, can be identified as rings of the soil in which vegetation grow many times higher and have more vivid and healthy colour than the surrounding vegetation. (These rings are very similar in shape to rings scorched in the soil by the magnetic field of Magnocraft of the first generation.) As time elapses, the stimulative ability of this area is going to decrease according to the curve of half-life - see subsections LB2 and KB4.

LC5. Modifications of Magnocraft of the second generation

LC5.1. Telekinetic four-propulsor vehicle

Similarly as this is the case with Magnocraft of the first generation, which work exclusively in the magnetic convention, also Magnocraft of the second generation can be constructed in several different designs. And so, independently from discoidal vehicles described in subsection LC2, also telekinetic four-propulsor vehicles, and telekinetic personal propulsion systems are going to be build.

Telekinetic four-propulsor vehicles are shown in **Figure LC2**. They look similarly to the four-propulsor vehicles of the first generation shown in Figure D1 and described in Table D1. But there are various vital details which allow to distinguish between these two generation of vehicles. Let describe here these details briefly.

The most easy to see out of these details, is the square doorway or a porthole that exists in the floor of four-propulsor vehicles of the first generation, but do NOT exist in floors of such vehicles of the second and third generations. This doorway or porthole is visible in part (1) of Figure LC2, and also in Figure Q1. The existence of it in four-propulsor vehicles of the second and third generation becomes obsolete, because during coupling several such vehicles into flying cigars, their pyramidal roofs simply penetrate telekinetically through floors of vehicles with which they are coupled. So the porthole in the floor, which in vehicles of the first generation after being opened allows to insert into itself the tip of this pyramidal roof of another such vehicle, in the vehicles of the second and third generation becomes obsolete.

Another detail which allows to differentiate between the first and the second generation, are doors in the side wall. These doors are present in vehicles of the first generation, but are absent in vehicles of the second and third generations. After all, the telekinetic entering of decks of these vehicles, is carried out in them directly through their walls.

Another, and probably the most distinct detail, that allows the conclusive identification of vehicles of subsequent generations, are their propulsors. Although the dimensional proportions of propulsors are similar in vehicles of all three generations, their shapes, and also the appearance of their outlets, are significantly different. Four-propulsor vehicles of the second generation have propulsors, the aerodynamical casings of which take the shape similar to a flattened sphere or a "pumpkin" - see descriptions in subsection F7.2.2. In this sphere or "pumpkin" the height is slightly less than the width - see Figure F11 (2s). Sometimes they may also be shaped like a kind of gearwheel placed on an axle - as this is shown in part (2) of Figure LC2. These propulsors clearly differ from the barrel-shaped or amphora-shaped propulsors used in vehicles of the first generation, in which the height is about 1/4 larger than the width - for details see Figures C9 and D1. Furthermore, such propulsors contain spider configurations of the second generation in themselves, which are based on the octagonal oscillatory chambers. Thus the octagonal shape of their outlets, and also the number 8+1 of these outlets, are clearly different than the square outlets from propulsors in vehicles of the first generation.

A further attribute allowing for distinguishing between both generations of vehicles discussed here, are phenomena that they induce. Vehicles of the first generation induce only magnetic phenomena. Examples of these phenomena include black bars of magnetic field that leave the propulsors, or blue or red ionisation of the air that surrounds the vehicle. In turn vehicles of the second generation induce additionally telekinetic phenomena. These include the white and ghostly extraction glow, the telekinetic flickering, ability to penetrate through solid objects, etc.

The attributes of the four-propulsor telekinetic vehicles are almost identical to attributes of the discoidal telekinetic vehicles. In turn these are summarized at the end of subsection LC2.

LC5.2. Telekinetic personal propulsion

Telekinetic propulsion systems may also be constructed as personal propulsion systems. Then, the vital consequence of the use of telekinetic field in them is, that this field is non-detrimental for health of people and living organism that happen to be in the range of it. Rather opposite, since the telekinetic field is biologically active, it is stimulating the increase of health and vitality of all living organisms - for details see the final part of subsection LB2. This happens because of both, the small intensity, and also because of the high biological activity of telekinetic field produced by propulsors of telekinetic vehicles.

Because of this harmlessness, miniaturized propulsors together with control computers of such telekinetic personal propulsion systems can be **surgically inserted** in the future directly to bodies of users of these systems. In the effect, people who have installed such propulsors, are capable to fly in the air without using any vehicles visible for human eyes. During these flights, such people simultaneously produce the ghostly "extraction glow" discussed earlier. Also they are able to walk through walls and iron plates, walk on ceilings and on water, disappear from the view at any wish, and do a lot of other actions that we now would consider to be "supernatural". Because of the placement of these propulsors in the body of users, these unique capabilities are maintained even if a given user of telekinetic personal propulsion system for some reasons would be stripped of his/her suit or/and equipment. Thus, for such devices the method of incapacitating of the users described in subsection R4, would not work.

The ability to gradually fade away and to transform from material form into a form of energy pattern, becomes especially vital if it is applied to telekinetic personal propulsion systems. This is because it transforms material users of such propulsion systems into non-material form. In turn, this their non-material form may cause, that by uneducated people such users may be taken for spirits, demons, witches or wizards, various supernatural beings (e.g. devils, angels, or vampires), and in some cases even for gods - as an example see subsections P6.1 and P5. So we can easily imagine a huge surprise and confusion experienced by someone, who does not know anything about the vehicles described in this chapter and subsection, but who is rapidly confronted by an intruder who uses telekinetic personal propulsion system. Such an intruder would be able to hover in mid-air, walk through walls and furniture, while his/her body would appear to be transparent making an impression of being made of mist. The deadly objects (bullets, knives, swords, axes, etc.) thrown or shot into such an intruder would penetrate through his/her body without doing any harm.

The attributes that telekinetic personal propulsion system is to give to the users, are almost similar to attributes given by telekinetic vehicles. In turn these are summarized at the end of subsection LC2.

LC5.3. Telekinetic tractor beam

Telekinetic tractor beam originates from the possibility of the exact directing of telekinetic impulses. This directing is accomplished by passing impulses of magnetic field along a beam of powerful light. (E.g. by passing them along a laser beam.) In such a case beams of light perform the function of "magneto-ducts" for telekinetic impulses. Simultaneously these beams by themselves are also directed by the magnetic field that they carry inside. Thus force lines of this field are going to bend slightly this beam, forming it into a shape of an arch and deviating it from a straight line that normally characterizes beams of light. The Telekinetic Effect directed in this way is to make possible in the future a fast and efficient transportation (i.e. "beaming up") of people and loads between distances, through a telekinetic channel formed from light. Future utilization of this transportation method already is illustrated on various futuristic films, where such "beaming up" is frequently used. According to the action

of the telekinetic effect, there will be no reaction forces released during such transportation, that interact with the device which produces the Telekinetic Effect. This in turn enables a device of the size of a pocket torch to be held by a child and to lift huge machines, buildings, or rocks. As distance does not make any significant difference for this form of transportation, the telekinetic beam sent from satellite stations will allow us to transport into orbit any objects or people present on Earth.

The telekinetic tractor beam is described also in subsection H6.2.1.

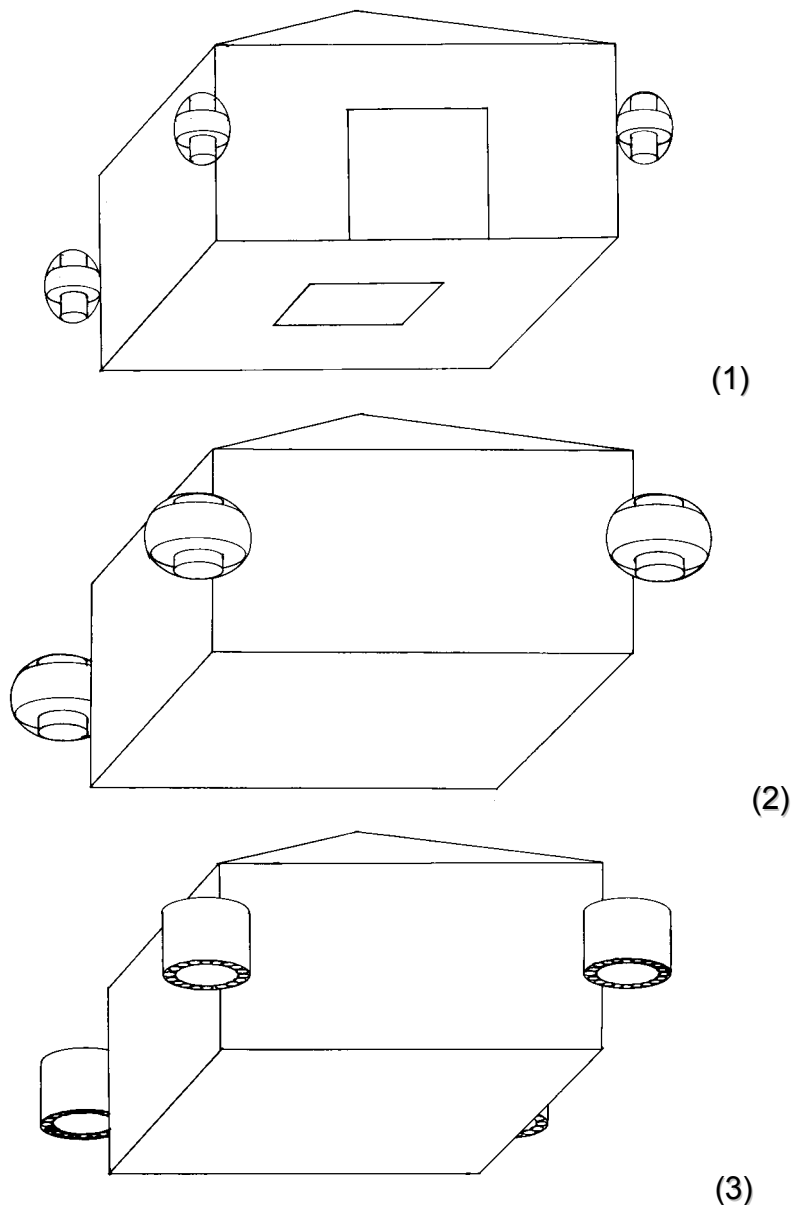

Fig. LC1. The appearance of the telekinetic four-propulsor vehicle of the second generation (shown is the type T3). This illustration is oriented towards allowing to distinguish this vehicle from similar vehicles of the first and third generation. Such vehicle most frequently takes a shape of a cubicle, on the top of which a pyramidal roof is placed. But notice that such vehicles can also be built in shapes different from cubicles, e.g. looking like rectangular huts. The mutual ratio of subsequent dimensions, e.g. the height of the entire vehicle to the height of its pyramidal roof, is defining the type of this vehicle - in this case T3. (This ratio is also illustrated in Figures D1 and N1.) The span of magnetic axis of four propulsors mounted in the mid-height of four corners of this vehicle must be identical to the span of side propulsors in the equivalent type of discoidal Magnocraft (in this case - in the type K3). Shown are:

(1) Four-propulsor vehicle of the first generation (magnetic). Propulsors of this vehicle take the shape of vertically prolonged barrel or amphora, in which the ratio of height "h" to width "g" is equal to $h/g=4/3$ (see also Figures D1 and C9). Also this is the only four-propulsor vehicle, which has square doors in the floor.

(2) Telekinetic four-propulsor vehicle of the second generation. It can be distinguished relatively easily from similar vehicles of other generations by the "pumpkin" shape of the four propulsors. In vehicles of the second generation these propulsors take a very characteristic shape of the sphere flattened vertically (or a "pumpkin") with the mutual ratio of the height "h" to width "g" equal to $h/g=2/3$ (see subsection C7.2.2 and part 2s from Figure C11). This shape results from the design conditions prevailing for spider configurations constructed from octagonal oscillatory chambers of the second generation described in subsection C7.2.2. In addition to the difference in the general appearance, the vehicle of the second generation is also going to have absolutely smooth hull, deprived of any portholes or doors. So it is NOT going to have neither a doorway shown in part (1) and in Figure D1, nor the floor doors visible in part (1) and on Figure Q1. The entering of crew, passengers, and visitors on the board of vehicle of the second generation is going to be carried out in a telekinetic manner, through the material of the walls and floors. So no doors or portholes will be needed neither in walls nor in the floor.

(3) Four-propulsor vehicle of the third generation, called also "four-propulsor time vehicle". It also does not have doors nor portholes. The propulsors of it take the striking appearance of a vertical cylinder with the ring of 16 holes around peripherals of it, looking like a "round launcher of rocket missiles" - see also Figures N1 and C11 (3s).